

Panasonic

DVCPRO HD

Camera/VTR

AJ-HDC27F E

Operating Instructions

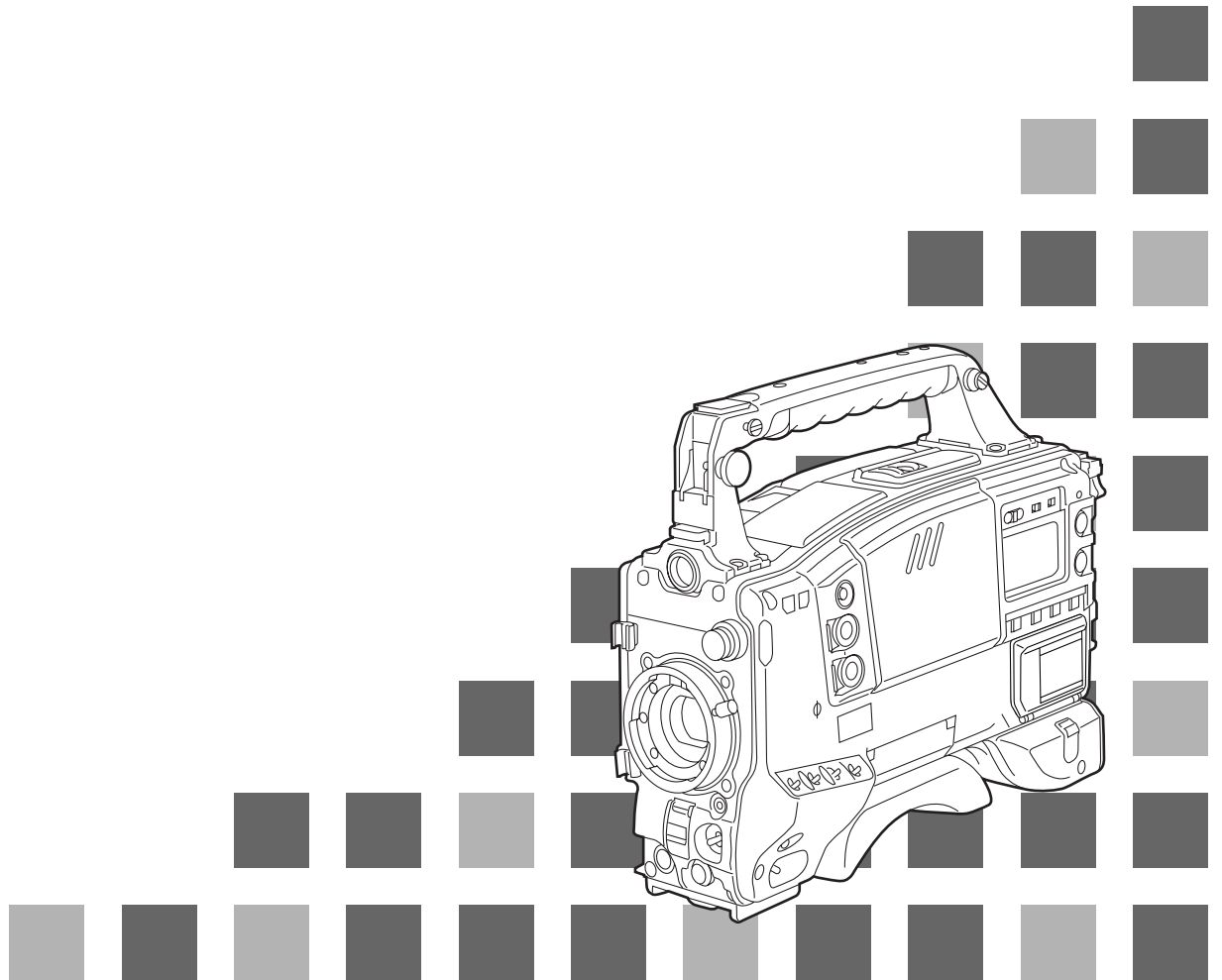

■ **DO NOT REMOVE PANEL COVER BY UNSCREWING.**

To reduce the risk of electric shock, do not remove cover. No user serviceable parts inside.

Refer servicing to qualified service personnel.

CAUTION:

TO REDUCE THE RISK OF FIRE OR SHOCK HAZARD AND ANNOYING INTERFERENCE, USE THE RECOMMENDED ACCESSORIES ONLY.

CAUTION:

TO REDUCE THE RISK OF FIRE OR SHOCK HAZARD, REFER CHANGE OF SWITCH SETTING INSIDE THE UNIT TO QUALIFIED SERVICE PERSONNEL.

WARNING:

TO REDUCE THE RISK OF FIRE OR SHOCK HAZARD, KEEP THIS EQUIPMENT AWAY FROM ALL LIQUIDS-USE AND STORE ONLY IN LOCATIONS WHICH ARE NOT EXPOSED TO THE RISK OF DRIPPING OR SPLASHING LIQUIDS, AND DO NOT PLACE ANY LIQUID CONTAINERS ON TOP OF THE EQUIPMENT.

Lithium Battery

Warning

The lithium battery in this equipment must only be replaced by qualified personnel. When necessary, contact your local Panasonic supplier.

“The lithium battery is a critical component (type number CR2032 or BR2032 manufactured by Panasonic.)

It must never be subjected to excessive heat or discharge. It must therefore only be fitted in equipment designed specifically for its use.

Replacement batteries must be of the same type and manufacturer. They must be fitted in the same manner and location as the original battery, with the correct polarity connections observed.

Do not attempt to re-charge the old battery or use it for any other purpose. It should be disposed of in waste products destined for burial rather than incineration.”

CAUTION

Danger of explosion if battery is incorrectly replaced.

Replace only with the same or equivalent type recommended by the equipment manufacturer. Discard used batteries according to manufacturer's instructions.

VARNING

Explosionsfara vid felaktigt batteribyte. Använd samma batterityp eller en ekvivalent typ som rekommenderas av apparattillverkaren. Kassera använt batteri enligt fabrikantens instruktion.

ADVARSEL!

Eksplussionsfare ved fejlagtig håndtering. Udskiftning må kun ske med batteri af samme fabrikat og type. Levér det brugte batteri tilbage til leverandøren.

VAROITUS

Paristo voi räjähtää, jos se on virheellisesti asennettu.

Vaihda paristo ainoastaan laitevalmistajan suosittelemaan tyyppiin. Hävitä käytetty paristo valmistajan ohjeiden mukaisesti.

 indicates safety information.

Attention/Attentie

- Batteries are used for the main power source and memory back-up in the product.
At the end of their useful life, you should not throw them away.
Instead, hand them in as small chemical waste.
- Voor de primaire voeding en het reservegeheugen van het apparaat wordt gebruikgemaakt van een batterij.
Wanneer de batterij is uitgeput, mag u deze niet gewoon weggooien, maar dient u deze als klein chemisch afval weg te doen.

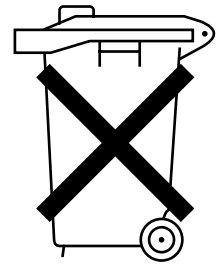

To remove the battery/Verwijderen van de batterij

Main Power Battery (Ni-Cd Battery)

Batterij Voor Primaire Voeding (Nikkelcadmiumbatterij)

Battery/Batterij AU-BP402

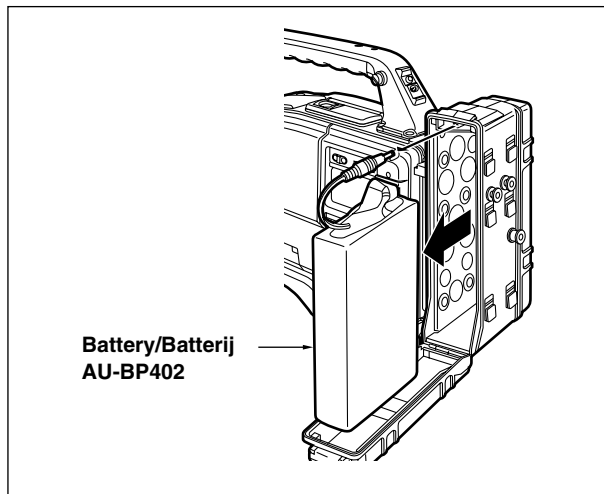

Anton/Bauer Battery

Anton/Bauer-Batterij

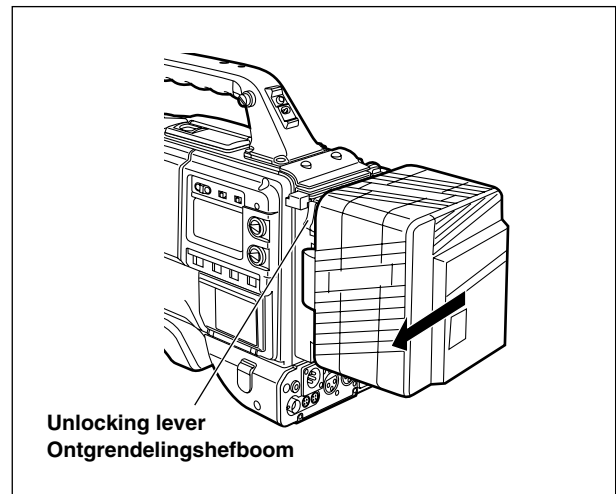

- If a battery made by any other manufacturer is to be used, check the Operating Instructions accompanying the battery.
- In geval u een batterij van een anden fabrikant zou gebruiken, gelieve dan eerst zorgvuldig de gebruiksaanwijzing van deze batterij te lezen.

Back-up Battery (Lithium Battery)

Batterij Voor Reservegeheugen (Lithiumbatterij)

- For the removal of the battery for disposal at the end of its service life, please consult your dealer.
- Raadpleeg uw leverancier over de verwijdering van de batterij op het moment dat u het apparaat bij einde levensduur afdankt.

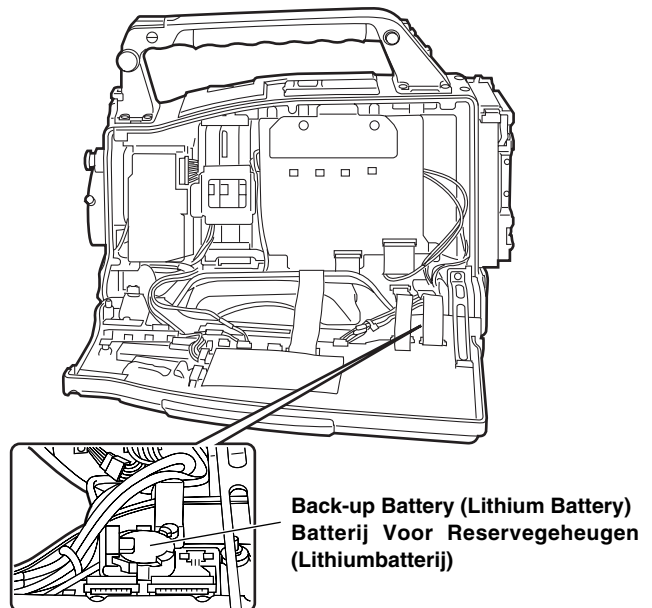

Contents

Introduction	6	Screen displays	51
Features	6	Remaining battery charge and audio channel level and remaining tape displays	51
Features of the camera unit	6	Displays relating to errors and warnings	51
Features of the VTR unit	8	Displays relating to time codes	51
System configuration	9	Adjusting the date and time	52
Parts and their functions	10	Adjustments and setup using the setting menus	52
Power supply section	10	Adjusting the white balance and black balance	53
Accessory mounting section	11	Adjusting the white balance	53
Audio function section	12	Adjusting the black balance	57
Viewfinder section	14	Setting the electronic shutter	58
Shooting (recording)/playback function section ..	15	Shutter modes	58
Warning/status display section	20	Registering the shutter speed	58
Menu operation section	21	Setting the shutter mode and speed	59
Time code related section	21	Changing the shutter speed and mode selection range	59
Power supply	23	Setting the synchro scan mode	60
Using the Anton/Bauer battery pack	23	Switching the shutter speed display	60
Using the BP-90 type battery pack	24	Film tone gamma function	61
Using the Sony NP-1/BP-90 battery pack	25	Switching the frame frequency	61
Using the V-mount type battery pack	25	Variable frame rate	62
Using an AC power supply	26	Setting the frame rate	62
when the AJ-B75 AC adapter is used	26	Scan reverse	64
when the AJ-B75 AC adapter is used	26	Setting the scan reverse	64
Attaching the lens	27	Adjusting the audio level	64
Adjusting the lens flange	28	Manual audio level adjustments	64
Adjusting the white shading	29	Limiter	64
Adjusting the viewfinder	33	Setting the time data	65
Attaching the viewfinder	33	Setting the user's bit	65
Detaching the viewfinder	33	Setting the time code	66
Adjusting the viewfinder position	34	Externally locking the time code	67
Audio input preparation	35	Tape management information	68
When attaching a microphone to the viewfinder (optional accessory) for use	35	How to use the user data	69
When attaching a microphone to the main unit for use	36	How to use the scene file	70
When connecting a microphone to the MIC IN jack	37	Setup card operations	74
When connecting a microphone to the AUDIO IN connector	37	Formatting the setup card	75
When using a wireless microphone	38	Saving the data settings on the card	76
When connecting audio components	38	Loading the data saved on the card	78
Mounting the unit on a tripod	39	Cassette tapes	80
Attaching the shoulder strap	40	Recording	81
Adjusting the shoulder pad position	40	Shooting	82
Attaching the rain cover	41	Scene-to-scene continuity	83
Connecting the extension control unit	41	Playback (checking what has been recorded)	84
Viewfinder lamp displays	42	Rec review	84
Setting the Ⓛ lamp displays	43	Colour playback	84
Viewfinder screen status displays	44	Lens RET button functions	84
Selecting the display items	46	Other VTR functions	85
Display modes and setting change messages ..	48	NEWS REC function	85
Switching the display mode	49	RETAKE function	85
Setting the marker displays	49	INTERVAL REC (intermittent recording) function	85
Setting the camera ID	50		

Contents

Menu operations86	<VTR MENUS>	
Basic setting menu operations87	VTR MAIN MENU screen113
Displaying sub-menus and deciding on settings88	FUNCTION screen114
Setting menu configuration89	BATTERY/TAPE screen115
Setting menu screens93	BATTERY SETTING screen116
<FILM (CAM) MENUS>		VTR VF INDICATOR screen117
FILM (CAM) MAIN MENU 1 screen93	MIC/AUDIO screen117
FILM (CAM) MAIN MENU 2 screen93	TC/UB screen119
FILM (CAM) MAIN MENU 3 screen93	TIME DATE screen121
FILM (CAM) MAIN MENU 4 screen93	VTR USER MENU SELECT screen121
FILM (CAM) MAIN MENU 1		VTR CARD READ/WRITE screen121
ROP screen94	VTR INITIALIZE screen121
MATRIX screen94	DIAGNOSTIC screen121
COLOR CORRECTION 1 screen95	<VTR USER MENU SELECT>	
COLOR CORRECTION 2 screen95	FUNCTION screen122
LOW SETTING screen96	BATTERY/TAPE screen122
MID SETTING screen96	VTR VF INDICATOR screen123
HIGH SETTING screen97	MIC/AUDIO screen123
ADDITIONAL DTL1 screen97	TC/UB screen123
ADDITIONAL DTL2 screen97	Warning system124
SKIN TONE DTL screen98	Emergency eject126
KNEE/LEVEL screen98	Error codes126
GAMMA screen99	Maintenance127
CAMERA SETTING screen99	Condensation127
FILM (CAM) MAIN MENU 2		Head cleaning127
VF DISPLAY screen100	Cleaning inside the viewfinder127
VF MARKER screen101	Phenomena inherent to CCD cameras127
VF INDICATOR screen101	Replacing the backup battery127
CAMERA ID screen102	Inspections prior to shooting128
SHUTTER SPEED screen102	Preparation for inspection128
SHUTTER SELECT screen103	Inspecting the camera unit128
!LED screen104	Inspecting the viewfinder129
CAMERA SW MODE screen104	Inspecting the aperture and zoom functions130
SUPER GAIN screen106	Inspecting the VTR unit130
FRAME MODE screen106	Specifications132
FILM (CAM) MAIN MENU 3			
CAM CARD READ/WRITE screen107		
CAM CARD R/W SELECT screen107		
GENLOCK/IRIS screen108		
LENS ADJ screen108		
FILM (CAM) MAIN MENU 4			
FILM (CAM) USER MENU SELECT 1 screen109		
FILM (CAM) USER MENU SELECT 2 screen109		
FILM (CAM) USER MENU SELECT 3 screen109		
BLACK SHADING screen110		
WHITE SHADING screen110		
FLARE screen110		
COLORIMETRY screen110		
INITIALIZE screen110		
DIAGNOSTIC screen111		
EVALUATION screen111		
OPTION screen111		

Introduction

The AJ-HDC27F is a camera/VTR that supports the SMPTE-296M 1280×720 scanning standard.

Integrated in this single unit are an HD colour video camera featuring a 1-million pixel IT-CCD unit with on-chip lens as the pickup device, and a DVCPRO HD format VTR incorporating the latest compression technology.

The camera unit supports a variable frame function and film tone gamma function, and it also supports the Ultra Prime lenses for 35 mm film cameras as a standard feature.

Featuring a 100 Mbps recording rate for the VTR as well, this unit is capable of recording images with an extremely high picture quality to achieve the highest performance and most sophisticated functions as an integrated camera/VTR for electronic field production (EFP) applications.

Furthermore, it is compact and lightweight, has low power consumption, and excels in achieving a high level of picture quality, sensitivity, and mobility, and is extremely dust-proof and moisture-proof. These are all attributes which enable the unit to be used for electronic news gathering (ENG) applications as well. Since digital signal processing is provided in both the camera unit and VTR unit, the picture quality is further improved while the unit's stability is also enhanced. Small multimedia cards or SD memory cards meeting global standards can be used for the camera and VTR setting data as part of a system which can accomplish data management.

Features

Features of the camera unit

The camera unit of the AJ-HDC27F has the following features.

- High sensitivity: 2000 lux, F12
- Frame rate: 4 fps (frame/sec.) to 60 fps
- High signal-to-noise ratio: 54 dB (standard)
- Low smear
- Low flare
- Scan reverse
- Switchable frame frequency: 60.00 Hz or 59.94 Hz

Variable frame rate

Frame-drop (under-cranking) shooting and high-speed (over-cranking) shooting, which are special film shooting techniques, have been achieved for the first time in a video camera.

The variable frame rate function can be set as desired from 4 fps (frame/sec.) to 60 fps.

The shutter speed can also be set from 0.8% of the frame rate (aperture angle: 3 degrees) to 97.2% (aperture angle: 350 degrees), enabling full use to be made of many different presentation techniques.

Along with continually recording at 60 fps, the VTR unit enables specific effective frames alone to be marked with time codes so that off-line editing using a conventional DVCPRO HD VTR is possible. This makes it possible to construct a 24 fps production system with minimal equipment investment.

Film tone gamma function

In the beginning, the first and foremost aspect defining the manifold powers of expression that only the medium of film could achieve was the extent of a film's latitude (reproduction range). What Panasonic did was to use its resources to develop an exclusive gamma curve for reproducing film tones by means of the CCDs, and this led to the capability of expressing natural gradations and reproducing a rich variety of colours—something that was beyond the means of conventional video cameras. The AJ-HDC27F incorporates a total of three gamma curves—two cine curves (for films/for videos) and the conventional video gamma curve—and it enables the curve that best suits the application at hand to be selected. The powers of expression achieved as a result are comparable to those provided by film. The high sensitivity that is simply superior to film cameras delivers an excellent balance between brightness and high picture quality: indeed, the kind of sensitivity that corresponds to ISO640 enables shooting with the same kind of feel as ultra-fine-grain films.

When the conventional video gamma curve is to be used, set the unit to the video mode using the CAM MENU SEL item on the OPTION screen of FILM (CAM) MAIN MENU 4.

When one of the cine curves is to be used, set the unit to the film mode using the CAM MENU SEL item on the OPTION screen of FILM (CAM) MAIN MENU 4, and then select the desired curve by setting the CINE GAMMA SEL item on the GAMMA screen of FILM MAIN MENU 1.

Features

Features of the camera unit

Prime lens mode

Not only the lens that does justice to the sensitivity equivalent to a film but also the various devices and equipment that are peripheral to the camera combine to play roles which are so critical that they cannot be divorced from the technical skills of the person operating the camera. Using an HD lens adapter made by Angenieux, this unit supports the ultra-prime lenses used for film cameras as a standard feature. What's more, Panasonic has achieved an industry first by incorporating as a standard feature, a scan reverse function, which cancels out image reversal occurring when the adapter is used, and switching can be easily accomplished by a menu setting.

The unit also supports slide bases, matte boxes and other film camera equipment which users may have been using for years.

A full range of long viewfinders, small LCD monitors and other options available from related manufacturers is available, and the maximum can be derived from formats ranging from films to HD with the same ease afforded by simply changing the main camera unit.

Film user menu

Panasonic does its best to cater to film camera users not only on the functions and performance front but also in terms of operation.

For instance, it has provided a cinema image menu (FILM USER MENU) which brings together on one page the setting items that are frequently used in location cinema shooting.

Along with the gamma curve selection and scan reverse ON/OFF functions, the settings for the hard and soft texture adjustments, gradation settings for the shadow areas, latitude adjustments, and tungsten lighting (3200K) type or daylight (5600K) type can be selected just like with films on one menu screen.

Digital signal processing

Analogue signals are converted into digital signals through 10-bit A/D conversion at a sampling frequency of 74.1758 MHz (59.94 Hz)/74.25 MHz (60.0Hz).

This processing not only enhances the picture quality, stability and reliability but it also enables the viewfinder screen displays and many of the adjustment and setup items to be configured in a menu-driven format.

4-piece filter disc sets available as standard accessories

The filter best suited to the subject's brightness and colour temperature can be selected. Two independent sets of filter discs, one for CC and one for ND, each with four filter discs, are provided as standard accessories.

Camera unit equipped to capture a wide range of image creation activities from cinema production to broadcasting applications

- A sensitivity of F12 (2000 lux) achieved by the three highly sensitive CCDs.
The minimum subject brightness is 0.7 lux.

- Gamma curves (switchable) for reproducing film tones.

- Not only a natural choice like 24 fps (frame/sec.) for films but also any number of shooting frames from 4 fps to 60 fps can be set.

- Digital setup for controlling image production using numerical values and for simple operation using the jog dial and gradation menu.

- Cinema image menu provided for film producers.

- Setup data in up to 8 files can be stored on an SD card (optional accessory: RP-SD008B).

- Built-in high picture quality circuits including auto knee, many different detail functions, shading compensation, 12-axis colour compensation circuit and masking circuit.

- Built-in 2-level zebra pattern and spot zebra functions.

- 3 values among the 10 possible settings from -6 dB (-3 dB in film mode) to +30 dB allocated to the gain selector; also, the gain can be increased up to +36 dB by the super gain function.

- The following functions can be allocated to the USER1 and USER2 buttons: super iris, super gain, super black, black stretch, audio CH1/CH2 input front/rear switching, recording start/stop, return switch, and Y GET (output luminance level measurement).

- An electronic shutter with a variable function

0.8% to 97.2% of the frame rate (aperture angle of 3.0 to 350.0 degrees)
--

over and above the 6 shutter speeds.

1/100 , 1/120, 1/250, 1/500, 1/1000 and 1/2000 sec. (or 180.0, 172.8, 144.0, 120.0, 90.0 and 45.0 deg)

- Tungsten lighting (3200K) type or daylight (5600K) type can be selected just like with films on one menu screen. Two sets of ND&CC optical filters are featured as a standard option.

- ABB (automatic black balance) and AWB (automatic white balance) functions incorporated.
Two values for each of the four CC filters can be retained as the AWB values.

- Statuses and warnings are displayed on the viewfinder screen.

Features

Features of the VTR unit

Digital system

The pictures are compressed by a component digital recording system that uses the latest compression technology while non-compression PCM recording featuring excellent signal-to-noise ratio, frequency band, waveform characteristics and reproduction of detailed areas is employed for the sound. The result is an even higher picture and sound quality.

Power saving management (SAVE REC) function

When this unit is used for recording, its playback system circuitry is shut down. The output of signals to the HD SDI OUT connector is also shut down when the cable has not been connected so that the unit's power can be conserved while the unit is being operated.

Scene-to-scene continuity

Simply by pressing the VTR START button or lens VTR button, continuity between the scenes is obtained at a precision of 0 to +1 frame.

Rec review function

The last 2 to 10 seconds of a recording are automatically rewound and played back to enable the user to quickly check what has been recorded.

Playback function

This function enables the playback picture (in black and white) to be viewed on the viewfinder screen. Colour playback pictures can be output from the HD SDI OUT connector.

Built-in time code generator/reader

The same or separate time code information can be recorded on the dedicated sub-code track and video AUX area, and played back.

External locking of time code

The built-in time code generator can be locked to an external generator. A lithium battery is used as the backup power supply of the built-in time code generator to back up the memory data for about a year even when no power is supplied to the unit.

Tape management information

As the tape management information, this unit automatically saves the frame rate information on the shooting speeds, the active frame information on the first frame where the frame image was switched, and the active frame count information in the user's bit of the sub-code track area (which used to be the LTC area).

Built-in DOLBY NR system

The cue audio recording circuitry contains a Dolby B noise reduction circuit.

Audio functions

- A phantom power supply type of microphone (optional accessory) with sharp directivity characteristics can be attached. It can also be detached from the unit for use as an interview microphone.
- Other kinds of microphones can also be connected and, using the model AJ-MH700P microphone holder (optional accessory), attached to the unit.

NEWS REC function

This function especially supports shooting in the context of news gathering or documentary filming to ensure that no opportune shutter opportunities are passed up.

In other words, by controlling the start key acknowledgment time, the unit can continuously record without the user having to interrupt the recording: this safeguards against the failure to record those precious moments—a failure that occurs when recording is resumed after it has been shut down temporarily.

RETAKE function

This function is for not leaving behind superfluous cuts when a cut turns out to be no good during the shooting of news, reports or art programmes.

Users should remember to handle this function very carefully.

If there is enough leeway in the shooting time and a particular cut is clearly judged to be no good, the tape is rewound to the start of the cut concerned and the rec pause (rec standby) mode is established by operating the MODE CHECK button and lens RET button. Since recording is now commenced from that point on the tape, the no-good cut will be deleted. In order to prevent the cut prior to the no-good cut from being deleted, a part of the no-good cut equivalent to ten or so frames is left behind.

By cutting down on the time taken for copying onto the work tape, for instance, this function is very effective in achieving economical operation.

INTERVAL REC function

This function makes simple interval shooting possible. It proves to be very effective when shooting programmes with a nature theme or art programmes.

- Dolby noise reduction manufactured under license from Dolby Laboratories Licensing Corporation.
- "DOLBY" and the double-D symbol  are trademarks of Dolby Laboratories Licensing Corporation.

System configuration

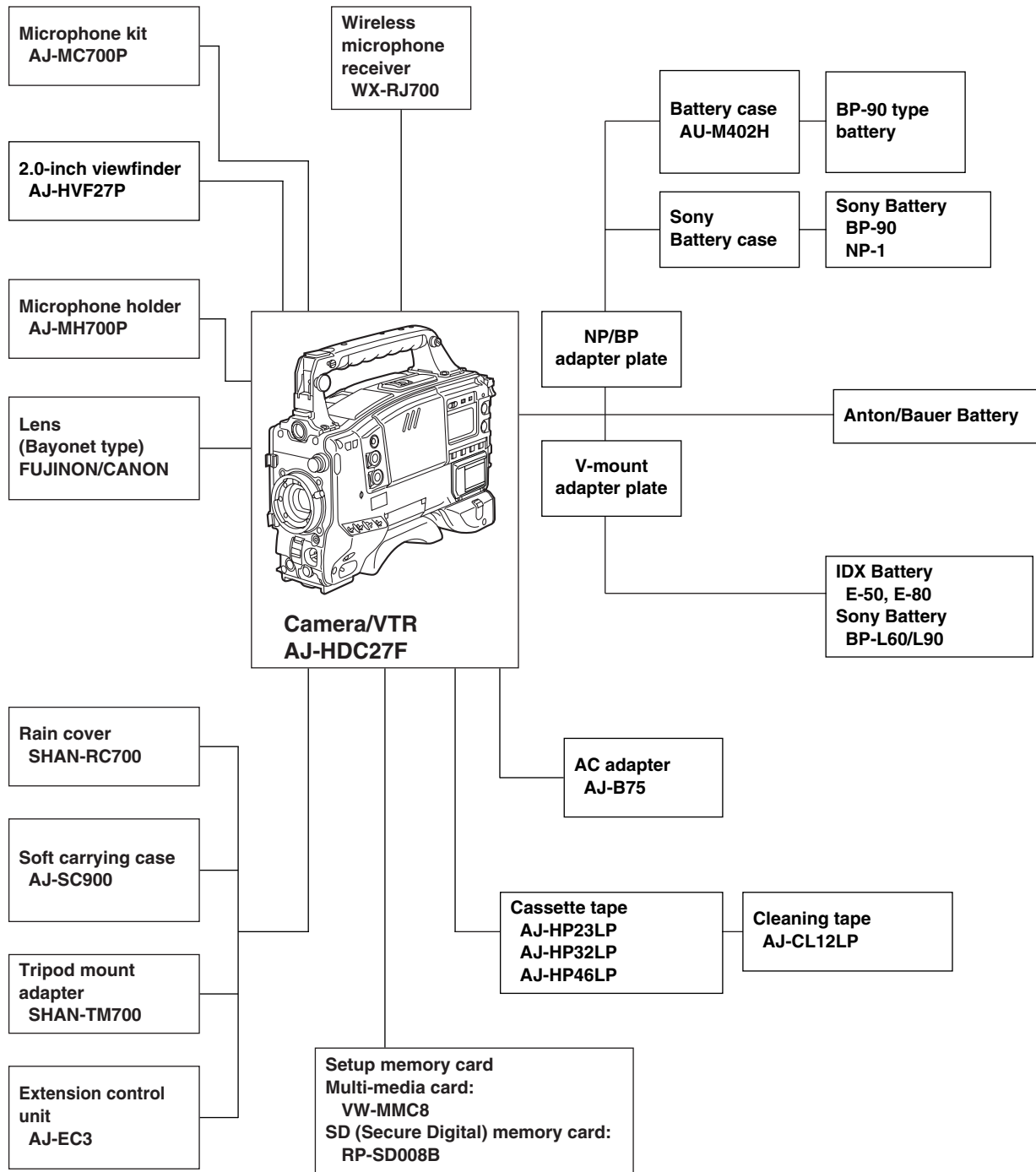

Parts and their functions

Power supply section

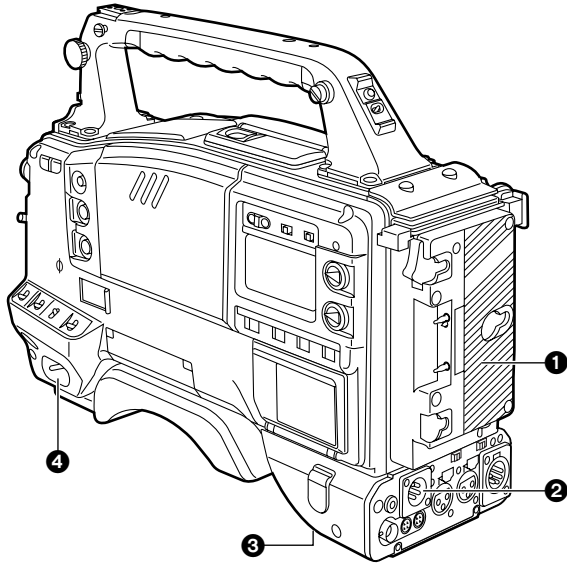

① Battery mount

This is for attaching the Anton/Bauer battery pack.

② DC IN (external power input) socket (XLR, 4P)

When operating this unit using an AC power source, this socket is connected to the model AJ-B75 AC adapter (optional accessory).

③ BREAKER button

To protect the equipment, the circuit breaker is tripped when an overcurrent flows inside the unit, and the power is automatically turned off. Push this button to the pushed-in position after performing internal inspections and adjustments. If there is no problem, the power will be turned back on.

④ POWER switch

ON : Set here to turn on the power.

OFF: Set here to turn off the power.

Parts and their functions

Accessory mounting section

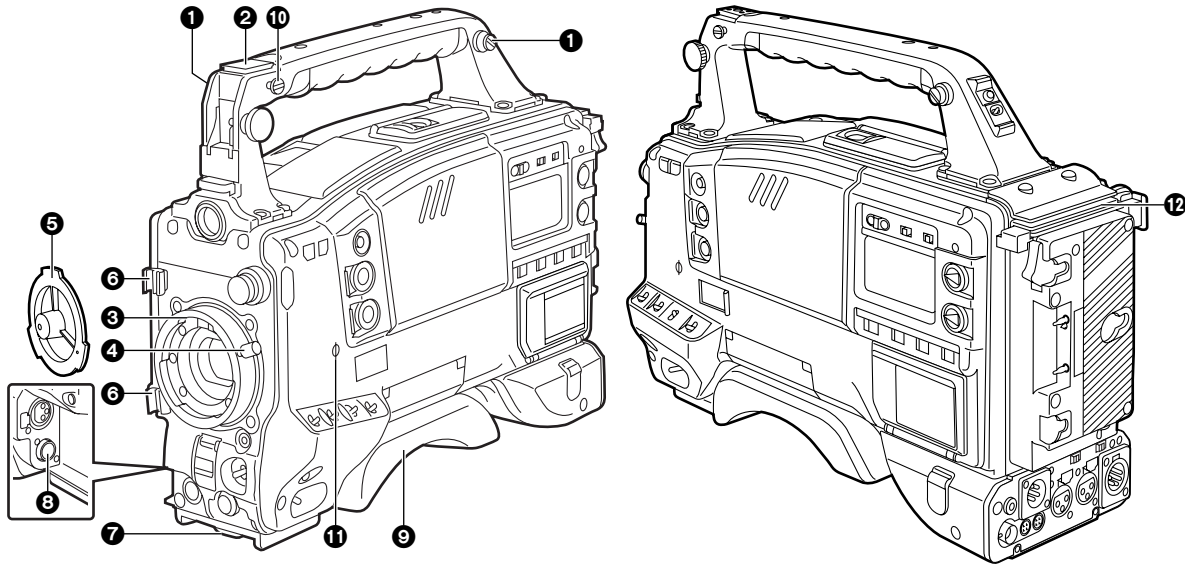

① Hooks for attaching shoulder strap

Attach the ends of the accessory shoulder strap to these hooks.

② Light shoe

Use this to attach the video light, etc.

③ Lens mount (Bayonet type)

Use this to attach the lens.

④ Lever for securing lens

Insert the lens into the lens mount ③, and turn the lens mount ring using this lever to secure the lens.

⑤ Lens mount cap

To remove the cap, push the lever for securing the lens ④ up.

Keep the cap in place while the lens is not attached.

⑥ Lens cable/microphone cable clamp

This clamp is for anchoring the lens cable or microphone cable.

⑦ Tripod mount

Mount the tripod attachment (SHAN-TM700), available as an optional accessory, when the unit is to be anchored to the tripod.

⑧ LENS terminal (12-pin)

The connecting cable of the lens is connected here. For details concerning the lenses that can be used, consult your dealer.

⑨ Shoulder pad

This pad can be adjusted to facilitate operation when the unit is operated on the user's shoulder.

The pad position can be moved forward or backward when the two securing screws are loosened.

⑩ Mounting hook for tape measure

The tape measure used to measure the subject distance is attached here.

<Note>

This hook is not to be used for the shoulder strap.

⑪ Focus mark

This indicates the focus position of the CCD unit.

⑫ Spacer to support extension unit

Future plans call for this connector to be used to support some options.

Parts and their functions

Audio function section (1)

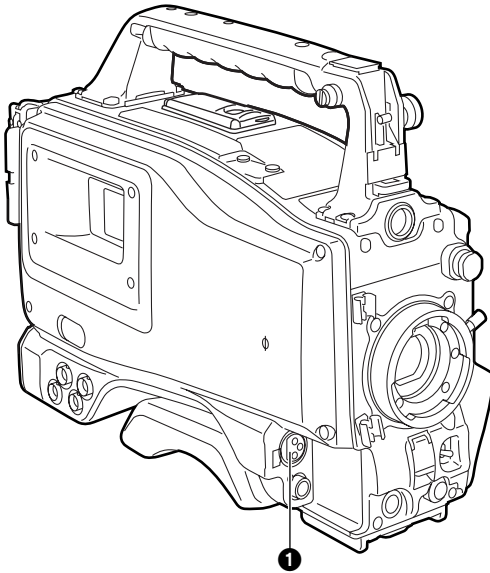

1 MIC IN (microphone input) jack (XLR, 3-pin)
Connect the microphone (optional accessory) here. The power for the microphone is supplied from this jack.

2 AUDIO LEVEL CH1/CH2 (audio channel 1 & 2 recording level adjustment) controls
When the AUDIO SELECT CH1/CH2 switch **3** is set to MAN, the recording level of audio channels 1 and 2 can be adjusted using these controls.

3 AUDIO SELECT CH1/CH2 (audio channel 1 & 2 automatic/manual level adjustment selector) switch
This is used to select the method for adjusting the audio levels of audio channels 1 and 2.
AUTO : Set here for automatic adjustment.
MAN : Set here for manual adjustment.

4 AUDIO IN (audio input selector) switch
This is used to select the input signals to be recorded on audio channels 1 and 2.
FRONT : The input signals supplied from the microphone which has been connected to the MIC IN jack **1** are recorded.
REAR : The audio input signals supplied from the audio component which has been connected to the AUDIO IN CH1/CH2 connectors **5** is recorded.

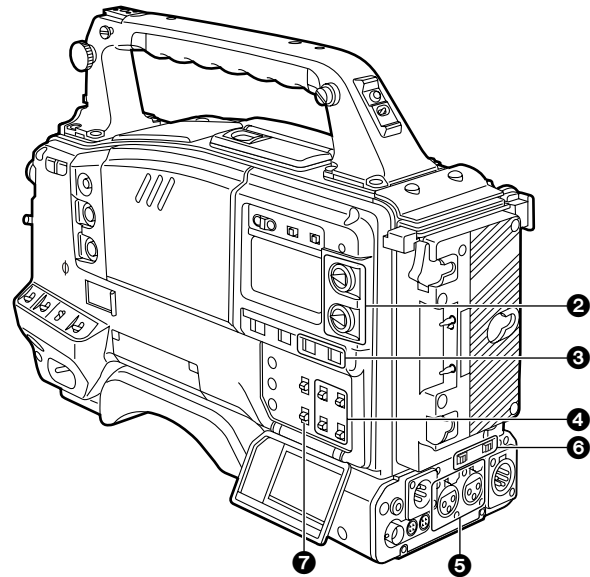

5 AUDIO IN CH1/CH2 (audio input channel 1 & 2) connectors (XLR, 3-pin)
An audio component or microphones are connected here.

6 LINE/MIC/+48V (line input/mic input/mic input + 48V) selector switch
This is used to switch the audio input signals from the audio component which has been connected to the AUDIO IN CH1/CH2 connectors **5**.
LINE : The audio input signals from the audio component serving as the line input are selected.
MIC : The audio input signals from the internal power supply type of microphone are selected. (The phantom mic power is not supplied from the unit.)
+48V : The audio input signals from the external power supply type of microphone are selected. (The phantom mic power is supplied from the unit.)

7 CUE switch
CH1 : The audio CH1 signals are recorded on the cue track.
MIX : Audio CH1 and CH2 mixed signals are recorded on the cue track.
CH2 : The audio CH2 signals are recorded on the cue track.

<Note>

This switch can be made ineffective using the VTR MAIN MENU. (See page 118)

Parts and their functions

Audio function section (2)

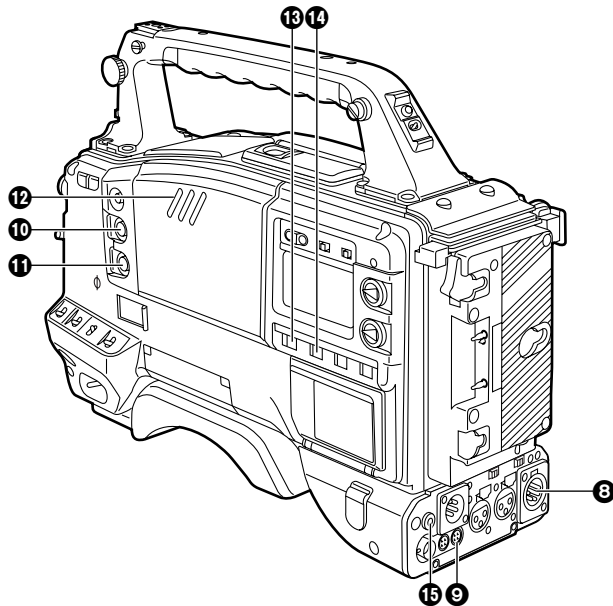

8 AUDIO OUT connector (XLR, 5-pin)

This is connected to the audio component. The sound of audio CH1 and the sound of audio CH2 are output separately. The switching of the recording sound and playback sound is coupled with the setting of the MONITOR OUT SDI switch. (No sound will be output when the SDI switch is at OFF.)

9 DC OUT (DC power output) socket

This is the DC 12 V output socket. A current of approximately 400 mA can be supplied.

10 ALARM (warning alarm volume adjustment) control

This is used to adjust the volume of the warning alarms from the earphone which has been connected to the speaker 12 or PHONES jack 15. The warning alarms are not audible when this control is at its lowest setting.

11 MONITOR (volume adjustment) control

This is used to adjust the volume of all the sound delivered through the speaker or earphone except for the warning alarms. The sound is not audible when this control is at its lowest setting.

12 Speaker

The EE sound during recording or the playback sound during playback can be monitored through this speaker.

The warning alarms are output in synchronization with the flashing or lighting of the warning lamps and warning displays.

The sound heard from the speaker is automatically cut off when the earphone is connected to the PHONES jack 15.

13 MONITOR SELECT (audio channel selector) switch

This is used to select the audio channels whose sound is to be output from the speaker or earphone.

CH1: The audio CH1 signals are output.

1/2: The audio CH1 and CH2 mixed signals or stereo audio signals are output. However, only mixed signals are output through the speaker.

CH2: The audio CH2 signals are output.

14 MONITOR (audio selector) switch

This is used to select the sound which is to be output to the earphone when "1/2" has been selected by the MONITOR SELECT switch 13.

ST: The audio CH1 and CH2 stereo audio signals are output.

MIX: The audio CH1 and CH2 mixed audio signals are output.

15 PHONES (earphone) jack (mini jack)

When an earphone (optional accessory) is connected, the sound selected by the MONITOR switch 14 can be heard from the earphone. In addition, the warning alarms relating to the unit's operations or statuses can be heard through the earphone. An earphone which is capable of delivering a sufficiently high volume is recommended. However, when the earphone is connected, the sound heard through the speaker 12 will be automatically cut off.

Parts and their functions

Viewfinder section

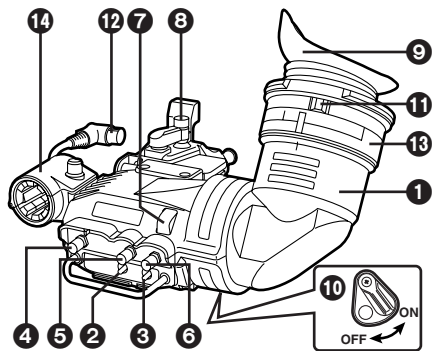

(Viewfinder pictured here is the AJ-HVF27P)

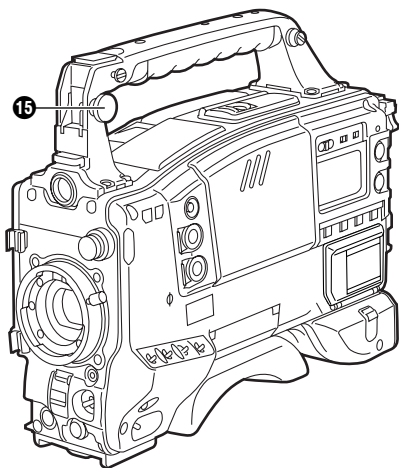

(For details concerning the viewfinder, refer to the operating instructions of the viewfinder.)

1 Viewfinder (optional accessory)

While recording or playback is underway, pictures can be viewed through the viewfinder in black and white. The warning displays concerning the unit's operation statuses and settings, messages, zebra patterns and markers (safety zone markers and centre marker) can also be seen in the viewfinder.

2 ZEBRA (zebra pattern) switch

This is used to display the zebra pattern in the viewfinder.

ON : The zebra pattern is displayed.

OFF: The zebra pattern is not displayed.

When the unit is shipped, the zebra pattern is set so that an area of less than 85% is displayed with a video level of at least 80% or so.

The required area of zebra pattern can be displayed by setting the ZEBRA 1 DETECT, ZEBRA 2 DETECT and ZEBRA 2 items on the FILM (CAM) MAIN MENU 2 screen.

3 TALLY switch

This is used to control the front tally lamp 7.

HIGH : The brightness of the front tally lamp is increased.

OFF : The front tally lamp is turned off.

LOW : The brightness of the front tally lamp is reduced.

4 PEAKING control

This is used to adjust the outlines of the images seen inside the viewfinder to make focusing easier. Its adjustment does not affect the output signals of the camera.

5 CONTRAST control

This is used to adjust the contrast of the picture seen inside the viewfinder. Its adjustment does not affect the output signals of the camera.

6 BRIGHT control

This is used to adjust the brightness of the picture seen inside the viewfinder. Its adjustment does not affect the output signals of the camera.

7 Front tally lamp

This lamp is activated when the TALLY switch 3 is set to the HIGH or LOW position, and it lights while the VTR unit is recording. It also flashes to provide a warning display like the REC lamp inside the viewfinder. The lamp's brightness when it is lit can be selected using the TALLY switch (HIGH or LOW).

8 Lever for securing the viewfinder in the back/front and sideways directions

This lever is loosened when the viewfinder position is to be adjusted in the back/front and/or sideways directions.

9 Eyepiece

10 Back tally lamp

This lamp lights while the VTR unit is recording. It also flashes to provide a warning display like the REC lamp inside the viewfinder.

When the lever is set to OFF, the back tally lamp is hidden.

11 Diopter adjustment ring

This is adjusted in line with the camera operator's diopter in such a way that the user can see the image on the viewfinder screen most clearly.

12 Connecting plug

13 Locking ring

14 Microphone holder

15 Viewfinder stopper screw

To detach the viewfinder from the camera, first loosen the stopper screw, and then remove the viewfinder.

Parts and their functions

Shooting (recording)/playback function section (1)

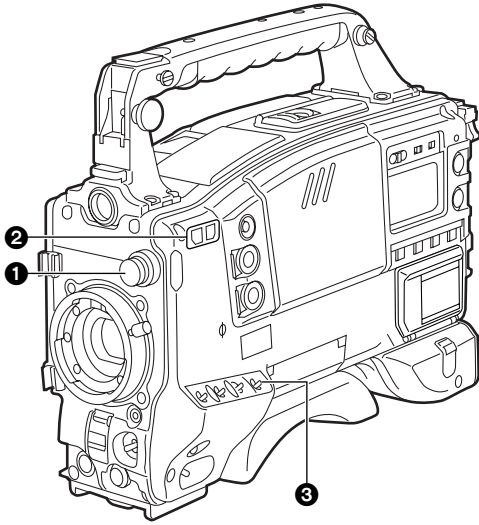

1 CC FILTER/ND FILTER (filter selector) control

This is used to select the filter to match the light source which is illuminating the subject. If the control setting is changed while the menu display mode is set to “3” (default setting), the new setting will appear at the setting change message display area of the viewfinder screen.

■ Control settings and filter selection

CC FILTER control (large diameter) setting	CC filter selection
A	Cross filter
B	3200 K
C	4300 K
D	6300 K

<Note>

The colour temperatures shown above are those when the LIGHTING item is set to TUNGSTEN or the D5600K item is set to OFF on the CAMERA SETTING screen of FILM (CAM) MAIN MENU 1.

ND FILTER control (small diameter) setting	ND filter selection
1	CLEAR (Transparent)
2	1/4 ND
3	1/16 ND
4	1/64 ND

- The two types shown above are provided for filter combinations.

■ Examples of filter selection

Shooting conditions	CC filter	ND filter
Sunrise, sunset, inside a studio	B (3200 K)	1 (CLEAR)
Outdoors under a clear sky	C (4300 K) or D (6300 K)	2 (1/4 ND) or 3 (1/16 ND)
Outdoors under cloudy or rainy skies	D (6300 K)	1 (CLEAR) or 2 (1/4 ND)
Snowscapes, high mountains, seashores or other perfectly clear scenery	C (4300 K) or D (6300 K)	3 (1/16 ND) or 4 (1/64 ND)

2 Synchro scan adjustment switches

These switches become effective when the shutter switch 7 is set to ON and SYNCHRO SCAN 2 is selected. They are used to adjust the synchro scan speed.

When the “-” switch is pressed, the shutter speed is reduced; conversely, when the “+” switch is pressed, it is increased.

During personal computer monitor shooting, etc. adjust these switches to the positions where the horizontal bar noise inside the viewfinder is decreased.

3 WHITE BAL (white balance memory selector) switch

PRST : Set the switch to this position in cases where there is not enough time to adjust the white balance. The TUNGSTEN (3200 K) white balance value is stored in the memory.

This can be changed to DAY LIGHT (5600 K).

A or B : When the AUTO W/B BAL switch 6 is set to AWB, the white balance is automatically adjusted to match the setting position of the CC FILTER control 1, and the adjustment value is stored in memory A or memory B.

When the CC FILTER control and the WHITE BAL switch are set to the same positions as they were when adjustment was performed, the adjustment value stored in the memory is recalled, and the unit is automatically adjusted to the white balance that corresponds to this value.

If this switch setting is changed while the menu display mode is set to “3” (default setting), the new setting will appear at the WHITE BAL switch display position on the viewfinder screen.

(Example: “A”)

Parts and their functions

Shooting (recording)/playback function section (2)

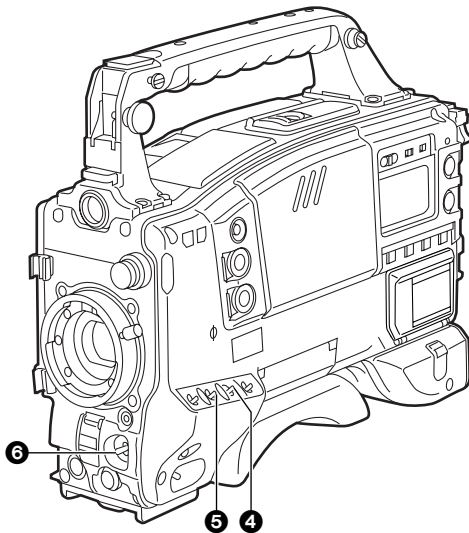

④ OUTPUT (output signal selector)/AUTO KNEE switch

This is used to select the video signals which are to be output from the camera unit to the VTR unit, viewfinder and video monitor.

The AUTO KNEE function can be used when the pictures shot by the camera are selected.

The operation of the AUTO KNEE function can be selected using the AUTO KNEE SW item on the CAMERA SW MODE screen of FILM (CAM) MAIN MENU 2.

(The factory setting of the AUTO KNEE function is OFF.)

■ OUTPUT/AUTO KNEE switch setting position

BARS	Colour bar signals are output. The AUTO KNEE circuit is not activated. Use this position in the following circumstances. <ul style="list-style-type: none"> • When the video monitor is to be adjusted • When the colour bar signals are to be recorded
CAM. AUTO KNEE OFF	The pictures shot by the camera are output. The AUTO KNEE circuit is not activated. MANUAL KNEE is selected as the default setting.
CAM. AUTO KNEE ON	The pictures shot by the camera are output. The AUTO KNEE circuit is activated.

AUTO KNEE function

If the level is adjusted to people or scenery for shooting when the background is very bright, the background becomes subject to white-out, causing the buildings and scenery in the background to be blurred. When the AUTO KNEE function is activated in a situation like this, the background can be reproduced distinctly.

This function is very effective for shooting in the following situations.

- When shooting people in the shade under a clear sky
- When shooting people inside a vehicle or a building and outdoor scenery seen through windows at the same time
- When shooting scenes with a high contrast

⑤ GAIN (gain selector) switch

This is used to select the gain of the video amplifier in accordance with the lighting status during shooting. The gain values corresponding to the L, M and H settings are specified by the setting menu ahead of time.

If this switch setting is changed while the display mode is set to “3,” the new setting will appear at the gain display position on the viewfinder screen. (Example: “12 dB”)

⑥ AUTO W/B BAL (automatic white balance/black balance adjustment) switch

AWB: This is selected when the white balance is to be adjusted automatically. When the WHITE BAL switch ③ is set to “A or B” at this time, the adjusted value will be stored in memory A or memory B.

ABB: This is selected for automatically adjusting the black balance.

The adjusted value is stored in a dedicated memory.

Black shading is automatically corrected when SHD and ABB SW CTRL on the OPTION screen of FILM (CAM) MAIN MENU 4 are set to ON and the AUTO W/B BAL switch is pressed continuously for 8 seconds or more on the ABB side.

<Note>

When white balance or black balance are being automatically adjusted and the switch is pressed again to either the AWB side or to the ABB side, the automatic adjustment for the side pressed will be stopped.

The adjusted value in this case is the value before automatic adjustment was performed.

Parts and their functions

Shooting (recording)/playback function section (3)

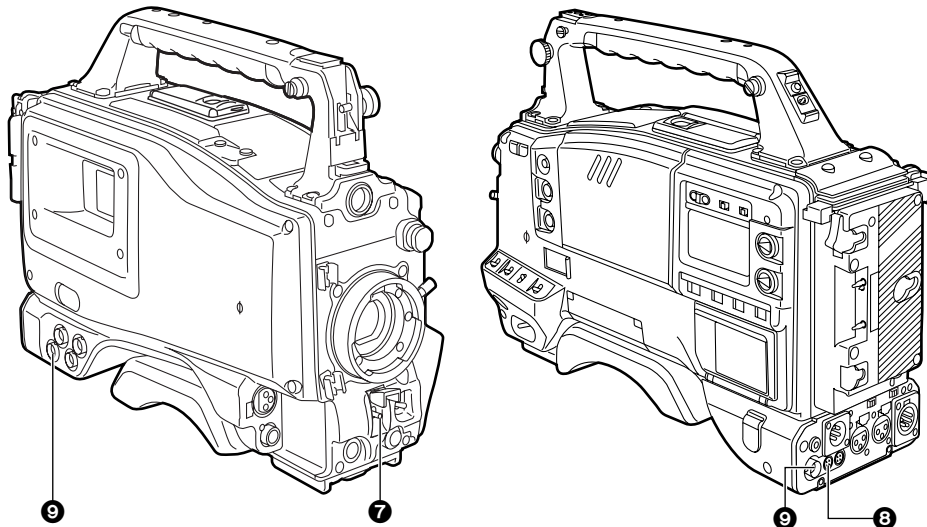

7 SHUTTER switch

This is set to ON when the electronic shutter is to be used. When the SEL side is pressed, the shutter speed and mode display are changed in the range which was set ahead of time in the setting menu.

If this switch setting is changed while the display mode is set to “2” or “3,” the new setting will appear at the shutter display position on the viewfinder screen.

(Example: “: 1/120”, “: 50%”, “: 180d”)

8 ECU REMOTE (remote control) connector (6-pin)

The AJ-EC3 extension control unit (optional accessory) is connected here.

<Note>

Before connecting or disconnecting the remote control cable, be absolutely sure to set the POWER switches on the unit and extension control unit to the OFF position.

9 HD SDI OUT connector (BNC)

The HD SDI signals (video and audio) for the monitor in accord with the position of the MONITOR OUT SDI switch 10 are output from here.

When the SDI switch is at “EE/PB,” the EE video and EE audio signals will be output during recording and the playback video and playback audio signals will be output during playback.

When the SDI switch is at “EE,” the camera video signals are output at all times.

When the CHARACTER switch is set to ON while performing the menu settings, it is possible to superimpose the setting menus onto the pictures being shot so that they can be checked on the monitor screen.

The user’s bit is also output from the HD SDI OUT connector.

The active frame count is output to the four higher digits of the user’s bit. The count is reset to zero each time recording starts, and the count is incremented with each active frame.

The active frame information is output to the lowest digit of the user’s bit while the frame rate information is output to the third and fourth lower digits.

<Note>

In order for the time code that matches the playback time code, which is output from the HD SDI OUT connector, to be output from the TC OUT connector, set the SDI switch to “EE/PB,” and select “TCG/TCR” as the TC OUT item setting on the TC/UB screen.

Parts and their functions

Shooting (recording)/playback function section (4)

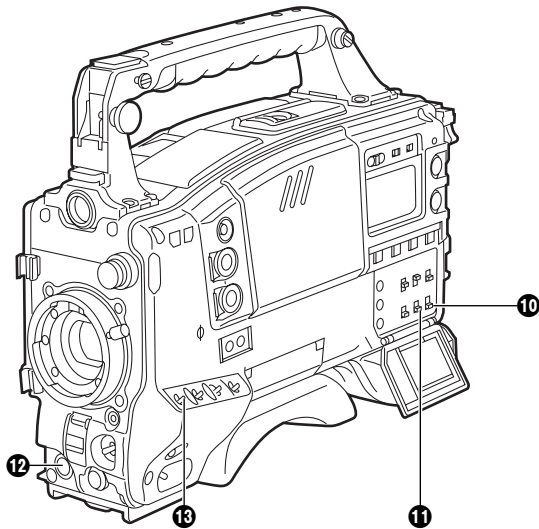

⑩ SDI switch

This is used to select the video and audio signals which are to be output from the HD SDI OUT connector and the audio signals which are to be output from the AUDIO OUT connectors.

EE/PB: During playback, the playback video and playback audio signals are output; in all other modes, the EE video and EE audio signals are output.

EE : The EE video and EE audio signals are output at all times.

OFF : Signal output is stopped. (This serves effectively as a power-conserving mode.)

<Notes>

- With the settings at shipment, this function does not work at the OFF position when a cable is connected to the HD SDI OUT connector. For further details, refer to the FUNCTION screen (page 114) of the VTR menu.

During recording, the HD SDI OUT output signals cannot be switched from ON to OFF or vice versa. The status set prior to the commencement of recording is maintained.

- When the frame frequency has been set to 60.00 Hz, the audio signals which are output from the HD SDI OUT connector can be controlled on the MIC AUDIO screen of VTR MENU.

However, it should be borne in mind that some products may not be able to process properly the audio signals which are output from the HD SDI OUT connector at this 60.00 Hz frequency setting.

For details, consult your dealer.

⑪ CHARACTER switch

This controls whether the characters are to be superimposed onto the pictures which are output from the HD SDI OUT connector.

ON : The characters are superimposed.

OFF: The characters are not superimposed.

⑫ VTR START button

When this is pressed, recording starts; when it is pressed again, recording stops.

This button functions in the same way as the lens VTR button.

⑬ VTR SAVE/STBY (tape protection) switch

This is used to select the power supply mode when the VTR has temporarily stopped recording (REC PAUSE mode).

SAVE: This is the tape protection mode. The cylinder is stopped in the half-loading status. Less power is consumed than at the STBY position, and the operating time provided by the battery is prolonged. Compared with the STBY position, it takes longer for recording to commence after the VTR START button ⑫ has been pressed.

When the switch is set to this position, the VTR SAVE lamp inside the viewfinder lights.

STBY: At this position, recording is commenced as soon as the VTR START button is pressed.

<Note>

When the prescribed amount of time has elapsed in the STBY mode, the unit is automatically set to the SAVE mode. To return the unit to the STBY mode, set the VTR SAVE/STBY switch to SAVE, and then again to the STBY position.

Parts and their functions

Shooting (recording)/playback function section (5)

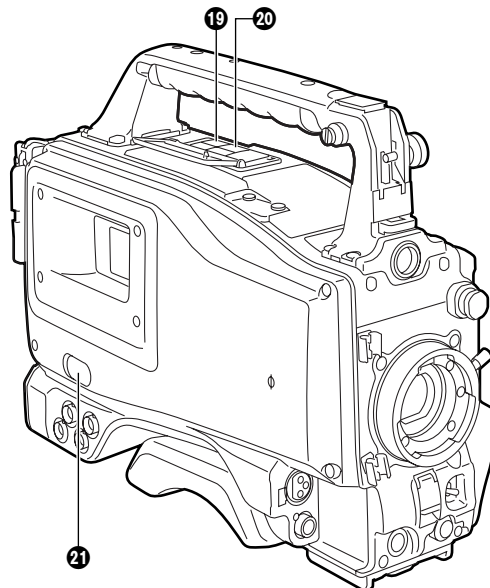
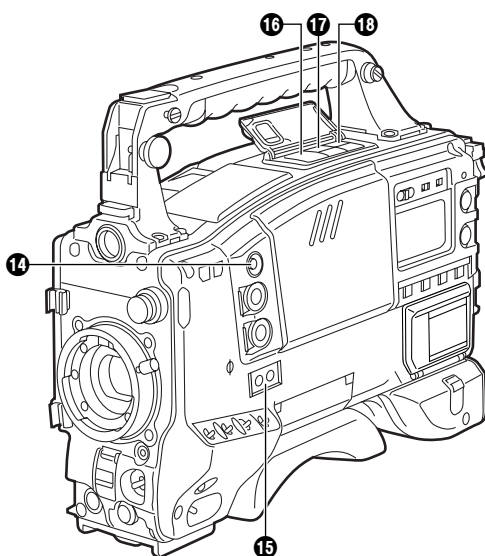

14 MODE CHECK button

While this button is held down, the camera's setting mode is shown in the viewfinder.

This does not affect the output signals of the camera.

15 USER 1 and USER 2 buttons

A user setting can be allocated to each of these buttons using the setting menu.

When a button is pressed, the user setting mode allocated to it is selected.

When the button is pressed again, the selected mode is released.

16 EJECT button

This is pressed to insert or eject the cassette.

17 REW button

This is pressed to rewind the tape. The button's lamp comes on during rewinding.

When it is pressed during playback, the tape will be reviewed (rewound and played back) at about twice the regular speed while the button is held down.

18 FF button

This is pressed to fast forward the tape. The button's lamp comes on during fast forwarding.

When it is pressed during playback, the tape will be cued (fast forwarded and played back) at about twice the regular speed while the button is held down.

19 PLAY/PAUSE button

This is pressed to view the playback picture on the viewfinder screen or using a colour video monitor.

The button's lamp comes on during playback.

When it is pressed during playback, the unit is set to pause in the playback mode (PLAY PAUSE), and the button's lamp flashes. If the unit is left in the pause mode for two minutes, it automatically changes to the stop (STOP) mode.

20 STOP button

This is pressed to stop the tape travel.

21 EMERGENCY screw (inside rubber cap)

If the cassette does not eject even when the EJECT button is pressed, use a screwdriver or similar implement to push and turn the EMERGENCY screw at the same time: this will cause the cassette to be ejected.

Parts and their functions

Warning/status display section

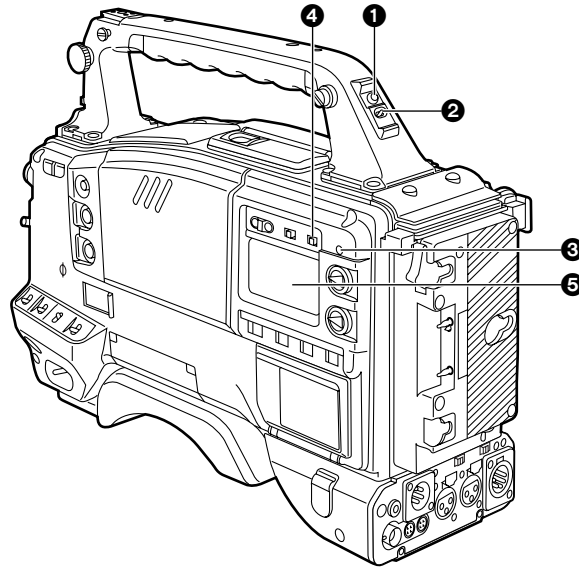

① Back tally lamp (unit)

When the back tally switch ② is set to ON, this lamp serves the same function as the front tally lamp in the viewfinder.

② Back tally switch

This is used to control the unit's back tally lamp ①.

ON : The unit's back tally lamp is operational.

OFF: The unit's back tally lamp is not operational.

③ WARNING lamp

When a problem of some form or other occurs within the VTR unit, this lamp flashes or lights.

④ LIGHT switch

ON : The display window ⑤ is illuminated.

OFF: The illumination of the display window is turned off.

⑤ Display window

This displays the alarms, remaining battery charge, audio levels, time data, etc. relating to the VTR unit.

Parts and their functions

Menu operation section

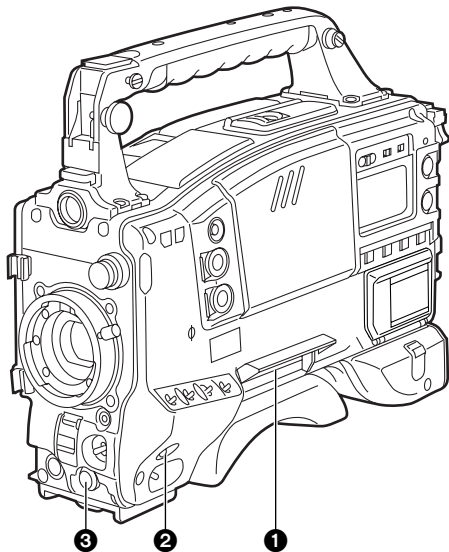

1 Setup card insertion slot

The setup card, available as an optional accessory, is inserted into this slot.

2 MENU button

When this is pressed, the camera unit's user menu screen, which was set at the time of shipment, appears.

When it is pressed again, the VTR unit's user menu screen appears.

When it is pressed once more, the menu screen display is cleared.

The selection of the menu for the user menu can be changed on the USER MENU SELECT screen.

When the power is turned on

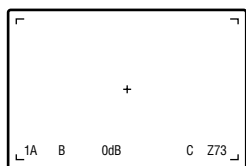

Status display

Press the MENU button.



Camera unit's user menu

Press the MENU button.



VTR unit's user menu

Press the MENU button.

3 JOG dial button

When this dial button is turned while the menu screen is displayed, the cursor is moved to each of the setting items.

The menu items are set by operating this dial button.

There are two types of menus, MAIN and SUB, and each menu is displayed on a page-by-page basis.

The menu configuration can be changed to suit the desired objective.

For details on the menu operation method, refer to "Menu operations" on pages 86 to 88.

Time code related section (1)

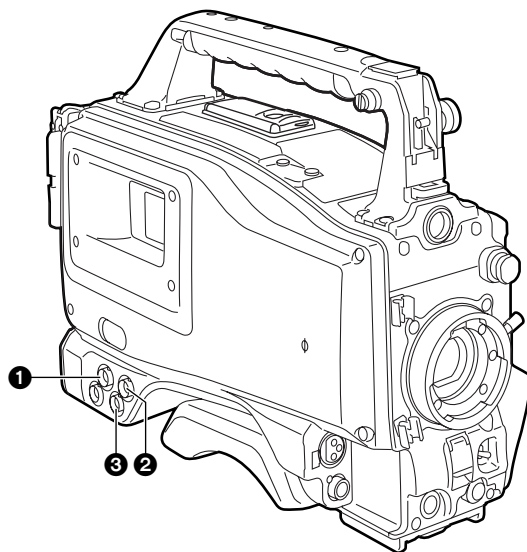

1 GENLOCK IN connector (BNC)

Supply the analogue HD reference signal to this connector for gen-locking the camera unit or when externally locking the time code.

<Note>

Enter the reference signal of the same frame frequency (59.94 Hz or 60.0 Hz) as the unit.

2 TC IN connector (BNC)

Supply the time code which will serve as the reference to this connector when externally locking the time code.

3 TC OUT connector (BNC)

To lock the time code of an external VTR to the unit's time code, connect this connector to the time code input (TC IN) connector on the external VTR.

Parts and their functions

Time code related section (2)

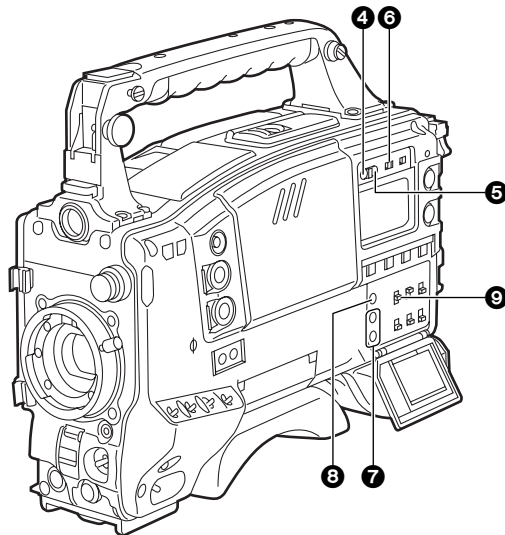

④ HOLD button

The time data display of the counter display section which was on the screen at the moment when this button is pressed is held. (However, the time code generator keeps running.) When the button is pressed again, the hold status is released.

It is used, for instance, to find out the time at which a particular scene was shot.

<Note>

If the HOLD button is pressed and held down while the DISPLAY switch ⑥ has been set to UB, "HOLD" on the counter display flashes, and the button functions to display the VITC user's bit information recorded in the video AUX area on the counter display section.

⑤ RESET button

This is used to reset the time data on the counter display section to "00:00:00:00." If it is pressed while the TCG switch ⑨ is at the SET position, the time code data and user's bit data are respectively reset to "00:00:00:00."

⑥ DISPLAY switch

This is used to display the time code, CTL or user's bit on the counter display section depending on the setting positions of this switch and the TCG switch ⑨.

⑨.

UB : The user's bit is displayed.

TC : The time code is displayed.

CTL : CTL is displayed.

⑦ "+" button, "-" button

These are used to increment or decrement by 1 the figure in the digit which was made to flash by the SHIFT button ⑧ when the time code or user's bit is to be set.

⑧ SHIFT button

This causes the digit to be set to flash when the time code or user's bit is to be set.

⑨ TCG (time code selector) switch

This is used to set the running mode of the built-in time code generator.

F-RUN : Set here to have the time code run all the time regardless of the VTR's operation.

This position is used to align the time code with the time or externally lock the time code.

SET : Set here when the time code or user's bit is to be set.

R-RUN : Set here to have the time code run only during recording.

The time code on the tape with scene-to-scene continuity is recorded continuously.

Power supply

A battery pack or an AC power source can be used as this unit's power supply.

To use the battery pack, there is a choice of makes of batteries below, namely:

- Anton/Bauer
- IDX
- Sony

<Note>

Batteries of other makes can also be supported by changing the setting menu but no guarantees are made for the system when they are actually used with this unit.

Before using the battery pack, recharge the battery using the battery charger.
(For details on the recharging method, refer to the operating instructions of the battery concerned.)

Using the Anton/Bauer battery pack

- 1 Attach the battery pack.
Insert the pack in the direction shown by the arrows, and then slide it into position.

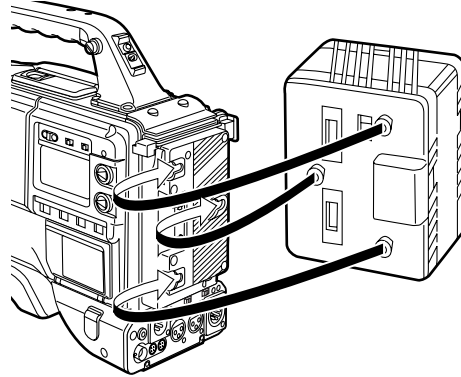

- 2 To detach the battery, pull the battery mount removal lever all the way down, and slide the battery pack in the direction shown by the arrow.

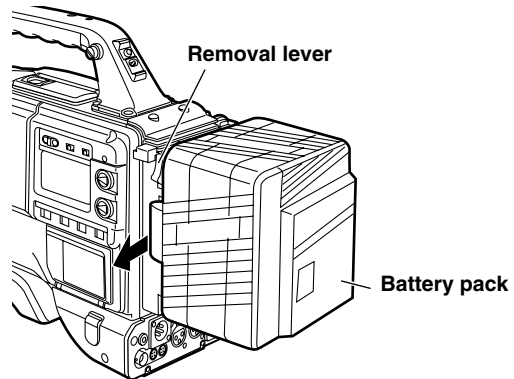

<Note>

An intelligent battery system and ultra light system are supported.

The remaining battery charge displayed inside the viewfinder is usually shown as a percentage of the full charge, but when the battery charge is nearly completely dissipated, the percentage display is replaced with a voltage display.

Power supply

Using the BP-90 type battery pack

- 1** Attach the NP/BP adapter plate. Insert it in the direction shown by the arrows, and slide it into place.

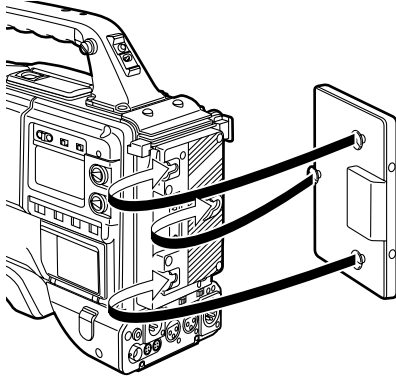

- 2** Attach the connectors provided with the NP/BP adapter plate to the positions shown in the figure.

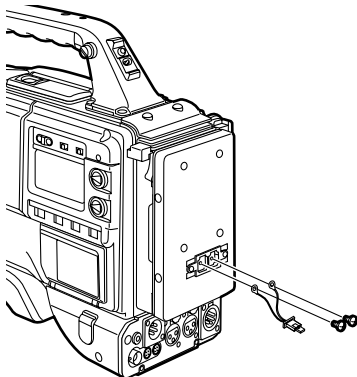

- 3** Connect these connectors with the connector on the AU-MA402H battery case.

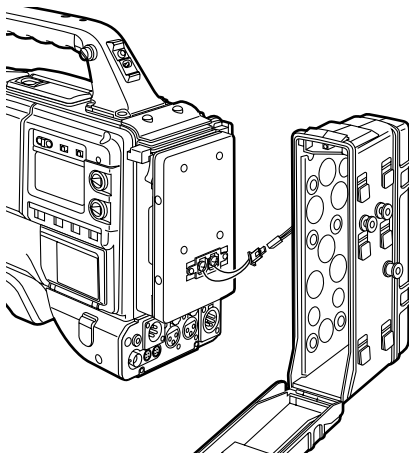

- 4** Attach the AU-M402H battery case. Open the battery case cover, and raise it above the rubber cap: screw holes will now be visible. Tighten the screws using a screwdriver, then attach the case to the NP/BP adapter plate and tighten the screws fully.

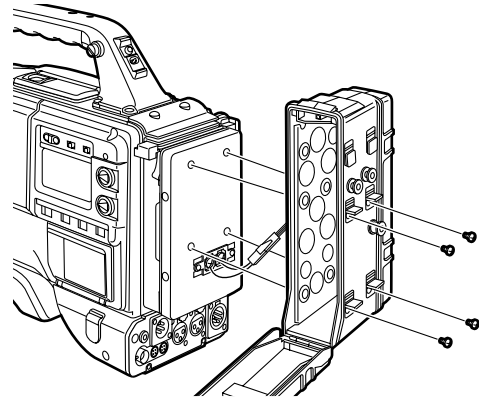

<Notes>

- Do not pull the rubber cap forcefully.
- When mounting the battery case, take care not to pinch the connecting cord.

- 5** Connect the plug on the battery pack to the connector inside the case, and insert the battery pack.

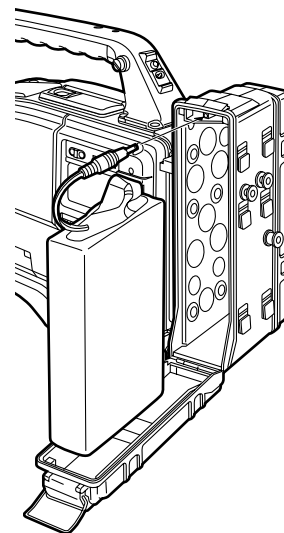

<Note>

Before connecting or disconnecting the plug, be absolutely sure to turn off the unit's power.

Power supply

Using the Sony NP-1/BP-90 battery pack

Attach the Sony battery holder. As shown in the figure, attach the battery case with the cover detached and then the detached cover.

- ① Tighten the mounting screws.
- ② Tighten the power contact screws.
- ③ Insert the top of the detached cover in the direction shown by the arrows.
- ④ Align the holes in the bottom of the cover (metal part) with the holes at the bottom of the case, and use the screws to attach the case.

<Note>

When mounting the battery holder, take care not to pinch the connecting cord.

Battery case for NP-1

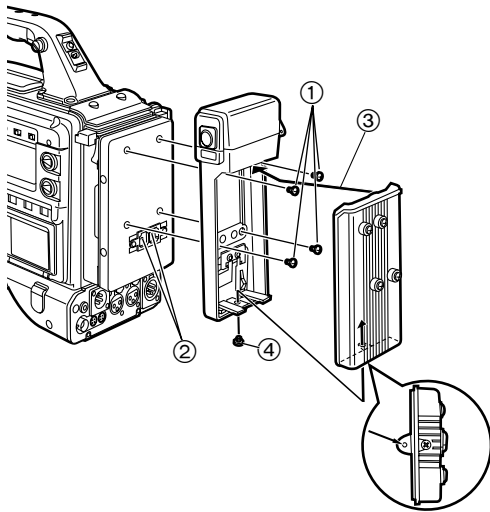

Battery case for BP-90

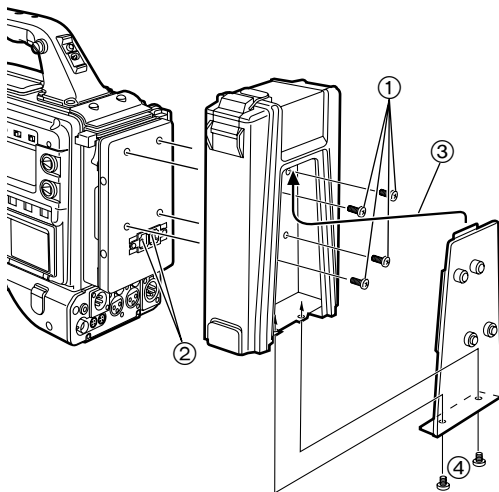

Using the V-mount type battery pack

Attach the V-mount adapter plate.

Insert it in the direction shown by the arrows, and slide it into place.

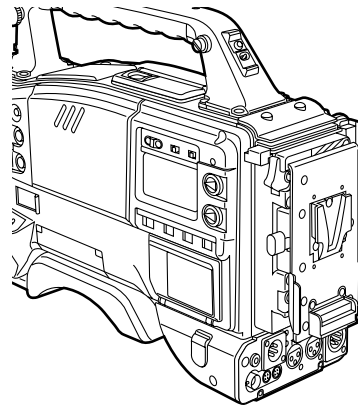
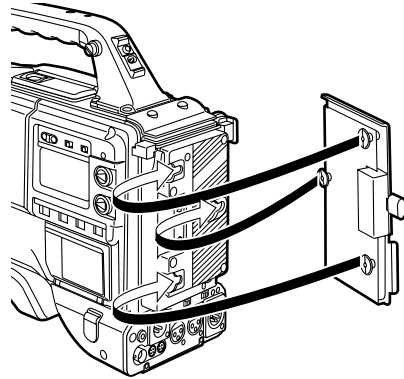

Please consult your local dealer for any questions regarding the NP/BP adapter plate or V-mount adapter plate.

Power supply

Using an AC power supply

When the AJ-B75 AC adapter is used

- 1 Connect the DC OUT connector on the AJ-B75 AC adapter to the DC IN socket on the unit.

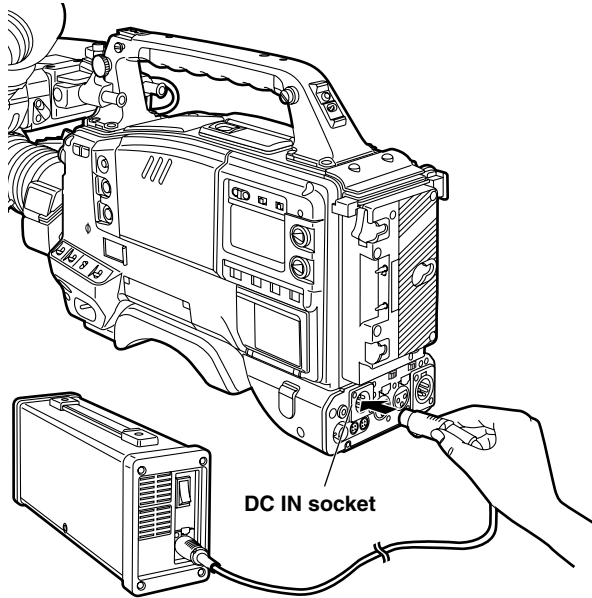

- 2 Set the power of the AC adapter to ON.

- 3 Set the unit's power switch to ON.

<Notes>

- Check the pin signals of the DC IN socket when using an external power supply other than the AJ-B75 AC adapter. (DC 12 V, 8.5 A)
- Power from the AC adapter takes precedence when both a battery pack and AC adapter have been connected.
- When using the AC adapter, be absolutely sure to first set the power of the AC adapter to ON and then set the unit's power switch to ON. If the power is turned on in the reverse sequence, the output voltage of the AC adapter will rise gradually, and the unit may malfunction as a result.

Pin no.	Signal
1	GND
2, 3	—
4	+12 V

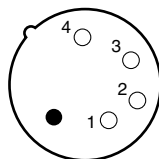

Attaching the lens

- 1** Raise the lever for securing the lens, and detach the mount cap.

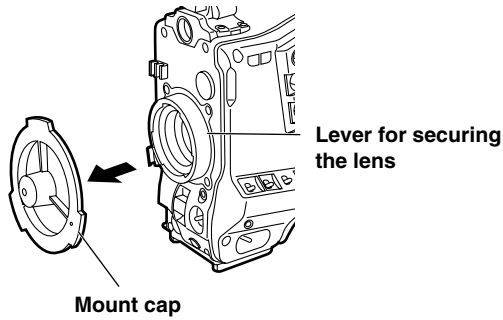

- 4** Push the cable into the cable clamp, and connect it to the LENS socket.

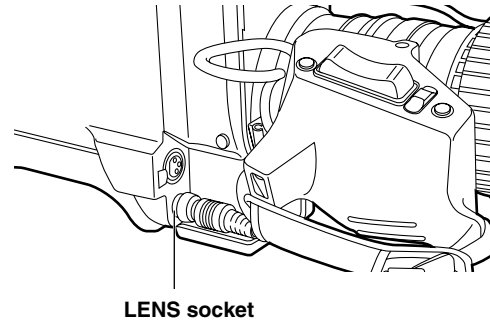

- 2** Align the centre mark of the lens with the groove in the top centre of the lens mount, and attach the lens.

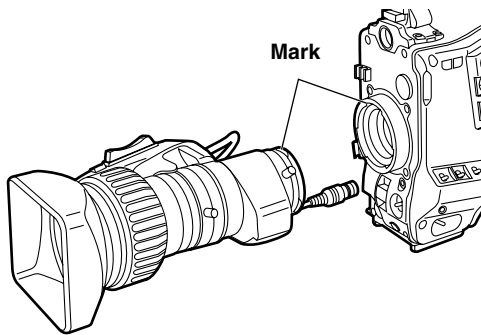

- 3** Push down the lever for securing the lens to secure the lens.

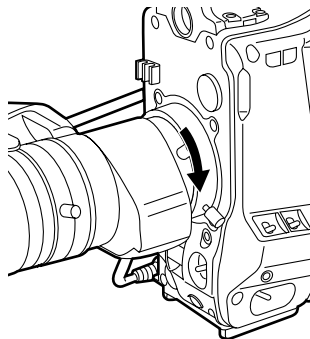

<Notes>

- For details on handling the lens, refer to the operating instructions which accompany the lens.
- The following lens adjustments and camera adjustments may be necessary depending on the lens mounted.
 1. Lens flange back adjustment
 2. Lens auto iris operating speed adjustment
 3. Lens white shading adjustment (performed on the unit)

Adjusting the lens flange

If the subject is not focused properly in the telephoto and wide-angle modes during zoom operations, adjust the flange back (distance from the lens mounting surface to the image-forming surface).

Once this adjustment is done, it need not be redone unless the lens is replaced.

Adjustment method

<Note>

For details on the adjustment method and lens positions, refer also to the operating instructions that accompany the lens.

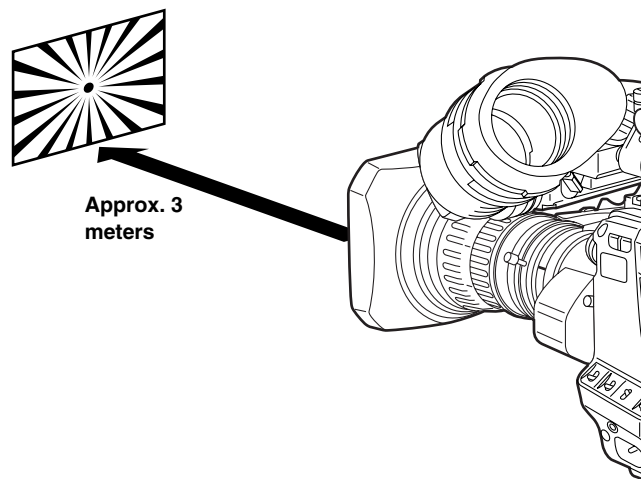

- 1** Attach the lens to the camera.
At this stage, do not forget to connect the lens cable.
- 2** Set the lens aperture to manual and open the aperture.
- 3** Set the lighting in such a way that the appropriate video output level is achieved at a distance of about 3 meters away from the chart used for the flange back adjustment.
If the video level is too high, use the filters and shutter.
- 4** Loosen the screw securing the F.f (flange focus) ring.
<Note>
On some lenses, this may be marked as F.b (flange back) ring.
- 5** Set the zoom ring to the telephoto position either manually or electrically.
- 6** Shoot the chart used for the flange back adjustment, and turn the distance ring to adjust the focus.
- 7** Set the zoom ring to the wide-angle position, and turn the F.f ring to adjust the focus.
Take care not to move the distance ring during this process.
- 8** Repeat steps **5** to **7** until the focus is adjusted at both the telephoto and wide-angle positions.
- 9** Tighten the screw securing the F.f ring.

Adjusting the white shading

This unit can store up to 8 white shading compensations as white shading files in memory. Using this data, it is possible to quickly reproduce the appropriate white shading adjustment even after switching lenses.

Follow the procedure described below when repeating a white shading adjustment or when creating a new white shading file.

White shading files

Storing of white shading adjustment values in memory for each lens changed and reading of data which has been stored are performed using the menus.

<Notes>

- The method below can be used for the white shading adjustments with most lenses. However, with some very special lenses, a different adjustment method may be necessary.
- Even when the white shading has been adjusted, tinting may occur in the vertical direction near the lens aperture open position. This is a phenomenon which is inherent to lenses and optical systems and is not indicative of malfunctioning.

Storing white shading adjustment values

- 1** Attach the lens to the camera.
At this stage, do not forget to connect the lens cable.
- 2** Set the electronic shutter to OFF, and set the gain to "L (0 dB)."

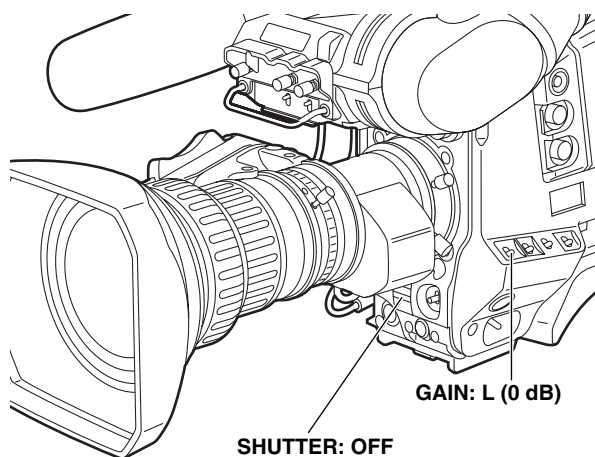

- 3** If the lens is provided with an extender, disengage the extender function.

- 4** Perform the menu operations (pages 86 to 88), and display the "VF DISPLAY" screen of FILM (CAM) MAIN MENU 2.

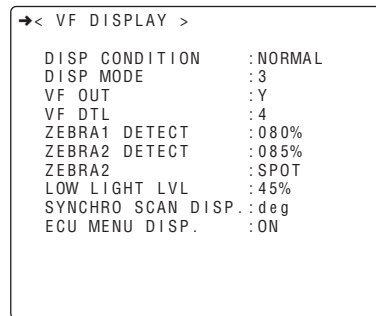

- 5** Turn the JOG dial button to move the arrow (cursor) to the ZEBRA1 DETECT item, and press the JOG dial button.
- 6** Turn the JOG dial button, select 70% and then press the JOG dial button to enter the setting.
- 7** Repeat steps 5 and 6, however this time set the ZEBRA2 DETECT to 85% and ZEBRA2 to SPOT.
- 8** Turn the JOG dial button to move the arrow (cursor) to the <VF DISPLAY> item, and press the JOG dial button.
- 9** Turn the JOG dial button to move the arrow (cursor) to the FILM (CAM) MAIN MENU 2 item.
- 10** Press the JOG dial button until FILM (CAM) MAIN MENU 4 is displayed, then turn the JOG dial button to move the arrow (cursor) to the WHITE SHADING item, and press the JOG dial button again.

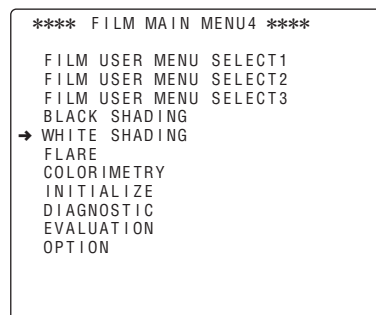

Adjusting the white shading

Select the file No.

11 Turn the JOG dial button to move the arrow (cursor) to the SELECT item

12 Press the JOG dial button and the file number will flash. Turn the JOG dial button to select the file (1 to 8) to be recorded.

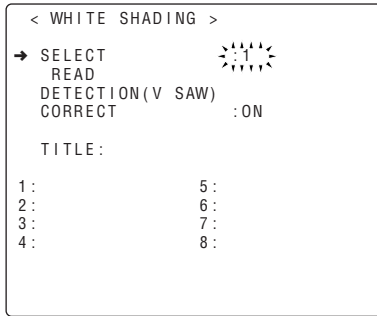

13 Press the JOG dial button to enter the file number.

Give a title to the selected file.

14 Turn the JOG dial button to move the arrow (cursor) to the "TITLE : " item.

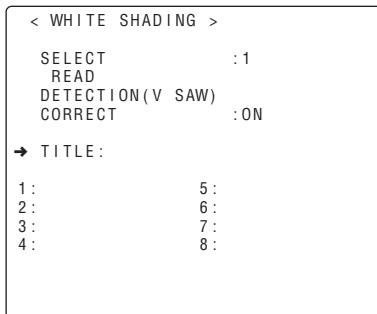

15 When the JOG dial button is pressed, the arrow (cursor) moves to the title input area, and the input mode is established.

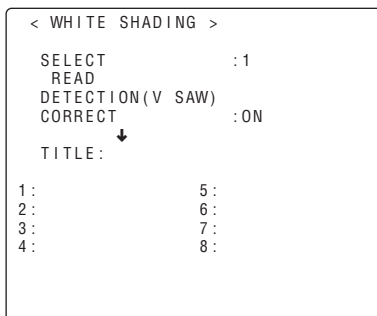

16 Press the JOG dial button again and turn it until the character to be set is displayed.

When the button is turned, the character displayed is switched in the following sequence:

- Space: □
- ↓
- letters: A—Z
- ↓
- numbers: 0—9
- ↓
- symbols: ', >, <, /, -, . , x

17 Press the JOG dial button to enter the character.

18 Turn the JOG dial button to move the arrow (cursor) to the next position (right), and repeat steps 16 and 17 to set the characters (maximum of 12).

19 When the title has been input, turn the JOG dial button to move the arrow (cursor) to the ":" position.

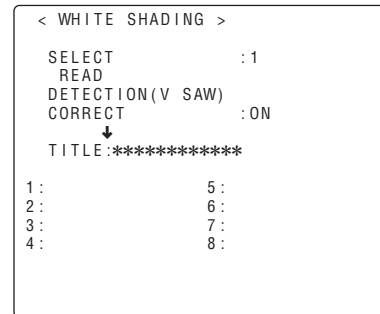

20 When the JOG dial button is pressed, the arrow (cursor) returns to the TITLE: item.

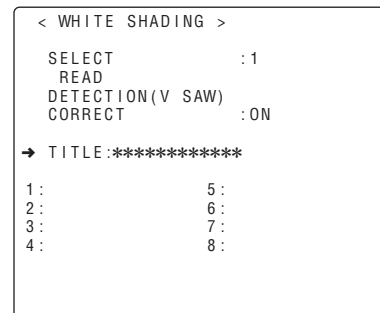

21 Press the MENU button twice to close the menu screen.

Adjusting the white shading

Performing white shading adjustments

22 Set the ZEBRA switch on the viewfinder to ON.

23 Shoot a sheet of white paper devoid of colour irregularities.

<Note>

Since flicker tends to occur under fluorescent lights, mercury lamps and other such lights, use a source of light such as sunlight or a halogen lamp which does not tend to produce flicker.

24 Set the lens aperture to manual, and adjust the lens aperture in such a way that ZEBRA fills the whole screen.

Check that the lens aperture is between F/4 and F/11.

<Notes>

- Since unevenness in the lighting will make it impossible for ZEBRA to fill part of the screen, try adjusting the lighting position, etc.
- Try adjusting the lighting position, etc. also when the lens aperture is not between F/4 and F/11.
- Always be sure to leave the electronic shutter at OFF.

- 25** ① Set the WHITE BAL selector switch to “A” or “B,” and initiate the automatic white balance (AWB) adjustment using the AUTO W/B BAL switch.
- ② Initiate the automatic black balance (ABB) adjustment using the AUTO W/B BAL switch.
- ③ Initiate the automatic white balance (AWB) adjustment again using the AUTO W/B BAL switch.

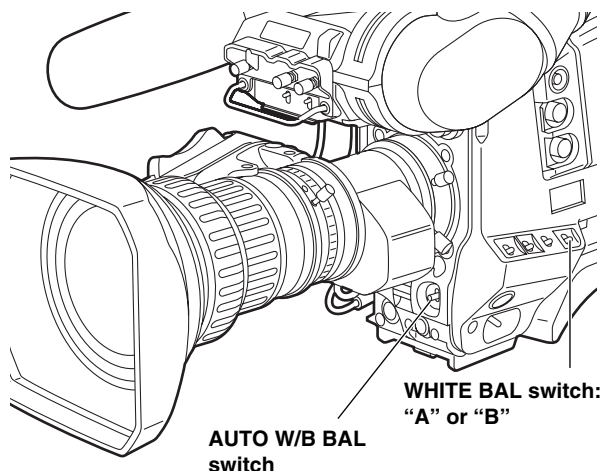

26 Repeat step 24.

27 Perform the menu operations (pages 86 to 88), and display the “WHITE SHADING” screen of FILM (CAM) MAIN MENU 4.

28 Turn the JOG dial button to move the arrow (cursor) to the DETECTION (V SAW) item.

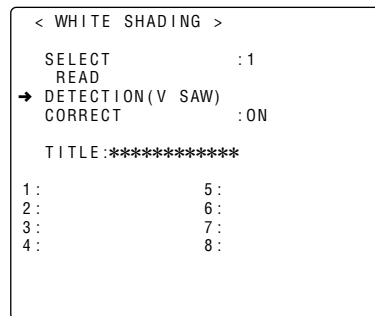

29 When the JOG dial button is pressed, the following message appears.

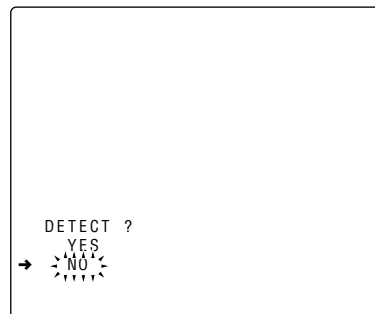

30 Turn the JOG dial button to move the arrow (cursor) to YES, and press the JOG dial button. “ACTIVE” appears on the screen to indicate that automatic adjustment of white shading is being performed. “END” appears on the screen upon completion of the adjustment.

31 Press the MENU button twice upon completion of the adjustment. The setting menu is cleared, and the displays showing the unit’s current statuses appear at the top and bottom of the viewfinder screen.

Adjusting the white shading

32 If the lens is provided with an extender, engage the extender function, and repeat steps **24** to **31**.

The compensation values for when the lens extender function is provided and for when it is not are both stored in one file in memory.

The white shading adjustment is now complete. The adjusted values are retained in the non-volatile memory so that there is no need to adjust the white shading again even after the unit's power is turned off.

Reading white shading files

1 Perform the menu operations (pages 86 to 88), and display the "WHITE SHADING" screen of FILM (CAM) MAIN MENU 4.

```
→ < WHITE SHADING >
SELECT                : 1
READ
DETECTION(V SAW)
CORRECT               : ON
TITLE:
1:                    5:
2:                    6:
3:                    7:
4:                    8:
```

2 Turn the JOG dial button to move the arrow (cursor) to the SELECT item

3 Press the JOG dial button and the file number will flash. Turn the JOG dial button to select the file (1 to 8) to be read.

```
< WHITE SHADING >
→ SELECT                1
READ
DETECTION(V SAW)
CORRECT               : ON
TITLE:
1:                    5:
2:                    6:
3:                    7:
4:                    8:
```

4 Press the JOG dial button to enter the file number.

5 Turn the JOG dial button to move the arrow (cursor) to the READ item

```
< WHITE SHADING >
SELECT                : 1
→ READ
DETECTION(V SAW)
CORRECT               : ON
TITLE:
1:                    5:
2:                    6:
3:                    7:
4:                    8:
```

6 When the JOG dial button is pressed, the following message appears.

```
READ ?
  YES
→ NO
```

7 Turn the JOG dial button to move the arrow (cursor) to YES, and press the JOG dial button. The recorded data from the white shading file is read.

8 Press the MENU button twice. The setting menu is cleared, and the displays showing the unit's current statuses appear at the top and bottom of the viewfinder screen.

Adjusting the viewfinder (The viewfinder is an optional accessory.)

Attaching the viewfinder

1 Check that the camera's POWER switch is at OFF.

2 Connect the plug to the viewfinder connecting terminal.

<Note>

When connecting the plug to the viewfinder connecting terminal, push the plug firmly into place.

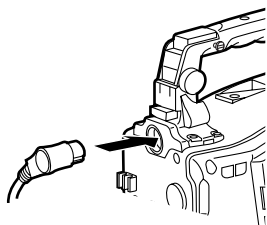

3 Push the viewfinder down.

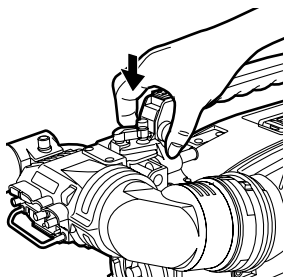

4 Tighten the stopper screw firmly.

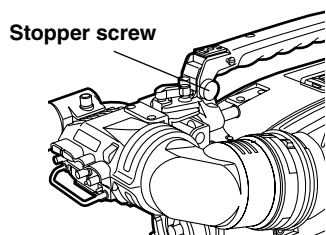

Detaching the viewfinder

1 Check that the camera's POWER switch is at OFF.

2 Loosen the stopper screw, pull the viewfinder straight up, and draw it out.

<Note>

Use both hands to draw the viewfinder out. It may not be possible to remove the viewfinder smoothly with one hand, which may cause damage to it.

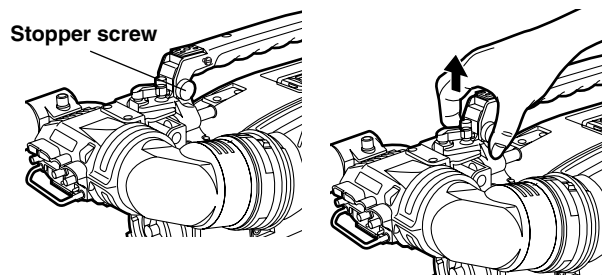

3 Disconnect the plug from the viewfinder connecting terminal.

Adjusting the viewfinder (The viewfinder is an optional accessory.)

Adjusting the viewfinder position

- 1** Pull up the lever for securing the viewfinder in the back/front and sideways directions to disengage the lock.

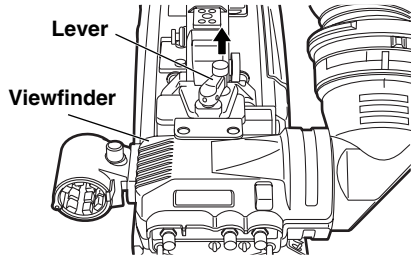

- 2** Loosen the lever for securing the viewfinder in the back/front and sideways directions.

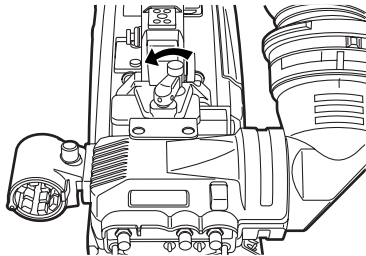

- 3** Move the viewfinder in the back/front and sideways directions, and adjust its position.

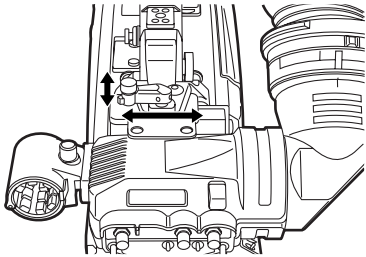

- 4** Tighten the lever for securing the viewfinder in the back/front and sideways directions until it locks the viewfinder in place.

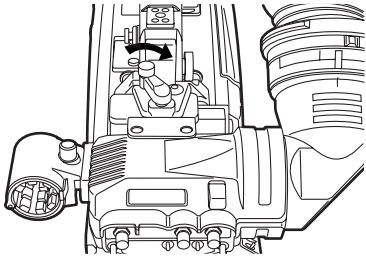

Audio input preparation

When attaching a microphone to the viewfinder (optional accessory) for use

The microphone of the AJ-MC700P mic kit (optional accessory) can be attached to the viewfinder.

1 Open the mic holder.

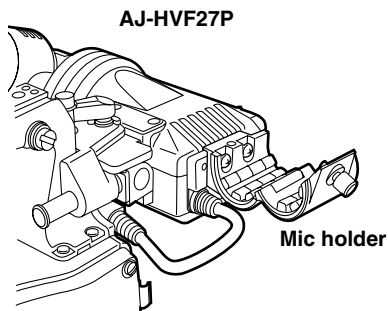

2 Attach the microphone, and tighten the locking screw.

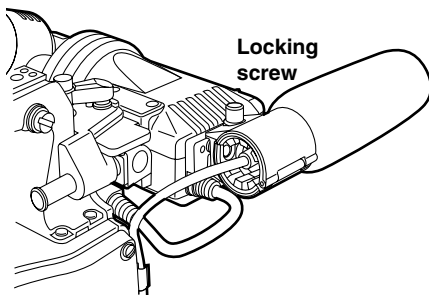

3 Connect the microphone's connecting cable to the MIC IN jack on the camera.

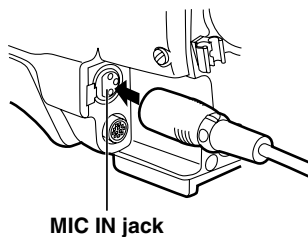

4 Set the AUDIO IN switch or switches to "FRONT" in accordance with the audio channel or channels whose sound is to be recorded.

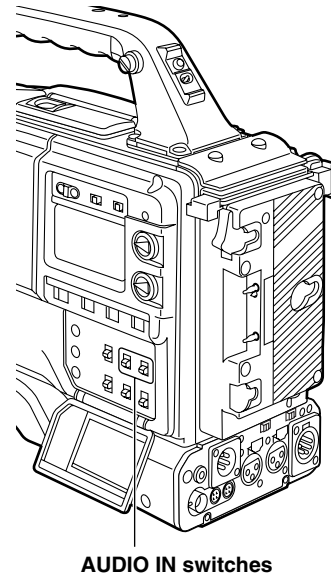

Audio input preparation

When attaching a microphone to the main unit for use

Attaching the AJ-MH700P mic holder (optional accessory)

1 Remove the screws used to attach the mic holder.

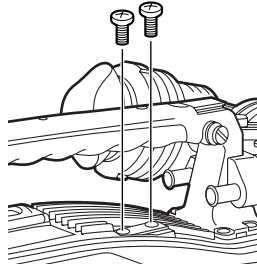

4 Connect the microphone's connecting cable to the MIC IN jack on the camera.

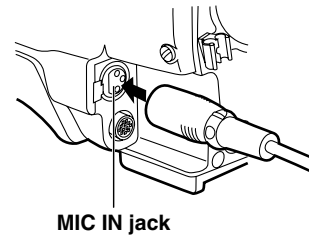

2 Attach the mic holder to the main unit using the screws provided with the AJ-MH700P mic holder.

Screws provided with mic holder

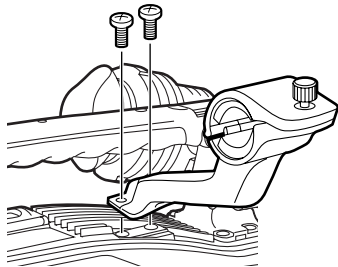

5 Set the AUDIO IN switch or switches to "FRONT" in accordance with the audio channel or channels whose sound is to be recorded.

3 Attach the microphone to the mic holder, and tighten the locking screw.

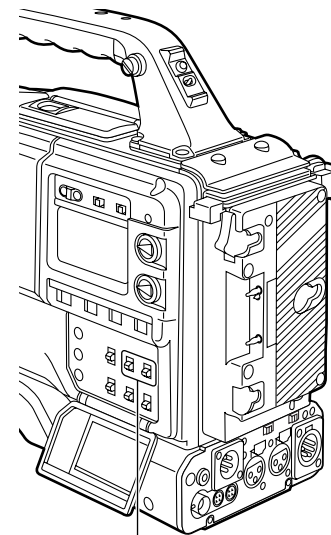
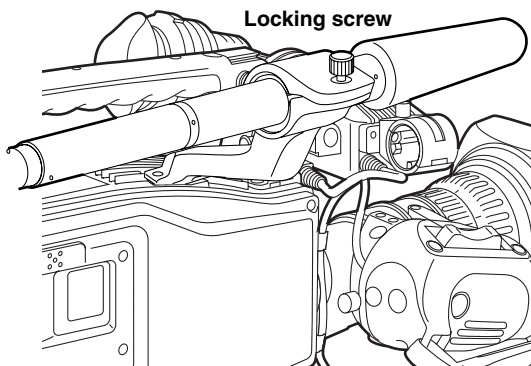

Audio input preparation

When connecting a microphone to the MIC IN jack

- 1 Connect the microphone's connecting cable to the MIC IN jack on the camera.

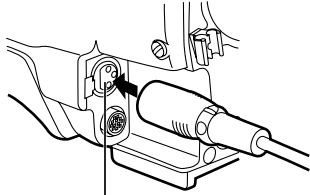

MIC IN jack

- 2 Set the AUDIO IN switch or switches to "FRONT" in accordance with the audio channel or channels whose sound is to be recorded.

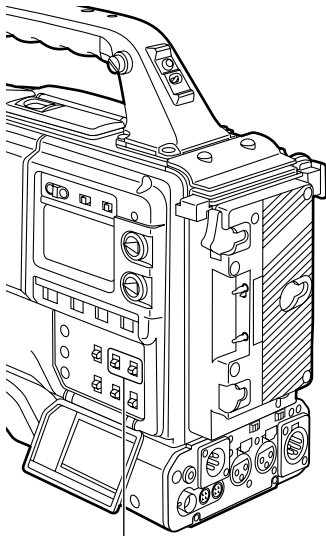

AUDIO IN switches

<Note>

When extending the microphone's connecting cable, use a cable which supports the phantom power supply system.

When connecting a microphone to the AUDIO IN connector

- 1 Connect the microphone's connecting cable to the AUDIO IN connector on the camera. Two microphones can be connected to the CH1 and CH2 connectors.

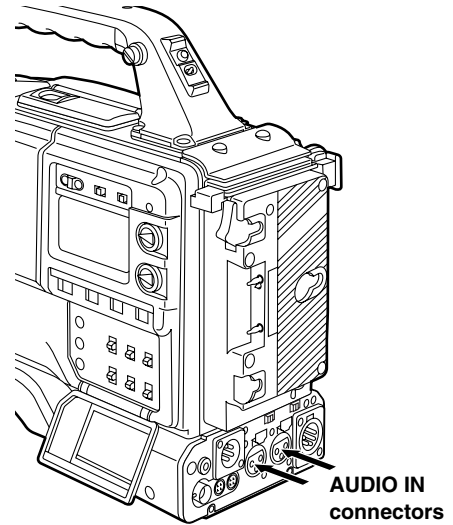

AUDIO IN connectors

- 2 Set the AUDIO IN switch or switches for the channel or channels to which the microphone or microphones have been connected to "REAR."

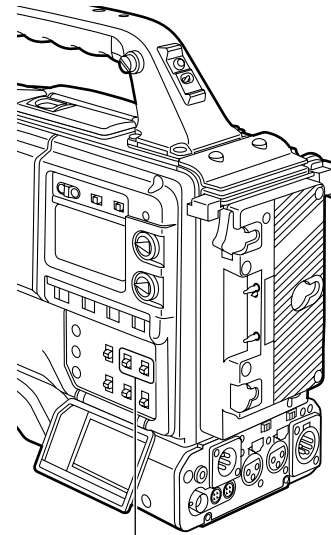

AUDIO IN switches

<Note>

When the LINE/MIC/+48V selector switch is set to "+48V," the phantom power supply system is supported.

Audio input preparation

When using a wireless microphone

Attach the WX-RJ700 wireless receiver when Panasonic's wireless system is to be used.

- 1 Attach the WX-RJ700 wireless receiver to the WX-ZJ770 camera attachment.
- 2 Align the grooves in the camera attachment with the pins on the battery case, etc. to attach the wireless receiver.

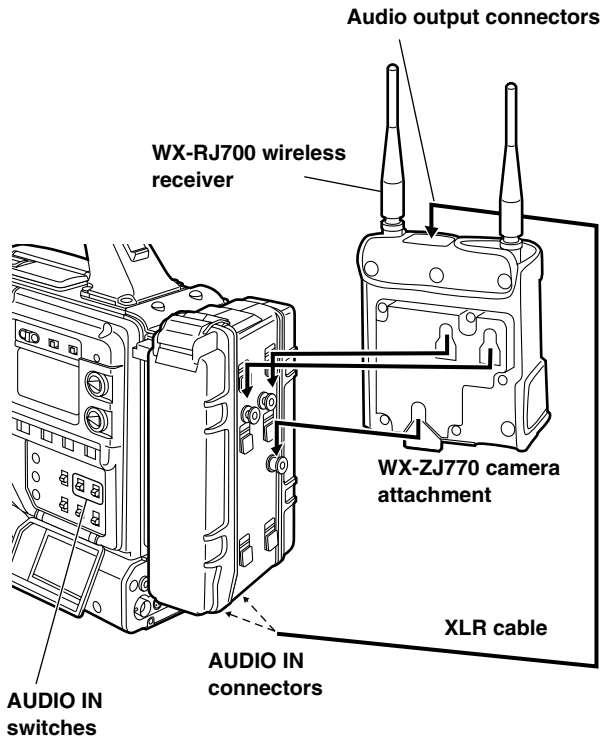

- 3 Connect the AUDIO IN connectors on the camera with the wireless receiver using the XLR cable.
- 4 Set the AUDIO IN switch or switches for the channel or channels to which the XLR cable has been connected to "REAR."
- 5 Set the LINE/MIC/+48V selector switch on the rear panel to "MIC."

When detaching the wireless receiver, push up the lever on the bottom panel of the camera attachment to disengage it.

<Note>

For details on the operations and other aspects of the WX-RJ700 wireless receiver, refer to the operating instructions which accompany the receiver.

When connecting audio components

- 1 Connect the AUDIO IN connectors on the camera with the audio component using the XLR cable.

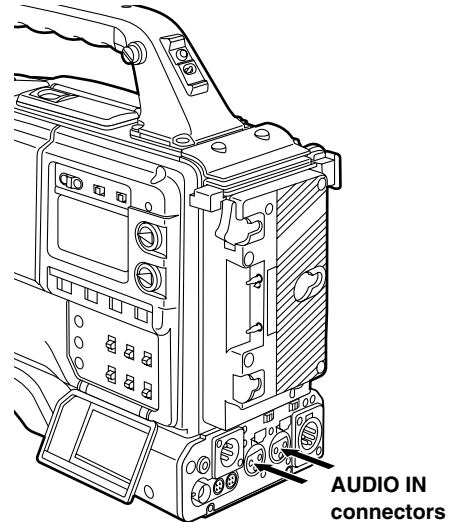

- 2 Set the AUDIO IN switch or switches for the channel or channels to which the audio component has been connected to "REAR."
- 3 Set the LINE/MIC/+48V selector switch on the rear panel to "LINE."

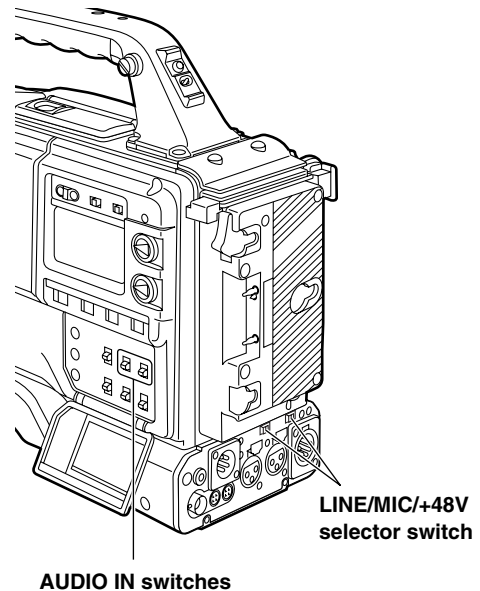

Mounting the unit on a tripod

Use the tripod attachment available as an optional accessory for mounting the unit onto a tripod.

1 Attach the tripod attachment to the tripod.

<Note>

Select the attachment holes that best support the centre of gravity of the unit and tripod attachment. Check that the diameters of the selected holes match the diameters of the pan head.

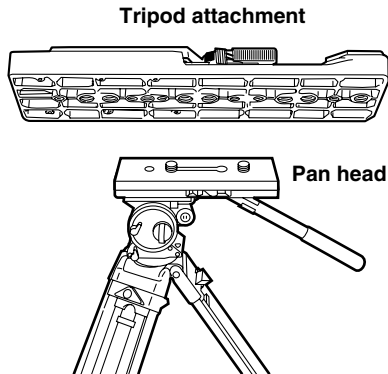

2 Attach the camera to the tripod attachment. Slide the camera toward the front along the grooves until it clicks into place.

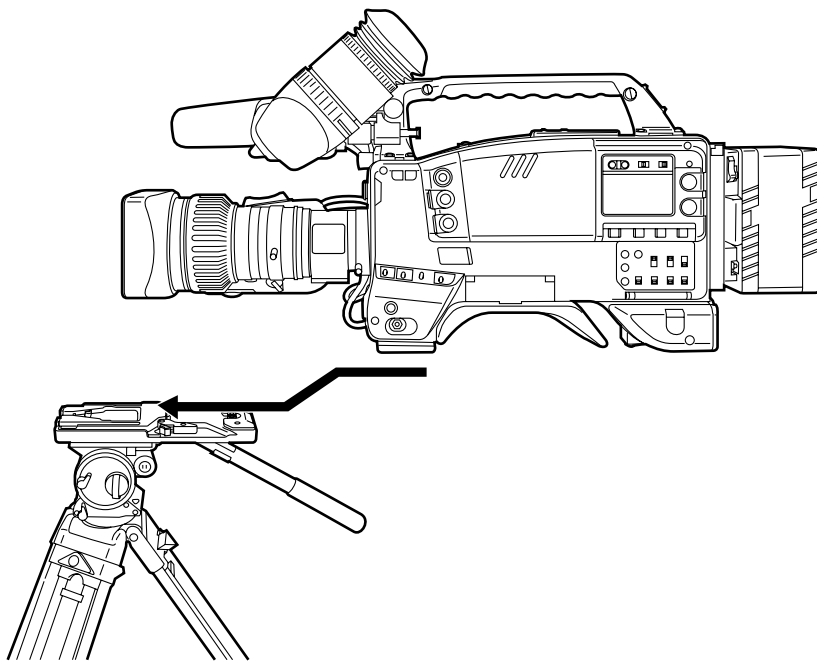

Detaching the unit from the tripod attachment

While pressing the red lever, move the black lever in the direction of the arrow, slide the unit toward the rear, and detach it.

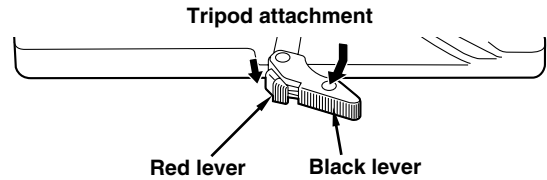

<Note>

If the pins in the tripod attachment fail to return to their original positions after the camera has been detached, press the red lever again and at the same time move the black lever in the direction of the arrow: this will return the pins to their original positions.

Bear in mind that the camera cannot be attached while the pins are left in the centre.

Attaching the shoulder strap

- 1 Attach the shoulder strap to the shoulder strap mounting hooks, and adjust the length of the strap.

<Note>

Check that the shoulder strap is securely fastened.

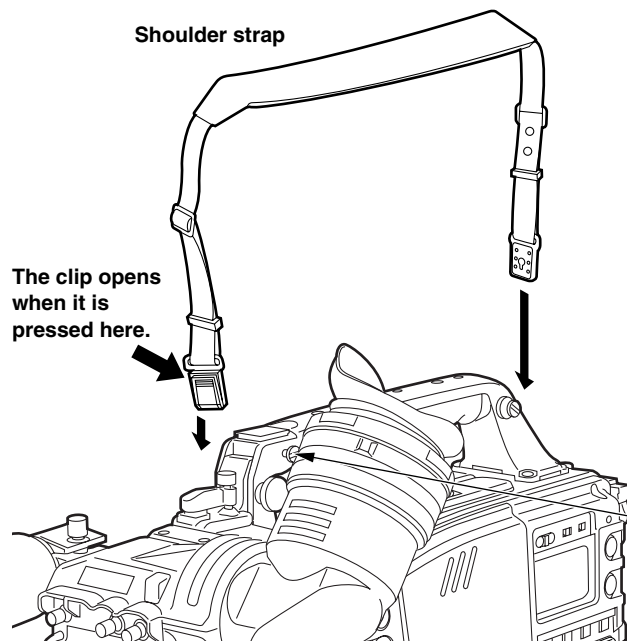

To detach the shoulder strap, open the clips on the mounting parts and detach.

The clip opens when it is pressed here.



<Note>

This mounting hook is for attaching the tape measure that is used to measure the subject distance. It is not to be used for the shoulder strap.

Adjusting the shoulder pad position

The shoulder pad can be slid up to 15 mm either backward or forward from the centre position (factory setting).

Adjust the pad's position to operate the unit with the optimum ease.

- 1 Loosen the two screws.
- 2 Slide the shoulder pad either backward or forward, and find the optimum position.
- 3 Tighten the screws to secure the shoulder pad.

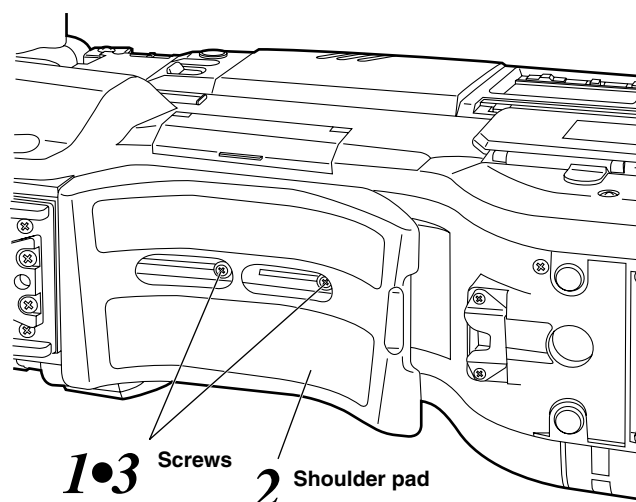

Bottom section

Attaching the rain cover

Example showing use of the SHAN-RC700 rain cover

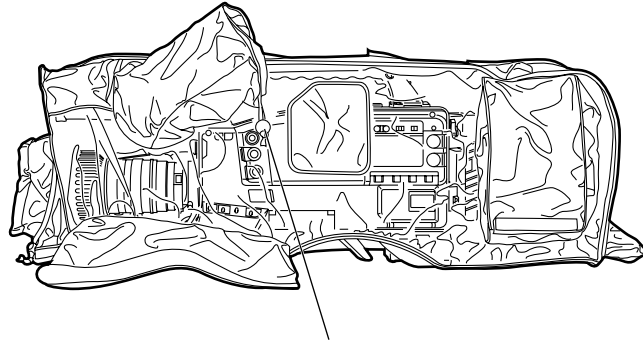

Tighten the cord.

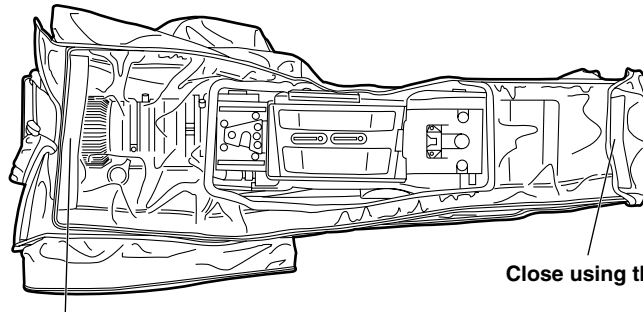

Close using the fastener.

Close using the fastener.

Connecting the extension control unit

By connecting the AJ-EC3 extension control unit (optional accessory), some of the functions can be operated by remote control.

When the AJ-EC3 is connected and the POWER switches on the unit and AJ-EC3 are set to ON, the unit is automatically set to the remote control mode.

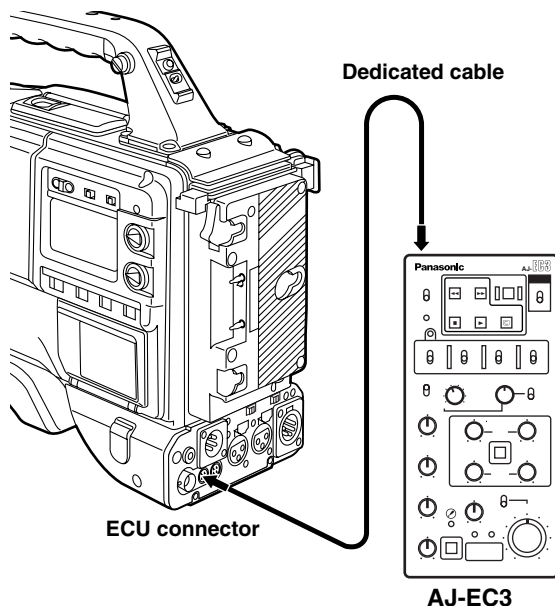

<Notes>

- Before connecting or disconnecting the dedicated cable, be absolutely sure to set the POWER switches on the unit and AJ-EC3 to OFF.
- When "OFF" has been selected as the ECU DATA SAVE setting on the CAMERA SW MODE screen of FILM (CAM) MAIN MENU 2, all the adjustments and settings made using the AJ-EC3 will be cleared when the unit's power switch is set to OFF. Neither is it possible to save these adjustments and settings on a setup card. However, the menu item settings can be saved on a setup card. When the AJ-EC3 is connected again, its settings will be restored.
- When "ON" has been selected as the ECU DATA SAVE setting on the CAMERA SW MODE screen of FILM (CAM) MAIN MENU 2, all the adjustments and settings made using the AJ-EC3 will not be cleared even when the unit's power switch is set to OFF.

Viewfinder lamp displays

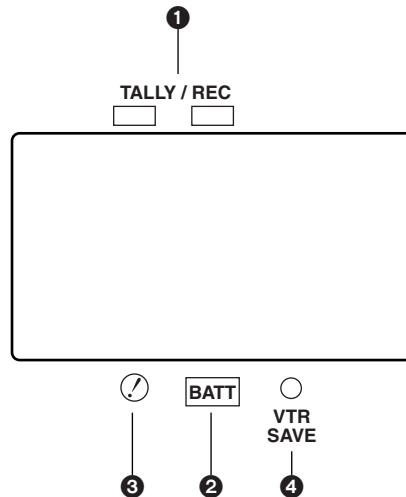

Viewfinder pictured here is the AJ-HVF27P
(For details concerning the viewfinder, refer to
the operating instructions of the viewfinder.)

① TALLY/REC (recording) lamp

This lights up (red) during recording. It flashes when a problem has occurred.

For details, refer to the section on the “Warning system” (pages 124, 125).

② BATT (battery) lamp

This starts flashing when the battery voltage has dropped to the level where the battery will no longer be usable in several minutes’ time, and it lights when the battery is no longer usable. To prevent operation from being interrupted, replace the battery before the battery has discharged completely.

For details, refer to the section on the “Warning system” (pages 124, 125).

③ ⚠ (abnormal operating status warning) lamp

This lights when the unit is set to an abnormal operating status for any of the items set to “ON” on the “!LED” screen of the setting menu.

For details on selecting the items targeted for the ⚠ lamp display, refer to the section on “Setting the ⚠ lamp displays” (next page).

④ VTR SAVE (VTR power-saving) lamp

This lights when the VTR SAVE/STBY switch is set to SAVE. It goes off during recording.

<Note>

In the rec pause mode, the SAVE mode is established automatically, and the lamp lights after the time set for the pause timer (temporary stop time) has elapsed.

After two minutes in the play pause mode, the SAVE mode is established automatically, and the lamp lights.

Viewfinder lamp displays

Setting the lamp displays

Select the items targeted for the  lamp display on the “!LED” screen of the FILM (CAM) MAIN MENU 2 screen. (Under the factory settings, the “!LED” screen is not displayed.)

To perform operations on the “!LED” screen, either switch the unit to the engineer mode menu or select the “!LED” screen on the FILM (CAM) USER MENU SELECT 2 screen under the FILM (CAM) MAIN MENU 4 screen.

<Note>

For details on selecting the engineer mode menu and display screens, refer to “Menu operations” (pages 86 to 88).

1 Perform the menu operations (pages 86 to 88) to open the “!LED” screen.

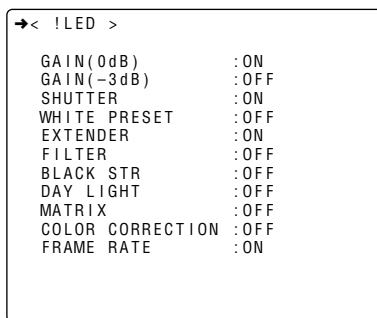

2 Turn the JOG dial button to move the arrow (cursor) to the desired item.

3 For the selected item, press the JOG dial button, and set whether or not the item is to be displayed on the viewfinder screen.

Turn the JOG dial button, select display (ON) or no display (OFF) and press the JOG dial button to enter the selection.

4 Repeat steps 2 and 3 to set ON or OFF for the other items.

5 Press the MENU button to exit the menu operations.

The setting menu is cleared, and the displays showing the unit’s current statuses appear at the top and bottom of the viewfinder screen.

Setting item	Description of setting
GAIN (0 dB)	Lamp display appears when the gain is set to a value other than “0 dB.”
GAIN (-3 dB)	Lamp display appears when the gain is set to a value other than “-3 dB.”
SHUTTER	Lamp display appears when the SHUTTER switch is at ON.
WHITE PRESET	Lamp display appears when “PRST” applies to the channel in the white balance memory.
EXTENDER	Lamp display appears when the lens extender is used.
FILTER	Lamp display appears when the filter is set to a value other than “3200 K.”
BLACK STR	Lamp display appears when the black stretch is at ON.
DAY LIGHT (FILM MENU)	Lamp display appears when the white balance presetting is DAY LIGHT.
D5600K (CAM MENU)	Lamp display appears when the white balance presetting is 5600 K.
MATRIX	Lamp display appears when the matrix is at ON.
COLOR CORRECTION	Lamp display appears when the colour correction is at ON.
FRAME RATE	Lamp display appears when the frame rate has been set to 11 fps or below.

Viewfinder screen status displays

In addition to the pictures shot, the unit's settings and messages indicating its operating statuses are displayed on the viewfinder screen. The centre marker and safety zone markers also appear.

The items which have been set to ON by the switches relating to the viewfinder displays or the VF DISPLAY screen of the setting menu are displayed at the top and bottom of the screen.

When settings have been changed or adjustments have been made, messages advising the user of what has been set, what progress has been made in the adjustments and what the adjustment results are can be displayed for about 3 seconds.

■ Display items and where they are displayed

- ① Extender display
- ② Shutter speed/mode display
- ③ Remaining tape display
- ④ Battery voltage display
- ⑤ Filter display
- ⑥ White balance memory display
- ⑦ Gain display
- ⑧ Audio level display
- ⑨ Aperture display
- ⑩ Camera warning/information display
- ⑪ Safety zone markers
- ⑫ Centre marker
- ⑬ Super iris ON display
- ⑭ Zoom position display
- ⑮ TCG display
- ⑯ Master gain setting display
- ⑰ Colour temperature display PRE/A/B
- ⑱ Battery type
- ⑲ Total tape length
- ⑳ Preset colour temperature display
- ㉑ VTR warning/information display
- ㉒ Interval recording mode display (flashing)
- ㉓ AUDIO CH1/CH2 input display
- ㉔ Frame rate information display
- ㉕ ⌚ lamp information display
- ㉖ Frame frequency information display
- ㉗ Operation mode display

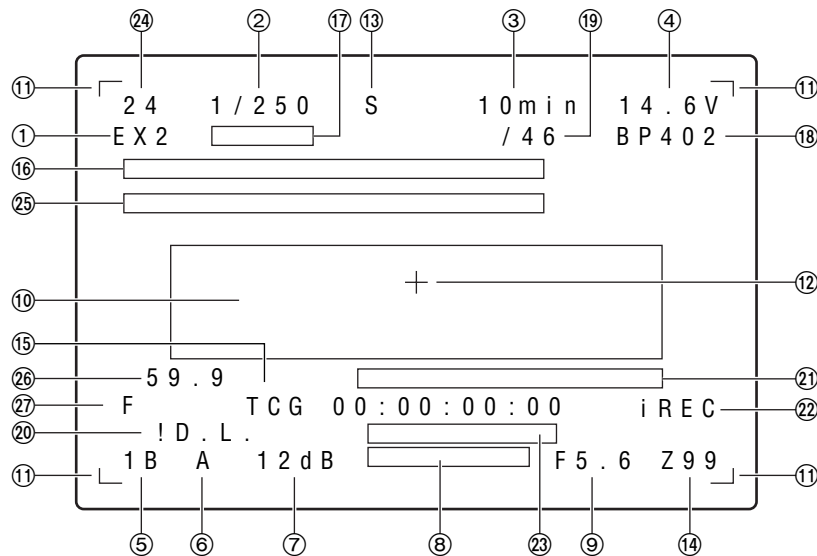

Viewfinder screen status displays

① Extender display

This appears when the lens extender is being used.

② Shutter speed/mode display

This indicates the shutter speed or shutter mode setting.

The unit in which the shutter speed is displayed can be set on the VF DISPLAY screen of FILM (CAM) MAIN MENU 2.

- **OFF (no display):**

The shutter is not used.

- **1/100, 1/120, 1/250 1/500, 1/1000, 1/2000 (180d, 172.8d, 144d, 120d, 90d, 45d):**

Shutter speeds in the fixed mode

- **3.0d to 350.0d/0.8% to 97.2% (SYNCHRO SCAN):**

Selection of synchro scan mode

In the synchro scan mode, “▶” appears immediately in front of the number displayed.

③ Remaining tape display

During recording, this shows the remaining tape (in minutes) in the VTR. When less than two minutes of tape remain, the figure starts flashing.

④ Battery voltage display

This indicates the battery voltage (V) during operation. The voltage is displayed as a percentage when a digital battery is used.

⑤ Filter display

This indicates the type of filter selected.

⑥ White balance memory display

This indicates the automatic adjustment memory selected for the white balance.

A: The WHITE BAL switch has been set to “A.”

B: The WHITE BAL switch has been set to “B.”

P: The WHITE BAL switch has been set to “PRST.”

⑦ Gain display

This indicates the gain (dB) of the video amplifier which was set using the GAIN switch.

⑧ Audio level display

This indicates the audio level (which can be displayed separately for audio CH1 and CH2).

During sine wave input, it roughly corresponds with the VTR's level meter as shown below.

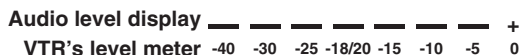
Audio level display 

⑨ Aperture display

This indicates the approximate aperture setting (F number).

<Note>

This appears when a lens with an aperture display function is being used.

⑩ Camera warning/information display

The black balance, white balance, auto knee function, super iris, super gain and other alarm displays and warnings appear here.

⑪ Safety zone markers

These indicate the 80% or 90% (factory setting) range of the surface area of the viewfinder screen.

The display range proportion is set on the VF DISPLAY screen of the setting menu.

For details, refer to “Setting the marker displays” (page 49).

⑫ Centre marker

This indicates the centre of the viewfinder screen. The display is set ON or OFF on the VF DISPLAY screen of the setting menu.

⑬ Super iris ON display

“S” appears when the super iris is ON.

⑭ Zoom position display

The distance from the WIDE end to TEL end of the zoom lens is indicated here as a number from 0 to 99.

⑮ TCG display

This indicates the time code generator value.

⑯ Master gain setting display

The GAIN L/M/H values currently set appear here when the MODE CHECK button is pressed.

⑰ Colour temperature display PRE/A/B

This indicates the colour temperature when AWB is executed using white balance memory A or B.

Viewfinder screen status displays

18 Battery type

This indicates the type of battery selected.

19 Total tape length

This indicates the total length of the cassette tape.

20 Preset colour temperature display

This indicates the preset white balance value.

21 VTR warning/information display

Alarm displays such as SLACK, REC WARNING, HUMID, SERVO and RF as well as other warnings are indicated here.

22 Interval recording mode display (flashing)

23 AUDIO CH1/CH2 input display

The input signals to be recorded in audio channels 1 and 2 are indicated here.

24 Frame rate information display

This indicates the frame rate which has been set.

25 lamp information display

This indicates the information when the  lamp has lit.

26 Frame frequency information display

This indicates the frame frequency (59.94 Hz or 60.00 Hz) which has been set.

27 Operation mode display

This indicates the unit's operation mode (F: FILM or V: VIDEO) which has been set.

Selecting the display items

The items to be displayed on the viewfinder screen can each be set to ON or OFF on the "VF INDICATOR" screen of the FILM (CAM) MAIN MENU 2 or on the "VTR VF INDICATOR" screen of the VTR MENU.

Selectable items

On the "VF INDICATOR" screen of FILM (CAM) MENU

- Extender display (EXTENDER)
- Shutter speed/mode display (SHUTTER)
- Filter display (FILTER)
- White balance memory display (WHITE)
- Gain display (GAIN)
- Aperture value and super iris ON display (IRIS)
- Camera ID display (CAMERA ID)
- Zoom position display (ZOOM LVL)
- Colour temperature display (COLOR TEMP)
- Frame rate display (FRAME RATE)
- Gamma curve display (VERSION ID)

<Note>

The camera ID appears when colour bar signals are to be recorded in accordance with the OUTPUT/AUTO KNEE switch setting.

For details, refer to "Setting the camera ID" (page 50).

-< VF INDICATOR >	
EXTENDER	: ON
SHUTTER	: ON
FILTER	: ON
WHITE	: ON
GAIN	: ON
IRIS	: S+IRIS
CAMERA ID	: ON
ZOOM LVL	: OFF
COLOR TEMP	: ON
FRAME RATE	: ON
VERSION ID	: ON

Viewfinder screen status displays

On the “VTR VF INDICATOR” screen of VTR MENU

- Remaining tape display (TAPE)
- Remaining battery charge display (BATTERY)
- Level meter display (LEVEL METER)
- Time code display (TC)
- VTR warning display (VTR WARNING)
- SAVE lamp display (SAVE LED)

```
→< VTR VF INDICATOR >
TAPE(IND)      :ON
BATTERY(IND)   :ON
LEVEL METER(IND) :CH1
AUDIO IN(IND)  :OFF
TC(IND)        :OFF
VTR WARNING(IND) :NORMAL
SAVE LED       :SAVE
```

Selecting the display items

- 1 Perform the menu operations (pages 86 to 88) to open the “VF INDICATOR” screen.

```
→< VF INDICATOR >
EXTENDER      :ON
SHUTTER       :ON
FILTER        :ON
WHITE         :ON
GAIN          :ON
IRIS          :S+IRIS
CAMERA ID     :ON
ZOOM LVL     :OFF
COLOR TEMP    :ON
FRAME RATE    :ON
VERSION ID    :ON
```

```
→< VTR VF INDICATOR >
TAPE(IND)      :ON
BATTERY(IND)   :ON
LEVEL METER(IND) :CH1
AUDIO IN(IND)  :OFF
TC(IND)        :OFF
VTR WARNING(IND) :NORMAL
SAVE LED       :SAVE
```

- 2 Turn the JOG dial button to move the arrow (cursor) to the desired item.

- 3 For the selected item, press the JOG dial button, and set whether or not the item is to be displayed on the viewfinder screen.
Turn the JOG dial button to select display (ON) or no display (OFF), and press the JOG dial button to enter the selection.

- 4 Repeat steps 2 and 3 to set ON or OFF for other items.

- 5 Press the MENU button to exit the menu operations.
The setting menu is cleared, and the displays showing the unit’s current statuses appear at the top and bottom of the viewfinder screen.

Viewfinder screen status displays

Display modes and setting change messages

The display of messages advising the user of what changes have been made to the settings and what the adjustment results are can be turned off for some or all of the items displayed.

Setting change/adjustment result messages and display modes

Situation in which message is displayed	Message	Display mode setting		
		1	2	3
When the filter selection has been changed	Filter: n (n=1, 2, 3, 4), m (m=A, B, C, D)	×	×	○
When the gain setting has been changed	GAIN: n dB (n= -6, -3, 0, 3, 6, 9, 12, 18, 24, 30)	×	×	○
When the WHITE BAL switch setting has been changed	WHITE: n (n=ACH, BCH, PRESET)	×	×	○
When the OUTPUT/AUTO KNEE switch has been set to AUTO KNEE or OFF <Note> This display is shown for about 3 seconds immediately after the unit's power has been switched on.	AUTO KNEE: ON (or OFF)	×	○	○
When the shutter speed/mode setting has been changed	SS: 1/100 (or 1/120, 1/250, 1/500, 1/1000, 1/2000, S.SCAN, 3.0d to 350.0d, 0.8% to 97.2%)	×	○	○
When the white balance (AWB) has been adjusted	Example) AWB: OK For details, refer to "Adjusting the white balance" (pages 53 to 56).	×	○	○
When the black balance (ABB) has been adjusted	Example) ABB: OK For details, refer to "Adjusting the black balance" (page 57).	×	○	○

<Note>

The message displays also depend on the status of other menu settings. For instance, even when "1 (no display)" is set as the filter selection, the filter selection will be displayed when FILTER is set to "ON" on the VF INDICATOR screen.

○ : Message is to be displayed.

×

Message is not to be displayed.

Viewfinder screen status displays

Switching the display mode

The display mode settings are switched on the VF DISPLAY screen.

- 1 Perform the menu operations (pages 86 to 88) to open the “VF DISPLAY” screen of FILM (CAM) MAIN MENU 2.

```
→< VF DISPLAY >
DISP CONDITION :NORMAL
DISP MODE      :3
VF OUT         :Y
VF DTL         :4
ZEBRA1 DETECT :080%
ZEBRA2 DETECT :085%
ZEBRA2         :SPOT
LOW LIGHT LVL :45%
SYNCHRO SCAN DISP.:deg
ECU MENU DISP. :ON
```

- 2 Turn the JOG dial button to move the arrow (cursor) to the “DISP MODE” item.

- 3 Press the JOG dial button, and set the desired display mode.
Turn the JOG dial button to select the display contents, and press the JOG dial button to enter the selection.

- 4 Press the MENU button to exit the menu operations.
The setting menu is cleared, and the displays showing the unit’s current statuses appear at the top and bottom of the viewfinder screen.

Setting the marker displays

The centre marker and safety zone marker displays are set on the VF MARKER screen.

- 1 Perform the menu operations (pages 86 to 88) to open the “VF MARKER” screen of FILM (CAM) MAIN MENU 2.

```
→< VF MARKER >
SAFETY ZONE   :3
CENTER MARK   :ON
FRAME SIG     :4:3
MARK          :OFF
LVL           :15
```

- 2 Perform the same operations as for the “VF DISPLAY” screen to set each item.

Viewfinder screen status displays

Setting the camera ID

The camera ID is set on the CAMERA ID screen. Up to ten alphanumeric, symbols and spaces can be used.

<Note>

The camera ID is not displayed while the setting menu is displayed even if colour bar signals are output.

- 1 Perform the menu operations (pages 86 to 88) to open the “CAMERA ID” screen of FILM (CAM) MAIN MENU 2.

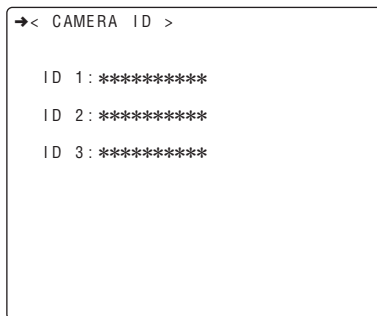

- 2 Turn the JOG dial button to move the arrow (cursor) to the “ID 1: to 3:” item.

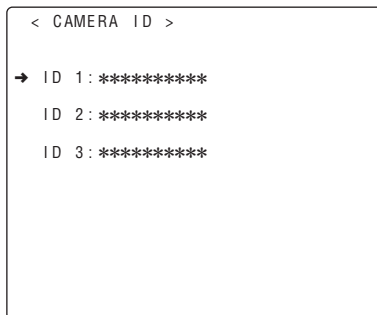

- 3 When the JOG dial button is pressed, the arrow (cursor) moves to the ID input area, and the input mode is established.

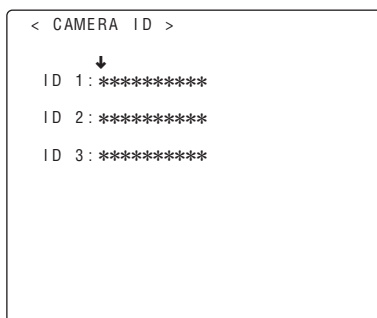

- 4 Press the JOG dial button again and turn it until the character to be set is displayed.

When the button is turned, the character displayed is switched in the following sequence:

Space: □



letters: A—Z



numbers: 0—9



symbols: ', >, <, /, -

- 5 Press the JOG dial button to enter the character.

- 6 Turn the JOG dial button to move the arrow (cursor) to the next position (right), and repeat steps 4 and 5 to set the characters.

- 7 When the characters have been input, turn the JOG dial button to move the arrow (cursor) to the “:” position.

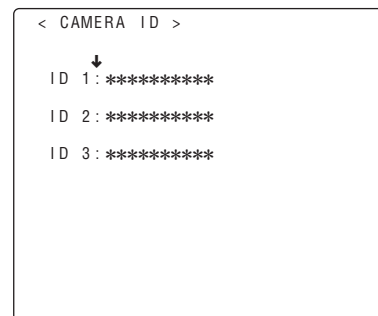

- 8 When the JOG dial button is pressed, the arrow (cursor) returns to the ID 1:, ID 2: or ID 3: item.

- 9 Press the MENU button to exit the menu operations.

The setting menu is cleared, and the displays showing the unit’s current statuses appear at the top and bottom of the viewfinder screen.

<Note>

The camera ID is recorded at the same time as the colour bar signals if “CAMERA ID” on the VF INDICATOR screen has been set to “ON.”

Screen displays

Remaining battery charge and audio channel level and remaining tape displays

Remaining tape display

The remaining tape time is displayed using 7 segments. The remaining tape time indicated by each segment is set to 3 minutes or 5 minutes using TAPE REMAIN/  on the VTR MENU "BATTERY/TAPE" screen. Each time the number of minutes set for the segments elapses, one segment is cleared. (See page 116)

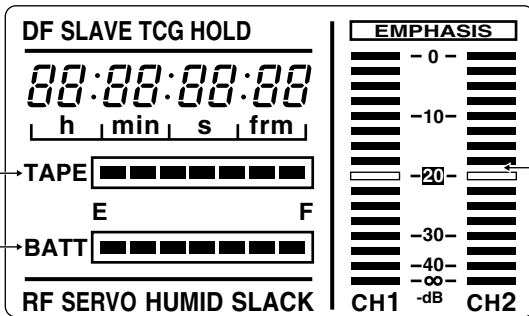

Remaining battery charge display

If a battery with a digital display (% display) is used, all 7 segments up to the "F" position light when the 70% or more of the battery charge remains. When there is less than 70% of the battery charge remaining, the segments go out one by one in sequence every time the remaining charge drops by 10%.

Audio channel level meter

Displays relating to errors and warnings

Error code display

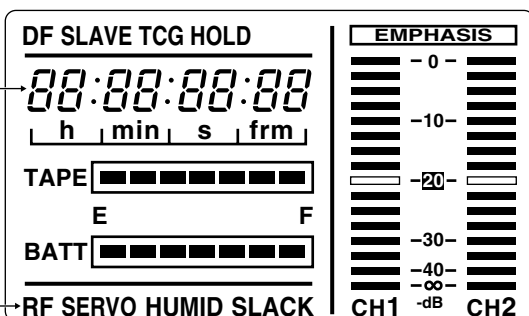

Warning displays

RF : Clogged video head
SERVO : Servo disturbance
HUMID : Formation of condensation on the head drum
SLACK : Problem in tape take-up

Displays relating to time codes

These displays light for the time code, CTL and actual time

DF : Drop frame mode
SLAVE : External locking of the time code
HOLD : Time code generator in the hold mode (when the HOLD button has been pressed)

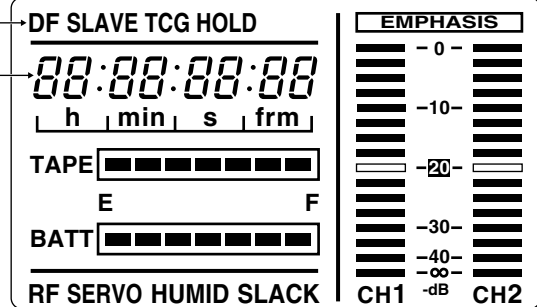

Time counter display

This displays the time code, CTL, user's bit and actual time. For the correlation between the items displayed and the switches, refer to the next section.

Time code-related switch settings and display items

TCG switch position	DISPLAY switch position	Display item
SET	TC or CTL	Time code
	UB	User's bit
F-RUN or R-RUN	CTL	CTL
	TC	Time code
	UB	User's bit

<Note>

If the HOLD button is pressed while the DISPLAY switch is set to UB, "HOLD" on the counter display will flash for as long as the switch is held down, and the VITC user's bit information recorded in the video AUX area will appear on the counter display.

For details, refer to "Warning system" (pages 124 and 125).

Adjusting the date and time

Adjustments and setup using the setting menus

1 Perform the menu operations (pages 86 to 88), and display the “TIME/DATE” screen of VTR MAIN MENU.

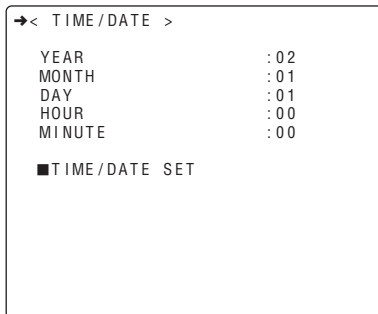

5 Press the MENU button to exit the menu operations.

The setting menu is cleared, and the displays showing the unit’s current statuses appear at the top and bottom of the viewfinder screen.

<Note>

The seconds cannot be set. The time always advances from 0 seconds.

2 Turn the JOG dial button to select the item to be changed, and press the JOG dial button.

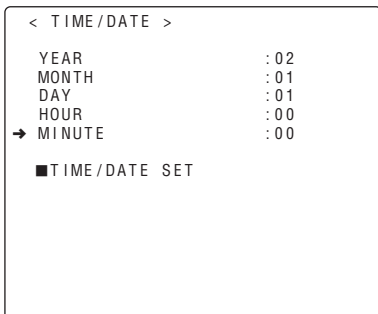

3 Turn the JOG dial button to change the setting, and press the JOG dial button to enter the setting.

4 When the settings are completed, turn the JOG dial button to select ■ TIME/DATE SET, and press the JOG dial button.

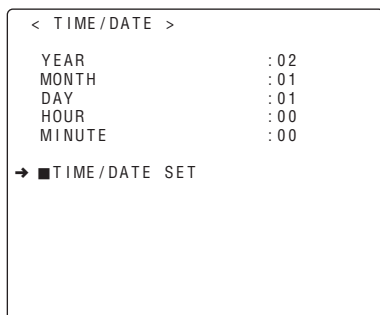

Adjusting the white balance and black balance

Adjusting the white balance

A better picture can be achieved by adjusting the white balance and black balance in the following sequence: AWB (white balance adjustment) → ABB (black balance adjustment) → AWB.

There is usually no need to re-adjust the black balance even when the power has been turned off and back on.

The white balance must always be re-adjusted when the lighting conditions have changed.

If the display mode is set to “2” or “3,” messages advising the user of what progress has been made in the adjustments and what the adjustment results are appear on the viewfinder screen when the black balance or white balance adjustment is commenced. Set the display mode to “1” if these messages are not to be displayed.

- For details on the display mode settings, refer to “Display modes and setting change messages” (page 48).

<Notes>

- ABB must be performed when the MASTER GAIN levels have been changed on the LOW SETTING, MID SETTING and HIGH SETTING screens of the FILM (CAM) MAIN MENU 1, when the super gain setting has been changed using the USER button, and when the GAMMA (ON/OFF) has been switched on the CAMERA SETTING screen.
- With artificial lighting—particularly fluorescent lights and mercury lamps—the luminance may appear to be constant but the intensity of the R, G and B colours will change in synchronization with the power line frequency. Especially in regions with a 50 Hz power line frequency, mutual interference arises between the vertical sync frequency (approx. 60 Hz) of this unit and lighting frequency (50 Hz). As a result, the hue tends to change with the passage of time or flickering occurs, making it impossible to achieve a proper white balance. It is recommended that the white balance be achieved using the settings shown in the table below.

Power line frequency	Shutter speed
50 Hz	1/100
60 Hz	OFF

- 1 Set the switches as shown in the figure.

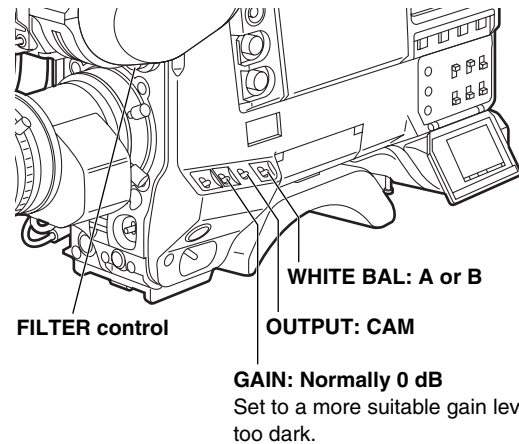

When the GAIN and WHITE BAL switch settings are changed, messages advising the user of the set positions appear on the setting change message display of the viewfinder screen. (However, this happens only when “3” has been set as the display mode.)

- 2 Select the FILTER control setting in accordance with the lighting conditions.
 - For examples of the FILTER control settings, refer to the description of the FILTER control (page 15) in the “Shooting (recording)/playback function section.”When the FILTER control setting is changed, a message advising the user of the set positions appears on the setting change message display of the viewfinder screen. (However, this happens only when “3” has been set as the display mode.)

Adjusting the white balance and black balance

Adjusting the white balance

3 Erect a white pattern at a place with the same conditions as the source of light illuminating the subject, zoom in, and shoot the white of the pattern on the screen.

A white object (such as a white cloth or white wall) near the subject may be used as a substitute for the white pattern.

The size of the white object required is shown in the figure below.

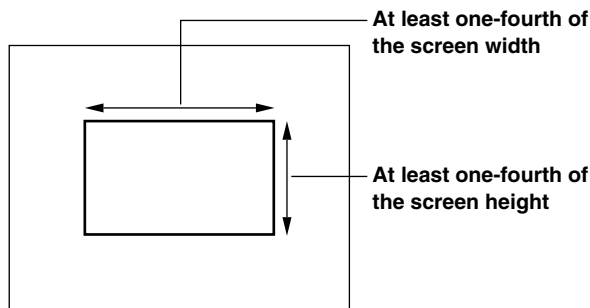

<Notes>

- Take care to keep high-brightness spots off the screen.
- Shoot white objects in the centre of the screen.

4 Adjust the lens aperture.

5 Set the AUTO W/B BAL switch to AWB, and then release it.

The switch returns to the centre, and the white balance is automatically adjusted.

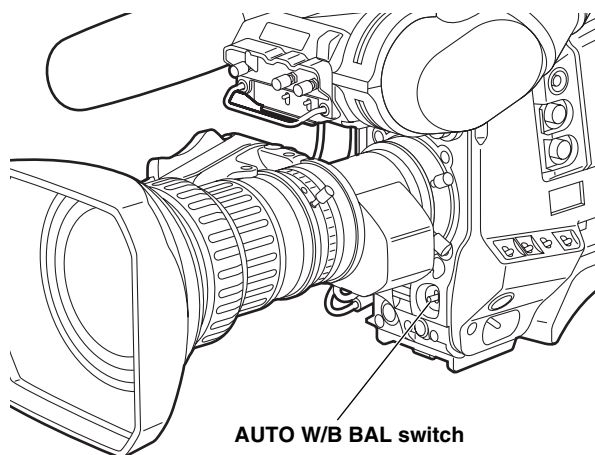

<Note>

When the AUTO W/B BAL switch is pressed again to the AWB side when the white balance is being adjusted automatically (AWB ACTIVE), the adjustment operation will stop.

The adjusted value in this case is the value before automatic adjustment was performed.

6 While the adjustment is in progress, the following message appears on the viewfinder screen (but only when “2” or “3” has been set as the display mode).

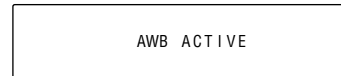

Message appearing while the adjustment is in progress

7 Adjustment is completed in several seconds. (A message similar to the one shown in the figure now appears.)

The adjustment value is automatically saved in the memory (A or B) which was set in step **1**.

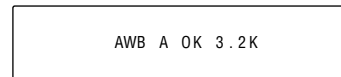

Message appearing upon completion of the adjustment

8 A message such as the following appears if the colour temperature of the subject is lower than 2300 K or higher than 5600 K.

The downward pointing arrow indicates that the colour temperature is lower than the display temperature; conversely, the upward pointing arrow indicates that the it is higher than the display temperature.

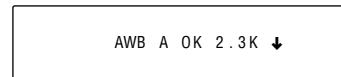

When the colour temperature is lower than 2300 K

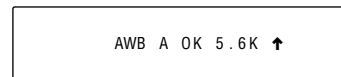

When the colour temperature is higher than 5600 K

<Note>

When a zoom lens with an automatic aperture function is used, aperture hunting may occur. Adjust the aperture's gain control (marked as IG, IS, S, etc.) provided with the lens.

For details, refer to the operating instructions which accompany the lens.

Hunting:

The auto iris response is repeated, causing the brightness levels of the image to become inconsistent.

Adjusting the white balance and black balance

Adjusting the white balance

When the white balance cannot automatically be adjusted

An error message appears on the viewfinder screen (when “2” or “3” has been set as the display mode).

Messages relating to white balance adjustment

Error message	Meaning	Recommended action
COLOR TEMP. HIGH	Colour temperature is too high.	Select a suitable filter.
COLOR TEMP. LOW	Colour temperature is too low.	Select a suitable filter.
LOW LIGHT	There is not enough light.	Increase the amount of light or increase the gain.
LEVEL OVER	There is too much light.	Reduce the amount of light or reduce the gain.
UNSTABLE CONDITION	The shooting conditions are unstable (shooting under fluorescent light, unstable camera posture, etc.).	If flickering is to blame, install the shutter, and stabilize the shooting conditions.
CHECK FILTER	The setting position of the filter selector control is not correct.	Check the filter selector control.

When any of the error messages listed above is displayed, take the recommended action, and try adjusting the white balance again.

If the error message persists even after repeated attempts, consult your dealer.

<Notes>

On rare occasions, AWB cannot be adjusted and a NG display appears. In a case like this, adjust AWB again.

When there is no time to adjust the white balance

Set the WHITE BAL switch to PRST. The white balance for the filter is achieved in accordance with the setting position of the FILTER control (outer).

White balance memories

There are two sets of white balance memories, A and B.

When the FILTER INH setting on the CAMERA SW MODE screen of FILM (CAM) MAIN MENU 4 is ON (default setting), the number of memories for set A and set B is limited to one each. In this case, the memory contents are not coupled with the filter.

When FILTER INH is set to OFF, the adjustment values for each filter can be automatically saved in the memories corresponding to the WHITE BAL switch settings (A or B). This unit contains four filters so that a total of 8 (4×2) adjustment values are saved.

White balance search area

It is possible to set the white balance search area to either 90%, 50% or 25% by changing the AWB AREA setting on the OPTION screen of the FILM (CAM) MAIN MENU 4.

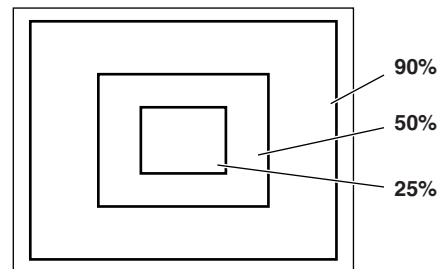

When using the unit in film mode

When there is a large difference between the CC filter setting and the colour temperature of the subject, the dynamic range of the video signals may not be utilized to full potential.

We recommend that the CC filter setting selected is one that is close to the colour temperature of the subject.

Adjusting the white balance and black balance

Adjusting the white balance

When FILTER INH is set to ON

When AWB is adjusted, the colour temperature and filter number applying at the time are displayed.

If the filter is then turned, the colour temperature and filter number are displayed.

The white balance is almost fully adjusted if the subject is illuminated at a colour temperature approaching the one displayed.

(Example of display)

AWB A OK 3.2K

AWB is adjusted using subject filter (B) with a lighting colour temperature of 3200 K.



The filter is changed to filter (C)



CC : C
4.3K

“4.3 K” is displayed.

(1): This indicates that AWB was adjusted using the filter.



If the colour temperature of the subject in this state is near 4.3 K, the white balance is right and so the camera can be used.



The filter (B) is restored.



3.2K

“3.2 K” is displayed, and the status when AWB was first adjusted is indicated.

Adjusting the white balance and black balance

Adjusting the black balance

The black balance needs to be adjusted in the following cases:

- When the unit is used for the first time
- When the unit is used after it has not been used for a prolonged period of time
- When the unit is used in an ambient temperature which has fluctuated significantly
- When the value selected for the gain switch has been changed
- When the super gain setting has been performed using the USER button
- When the gamma ON/OFF setting has been changed
- When the frame rate setting has been changed

1 Set the switches as shown in the figure.

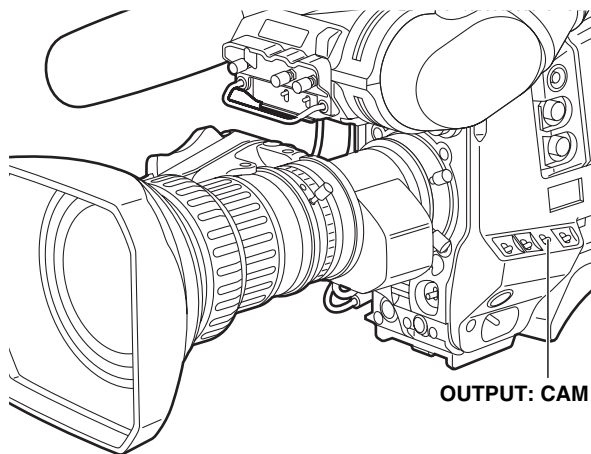

2 Set the AUTO W/B BAL switch to the ABB position, and then release it. The switch returns to the centre, and the adjustment is performed.

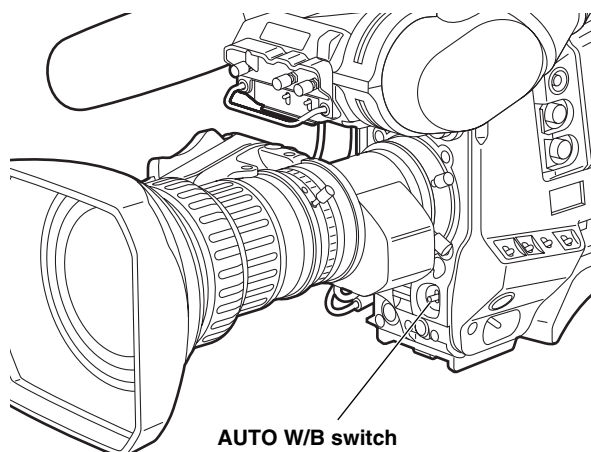

3 While the adjustment is in progress, the following message appears on the viewfinder screen (but only when "2" or "3" has been set as the display mode).

<Note>

While the adjustment is in progress, the lens aperture is automatically set to CLOSE.

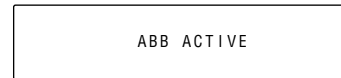

Message appearing while the adjustment is in progress

4 Adjustment is completed in several seconds. (A message similar to the one shown in the figure now appears.)

The adjustment value is automatically saved in the memory.

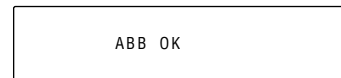

Message appearing upon completion of the adjustment

<Notes>

- Check that the lens connector has been connected and that the lens aperture is set to CLOSE.
- While the black balance is being adjusted, the aperture is automatically set to the light-shielding status.
- While the black balance is being adjusted, the gain selector circuit is switched automatically. Flicker or noise may appear on the viewfinder screen, but this is not indicative of malfunctioning.
- If black shading is not satisfactory even with ABB OK, open the BLACK SHADING screen of FILM (CAM) MAIN MENU 4, and adjust the black shading. (Refer to page 110.)
- When the super gain has been set to ON, the black balance is executed at the preset position in the white balance memory.
- When the AUTO W/B BAL switch is pressed again to the ABB side when the black balance is being adjusted automatically (ABB ACTIVE), the adjustment operation will stop. The adjusted value in this case is the value before automatic adjustment was performed.

Setting the electronic shutter

Shutter modes

Available shutter modes and shutter speeds

Mode	Shutter speed	Application
Fixed	POSITION 1 to 6	For shooting fast-moving subjects clearly
SYNCHRO SCAN	Aperture angle: 3 to 350 degrees (0.8% to 97.2% of the frame rate)	For shooting in such a way that the horizontal striping is minimized on the monitor screen

<Notes>

- No matter in which mode the electronic shutter is used, the higher the shutter speed, the lower the camera's sensitivity.
- When the aperture is in the automatic mode, it will increasingly open and the depth of focus will become shallower as the shutter speed is increased.

Registering the shutter speed

The shutter speed is registered in the "SHUTTER SELECT" screen of FILM (CAM) MAIN MENU 2.

- 1 Perform the menu operations (pages 86 to 88), and display the "SHUTTER SELECT" screen.

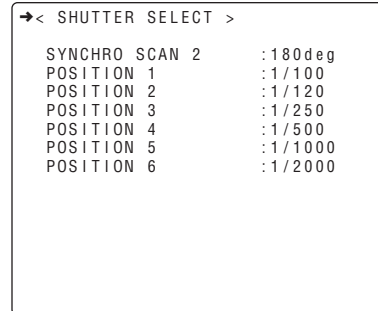

- 2 Turn the JOG dial button to move the arrow (cursor) to the desired item.
- 3 Press the JOG dial button to set the shutter speed to be changed. Turn the JOG dial button to select ON or OFF, and press the button to enter the setting.

It is possible to set a fixed speed within the range of 90.0 to 225.0 degrees (in units of 0.5 deg.) in SYNCHRO SCAN 2.

It is also possible to set 6 different shutter speeds in POSITION 1 to 6, respectively.

1/100 , 1/120, 1/250, 1/500, 1/1000 and 1/2000 sec.
(or 180.0, 172.8, 144.0, 120.0, 90.0 and 45.0 deg)

- 4 Press the MENU button to exit the menu operations. The setting menu is cleared, and the displays showing the unit's current statuses appear at the top and bottom of the viewfinder screen.

Setting the electronic shutter

Setting the shutter mode and speed

- The SHUTTER switch is used to set the shutter speed and the shutter speed in the fixed mode.
- The shutter speed in the SYNCHRO SCAN mode can easily be changed using the SYNCHRO (“+” and “-”) buttons.
- On the SHUTTER SPEED screen of FILM (CAM) MAIN MENU 2, the setting range of the shutter speed can be restricted to the required range and whether or not to use the special operation mode (SYNCHRO SCAN) can be selected.

1 Following the steps for “Switching the display mode” (page 49), set DISP MODE to “2” or “3” on the VF DISPLAY screen of FILM (CAM) MAIN MENU 2.

2 Press the SHUTTER switch from ON to SEL. The current shutter setting appears on the setting change message display area of the viewfinder screen.

Example: “1/120,” “50.0%,” etc.

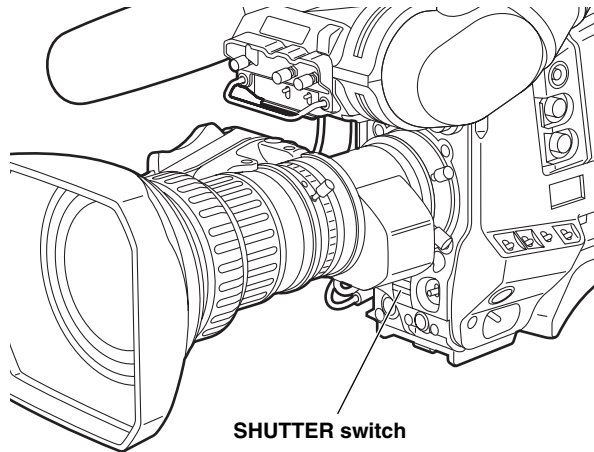

3 Press the SHUTTER switch to the SEL position again, and repeat this until the desired mode or speed is displayed. When all the modes and speeds are displayed, the display will change in the sequence shown below. When the required shutter speed and mode have been assigned beforehand, only the assigned speed or mode will be displayed.

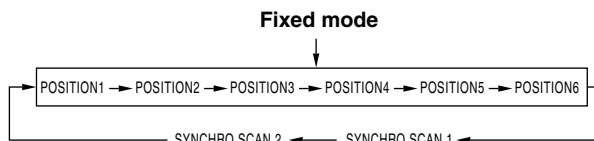

Changing the shutter speed and mode selection range

On the SHUTTER SPEED screen of FILM (CAM) MAIN MENU 2, the setting range of the shutter speed can be restricted to the required range and whether or not to use the special operation mode (SYNCHRO SCAN) can be selected.

1 Perform the menu operations (pages 86 to 88), and display the “SHUTTER SPEED” screen.

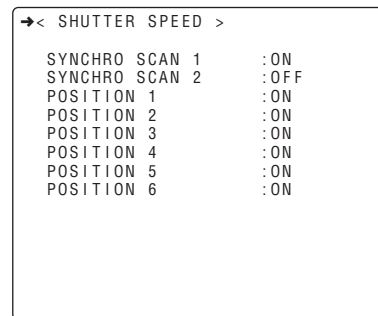

2 Turn the JOG dial button to move the arrow (cursor) to the desired item.

3 Press the JOG dial button to set the item to be changed. Turn the JOG dial button to select ON or OFF, and press the button to enter the setting.

4 Press the MENU button to exit the menu operations. The setting menu is cleared, and the displays showing the unit’s current statuses appear at the top and bottom of the viewfinder screen.

<Notes>

- When operating the unit from the AJ-EC3 extension control unit (optional accessory), the shutter speed selected by the AJ-EC3 switch will take precedence in determining the actual shutter speed even when operations have been performed on the unit’s SHUTTER SPEED screen.
- For details on selecting the engineer mode and display screens, refer to “Menu operations” (pages 86 to 88).

Setting the electronic shutter

Setting the synchro scan mode

- 1 Press the SHUTTER switch from ON to SEL and set to SYNCHRO SCAN.

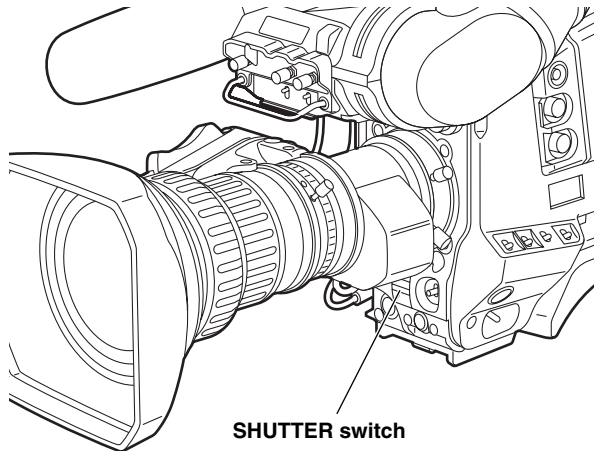

- 2 In the SYNCHRO SCAN mode, continuous switching inside the 3.0 deg to 350.0 deg (0.8% to 97.2%) range can be achieved by pressing the SYNCHRO (“+” and “-”) buttons.

Switching the shutter speed display

The unit enables the SYNCHRO SCAN mode to be displayed on the viewfinder screen to be switched to “1/*** (sec.),” “***%” or “***d (angle)” on the VF DISPLAY screen of FILM (CAM) MAIN MENU 2.

- 1 Perform the menu operations (pages 86 to 88), and open the VF DISPLAY screen.

```
→< VF DISPLAY >
DISP CONDITION :NORMAL
DISP MODE      :3
VF OUT         :Y
VF DTL         :4
ZEBRA1 DETECT  :070%
ZEBRA2 DETECT  :085%
ZEBRA2         :SPOT
LOW LIGHT LVL  :45%
SYNCHRO SCAN DISP.:deg
ECU MENU DISP. :ON
```

- 2 Turn the JOG dial button to move the arrow (cursor) to the SYNCHRO SCAN DISP. item.

```
< VF DISPLAY >
DISP CONDITION :NORMAL
DISP MODE      :3
VF OUT         :Y
VF DTL         :4
ZEBRA1 DETECT  :070%
ZEBRA2 DETECT  :085%
ZEBRA2         :SPOT
LOW LIGHT LVL  :45%
→ SYNCHRO SCAN DISP.:deg
ECU MENU DISP. :ON
```

- 3 Press the JOG dial button to set the SYNCHRO SCAN display mode.

Turn the JOG dial button, select the display, and then press the JOG dial button to enter the selection.

sec (seconds): 1/***

% :***%

deg (angle) :***d

e.g.

When the frame rate is set to 24 fps and exposure time is set to half:

1/48 sec = 50% = 180 deg.

- 4 Press the MENU button to exit the menu operations.

The setting menu is cleared, and the displays showing the unit's current statuses appear at the top and bottom of the viewfinder screen.

Film tone gamma function

The unit incorporates a total of three gamma curves—two cine curves (for films/for videos) and the conventional video gamma curve—and it enables the curve that best suits the application at hand to be selected.

Switching from the film mode to video mode or vice versa can be accomplished using the CAM MENU SEL item on the OPTION screen of FILM (CAM) MAIN MENU 4.

Two gamma curves (for films/for videos) are available in the film mode. They can be set by selecting the CINE GAMMA SEL item on the GAMMA screen of FILM MAIN MENU 1.

Video mode (VIDEO MENU)

This is the optimum mode for playing back the images recorded on tape using a video component. The images are processed using the conventional video gamma characteristics.

Film mode (FILM MENU)

Two types of film-like images can be achieved in this mode.

FILM REC (for films: film gamma)

This is the optimum mode for printing the images recorded on tape onto film and presenting them. The images are processed using the film-use cine gamma characteristics developed by Panasonic.

VIDEO REC (for videos: film tone gamma)

Even when playing back images recorded on tape using a video component, this mode provides a wide dynamic range, enabling images to be played back in a mode where the images are more like film images than the conventional video images.

The images are processed using the video-use cine gamma characteristics developed by Panasonic.

The menu settings performed in the film mode and video mode are saved separately.

Switching the frame frequency

This unit allows the frame frequency to be switched to 60.00 Hz or 59.94 Hz to provide support in areas with different video systems. The frame frequency can be switched on the OPTION screen of FILM (CAM) MAIN MENU 4.

1 Perform the menu operations (pages 86 to 88), and open the OPTION screen.

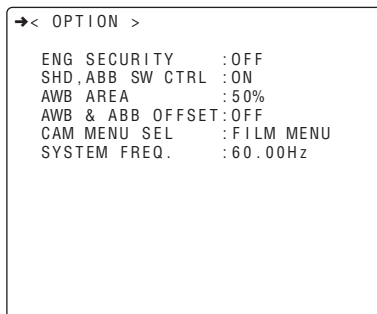

2 Turn the JOG dial button to move the arrow (cursor) to the SYSTEM FREQ item.

3 Press the JOG dial button to set the item to be used.

Turn it to select the frequency, and then press it to enter the selection.

At this time, the **TURN OFF POWER** message flashes on the display.

4 Press the MENU button to exit the menu operations.

The setting menu is cleared, and the displays showing the unit's current statuses appear at the top and bottom of the viewfinder screen.

5 Set the POWER switch to OFF to turn off the power.

The frame frequency will be switched when it is turned back on.

Press the MODE CHECK button to check that the frame frequency has been switched.

Variable frame rate

This camera/VTR enables the frame rate (shooting speed) to be set from 4 fps to 60 fps. Since the 720P/59.94 Hz or 720P/60.00 Hz format is used for recording onto the tape or outputting to the HD SDI OUT connector, users now have the exciting opportunity to create a whole new dimension of moving images with clearer slow-motion images and blur effects—a world which was hitherto confined to the field of film production—in their own video productions.

This unit automatically stores as the tape management information both the frame rate information which indicates the shooting speed and the active frame information which indicates the first frame where the frame image was switched in the user's bit of the sub-code track area (this used to be the LTC area). This information is output from the TC OUT connector and HD SDI OUT connector. Further, the active frame information is stored in the least significant digit of the user's bit while the frame rate information is stored in its lower third and fourth digits.

Setting the frame rate

There are two ways in which the frame rate can be set.

Using menu operations

- 1 Perform the menu operations (pages 86 to 88), and display the "FRAME MODE" screen of FILM (CAM) MAIN MENU 2.

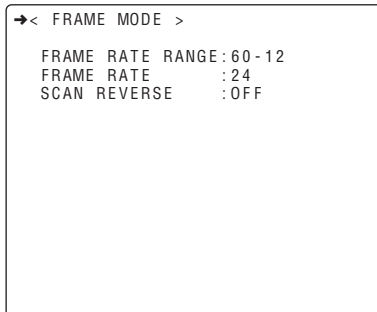

- 2 Turn the JOG dial button to move the arrow (cursor) to the "FRAME RATE" item.
- 3 Press the JOG dial button, and set the desired frame rate. Turn the JOG dial button to select the frame rate, and press the JOG dial button to enter the selection.

- 4 Press the MENU button to exit the menu operations.

The setting menu is cleared, and the displays showing the unit's current statuses appear at the top and bottom of the viewfinder screen.

Using the synchro scan adjustment switches ("+" and "-")

- 1 Set the unit to a status other than the menu operation status.
- 2 When the JOG dial button is pressed, the frame rate information display at the top left of the viewfinder screen starts flashing.

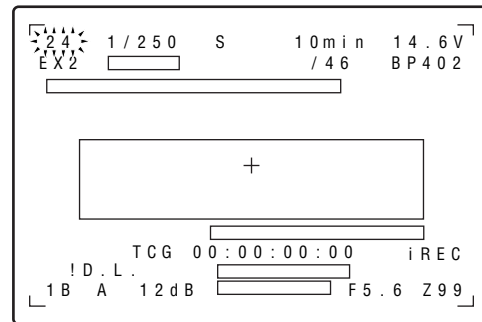

- 3 Press the synchro scan adjustment switches ("+" and "-") to set the desired frame rate.

<Note>

After about 5 seconds, the frame rate information display stops flashing and lights. Press the synchro scan adjustment switches ("+" and "-") while this display is flashing.

- 4 Press the JOG dial button to enter the frame rate. Refrain from further operation, and in about 5 seconds the frame rate information display on the viewfinder screen will stop flashing, and the frame rate will be set.

<Note>

When the frame rate has been changed, adjust the black balance once again.

Variable frame rate

<Notes>

In this unit, the frame rate is set by changing the storage time of the optical signals sensed by the CCD. Depending on the frame rate setting, the following problems may arise.

① White streaks

The dark current of the photodiode that configures the CCD's pixels causes defective pixels to arise, and this results in the appearance of white streaks on the screen. This current increases in direct proportion to the rise in the CCD's temperature and storage time in the photodiode.

In short, the white streaks increase in inverse proportion to the frame rate setting.

When a lower frame rate setting is desired, reduce the master gain setting and, where possible, avoid direct sunlight and use the unit in a cool environment.

② Delayed response time in automatic processing

When the frame rate setting has been lowered, it takes longer for the unit to perform the automatic processing (such as auto white balance, flare compensation, auto knee and auto iris), possibly giving the user the impression that something is odd or wrong.

The response time for automatic processes is particularly slow at a frame rate of 20 fps and below.

When the frame rate has been set to 20 fps or below, it is recommended that the unit be operated with the automatic processing released.

③ Disturbed images

The images may be disturbed for a moment if scene-to-scene continuity is performed while the time code is allowed to advance in the rec run mode when the frame rate is set to 24 fps or 30 fps. This occurs in order to reset the video signals from the camera so as to maintain the continuity of the time code recorded on the tape.

The disturbed images are not recorded on the tape but they will affect the signals which are output from the HD SDI OUT connector.

Furthermore, if the time code is allowed to advance in the free run mode when the frame rate is set to 24 fps or 30 fps, at that instant when the time code is preset or the time code is locked to the external signal, the images may be disturbed for a moment.

Scan reverse

Using an HD lens adapter made by Angenieux, this unit supports the ultra-prime lenses used for film cameras as a standard feature. Furthermore, it can also select the setting of the scan reverse function for canceling the image correction (reversal of the top/bottom and left/right of the images) that is performed when this adapter is used.

Setting the scan reverse

- 1 Perform the menu operations (pages 86 to 88), and display the “FRAME MODE” screen of FILM (CAM) MAIN MENU 2.

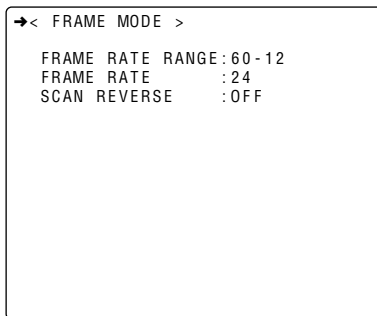

- 2 Turn the JOG dial button to move the arrow (cursor) to the “SCAN REVERSE” item.
- 3 Press the JOG dial button, and set the desired scan reverse.
Turn the JOG dial button, ON or OFF and press the JOG dial button to enter the selection.
- 4 Press the MENU button to exit the menu operations.
The setting menu is cleared, and the displays showing the unit’s current statuses appear at the top and bottom of the viewfinder screen.

Adjusting the audio level

When the AUTO SELECT CH1 and CH2 selector switches are set to AUTO, the audio CH1 and CH2 input levels are adjusted automatically.

Proceed as follows to adjust the audio channel 1 and 2 levels manually.

Manual audio level adjustments

- 1 Set the AUTO SELECT CH1 and CH2 selector switches to MAN.
- 2 Adjust the AUDIO LEVEL CH1 and CH2 controls in such a way that, when audio signals are input, the level meter reading will not exceed 0 dBu even under maximum signal input level conditions.

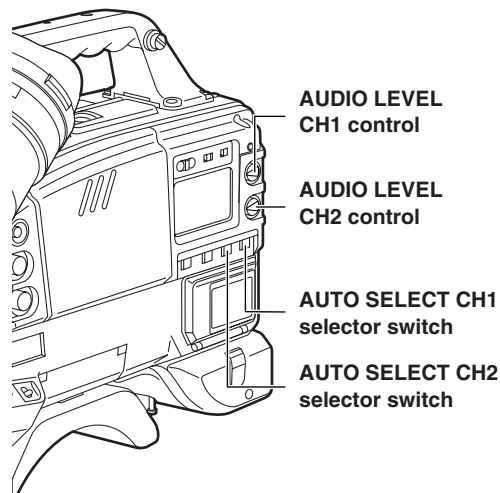

Limiter

When the audio levels have been adjusted manually, the limiter circuit is tripped by an excessively high input level. This circuit can be turned ON or OFF on the MIC/AUDIO screen of the VTR menu.

(The factory setting is OFF.)

Setting the time data

When the user's bit and time code are both to be used, the user's bit is set first.

If the time code is set first, the time code generator will stop while the user's bit is being set so that the time code setting will be off.

The time code setting range extends from 00:00:00:00 to 23:59:59:29.

Setting the user's bit

In the internal colour bar signal recording mode, memos (dates and times) of up to eight hexadecimal digits can be recorded on the sub-code track by setting the user's bit.

1 Set the OUTPUT (output signal selector)/AUTO KNEE switch to BARS.

2 Set the DISPLAY switch to UB.

3 Set the TCG switch to SET.

4 Set the user's bit using the SHIFT button, "+" button and "-" button.

SHIFT button:

This is used to start the digit to be set flashing. Each time it is pressed, the flashing moves by one digit to the right.

"+" button:

This increments by 1 the numerical value of the flashing digit.

"-" button:

This decrements by 1 the numerical value of the flashing digit.

A to F in hexadecimal notation are displayed as follows:

Hexadecimal notation	A	B	C	D	E	F
Display	A	b	c	d	E	F

5 Set the TCG switch to F-RUN or R-RUN.

6 Select UB MODE item on the TC/UB screen of VTR MENU.

User's bit memory function

The user's bit settings (except for the actual time) are automatically saved in the memory and retained even after the power is turned off.

<Notes>

- In the camera image recording mode, the tape management information shown on page 68 is output.
- When DATE is selected from the UB MODE items, the real time operations for year/month/day of the TIME/DATE screen are adhered to.
- When TIME is selected from the UB MODE items, the real time operations for hours/minutes/seconds of the TIME/DATE screen are adhered to.
- The user's bit setting contents are output to the six higher digits of the user's bit in the VIDEO AUX area (which used to be the VITC area). In the internal colour bar signal recording mode, they are also output to the six higher digits of the LTC user's bit.
- The user's bit cannot be set since the active frame information and other tape management information is always output to the two lower digits of the user's bit.

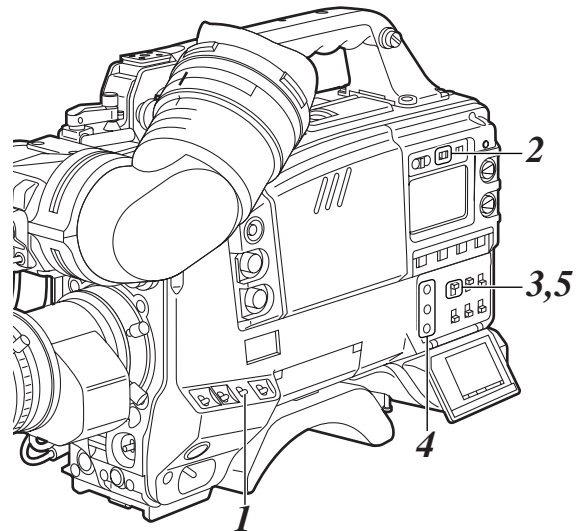

Setting the time data

Setting the time code

- 1** Set the DISPLAY switch to TC.
- 2** Set the TCG switch to SET.
- 3** Switch the TC MODE to DF or NDF on the TC/UB screen of VTR MENU.
Select DF to run the time code in the drop frame mode or select NDF to run the time code in the non-drop frame mode.
- 4** Set the time code using the SHIFT button, “+” button and “-” button.
SHIFT button:
This is used to start the digit to be set flashing. Each time it is pressed, the flashing moves by one digit to the right.
“+” button:
This increments by 1 the numerical value of the flashing digit.
“-” button:
This decrements by 1 the numerical value of the flashing digit.
- 5** Select the TCG switch position.
Select F-RUN for running the time code in the free-run mode or select R-RUN for running it in the rec-run mode.
- 6** Set the number of frames per seconds (24, 25 or 30) displayed in the frame digits of the time code using the TC DISP SEL item on the TC/UB screen of VTR MENU.
The time code is converted to the number of frames which has been set here, and displayed.

<Notes>

- When the frame rate is set to 24 fps, this unit will perform the processing in the non-drop frame mode in order to maintain the continuity of the frames even when the time code has been set to the drop frame mode.
Furthermore, when the frame rate has been set to 24 fps, it will not be possible to set the time code while recording is in progress since the images will be disturbed if the advancing of the time code is discontinuous.
- When the frame frequency has been set to 60.00 Hz, the unit always performs the processing in the non-drop frame mode.

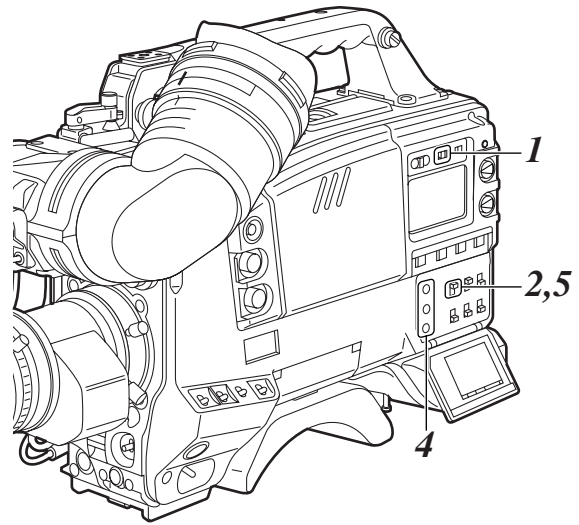

Time code when the battery is replaced

The backup function works even when the battery is replaced, and the time code generator continues to operate for a prolonged duration (approx. 1 year).

<Note>

When the POWER switch is set to ON → OFF → ON, the backup accuracy of the time code is approximately ± 2 frames.

Setting the time data

Externally locking the time code

- 1 Set the POWER switch to ON.
- 2 Set the TCG switch to F-RUN.
- 3 Set the DISPLAY switch to TC.
- 4 Supply the reference time code and reference video signal which are in a phase relationship that satisfies the time code standard to the TC IN connector and GENLOCK IN connector respectively.

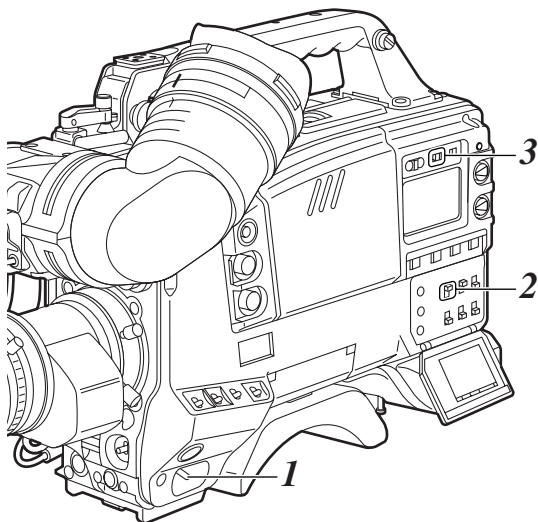

Example of connections for external lock

The time code generator of the VTR unit can be locked to an external generator.

When locking to an external signal

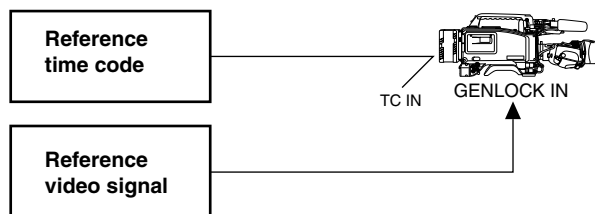

The built-in time code generator is now locked to the reference time code.

About 10 seconds after locking, the external lock status will be retained even if the connection of the externally supplied reference time code is disconnected. However, the servo lock will be subject to disturbances if it is connected or disconnected during recording (REC).

<Note>

When the external lock operation is performed, the time code is instantly locked to the external time code, and the same value as the external code value appears on the counter display.

Do not set the unit to the recording mode during the few seconds it takes for the sync generator to stabilize.

User's bit setting when the time code is externally locked

When the time code is externally locked, only the time data is locked to the time data of the external time code.

This means that the user's bit can be set separately for each unit.

The user's bit can also be locked to the user's bit of the external time code. For details, consult your dealer.

To release the external lock

First stop supplying the external time code, and set the TCG switch to R-RUN.

When switching the power from the battery to an external power supply while the time code is externally locked

In order to ensure the continuity of the time code generator's power, connect the external power supply to the DC IN connector, and then remove the battery pack. If the battery pack is removed first, no guarantees can be made for the continuity of the external locking of the time code.

Gen-locking of the camera unit while the time code is externally locked

While the time code is externally locked, the camera unit is gen-locked by the reference video signal which is supplied to the GEN LOCK IN connector.

<Notes>

- When the frame rate is set to 24 fps, this unit will perform the processing in the non-drop frame mode in order to maintain the continuity of the frames even when the time code has been set to the drop frame mode.

Furthermore, when the frame frequency has been set to 60.00 Hz as well, the unit performs the processing in the non-drop frame mode.

If an external time code generator is used, set it to the non-drop frame mode.

- Use the same frame frequency setting for the reference time code and reference video signal as the unit's setting.

When the frame rate is used at 24 fps, the image may be disturbed if the frame frequencies differ.

Tape management information

This unit automatically stores as the tape management information both the frame rate information which indicates the shooting speed and the active frame information which indicates the first frame where the frame image was switched in the user's bit of the sub-code track area (this used to be the LTC area). This information is output from the TC OUT connector and HD SDI OUT connector. Further, the active frame information is stored in the least significant digit of the user's bit while the frame rate information is stored in its lower third and fourth digits.

Example of display

LTC user's bit

- When the internal colour bar signals are being recorded

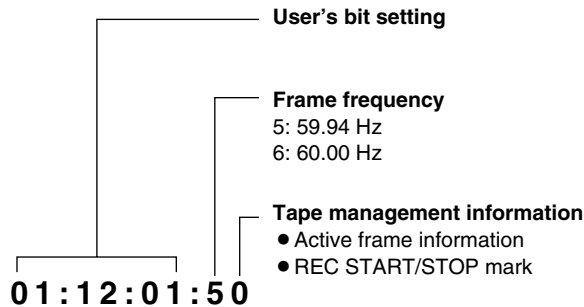

VITC user's bit

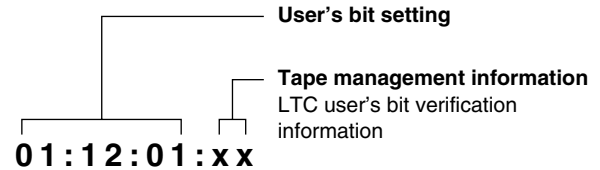

To verify the VITC user's bit, set the DISPLAY switch to UB, and hold down the HOLD button. While the HOLD button is held down, the VITC user's bit information appears on the counter display.

- When the camera's video signals are being recorded

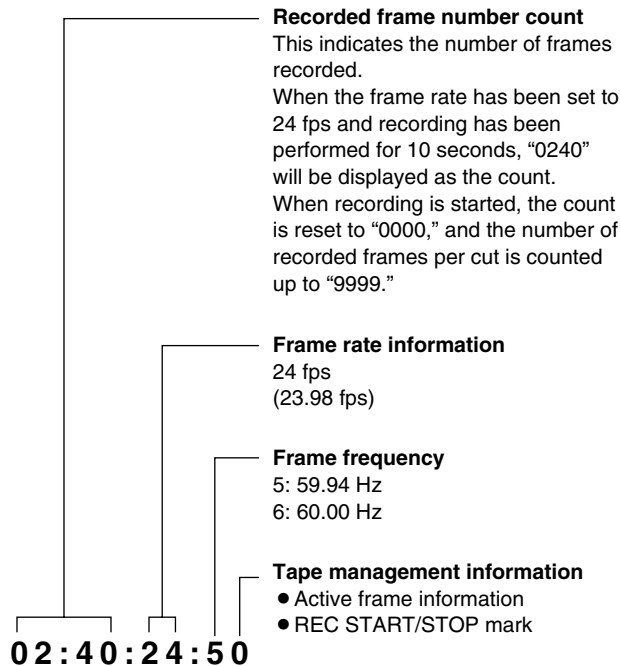

How to use the user data

The contents of the setting menus can be saved in the user area of the camera's memory, and they can be loaded from this area. Use of this data speeds up the process of reproducing suitable setup statuses.

User data operation

Menus are used to save the setting menu contents in the user area of the camera's memory and load them from this area.

Saving the user data

- 1 Perform the menu operations (pages 86 to 88), and display the "INITIALIZE" screen of FILM (CAM) MAIN MENU 4.

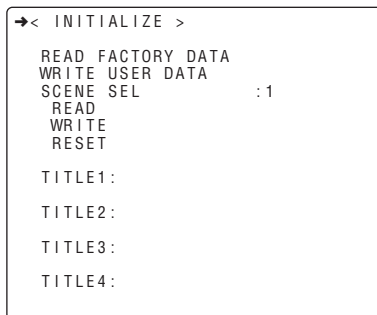

- 2 Turn the JOG dial button to move the arrow (cursor) to the WRITE USER DATA item.

- 3 When the JOG dial button is pressed, the following message appears.



- 4 Turn the JOG dial button to move the arrow (cursor) to YES, and press the JOG dial button. The data settings are saved in the user area of the camera's memory.

- 5 After the data has been saved, press the MENU button twice. The setting menu is cleared, and the displays showing the unit's current statuses appear at the top and bottom of the viewfinder screen.

Loading the user data

- 1 Perform the menu operations (pages 86 to 88), and display the "CAM CARD READ/WRITE" screen of FILM (CAM) MAIN MENU 3.

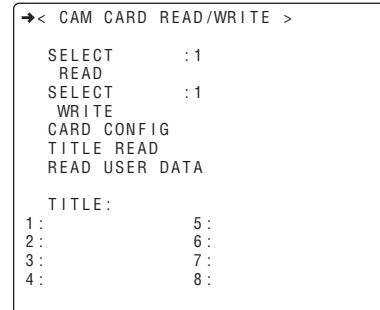

- 2 Turn the JOG dial button to move the arrow (cursor) to the READ USER DATA item.

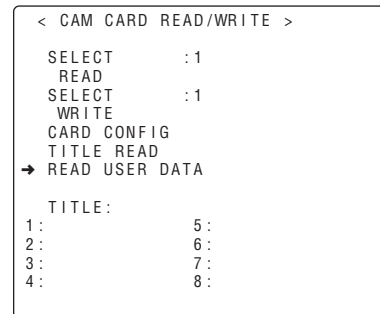

- 3 When the JOG dial button is pressed, the following message appears.



- 4 Turn the JOG dial button to move the arrow (cursor) to YES, and press the JOG dial button. The data settings saved in the user area of the camera's memory are loaded, and the settings are completed.

- 5 Press the MENU button twice. The setting menu is cleared, and the displays showing the unit's current statuses appear at the top and bottom of the viewfinder screen.

- 6 When the frame frequency setting has been changed, it is necessary to restart the unit by turning the POWER switch to OFF and then to ON again for the setting to be switched.

How to use the scene file

The contents of the setting menus can be saved in the scene file area of the camera's memory, and they can be loaded from this area. Four scene files are provided in the unit. Use of this data speeds up the process of reproducing suitable setup statuses.

Scene file operation

Menus are used to save the setting menu contents in the scene file area of the camera's memory and load them from this area.

Saving the scene file

- 1 Perform the menu operations (pages 86 to 88), and display the "INITIALIZE" screen of FILM (CAM) MAIN MENU 4.

```
→< INITIALIZE >
READ FACTORY DATA
WRITE USER DATA
SCENE SEL      :1
READ
WRITE
RESET
TITLE1:
TITLE2:
TITLE3:
TITLE4:
```

- 2 Turn the JOG dial button to move the arrow (cursor) to the SCENE SEL item.

- 3 When the JOG dial button is pressed, the scene file number starts flashing. Turn the JOG dial button to select the scene file in which data is to be saved.

```
< INITIALIZE >
READ FACTORY DATA
WRITE USER DATA
→ SCENE SEL      1
READ
WRITE
RESET
TITLE1:
TITLE2:
TITLE3:
TITLE4:
```

- 4 Press the JOG dial button to enter the scene file.

- 5 Turn the JOG dial button to move the arrow (cursor) to the TITLE1, TITLE2, TITLE3 or TITLE4 item that corresponds to the scene file whose title is to be provided.

```
< INITIALIZE >
READ FACTORY DATA
WRITE USER DATA
SCENE SEL      :1
READ
WRITE
RESET
→ TITLE1:
TITLE2:
TITLE3:
TITLE4:
```

- 6 When the JOG dial button is pressed, the arrow (cursor) moves to the title input area, and the input mode is established.

```
< INITIALIZE >
READ FACTORY DATA
WRITE USER DATA
SCENE SEL      :1
READ
WRITE
RESET
TITLE1: ↓
TITLE2:
TITLE3:
TITLE4:
```

- 7 Press the JOG dial button again and turn it until the character to be set is displayed. When the button is turned, the character displayed is switched in the following sequence:

Space:
↓
letters: A—Z
↓
numbers: 0—9
↓
symbols: ', >, <, /, -

- 8 Press the JOG dial button to enter the character.

- 9 Turn the JOG dial button to move the arrow (cursor) to the next position (right), and repeat steps 7 and 8 to set the characters (maximum of 8).

How to use the scene file

10 When the title has been input, turn the JOG dial button to move the arrow (cursor) to the “:” position.

```
< INITIALIZE >
READ FACTORY DATA
WRITE USER DATA
SCENE SEL      :1
READ
WRITE
RESET
↓
TITLE1:*****
TITLE2:
TITLE3:
TITLE4:
```

13 When the JOG dial button is pressed, the following message appears.

```
WRITE ?
YES
NO
↑
↓
```

11 When the JOG dial button is pressed, the arrow (cursor) returns to the TITLE1, TITLE2, TITLE3 or TITLE4 item.

```
< INITIALIZE >
READ FACTORY DATA
WRITE USER DATA
SCENE SEL      :1
READ
WRITE
RESET
→ TITLE1:*****
TITLE2:
TITLE3:
TITLE4:
```

14 Turn the JOG dial button to move the arrow (cursor) to YES, and press the JOG dial button. The data settings and title are saved in the scene file area of the camera’s memory.

<Note>

The setting is not effective if the unit is transferred to a different menu or if the menu is exited without executing “WRITE.”

12 Turn the JOG dial button to move the arrow (cursor) to the WRITE item.

```
< INITIALIZE >
READ FACTORY DATA
WRITE USER DATA
SCENE SEL      :1
READ
→ WRITE
RESET

TITLE1:*****
TITLE2:
TITLE3:
TITLE4:
```

15 After the data has been saved, press the MENU button twice.

The setting menu is cleared, and the displays showing the unit’s current statuses appear at the top and bottom of the viewfinder screen.

How to use the scene file

Loading the scene file

1 Perform the menu operations (pages 86 to 88), and display the “INITIALIZE” screen of FILM (CAM) MAIN MENU 4.

```
→< INITIALIZE >
READ FACTORY DATA
WRITE USER DATA
SCENE SEL      :1
READ
WRITE
RESET

TITLE1:
TITLE2:
TITLE3:
TITLE4:
```

2 Turn the JOG dial button to move the arrow (cursor) to the SCENE SEL item.

3 When the JOG dial button is pressed, the scene file number starts flashing. Turn the JOG dial button to select the scene file whose data is to be loaded.

```
< INITIALIZE >
READ FACTORY DATA
WRITE USER DATA
→ SCENE SEL      :1
READ
WRITE
RESET

TITLE1:
TITLE2:
TITLE3:
TITLE4:
```

4 Press the JOG dial button to enter the scene file.

5 Turn the JOG dial button to move the arrow (cursor) to the READ item.

```
< INITIALIZE >
READ FACTORY DATA
WRITE USER DATA
SCENE SEL      :2
→ READ
WRITE
RESET

TITLE1:
TITLE2:
TITLE3:
TITLE4:
```

6 When the JOG dial button is pressed, the following message appears.

```
READ ?
YES
→ NO
```

7 Turn the JOG dial button to move the arrow (cursor) to YES, and press the JOG dial button. The data settings saved in the scene file area of the camera’s memory are loaded, and the settings are completed.

8 Press the MENU button twice. The setting menu is cleared, and the displays showing the unit’s current statuses appear at the top and bottom of the viewfinder screen.

How to use the scene file

Resetting the scene file

1 Perform the menu operations (pages 86 to 88), and display the “INITIALIZE” screen of FILM (CAM) MAIN MENU 4.

```
→< INITIALIZE >
READ FACTORY DATA
WRITE USER DATA
SCENE SEL      :1
  READ
  WRITE
  RESET
TITLE1:
TITLE2:
TITLE3:
TITLE4:
```

2 Turn the JOG dial button to move the arrow (cursor) to the SCENE SEL item.

3 When the JOG dial button is pressed, the scene file number starts flashing. Turn the JOG dial button to select the scene file whose data is to be reset.

```
< INITIALIZE >
READ FACTORY DATA
WRITE USER DATA
→ SCENE SEL      :1
  READ
  WRITE
  RESET
TITLE1:
TITLE2:
TITLE3:
TITLE4:
```

4 Press the JOG dial button to enter the scene file.

5 Turn the JOG dial button to move the arrow (cursor) to the RESET item.

```
< INITIALIZE >
READ FACTORY DATA
WRITE USER DATA
SCENE SEL      :2
  READ
  WRITE
→ RESET
TITLE1:
TITLE2:
TITLE3:
TITLE4:
```

6 When the JOG dial button is pressed, the following message appears.

```
RESET ?
  YES
→ NO
```

7 Turn the JOG dial button to move the arrow (cursor) to YES, and press the JOG dial button. The data saved in the scene file area of the camera’s memory is reset and restored to the factory shipment status.

8 Press the MENU button twice. The setting menu is cleared, and the displays showing the unit’s current statuses appear at the top and bottom of the viewfinder screen.

Setup card operations

Use of the setup memory card (optional accessory) enables the setting menu contents to be saved. Use of this data speeds up the process of reproducing suitable setup statuses.

- The multimedia cards or the SD memory cards can be used as the setup cards.

How to insert the setup card

With the surface bearing the logo facing you, insert the setup card into the setup card slot, and close the cover.

<Note>

Check that the surface bearing the logo is facing you and the lettering is not upside down before inserting the card.

When inserting the card, check the direction in which the card is pointing, and if it does not slide neatly into place, it means that the card may be pointing in the wrong direction or that it may be upside down. Do not force the card into place but check which is the front and back and which is the top and bottom, and try inserting the card again.

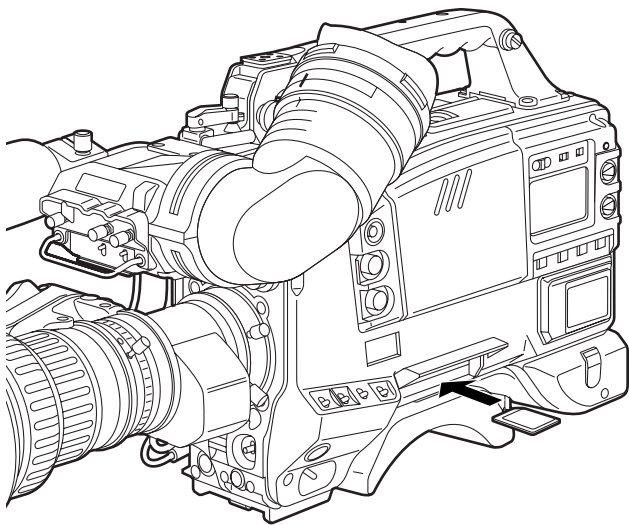

How to eject the setup card

Open the cover by raising its bottom edge, and eject the setup card.

<Note>

Take care not to touch the connector on the edge of the setup card directly.

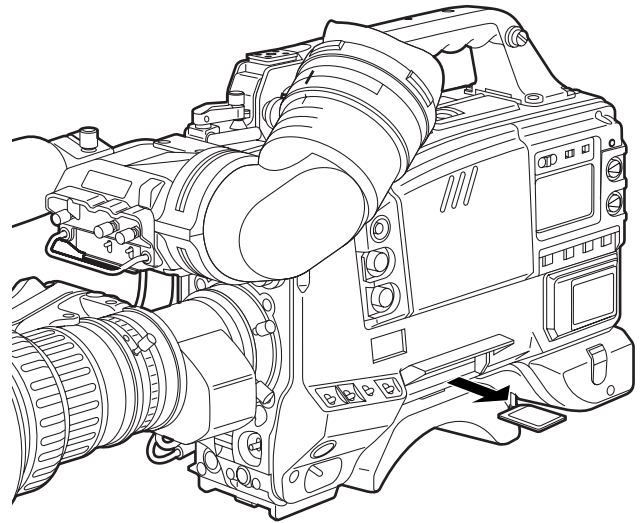

Bear in mind the following points when using and saving the setup cards.

- Avoid high temperatures and high humidity levels.
- Keep the cards away from water.
- Avoid exposing the cards to electrical charges.

Keep the setup card inside the unit with the cover closed.

Setup card operations

The operations for saving setting data on the setup card and loading the saved data from the card are performed on the CAM CARD READ/WRITE screen of FILM (CAM) MAIN MENU 3.

Formatting the setup card

1 Perform the menu operations (pages 86 to 88), and display the “CAM CARD READ/WRITE” screen.

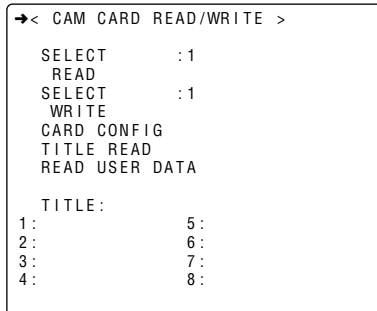

2 Turn the JOG dial button to move the arrow (cursor) to the CARD CONFIG item.

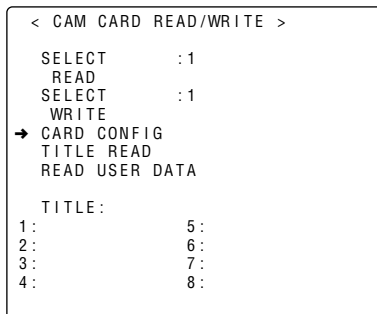

3 When the JOG dial button is pressed, the following message appears on the screen.

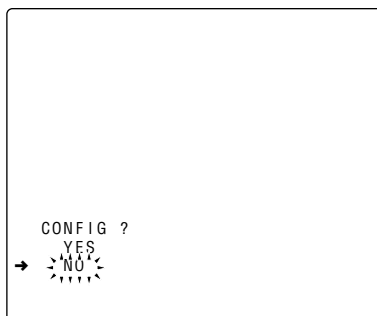

4 To proceed with the formatting of the setup card, turn the JOG dial button to move the arrow (cursor) to YES, and press the JOG dial button. When the formatting of the card is completed, the following message appears.

<Note>

When the card is formatted, the settings statuses applying at the time are also saved in the memory.



If one of the following messages appears when the JOG dial button is pressed, the card will not be formatted.

Error message	Remedial action
CONFIG NG NO CARD (setup card has not been inserted)	Insert the card.
CONFIG NG ERROR (the card cannot be formatted)	The card may be defective. Replace it.

5 Press the MENU button to exit the menu operations.

The setting menu is cleared, and the displays showing the unit’s current statuses appear at the top and bottom of the viewfinder screen.

<Note>

Data titles cannot be recognized when the setup card was inserted while the CAM CARD READ/WRITE screen was open. Move the arrow (cursor) to the TITLE READ item, and press the JOG dial button.

The data title is recognized, and the title is displayed.

Setup card operations

Saving the data settings on the card

1 Perform the menu operations (pages 86 to 88), and display the “CAM CARD READ/WRITE” screen.

```
→< CAM CARD READ/WRITE >
SELECT      :1
READ
SELECT      :1
WRITE
CARD CONFIG
TITLE READ
READ USER DATA

TITLE:
1:          5:
2:          6:
3:          7:
4:          8:
```

Select the file No.

2 Turn the JOG dial button to move the arrow (cursor) to the SELECT item which comes above WRITE, and press the JOG dial button.

```
< CAM CARD READ/WRITE >
SELECT      :1
READ
→ SELECT    :1
WRITE
CARD CONFIG
TITLE READ
READ USER DATA

TITLE:
1:          5:
2:          6:
3:          7:
4:          8:
```

3 Turn the JOG dial button to select a number from 1 to 8, and press the JOG dial button.

Give a title to the selected file.

4 Turn the JOG dial button to move the arrow (cursor) to the “TITLE :” item.

```
< CAM CARD READ/WRITE >
SELECT      :1
READ
SELECT      :1
WRITE
CARD CONFIG
TITLE READ
READ USER DATA

→ TITLE:
1:          5:
2:          6:
3:          7:
4:          8:
```

5 When the JOG dial button is pressed, the arrow (cursor) moves to the title input area, and the input mode is established.

```
< CAM CARD READ/WRITE >
SELECT      :1
READ
SELECT      :1
WRITE
CARD CONFIG
TITLE READ
READ USER DATA

TITLE:
↓
1:          5:
2:          6:
3:          7:
4:          8:
```

6 Press the JOG dial button again and turn it until the character to be set is displayed.

When the button is turned, the character displayed is switched in the following sequence:

- Space:
- ↓
- letters: A—Z
- ↓
- numbers: 0—9
- ↓
- symbols: ' , > , < , / , -

7 Press the JOG dial button to enter the character.

8 Turn the JOG dial button to move the arrow (cursor) to the next position (right), and repeat steps **6** and **7** to set the characters (maximum of 8).

Setup card operations

Saving the data settings to the selected file.

9 When the title has been input, turn the JOG dial button to move the arrow (cursor) to the “:” position.

```

< CAM CARD READ/WRITE >
SELECT      :1
  READ
SELECT      :1
  WRITE
CARD CONFIG
TITLE READ
READ USER DATA
  ↓
TITLE:*****
1:          5:
2:          6:
3:          7:
4:          8:
    
```

10 When the JOG dial button is pressed, the arrow (cursor) returns to the TITLE: item.

```

< CAM CARD READ/WRITE >
SELECT      :1
  READ
SELECT      :1
  WRITE
CARD CONFIG
TITLE READ
READ USER DATA
→ TITLE:*****
1:          5:
2:          6:
3:          7:
4:          8:
    
```

11 Turn the JOG dial button to move the arrow (cursor) to the WRITE item.

```

< CAM CARD READ/WRITE >
SELECT      :1
  READ
SELECT      :1
→  WRITE
CARD CONFIG
TITLE READ
READ USER DATA

TITLE:*****
1:          5:
2:          6:
3:          7:
4:          8:
    
```

12 When the JOG dial button is pressed, the following message appears.

```

WRITE ?
  YES
→ NO
  TITLE *****
    
```

13 Turn the JOG dial button to move the arrow (cursor) to YES, and press the JOG dial button. When the data saving is completed, the following message appears.

```

WRITE OK

TITLE *****
    
```

To save the VTR unit's data, open the VTR CARD READ/WRITE screen, and perform steps **11** to **13**.

If one of the following messages appears when the JOG dial button is pressed, the data cannot be saved.

Error message	Remedial action
WRITE NG NO CARD (setup card has not been inserted)	Insert the card.
WRITE NG FORMAT ERROR (formatting error)	The card was formatted by a device other than the unit. Replace the card.
WRITE NG ERROR (the data cannot be saved)	The card may be defective. Replace it.

14 Press the MENU button to exit the menu operations. The setting menu is cleared, and the displays showing the unit's current statuses appear at the top and bottom of the viewfinder screen.

Setup card operations

Loading the data saved on the card

1 Perform the menu operations (pages 86 to 88), and display the “CAM CARD READ/WRITE” screen.

```
→< CAM CARD READ/WRITE >
SELECT      :1
READ
SELECT      :1
WRITE
CARD CONFIG
TITLE READ
READ USER DATA

TITLE:
1:          5:
2:          6:
3:          7:
4:          8:
```

If the data is given a title when it is saved, the title will also be displayed.

<Note>

“F_” appears in front of a title which was set in the film mode; “V_” appears in front of a title which was set in the video mode. When the data has been loaded, the unit is set to the operation mode of the loaded data.

Select the file No.

2 Turn the JOG dial button to move the arrow (cursor) to the SELECT item which comes above READ, and press the JOG dial button.

```
< CAM CARD READ/WRITE >
→ SELECT      :1
READ
SELECT      :1
WRITE
CARD CONFIG
TITLE READ
READ USER DATA

TITLE:
1:          5:
2:          6:
3:          7:
4:          8:
```

3 Turn the JOG dial button to select any number from 1 to 8, and press the JOG dial button.

Load the data of the selected file.

4 Turn the JOG dial button to move the arrow (cursor) to the READ item.

```
< CAM CARD READ/WRITE >
SELECT      :1
→ READ
SELECT      :1
WRITE
CARD CONFIG
TITLE READ
READ USER DATA

TITLE:
1:          5:
2:          6:
3:          7:
4:          8:
```

5 When the JOG dial button is pressed, the following message appears.

```
READ ?
YES
→ NO
```

6 Turn the JOG dial button to move the arrow (cursor) to YES, and press the JOG dial button. When the data loading is completed, the following message appears.

```
READ OK

TITLE      :*****
```

To load the VTR unit’s data, open the VTR CARD READ/WRITE screen, and perform steps **4** to **6**.

Setup card operations

If one of the following messages appears when the JOG dial button is pressed, the data cannot be loaded.

Error message	Remedial action
READ NG NO CARD (setup card has not been inserted)	Insert the card.
READ NG FORMAT ERROR (formatting error)	The card was formatted by a device other than the unit. Replace the card.
READ NG NO FILE (file not found)	Save the file data.
READ NG ERROR (the data cannot be loaded)	Data saved by devices other than unit cannot be loaded.

7 Press the MENU button to exit the menu operations.

The setting menu is cleared, and the displays showing the unit's current statuses appear at the top and bottom of the viewfinder screen.

Cassette tapes

Loading a cassette tape

1 Check that there are no cables around the cassette holder or top panel, and set the POWER switch to ON.

<Note>

When condensation has formed inside the unit, the HUMID display lights. Wait until this display is cleared before proceeding with the intended operation.

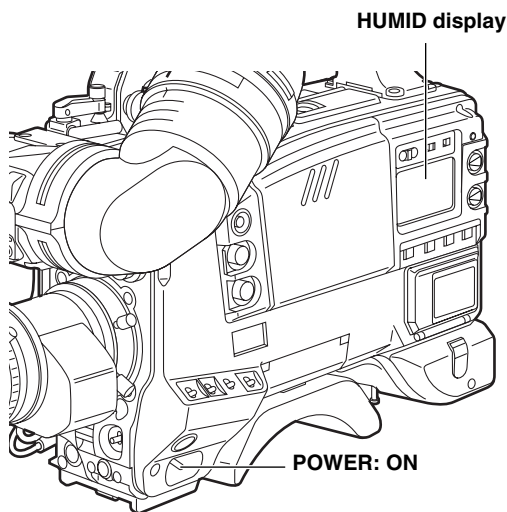

2 Press the EJECT button. The cassette holder opens.

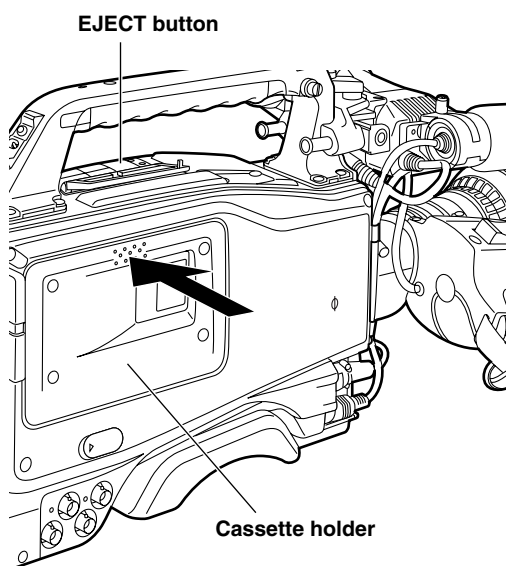

3 Insert the cassette tape and press the part marked with the arrow to close the cassette holder securely.

<Note>

Check that there is no slack in the tape of the cassette.

Checking for tape slack

Gently push in the reel using your finger and turn the reel in the direction of the arrow. If the reel fails to turn, it means there is no tape slack.

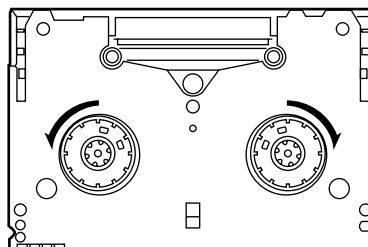

Ejecting the cassette tape

While the power is still on, press the EJECT button to open the cassette holder, and take out the cassette tape. If another cassette is not going to be loaded immediately after this tape is ejected, close the cassette holder.

Ejecting the cassette when the battery has no charge

First, set the POWER switch to OFF to turn off the unit's power.

Then turn the power back on, and immediately hold down the EJECT button.

The cassette can be removed when there is still some power left in the battery. However, do not repeat this operation.

To prevent accidental erasure

Set the cassette's tab to SAVE to prevent the recordings on the tape from being erased accidentally.

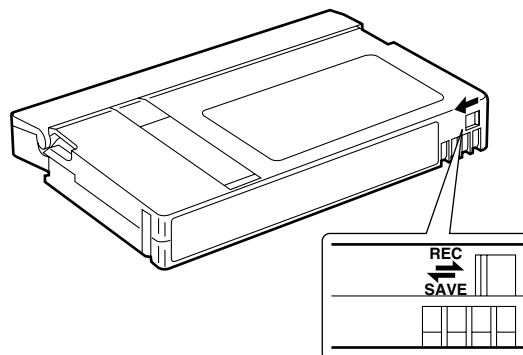

Recording

This section describes the basic steps for shooting and recording.

Before actually departing to shoot scenes, carry out inspections to ensure that the system is functioning properly.

- For details on how to perform these inspections, refer to “Inspections prior to shooting” (pages 128 to 131).

From providing the power supply to loading the cassette

- 1** Install a fully charged battery pack.
- 2** Set the POWER switch to ON. Now check that the HUMID display is not showing and that at least 5 segments of the remaining battery charge display are lit.
 - If the HUMID display is showing, wait until it goes off.
 - If at least 5 segments of the remaining battery charge display are not lit, replace the battery with a fully charged one.
- 3** Check that there are no cables around the cassette holder or top panel, and then press the EJECT button to open the cassette holder.
- 4** After checking the following, insert the cassette tape, and close the cassette holder.
 - Position of the accidental erasure prevent tab
 - Tape slack

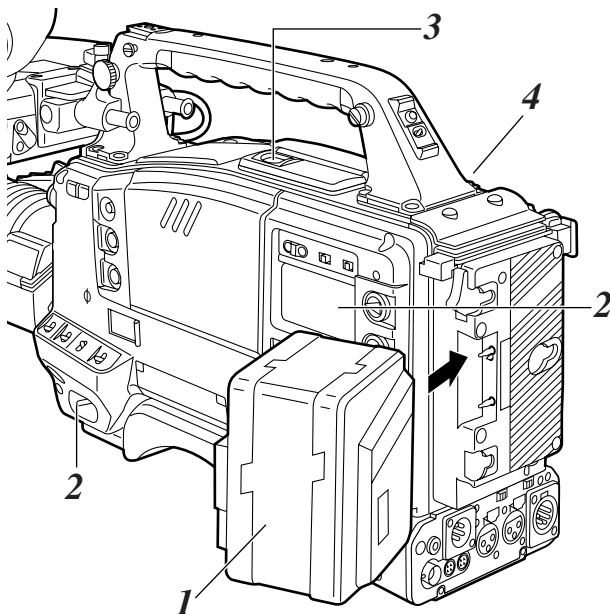

From adjusting the white balance and black balance to stopping the recording

Turn on the power, and after inserting the cassette, set the switches as shown in the figure below.

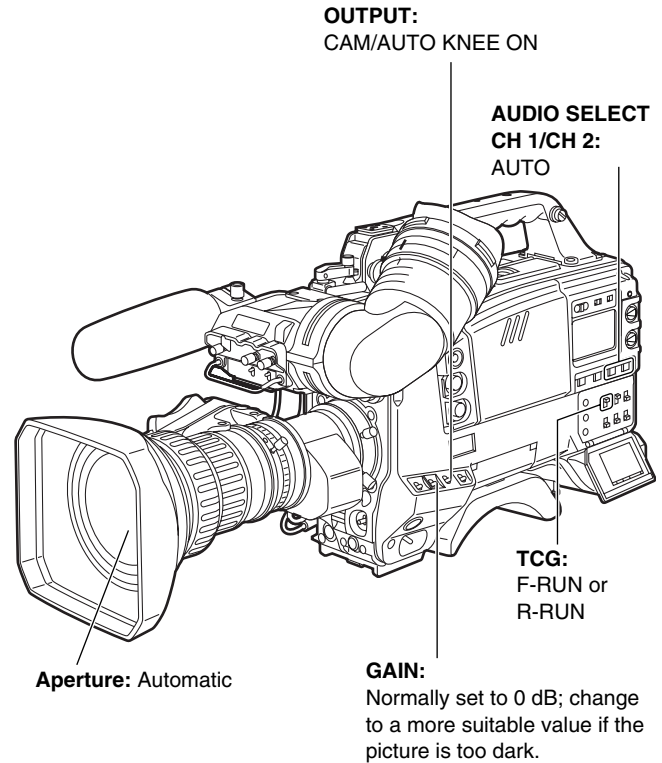

Recording

Shooting

- 1-1** Select the filter to match the lighting conditions, and set the WHITE BAL switch to “A” or “B” if the white balance has been stored in the memory ahead of time.

If the white balance and/or black balance have not been stored in the memory and there is no time to adjust the white balance: Set the WHITE BAL switch to PRST. The white balance for the filter is achieved in accordance with the setting position of the FILTER control (outer).

- 1-2** When adjusting the white balance on the spot

Select the filter to match the lighting conditions, set the WHITE BAL switch to “A” or “B,” and adjust the white balance as follows:

- (1) Press the AUTO W/B BAL switch to the AWB position and adjust the white balance.
- (2) Press the AUTO W/B BAL switch to the ABB position and adjust the black balance.
- (3) Press the AUTO W/B BAL switch to the AWB position and adjust the white balance again.

For details on how to adjust the white balance, refer to “Adjusting the white balance and black balance” (pages 53 to 57).

- 2** Point the camera at the subject, and adjust the focus and zoom.

- 3** When the electronic shutter is to be used, set the shutter speed and operating mode.
- For details, refer to “Setting the electronic shutter” (pages 58 to 60).

- 4** Press the VTR START button or lens VTR button to start recording.
- During recording, the REC lamp inside the viewfinder lights.

- 5** To stop the recording, press the VTR START button again.
- The REC lamp inside the viewfinder goes off.

Tape function buttons

During recording, the tape function buttons (EJECT, REW, FF, PLAY/PAUSE and STOP) will not work.

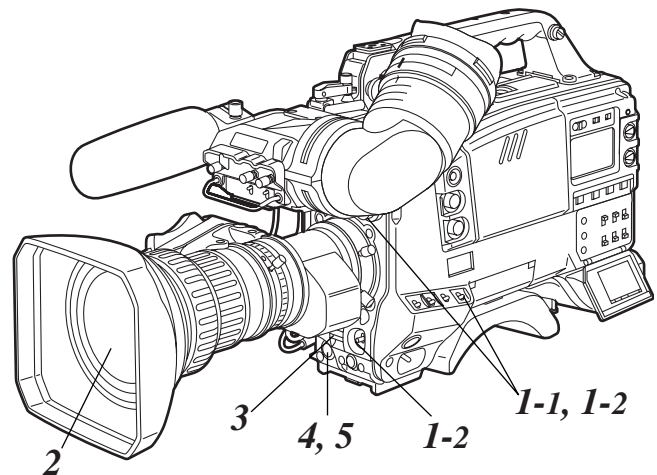

Scene-to-scene continuity

If the unit is in the rec-pause mode, it is possible to ensure scene-to-scene continuity with an accuracy of 0 up to 1 frame just by pressing the VTR START button or lens VTR button.

If the unit is in a mode other than rec-pause, the point at which the scene-to-scene continuity is to be maintained must be located before recording is started.

During rec-pause

The scene-to-scene continuity timing is located automatically. However, the time taken until the start of recording differs depending on the setting of the VTR SAVE/STBY switch.

- When the VTR SAVE/STBY switch is set to SAVE, recording commences about two seconds after the VTR START button is pressed.
- When the VTR SAVE/STBY switch is set to STBY, recording commences as soon as the VTR START button is pressed.

Ensuring scene-to-scene continuity after the power was turned off while the unit was in the rec-pause mode

- 1 Switch the power back on.
- 2 Press the VTR START button or lens VTR button to start the recording.

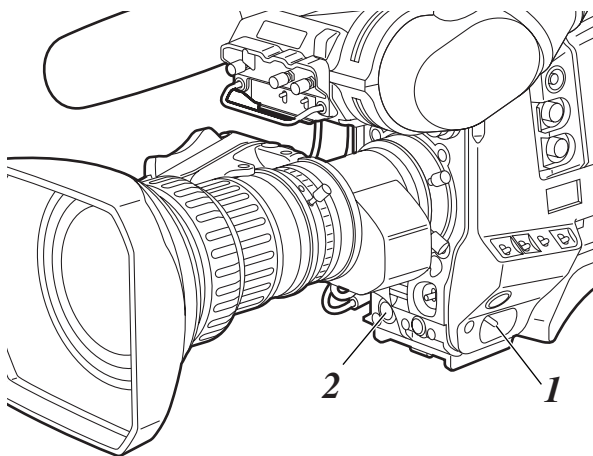

Ensuring scene-to-scene continuity at other times

Proceed as follows either after the tape has been allowed to run or after the cassette has been ejected or when ensuring continuity on a tape which has been recorded only in part.

- 1 While monitoring the viewfinder screen, press the PLAY/PAUSE button to play back the tape.
- 2 At the place on the tape where continuity is to be maintained, press the PLAY/PAUSE (or STOP) button again to stop the tape.
- 3 Press the lens RET button. It takes about two seconds to complete the preparations for the scene-to-scene continuity.
- 4 Press the VTR START button or lens VTR button to start the recording.

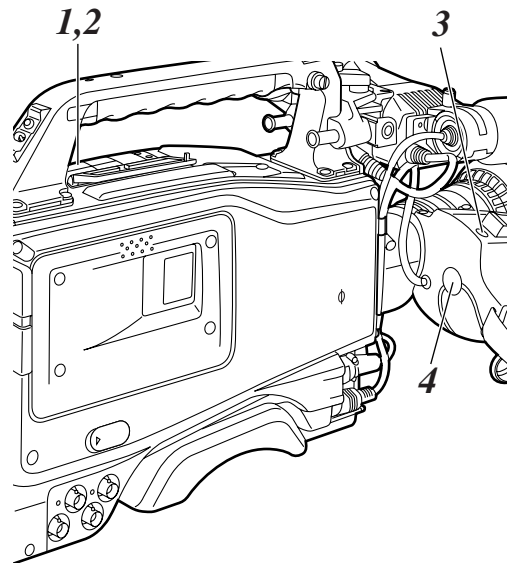

The functions of a VTR START/STOP button can be assigned to the USER1 or USER2 button on the unit's side panel on the CAM SW MODE screen of FILM (CAM) MAIN MENU 2, and this button can then be used to perform the start and stop operations.

Playback (checking what has been recorded)

When the PLAY/PAUSE button is pressed, the playback pictures can be monitored in black and white on the viewfinder screen.

These playback pictures can be monitored in two other ways.

Rec review

When recording is temporarily stopped and the lens RET button is pressed, the last two seconds of the tape are automatically rewound, and the playback pictures on this part of the tape appear on the viewfinder screen. This makes it possible to check whether recording was performed properly.

After the two seconds of the tape have been played back, the unit is again set to the recording start standby mode.

If the RET button is held down, a maximum of 10 seconds of the tape is rewound and played back.

<Note>

The rec review function cannot be used unless recording lasts for one or more seconds.

The functions of the RET button on the lens can be assigned to the USER1 or USER2 button on the unit's side panel on the CAM SW MODE screen of FILM (CAM) MAIN MENU 2, and this button can then be used to perform the return operations.

Colour playback

When an HD colour monitor is connected to the unit's HD SDI OUT connector, colour playback pictures can be monitored.

The playback signals will be output to the viewfinder even during rewinding (REW) or fast forwarding (FF).

Selecting the audio output of the playback signal and adjusting the volume are accomplished using the MONITOR switch control (page 13).

Lens RET button functions

Depending on the internal VTR status, the RET button functions which appear on the viewfinder screen change as follows.

Internal VTR status	What appears on the viewfinder screen
During recording	Pictures which are shot by the camera (RET button does not work)
During rec-pause	What has just been recorded (rec review of 2 seconds of the tape recording) can be checked.
During playback	Playback pictures of internal VTR (RET button does not work)
During play-pause	Pictures accompanying operation to locate the scene-to-scene continuity point

The functions of the RET button on the lens can be assigned to the USER1 or USER2 button on the unit's side panel on the CAM SW MODE screen of FILM (CAM) MAIN MENU 2, and this button can then be used to perform the return operations.

Other VTR functions

NEWS REC function

The NEWS REC function is set using NEWS REC MODE on the VTR MENU “FUNCTION” screen.

By controlling the VTR START button acknowledgment time during recording (by up to 2 seconds), the time taken for the unit to transfer from the recording mode to the rec-pause mode can be delayed.

In other words, by controlling the VTR START button operation acknowledgment time, the unit can continuously record without the user having to interrupt the recording: this safeguards against the failure to record those precious moments—a failure that occurs when recording is resumed immediately after it was shut down temporarily.

RETAKE function

The RETAKE function is activated by selecting ON for RETAKE MODE on the VTR MENU “FUNCTION” screen.

If the lens RET button is pressed while holding down the MODE CHECK button when the unit is in the rec-pause mode upon completion of a recording or subsequently in the STOP mode, the tape will be rewound to a point near the start point (a position about 10 frames ahead of the recording start point) of the final picture which was last recorded, and the unit will be set to the rec-pause mode.

If there is enough leeway in the shooting time and a particular cut is clearly judged to be no good, recording can be started from that point so that the no-good cut will be deleted.

By cutting down on the time taken for copying onto the work tape, for instance, this function is very effective in achieving economical operation.

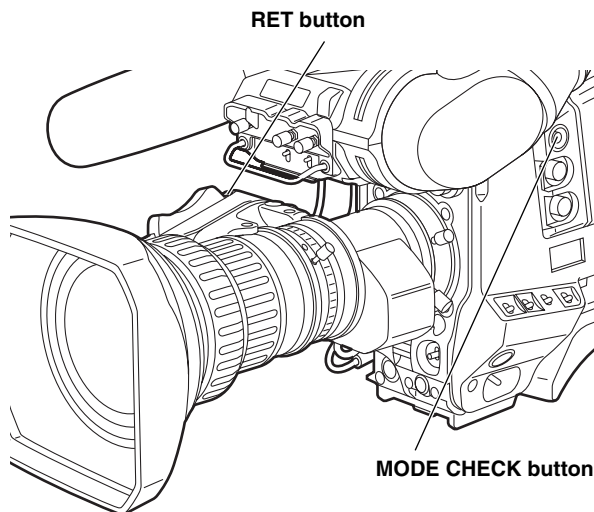

INTERVAL REC (intermittent recording) function

This function makes simple interval shooting (intermittent recording) possible. It proves to be particularly effective when shooting programmes with a nature theme or art programmes.

The INTERVAL REC function is set on the VTR MENU “FUNCTION” screen.

- INTERVAL REC MODE
This sets the INTERVAL REC function to ON, ONE SHOT or OFF.
- INTERVAL REC TIME
This sets the recording time (1 cut) for interval shooting.
- INTERVAL PAUSE TIME
This sets the rec-pause time for interval shooting.

Once the above items are set, the unit is set to the INTERVAL REC mode, and “i” starts to flash inside the viewfinder.

When the VTR START button is now pressed, interval shooting is started, and “iREC” lights in place of “i.” Also, the time unit (h/min/s/frm) display on the counter display area starts to flash.

When the unit is set to rec-pause mode upon completion of the first interval shooting, “iREC” goes from lit to flashing inside the viewfinder.

The time unit display on the counter display area remains flashing.

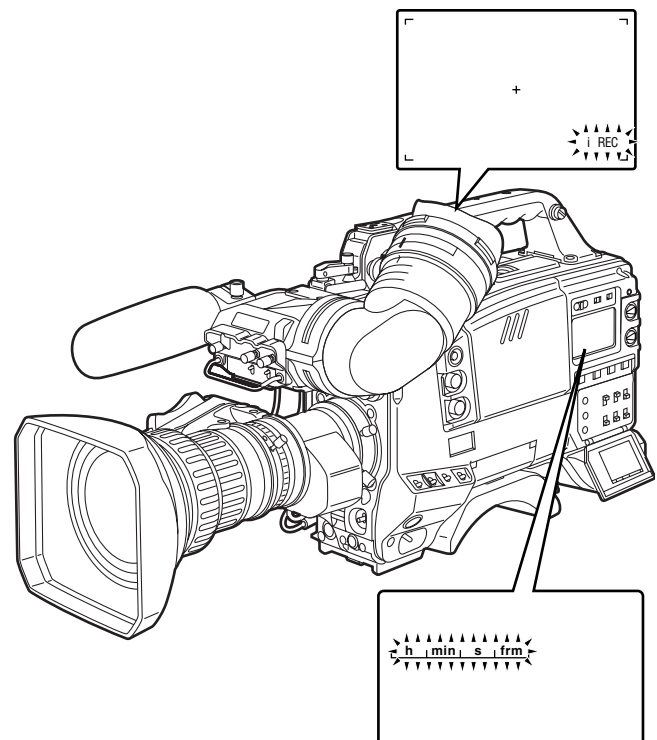

Menu operations

The setting menu operations are performed using the MENU button and JOG dial button. The menu configuration is divided into the camera unit's setting menus and VTR unit's setting menus.

It is possible to select the engineer menu which enables all the setting menu items to be set or, alternatively, the user menu which consists of individually tailored menus so that only those menus which will be used most frequently can be set.

User menu

The user menu was set when the unit was shipped. However, the user can change the configuration of the menus by selecting only those menus which will be used most frequently so that they will be tailored to the user's individual needs.

Set the user menu on the USER MENU SELECT 1, 2, and 3 screen of the engineer menu. The data settings are saved in the non-volatile memory for long-term storage. The menu settings performed in the film mode and video mode are saved separately.

Display method

- When the MENU button is pressed, the camera unit's USER menu screen which was set at the time of shipment is displayed.
- When the MENU button is pressed again, the VTR unit's USER menu screen is displayed.
- When the MENU button is pressed once more, the menu screen display is cleared.

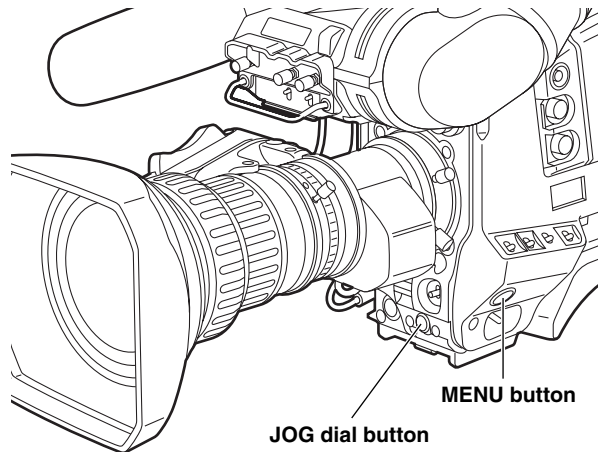
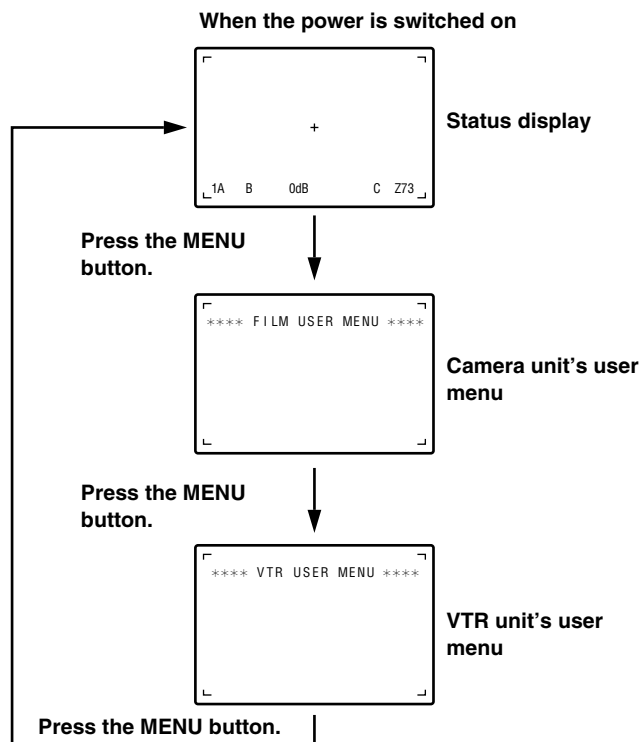

Engineer menu

All the setting menu items can be set on this menu. The data settings are saved in the non-volatile memory for long-term storage.

Display method

- Hold down the MENU button for at least 3 seconds.
- When the MENU button is pressed again, the VTR unit's MAIN MENU screen is displayed.
- When the MENU button is pressed once more, the menu screen display is cleared.

<Note>

The engineer menu is displayed at all times when the AJ-EC3 extension control unit (optional accessory) is connected to the unit for operating the unit by remote control.

Film mode and video mode

The unit can be set to the film mode or video mode on the OPTION screen of FILM (CAM) MAIN MENU 4. When VIDEO MENU is selected as the CAM MENU SEL setting on the OPTION screen, the FILM USER MENU and FILM MAIN MENU displays change to the CAM USER MENU and CAM MAIN MENU. The menu settings performed in the film mode and video mode are saved separately.

Menu operations

Basic setting menu operations

Displaying menus

User menu:

- 1 Press the MENU button.
The camera unit's USER menu screen is displayed.
- 2 When the MENU button is pressed again, the VTR unit's USER menu screen is displayed.

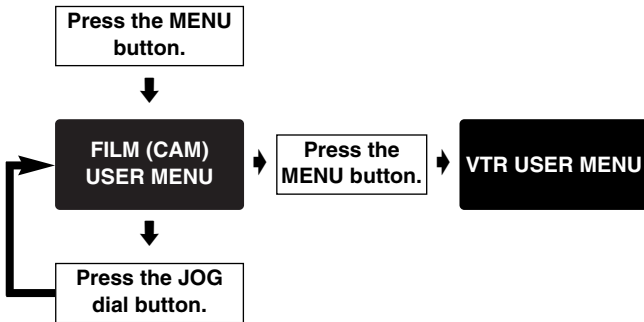

Engineer menu:

- 1 Hold down the MENU button for at least 3 seconds.
- 2 When the JOG dial button is pressed, the next MAIN menu screen (of the camera unit) is displayed.
- 3 When the MENU button is pressed, the VTR unit's MAIN MENU screen is displayed.

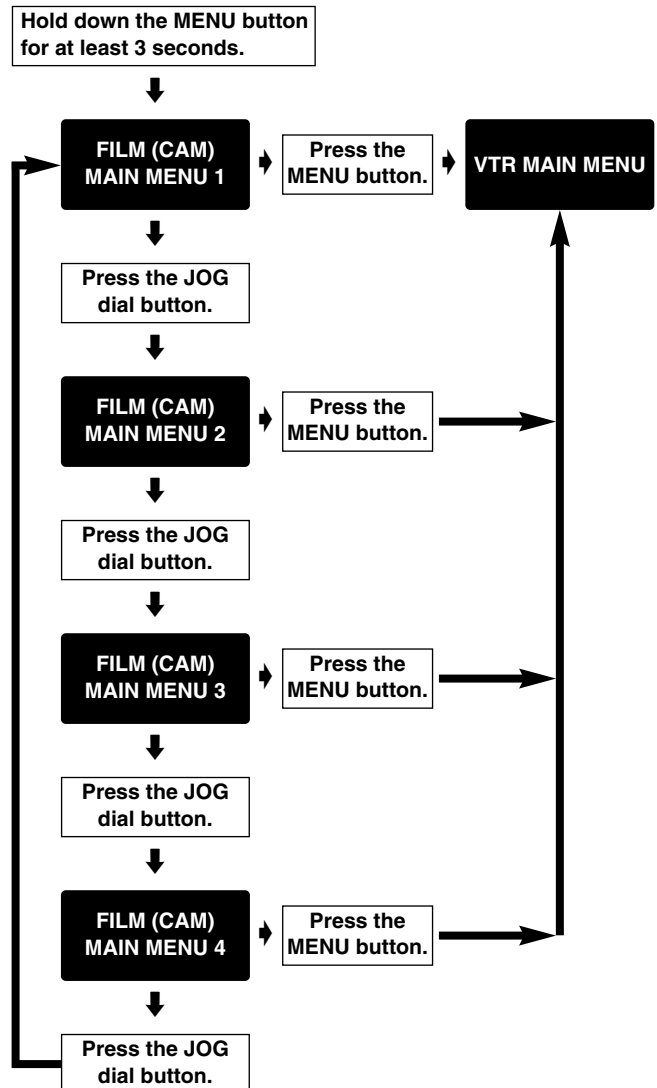

Menu operations

Displaying sub-menus and deciding on settings

Operations common to the user menu and engineer menu

1 Turn the JOG dial button while the USER menu screen or MAIN menu screen is displayed. The cursor (→) moves to the SUB menu item.

Example:

Turn the JOG dial button. →

```
→ **** FILM MAIN MENU1 ****
ROP
MATRIX
COLOR CORRECTION1
COLOR CORRECTION2
LOW SETTING
MID SETTING
HIGH SETTING
ADDITIONAL DTL1
ADDITIONAL DTL2
SKIN TONE DTL
KNEE/LEVEL
GAMMA
CAMERA SETTING
```

2 Move the cursor (→) to the desired SUB menu item, and press the JOG dial button. The SUB menu is now displayed. (The cursor appears in the title part of the SUB menu.)

Example:

Press the JOG dial button. →

```
**** FILM MAIN MENU1 ****
→ ROP
MATRIX
COLOR CORRECTION1
COLOR CORRECTION2
LOW SETTING
MID SETTING
HIGH SETTING
ADDITIONAL DTL1
ADDITIONAL DTL2
SKIN TONE DTL
KNEE/LEVEL
GAMMA
CAMERA SETTING
```

→< ROP >

```
MASTER PED      : +000
MASTER DTL      : +00
MASTER GAMMA    : 0.45
R GAIN          : +000
G GAIN          : +000
B GAIN          : +000
R PEDESTAL     : +000
G PEDESTAL     : +000
B PEDESTAL     : +000
```

3 Turn the JOG dial button to move the cursor to the desired item to be set, and press the JOG dial button.

The digit whose value is to be set now flashes.

Example:

Press the JOG dial button. →

```
< ROP >
→ MASTER PED      : +000
MASTER DTL      : +00
MASTER GAMMA    : 0.45
R GAIN          : +000
G GAIN          : +000
B GAIN          : +000
R PEDESTAL     : +000
G PEDESTAL     : +000
B PEDESTAL     : +000
```

4 Turn the JOG dial button to change the setting.

5 When the desired setting is reached, press the JOG dial button. The setting is now entered.

6 When other items are to be set, turn the JOG dial button to move the cursor, and change and enter the settings by repeating steps **3** to **5**.

7 To move to another SUB menu, turn the JOG dial button to move the cursor to the title part of the SUB menu, and press the JOG dial button. The USER menu screen or MAIN menu screen is now displayed so proceed with operation by following the same steps.

Example:

Press the JOG dial button. →

```
→< ROP >
MASTER PED      : +008
MASTER DTL      : +00
MASTER GAMMA    : 0.45
R GAIN          : +000
G GAIN          : +000
B GAIN          : +000
R PEDESTAL     : +000
G PEDESTAL     : +000
B PEDESTAL     : +000
```

8 Upon completion of the settings, press the MENU button. The settings are now recorded, the setting menu mode is exited, and the normal operation mode is restored.

<Note>

To exit the camera unit's menu, press the MENU button twice. When the MENU button is pressed once, operation is transferred to the VTR unit's menu.

Setting menu configuration

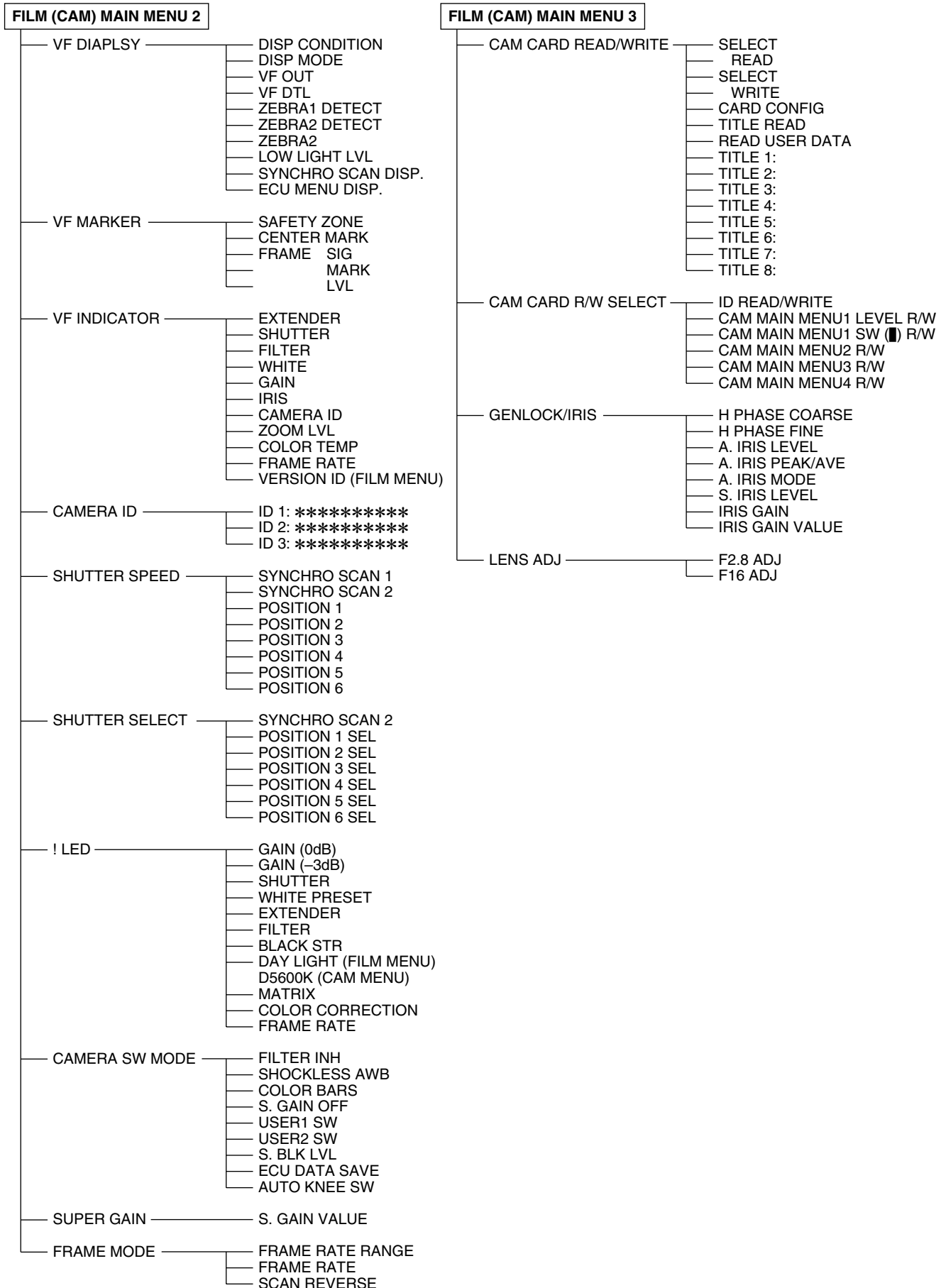

Setting menu configuration

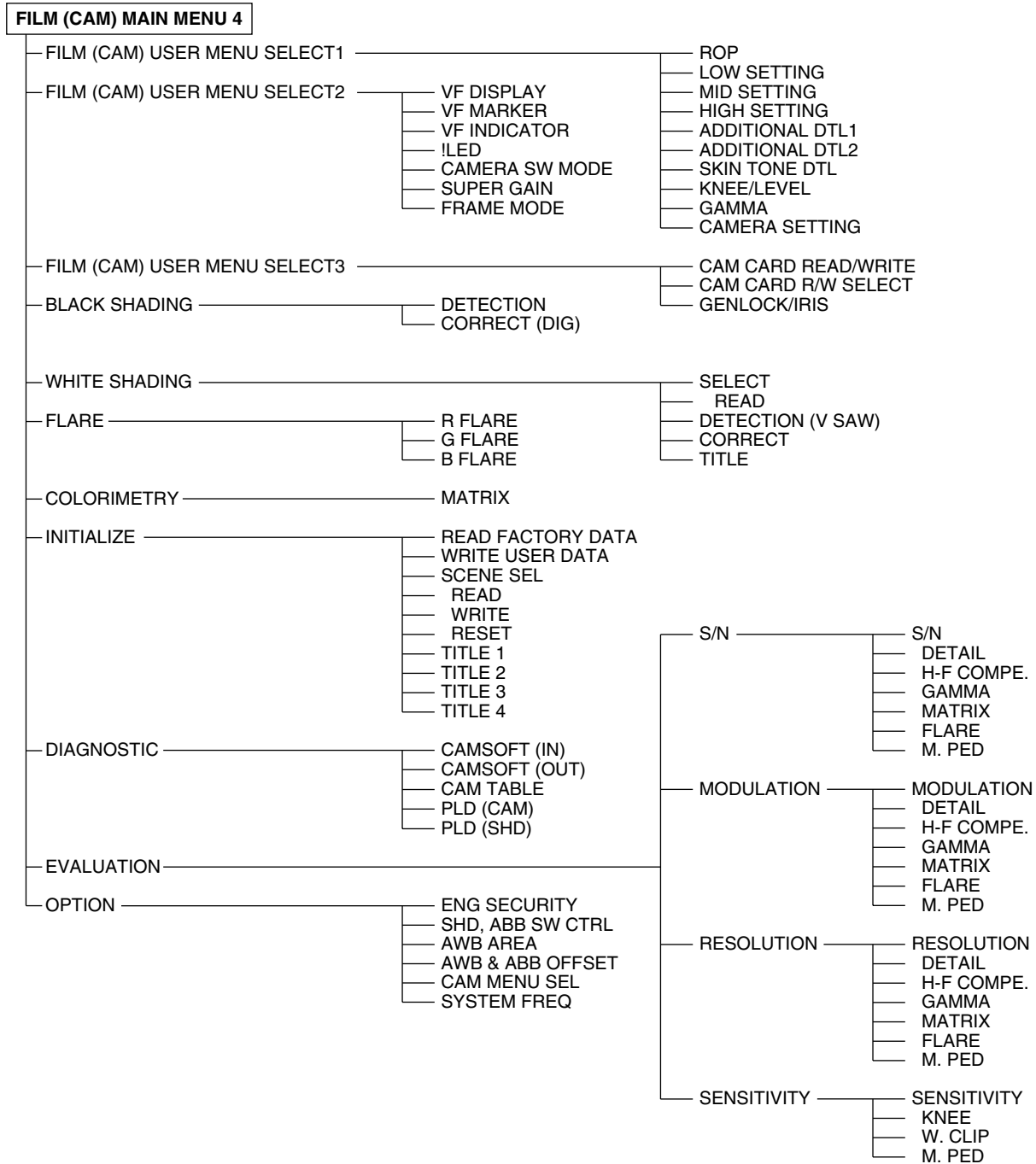

Setting menu configuration

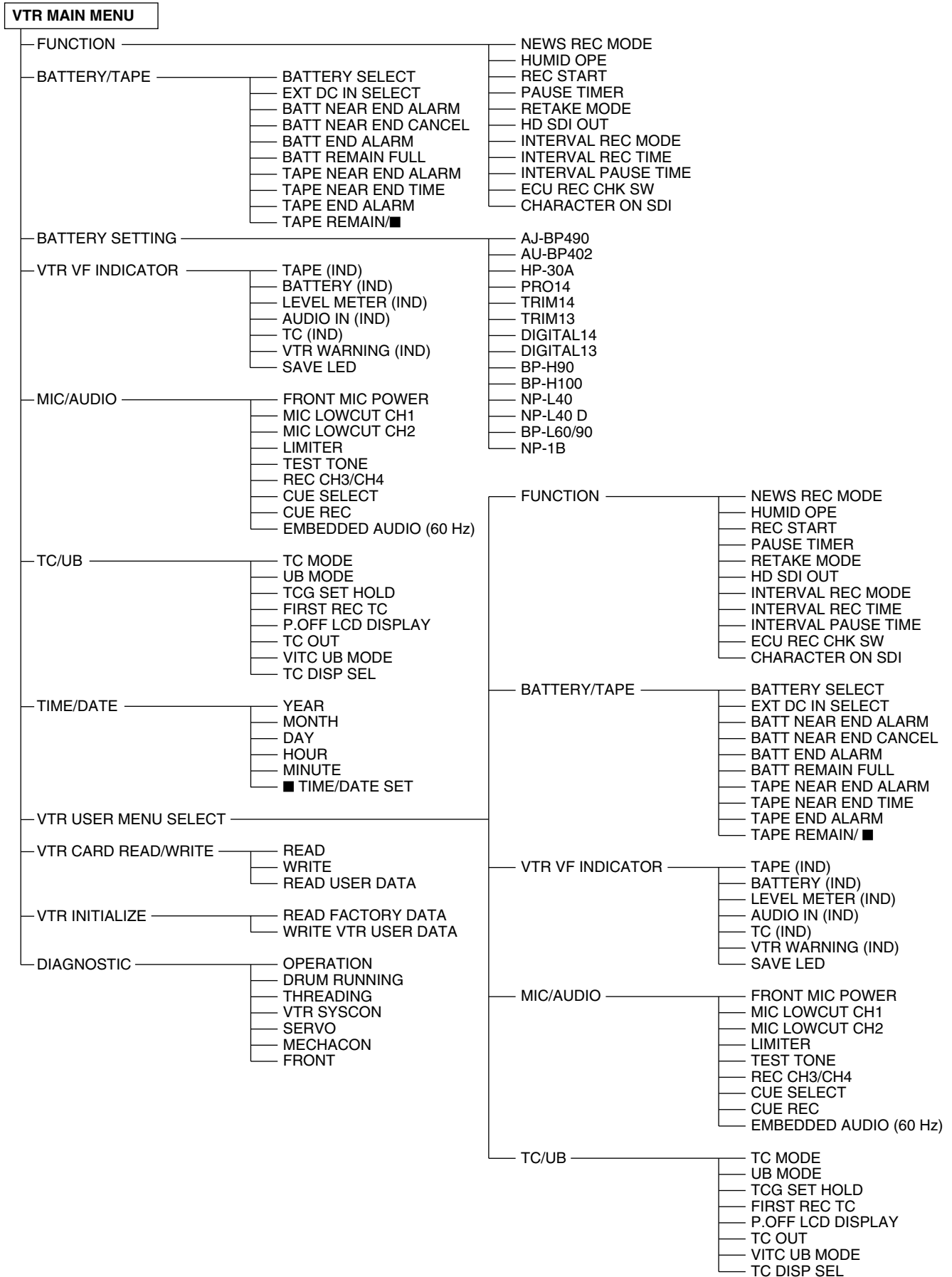

Setting menu screens *FILM (CAM) MENUS*

The main menu consists of FILM (CAM) MAIN MENU (1 to 4) of the camera and the VTR MAIN MENU of the VTR.

These screens are index screens which are used to open the sub-menus.

The setting menu is operated with the MENU button and JOG dial button.

(Refer to pages 86 to 88 for the menu operations.)

FILM (CAM) MAIN MENU 1 screen

SUB menu	VF display	Remarks
ROP	USER ENG	Index for opening the ROP screen.
MATRIX	ENG	Index for opening the MATRIX screen.
COLOR CORRECTION1	ENG	Index for opening the COLOR CORRECTION 1 screen.
COLOR CORRECTION2	ENG	Index for opening the COLOR CORRECTION 2 screen.
LOW SETTING	USER ENG	Index for opening the LOW SETTING screen.
MID SETTING	USER ENG	Index for opening the MID SETTING screen.
HIGH SETTING	USER ENG	Index for opening the HIGH SETTING screen.
ADDITIONAL DTL1	USER ENG	Index for opening the ADDITIONAL DTL 1 screen.
ADDITIONAL DTL2	USER ENG	Index for opening the ADDITIONAL DTL 2 screen.
SKIN TONE DTL	USER ENG	Index for opening the SKIN TONE DTL screen.
KNEE/LEVEL	USER ENG	Index for opening the KNEE/LEVEL screen.
GAMMA	USER ENG	Index for opening the GAMMA screen.
CAMERA SETTING	USER ENG	Index for opening the CAMERA SETTING screen.

FILM (CAM) MAIN MENU 2 screen

SUB menu	VF display	Remarks
VF DISPLAY	USER ENG	Index for opening the VF DISPLAY screen.
VF MARKER	USER ENG	Index for opening the VF MARKER screen.
VF INDICATOR	USER ENG	Index for opening the VF INDICATOR screen.
CAMERA ID	ENG	Index for opening the CAMERA ID screen.
SHUTTER SPEED	ENG	Index for opening the SHUTTER SPEED screen.
SHUTTER SELECT	ENG	Index for opening the SHUTTER SELECT screen.

FILM (CAM) MAIN MENU 2 screen

SUB menu	VF display	Remarks
!LED	USER ENG	Index for opening the !LED screen.
CAMERA SW MODE	USER ENG	Index for opening the CAMERA SW MODE screen.
SUPER GAIN	USER ENG	Index for opening the SUPER GAIN screen.
FRAME MODE	USER ENG	Index for opening the FRAME MODE screen.

FILM (CAM) MAIN MENU 3 screen

SUB menu	VF display	Remarks
CAM CARD READ/WRITE	USER ENG	Index for opening the CAM CARD READ/WRITE screen.
CAM CARD R/W SELECT	USER ENG	Index for opening the CAM CARD R/W SELECT screen.
GENLOCK/IRIS	USER ENG	Index for opening the GENLOCK/IRIS screen.
LENS ADJ	ENG	Index for opening the LENS ADJ screen.

FILM (CAM) MAIN MENU 4 screen

SUB menu	VF display	Remarks
CAM USER MENU SELECT1	ENG	Index for opening the FILM (CAM) USER MENU SELECT 1 screen.
CAM USER MENU SELECT2	ENG	Index for opening the FILM (CAM) USER MENU SELECT 2 screen.
CAM USER MENU SELECT3	ENG	Index for opening the FILM (CAM) USER MENU SELECT 3 screen.
BLACK SHADING	ENG	Index for opening the BLACK SHADING screen.
WHITE SHADING	ENG	Index for opening the WHITE SHADING screen.
FLARE	ENG	Index for opening the FLARE screen.
COLORIMETRY	ENG	Index for opening the COLORIMETRY screen.
INITIALIZE	ENG	Index for opening the INITIALIZE screen.
DIAGNOSTIC	ENG	Index for opening the DIAGNOSTIC screen.
EVALUATION	ENG	Index for opening the EVALUATION screen.
OPTION	ENG	Index for opening the OPTION screen.

Setting menu screens FILM (CAM) MAIN MENU 1

ROP screen

The ROP (Remote Operation Panel) is set on this screen.

Item	Variable range	VF display	Remarks
MASTER PED (FILM MENU) (CAM MENU)	-200 : <u>0</u> : +18 : +200 (Max.)	USER ENG	MASTER PEDESTAL level setting.
MASTER DTL	-31 : <u>+00</u> : +31	USER ENG	H. DTL/V. DTL level setting.
MASTER GAMMA	0.35 : <u>0.45</u> : 0.75	USER ENG	MASTER GAMMA setting. (0.01 step) Three different values can be stored for LOW, MID and HIGH in the memory.
R GAIN	-200 : <u>+000</u> : +200 (Max.)	USER ENG	For setting R channel gain.
G GAIN	-200 : <u>+000</u> : +200 (Max.)	USER ENG	For setting G channel gain.
B GAIN	-200 : <u>+000</u> : +200 (Max.)	USER ENG	For setting B channel gain.
R PEDESTAL	-100 : <u>+000</u> : +100 (Max.)	USER ENG	For setting R channel PEDESTAL level.
G PEDESTAL	-100 : <u>+000</u> : +100 (Max.)	USER ENG	For setting G channel PEDESTAL level.
B PEDESTAL	-100 : <u>+000</u> : +100 (Max.)	USER ENG	For setting B channel PEDESTAL level.

MATRIX screen

The camera matrix is set on this screen.

Item	Variable range	VF display	Remarks
MATRIX TABLE	<u>A</u> B	ENG	For selecting the colour adjustment display.
MATRIX R-G	-31 : <u>+00</u> : +31	ENG	Colour adjustment
MATRIX R-B	-31 : <u>+00</u> : +31	ENG	Colour adjustment
MATRIX G-R	-31 : <u>+00</u> : +31	ENG	Colour adjustment
MATRIX G-B	-31 : <u>+00</u> : +31	ENG	Colour adjustment
MATRIX B-R	-31 : <u>+00</u> : +31	ENG	Colour adjustment
MATRIX B-G	-31 : <u>+00</u> : +31	ENG	Colour adjustment

<Notes>

- The white balance and black balance will not change even if the MATRIX is changed.
- Two tables, A and B, can be stored in the memory for the MATRIX TABLE item.
- "00" applies for all the preset modes in MATRIX TABLE B.

The underlining in the variable range column indicates the setting in the preset mode.

Setting menu screens *FILM (CAM) MAIN MENU 1*

COLOR CORRECTION 1 screen

The camera colour saturation adjustments and hue adjustments are set on this screen.

Item	Variable range	VF display	Remarks
R (SAT) R (PHASE)	-63 : <u>+00</u> : +63	ENG	Colour saturation adjustment and hue adjustment: red
Mg (SAT) Mg (PHASE)	-63 : <u>+00</u> : +63	ENG	Colour saturation adjustment and hue adjustment: magenta
B (SAT) B (PHASE)	-63 : <u>+00</u> : +63	ENG	Colour saturation adjustment and hue adjustment: blue
Cy (SAT) Cy (PHASE)	-63 : <u>+00</u> : +63	ENG	Colour saturation adjustment and hue adjustment: cyan
G (SAT) G (PHASE)	-63 : <u>+00</u> : +63	ENG	Colour saturation adjustment and hue adjustment: green
YI (SAT) YI (PHASE)	-63 : <u>+00</u> : +63	ENG	Colour saturation adjustment and hue adjustment: yellow

COLOR CORRECTION 2 screen

The camera colour saturation adjustments and hue adjustments are set on this screen.

Item	Variable range	VF display	Remarks
R-Mg (SAT) R-Mg (PHASE)	-63 : <u>+00</u> : +63	ENG	Colour saturation adjustment and hue adjustment: between red and magenta
Mg-B (SAT) Mg-B (PHASE)	-63 : <u>+00</u> : +63	ENG	Colour saturation adjustment and hue adjustment: between magenta and blue
B-Cy (SAT) B-Cy (PHASE)	-63 : <u>+00</u> : +63	ENG	Colour saturation adjustment and hue adjustment: between blue and cyan
Cy-G (SAT) Cy-G (PHASE)	-63 : <u>+00</u> : +63	ENG	Colour saturation adjustment and hue adjustment: between cyan and green
G-YI (SAT) G-YI (PHASE)	-63 : <u>+00</u> : +63	ENG	Colour saturation adjustment and hue adjustment: between green and yellow
YI-R (SAT) YI-R (PHASE)	-63 : <u>+00</u> : +63	ENG	Colour saturation adjustment and hue adjustment: between yellow and red

The underlining in the variable range column indicates the setting in the preset mode.

Setting menu screens FILM (CAM) MAIN MENU 1

LOW SETTING screen

The low level gain is set on this screen.

Item	Variable range	VF display	Remarks
MASTER GAIN (FILM MENU)	-3dB : <u>0dB</u> : 30dB	USER ENG	-3 dB, 0 dB, 3 dB, 6 dB, 9 dB, 12 dB, 18 dB, 24 dB or 30 dB can be set.
(CAM MENU)	-6dB : <u>0dB</u> : 30dB		-6dB, -3 dB, 0 dB, 3 dB, 6 dB, 9 dB, 12 dB, 18 dB, 24 dB or 30 dB can be set.
H. DTL LEVEL (FILM MENU)	0 : <u>8</u> : 12	USER ENG	For setting H.DTL (detail) level.
(CAM MENU)	<u>12</u> : 63		
V. DTL LEVEL (FILM MENU)	0 : <u>12</u> : 16	USER ENG	For setting V.DTL (detail) level.
(CAM MENU)	<u>16</u> : 31		
DTL CORING	0 : <u>2</u> : 15	USER ENG	For setting detail signal noise removal level.
H. DTL FREQ	0 : <u>22</u> : 31	USER ENG	For selecting H.DTL FREQUENCY.
LEVEL DEPEND.	0 : <u>2</u> : 5	USER ENG	For setting LEVEL DEPEND. The detail of only the dark areas is removed when the Y detail is boosted. The higher the figure set for this item, the broader the range of the detail which is removed.
MASTER GAMMA	0.35 : <u>0.45</u> : 0.75	USER ENG	Master gamma setting. (0.01 step)
BLACK STRETCH	+3, +2, +1, <u>OFF</u> , -1, -2, -3	USER ENG	For correcting the black level gradation.
MATRIX TABLE	A B <u>OFF</u>	USER ENG	For selecting the colour correction matrix table.
COLOR CORRECT	ON <u>OFF</u>	USER ENG	For setting the 12-axis independent colour correction to ON or OFF.

MID SETTING screen

The middle level gain is set on this screen.

Item	Variable range	VF display	Remarks
MASTER GAIN (FILM MENU)	-3dB : <u>3dB</u> : 30dB	USER ENG	-3 dB, 0 dB, 3 dB, 6 dB, 9 dB, 12 dB, 18 dB, 24 dB or 30 dB can be set.
(CAM MENU)	-6dB : <u>6dB</u> : 30dB		-6dB, -3 dB, 0 dB, 3 dB, 6 dB, 9 dB, 12 dB, 18 dB, 24 dB or 30 dB can be set.
H. DTL LEVEL (FILM MENU)	0 : <u>8</u> : 12	USER ENG	For setting H.DTL (detail) level.
(CAM MENU)	<u>12</u> : 63		
V. DTL LEVEL (FILM MENU)	0 : <u>12</u> : 16	USER ENG	For setting V.DTL (detail) level.
(CAM MENU)	<u>16</u> : 31		
DTL CORING	0 : <u>2</u> : 15	USER ENG	For setting detail signal noise removal level.
H. DTL FREQ	0 : <u>22</u> : 31	USER ENG	For selecting H.DTL FREQUENCY.
LEVEL DEPEND.	0 : <u>2</u> : 5	USER ENG	For setting LEVEL DEPEND. The detail of only the dark areas is removed when the Y detail is boosted. The higher the figure set for this item, the broader the range of the detail which is removed.
MASTER GAMMA	0.35 : <u>0.45</u> : 0.75	USER ENG	Master gamma setting. (0.01 step)
BLACK STRETCH	+3, +2, +1, <u>OFF</u> , -1, -2, -3	USER ENG	For correcting the black level gradation.
MATRIX TABLE	A B <u>OFF</u>	USER ENG	For selecting the colour correction matrix table.
COLOR CORRECT	ON <u>OFF</u>	USER ENG	For setting the 12-axis independent colour correction to ON or OFF.

The underlining in the variable range column indicates the setting in the preset mode.

Setting menu screens FILM (CAM) MAIN MENU 1

HIGH SETTING screen

The high level gain is set on this screen.

Item	Variable range	VF display	Remarks
MASTER GAIN (FILM MENU)	-3dB : <u>6dB</u> : 30dB	USER ENG	-3 dB, 0 dB, 3 dB, 6 dB, 9 dB, 12 dB, 18 dB, 24 dB or 30 dB can be set.
(CAM MENU)	-6dB : <u>12dB</u> : 30dB		-6dB, -3 dB, 0 dB, 3 dB, 6 dB, 9 dB, 12 dB, 18 dB, 24 dB or 30 dB can be set.
H. DTL LEVEL (FILM MENU)	0 : <u>8</u> : 12 : 63	USER ENG	For setting H.DTL (detail) level.
(CAM MENU)	12 : 16 : 31		
V. DTL LEVEL (FILM MENU)	0 : <u>12</u> : 16 : 31	USER ENG	For setting V.DTL (detail) level.
(CAM MENU)	12 : 16 : 31		
DTL CORING	0 : <u>5</u> : 15	USER ENG	For setting detail signal noise removal level.
H. DTL FREQ	0 : <u>22</u> : 31	USER ENG	For selecting H.DTL FREQUENCY.
LEVEL DEPEND.	0 : <u>5</u>	USER ENG	For setting LEVEL DEPEND. The detail of only the dark areas is removed when the Y detail is boosted. The higher the figure set for this item, the broader the range of the detail which is removed.
MASTER GAMMA	0.35 : <u>0.45</u> : 0.75	USER ENG	Master gamma setting. (0.01 step)
BLACK STRETCH	+3, +2, +1, <u>OFF</u> , -1, -2, -3	USER ENG	For correcting the black level gradation.
MATRIX TABLE	A B <u>OFF</u>	USER ENG	For selecting the colour correction matrix table.
COLOR CORRECT	ON <u>OFF</u>	USER ENG	For setting the 12-axis independent colour correction to ON or OFF.

ADDITIONAL DTL 1 screen

The special detail features of the camera are set on this screen.

Item	Variable range	VF display	Remarks
KNEE APERTURE	<u>ON</u> OFF	USER ENG	For setting the knee aperture to ON or OFF. At the "ON" setting, the detail above the knee point is boosted.
SLIM DTL	ON <u>OFF</u>	USER ENG	For setting the mode to make the detail finer to ON or OFF.

ADDITIONAL DTL2 screen

The special detail features of the camera are set on this screen.

Item	Variable range	VF display	Remarks
KNEE APE LVL	0 : <u>5</u>	USER ENG	For changing the detail level in the high-brightness areas.
DTL GAIN (+)	-31 : <u>+00</u> : +31	USER ENG	For changing the H detail level in the "+" direction.
DTL GAIN (-)	-31 : <u>+00</u> : +31	USER ENG	For changing the H detail level in the "-" (bottom) direction.
DTL CLIP	0 : <u>47</u> : 63	USER ENG	For changing the clipping level of the detail signal.
DTL SOURCE	(G+B)/2 (R+G)/2 (2G+R+B)/4 (3G+R)/4 R G	USER ENG	For setting the ratio between the RGB signal components which generate the detail signal.
V DTL FREQ.	360TV 450TV 540TV <u>630TV</u> 720TV	USER ENG	For setting the V. DTL FREQUENCY.

The underlining in the variable range column indicates the setting in the preset mode.

Setting menu screens FILM (CAM) MAIN MENU 1

SKIN TONE DTL screen

The skin tone detail of the camera is set on this screen.

Item	Variable range	VF display	Remarks
SKIN TONE DTL	ON <u>OFF</u>	USER ENG	For setting the skin tone detail to ON or OFF.
SKIN TONE ZEBRA	ON <u>OFF</u>	USER ENG	For setting zebra in the skin tone range to ON or OFF. At the "ON" setting, the amount of detail in the zebra viewing range is varied.
SKIN DTL CORING	0 : <u>5</u> : 7	USER ENG	For setting detail signal noise removal level.
Y MAX	0 : <u>190</u> : 255	ENG	For setting the maximum luminance level at which the detail is boosted.
Y MIN	0 : <u>10</u> : 255	ENG	For setting the minimum luminance level at which the detail is boosted.
I CENTER	0 : <u>55</u> : 255	ENG	For setting the medium I-axis level at which the detail is boosted.
I WIDTH	0 : <u>90</u> : 255	ENG	For setting the minimum I-axis level at which the detail is boosted.
Q WIDTH	0 : <u>10</u> : 255	ENG	For setting the maximum Q-axis level at which the detail is boosted.
Q PHASE	-31 : <u>0</u> : +31	ENG	For setting the minimum Q-axis level at which the detail is boosted.

The underlining in the variable range column indicates the setting in the preset mode.

KNEE/LEVEL screen

The knee settings of the camera are performed on this screen.

Item	Variable range	VF display	Remarks
MASTER PED (FILM MENU)	-200 : <u>0</u> : +200	USER ENG	For setting the master pedestal level (MASTER PED).
(CAM MENU)	<u>+018</u> : +200		
MANUAL KNEE	ON <u>OFF</u>	USER ENG	For setting the mode when the AUTO KNEE switch is at OFF.
KNEE POINT (FILM MENU)	30% : <u>65%</u> : 90%	USER ENG	For setting the manual knee point position. <Note> This setting is cancelled when FILM REC has been selected as the CINE GAMMA SEL item setting on the GAMMA screen.
(CAM MENU)	<u>80%</u> : <u>95%</u> : 107%		
KNEE SLOPE (FILM MENU)	150% : <u>500%</u> : 600%	USER ENG	For setting the manual knee slope. <Note> This setting is cancelled when FILM REC has been selected as the CINE GAMMA SEL item setting on the GAMMA screen.
(CAM MENU)	<u>0</u> : <u>50</u> : 99		
WHITE CLIP	ON <u>OFF</u>	USER ENG	For setting white clipping to ON or OFF.
WHITE CLIP LVL	90% : <u>109%</u>	USER ENG	For setting the white clipping level.
A. KNEE POINT (CAM MENU)	80% : <u>95%</u> : 100%	USER ENG	For setting the auto knee point position.
(FILM MENU)	<u>100%</u> : 107%		
A. KNEE LVL	100 : <u>108</u> <u>109</u>	USER ENG	For setting the maximum auto knee level.
A. KNEE RESPONSE	1 <u>2</u> 3 4	USER ENG	For setting the AUTO KNEE response rate.

<Note>

The gamma characteristics are set using the KNEE POINT and KNEE SLOPE items when VIDEO REC was selected as the CINE GAMMA SEL item setting on the GAMMA screen.

Setting menu screens FILM (CAM) MAIN MENU 1

GAMMA screen

The gamma settings of the camera are performed on this screen.

Item	Variable range	VF display	Remarks
MASTER GAMMA (FILM MENU)	0.35 : <u>0.45</u> : 0.75	USER ENG	For setting the master gamma when the unit is to be operated in the film mode.
R GAMMA	-15 : <u>+0</u> : +15	USER ENG	Amount by which the R channel gamma is corrected in respect of the master gamma level.
B GAMMA	-15 : <u>+0</u> : +15	USER ENG	Amount by which the B channel gamma is corrected in respect of the master gamma level.
CINE GAMMA SEL (FILM MENU)	FILM REC VIDEO REC	USER ENG	For setting the gamma characteristics when the unit is to be operated in the film mode. FILM REC: The cine gamma characteristics for films are used. VIDEO REC: The cine gamma characteristics for video are used.
BLACK STR. LVL (FILM MENU)	0% : 30%	USER ENG	For setting the black stretch level point position. <Notes> ● This setting is valid when FILM REC has been selected as the CINE GAMMA SEL item setting. ● The KNEE POINT and KNEE SLOPE item settings on the KNEE/LEVEL screen are cancelled.
DYNAMIC LVL (FILM MENU)	200% 300% 400% <u>500%</u>	USER ENG	For setting the dynamic range. <Notes> ● This setting is valid when FILM REC has been selected as the CINE GAMMA SEL item setting. ● The KNEE POINT and KNEE SLOPE item settings on the KNEE/LEVEL screen are cancelled.

<Note>

The gamma characteristics are set using the BLACK STR. LVL and DYNAMIC LVL items when FILM REC has been selected as the CINE GAMMA SEL item setting.

CAMERA SETTING screen

The basic settings of the camera are set to ON or OFF on this screen.

Item	Variable range	VF display	Remarks
DETAIL	<u>ON</u> OFF	USER ENG	For setting the detail (H, V) to ON or OFF. (Both the H detail and V detail are simultaneously set to either ON or OFF.)
HIGH COLOR	ON <u>OFF</u>	USER ENG	For setting the mode for expanding the dynamic range of the colours to ON or OFF. At the ON setting, the colours above the knee point are boosted.
GAMMA	ON OFF	USER ENG	For setting the gamma correction to ON or OFF.
TEST SAW	ON <u>OFF</u>	USER ENG	For setting the test signal to ON or OFF.
FLARE	ON OFF	USER ENG	For setting the flare compensation to ON or OFF.
H-F COMPE	ON OFF	USER ENG	For setting the high-range frequency compensation mode to ON or OFF.
LIGHTING (FILM MENU)	<u>TUNGSTEN</u> DAY LIGHT	USER ENG	For switching the white balance preset value to the tungsten lighting type or daylight type.
D5600 K (CAM MENU)	ON <u>OFF</u>	USER ENG	For setting the 5600 K presetting for the white balance to ON or OFF. <Note> The black balance must always be adjusted (see page 57) when this item's setting has been changed.

The underlining in the variable range column indicates the setting in the preset mode.

Setting menu screens FILM (CAM) MAIN MENU 2

VF DISPLAY screen

The information to be displayed inside the viewfinder is set on this screen.

Item	Variable range	VF display	Remarks																																			
DISP CONDITION	<u>NORMAL</u> HOLD	USER ENG	NORMAL: The statuses are displayed at all times. HOLD: The statuses are displayed when MODE CHECK SW is ON.																																			
DISP MODE	1 2 3	USER ENG	<table border="1"> <thead> <tr> <th rowspan="2">Change</th> <th colspan="3">Display</th> </tr> <tr> <th>1</th> <th>2</th> <th>3</th> </tr> </thead> <tbody> <tr> <td>FILTER</td> <td>×</td> <td>×</td> <td>○</td> </tr> <tr> <td>GAIN</td> <td>×</td> <td>×</td> <td>○</td> </tr> <tr> <td>AWB</td> <td>×</td> <td>×</td> <td>○</td> </tr> <tr> <td>AUTO KNEE SW</td> <td>×</td> <td>○</td> <td>○</td> </tr> <tr> <td>SHUTTER</td> <td>×</td> <td>○</td> <td>○</td> </tr> <tr> <td>ABB STATUS</td> <td>×</td> <td>○</td> <td>○</td> </tr> <tr> <td>AWB STATUS</td> <td>×</td> <td>○</td> <td>○</td> </tr> </tbody> </table>	Change	Display			1	2	3	FILTER	×	×	○	GAIN	×	×	○	AWB	×	×	○	AUTO KNEE SW	×	○	○	SHUTTER	×	○	○	ABB STATUS	×	○	○	AWB STATUS	×	○	○
Change	Display																																					
	1	2	3																																			
FILTER	×	×	○																																			
GAIN	×	×	○																																			
AWB	×	×	○																																			
AUTO KNEE SW	×	○	○																																			
SHUTTER	×	○	○																																			
ABB STATUS	×	○	○																																			
AWB STATUS	×	○	○																																			
VF OUT	<u>Y</u> NAM R G B	USER ENG	For selecting VF OUT. NAM (N Additive Mix): The signal with the highest level among the R, G and B signals is output.																																			
VF DTL	0 : 4 5	USER ENG	For selecting VF DTL. The detail of the signals for VF is further boosted. At the "0" setting, the detail is the same as the unit's.																																			
ZEBRA1 DETECT (CAM MENU) (FILM MENU)	0% : <u>70%</u> : 80% : 109%	USER ENG	For setting the ZEBRA1 detection level (IRE level).																																			
ZEBRA2 DETECT	0% : <u>85%</u> : 109%	USER ENG	For setting the ZEBRA2 detection level (IRE level).																																			
ZEBRA2	ON OFF <u>SPOT</u>	USER ENG	For setting ZEBRA2 to ON or OFF and selecting SPOT. See "Zebra pattern display." <Note> When used at the "SPOT" setting, ensure that the ZEBRA2 DETECT value is set higher than the ZEBRA1 DETECT value. If the ZEBRA2 DETECT value is lower than the ZEBRA1 DETECT value, the ZEBRA display will not appear.																																			

Item	Variable range	VF display	Remarks
LOW LIGHT LVL (FILM MENU) (CAM MENU)	OFF 20% 25% : 40% 45%	USER ENG	For selecting the light level for the LOW LIGHT display when the amount of light entering the camera is too low.
SYNCHRO SCAN DISP. (CAM MENU) (FILM MENU)	sec % deg	USER ENG	For setting the unit in which the synchro scan mode is to be displayed.
ECU MENU DISP.	ON OFF	USER ENG	For setting whether the menu screen is to be displayed when menu operations are performed using the AJ-EC3 Extension Control Unit.

Zebra pattern display

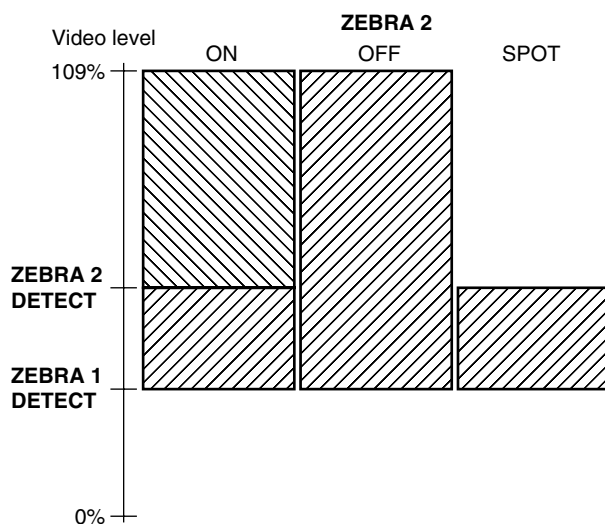

The underlining in the variable range column indicates the setting in the preset mode.

Setting menu screens FILM (CAM) MAIN MENU 2

VF MARKER screen

The information to be displayed inside the viewfinder is set on this screen.

Item	Variable range	VF display	Remarks
SAFETY ZONE	OFF <u>1</u> : <u>3</u> : 12	USER ENG	For selecting the safety zone display. 1 : 80% and 90% corner display 2 : 80% corner display 3 : 90% corner display 4 : 80% and 90% box display 5 : 80% box display 6 : 90% box display 7 : 80% and 90% corner display in 4:3 mode 8 : 80% corner display in 4:3 mode 9 : 90% corner display in 4:3 mode 10 : 80% and 90% box display in 4:3 mode 11 : 80% box display in 4:3 mode 12 : 90% box display in 4:3 mode
CENTER MARK	ON <u>OFF</u>	USER ENG	For setting the centre marker display to ON or OFF.
FRAME SIG	<u>4:3</u> 13:9 14:9 VISTA	USER ENG	For selecting the frame marker display. (VISTA = 1 : 1.85)
MARK	ON <u>OFF</u>	USER ENG	For setting the frame marker display to ON or OFF.
LVL	0 : <u>15</u>	USER ENG	For setting the picture levels on the outside of the frame marker.

VF INDICATOR screen

The information to be displayed inside the viewfinder is set on this screen.

Item	Variable range	VF display	Remarks
EXTENDER	ON <u>OFF</u>	USER ENG	For setting the extender display to ON or OFF.
SHUTTER	ON <u>OFF</u>	USER ENG	For setting the shutter speed display to ON or OFF.
FILTER	ON <u>OFF</u>	USER ENG	For setting the filter No. display to ON or OFF.
WHITE	ON <u>OFF</u>	USER ENG	For setting the AWB PRE/A/B display to ON or OFF.
GAIN	ON <u>OFF</u>	USER ENG	For setting the currently selected gain display to ON or OFF.
IRIS	S IRIS <u>S+IRIS</u> OFF	USER ENG	S : Only the super iris ON status is displayed. IRIS : Only the aperture value is displayed. S+IRIS : Both the super iris ON status and the aperture value are displayed. OFF : Neither the super iris ON status nor the aperture value is displayed.
CAMERA ID	ON <u>OFF</u>	USER ENG	For setting the ID display during colour bar displaying.
ZOOM LVL	ON <u>OFF</u>	USER ENG	For setting the zoom position value display to ON or OFF.
COLOR TEMP	ON <u>OFF</u>	USER ENG	For setting the colour temperature display to ON or OFF.
FRAME RATE	ON <u>OFF</u>	USER ENG	For setting the frame rate display to ON or OFF.
VERSION ID (FILM MENU)	ON <u>OFF</u>	USER ENG	For displaying the gamma curve used when the internal colour bar signal recording mode is established.

The underlining in the variable range column indicates the setting in the preset mode.

Setting menu screens *FILM (CAM) MAIN MENU 2*

CAMERA ID screen

The camera ID is set on this screen.

Item	Variable range	VF display	Remarks
ID 1: *****	—	ENG	For inputting the camera ID (max. 10 characters). <Note> Select whether this setting is to be mixed by selecting ON or OFF for CAMERA ID on the VF DISPLAY screen.
ID 2: *****			
ID 3: *****			

- Turn the JOG dial button to move the arrow (cursor) to the ID 1, ID 2, or ID 3: item.
- When the JOG dial button is pressed, the arrow (cursor) moves to the ID input area, and the input mode is established.
- Press the JOG dial button again and turn it until the character to be set is displayed.
When the button is turned, the character displayed is switched in the following sequence:
Space:
↓
letters: A—Z
↓
numbers: 0—9
↓
symbols: ', >, <, /, —
- Press the JOG dial button to enter the character.
- Turn the JOG dial button to move the arrow (cursor) to the next position (right), and repeat steps 3 and 4 to input the characters (maximum of 10).
- When the characters have been input, turn the JOG dial button to move the arrow (cursor) to the “.” position.



- When the JOG dial button is pressed, the arrow (cursor) returns to the ID 1, ID 2, or ID 3: item.

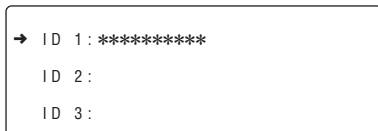

SHUTTER SPEED screen

On this screen, the shutter speed to be used is selected from among the POSITION items each of which contains a shutter speed which was set on the SHUTTER SELECT screen.

Item	Variable range	VF display	Remarks
SYNCHRO SCAN 1	ON OFF	ENG	For selecting SYNCHRO SCAN 1.
SYNCHRO SCAN 2	ON OFF	ENG	For selecting SYNCHRO SCAN 2.
POSITION 1	ON OFF	ENG	For selecting POSITION 1.
POSITION 2	ON OFF	ENG	For selecting POSITION 2.
POSITION 3	ON OFF	ENG	For selecting POSITION 3.
POSITION 4	ON OFF	ENG	For selecting POSITION 4.
POSITION 5	ON OFF	ENG	For selecting POSITION 5.
POSITION 6	ON OFF	ENG	For selecting POSITION 6.

The underlining in the variable range column indicates the setting in the preset mode.

Setting menu screens *FILM (CAM) MAIN MENU 2*

SHUTTER SELECT screen

A shutter speed is set in each POSITION item on this screen.

Item	Variable range	VF display	Remarks
SYNCHRO SCAN 2	90.0 deg : <u>180.0 deg</u> : 225.0 deg	ENG	For selecting the shutter speed which is to be set in SYNCHRO SCAN 2.
POSITION 1 SEL (FILM MENU) (CAM MENU)	180.0 deg 172.8 deg 144.0 deg 120.0 deg 90.0 deg 45.0 deg <u>1/100</u> 1/120 1/250 1/500 1/1000 1/2000	ENG	For selecting the shutter speed which is to be set in POSITION 1.
POSITION 2 SEL (FILM MENU) (CAM MENU)	180.0 deg <u>172.8 deg</u> 144.0 deg 120.0 deg 90.0 deg 45.0 deg <u>1/100</u> <u>1/120</u> 1/250 1/500 1/1000 1/2000	ENG	For selecting the shutter speed which is to be set in POSITION 2.
POSITION 3 SEL (FILM MENU) (CAM MENU)	180.0 deg 172.8 deg <u>144.0 deg</u> 120.0 deg 90.0 deg 45.0 deg 1/100 1/120 <u>1/250</u> 1/500 1/1000 1/2000	ENG	For selecting the shutter speed which is to be set in POSITION 3.













Item	Variable range	VF display	Remarks
POSITION 4 SEL (FILM MENU) (CAM MENU)	180.0 deg 172.8 deg 144.0 deg <u>120.0 deg</u> 90.0 deg 45.0 deg 1/100 1/120 1/250 <u>1/500</u> 1/1000 1/2000	ENG	For selecting the shutter speed which is to be set in POSITION 4.
POSITION 5 SEL (FILM MENU) (CAM MENU)	180.0 deg 172.8 deg 144.0 deg 120.0 deg <u>90.0 deg</u> 45.0 deg 1/100 1/120 1/250 1/500 <u>1/1000</u> 1/2000	ENG	For selecting the shutter speed which is to be set in POSITION 5.
POSITION 6 SEL (FILM MENU) (CAM MENU)	180.0 deg 172.8 deg 144.0 deg 120.0 deg 90.0 deg <u>45.0 deg</u> 1/100 1/120 1/250 1/500 1/1000 <u>1/2000</u>	ENG	For selecting the shutter speed which is to be set in POSITION 6.

The underlining in the variable range column indicates the setting in the preset mode.

Setting menu screens *FILM (CAM) MAIN MENU 2*

! LED screen

The display of the  lamp which appears inside the viewfinder is set to ON or OFF on this screen.

Item	Variable range	VF display	Remarks
GAIN (0 dB)	ON OFF	USER ENG	For setting whether the  lamp is to be turned on when the gain level is other than 0 dB.
GAIN (-3 dB)	ON OFF	USER ENG	For setting whether the  lamp is to be turned on when the gain level is other than -3 dB.
SHUTTER	ON OFF	USER ENG	For setting whether the  lamp is to be turned on when the shutter is ON.
WHITE PRESET	ON OFF	USER ENG	For setting whether the  lamp is to be turned on when PRESET is selected as the AWB channel setting.
EXTENDER	ON OFF	USER ENG	For setting whether the  lamp is to be turned on when the lens has been set to the EXTENDER mode.
FILTER	ON OFF	USER ENG	For setting whether the  lamp is to be turned on when a filter other than 3200 K is used.
BLACK STR	ON OFF	USER ENG	For setting whether the  lamp is to be turned on when black stretch has been set to ON.
DAY LIGHT (FILM MENU)	ON OFF	USER ENG	For setting whether the  lamp is to be turned on when the white balance preset value is the daylight type.
D5600 K (CAM MENU)	ON OFF	USER ENG	For setting whether the  lamp is to be turned on when the preset white balance level is 5600 K.
MATRIX	ON OFF	USER ENG	For setting whether the  lamp is to be turned on when matrix has been set to ON.
COLOR CORRECTION	ON OFF	USER ENG	For setting whether the  lamp is to be turned on when colour correction has been set to ON.
FRAME RATE	ON OFF	USER ENG	For setting whether the  lamp is to be turned on when the frame rate less than 11 fps is used.

<Note>

When ON has been selected for both GAIN (0 dB) and GAIN (-3 dB), the  lamp will light at all gain levels except for -3 dB and 0 dB.

CAMERA SW MODE screen

The modes of the camera switches are set on this screen.

Item	Variable range	VF display	Remarks
FILTER INH	ON OFF	USER ENG	For selecting whether or not the data in the AWB memories (channel A, channel B) is to be held for each filter. ON: Only the channel A and channel B memories (2 memories) regardless of the filter. OFF: The data is held for each of the filters (4×2 = 8 memories).
SHOCKLESS AWB	OFF NORMAL SLOW FAST	USER ENG	For selecting the SHOCKLESS AWB setting. “SHOCKLESS AWB” means that the switching of the WHITE BAL switch to A, B or PRST is not accompanied by a shock. FAST (high-speed: approx. 0.5 sec.), NORMAL (normal speed: approx. 1 sec.) or SLOW (slow: approx. 3 sec.) can be set for this effect.
COLOR BARS	SMPTE FULL BARS	USER ENG	For selecting the colour bar signals. SMPTE: SMPTE colour bars FULL BARS: Full colour bars
S. GAIN OFF	S.GAIN L/M/H	USER ENG	For selecting the method for releasing the super gain mode. S.GAIN: The mode is released by the super gain switch only. L/M/H: The mode is released by changing the L/M/H switch setting.

The underlining in the variable range column indicates the setting in the preset mode.

Setting menu screens *FILM (CAM) MAIN MENU 2*

SUPER GAIN screen

The gain allocated to the SUPER GAIN switch is set on this screen.

Item	Variable range	VF display	Remarks
S. GAIN VALUE	<u>18dB</u> 24dB 30dB 36dB	USER ENG	For selecting the gain when the SUPER GAIN switch is pressed.

FRAME MODE screen

The frame rate is set on this screen.

Item	Variable range	VF display	Remarks
FRAME RATE RANGE	<u>60-12</u> 60-4	USER ENG	For selecting the variable range of the frame rate. 60-12: 60 fps to 12 fps 60-4: 60 fps to 4 fps
FRAME RATE (CAM MENU) (FILM MENU)	<u>60</u> : <u>24</u> : 4	USER ENG	For setting the frame rate. <Note> When "60-12" has been selected as the FRAME RATE RANGE setting, the frame rate cannot be set to 11 fps or below.
SCAN REVERSE	ON <u>OFF</u>	USER ENG	This function is for correcting the images when the prime lens is used. ON : The images are corrected (by reversing their top and bottom and their left and right). OFF : The images are not corrected.

The underlining in the variable range column indicates the setting in the preset mode.

Setting menu screens FILM (CAM) MAIN MENU 3

CAM CARD READ/WRITE screen

The settings for saving (writing) the menu data on the setup card, loading (reading) the data from the card, and configuring the card are performed on this screen.

Item	Variable range	VF display	Remarks
SELECT	<u>1</u> : 8	USER ENG	For selecting the number of the file to be loaded.
READ	—	USER ENG	For loading the data from the setup card.
SELECT	<u>1</u> : 8	USER ENG	For selecting the number of the file to be saved.
WRITE	—	USER ENG	For saving the camera's data on the setup card.
CARD CONFIG	—	USER ENG	For formatting the setup card.
TITLE READ	—	USER ENG	For reading the titles given to the data saved on the setup card.
READ USER DATA	—	USER ENG	For loading the user area data of the camera's memory.
TITLE 1: to TITLE 8:	—	USER ENG	A title consisting of up to 8 characters can be given to each file.

CAM CARD R/W SELECT screen

The settings for saving (recording) specific menu data on the setup card and loading (reading) the data from the card are performed on this screen.

Item	Variable range	VF display	Remarks
ID READ/WRITE	<u>ON</u> <u>OFF</u>	USER ENG	For setting camera ID saving/loading when writing data onto the setup card or loading data from it to ON or OFF. ON : The camera ID is recorded/loaded. OFF : The camera ID is not recorded/loaded. Example: If the CAMERA ID contents are not to be changed when setup card data is saved/loaded, select OFF as the ID READ/WRITE setting.

CAM CARD R/W SELECT screen

Item	Variable range	VF display	Remarks
CAM MAIN MENU1 LEVEL R/W	<u>ON</u> <u>OFF</u>	USER ENG	For setting FILM (CAM) MAIN MENU 1 (items other than those marked with ■) data saving/loading when writing data onto the setup card or loading data from it to ON or OFF. ON : The data is recorded/loaded. OFF : The data is not recorded/loaded. <Note> See page 89 for information on the items marked with ■.
CAM MAIN MENU1 SW (■) R/W	<u>ON</u> <u>OFF</u>	USER ENG	For setting FILM (CAM) MAIN MENU 1 (items marked with ■) data saving/loading when writing data onto the setup card or loading data from it to ON or OFF. ON : The data is recorded/loaded. OFF : The data is not recorded/loaded.
CAM MAIN MENU2 R/W	<u>ON</u> <u>OFF</u>	USER ENG	For setting FILM (CAM) MAIN MENU 2 data saving/loading when writing data onto the setup card or loading data from it to ON or OFF. ON : The data is recorded/loaded. OFF : The data is not recorded/loaded.
CAM MAIN MENU3 R/W	<u>ON</u> <u>OFF</u>	USER ENG	For setting FILM (CAM) MAIN MENU 3 data saving/loading when writing data onto the setup card or loading data from it to ON or OFF. ON : The data is recorded/loaded. OFF : The data is not recorded/loaded.
CAM MAIN MENU4 R/W	<u>ON</u> <u>OFF</u>	USER ENG	For setting FILM (CAM) MAIN MENU 4 data saving/loading when writing data onto the setup card or loading data from it to ON or OFF. ON : The data is recorded/loaded. OFF : The data is not recorded/loaded.

<Note>

When the frame frequency setting has been changed, it is necessary to restart the unit by turning the POWER switch to OFF and then to ON again for the setting to be switched.

The underlining in the variable range column indicates the setting in the preset mode.

Setting menu screens *FILM (CAM) MAIN MENU 3*

GENLOCK/IRIS screen

The genlock and iris control settings are performed on this screen.

Item	Variable range	VF display	Remarks
H PHASE COARSE	0 : <u>7</u> : 15	USER ENG	For coarsely adjusting the H phase during genlock.
H PHASE FINE	0 : <u>32</u> : 64	USER ENG	For finely adjusting the H phase during genlock.
A. IRIS LEVEL	0 : <u>50</u> : 100	USER ENG	For setting the auto iris target level. The brightness (iris) is controlled using this value. The higher the value selected, the higher the brightness.
A. IRIS PEAK/AVE	0 : <u>50</u> : 100	USER ENG	For setting the ratio between the auto iris peak and average value. The closer the setting is to 0, the greater the tendency toward average control; conversely, the closer the setting is to 100, the greater the tendency toward peak control.
A. IRIS MODE	<u>NORM1</u> NORM2 CENTR	USER ENG	For selecting the auto iris mode. NORM1: The light is measured for the entire screen (except for the edges). NORM2: The light is measured for the entire screen (except for the top part). CENTR: The light is measured in the centre area of the screen only.
S. IRIS LEVEL	0 : <u>80</u> : 100	USER ENG	For setting the super iris target level. (Backlight compensation mode)
IRIS GAIN	CAM <u>LENS</u>	USER ENG	For setting whether the iris gain is to be adjusted by the camera or lens.
IRIS GAIN VALUE	1 : <u>6</u> : 10	USER ENG	For setting the iris gain adjustment value.

The underlining in the variable range column indicates the setting in the preset mode.

LENS ADJ screen

The lens adjustments are performed on this screen.

Item	Variable range	VF display	Remarks
F2.8 ADJ	ON <u>OFF</u>	ENG	For outputting the voltage output only when ON is selected as this item's setting.
F16 ADJ	ON <u>OFF</u>	ENG	For outputting the voltage output only when ON is selected as this item's setting.

<Note>

When using a lens which enables the open limit and close limit of the lens aperture to be adjusted, set "F2.8ADJ" or "F16ADJ" to ON, and repeatedly adjust so that the lens aperture will be set to "F2.8" or "F16."

(This adjustment need not be performed if the lens does not have this adjustment function.)

Setting menu screens *FILM (CAM) MAIN MENU 4*

FILM (CAM) USER MENU SELECT 1, 2 and 3 screens

The settings for registering the items (the same as the ones on the FILM or CAM MAIN MENU 1, 2 and 3 screens) allocated to the SUB menus to the SUB MENU screen are performed on this screen.

Registration ON (✱) or OFF (●) is set at the head of each item.

Up to 42 camera unit items can be registered.

FILM (CAM) USER MENU SELECT 1 screen

SUB menu	VF display	Remarks
ROP	ENG	Index for opening the ROP screen.
LOW SETTING	ENG	Index for opening the LOW SETTING screen.
MID SETTING	ENG	Index for opening the MID SETTING screen.
HIGH SETTING	ENG	Index for opening the HIGH SETTING screen.
ADDITIONAL DTL1	ENG	Index for opening the ADDITIONAL DTL1 screen.
ADDITIONAL DTL2	ENG	Index for opening the ADDITIONAL DTL2 screen.
SKIN TONE DTL	ENG	Index for opening the SKIN TONE DTL screen.
KNEE/LEVEL	ENG	Index for opening the KNEE/LEVEL screen.
GAMMA	ENG	Index for opening the GAMMA screen.
CAMERA SETTING	ENG	Index for opening the CAMERA SETTING screen.

FILM (CAM) USER MENU SELECT 2 screen

SUB menu	VF display	Remarks
VF DISPLAY	ENG	Index for opening the VF DISPLAY screen.
VF MARKER	ENG	Index for opening the VF MARKER screen.
VF INDICATOR	ENG	Index for opening the VF INDICATOR screen.
!LED	ENG	Index for opening the !LED screen.
CAMERA SW MODE	ENG	Index for opening the CAMERA SW MODE screen.
SUPER GAIN	ENG	Index for opening the SUPER GAIN screen.
FRAME MODE	ENG	Index for opening the FRAME MODE screen.

FILM (CAM) USER MENU SELECT 3 screen

SUB menu	VF display	Remarks
CAM CARD READ/WRITE	ENG	Index for opening the CAM CARD READ/WRITE screen.
CAM CARD R/W SELECT	ENG	Index for opening the CAM CARD R/W SELECT screen.
GENLOCK/IRIS	ENG	Index for opening the GENLOCK/IRIS screen.

Setting menu screens FILM (CAM) MAIN MENU 4

BLACK SHADING screen

The black shading adjustments are performed on this screen.

Item	Variable range	VF display	Remarks
DETECTION	—	ENG	For execution of the digital shading compensation.
CORRECT (DIG)	<u>ON</u> OFF	ENG	For setting the digital shading compensation to ON or OFF.

WHITE SHADING screen

The white shading adjustments are performed on this screen.

Item	Variable range	VF display	Remarks
SELECT	<u>1</u> : 8	ENG	For designating the white shading file number.
READ	—	ENG	For reading the white shading file designated by the SELECT item.
DETECTION (V SAW)	—	ENG	For executing vertical white shading compensation and recording the data in the white shading file designated by the SELECT item.
CORRECT	<u>ON</u> OFF	ENG	For setting the shading compensation to ON or OFF.
TITLE	—	ENG	A title consisting of up to 12 characters can be given to each file.

FLARE screen

The camera's flare settings are performed on this screen.

Item	Variable range	VF display	Remarks
R FLARE	0 : <u>100</u>	ENG	For setting the R channel flare; the preset value differs from one camera to another.
G FLARE	0 : <u>100</u>	ENG	For setting the G channel flare; the preset value differs from one camera to another.
B FLARE	0 : <u>100</u>	ENG	For setting the B channel flare; the preset value differs from one camera to another.

The underlining in the variable range column indicates the setting in the preset mode.

COLORIMETRY screen

The luminance signal standard is selected on this screen.

Item	Variable range	VF display	Remarks
MATRIX	<u>SMPTE-274</u> SMPTE-240 NTSC	ENG	For selecting the luminance signal standard.

INITIALIZE screen

The film or camera menu settings are initialized and scene files are saved on this screen.

Item	Variable range	VF display	Remarks
READ FACTORY DATA	—	ENG	For restoring the film or camera menu data settings to the factory settings.
WRITE USER DATA	—	ENG	For saving the user's own film or camera menu data in the unit's memory.
SCENE SEL	<u>1</u> : 4	ENG	For designating the number of the scene file.
READ	—	ENG	For loading the scene file whose SCENE SEL was designated.
WRITE	—	ENG	For saving data in the scene file whose SCENE SEL was designated.
RESET	—	ENG	For restoring the scene file data settings to the factory settings.
TITLE 1	—	ENG	For setting the title in scene file No.1.
TITLE 2	—	ENG	For setting the title in scene file No.2.
TITLE 3	—	ENG	For setting the title in scene file No.3.
TITLE 4	—	ENG	For setting the title in scene file No.4.

<Note>

When the frame frequency setting has been changed, it is necessary to restart the unit by turning the POWER switch to OFF and then to ON again for the setting to be switched.

Setting menu screens *FILM (CAM) MAIN MENU 4*

DIAGNOSTIC screen

The usage statuses and software versions are displayed on this screen.

Item	Variable range	VF display	Remarks
CAMSOFT (IN)	—	ENG	For displaying the version of the software for the built-in flash memory.
CAMSOFT (OUT)	—	ENG	For displaying the version of the software for the external flash memory.
CAM TABLE	—	ENG	For displaying the version of the gamma table.
PLD (CAM)	—	ENG	For displaying the version of the software for the camera system computer.
PLD (SHD)	—	ENG	For displaying the version of the software for the shading.

EVALUATION screen

The items which are measured for evaluation purposes are set on this screen.
(S/N, MODULATION, RESOLUTION, SENSITIVITY)

SUB menu	VF display	Remarks
S/N	ENG	Index for opening the S/N measurement screen.
MODULATION	ENG	Index for opening the modulation measurement screen.
RESOLUTION	ENG	Index for opening the resolution measurement screen.
SENSITIVITY	ENG	Index for opening the sensitivity measurement screen.

OPTION screen

The engineer menu display is selected on this screen.

Item	Variable range	VF display	Remarks
ENG SECURITY	<u>ON</u> <u>OFF</u>	ENG	For selecting whether to display the engineer menu. ON : The engineer menu is not displayed. OFF : The engineer menu is displayed.
SHD, ABB SW CTRL	<u>ON</u> <u>OFF</u>	ENG	For selecting whether to automatically correct black shading when the AUTO W/B BAL switch is pressed continuously for 8 seconds or more on the ABB side. ON : Black shading is corrected automatically. OFF : Black shading is not corrected automatically.
AWB AREA	<u>25%</u> <u>50%</u> <u>90%</u>	ENG	For selecting the white balance search area.
AWB & ABB OFFSET	<u>ON</u> <u>OFF</u>	ENG	For setting how gain and pedestal values, which are set on the ROP screen of FILM (CAM) MAIN MENU 1, are to be processed after auto white balance and auto black balance are performed. ON : Settings are added. OFF : The values are reset to zero.
CAM MENU SEL	<u>VIDEO MENU</u> <u>FILM MENU</u>	ENG	For setting the unit's operation mode. VIDEO MENU: The unit is set to the video mode. FILM MENU: The unit is set to the film mode.
SYSTEM FREQ.	<u>59.94Hz</u> <u>60.00Hz</u>	ENG	For setting the unit's frame frequency.

<Note>

For details on how to release ENG SECURITY, consult your nearest service centre.

The underlining in the variable range column indicates the setting in the preset mode.

Setting menu screens *FILM (CAM) MAIN MENU 4*

EVALUATION screen

● S/N measurement screen

The S/N measurements are performed on this screen.

Item	Variable range	VF display	Remarks
S/N		ENG	For setting the S/N measurement.
DETAIL	ON <u>OFF</u>	ENG	For setting the DETAIL to ON or OFF.
H-F COMPE.	ON <u>OFF</u>	ENG	For setting the high-frequency compensation to ON or OFF.
GAMMA	ON <u>OFF</u>	ENG	For setting the GAMMA to ON or OFF.
MATRIX	ON <u>OFF</u>	ENG	For setting the MATRIX to ON or OFF.
FLARE	ON <u>OFF</u>	ENG	For setting the FLARE to ON or OFF.
M. PED	-200 : <u>0</u> : +200	ENG	For adjusting the master pedestal level.

● Modulation measurement screen

The modulation measurements are performed on this screen.

Item	Variable range	VF display	Remarks
MODULATION		ENG	For setting the modulation measurement.
DETAIL	ON <u>OFF</u>	ENG	For setting the DETAIL to ON or OFF.
H-F COMPE.	ON <u>OFF</u>	ENG	For setting the high-frequency compensation to ON or OFF.
GAMMA	ON <u>OFF</u>	ENG	For setting the GAMMA to ON or OFF.
MATRIX	ON <u>OFF</u>	ENG	For setting the MATRIX to ON or OFF.
FLARE	ON <u>OFF</u>	ENG	For setting the FLARE to ON or OFF.
M. PED (FILM MENU) (CAM MENU)	-200 : <u>0</u> : <u>+18</u> : +200	ENG	For adjusting the master pedestal level.

● Resolution measurement screen

The resolution measurements are performed on this screen.

Item	Variable range	VF display	Remarks
RESOLUTION		ENG	For setting the resolution measurement.
DETAIL	ON <u>OFF</u>	ENG	For setting the DETAIL to ON or OFF.
H-F COMPE.	ON <u>OFF</u>	ENG	For setting the high-frequency compensation to ON or OFF.
GAMMA	ON <u>OFF</u>	ENG	For setting the GAMMA to ON or OFF.
MATRIX	ON <u>OFF</u>	ENG	For setting the MATRIX to ON or OFF.
FLARE	ON <u>OFF</u>	ENG	For setting the FLARE to ON or OFF.
M. PED (FILM MENU) (CAM MENU)	-200 : <u>0</u> : <u>+18</u> : +200	ENG	For adjusting the master pedestal level.

● Sensitivity measurement screen

The sensitivity measurements are performed on this screen.

Item	Variable range	VF display	Remarks
SENSITIVITY		ENG	For setting the sensitivity measurement.
KNEE	ON <u>OFF</u>	ENG	For setting the KNEE to ON or OFF.
W. CLIP	ON <u>OFF</u>	ENG	For setting the white clip to ON or OFF.
M. PED (FILM MENU) (CAM MENU)	-200 : <u>0</u> : <u>+18</u> : +200	ENG	For adjusting the master pedestal level.

The underlining in the variable range column indicates the setting in the preset mode.

Setting menu screens VTR MENUS

VTR MAIN MENU screen

SUB menu	VF display	Remarks
FUNCTION	ENG	Index for opening the FUNCTION screen.
BATTERY/TAPE	ENG	Index for opening the BATTERY/TAPE screen.
BATTERY SETTING	ENG	Index for opening the BATTERY SETTING screen.
VTR VF INDICATOR	ENG	Index for opening the VTR VF INDICATOR screen.
MIC/AUDIO	ENG	Index for opening the MIC/AUDIO screen.
TC/UB	ENG	Index for opening the TC/UB screen.
TIME/DATE	ENG	Index for opening the TIME/DATE screen.
VTR USER MENU SELECT	ENG	Index for opening the VTR USER MENU SELECT screen.
VTR CARD READ/WRITE	ENG	Index for opening the VTR CARD READ/WRITE screen.
VTR INITIALIZE	ENG	Index for opening the VTR INITIALIZE screen.
DIAGNOSTIC	ENG	Index for opening the VTR DIAGNOSTIC screen.

Setting menu screens VTR MAIN MENU

FUNCTION screen

The VTR's functions are set on this screen.

Item	Variable range	VF display	Remarks
NEWS REC MODE	<u>OFF</u> 0.2 : 2.0	USER ENG	For selecting the VTR START button acknowledgment time during recording. OFF: The pressing of the VTR START button is acknowledged immediately, recording is stopped, and the unit is set to the REC PAUSE mode. 0.2—2.0: The pressing of the VTR START button is not acknowledged and recording is continued for the time set (in increments of 0.2 sec.).
HUMID OPE	<u>ON</u> <u>OFF</u>	USER ENG	For selecting the VTR operation when condensation has formed. ON : Operation is continued as usual. OFF : Operation of all controls except the POWER switch and EJECT button is inhibited.
REC START	<u>ALL</u> <u>NORMAL</u>	USER ENG	For selecting acknowledgement of recording started by the VTR START button. ALL: The start of the recording is acknowledged regardless of the VTR mode. NORMAL: The start of the recording is acknowledged only in the STOP (POWER SAVE) mode and REC PAUSE mode.
PAUSE TIMER	10 20 <u>30</u> 60	USER ENG	For selecting the amount of time REC PAUSE is to be held. 10/20/30/60: 10, 20, 30 or 60 minutes.
RETAKE MODE	<u>ON</u> <u>OFF</u>	USER ENG	Functions for rewinding the tape to the position where recording started. ON : The RETAKE function works. OFF : The RETAKE function does not work. <Note> The RETAKE function is set OFF when the unit's power switch has been set to ON.

Item	Variable range	VF display	Remarks
HD SDI OUT	<u>ON</u> SIDE SW <u>AUTO</u> OFF	USER ENG	For controlling the output signals of the HD SDI OUT connector. However, ON or OFF cannot be selected for these signals during recording; the status prior to the start of the recording is maintained. ON: The signals are forcibly output. However, the signals are output in the EE/PB mode when the MONITOR OUT SDI switch on the side panel is set to OFF. SIDE SW: The signals are not output when the MONITOR OUT SDI switch on the side panel is set to OFF. AUTO: The signals are output when the connector has been connected to the output connector. However, the signals are output in the EE/PB mode when the MONITOR OUT SDI switch on the side panel is set to OFF. OFF: The output is stopped.
INTERVAL REC MODE	<u>ON</u> ONE SHOT <u>OFF</u>	USER ENG	For selecting the intermittent recording mode. ON: Intermittent recording is performed. ONE SHOT: Intermittent recording is performed once and then stopped. OFF: Intermittent recording is not performed. <Note> Intermittent recording is set OFF when the unit's power switch has been set to ON.
INTERVAL REC TIME	<u>00s10f</u> : 59s29f	USER ENG	For setting the REC time for intermittent recording. <Note> When REC time is set at less than 1 second, the initial recording time will be 1 second.
INTERVAL PAUSE TIME	<u>00h00m02s</u> : 23h59m59s	USER ENG	For setting the REC PAUSE time for intermittent recording.

The underlining in the variable range column indicates the setting in the preset mode.

Setting menu screens VTR MAIN MENU

FUNCTION screen

Item	Variable range	VF display	Remarks
ECU REC CHK SW	<u>R. REVIEW</u> RETAKE	USER ENG	For selecting the unit operation when the REC CHK button on the AJ-EC3 extension control unit is pressed. R. REVIEW: Rec review is performed. RETAKE: Retake is performed, then playback.
CHARACTER ON SDI	<u>MENU</u> STATUS	USER ENG	For selecting the item to be superimposed on the SDI output signals. MENU: The menu screen is superimposed. STATUS: The menu screen and viewfinder status display are superimposed. <Note> Neither of these items will be superimposed when the CHARACTER switch on the side panel is set to OFF.

BATTERY/TAPE screen

The warning tone which signals the remaining battery charge and remaining tape and which is heard during shooting can be switched off if they prove to be distracting.

Item	Variable range	VF display	Remarks
BATTERY SELECT	<u>AJ-BP490</u> AU-BP402 HP-30A <u>PRO14</u> TRIM14 TRIM13 DIGITAL14 DIGITAL13 BP-H90 BP-H100 NP-L40 NP-L40 D BP-L60/90 NP-1B	USER ENG	For selecting the type of battery used. AJ-BP490 : AJ-BP490 battery AU-BP402 : AU-BP402 battery HP-30A : PACO HP-30A battery PRO14 : Anton/Bauer PRO14 battery TRIM14 : Anton/Bauer TRIM14 battery TRIM13 : Anton/Bauer TRIM13 battery DIGITAL14 : Anton/Bauer DIGITAL battery (14V) DIGITAL13 : Anton/Bauer DIGITAL battery (13V) BP-H90 : IDX BP-H90 battery BP-H100 : IDX BP-H100 battery NP-L40 : IDX NP-L40 battery NP-L40D : IDX NP-L40D battery BP-L60/90 : Sony BP-L60/90 battery NP-1B : Sony NP-1B battery
EXT DC IN SELECT	<u>AC-ADPT</u> AJ-BP490 AU-BP402 HP-30A PRO14 TRIM14 TRIM13 BP-H90 BP-H100 NP-L40 BP-L60/90 NP-1B	USER ENG	For selecting the power source to be connected to the DC IN socket.

The underlining in the variable range column indicates the setting in the preset mode.

BATTERY/TAPE screen

Item	Variable range	VF display	Remarks
BATT NEAR END ALARM	ON <u>OFF</u>	USER ENG	For setting the warning tone heard when the battery is near the end of its charge to ON or OFF.
BATT NEAR END CANCEL	ON <u>OFF</u>	USER ENG	For switching the function which cancels the warning tone heard when the battery is near the end of its charge to ON or OFF using the MODE switch.
BATT END ALARM	ON <u>OFF</u>	USER ENG	For setting the warning tone heard when the battery is at the end of its charge to ON or OFF.
BATT REMAIN FULL	100% <u>70%</u>	USER ENG	For selecting the battery capacity at which "FULL" is to appear on the LCD display window as the remaining battery display (for all 7 segments to be lit).
TAPE NEAR END ALARM	ON <u>OFF</u>	USER ENG	For setting the warning tone heard when the end of the tape is near to ON or OFF.
TAPE NEAR END TIME	3min <u>2min</u>	USER ENG	For setting the remaining tape time for which the warning tone is to be heard when the end of the tape is near.
TAPE END ALARM	ON <u>OFF</u>	USER ENG	For setting the warning tone heard when the tape has reached its end to ON or OFF.
TAPE REMAIN/■	3min/■ <u>5min/■</u>	USER ENG	For setting the time for one segment of the remaining tape display indicated on the LCD display window. 3min/■ : One segment is set to 3 minutes. 5min/■ : One segment is set to 5 minutes.

BATTERY SETTING screen

The type of battery to be used is selected and its settings are performed on this screen.

Item	Variable range	VF display	Remarks
AJ-BP490	MANUAL <u>AUTO</u>	ENG	For setting the AJ-BP490 and the PACO HP-90A battery.
AU-BP402	MANUAL <u>AUTO</u>	ENG	For setting the AU-BP402 battery.
HP-30A	MANUAL <u>AUTO</u>	ENG	For setting the PACO HP-30A battery.
PRO14	MANUAL <u>AUTO</u>	ENG	For setting the Anton/Bauer PRO14 battery.
TRIM14	MANUAL <u>AUTO</u>	ENG	For setting the Anton/Bauer TRIM14 battery.
TRIM13	MANUAL <u>AUTO</u>	ENG	For setting the Anton/Bauer TRIM13 battery.
DIGITAL14	MANUAL <u>AUTO</u>	ENG	For setting the Anton/Bauer digital battery (14V).
DIGITAL13	MANUAL <u>AUTO</u>	ENG	For setting the Anton/Bauer digital battery (13V).
BP-H90	MANUAL <u>AUTO</u>	ENG	For setting the IDX BP-H90 battery.
BP-H100	MANUAL <u>AUTO</u>	ENG	For setting the IDX BP-H100 battery.
NP-L40	MANUAL <u>AUTO</u>	ENG	For setting the IDX NP-L40 battery.
NP-L40 D	MANUAL <u>AUTO</u>	ENG	For setting the IDX NP-L40D battery.
BP-L60/90	MANUAL <u>AUTO</u>	ENG	For setting the Sony BP-L60/90 battery.
NP-1B	MANUAL <u>AUTO</u>	ENG	For setting the Sony NP-1B battery.

1. Either "*" or "●" appears in front of each item to indicate whether the item is set to ON or OFF.

- * : ON
- : OFF

2. Each time the JOG dial button is pressed, the setting moves in the following sequence:

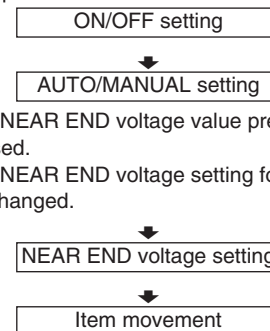

AUTO : The NEAR END voltage value preset in each battery is used.

MANUAL : The NEAR END voltage setting for each battery can be changed.

The underlining in the variable range column indicates the setting in the preset mode.

Setting menu screens VTR MAIN MENU

VTR VF INDICATOR screen

The information to be displayed in the viewfinder is set on this screen.

Item	Variable range	VF display	Remarks
TAPE (IND)	<u>ON</u> OFF	USER ENG	For switching the remaining tape display to ON or OFF.
BATTERY (IND)	<u>ON</u> OFF	USER ENG	For switching the battery voltage display to ON or OFF.
LEVEL METER (IND)	<u>CH1</u> <u>CH1•CH2</u> OFF	USER ENG	For selecting what the audio level meter is to display. CH1: The level of the CH1 signals only is displayed. CH1•CH2: The levels of both the CH1 and CH2 signals are displayed. OFF: No display.
AUDIO IN (IND)	<u>ON</u> OFF	USER ENG	For switching the audio input display to ON or OFF. ON: The audio input is displayed. OFF: The audio input is not displayed.
TC (IND)	<u>TCG</u> <u>TCR</u> <u>TCG/TCR</u> OFF	USER ENG	For selecting what the time code is to display. TCG: The time code generated by the time code generator is displayed in the E-E mode. TCR: The time code reader value is displayed in the V-V mode. TCG/TCR: The time code generated by the time code generator is displayed in the E-E mode; the time code reader value is displayed in the V-V mode. OFF: The time code is not displayed.
VTR WARNING (IND)	<u>ALWAYS</u> <u>NORMAL</u> OFF	USER ENG	For setting when the VTR's warnings are to be displayed. ALWAYS: The warning display always appears when a warning has occurred. NORMAL: The display appears for 3 seconds after the warning occurred and for 3 seconds after recording was started or completed. OFF: The warning displays do not appear.

Item	Variable range	VF display	Remarks
SAVE LED	<u>SAVE&TAPE</u> <u>SAVE</u>	USER ENG	For setting the operation of the SAVE lamp. SAVE: This lights when the VTR SAVE/STBY switch has been set to SAVE. It goes off during recording. SAVE&TAPE: This lights when the VTR SAVE/STBY switch has been set to SAVE. It goes off during recording. When the tape is approaching its end, it flashes in tandem with the warning alarm that sounds when tape-end is approaching.

MIC/AUDIO screen

The MIC/AUDIO settings are performed on this screen.

Item	Variable range	VF display	Remarks
FRONT MIC POWER	<u>ON</u> OFF	USER ENG	ON : The phantom power is supplied to the front microphone. OFF : The phantom power is not supplied to the front microphone.
MIC LOWCUT CH1	<u>FRONT</u> <u>REAR</u> <u>F&R</u> OFF	USER ENG	For setting the high-pass filter for the CH1 mic input. FRONT: The high-pass filter for the front mic input is set to ON. REAR : The high-pass filter for the rear mic input is set to ON. F&R : The high-pass filters for both the front and rear mic inputs are set to ON. OFF : The high-pass filter for the CH1 input is set to OFF.

<Note>

The frequency characteristics in the MIC LOWCUT ON mode are 200 Hz to 10 kHz.

The underlining in the variable range column indicates the setting in the preset mode.

Setting menu screens VTR MAIN MENU

MIC/AUDIO screen

Item	Variable range	VF display	Remarks
MIC LOWCUT CH2	FRONT REAR F&R <u>OFF</u>	USER ENG	For setting the high-pass filter for the CH2 mic input. FRONT: The high-pass filter for the front mic input is set to ON. REAR : The high-pass filter for the rear mic input is set to ON. F&R : The high-pass filters for both the front and rear mic inputs are set to ON. OFF : The high-pass filter for the CH2 input is set to OFF.
LIMITER	ON <u>OFF</u>	USER ENG	For switching the audio limiter to ON or OFF. ON : The limiter operates. OFF : The limiter does not operate.
TEST TONE	<u>NORMAL</u> ALWAYS OFF CHSEL	USER ENG	NORMAL: The test tone signal is output when the AUDIO IN switch for CH1 is set to front while BAR is selected as the CAM/BAR switch setting. ALWAYS: The test tone signal is always output when BAR is selected as the CAM/BAR switch setting. OFF: The test tone signal is not output. CHSEL: The test tone signal is output for the selected channel when the AUDIO IN switch CH1 or CH2 is set to front while BAR is selected as the CAM/BAR switch setting.

<Note>

The frequency characteristics in the MIC LOWCUT ON mode are 200 Hz to 10 kHz.

Item	Variable range	VF display	Remarks
REC CH3/CH4	<u>CH1/2</u> CH3/4	USER ENG	For setting the audio signals to be recorded on the CH3 track and CH4 track. CH1/2: The CH1 signal is recorded on the CH3 track, and the CH2 signal is recorded on the CH4 track. CH3/4: The CH3 and CH4 signals which are supplied from the camera adapter are recorded.
CUE SELECT	<u>SIDE SW</u> CH1 CH2 MIX	USER ENG	For setting the audio signals to be recorded on the cue track. SIDE SW: The signals selected by the CUE switch on the side panel are recorded. CH1: The CH1 signals are recorded. CH2: The CH2 signals are recorded. MIX: The CH1 and CH2 mixed signals are recorded.
CUE REC	<u>ON</u> OFF	USER ENG	For setting whether signals are to be recorded on the cue track. ON : The signals will be recorded on the cue track. OFF : The signals will not be recorded on the cue track. The power-saving mode is established.
EMBEDDED AUDIO (60 Hz)	ON <u>OFF</u>	USER ENG	For setting whether the embedded audio signals are to be output to the HD SDI OUT connector when 60.00 Hz has been selected as the frame frequency setting. ON : The embedded audio signals are output. OFF : The embedded audio signals are not output.

The underlining in the variable range column indicates the setting in the preset mode.

Setting menu screens VTR MAIN MENU

TC/UB screen

The time code and user's bit settings are performed on this screen.

Item	Variable range	VF display	Remarks
TC MODE	DF <u>NDF</u>	USER ENG	For setting the time code to the DF or NDF mode. DF : The time code is set to the drop frame mode. NDF : The time code is set to the non-drop frame mode. <Note> This unit will perform the processing in the non-drop frame mode when the frame rate has been set to 24 fps.
UB MODE	<u>USER</u> DATE TIME EXT TCG	USER ENG	For setting what is to be written as the user's bit in the LTC area. USER : User setting (fixed). DATE : Real time value for year/month/day/hours. TIME : Real time value for hours/minutes/seconds. EXT : The UBG value is slave-locked when a TC signal is supplied from an external source. (The user setting is used when no external input is supplied.) TCG : Time code generator value <Note> Set the time on the TIME/DATE menu screen when using the UB MODE item with real-time operation.

Item	Variable range	VF display	Remarks
TCG SET HOLD	ON <u>OFF</u>	USER ENG	For selecting the operation of TCG when the TCG SET → power OFF → power ON → REC operations are performed. ON : The TCG setting is stored when the power is turned off, and is not regenerated. OFF : The TCG setting is not stored when the power is turned off, but is regenerated.
FIRST REC TC	<u>REGEN</u> PRESET	USER ENG	For setting the TC REGEN mode when recording is started. REGEN : The time code set on the tape is regenerated. However, when the frame rate has been set to 24 fps, the time code on the tape in those parts where the drop frame mode was established will not be regenerated. PRESET : The time code set on the tape is not regenerated. However, it is forcibly regenerated when the unit is transferred from the rec-pause mode to the recording mode.

<Note>

When USER is set for the UB MODE item, it is not possible to set EXT for the VITC UB MODE item. Similarly, it is not possible to set EXT for the UB MODE item when USER has been set for the VITC UB MODE item.

The underlining in the variable range column indicates the setting in the preset mode.

This unit automatically stores as the tape management information both the frame rate information which indicates the shooting speed and the active frame information which indicates the first frame where the frame image was switched in the user's bit of the sub-code track area (this used to be the LTC area). This information is output from the TC OUT connector and HD SDI OUT connector. Further, the active frame information is stored in the least significant digit of the user's bit while the frame rate information is stored in its lower third and fourth digits.

<Notes>

- When "DATE," "TCG" or "USER" has been selected as the UB MODE item setting on the TC/UB screen, the tape management information is output from the least significant digit to the lower fourth digit of the user's bit, so no other user's bit information will be output.
- The tape management information is not output as the user's bit information in the VIDEO AUX area (this used to be the VITC area).

Setting menu screens VTR MAIN MENU

TC/UB screen

The time code and user's bit settings are performed on this screen.

Item	Variable range	VF display	Remarks
P. OFF LCD DISPLAY	<u>ON</u> OFF	USER ENG	For setting whether the LCD display is to appear when the power is OFF. ON : The LCD display appears even when the power is OFF. OFF : The LCD display does not appear when the power is OFF. The power-saving mode is established.
TC OUT	<u>TCG</u> TCG/TCR	USER ENG	For selecting the time code which is to be output to the time code output connector. TCG : The time code generated by the time code generator is output at all times. TCG/TCR : The time code generated by the time code generator is output in the E-E mode; the time code reader value is output in the V-V mode.

Item	Variable range	VF display	Remarks
VITC UB MODE	USER DATE <u>TIME</u> EXT TCG	USER ENG	For setting what is to be written as the user's bit in the VITC area. USER : User setting (fixed). DATE : Real time value for year/month/day/hours. TIME : Real time value for hours/minutes/seconds. EXT : The UBG value is slave-locked when a TC signal is supplied from an external source. (The user setting is used when no external input is supplied.) TCG : Time code generator value <Notes> <ul style="list-style-type: none"> Set the time on the TIME/DATE menu screen when using the UB MODE item with real-time operation. The tape management information is not output as the user's bit information in the VITC area.
TC DISP SEL	<u>24F</u> 25F 30F	USER ENG	For setting the number of frames to be displayed per second in the time code frame digits. 24F : 0 to 23 frames will be displayed per second. 25F : 0 to 24 frames will be displayed per second. 30F : 0 to 29 frames will be displayed per second.

The underlining in the variable range column indicates the setting in the preset mode.

Setting menu screens VTR MAIN MENU

TIME DATE screen

The time/date settings are performed on this screen.

Item	Variable range	VF display	Remarks
YEAR	00— <u>02</u> —99	ENG	For setting the year.
MONTH	<u>1</u> —12	ENG	For setting the month.
DAY	<u>1</u> —31	ENG	For setting the day.
HOUR	<u>0</u> —23	ENG	For setting the hours.
MINUTE	<u>0</u> —59	ENG	For setting the minutes.
■ TIME/DATE SET	——	ENG	For entering the time and date.

VTR INITIALIZE screen

The VTR MENU settings are initialized and the user data is saved on this screen.

Item	Variable range	VF display	Remarks
READ FACTORY DATA	——	ENG	For returning the menu data to the factory settings.
WRITE VTR USER DATA	——	ENG	For saving the VTR MENU data inherent to the user into the unit's memory.

VTR USER MENU SELECT screen

This is the index screen for opening the screens containing the items to be registered on the VTR unit's USER MENU.

SUB menu	VF display	Remarks
FUNCTION	ENG	Index for opening the FUNCTION screen.
BATTERY/TAPE	ENG	Index for opening the BATTERY/TAPE screen.
VTR VF INDICATOR	ENG	Index for opening the VTR VF INDICATOR screen.
MIC/AUDIO	ENG	Index for opening the MIC/AUDIO screen.
TC/UB	ENG	Index for opening the TC/UB screen.

DIAGNOSTIC screen

The use statuses and software versions are displayed on this screen.

Item	Variable range	VF display	Remarks
OPERATION	——	ENG	Operating time with power ON.
DRUM RUNNING	——	ENG	Number of hours the drum has rotated.
THREADING	——	ENG	Number of times tapes have been loaded.
VTR SYSCON	——	ENG	For displaying the version of the system microcomputer.
SERVO	——	ENG	For displaying the version of the servo microcomputer.
MECHACON	——	ENG	For displaying the version of the mechanism control microcomputer.
FRONT	——	ENG	For displaying the version of the LCD panel drive microcomputer.

VTR CARD READ/WRITE screen

The settings for saving the menu data onto the setup card and loading the data from it are performed on this screen.

Item	Variable range	VF display	Remarks
READ	——	ENG	For loading the VTR data from the setup card.
WRITE	——	ENG	For saving the VTR data onto the setup card.
READ USER DATA	——	ENG	For loading the VTR user area data contained in the unit's internal memory.

The underlining in the variable range column indicates the setting in the preset mode.

Setting menu screens VTR USER MENU SELECT

ON (*) or OFF (●) is set on this screen to determine which items are to be registered on the USER MENU screen.

The maximum number of VTR unit items which can be registered is 14.

FUNCTION screen

Item	Variable range	VF display	Remarks
NEWS REC MODE	* ● —	ENG	For setting the registration of the NEWS REC MODE item on the USER MENU screen.
HUMID OPE	* ● —	ENG	For setting the registration of the HUMID OPE item on the USER MENU screen.
REC START	* ● —	ENG	For setting the registration of the REC START item on the USER MENU screen.
PAUSE TIMER	* ● —	ENG	For setting the registration of the PAUSE TIMER item on the USER MENU screen.
RETAKE MODE	* ● —	ENG	For setting the registration of the RETAKE MODE item on the USER MENU screen.
HD SDI OUT	* ● —	ENG	For setting the registration of the HD SDI OUT item on the USER MENU screen.
INTERVAL REC MODE	* ● —	ENG	For setting the registration of the INTERVAL REC MODE item on the USER MENU screen.
INTERVAL REC TIME	* ● —	ENG	For setting the registration of the INTERVAL REC TIME item on the USER MENU screen.
INTERVAL PAUSE TIME	* ● —	ENG	For setting the registration of the INTERVAL PAUSE TIME item on the USER MENU screen.
ECU REC CHK SW	* ● —	ENG	For setting the registration of the ECU REC CHK SW item on the USER MENU screen.
CHARACTER ON SDI	* ● —	ENG	For setting the registration of the CHARACTER ON SDI item on the USER MENU screen.

BATTERY/TAPE screen

Item	Variable range	VF display	Remarks
BATTERY SELECT	* ● —	ENG	For setting the registration of the BATTERY SELECT item on the USER MENU screen.
EXT DC IN SELECT	* ● —	ENG	For setting the registration of the EXT DC IN SELECT item on the USER MENU screen.
BATT NEAR END ALARM	* ● —	ENG	For setting the registration of the BATT NEAR END ALARM item on the USER MENU screen.
BATT NEAR END CANCEL	* ● —	ENG	For setting the registration of the BATT NEAR END CANCEL item on the USER MENU screen.
BATT END ALARM	* ● —	ENG	For setting the registration of the BATT END ALARM item on the USER MENU screen.
BATT REMAIN FULL	* ● —	ENG	For setting the registration of the BATT REMAIN FULL item on the USER MENU screen.
TAPE NEAR END ALARM	* ● —	ENG	For setting the registration of the TAPE NEAR END ALARM item on the USER MENU screen.
TAPE NEAR END TIME	* ● —	ENG	For setting the registration of the TAPE NEAR END TIME item on the USER MENU screen.
TAPE END ALARM	* ● —	ENG	For setting the registration of the TAPE END ALARM item on the USER MENU screen.
TAPE REMAIN /■	* ● —	ENG	For setting the registration of the TAPE REMAIN/■ item on the USER MENU screen.

The underlining in the variable range column indicates the setting in the preset mode.

Setting menu screens VTR USER MENU SELECT

ON (*) or OFF (●) is set on this screen to determine which items are to be registered on the USER MENU screen.

The maximum number of VTR unit items which can be registered is 14.

VTR VF INDICATOR screen

Item	Variable range	VF display	Remarks
TAPE (IND)	* ●	ENG	For setting the registration of the TAPE (VF INDICATOR) item on the USER MENU screen.
BATTERY (IND)	* ●	ENG	For setting the registration of the BATTERY (VF INDICATOR) item on the USER MENU screen.
LEVEL METER (IND)	* ●	ENG	For setting the registration of the LEVEL METER (VF INDICATOR) item on the USER MENU screen.
AUDIO IN (IND)	* ●	ENG	For setting the registration of the AUDIO IN (VF INDICATOR) item on the USER MENU screen.
TC (IND)	* ●	ENG	For setting the registration of the TC (VF INDICATOR) item on the USER MENU screen.
VTR WARNING (IND)	* ●	ENG	For setting the registration of the VTR WARNING (VF INDICATOR) item on the USER MENU screen.
SAVE LED	* ●	ENG	For setting the registration of the SAVE LED item on the USER MENU screen.

MIC/AUDIO screen

Item	Variable range	VF display	Remarks
REC CH3/CH4	* ●	ENG	For setting the registration of the REC CH3/CH4 item on the USER MENU screen.
CUE SELECT	* ●	ENG	For setting the registration of the CUE SELECT item on the USER MENU screen.
CUE REC	* ●	ENG	For setting the registration of the CUE REC item on the USER MENU screen.
EMBEDDED AUDIO (60Hz)	* ●	ENG	For setting the registration of the EMBEDDED AUDIO (60Hz) item on the USER MENU screen.

TC/UB screen

Item	Variable range	VF display	Remarks
TC MODE	* ●	ENG	For setting the registration of the TC MODE item on the USER MENU screen.
UB MODE	* ●	ENG	For setting the registration of the UB MODE item on the USER MENU screen.
TCG SET HOLD	* ●	ENG	For setting the registration of the TCG SET HOLD item on the USER MENU screen.
FIRST REC TC	* ●	ENG	For setting the registration of the FIRST REC TC item on the USER MENU screen.
P.OFF LCD DISPLAY	* ●	ENG	For setting the registration of the P.OFF LCD DISPLAY item on the USER MENU screen.
TC OUT	* ●	ENG	For setting the registration of the TC OUT item on the USER MENU screen.
VITC UB MODE	* ●	ENG	For setting the registration of the VITC UB MODE item on the USER MENU screen.
TC DISP SEL	* ●	ENG	For setting the registration of the TC DISP SEL item on the USER MENU screen.

MIC/AUDIO screen

Item	Variable range	VF display	Remarks
FRONT MIC POWER	* ●	ENG	For setting the registration of the FRONT MIC POWER item on the USER MENU screen.
MIC LOWCUT CH1	* ●	ENG	For setting the registration of the MIC LOWCUT CH1 item on the USER MENU screen.
MIC LOWCUT CH2	* ●	ENG	For setting the registration of the MIC LOWCUT CH2 item on the USER MENU screen.
LIMITER	* ●	ENG	For setting the registration of the LIMITER item on the USER MENU screen.
TEST TONE	* ●	ENG	For setting the registration of the TEST TONE item on the USER MENU screen.

The underlining in the variable range column indicates the setting in the preset mode.

Warning system

When a problem is detected immediately after the power is turned on or during operation, the user is alerted to the trouble by the display window (LCD), WARNING lamp and the lamps inside the viewfinder and also by warning tones heard from the speaker or earphone.

■ SLACK

LCD display	<ul style="list-style-type: none"> • The SLACK display flashes. • An error code is displayed where the time code is normally displayed.
WARNING lamp	The lamp flashes four times a second.
Tally lamp	The lamp flashes four times a second.
Warning alarm	The alarm sounds continuously.
Viewfinder	The SLACK display flashes.
What the warning indicates	The warning points to a problem in the tape take-up.
VTR unit's operation	The VTR unit stops. When a solenoid problem has been detected, the power is turned off. (The LCD warning display continues.)
Remedial action	Check the error code (see page 126) in the display window, and consult your nearest service centre.

■ RF

LCD display	The RF display flashes (during recording).
WARNING lamp	The lamp flashes four times a second (during recording).
Tally lamp	The lamp flashes four times a second (during recording).
Warning alarm	The alarm sounds four times a second (during recording).
Viewfinder	The RF display comes on (during recording).
What the warning indicates	The video heads are clogged. The warning points to a problem in the recording system.
VTR unit's operation	Head clogging is detected, and the alarm tone is sounded. The cleaning roller is activated and the heads are cleaned (for at least 10 seconds). Recording continues but the signals may not be recorded properly. The warning display is held until the rec-pause mode is established. It goes off as soon as the unit is transferred from the rec-pause mode.
Remedial action	Clean the heads. If the signals cannot be recorded properly after cleaning, turn off the power, and consult your nearest service centre.

■ REC WARNING

LCD display	"00:00:00:11" appears where the time code is normally displayed (for at least 5 seconds during recording).
WARNING lamp	The lamp flashes four times a second (for at least 3 seconds during recording).
Tally lamp	The lamp flashes four times a second (for at least 3 seconds during recording).
Warning alarm	The alarm sounds four times a second (for at least 3 seconds during recording).
Viewfinder	The REC WARNING display flashes (for at least 3 seconds during recording).
What the warning indicates	The warning points to a problem in the recording control signal.
VTR unit's operation	Recording continues but the signals may not be recorded properly while the warning is displayed.
Remedial action	The warning points to a problem with the control signal inside the unit. Consult your nearest service centre.

■ SERVO

LCD display	The SERVO display lights (during recording and playback).
WARNING lamp	The lamp flashes four times a second (during recording and playback).
Tally lamp	The lamp flashes four times a second (during recording and playback).
Warning alarm	The alarm sounds four times a second (during recording and playback).
Viewfinder	The SERVO display lights (during recording and playback).
What the warning indicates	The servo operation is disturbed.
VTR unit's operation	Operation continues but the unit may not operate properly.
Remedial action	Turn off the power, and consult your nearest service centre. When tape travel starts, the warning display may flash for a moment and go off: this is normal and not indicative of a malfunction.

Warning system

■ HUMID

LCD display	The HUMID display lights. The display will flash for 80 minutes after the condensation detection is released.
WARNING lamp	<ul style="list-style-type: none"> • The lamp lights when condensation has been detected. • The lamp will flash once a second after condensation detection is released.
Tally lamp	The lamp flashes four times a second.
Warning alarm	<ul style="list-style-type: none"> • During recording, the alarm sounds four times a second. • At all other times, the alarm sounds continuously.
Viewfinder	The HUMID display lights.
What the warning indicates	Condensation has formed.
VTR unit's operation	<p>The VTR unit's operation differs depending on the setting selected for HUMID OPE on the setting menu.</p> <ul style="list-style-type: none"> • When the ON setting has been selected, the VTR unit continues to operate. • When the OFF setting has been selected, the VTR unit continues with the recording, but this operation will stop if the tape sticks. <p>For 80 minutes after condensation detection is released, the drum will rotate however no other operation is possible.</p>
Remedial action	<p>Stop the tape travel, and turn off the power.</p> <p>If the HUMID display fails to go off even when the power is turned off and back on, wait until it goes off.</p>

■ TAPE NEAR END

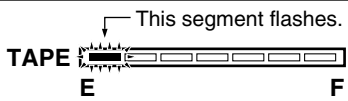
LCD display	
WARNING lamp	The lamp flashes once a second (during recording).
Tally lamp	The lamp flashes once a second (during recording).
Warning alarm	<p>The alarm sounds once a second (during recording).</p> <p>This can be switched on the setting menu.</p>
Viewfinder	<ul style="list-style-type: none"> • The remaining tape display flashes once a second (in the E-E mode). • The SAVE lamp flashes in tandem with the warning alarm (when SAVE&TAPE has been selected as the setting for the SAVE LED item on the VTR VF INDICATOR screen of VTR MENU). • "E" flashes once a second (three seconds during recording).
What the warning indicates	The tape is approaching its end.
VTR unit's operation	The VTR unit continues to operate.
Remedial action	Replace the cassette tape if necessary.

■ TAPE END

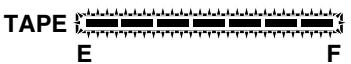
LCD display	<p>All the segments flash.</p> 
WARNING lamp	The lamp lights (during stop and in the standby OFF mode).
Tally lamp	The lamp flashes 4 times a second (during stop and in the standby OFF mode).
Warning alarm	The alarm sounds continuously (during stop and in the standby OFF mode).
Viewfinder	<ul style="list-style-type: none"> • The SAVE lamp flashes four times a second during stop and in the standby OFF mode (when SAVE&TAPE has been selected as the setting for the SAVE LED item on the VTR VF INDICATOR screen of VTR MENU). • "E" lights (during stop and in the standby OFF mode).
What the warning indicates	The tape has come to its end.
VTR unit's operation	If recording, playback or fast forwarding is in progress, the operation is stopped.
Remedial action	<p>Rewind the tape.</p> <p>Alternatively, replace the cassette tape.</p>

■ BATTERY NEAR END

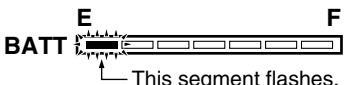
LCD display	
WARNING lamp	The lamp flashes once a second.
Tally lamp	The lamp flashes once a second.
Warning alarm	The alarm sounds four times a second.
Viewfinder	The BATT display flashes once a second.
What the warning indicates	The battery is near the end of its charge.
VTR unit's operation	The VTR unit continues to operate.
Remedial action	Replace the battery if necessary.

■ BATTERY END

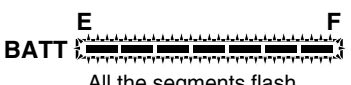
LCD display	
WARNING lamp	The lamp lights.
Tally lamp	The lamp flashes once a second.
Warning alarm	The alarm sounds continuously.
Viewfinder	The BATT display lights.
What the warning indicates	The battery is at the end of its charge.
VTR unit's operation	<p>All operation is stopped and the tape is unloaded.</p> <p>Only cassette eject operation is possible.</p>
Remedial action	Replace the battery.

Emergency eject

If the cassette cannot be ejected by pressing the EJECT button, use a screwdriver or similar tool to press and turn the EMERGENCY screw. This enables the cassette to be removed.

1 Set the power to OFF.

2 Remove the rubber cap where shown in the figure. Insert a Phillips head screwdriver into the cross-shaped part of the EMERGENCY screw (red).

4 Casette holder
1 Set the power to OFF.

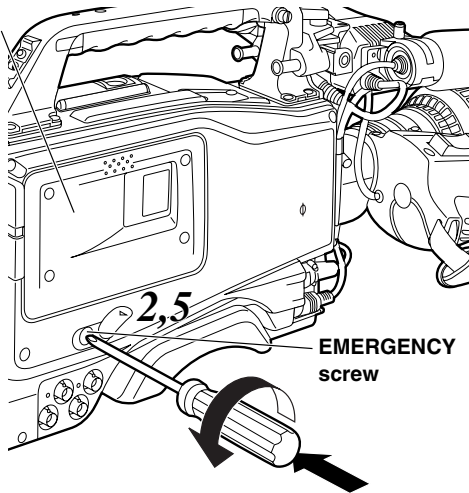

3 Push in and turn at the same time.

- This screw needs to be rotated through about 20 turns after the first turn until the unloading can be started.
- This screw needs to be rotated through about 90 turns after the first turn until the tape is ejected.

3 While pushing in with the screwdriver, turn the EMERGENCY screw counterclockwise until the tape is ejected.

- This screw needs to be rotated through about 20 turns after the first turn until the unloading can be started.
- This screw needs to be rotated through about 90 turns after the first turn until the tape is ejected.

4 Remove the cassette.

5 Return the rubber cap to its original position.

<Notes>

- Do not turn the EMERGENCY screw except in an emergency.
- Do not turn the screw clockwise. Stop turning the screw as soon as the tape is ejected. Otherwise, the mechanism may be damaged.
- After the tape is ejected, the cassette holder will not lock into place even when an attempt is made to close it. Be sure to turn the power off and turn it back on to reset the mechanism's operation, and then close the cassette holder.
- A clicking sound will be heard when the EMERGENCY screw is turned: this sound is made by the reel drive operation and is therefore not indicative of a malfunction.

Error codes

One of the following error codes appears in the display window when an error has occurred in the unit for some reason.

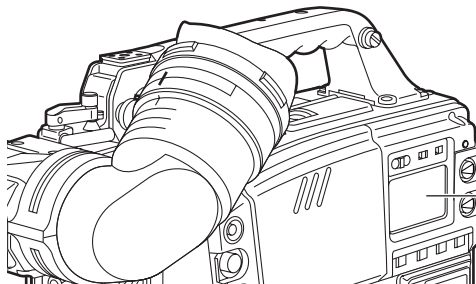

Code No.	Description of error
04	Pinch solenoid problem
08	Cleaning solenoid problem
0B	Supply reel problem
0C	Take-up reel problem
0D	Capstan problem
0E	Cylinder problem
0F	Loading problem
38	Servo transmission problem
3F	Camera transmission problem
6F	Reference signal problem
11	Video initialization problem

Maintenance

Condensation

The water vapor in the air may form as tiny droplets on the head drum when the unit is moved from a cold location to a warm location or used in a very humid place. This phenomenon is known as condensation, and running the tape under these conditions is liable to cause the tape to stick to the drum.

Note the following points:

- Remove the tape when the unit's operation is to be started in conditions where condensation may form.
- Before loading the tape, set the power switch to ON, and check that the HUMID display is not lit in the display window.

<Note>

For safety reasons, the HUMID display will flash and the drum will rotate for 80 minutes after condensation detection is released.

During this time, the operation buttons cannot be operated.

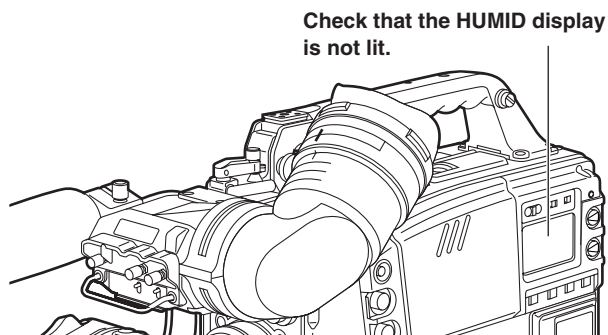

Head cleaning

Use the AJ-CL12LP cleaning cassette if the heads need to be cleaned. Take care to read the instructions accompanying the cleaning tape since the video heads may be damaged if the tape is not used in the correct way.

Cleaning inside the viewfinder

- Do not use thinners or any other solvent to remove dirt.
- Use a lens cleaner available on the market to wipe the lens.
- NEVER wipe the mirror.
If dirt or dust has found its way onto the mirror, remove it using an air blower available on the market.

Phenomena inherent to CCD cameras

Smear

This phenomenon may occur when very bright subjects are shot.

The faster the electronic shutter speed, the more likely that it will occur.

Replacing the backup battery

The backup battery is already installed when the unit is shipped.

When it has discharged, the "BACK UP BATT EMPTY" display appears for 3 seconds on the viewfinder screen when the POWER switch is set to ON.

Moreover, the time code value of the TCG will be set to "00:00:00:00" and the backup of the time code value will no longer be possible: this means that the backup battery should be replaced.

Consult with your nearest service centre, and replace the spent battery with a new battery (CR2032 or BR2032).

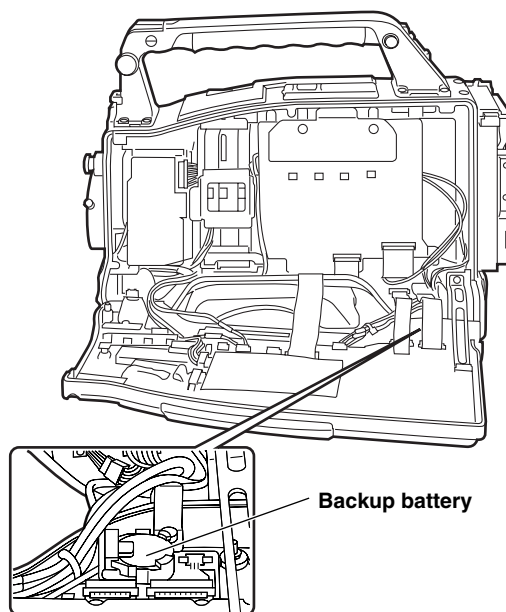

Inspections prior to shooting

Preparation for inspection

Perform the following inspections prior to shooting to check that the systems are operating properly. It is recommended that the images be checked using a colour monitor.

- 1** Insert a fully charged battery.
- 2** Set the POWER switch to ON, and check that the HUMID display has not come on and that at least 5 segments of the BATTERY display are lit.
 - If the HUMID display has come on, wait until it goes off.
 - If fewer than 5 segments of the BATTERY display have lit, replace the battery with one having an adequate charge.
- 3** After checking that there are no cables near the cassette holder or top panel, press the EJECT button to open the cassette holder.
- 4** After checking the following points, load the cassette tape and close the cassette holder.
 - The cassette tape must not be set to the accidental erasure prevention mode.
 - There must be no tape slack.

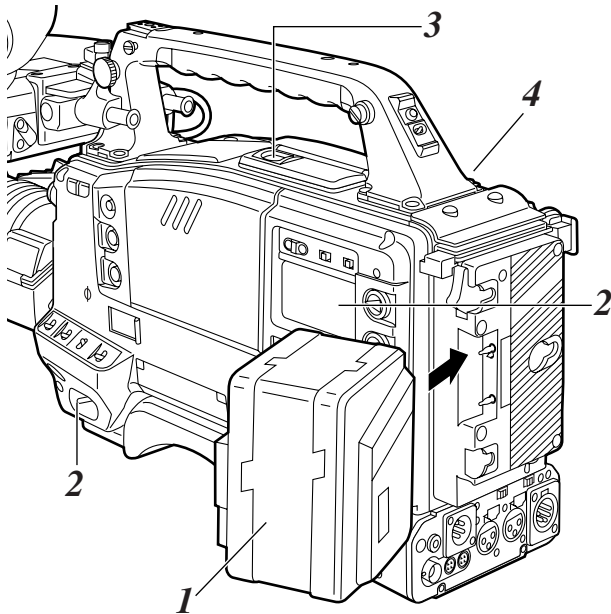

Inspecting the camera unit

Set the camera unit's switches as shown in the figure below.

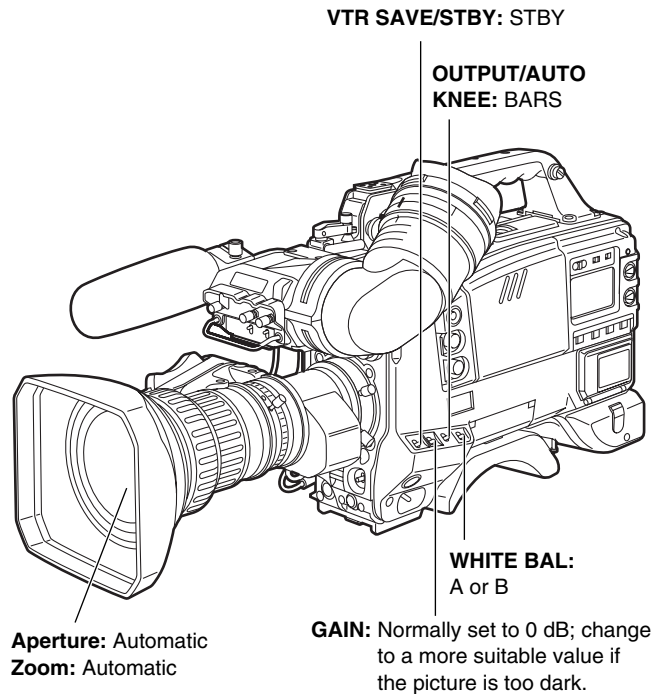

Inspections prior to shooting

Inspecting the viewfinder

- 1** Adjust the position of the viewfinder.
- 2** Check that the colour bar signals are displayed on the viewfinder screen, and adjust the BRIGHT, CONTRAST and PEAKING controls in such a way that the colour bar signals appear clearly on the viewfinder.
- 3** Check that the MENU screen is shown on the viewfinder screen and that the item settings can be changed by operating the MENU button or JOG dial button.
(Refer to pages 86 to 88 for the menu operations.)
- 4** Set the OUTPUT/AUTO KNEE switch to CAM, and select the settings for the CC and ND FILTER controls.
Check that the figures for the FILTER displays on the viewfinder screen change to reflect the changes in the control positions.
- 5** Take the following steps, and check that the  lamp lights when the items set to ON on the !LED screen of FILM (CAM) MAIN MENU 2 have been operated.
 1. Use the GAIN switch to set the gain to any value except 0 dB.
 2. Set the SHUTTER switch to ON.
 3. Set the WHITE BAL switch to PRST.
 4. Engage the lens extender.
 5. Set the FILTER controls to any setting except B.
- 6** Repeatedly press the SHUTTER switch from ON to SEL, and check that the shutter setting changes on the viewfinder screen.
- 7** Point the lens at any object, and turn the focus ring to bring the object into focus.
Check that an image of the object appears on the viewfinder.
- 8** Set both the AUDIO IN CH1 and CH2 switches to FRONT, and set LEVEL METER on the VTR VF INDICATOR screen of VTR MENU to CH1.
Check when sound is input from the microphone connected to the MIC IN jack on the lens that the audio level is displayed on the viewfinder screen.
Check when LEVEL METER on the VTR VF INDICATOR screen of VTR MENU is set to OFF that the audio level display is cleared from the viewfinder screen.
- 9** Check when the ZEBRA switch is set to ON that the zebra pattern appears on the viewfinder screen, and check when it is set to OFF that it is cleared from the screen.

<Note>

Depending on the setting statuses, the items and functions in steps **3** to **6** may not be displayed or they may not operate.

In a case like this, switch the unit to the engineer mode, set DISPLAY MODE on the menu's VF DISPLAY screen to "3," and set the necessary items on the SHUTTER SPEED, !LED and FILM (CAM) USER MENU SELECT 1, 2 and 3 screens.

Inspections prior to shooting

Inspecting the aperture and zoom functions

- 1** Set the zoom to the motorized zoom mode, and check its operations in this mode.
Check that the image changes when the zoom is set to the telephoto and wide-angle positions.
- 2** Set the zoom to the manual zoom mode, and check its operations in this mode.
Turn the manual zoom lever, and check that the image changes when the zoom is set to the telephoto and wide-angle positions.
- 3** Set the aperture to the auto adjustment mode, point the lens at some objects with different brightness levels, and check that the auto aperture adjustment works.
- 4** Set the aperture to the manual adjustment mode, turn the aperture ring, and check that the manual aperture is adjusted.
- 5** While holding down the auto instantaneous aperture adjustment button, point the lens at some objects with different brightness levels, and check that the auto instantaneous aperture adjustment function works.
- 6** Return the aperture to the auto adjustment mode, switch the GAIN switch setting to L, M and H, and check that:
 - The aperture is adjusted for objects of the same brightness level in tandem with the switching of the gain setting.
 - The gain displayed on the viewfinder screen is switched in tandem with the switching of the gain setting.
- 7** When a lens with an extender has been installed, set the extender to the operating position, and check that it works properly.

Inspecting the VTR unit

Perform all the steps outlined in section “1. Tape travel inspection” through section “4. Earphone and speaker inspection” one after the other.

1. Tape travel inspection

- 1** Set the VTR SAVE/STBY switch to SAVE, and check that the VTR SAVE lamp inside the viewfinder lights.
- 2** Set the VTR SAVE/STBY switch to STBY, and check that the VTR SAVE lamp goes off.
- 3** Set the TCG switch to R-RUN.
- 4** Set the DISPLAY switch to CTL.
- 5** Press the unit's VTR START button, and check that:
 - The tape reels rotate.
 - The figure shown on the counter display changes.
 - The REC lamp inside the viewfinder lights.
 - The RF and SERVO displays do not appear in the display window.
- 6** Press the unit's VTR START button again. Check that the tape stops and the REC lamp inside the viewfinder goes off.
- 7** Use the lens VTR button to check the same operations as in steps **5** and **6**.
- 8** Press the RESET button, and check that “00:00:00:00” appears on the counter display.
- 9** Set the LIGHT switch to ON, and check that the display window illuminates.
- 10** Press the REW button, and after the tape has been rewound for a few seconds, press the PLAY/PAUSE button.
Check that the tape is recorded, played back and rewound properly.
- 11** Press the FF button, and check that the tape is fast forwarded properly.

Inspections prior to shooting

Inspecting the VTR unit

2. Automatic audio level adjustment function inspection

- 1 Set the AUDIO SELECT CH1 and CH2 switch to AUTO.
- 2 Set the AUDIO IN CH1 and CH2 switches to FRONT.
- 3 Point the microphone connected to the MIC IN jack at a suitable sound source, and check that the changes in the level displays for both CH1 and CH2 reflect the changes in the strength of the sound.

3. Manual audio level adjustment function inspection

- 1 Set the AUDIO IN CH1 and CH2 switches to FRONT.
- 2 Set the AUDIO SELECT CH1 and CH2 switch to MAN.
- 3 Turn the AUDIO LEVEL CH1 and CH2 controls. Check that when they are turned clockwise, the level displays increase.

4. Earphone and speaker inspection

- 1 Set the VTR SAVE/STBY switch to STBY.
- 2 Turn the MONITOR control, and check that the speaker volume changes.
- 3 Connect the earphones to the PHONES jack. Check that the sound from the speaker is muted, and that the microphone's sound is heard in the earphones.
- 4 Turn the MONITOR control, and check that the earphone volume changes.

5. Inspection using external microphones

- 1 Connect external microphones to the AUDIO IN CH1 and CH2 jacks.
- 2 Set the AUDIO IN CH1 and CH2 switches to REAR.
- 3 Set the LINE/MIC/+48V selector switch on the back panel to MIC or +48V in accordance with the external mic's power supply type.
MIC : Internal power supply mic.
+48V : External power supply mic.
- 4 Point the microphones at the sound source, and check that the changes in the audio levels displayed on the audio level meter of the display window and in the viewfinder reflect the changes in the strength of the sound.
This inspection can also be performed for each channel by connecting one of the microphones to each channel in turn.

6. Inspections relating to the time code and user's bit

- 1 Set the user's bit as required.
For details on the setting procedure, refer to "Setting the user's bit" (page 65).
- 2 Set the time code.
For details on the setting procedure, refer to "Setting the time code" (page 66).
- 3 Set the TCG switch to R-RUN.
- 4 Press the VTR START button.
Check that the figure on the counter display changes as the tape travels.
- 5 Press the VTR START button again.
Check that the tape stops and the figure shown on the counter display stops changing.
- 6 Set the TCG switch to F-RUN.
Check that the figure on the counter display changes irrespective of the tape travel.
- 7 Set the DISPLAY switch to UB.
Check that the user's bit which has been set is displayed in the six higher digits in the internal colour bar signal recording mode.

Specifications

[GENERAL]

Supply voltage:

DC 12 V (DC 11 V—DC 17 V)

Power consumption:

39 W (maximum)

33 W (during SAVE REC mode)

 indicates safety information.

Ambient operating temperature:

0°C to +40°C

Storage temperature:

-20°C to +60°C

Ambient operating humidity:

Less than 85% (relative humidity)

Continuous operating time:

Approx. 62 minutes

(when using the 14/40W Anton/Bauer Trim pack)

Weight:

4.5 kg (main unit only)

Approx. 7.2 kg

(including main unit, viewfinder, lens, battery pack, tape and microphone)

Dimensions (W×H×D) (excluding grip):

132×204×330 mm

[CAMERA UNIT]

Pickup device:

2/3-inch, IT-type CCD with on-chip lens (1 million pixels)

System:

RGB 3-CCD system

Total number of pixels:

1370 (H) × 744 (V)

Number of effective pixels:

1280 (H) × 720 (V)

Quantizing:

10-bit non-linear

Digital signal processing:

74.1758 MHz (59.94 Hz)

74.25 MHz (60.00 Hz)

Horizontal drive frequency:

74.1758 MHz (59.94 Hz)

74.25 MHz (60.00 Hz)

Sensitivity:

F12 (2000 lux, 89.9% reflection, frame rate: 23.98 fps, synchro scan: 50%)

Minimum subject brightness:

0.7 lux (with F/1.4, +36 dB, frame rate: 59.94 fps)

Video S/N ratio:

54 dB (typ.)

Horizontal resolution:

More than 700 TV lines (centre)

Sampling frequency:

74.1758 MHz (59.94 Hz)

74.25 MHz (60.00 Hz)

Shutter speed:

Preset:

1/100, 1/120, 1/250, 1/500, 1/1000, 1/2000 sec.

Synchro scan:

0.8% to 97.2%

(aperture angle: 3 to 350 degrees)

Frame rate:

59.94 fps to 3.996 fps (0.99 fps/step)

60 fps to 4 fps (1.0 fps/step)

Programmable gain:

Choice of 3 positions (L/M/H) from

-6/-3/0/3/6/9/12/18/24/30 dB

Super gain:

18/24/30/36 dB selectable

Built-in filters:

CC filter:

A: CROSS, B: 3200 K, C: 4300 K, D: 6300 K

ND filter:

1: CLEAR, 2: 1/4 ND, 3: 1/16 ND, 4: 1/64 ND

Lens mount:

2/3-inch, Bayonet type

Optical system:

F/1.4 prism system

Registration:

Less than 0.03% (entire range) (excluding lens distortion)

Specifications

[VTR UNIT]

VTR Tape Transport System

Tape used:

1/4-inch DVCPRO L-size cassette tape

Tape speed:

135.28 mm/sec. (59.94 Hz)

135.4154 mm/sec. (60.00 Hz)

Recording/playback time:

46 minutes (using AJ-HP46LP)

32 minutes (using AJ-HP32LP)

FF/REW time:

Approx. 3 minutes (using AJ-HP46LP)

VTR Video System

Sampling frequency:

Y : 74.1758 MHz (59.94 Hz)

74.25 MHz (60.00 Hz)

P_B/P_R : 37.0879 MHz (59.94 Hz)

37.125 MHz (60.00 Hz)

Quantizing:

8 bits

Video compression system:

DCT + variable-length code

Video compression ratio:

1/6.7

Error correction:

Reed-Solomon product code

Video recording bit rate:

100 Mbps

Video band:

Y : 20 MHz

P_B/P_R : 10 MHz

VTR Audio System

(during playback on standard player)

Sampling frequency:

48.0 kHz (59.94 Hz)

48.048 kHz (60.00 Hz)

synchronized with video

Quantizing:

16 bits

Frequency response:

20 Hz to 20 kHz ± 1.0 dB (at reference level)

Dynamic range:

More than 85 dB (at 1 kHz, AWTD)

Distortion:

Less than 0.1% (at 1 kHz, reference level)

Wow and flutter:

Below measurable limits

Head room:

18 dB

[Connector Section]

Input

MIC IN (XLR, 3-pin female):

−40 dBu (switchable to −50 dBu using internal switch)

Phantom +48 V supported

AUDIO IN CH1/CH2 (XLR×2, 3-pin female):

LINE/MIC/MIC+48V switching type

LINE : 0 dBu

MIC : −60 dBu

MIC+48V: Phantom +48V, −60 dBu

GENLOCK IN (BNC):

1.0 V [p-p] (tri-level sync pulse: ± 300 mV), 75 Ω

Compliant with SMPTE296M (analogue sync) standard

TC IN (BNC):

0.5 V—8 V [p-p], high impedance

Output

AUDIO OUT (XLR, 5-pin male):

0 dBu

PHONES:

Stereo mini jack

HD SDI OUT (BNC×2):

0.8 V [p-p], with switch function

TC OUT (BNC):

2.0 V [p-p], low impedance

Other

LENS (12-pin)**ECU (6-pin)****DC IN (XLR, 4-pin male):**

DC 12 V (DC 11 V—17 V)

DC OUT (4-pin):

DC 12 V (DC 11 V—17 V), 0.4 A (max.)

EVF (20-pin)

Specifications

[VIEWFINDER]

(Optional accessory: AJ-HVF27P)

CRT:

2.0-inch high-resolution monochrome tube

Video system:

720P/59.94 Hz

720P/60.00 Hz

External adjustment controls:

Controls:

BRIGHT, CONTRAST, PEAKING

Switches:

TALLY HIGH/OFF/LOW, ZEBRA ON/OFF

[ACCESSORIES]

Shoulder strap (× 1)

[RELATED COMPONENTS & PARTS]

Relating to power supply

Battery pack:

AU-BP402

Battery charger:

AG-B425 (for charging AU-BP402 battery pack)

Battery case:

AU-M402H

AC adapter:

AJ-B75

Viewfinder

2.0-inch viewfinder:

AJ-HVF27P

Relating to external VTRs

Extension control unit:

AJ-EC3

Audio components

Microphone kit:

AJ-MC700P

Mic holder:

AJ-MH700P

Wireless mic receiver:

WX-RJ700

Camera attachment:

WX-ZJ770

Maintenance products

Cleaning tape:

AJ-CL12LP

Soft carrying case:

AJ-SC900

Rain cover:

SHAN-RC700

Weight and dimensions indicated are approximate.
Specifications are subject to change without notice.

Panasonic Broadcast Europe

Panasonic Broadcast Europe Ltd

West Forest Gate, Wellington Road, Wokingham, Berkshire RG40 2AQ U.K. Tel: 0118 902 9200

Panasonic Broadcast Europe GmbH

Hagenauer Str. 43, 65203 Wiesbaden-Biebrich Deutschland Tel: 49-611-1816-0

Printed in Japan
VQT9707

F0402W  