

Panasonic®

Operating Instructions

Memory Card Camera Recorder



Model No. AJ-SPX900E

DVCPRO 50

DVCPRO

DV

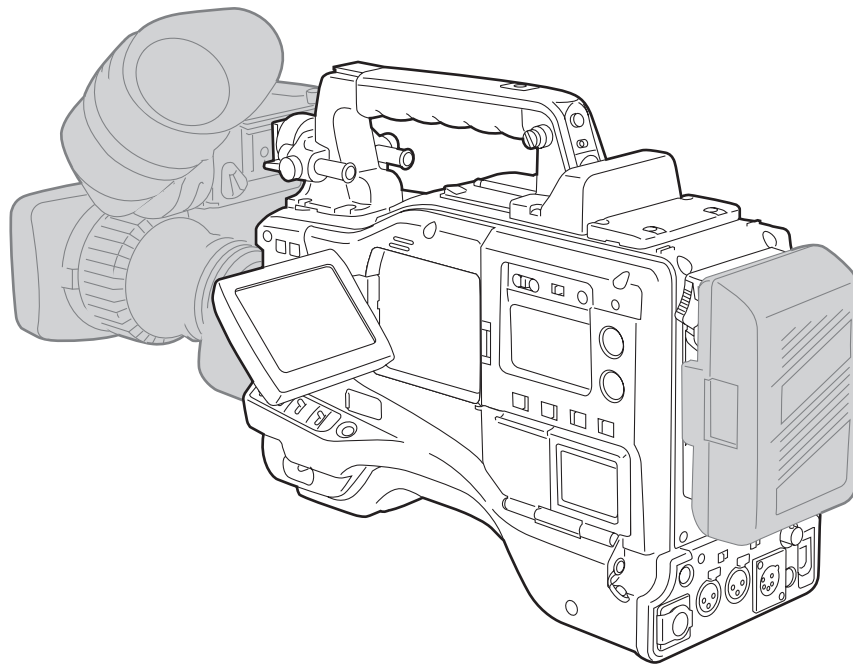

Before operating this product, please read the instructions carefully and save this manual for future use.

PLEASE NOTE:

- When preparing to record important images, always shoot some advance test footage, to verify that both pictures and sound are being recorded normally.
- Should video or audio recording fail due to a malfunction of this camera-recorder or the P2 cards used, we will not assume liability for such failure.

Software information for this product

1. Customer advisory: This product includes software licensed under the GNU General Public License (GPL) and GNU Lesser General Public License (LGPL); customers have the right to download, modify, and redistribute source code for this software.

Descriptions of the GPL and LGPL are stored on the installation CD included with this camera-recorder. See the folder named \LDOC. (The description is the original (written in English)). To download the relevant source code, visit <http://panasonic.biz/sav/>.

Please note that we cannot answer any questions you may have about the content, etc. of any source code you may obtain from the above Web site.

2. This product includes software licensed under the MIT License. A description of the MIT is stored on the installation CD included with this camera-recorder. See the folder named \LDOC. (The description is the original (written in English)).

-
- | |
|--|
| <ul style="list-style-type: none">● Unislot is a trademark of Ikegami Tsushinki Co., Ltd.● Other names of companies and products are trademarks or registered trademarks of the respective companies. |
|--|

Precautions for Use

■ DO NOT REMOVE PANEL COVERS BY UNSCREWING THEM.

To reduce the risk of electric shock, do not remove the covers. No user serviceable parts inside. Refer servicing to qualified service personnel.

CAUTION:

TO REDUCE THE RISK OF FIRE OR SHOCK HAZARD AND ANNOYING INTERFERENCE, USE THE RECOMMENDED ACCESSORIES ONLY.

CAUTION:

TO REDUCE THE RISK OF FIRE OR SHOCK HAZARD, REFER MOUNTING OF OPTIONAL INTERFACE BOARDS TO QUALIFIED SERVICE PERSONNEL.

WARNING:

- TO REDUCE THE RISK OF FIRE OR SHOCK HAZARD, DO NOT EXPOSE THIS EQUIPMENT TO RAIN OR MOISTURE.
- TO REDUCE THE RISK OF FIRE OR SHOCK HAZARD, KEEP THIS EQUIPMENT AWAY FROM ALL LIQUIDS. USE AND STORE ONLY IN LOCATIONS WHICH ARE NOT EXPOSED TO THE RISK OF DRIPPING OR SPLASHING LIQUIDS, AND DO NOT PLACE ANY LIQUID CONTAINERS ON TOP OF THE EQUIPMENT.

Lithium Battery

Warning

The lithium battery in this equipment must only be replaced by qualified personnel. When necessary, contact your local Panasonic supplier.

“The lithium battery is a critical component (type number CR2032 or BR2032 manufactured by Panasonic.)

It must never be subjected to excessive heat or discharge. It must therefore only be fitted in equipment designed specifically for its use.

Replacement batteries must be of the same type and manufacturer. They must be fitted in the same manner and location as the original battery, with the correct polarity connections observed.

Do not attempt to re-charge the old battery or re-use it for any other purpose. It should be disposed of in waste products destined for burial rather than incineration.”

CAUTION

Danger of explosion if battery is incorrectly replaced.

Replace only with the same or equivalent type recommended by the equipment manufacturer. Discard used batteries according to manufacturer's instructions.

VARNING

Explosionsfara vid felaktigt batteribyte. Använd samma batterityp eller en ekvivalent typ som rekommenderas av apparattillverkaren. Kassera använt batteri enligt fabrikantens instruktion.

ADVARSEL!

Eksplussionsfare ved fejlagtig håndtering. Udskiftning må kun ske med batteri af samme fabrikat og type. Levér det brugte batteri tilbage til leverandøren.

VAROITUS

Paristo voi räjähtää, jos se on virheellisesti asennettu.

Vaihda paristo ainoastaan laitevalmistajan suosittelemaan tyyppiin. Hävitä käytetty paristo valmistajan ohjeiden mukaisesti.

 indicates safety information.

Attention/Attentie

- Batteries are used for the main power source and memory back-up in the product. At the end of their useful life, you should not throw them away. Instead, hand them in as small chemical waste.
- Voor de primaire voeding en het reservegeheugen van het apparaat wordt gebruikgemaakt van een batterij. Wanneer de batterij is uitgeput, mag u deze niet gewoon weggooien, maar dient u deze als klein chemisch afval weg te doen.

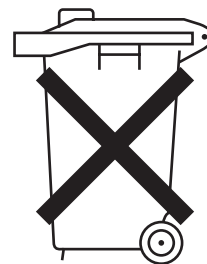

To remove the battery/Verwijderen van de batterij

Main Power Battery (Ni-Cd Battery)

Batterij Voor Primaire Voeding (Nikkelcadmiumbatterij)

Battery/Batterij BP-90 type

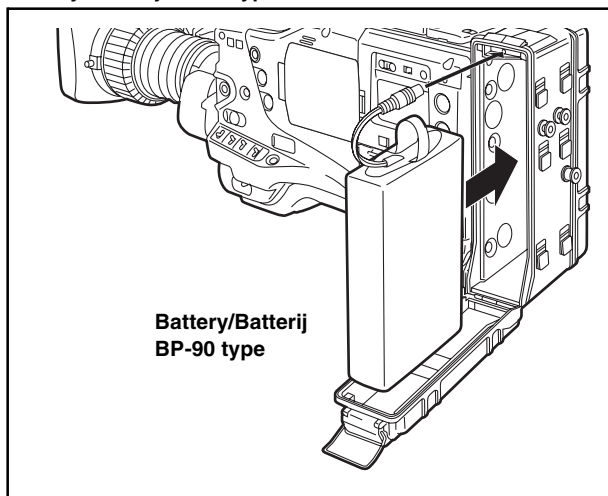

Battery/Batterij
BP-90 type

Anton/Bauer Battery
Anton/Bauer-Batterij

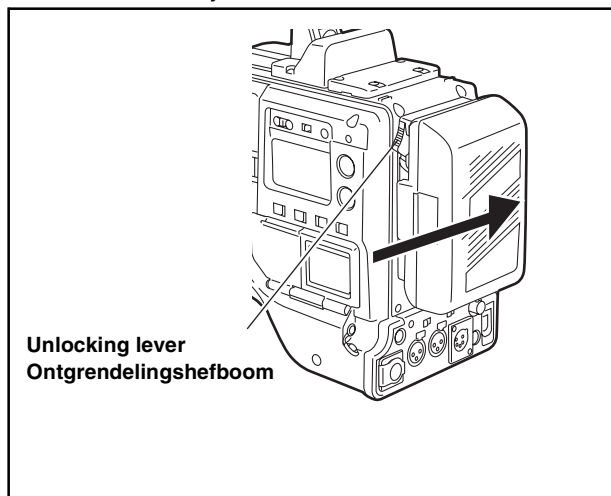

Unlocking lever
Ontgrendelingshefboom

- If a battery made by any other manufacturer is to be used, check the Operating Instructions accompanying the battery.
- In geval u een batterij van een anden fabrikant zou gebruiken, gelieve dan eerst zorgvuldig de gebruiksaanwijzing van deze batterij te lezen.

Back-up Battery (Lithium Battery)

Batterij Voor Reservegeheugen (Lithiumbatterij)

- For the removal of the battery for disposal at the end of its service life, please consult your dealer.
- Raadpleeg uw leverancier over de verwijdering van de batterij op het moment dat u het apparaat bij einde levensduur afdankt.

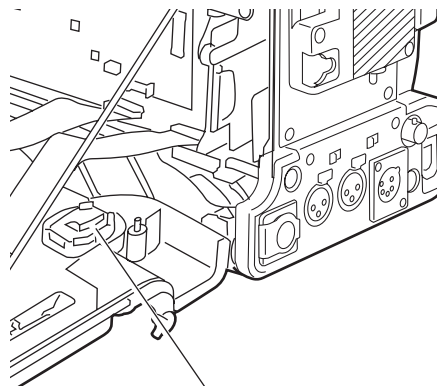

Back-up Battery (Lithium Battery)
Batterij Voor Reservegeheugen (Lithiumbatterij)

Contents

Precautions for Use	3
Chapter 1 Introduction	8
1-1 Camera Unit Features	8
1-2 Recorder/player Features	9
1-3 System Configuration	11
Chapter 2 Parts and their Functions ..	12
2-1 Power Supply and Accessory Mounting Section	12
2-2 Audio (input) Function Section	13
2-3 Audio (output) Function Section	14
2-4 Shooting and Recording/Playback Functions Section	15
2-5 Menu Operation Section	18
2-6 Time Code Section	19
2-7 Warning and Status Display Functions	20
2-8 Display Window Functions	20
2-9 LCD Monitor	21
2-10 Viewfinder	22
Chapter 3 Recording and Playback ...	23
3-1 P2 Cards	23
3-2 Basic Procedures	25
3-3 Normal Recording	27
3-4 PRE-RECORDING function	27
3-5 Loop Recording	28
3-6 INTERVAL REC	28
3-7 Recording Review Function	30
3-8 Normal and Variable Speed Playback	31
3-9 Voice Memo Function	31
3-10 Shot Mark Function	32
3-11 Recording Setting and Operation Mode	32
Chapter 4 Adjustments and Settings for Recording	33
4-1 Adjusting the White balance and Black Balance	33
4-1-1 Adjusting the White Balance	33
4-1-2 Adjusting the Black Balance	35
4-2 Setting the Electronic Shutter	36
4-2-1 Shutter Modes	36
4-2-2 Setting the Shutter Mode and Speed	36
4-2-3 Placing the Camera-recorder in SYNCHRO SCAN Mode	37
4-3 Selecting Recording Signals and Recording System	37
4-3-1 Selecting the Recording Signals	37
4-3-2 Selecting the Recording System	38
4-4 Selecting Audio Input Signals and Adjusting Recording Levels	38
4-4-1 Selecting Audio Input Signals	38
4-4-2 Adjusting Recording Levels	39
4-4-3 CH3 and CH4 Recording Levels	39
4-5 Setting Time Data	40
4-5-1 Setting the User Bits	40
4-5-2 Setting the Internal Clock's Date and Time	41
4-5-3 Setting the Time Code	42
4-5-4 Externally Locking the Time Code	42
4-5-5 Providing an ID to the Camera	44
4-5-6 Setting UMID Information	44
4-5-7 CTL Count Setting and Display	45
4-5-8 Mode Check Screen Displays (MODE CHECK button function)	45
4-6 Menu Displays in the Viewfinder Screen	46
4-6-1 Menu Configuration	46
4-6-2 Setting Menu Options	46
4-6-3 Selecting Options for USER MENU	47
4-7 Viewfinder Screen Status Displays	48
4-7-1 Lamps in the Viewfinder Screen	48
4-7-2 Viewfinder Status Indication Layout	48
4-7-3 Selecting Viewfinder Display Information	48
4-7-4 Display Modes and Setting Changes/adjustment Result Messages	54
4-7-5 Setting the Marker Displays	55
4-7-6 Marker Check Screen Displays (MARKER SELECT button function)	55
4-7-7 Checking Return Video Signal in the Viewfinder	55
4-8 Adjusting and setting the LCD monitor	56

4-9	Menu-driven Function Setup	57
4-9-1	Setting the Switchover of USER SW GAIN	57
4-9-2	Selecting Video Output Signals	57
4-9-3	Selecting Function for the FRONT AUDIO LEVEL Control	57
4-9-4	Assigning Functions to USER MAIN, USER1 and USER2 Buttons	58
4-9-5	Setting Color Temperature Manually	58
4-10	Handling data	59
4-10-1	Handling SD memory cards	59
4-10-2	Formatting, Writing and Reading an SD memory card	59
4-10-3	How to Use the User Data	63
4-10-4	How to Use Scene File Data	64
4-10-5	Resetting Menu Option Settings to Defaults	66
4-10-6	Lens File Data	66
Chapter 5	Preparation	67
5-1	Power Supply	67
5-1-1	Mounting the battery and setting the battery type	67
5-1-2	Using an AC Power Supply	70
5-2	Mounting the Viewfinder and Adjusting its Position	70
5-3	Mounting the lens and Performing the Flange Back and White Shading Adjustments	71
5-4	Preparing for Audio Input	75
5-4-1	When Using the Front Microphone	75
5-4-2	When Using a Wireless Receiver	75
5-4-3	When Using Audio Devices	76
5-5	Connection between the USB 2.0 port of the AJ-SPX900E and a PC	76
5-6	Mounting the Camera on a Tripod	77
5-7	Attaching the Shoulder Strap	78
5-8	Attaching the Rain Cover	78
5-9	Connecting the AJ-EC3E Extension Controller	78
5-10	Attaching the Front Audio Level Control Knob	79

Chapter 6	Manipulating Clips with Thumbnails	80
6-1	Thumbnail Manipulations Overview	80
6-2	Thumbnail Screen	81
6-3	Selecting Thumbnails	82
6-4	Playing Back Clips	82
6-5	Switching the Thumbnail Display	83
6-6	Shot Mark	83
6-7	Voice Memo	84
6-7-1	Playing Back Voice Memos	84
6-7-2	Recording a Voice Memo	84
6-7-3	Deleting Voice Memos	85
6-8	Deleting Clips	85
6-9	Restoring Clips	86
6-10	Reconnection of incomplete clips	86
6-11	Copying clips	86
6-12	Setting of Clip Meta Data	87
6-13	Setting of Proxy (optional)	88
6-14	Formatting a P2 Card	88
6-15	Formatting SD memory cards	89
6-16	Setting the Thumbnail Display Mode	89
6-17	Properties	90
6-17-1	Clip Property	90
6-17-2	P2 Card Status Display	90
6-17-3	SD memory card Status Display	91
6-17-4	Confirmation of Metadata Upload	91
6-17-5	Video Encoder Card Status Display (optional)	91
Chapter 7	Maintenance and Inspections	92
7-1	Inspections Before Shooting	92
7-1-1	Preparing for Inspections	92
7-1-2	Inspecting the Camera Unit	92
7-1-3	Inspecting the Memory Recording Functions	93
7-2	Maintenance	94
7-2-1	Cleaning Inside the Viewfinder	94
7-2-2	Phenomenon Inherent to CCD Cameras	94
7-2-3	Replacing the Backup Battery	94
7-2-4	Connector Signals	95
7-3	Warning System	96
7-3-1	Warning Description Tables	96
7-3-2	Error Codes	98

Chapter 8 Menu Description Tables . . . 99

8-1	Menu Configuration	99
8-2	SYSTEM SETTING	100
8-2-1	SYSTEM MODE	100
8-2-2	OPTION MODE 1	100
8-2-3	OPTION MODE 2	101
8-2-4	REC FUNCTION	101
8-2-5	OUTPUT SEL	102
8-2-6	LCD MONITOR	103
8-2-7	GENLOCK	103
8-3	PAINT	104
8-3-1	ROP	104
8-3-2	MATRIX	104
8-3-3	COLOR CORRECTION	105
8-3-4	LOW SETTING	105
8-3-5	MID SETTING	106
8-3-6	HIGH SETTING	106
8-3-7	ADDITIONAL DTL	107
8-3-8	SKIN TONE DTL	107
8-3-9	KNEE/LEVEL	108
8-3-10	GAMMA	108
8-3-11	FLARE	108
8-3-12	CAMERA SETTING	109
8-4	VF	109
8-4-1	VF DISPLAY	109
8-4-2	VF MARKER	110
8-4-3	USER BOX	110
8-4-4	VF INDICATOR1	110
8-4-5	VF INDICATOR2	111
8-4-6	MODE CHECK IND.	111
8-4-7	ILED	112
8-5	CAM OPERATION	112
8-5-1	CAMERA ID	112
8-5-2	SHUTTER SPEED	112
8-5-3	SHUTTER SELECT	113
8-5-4	USER SW	113
8-5-5	SW MODE	114
8-5-6	WHITE BALANCE MODE	114
8-5-7	USER SW GAIN	115
8-5-8	IRIS	115
8-6	MAIN OPERATION	116
8-6-1	BATTERY/P2CARD	116
8-6-2	BATTERY SETTING1	117
8-6-3	BATTERY SETTING2	118
8-6-4	MIC/AUDIO1	119
8-6-5	MIC/AUDIO2	119
8-6-6	TC/UB	120
8-6-7	UMID SET/INFO	120

8-7	FILE	121
8-7-1	SD CARD READ/WRITE	121
8-7-2	SD CARD R/W SELECT	121
8-7-3	LENS FILE	121
8-7-4	SCENE	121
8-7-5	INITIALIZE	121
8-8	MAINTENANCE	122
8-8-1	SYSTEM CHECK	122
8-8-2	LENS ADJ	122
8-8-3	BLACK SHADING	122
8-8-4	WHITE SHADING	122
8-8-5	DIAGNOSTIC1	122
8-8-6	DIAGNOSTIC2	123
8-8-7	HOURS METER	123
8-9	OPTION MENU	123
8-9-1	OPTION	123

Chapter 9 Connection with external unit 124

9-1	26-pin Connection with Pin Extenders	124
9-2	Connection with external VTR	124
9-3	Connection with Digital Triax	124

Chapter 10 Specifications 125

Chapter 1 Introduction

The AJ-SPX900E memory card camera-recorder integrates a camera unit equipped with three CCDs, incorporating a 2/3-inch on-chip lens featuring progressive drive technology, and a video recorder/player (VTR) that supports DVCPRO50, DVCPRO and DV formats.

The camera offers a choice of interlaced scanning and progressive scanning modes. The AJ-SPX900E provides for a wide range of uses, with such features as film-like gamma correction capability for authoring, and storage-type gain-up capability for news picture shooting.

Utilising P2 cards, which require no mechanism, as media, your AJ-SPX900E offers greater responsibility, operability, and portability. It is highly resistant to shock and vibration during recording, and therefore ensures stable operation for capturing quality video images under the most adverse conditions.

1-1 Camera Unit Features

■ Three CCDs with a 2/3-inch on-chip lens that supports progressive scanning

The camera supports aspect ratios of 16:9 and 4:3. Operators can choose between interlaced scanning and progressive scanning modes, to handle a wide range of applications.

In progressive scan mode, signals from and to the recorder/player are converted to interlaced signals.

■ Innovative 14-bit A/D Converted Digital Signal Processing Circuit

This model utilises new 14-bit linear A/D conversion technology to digitise video. The signal processor, operating at 36 MHz, provides finer reproduction of video, together with enhanced stability and reliability.

■ Storage-type Sensitivity Enhancement

The camera unit is equipped with a storage-type gain-up capability featuring progressive drive technology. This capability adds up to 20 dB to the standard gain increase.

■ Digital Zoom

The camera unit features progressive digital zoom. This is particularly effective when you want to zoom-in closer on the subject.

■ 12-axis Independent color Correction

Operating as a paint function, this capability independently corrects colors for each of the 12 axes. This feature helps to produce fine images.

■ Film-like Gamma Correction

This capability provides a choice of four gamma types. In addition to the standard mode, two types of film-like gammas are available to help enhance video expression in productions. The newly developed News Gamma accurately records changes in shadow areas and reduces whiteout in highlighted areas. This is particularly useful for on-site news shooting.

<Note>

While your AJ-SPX900E supports progressive scanning, constantly increasing the storage-type gain causes a slight degree of brightening at the upper left corner of the screen due to CCD characteristics. Note also that the dynamic range of video signals in progressive scanning mode is about half that in interlaced driving mode.

■ Auto White Balance with Automatic Tracking capability

The white balance is automatically adjusted in real time, according to the subject. This is effective for urgent recording, where you can't spare the time to make an adjustment through the auto white balance feature.

■ Data Management Capability

Your AJ-SPX900E has inbuilt data storage capacity for one user and four scene files. In addition, an SD memory card can be used as a setup card to store data for up to eight setups.

Regarding SD memory cards, please also see <Cautions in using SD memory cards> (page 18).

■ Customisable USER Buttons and USER MENU

The camera unit has three USER buttons, operable by a single press, to which frequently used function may be assigned. The on-screen menu is also customisable. You can create an original user menu screen by selecting frequently used menu items. The menu thus created can be displayed with a single touch of the MENU button.

■ MARKER SELECT Button

Your video camera-recorder has a button on the front that allows you to view marker information on the viewfinder screen. This is useful for checking the view angle during shooting.

■ Support for ECU

Your video camera-recorder supports the extension control unit AJ-EC3E.

1-2 Recorder/player Features

■ Multiple Slots

The AJ-SPX900E is equipped with five slots for P2 cards. Up to five cards may be inserted in these slots for continuous recording. They also provide new recording capabilities specific to memory cards.

● Hot-Swap recording

The Hot-Swap capability allows cards not in use to be replaced without interrupting recording. This facilitates continuous recording.

● Loop recording

The AJ-SPX900E can retain a certain amount of previously recorded material by continuously loop-recording data into a specified recording area.

● PRE-RECORDING function

In standby status, the AJ-SPX900E always stores video and sound input to the camera for up to 15 seconds (for the DVCPRO/DV format). This means that the PRE-RECORDING function, when turned on, records the video and sound for a preceding duration preset by the user. This feature recovers critical moments that you might have missed.

● INTERVAL REC/ONE SHOT REC

The AJ-SPX900E features interval recording at minimum one-frame intervals. This function is particularly suited to shooting science and nature programs. Frame-by-frame shooting is simple with the one-shot recording function.

● Proxy recording (when AJ-YAX800G attached)

By installing the optional video encoder card (AJ-YAX800G), MPEG4 format video and real-time metadata such as time code data can be recorded simultaneously on the P2 card and the SD memory card, together with the video and sound recorded by the camera. This function is useful for confirmation of editing of clips.

For more information about the approximate duration for proxy recording, see "Approximate Proxy Recording Time (optional) on SD memory cards". Please also see <Cautions in using SD memory cards> (page 18).

● Data protection

Data on P2 cards will not be lost due to overwriting unless the files are deleted or the cards are initialised. Recordings are written only to free space.

■ Format User-switchable Between DVCPRO50, DVCPRO and DV

Recorded video is compressed through a component digital recording method that uses a state-of-the-art compression technology, and sound is recorded using the non-compression PCM recording method, which excels in such areas as S/N ratio, frequency bands, waveform properties and reproducibility of fine areas. These methods further enhance the quality of images and sound.

The format is user-selectable, according to your purpose: e.g., DVCPRO50 for higher image quality, or DVCPRO for cost efficiency. DV format is also supported.

<Note>

When the clip is played back in the format not selected on the menu, the picture may be disturbed until the format is detected.

■ 4-channel Digital Audio Recording (all formats)

All formats - DVCPRO, DV and DVCPRO50 - support 4-channel digital audio recording with high-quality sound (48 kHz/16 bits).

■ Clip Thumbnailing

● Automatic generation of thumbnails

The AJ-SPX900E automatically generates a thumbnail for each recording cut (clip). It is possible to make use of this on the camera-recorder as well as for non-linear editing purposes, and after uploading to a server.

● Thumbnail display on the LCD monitor

The 3.5-inch color LCD side of the your video camera-recorder can provide a multi-screen view of 12 clip thumbnails. You can choose a desired clip to playback instantly.

● Seamless playback of selected clips

You can select more than one clip from the thumbnail view for continuous playback and output of seamless video.

<Note>

During continuous playback of clips in different recording formats, seamless playback may not be available.

● Display of clip information

By selecting clips, information added to clips, such as the recording time, Voice Memo, Shot Marks and metadata can be checked.

■ Voice Memos & Shot Marks

Each clip can incorporate comments, in the form of voice memos, associated with the time code, together with shot marks which, for example, can help you distinguish OK cuts from reject cuts.

Both voice memos and shot marks can be added to selected clips during and after a recording. This is helpful for editing recorded video.

■ Support for SDI Output (when AJ-YA902AG installed)

The AJ-SPX900E, when equipped with the extension board AJ-YA902AG, can output SDI signals from the VIDEO OUT connector.

■ Front-mounted Sound Level Control Mechanism

The AJ-SPX900E features a front-mounted control for fine adjustment of the sound recording level. This control is particularly effective for adjusting the sound level when you are shooting without a sound recordist. The control can be disabled.

■ Support for Built-in Unislot Wireless Receive

The AJ-SPX900E is designed to support an optional slot-in wireless receiver.

■ Recording Review Capability

This capability automatically plays back the last 2 to 10 seconds of recorded video, allowing you to quickly check the recorded contents.

■ Built-in Time Code Generator/reader

A special-purpose secondary code track can be used to record and reproduce time code information.

■ Support for Metadata

The AJ-SPX900E is capable of recording positional information (latitudes, longitudes and altitudes), as UMID information (metadata), from the GPS unit AJ-GPS900G (optional accessory). Names/titles can also be recorded, e.g. the camera person, the reporter, or the program which was registered on the SD memory card in advance. This information is also useful in managing information on clips. Regarding SD memory cards, please also see <Cautions in using SD memory cards> (page 18).

■ Features USB2.0 port

By connecting with a PC via USB2.0, a P2 card inserted in the AJ-SPX900E can be used as a bulk storage device.

■ DVCPRO/DV (IEEE1394 Digital input/output) connection (when AJ-YAD800G attached)

By attaching the optional IEEE1394 interface board (AJ-YAD800G), data can be input or output from a connected external IEEE1394 device.

■ Recording Time

Recording Time on P2 Cards (Number of cards used: 1)

Card No.	Recording Format	
	DVCPRO (Audio 2ch)	DVCPRO50 (Audio 4ch)
AJ-P2C002SG	Approx. 8 minutes	Approx. 4 minutes
AJ-P2C004HG	Approx. 16 minutes	Approx. 8 minutes

(For more information, see the instruction manual for the appropriate memory card.)

Approximate Proxy Recording Time (optional) on SD memory cards

Card No. (Card Capacity)	MPEG4 recording rate		
	192 kbps	768 kbps	1500 kbps
RP-SDH256N1A (256 MB)	Approx. 137 minutes	Approx. 35 minutes	Approx. 19 minutes
RP-SDH512N1A (512 MB)	Approx. 278 minutes	Approx. 71 minutes	Approx. 39 minutes
RP-SDK512J1A (512 MB)	Approx. 267 minutes	Approx. 69 minutes	Approx. 38 minutes
RP-SDH01GJ1A (1 GB)	Approx. 536 minutes	Approx. 139 minutes	Approx. 77 minutes
RP-SDK01GJ1A (1 GB)	Approx. 536 minutes	Approx. 139 minutes	Approx. 77 minutes

(Reference values when cards are used for continuous recording with our products. Actual recording time depends on the kind of scenes and the number of clips.)

1-3 System Configuration

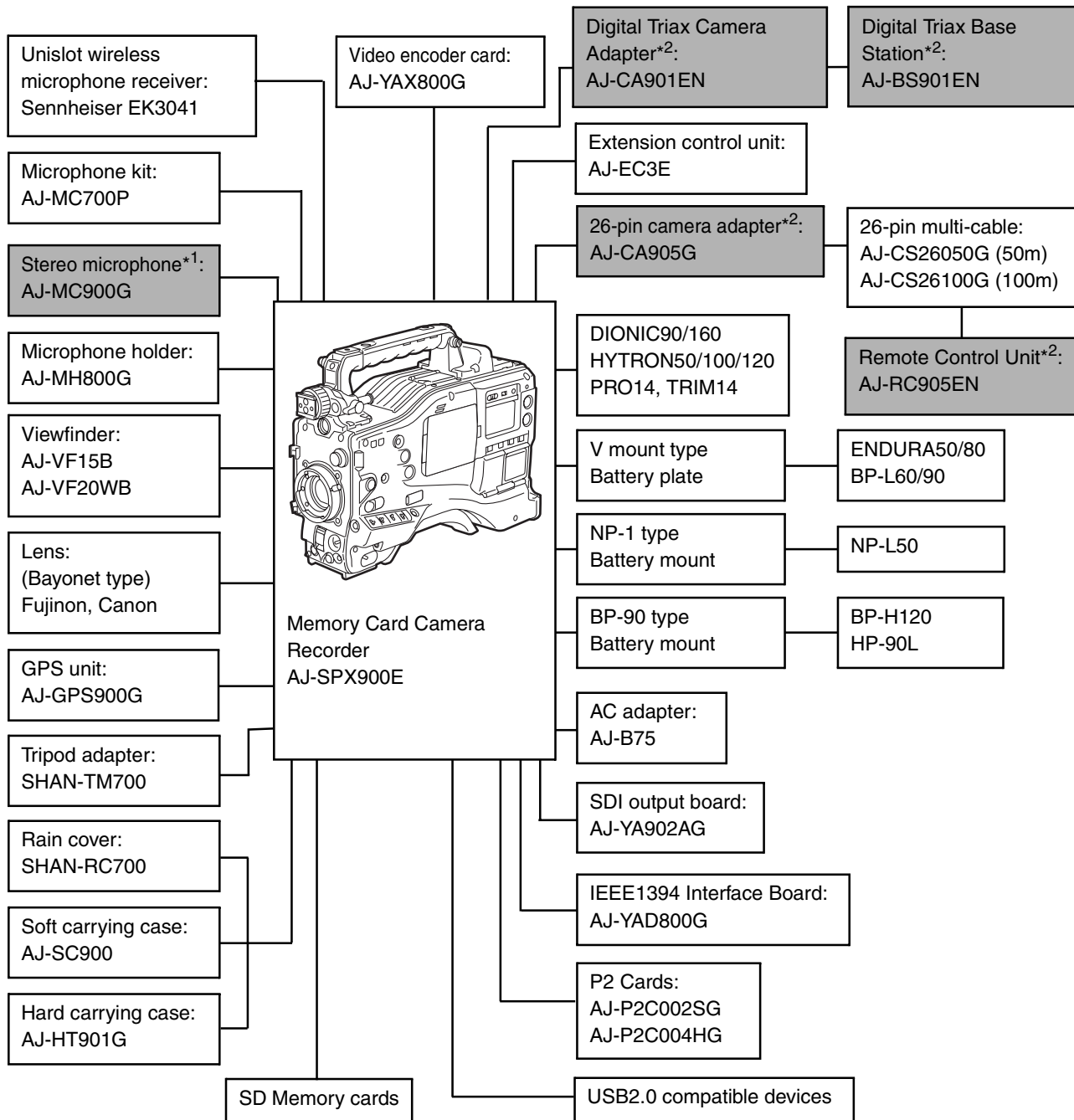

*1 To install a stereo microphone, an extra modification is required. For more information, contact your distributor or designated service provider.

*2 For using 26-pin extension devices or Digital Triax, contact your distributor or designated service provider.

Chapter 2 Parts and their Functions

2-1 Power Supply and Accessory Mounting Section

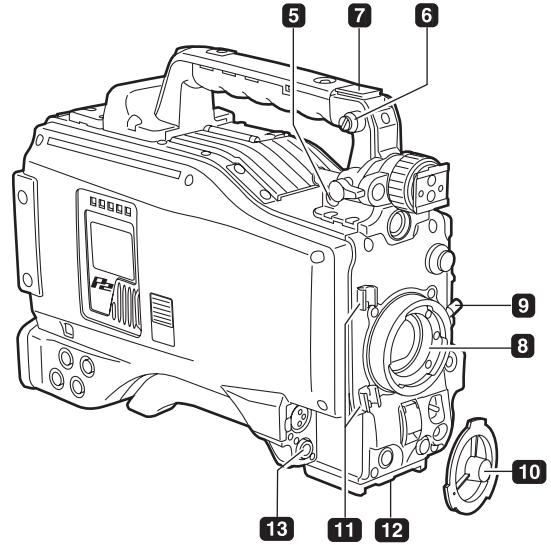
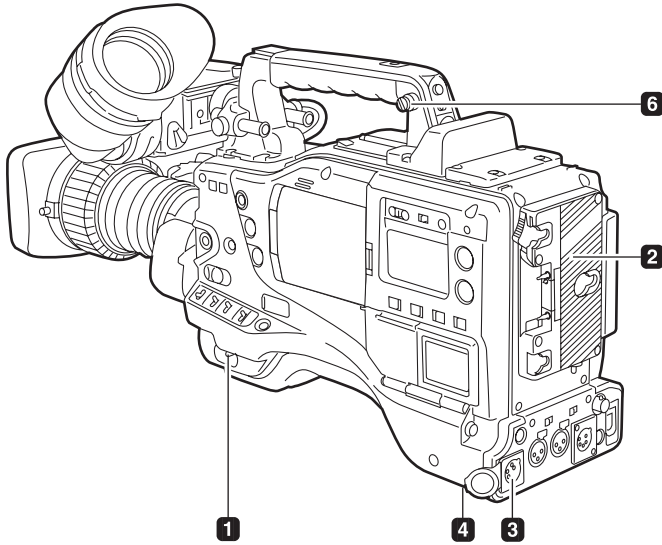

1 POWER switch

Used to turn on/off the power.

2 Battery mount

A battery pack from Anton/Bauer is mounted here.

3 DC IN (external power input) socket (XLR, 4P)

To operate your AJ-SPX900E on AC power, the AC adaptor AJ-B75 (optional accessory) must be connected to this socket.

4 BREAKER switch

When an excessive amount of current is fed through the video camera-recorder, due to any abnormal event, the breaker automatically turns off the power in order to protect the device.

After the interior of the video camera-recorder has been checked and/or repaired, this button must be depressed. If there is no unusual reaction, the unit can be powered-up.

5 GPS connector

This connects the optional GPS unit AJ-GPS900G.

6 Shoulder strap fittings

The shoulder strap is attached here.

7 Light shoe

A video light or similar accessory can be attached here.

8 Lens mount (bayonet type)

The lens is attached here.

9 Lens lever

Lower this lever to lock the lens to the lens mount.

10 Lens mount cap

To remove the cap, raise the **9** lens lever. When the lens is not mounted, replace the cap.

11 Lens cable/microphone cable clamp

This clamp secures the lens and microphone cables.

12 Tripod mount

When you want to mount the AJ-SPX900E on a tripod, the optional tripod adaptor (SHAN-TM700) is attached here.

13 LENS jack (12-pin)

The lens connection cord is connected here. For a detailed description of your lens, see the relevant manufacturer's instruction manual.

2-2 Audio (input) Function Section

2

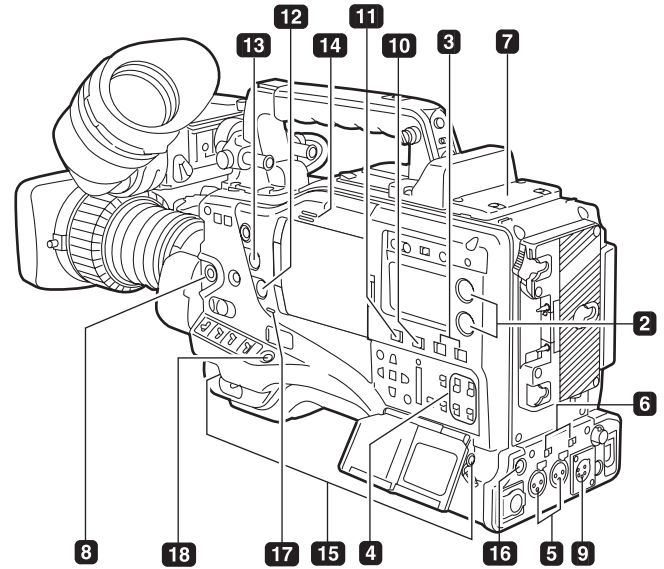
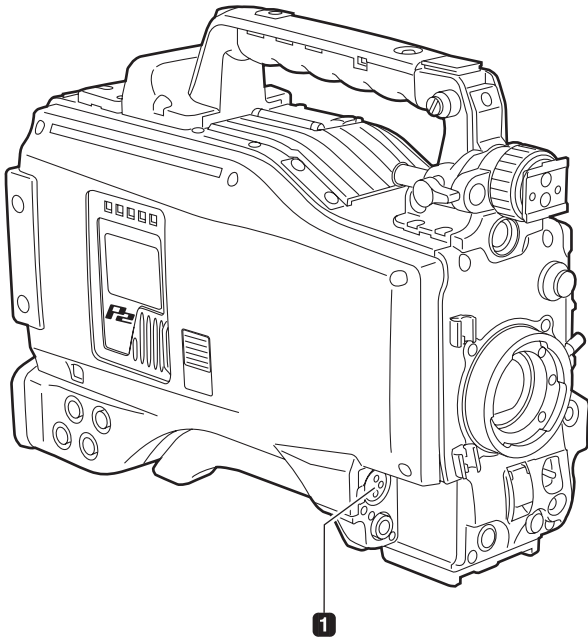

1 MIC IN (microphone input) jack (XLR, 3-pin)

A microphone (optional accessory) is connected here. Power for the microphone comes from this jack.

A remote microphone may be connected. In this case, the power supply to the appropriate connector must be enabled through menu option FRONT MIC POWER or REAR MIC POWER.

These options are found in the <MIC/AUDIO2> screen on the MAIN OPERATION page.

A stereo microphone may be connected, but you will need to replace the connector. For more information, contact your distributor or designated service provider.

2 AUDIO LEVEL CH1/CH2 (audio channel 1 & 2 recording level adjustment) controls

With the 3 AUDIO SELECT CH1/CH2 switch positioned to [MAN], these controls can be used to adjust the recording levels for Audio Channels 1/2.

Note that the controls are designed to be locked. For adjustment, each control must be depressed while turning.

3 AUDIO SELECT CH1/CH2 (audio channel 1 & 2 automatic/manual level adjustment selector) switch

Use this switch to select recording level control mode for Audio Channels 1 and 2.

AUTO: Recording level automatically controlled.

MAN: Recording level manually controlled.

4 AUDIO IN (audio input selector) switch

Use this switch to select the signals recorded through Audio Channels 1 - 4.

FRONT: Signal from the microphone connected to the 1 MIC IN jack is recorded.

W.L. (WIRELESS)

Signal from the slot-in wireless receiver is recorded.

REAR: Signal from the audio device connected to the 5 AUDIO IN CH1/CH2 connector is recorded.

<Note>

When you use stereo microphone (AJ-MC900G optional), set both CH1 and CH2 to [FRONT]. The signal from L CH is recorded to CH1 and that from R CH to CH2.

5 AUDIO IN CH1/CH2 (audio input channel 1 & 2) connectors (XLR, 3-pin)

Audio devices or a microphone may be connected here.

6 LINE/MIC/+48V (line input/mic input/mic input + 48V) selector switch

Used to select the audio signal input from the 5 AUDIO IN CH1/CH2 connectors.

LINE: Audio signal line-input from the audio device is input.

MIC: Audio signal from a self-powered (active) microphone is input. (The main unit does not supply power to the remote microphone).

+ 48V: Audio signal from a passive microphone is input. (The unit supplies power to the remote microphone).

7 Wireless slot

A Unislot wireless receiver (optional accessory) may be attached here.

8 FRONT AUDIO LEVEL (audio recording level adjustment) control

This control adjusts the recording levels for Audio Channels 1 and 2. Level adjustment does not depend on the position of the AUDIO SELECT switch.

The control can be enabled or disabled through the menu options FRONT VR CH1 or FRONT VR CH2. These options can be found in the <MIC/AUDIO1> screen on the MAIN OPERATION page.

2-3 Audio (output) Function Section

9 AUDIO OUT connector (XLR, 5-pin)

This connector outputs audio signals recorded on Channels 1/2 or 3/4.

Output signals are selected with the MONITOR SELECT CH1/2 / CH3/4 selector switch.

10 MONITOR SELECT (audio channel) CH1/2 / CH3/4 selector switch

Use this switch to select the audio channel whose signals are output to the speakers, earphones or AUDIO OUT connector.

CH1/2: Signals on Audio Channels 1 and 2 are output.

CH3/4: Signals on Audio Channels 3 and 4 are output.

The channel indications on the display window and on the audio level meter in the viewfinder are synchronised with this selector switch.

When a voice memo is being played back, the recorded voice is output to the speakers and earphones, regardless of the switch position.

11 MONITOR SELECT (audio selection) CH1/3 / ST / CH2/4 selector switch

The MONITOR SELECT switch is synchronised with the audio signal output to the speakers and earphones, and from the AUDIO OUT connector.

CH1/3: Signal on Audio Channel 1 or 3 is output.

ST: Stereo audio signals on Audio Channels 1 and 2 or Audio Channels 3 or 4 are output. The stereo signals can be changed to mixed signals using a menu option.

CH2/4: Signal on Audio Channel 2 or 4 is output.

Monitor switch	MONITOR SELECT switch	
	CH1/2	CH3/4
CH1/3	Audio Channel 1	Audio Channel 3
ST	Stereo signals from Audio Channels 1 and 2*	Stereo signals from Audio Channels 3 and 4*
CH2/4	Audio Channel 2	Audio Channel 4

* You can select between stereo and mixed signal types using the menu option MONITOR SELECT. This menu option can be found in the <MIC/AUDIO2> screen on the MAIN OPERATION page.

12 MONITOR (volume) control

Used to control the volume of sound output from the monitor speakers and earphones.

13 ALARM (warning alarm volume adjustment)

Used to control the volume of the warning sound emitted from 14 speakers or earphones connected to the 15 PHONES jack.

If the control is minimised, no alarm is audible.

14 Speakers

The speakers output EE sound during recording, and reproduced sound during playback.

The speakers emit an alarm sound when the warning lamp blinks and/or the indicator activates.

When the 15 PHONES jack is connected with earphones, sound from the speaker is automatically muted.

15 PHONES (earphones) jack (mini jack)

This connector is designed for audio monitoring (stereo) earphones. When earphones are connected, sound from the speakers is automatically muted.

Both the front and rear connectors output the same sound.

16 DC OUT (DC power supply) output socket

This output socket is designed for 12-VDC. It provides a maximum current of 1 A.

17 Voice memo microphone

Used to record a voice memo.

For more information on voice memos, see [3-9 Voice Memo Function].

18 VOICE MEMO button

Used to record a voice memo during recording or playback, or recording or playback is paused. Another press of the button stops voice memo recording.

2-4 Shooting and Recording/Playback Functions Section

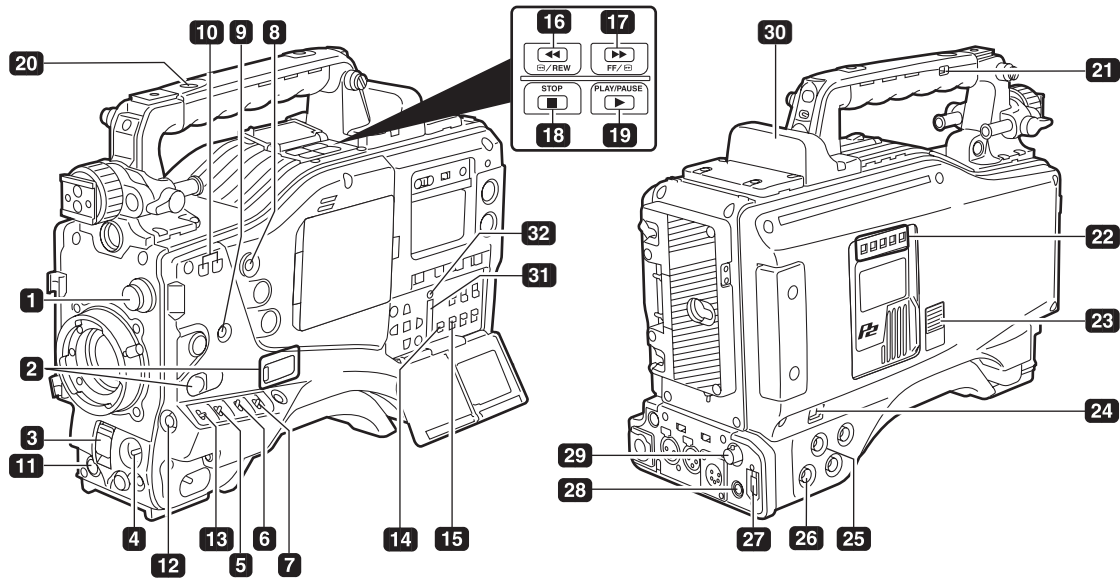

Shooting and Recording (camera unit)

1 CC FILTER/ND FILTER (filter selector) controls

Use this knob to select a filter depending on the luminance and color temperature of the subject.

CC FILTER knob (outside, large diameter)

A: Cross filter B: 3200 K
C: 4300 K D: 6300 K

ND FILTER knob (inside, small diameter)

1: CLEAR (transparent) 2: 1/4 ND
3: 1/16 ND 4: 1/64 ND

Examples of filter selection according to shooting conditions

Shooting conditions	CC FILTER	ND FILTER
Sunrise, sunset, studio	B (3200 K)	1 (CLEAR)
Clear outdoor environments	C (4300 K) or D (6300 K)	2 (1/4 ND) or 3 (1/16 ND)
Cloudy/rainy outdoor environments	D (6300 K)	1 (CLEAR) or 2 (1/4 ND)
Clear, bright scenes such as snowscape, high mountains, beaches, etc.	C (4300 K) or D (6300 K)	3 (1/16 ND) or 4 (1/64 ND)

2 USER MAIN, USER 1 and USER 2 buttons

These buttons can be assigned user-selected functions, using a menu option. Each button, when pressed, performs the assigned function.

For more information, see [4-9-4 Assigning Functions to USER MAIN, USER1 and USER2 Buttons].

3 SHUTTER switch

Used to enable or disable the electronic shutter.

OFF: Electronic shutter disabled.

ON: Electronic shutter enabled.

SEL: Used to change the speed of the electronic shutter.

This dial switch returns to its original position. Each turn of the switch alters the shutter speed.

For more information, see [4-2 Setting the Electronic Shutter].

4 AUTO W/B (white/black) BAL switch

AWB: White balance is automatically adjusted.

When the WHITE BAL switch on the side is positioned at [A] or [B], the adjusted value is stored in the memory.

However, if "VAR" is selected for the menu options AWB A and AWB B, the value set through the menu options is used, and this function does not work. Menu options can be found in the <WHITE BALANCE MODE> screen on the CAM OPERATION page.

Note also that when the switch is positioned at PRST this function does not work.

ABB: Back balance is automatically adjusted.

To automatically correct black shading, the AUTO W/B BAL switch must be pressed toward [ABB] for longer than five seconds.

<Note>

To stop automatic adjustment of the white or black balance in progress, set the switch to either ([AWB] or [ABB]).

If automatic adjustment is canceled, the value in effect before automatic adjustment will be used.

5 Gain selector switch

Use this switch to select video amplifier gain, according to lighting conditions under which you are shooting.

The values for L, M, and H can be preset using menu options.

These are factory-set to 0 dB for L, 9 dB for M, and 18 dB for H.

6 OUTPUT/AUTO KNEE selector switch

Used to select the video signals sent from the camera unit to the memory, viewfinder and video monitor.

CAM. AUTO KNEE ON:

Video being recorded through the camera is sent with the auto knee circuit activated.

CAM. AUTO KNEE OFF:

Video being recorded through the camera is sent in manual knee mode.

BARS:

Color bar signal is output. The auto knee circuit does not work.

You can select between four types of color bar signal. For more information, see [8-5-5 SW MODE].

Auto Knee function

Usually, when you adjust levels to shoot people or scenery against a strongly lighted background, the background will be totally whited-out, with buildings and other objects blurred. In this case, the auto knee function reproduces the background clearly. This function is effective when:

- The subject is a person positioned in the shade under a clear sky.
- The subject is a person inside a car or building, and you also want to capture the background visible through a window.
- The subject is a high-contrast scene.

7 WHITE BAL (white balance memory selector) switch

Used to select the white balance adjustment method.

PRST: Use this when you have no time to adjust the white balance.

The value for the white balance is factory-set to 3200 K.

It can be changed to any color temperature using a menu option. For more information, see [4-9-5 Setting Color Temperature Manually].

A or B: Pressing the **4** AUTO W/B BAL Switch toward [AWB] automatically adjusts the white balance, saving the adjusted value in Memory A or B. For more information, see [4-1-1 Adjusting the White Balance].

Your video camera-recorder is factory-set to save the adjusted value. Through a menu option, the auto-tracking white balance (ATW) can be assigned to B, or desired color temperatures can be assigned to A and B.

For more information, see [4-1-1 Adjusting the White Balance].

8 MODE CHECK button

Each press of this button changes the screen type in the viewfinder in the following order: STATUS, !LED, FUNCTION, AUDIO.

This does not affect the signal output from the camera.

9 MARKER SELECT button

This button selects the marker information indicated on the viewfinder screen. It switches between two marker information indications, which can be selected using a menu option. Pressing this button once switches the indicated marker information from A (Marker A) to B (Marker B), and pressing again switches B to OFF (no marker). When the power is turned on, the last selected indication before power-down appears.

For more information, see [4-7-6 Marker Check Screen Displays (MARKER SELECT button function)].

10 SYNCHRO SCAN ADJUSTMENT buttons

These buttons are enabled when the **3** shutter switch is positioned at [ON] and synchro scan is selected.

They are used to adjust the speed of the synchro scan.

The – button decreases shutter speed; the + button increases shutter speed.

If you shoot a PC monitor, for example, you should adjust shutter speed so that the horizontal bars in the viewfinder will produce less noise.

Shooting and Recording/Playback Function Section (recording)

11 REC START/STOP button

Pressing this button starts recording, pressing again stops recording.

This button has the same function as the **20** REC button on the handle and the VTR button at the lens.

12 SHOT MARK button

Pressing this button while recording adds a shot mark to the thumbnail of that clip. This button also adds a shot mark to any thumbnail selected on the LCD monitor.

For more information on shot marks, see [3-10 Shot Mark Function].

13 SAVE ON/OFF switch

Used to select the power supply method for each output section.

ON: The output selected through the menu option SAVE SW is power-saved. This option can be found on the OPTION MODE 1 screen on the SYSTEM SETTING page.

OFF: Power saving is canceled.

<Note>

During recording, this switch produces no effect. The power supply method is switched after recording is finished.

14 VIDEO OUT CHARACTER switch

This switch controls the superimposition of characters onto the video output from the VIDEO OUT connector.

ON: Characters are superimposed.

OFF: Characters are not superimposed.

For types of characters, see [4-9-2 Selecting Video Output Signals].

15 OUTPUT SEL (output signal selection) switch

Used to switch the signals output from the VIDEO OUT and MON OUT connectors.

MEM: In EE (recording) mode, video from the camera is output. In VV (playback) mode, playback signal from a P2 card is output.

CAM: Video from the camera is output constantly.

OFF: Video is not output, and the video camera-recorder operates in power-saving mode.

Note that the audio output is synchronised with the video. For types of video outputs, see [4-9-2 Selecting Video Output Signals].

<Notes>

- During recording, this switch does not switch output signals before stopping the recording operation.
- Even if this switch is set to "CAM", if "VIDEO" or "1394" is selected for REC SIGNAL the AJ-SPX900E performs the operation when "MEM" is selected. The menu option REC SIGNAL is found in the SYSTEM MODE screen on the SYSTEM SETTING page.

16 REW (rewind) button and lamp

During pause, this button performs a fast-reverse playback with the lamp blinking.

During playback, it performs an approximately 4× fast-reverse playback with the PLAY and REW lamps blinking. If this button is pressed when playback is paused, the start of the clip being played back is located in pause mode.

17 FF (fast forward) button and lamp

During pause, this button is used to perform fast playback with the lamp blinking.

During playback, it performs an approximately 4× fast playback with the PLAY and FF lamps blinking. If this button is pressed when playback is paused, the start of the next clip is located in pause mode.

18 STOP button

This button stops playback.

19 PLAY/PAUSE button

This button is used to view playback using the viewfinder screen or a color video monitor. The lamp comes on when playback starts.

In playback mode, this button pauses (PLAY PAUSE) playback with the lamp blinking.

20 REC button

Pressing this button starts recording, and pressing again stops recording.

This button has the same function as the **11** REC START/STOP button and the VTR button at the lens.

It may be disabled with the **21** recording protection button.

21 REC protection button

This button disables the **20** REC button on the handle.

ON: The REC button is enabled.

OFF: The REC button is disabled.

22 P2 CARD ACCESS LED

This LED indicates the recording and playback status of each card.

23 Slide lock button

Used to open the slide-out door for inserting P2 cards. While depressing this button, slide the door to the left.

24 USB 2.0 connector

A USB 2.0 cable is connected here.

When the menu option USB is set to "ON", data can be transferred via USB 2.0. During such data transfer, recording, playback or operations of clips is not permitted.

The menu option USB is found in the SYSTEM MODE screen on the SYSTEM SETTING page. For more information, see [5-5 Connection between the USB 2.0 port of the AJ-SPX900E and a PC].

25 GENLOCK IN connector

This connector is used to input a reference signal when the camera unit is gen-locked, or when the time code is externally locked. If VIDEO is selected for the menu option REC SIGNAL, the connector can be used to record actual signals. The menu option REC SIGNAL is found on the SYSTEM MODE screen on the SYSTEM SETTING page.

<Notes>

- The reference input signal must be a standard VBS (Video Burst Sync).
- If you need to synchronise the input signal with the AJ-SPX900E when "VIDEO" is selected for the REC SIGNAL, set the menu option GENLOCK to "EXT". The option GENLOCK is found on the GENLOCK screen, which is accessible from the SYSTEM SETTING page.

26 MON OUT (monitor output) connector

This connector outputs the video signal to the monitor. The video signals linked to the setting of the OUTPUT SEL switch are output from here. Through an internal menu option, the characters can be superimposed independently of the VIDEO OUT connector. For more information, see [4-9-2 Selecting Video Output Signals].

27 Connector cover

Remove the cover, and install the DVCPRO/DV connector. For directions on attaching the connector, see the instruction manual for the IEEE1394 interface board. (AJ-YAD800G, optional accessory)

28 ECU REMOTE (remote control) connector

The extension control unit AJ-EC3E (optional accessory) is connected here.

29 VIDEO OUT (video signal output) connector

This connector outputs video signals. The video signals linked to the setting of the OUTPUT SEL switch are output from here.

30 OPTION SLOT

Attach the video encoder card (AJ-YAX800G, optional). For information about the installation and proxy recording, see the AJ-YAX800G instruction manual.

2-5 Menu Operation Section

31 SD memory card insertion slot

An SD memory card (optional accessory) is inserted here. It is used for metadata upload and proxy recording (optional).

<Cautions in using SD memory cards>

SD memory cards used with the AJ-SPX900E should conform to SD standards. Be sure to format cards using the AJ-SPX900E. Cards formatted according to SD standards using PCs or other devices can be used.

SD memory cards with the following capacity (8MB - 1GB) can be used for the AJ-SPX900E:

8 MB	16 MB	32 MB	64 MB
128 MB	256 MB	512 MB	1 GB

For proxy recording (optional), high-speed SD memory cards (256MB, 512MB, and 1GB) should be used.

For the latest information on SD memory cards that can be used with the AJ-SPX900E, see the following support site:

<https://eww.pavc.panasonic.co.jp/pro-av/>

32 BUSY (operation mode display) lamp

This lamp indicates the active status of the SD memory card.

It stays illuminated when the card is active.

<Note>

While the lamp is on, do not insert or remove the card.

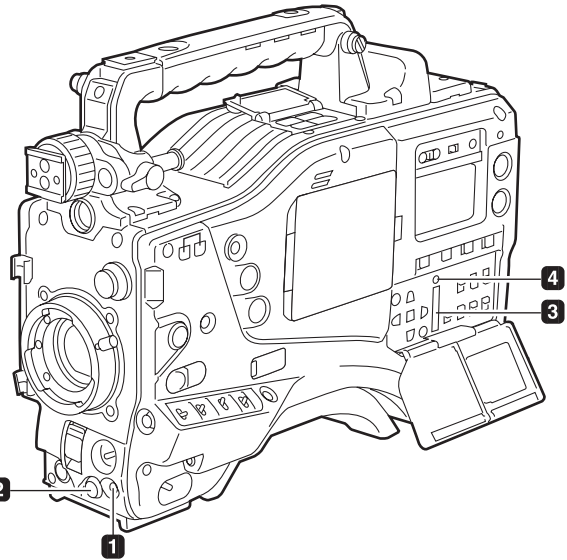

1 MENU button

Used to turn on/off the menu.

2 JOG dial button

With the menu open, this button is used to navigate through menu pages, select options and specify values.

For directions on manipulating the menu, see [4-6 Menu Displays in the Viewfinder Screen].

3 SD memory card insertion slot

An SD memory card (optional accessory) is inserted here. This slot is used for writing/saving menu data.

4 BUSY (operation mode display) lamp

This lamp indicates the active status of the SD memory card.

It stays illuminated when the card is active.

<Note>

While the lamp is on, do not insert or remove the card.

2-6 Time Code Section

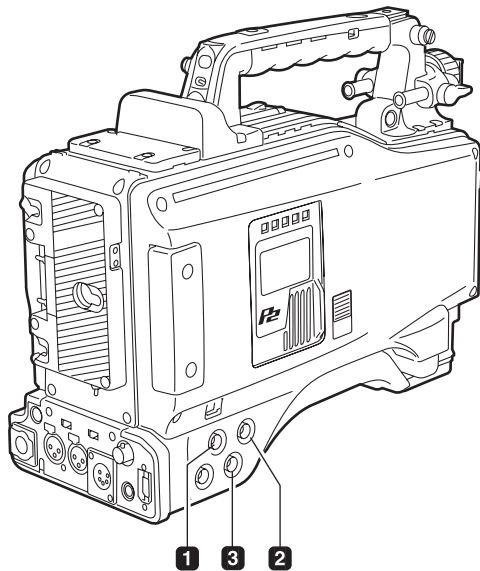

1 GENLOCK IN connector (BNC)

This connector is used to input a reference signal before the camera unit is gen-locked, or before the time code is externally locked.

2 TC IN connector (BNC)

This connector is used to input a reference time code when you externally lock the time code.

3 TC OUT connector (BNC)

When you inter-lock the time code of the AJ-SPX900E with that of an external device this must be connected with the time code input (TC IN) connector of the external device.

4 HOLD button

Pressing this button freezes the time data indication on the counter. Note that time code generation continues. Pressing the button again reactivates the counter. This function is used to ascertain the time code or CTL count of a particular recorded scene.

5 RESET button

This button resets the time data (CTL) on the counter to "00:00:00:00".

If this button is pressed when with the 7 TCG switch positioned at [SET], time code and user's bit data are reset to 0, and real-time data is reset to the initial value.

6 DISPLAY (counter display selector) switch

Indications of the time code, CTL and user bits on the counter of the display window depend on the positions of this switch and the 7 TCG switch.

Pressing the 4 HOLD button also displays Date/Time/Time Zone.

UB: User bits indicated.

TC: Time code indicated.

CTL: CTL indicated.

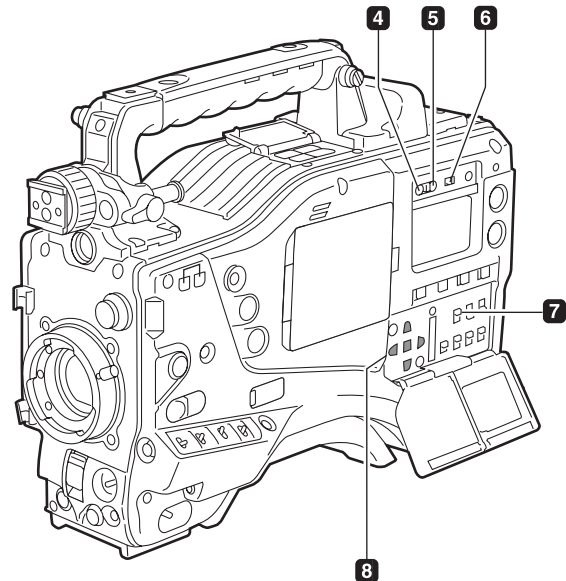

7 TCG (time code selector) switch

This switch is used to specify the stepping mode for the built-in time code generator.

F-RUN: Select this position to continuously advance the time code independently of the P2 card recording status.

Use this mode to synchronise the time code with the time of day, or to externally lock the time code.

SET: Select this position to set the time code and/or user bits.

R-RUN: Select this position to advance the time code only during recording.

For spliced scenes recorded on P2 cards, the sequence of time codes is unbroken.

8 CURSOR and SET buttons

Use these buttons to set the time code and user bits.

The four triangular buttons are the CURSOR buttons, and the center rectangular one is the SET button.

For guidance in setting the time code and user's bit, see [4-5 Setting Time Data].

2-7 Warning and Status Display Functions

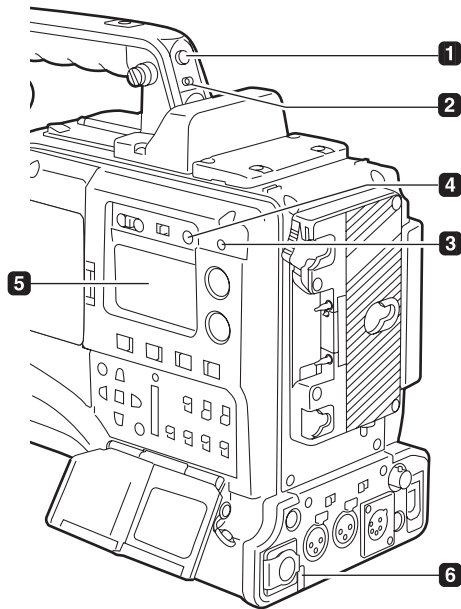

1 Back tally lamp

When the **2** BACK TALLY switch is set to [ON], the lamp behaves in the same way as the front tally lamp at the viewfinder.

2 BACK TALLY switch

This switch controls the action of the **1** back and **6** rear tally lamps.

ON: Back and rear tally lamps enabled.
OFF: Back and rear tally lamps disabled.

3 WARNING lamp

This lamp starts blinking or lights up if something unusual occurs in the memory.

4 LIGHT button

Use this button to control illumination of the display window. Alternately pressing this button toggles illumination of the **5** display window on or off.

5 Display window

This window displays warnings, battery-remaining level, sound volume, time data, and other information.

6 Rear tally lamp

When the **2** BACK TALLY switch is set on [ON], the rear tally lamp behaves in the same way as the back tally lamp.

2-8 Display Window Functions

P2 card/battery-remaining level indications

Media-remaining space indication bar

The bar indicates the remaining free space on each P2 card, using a seven-segment display.

Each segment can represent either three or five minutes of remaining free space, depending on the value set through the menu option CARD REMAIN/■. According to the set value, the segments disappear one-by-one. The menu option CARD REMAIN / ■ can be found in the <BATTERY/P2CARD> screen on the MAIN OPERATION page.

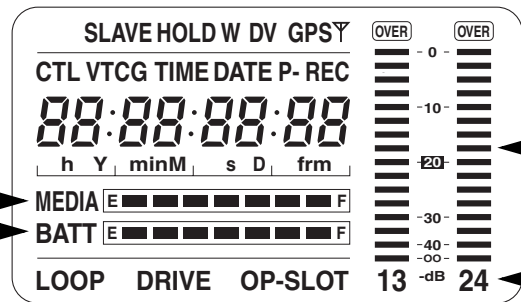

Battery-remaining level indication bar

For a battery with a digital indicator (percentage indication), if the remaining level of the battery is higher than 70%, all seven segments up to the "F" position are lighted.

When the remaining level falls below 70%, the segments go out one-by-one for each drop of 10%. All seven segments can be set to light up when the battery-remaining balance is 100%. To do so select "100%" for the menu option BATT REMAIN FULL in the <BATTERY/P2CARD> screen of the MAIN OPERATION page.

Audio channel level meter

When the MONITOR SELECT CH1/2 / CH3/4 switch is set to [CH1/2], the meter indicates 1 and 2 as the audio channel numbers, together with their audio levels. When the switch is set to [CH3/4], the meter indicates 3 and 4 as the audio channel numbers, together with their audio levels.

Memory action status indication

Error Code Indication (for more information, see [7-3 Warning System])

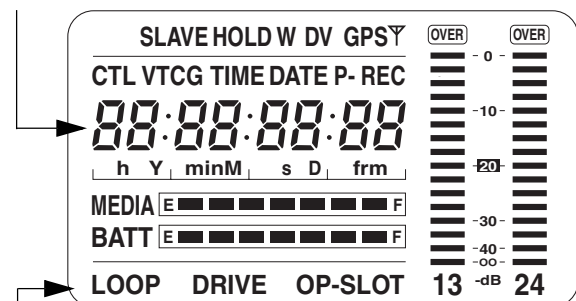

Information indication

LOOP: Stays illuminated in LOOP REC mode. For information about the LOOP REC mode, see [3-5 Loop Recording].

DRIVE: Stays illuminated when the menu option USB is set to "ON". The menu option USB can be found in the <SYSTEM MODE> screen on the SYSTEM SETTING page.

OP-SLOT: Remains illuminated when a video encoder card is operated in the optional slot.

2-9 LCD Monitor

2

Mode indication

W: Stays illuminated in 16:9 mode.

DV: Stays illuminated when the recording/playback format is DV.

GPS: Stays illuminated when radio waves are not received during GPS operation.

GPS Υ : Stays illuminated when radio waves are received during GPS operation.

P-REC: Stays illuminated when PRE RECORDING is not set to 0 seconds, and blinks when recording is continued after the recording tally lamp has gone out.

iREC: Remains illuminated during INTERVAL REC mode recording, and blinks during a pause.

i: Blinks when INTERVAL REC mode is selected.



Time code indication

SLAVE: Stays illuminated when the time code is externally locked.

HOLD: Stays illuminated when the time code generator/reader value is frozen.

CTL: Stays illuminated when the DISPLAY switch is positioned at [CTL] to display the CTL count.

TCG: Stays illuminated when the DISPLAY switch is positioned at [TC] (or [UB]) to display the TC (or UB) generator value.

TC: Stays illuminated when the DISPLAY switch is positioned at [TC] (or [UB]) to display the TC (or UB) reader value.

VTCG: Stays illuminated when the DISPLAY switch is positioned at [UB] to display the VIUB generator value.

VTC: Stays illuminated when the DISPLAY switch is positioned at [UB] to display the VIUB reader value.

TIME: Stays illuminated when the DISPLAY switch is positioned at [UB] to display the real-time hour, minute and second.

DATE: Stays illuminated when the DISPLAY switch is positioned at [UB] to display the real-time date.

No Indication:
The CTL, VTCG, TIME, and DATE stay off when the DISPLAY switch is positioned at [UB] to display real time, time zone, hour and minute.

Time count indication:
The time code, CTL, user bits and real time are shown.

<Note>
When the DISPLAY switch is positioned at UB, each press of the HOLD button changes the indication through VTCG (VTC) → DATE → TIME → No Indication (Time Zone) → TCG (TC), in that order.

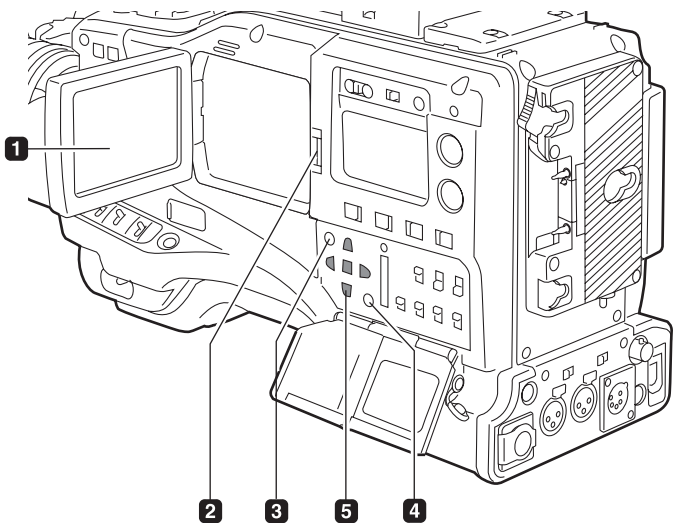

- 1 LCD monitor**
The LCD monitor displays the video in the viewfinder. Alternatively, it can show clips on the P2 card in a thumbnail format. In thumbnail display mode, clips can be edited or deleted, or P2 cards can be formatted using the **4** MENU BAR button and **5** CURSOR and SET buttons.
- 2 OPEN button**
Used to open the LCD monitor.
- 3 THUMBNAIL button**
This button switches the content on the **1** LCD monitor from the video in the viewfinder to clip thumbnails. Another press switches them back to the video from the viewfinder. Note that this switchover is not performed during a recording or playback.
- 4 MENU BAR button**
In thumbnail display mode, this button allows you to manipulate the menu bar (e.g., to delete clips).
- 5 CURSOR and SET buttons**
The four triangular buttons are the CURSOR buttons, and the center rectangular one is the SET button. They are used to select a thumbnail and manipulate the menu bar. For more information, see [Chapter 6 Manipulating Clips with Thumbnails].

Positions of time code-related switches and information provided

Position of DISPLAY switch	Position of TCG switch	Information Item
CTL	SET	Time code
	F-RUN or R-RUN	CTL
TC	F-RUN/SET/ R-RUN	Time code
UB		User's bit or real-time, time zone

2-10 Viewfinder

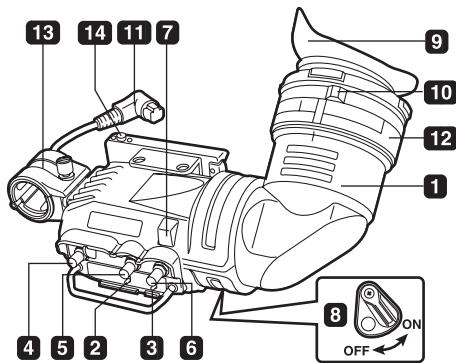

1 Viewfinder (optional accessory)

During recording or playback, the viewfinder displays the video image in monochrome. It also displays warnings, messages, zebra patterns, markers (safety zone and center markers), etc.

2 ZEBRA (zebra pattern) switch

This switch is used to display the zebra pattern in the viewfinder.

ON: Zebra pattern displayed.

OFF: No zebra pattern displayed.

3 TALLY switch

Used to control the 7 front tally lamp.

HIGH: Front tally lamp brightly illuminated.

OFF: Front tally lamp stays off.

LOW: Front tally lamp dimly illuminated.

4 PEAKING control

Used to adjust the outlines of the video image in the viewfinder for easier focusing. This does not affect the signal output from the camera.

5 CONTRAST control

Used to adjust the contrast of the video image in the viewfinder. This does not affect the signal output from the camera.

6 BRIGHT control

Used to adjust the brightness of the video image in the viewfinder. This does not affect the signal output from the camera.

7 Front tally lamp

This lamp is activated when the 3 TALLY switch is positioned at [HIGH] or [LOW], and stays on during recording. It also blinks in synchronisation with the REC lamp in the viewfinder, and provides alerts.

Use the TALLY switch to change the intensity of the lamp to ([HIGH] or [LOW]).

8 Back tally lamp

This lamp stays illuminated during shooting. It also blinks in synchronisation with the REC lamp in the viewfinder, and provides alerts.

When the lever is positioned at [OFF], the back tally lamp is hidden.

9 Eyepiece

10 Diopter adjustment ring

Use this to make adjustments in line with your diopter, in order to obtain optimum clarity in the viewfinder image.

11 Connecting plug

12 Locking ring

13 Microphone holder

14 Viewfinder stopper

Used to attach or remove the viewfinder.

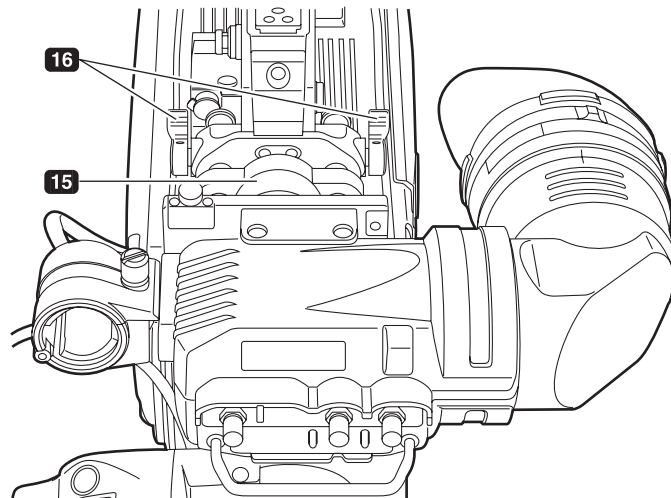

15 Viewfinder left-right position anchoring ring

Used to adjust the side-to-side position of the viewfinder.

16 Viewfinder front-back position anchoring lever

Used to adjust the fore-and-aft position of the viewfinder.

<Note>

For more information, see the instruction manual for the viewfinder.

Chapter 3 Recording and Playback

3-1 P2 Cards

Inserting P2 Cards

<Note>

When using the camera-recorder for the first time, be sure to set the time data beforehand. On how the time data is set, see [4-5 Setting Time Data].

- 1 Turn on the POWER switch.

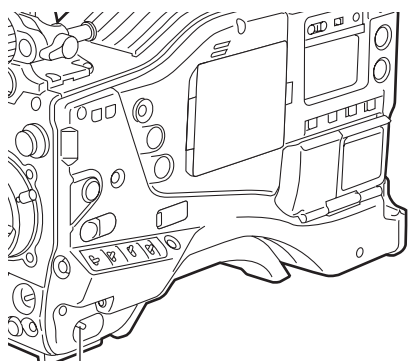

POWER: ON

- 2 While pressing down the slide lock button, slide the slide-out door to the left. The door opens.

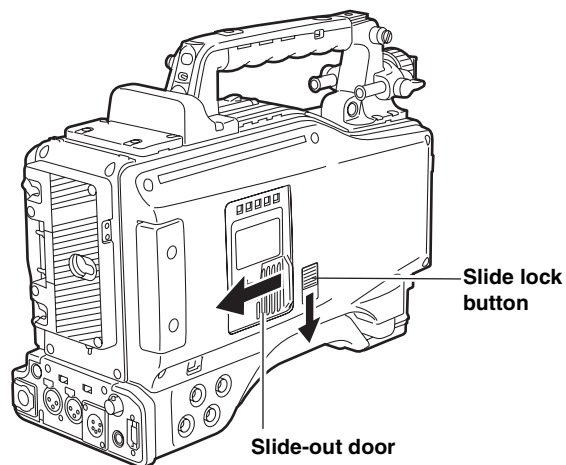

Slide lock button

Slide-out door

- 3 Insert a P2 card into the P2 card slot until the EJECT button pops up.

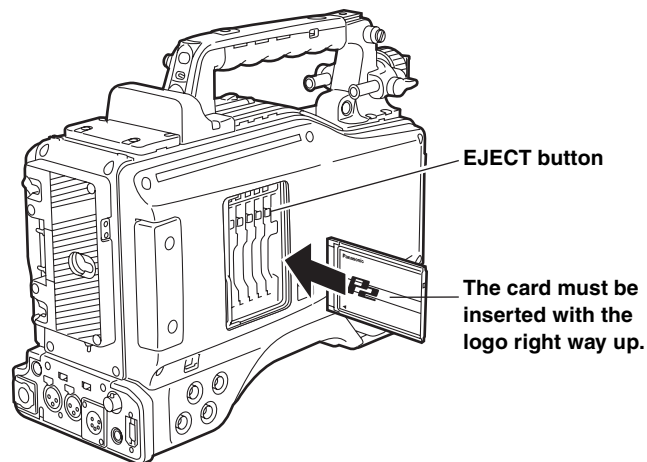

EJECT button

The card must be inserted with the logo right way up.

- 4 Tilt up the popped-up EJECT button, to lock-in the P2 card.

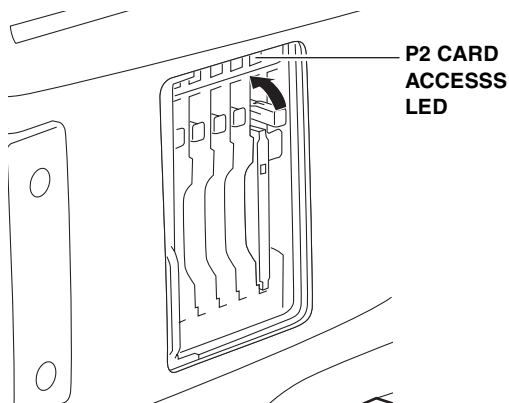

P2 CARD ACCESS LED

- 5 Insert a P2 card into the AJ-SPX900E. The P2 CARD ACCESS LED for the appropriate slot indicates the status of the P2 card. For how the P2 card status is indicated, see [P2 CARD ACCESS LED and status of P2 cards] (page 24).
- 6 Close the slide-out door.

<Note>

Do not leave the slide-out door open when moving the AJ-SPX900E.

Removing P2 Cards

- 1 While pressing down the slide lock button, move the slide-out door to the left. The door opens.
- 2 Tilt down the EJECT button.
- 3 Then, depress the EJECT button to release the P2 card so that you can remove it.

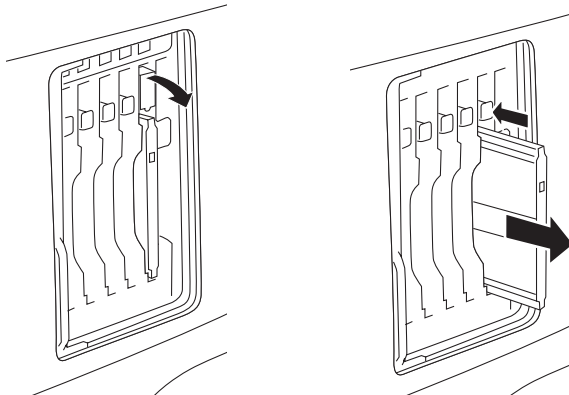

Tilt down the EJECT button.

Depress the tilted-down EJECT button to release the P2 card.

<Notes>

- When a P2 card is being accessed or it is being recognised after insertion (P2 CARD ACCESS LED blinks in orange), do not remove the P2 card. If your AJ-SPX900E is not set to turn on the P2 CARD ACCESS LED, before removing the card ensure that pre-recording and/or voice memo recording have finished (the P-REC indication has stopped blinking and the V mark or VOICE REC indication on the viewfinder screen has turned off) after stopping recording or playback.
- If a P2 card being accessed is removed, the viewfinder displays "TURN POWER OFF" and the AJ-SPX900E gives a warning using an alarm and the WARNING LED. In addition, all P2 CARD ACCESS LEDs blink rapidly in green. If this is the case, turn the power off. For more information on warning indications, see [7-3 Warning System].
- If a P2 card is removed while being accessed, clips on it may become irregular although the data will not be corrupted. Check the clips and restore them if required. For more information about how to restore clips, see [6-9 Restoring Clips].
- If a P2 card being formatted is removed, it may be not be formatted properly. In this case, the viewfinder displays "TURN POWER OFF". If this message appears, turn off the power, then restart the AJ-SPX900E to reformat the card.
- If a P2 card is inserted while another P2 card is being played back, the inserted P2 card is not recognised and the P2 CARD ACCESS LED for that card does not come on. Card recognition starts when the playback ends.

<For Your Information>

The P2 CARD ACCESS LEDs may be set to stay off using the menu option ACCESS LED. This option can be found on the <SYSTEM MODE> screen, which is accessible from the SYSTEM SETTING page.

To Prevent Accidental Erasure of P2 Card Content

To prevent the content of a P2 card being accidentally erased, position the write-protect switch on the P2 card at [Protect].

<Note>

Write-protect switchover can be performed while the card is being accessed (during recording or playback), but does not take effect until access to the card ceases.

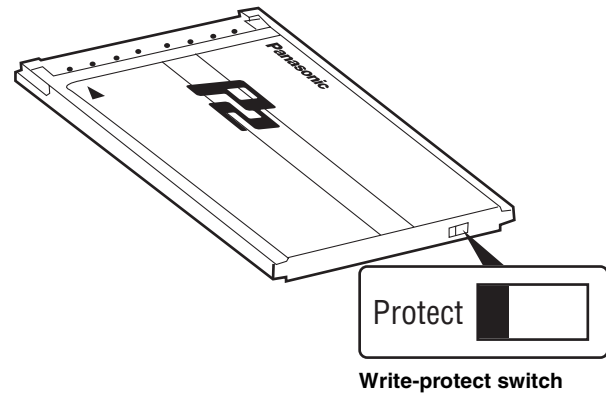

Write-protect switch

P2 CARD ACCESS LED and status of P2 cards

P2 CARD ACCESS LED	MODE CHECK indication*	Status of P2 Card
Stays on in green	ACTIVE	Writing and reading enabled
Stays on in orange	ACTIVE	Writing and reading enabled. The card is recordable (loop recording also enabled).
Stays on in orange or green	ACTIVE !	Writing and reading enabled. However, some clips recorded on the P2 card may not be able to be read successfully.
Blinks in orange	ACCESSING	Writing or reading being performed.
Quickly blinks in green	INFO READING	The P2 card is being recognised.
Blinks in green	FULL	The P2 card has no free space. Only reading is enabled.
	PROTECTED	The write-protect switch on the P2 card is positioned at [PROTECT]. Only reading is enabled.
Stays off	NOT SUPPORTED	The card is not supported by your AJ-SPX900E. Replace the card.
	FORMAT ERROR	The P2 card is not properly formatted. Reformat the card.
	NO CARD	No P2 card is inserted.

* The mode check indication is shown in the viewfinder. For more information, see [4-7-2 Viewfinder Status Indication Layout].

3-2 Basic Procedures

This section describes the basic procedure for shooting and recording.

Before you embark on a shoot, pre-inspect your system to ensure that it works properly.

* For directions on inspecting your memory card camera-recorder, see [7-1 Inspections Before Shooting].

Battery Set-up to P2 card Insertion

- 1 Insert a charged battery pack.
- 2 Turn on the POWER switch and ensure that more than four segments of the battery-remaining amount indication bar are illuminated.
 - If the number of illuminated segments is fewer than five, first check the battery placement. If placement is not the problem, replace the battery with a fully charged one.
- 3 Insert a P2 card and ensure that the P2 CARD ACCESS LED stays on in orange or green. Then, close the slide-out door.

When more than one P2 card slot contains a P2 card, the card in the slot with the lowest number is used first. However, regardless of slot number, a P2 card inserted later will not be accessed until the other cards have been used.

Example:

If all five slots contain P2 cards, the cards are used in order of slot numbers 1→2→3→4→5. However, if the P2 card in Slot 1 is removed and then re-inserted, the cards will be used in the following order: 2→3→4→5→1.

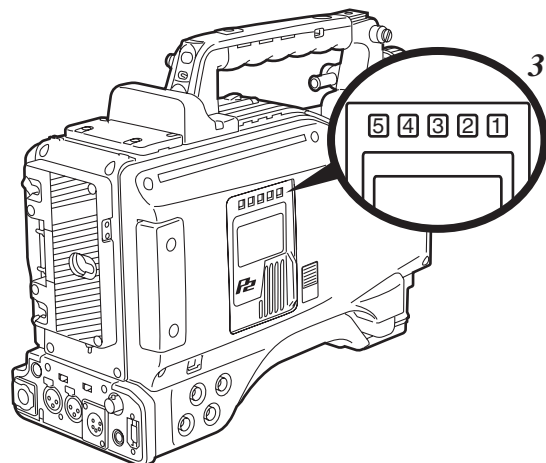
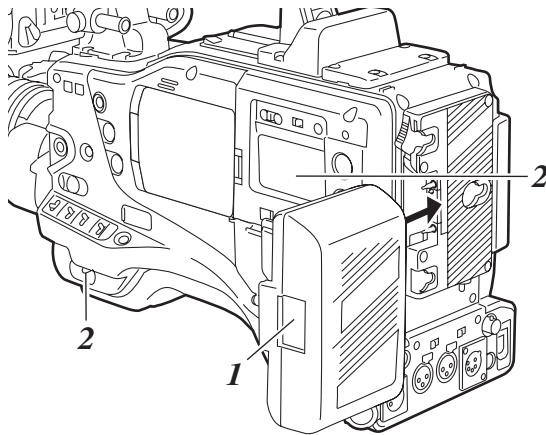

Note that the recording order is retained even if the power is turned off. When the power is next turned on, the last card written before powering-down will be the target card.

<Note>

When "SLOT1" is selected for the menu option P.ON REC SLOT SEL, recording starts from the P2 card inserted in the smallest slot number, after the power is turned on.

This option is found in the REC FUNCTION screen on the SYSTEM SETTING page.

Switch Setting

When a battery and P2 cards are installed, set the switches as detailed below, before starting to use your AJ-SPX900E.

Setting the switches before shooting and recording

USER MAIN:

This switch is factory-set to perform slot selection.

AUDIO SELECT

CH 1/CH 2:
AUTO

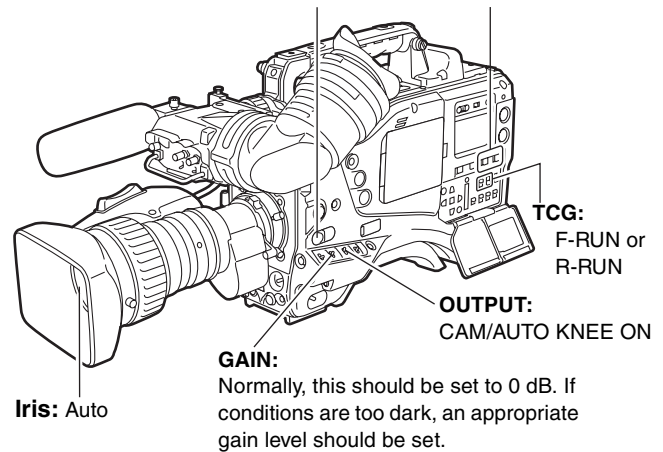

<Note>

The USER MAIN button is factory-set to perform the slot selection function, which selects the target card from among several P2 cards.

When a new target P2 card is selected, the appropriate slot number appears on the P2 card remaining amount indicator in the viewfinder.

For more information about the indications in the viewfinder, see [4-7-2 Viewfinder Status Indication Layout].

Shooting

White/Black Balance Adjustment to Recording Completion

For shooting, follow the steps below.

1 Select a filter according to light conditions.

2A **When the white balance is saved:**
Position the WHITE BAL switch to [A] or [B].

2B **When the white or black balance is not saved and you have no time to adjust the white balance:**
Position the WHITE BAL switch to [PRST].
This adjusts the white balance against the filter according to the position of the FILTER control.

2C **If the white balance is adjusted on the spot:**
Select a filter according to light conditions. Then, position the WHITE BAL switch to [A] or [B] and shoot a white test subject so that it appears at the center of the screen. Then, follow the steps below to adjust the white balance.

1. Press the AUTO W/B BAL switch toward [AWB] to adjust the white balance.
2. Press the AUTO W/B BAL switch toward [ABB] to adjust the black balance.
3. Press the AUTO W/B BAL switch toward [AWB] to adjust the white balance again.

For directions on making adjustments, see [4-1-1 Adjusting the White Balance] and [4-1-2 Adjusting the Black Balance].

3 Point the camera at your subject to adjust the focus, and zoom.

4 To use the electronic shutter, set the shutter speed and operation mode.
For more information, see [4-2 Setting the Electronic Shutter].

5 Press either the REC START/STOP button, REC button on the handle or VTR button at the lens to start recording.
During recording, the REC lamp in the viewfinder stays illuminated.

6 To stop recording, press either the REC START/STOP button, REC button on the handle or VTR button at the lens.
The REC lamp in the viewfinder goes out.

White/Black balance adjustment to recording completion

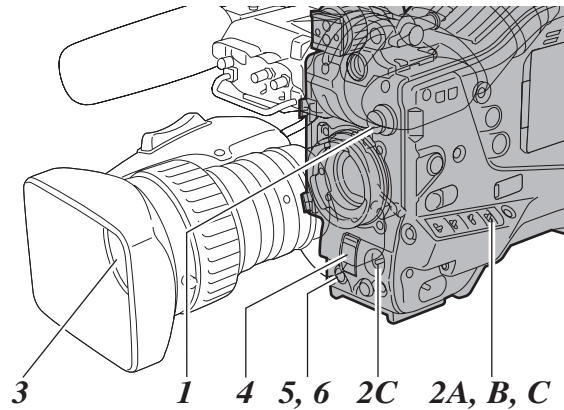

Operation Buttons

During recording, all operation buttons (REW, FF, PLAY/PAUSE, STOP) are disabled.

3-3 Normal Recording

Pressing either the REC START/STOP button, REC button on the handle or VTR button at the lens starts recording of video and sound on the P2 card.

A cluster of data that consists of video and sound generated through a shooting action, together with such added information as a voice memo, is called a "clip".

<Note>

Even if a P2 card has just been inserted, or the power has been just turned on, you can start recording using the internal memory of the AJ-SPX900E. In this case, recording cannot be stopped until the P2 card is recognised.

If the inserted card is not recognized as a recordable P2 card, the record in internal memory is instantly discarded, and the message "CANNOT REC" message is displayed on the viewfinder.

Press the MODE CHECK button to check P2 card status (displayed in viewfinder).

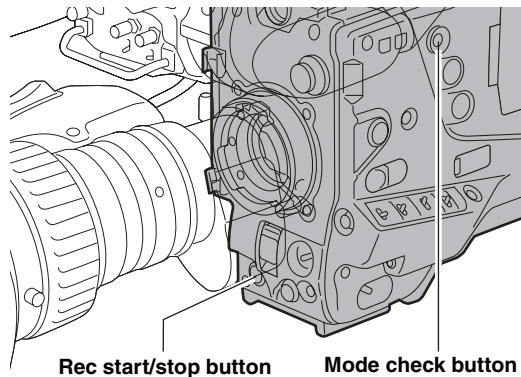

3-4 PRE-RECORDING function

The internal memory of your AJ-SPX900E is capable of storing several seconds of video and sound data coming from the camera. This capability can be used to record video and sound several seconds before either the REC START/STOP button, REC button on the handle or VTR button at the lens is pressed to start recording.

To use this capability, the storage duration of the internal memory must be set through the menu option PRE REC TIME. This option can be found in the <REC FUNCTION> screen on the SYSTEM SETTING page.

These are the options for PRE REC TIME.

0-15 SEC (for DVCPRO 25M or DV)

0-8 SEC (for DVCPRO 50M):

Specify the duration for which data may be recorded before either the REC START/STOP button, REC button on the handle or VTR button at the lens is pressed.

<Notes>

- Immediately after the power is turned on, the menu option PRE REC TIME is selected and/or the storage duration is changed, the content in internal memory will be undefined. In these situations, the video or sound will not be recorded for the duration specified, even if either the REC START/STOP button, REC button on the handle or VTR button at the lens is pressed to start recording.
- A P2 card that has been just inserted takes some time to recognise. In this situation, video or sound may not be recorded for the duration specified, even if either the REC START/STOP button, REC button on the handle, or VTR button at the lens is pressed to start a recording.
- The internal memory does not store video or sound when a playback or recording review is being performed. For this reason, no video or sound can be recorded during such operation.
- When recording starts, the time code indication (TCG) may be shown as "HOLD" until the P2 card has been recognised.
- During recording of IEEE1394 input or INTERVAL REC operation, PRE RECORDING is not available.

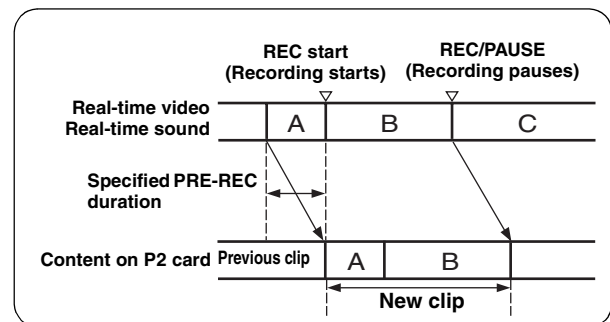

3-5 Loop Recording

When two or more P2 card slots contain cards, this function allows the target P2 card to be switched in order. Even when the free space of a P2 card is used up, this function continues recording while erasing existing data.

To use this function, the menu option LOOP REC MODE must be set to "ON". The option LOOP REC MODE can be found in the <REC FUNCTION> screen on the SYSTEM SETTING page.

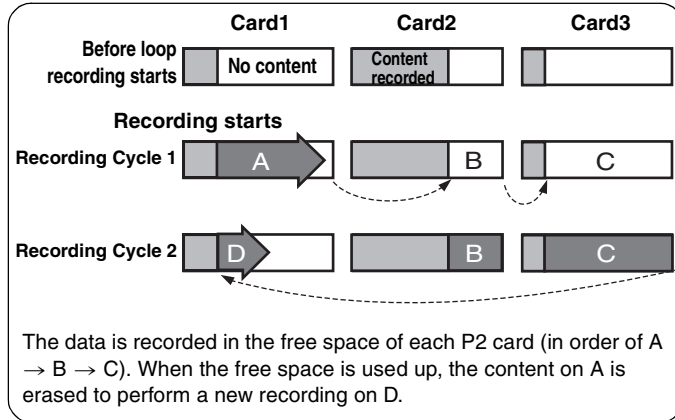

<Note>

- When the loop recording capability is used, each P2 card must have at least one minute of free space.
- During loop recording, the P2 CARD ACCESS LEDs for all target P2 cards illuminate in orange. Note that if any of the target P2 card is removed, loop recording stops.
- When the menu option LOOP REC MODE is set to ON, the viewfinder and display window both show "LOOP". However, when only one card is inserted, or when each card has less than one minute of free space, the loop recording capability does not work, even if the option LOOP REC MODE is set to ON. If this is the case, the indication "LOOP" flashes in the viewfinder and on the display window.
- During recording of IEEE1394 input or INTERVAL REC operation, LOOP REC is not available.

Terminating the Loop Recording Mode

You can terminate the loop recording mode by either:

- Turning off the POWER switch of the AJ-SPX900E; or
- Setting the menu option LOOP REC MODE to "OFF".

3-6 INTERVAL REC

Using the internal memory of the AJ-SPX900E, interval recording is available for a minimum 1-frame unit (50i, 25P mode).

To use this option, open the REC FUNCTION screen from the SYSTEM SETTING page, and set the interval recording mode, REC TIME, PAUSE TIME and TAKE TOTAL TIME for the menu option INTERVAL REC MODE. When the settings are finalized, TOTAL REC TIME needed on the P2 card is automatically calculated and displayed.

The following are the options for INTERVAL REC MODE:

OFF:

No interval recording performed.

ON:

Interval recording performed.

ONE SHOT:

Performs "one-shot" recording for the duration specified under the REC TIME option by pressing either the REC START/STOP button, REC button on the handle, or VTR button at the lens.

Shooting procedures when INTERVAL REC is ON

- 1 Following basic operations of shooting and recording according to [3-2 Basic Procedures], lock the camera securely.
- 2 Check that "i" is blinking in the display, and that the interval recording mode is selected.
- 3 Press either REC START/STOP button, REC button on the handle, or VTR button at the lens.
Interval recording starts. Recording automatically stops after the specified TAKE TOTAL TIME, and the entire recording is generated as one clip.
"i" starts blinking in the display when the interval recording mode is selected. "iREC" illuminates after recording starts. "iREC" blinks during a pause.
The display in the viewfinder is the same as that in the display window.
The tally lamp illuminates during recording. If PAUSE TIME is set at 2 minutes or longer, the tally lamp illuminates at 5-second intervals to indicate that it is paused. The tally lamp also blinks 3 seconds before recording starts.

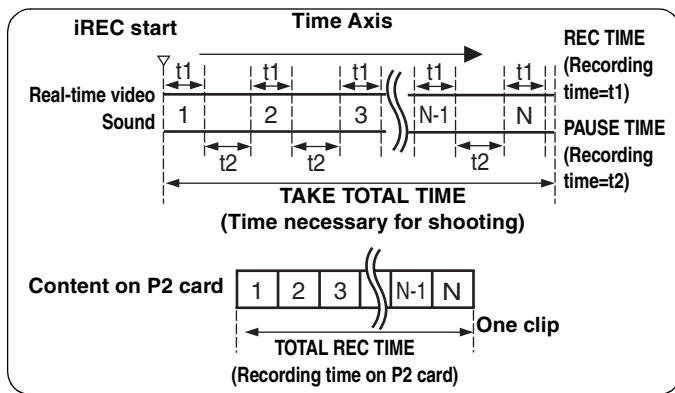

For continuous recording

Press either the REC START/STOP button, REC button on the handle, or VTR button at the lens, again. Interval recording resumes.

To stop recording

Press the STOP button. Recording stops. Then, the camera accesses the P2 card to record the video stored in memory before recording stops. The record from the beginning of the interval recording to the moment of pressing the STOP button is generated as one clip.

To stop the Interval recording mode

Interval recording mode can be terminated by either:

- Turning off the POWER switch of the AJ-SPX900E
or
- Setting the menu option INTERVAL REC MODE to "OFF".

Shooting procedures for the ONE SHOT mode of INTERVAL REC

After setting the INTERVAL REC mode, follow these steps:

- 1 Following basic operations of shooting and recording according to [3-2 Basic Procedures], lock the camera securely.
- 2 Press either the REC START/STOP button, REC button on the handle, or VTR button at the lens.
The AJ-SPX900E automatically goes into ONE SHOT pause mode after the specified REC TIME.
- 3 Performs recording for the duration specified under the REC TIME option by pressing either the REC START/STOP button, REC button on the handle, or VTR button at the lens, and returns to ONE SHOT pause mode.
- 4 Press the STOP button.
The video and sound stored in memory are generated as one clip.

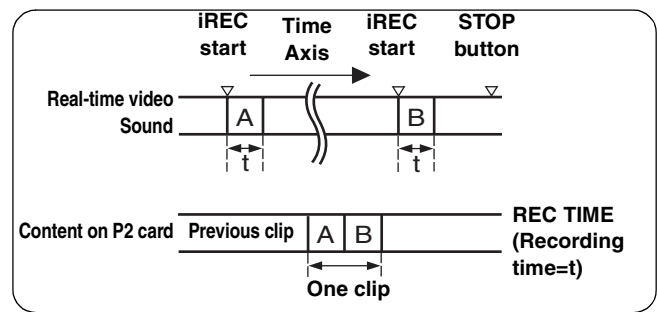

To check the previous recording during a pause

Press the RET button at the lens to put the AJ-SPX900E into REC REVIEW mode. ONE SHOT operation continues after the REC REVIEW.

To divide clips or to change the P2 card used for recording

Even during ONE SHOT mode, clips will not be generated on the P2 card until the STOP button is pressed. Press the STOP button, and stop ONE SHOT mode operation.

To stop the ONE SHOT mode of INTERVAL REC

The ONE SHOT mode can be terminated by either:

- Turn off the POWER switch of the AJ-SPX900E
or
- Set the menu option INTERVAL REC MODE to "OFF".

During INTERVAL REC mode general notes

● Sound

By selecting ON/OFF for the menu option AUDIO REC in the REC FUNCTION screen, it is possible to specify whether or not sound will be recorded during interval recording.

● Record/Playback Buttons

During interval recording, all operation buttons other than STOP (REW, FF, PLAY/PAUSE) are disabled. However, during a pause in ONE SHOT mode, the RET button at the lens is enabled.

● If the power is turned off during recording

If the AJ-SPX900E is turned off during interval recording, the video stored in memory is recorded onto the P2 card, and then the camera automatically turns off.

● To start emergency recording during a pause

By setting the REC button to USER MAIN or USER1/USER2, emergency recording can be performed during a pause by pressing the button. Pause time measurement continues after such emergency recording.

● Time code indication

When recording starts, the time code indication (TCG) may be shown as "HOLD" until the P2 card has been recognized.

● Removing cards

During INTERVAL REC mode operation, the P2 card access LED for the inserted P2 card blinks in orange. Do not remove the P2 card during this status. If you should remove the card accidentally, restore clips. However, even after restoration, the last 2 seconds or so of the video may be lost. For more information on how to fix clips, see [6-9 Restoring Clips].

● Operation mode

INTERVAL REC does not work when "1394" is selected for the menu option REC SIGNAL. The menu option REC SIGNAL is found in the SYSTEM MODE screen on the SYSTEM SETTING page. For more information, see [3-11 Recording Setting and Operation Mode].

● Thumbnail operation and menu operation

Thumbnail operation does not work during the INTERVAL REC mode operation. Press the STOP button before operating thumbnails.

Menu operations are possible during standby status with the following restrictions.

- Read/write operation with an SD memory card is inoperable.
- A change of the menu setting related to the system and recording such as menu options CAMERA MODE, REC MODE, 25M REC CH SEL etc. may not always result in the recording as set. Stop the camera system by pressing STOP button before changing the setting.

3-7 Recording Review Function

When recording is paused, pressing the RET button automatically locates the last two seconds of video just recorded, and the viewfinder provides video playback.

After playback, the video camera-recorder is again ready to start recording.

The picture location/playback duration can be increased to up to 10 seconds by continuously pressing the RET button. For short clips, however, when the start of a clip is located, continuously pressing the RET button does not play back any clips before that clip.

The function of the RET button may be assigned to a desired user button by using one of the menu options USER MAIN SW, USER1 SW or USER2 SW. These options can be found in the <USER SW> screen on the CAM OPERATION page.

When recording is paused, pressing the PLAY/PAUSE button plays back the last recorded clip, from the beginning. After completion of playback, the camera-recorder enters the stopped state.

<Note>

When the OUTPUT SEL switch on the side panel is positioned at [MEM], the video for REC REVIEW is output from the video output connectors (VIDEO OUT and MON OUT connectors), and also to the viewfinder.

Note that when a backup device is connected to back up the video the pictures for REC REVIEW are backed up.

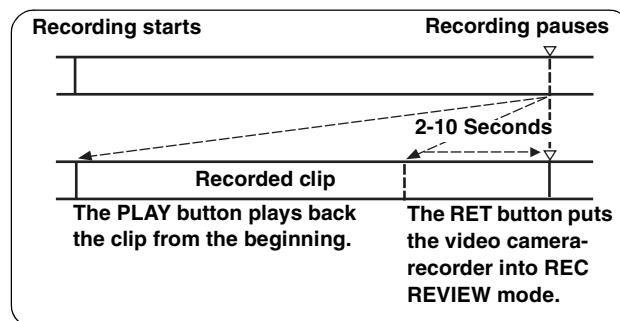

3-8 Normal and Variable Speed Playback

The PLAY/PAUSE button provides monochrome playback through the viewfinder and color playback on the LCD monitor. A color video monitor connected to the VIDEO OUT or MON OUT connector of the AJ-SPX900E also provides color playback.

When the extension board AJ-YA902AG is attached, the VIDEO OUT connector outputs an SDI playback (to view the playback, the OUTPUT SEL switch on the side panel must be positioned to [MEM]).

Variable speed playback

The FF and REW buttons provide 32× and 4× fast playbacks and fast reverse playbacks.

When playback is paused, the FF button locates the beginning of the next clip while maintaining the pause mode.

When playback is paused, the REW button locates the beginning of the current clip while maintaining the pause mode.

<Notes>

- When a P2 card has been just removed or inserted, or when the power has been just turned on for playback, it may take some time for the AJ-SPX900E to read clip information. If this is the case, the viewfinder displays "UPDATING".
- If a P2 card is inserted while another P2 card is being played back, the clips on the inserted P2 card will not be played back. A P2 card inserted during playback will be recognised after playback ends.
- If you perform variable speed playback on a clip split across more than one P2 card, sound may disappear for a moment. This is not a fault.

3-9 Voice Memo Function

A voice memo is voice data which can be added to a clip independently of the normal sound data recorded in the clip. Voice memos may be recorded during recording or playback, or when recording or playback is paused. They can be played back in thumbnail display mode.

<Note>

Each clip can accommodate up to 100 voice memos.

If the menu option VOICE MEMO RESERVE is set to "ON", you can record at least 10 minutes of voice memos for each P2 card while clip recording is paused or after recording ends.

Recording a Voice Memo

To add a voice memo to a clip during recording or playback, or when recording or playback is paused, press the VOICE MEMO button. A voice memo may be recorded using the voice memo microphone. Another press of the button stops recording of the voice memo.

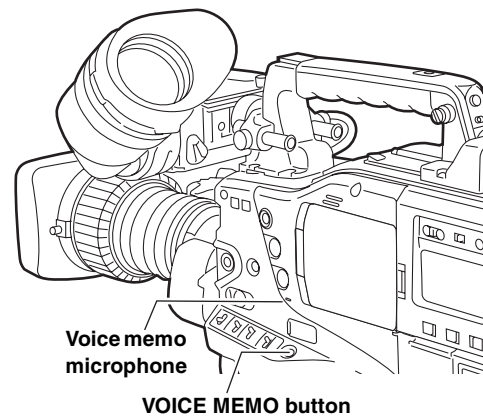

<Notes>

- Voice memos can also be recorded when the LCD monitor is in thumbnail mode. For more information, see [6-7-2 Recording a Voice Memo].
- Voice Memo is not available during output of color bars, video input via the GENLOCK IN connector, recording of 1394 input (optional), LOOP REC mode, or INTERVAL REC mode.
- During voice memo recording, turn down the speaker volume to prevent the voice memo microphone from picking up sound from the speakers of the AJ-SPX900E.
- When voice memo recording is performed during recording/playback of a clip, the voice memo recording also automatically ends when recording/playback of the clip ends. Also, when voice memo recording is performed during playback of a clip, playback of the clip also automatically ends when the voice memo recording is ended by pressing the VOICE MEMO button.

Associating Voice Memos with a Clip

The portion of the clip with which a voice memo is associated depends on when the voice memo is recorded.

A voice memo recorded during recording or playback is associated with the picture in view at the time the VOICE MEMO button is pressed. A voice memo recorded when recording is paused is associated with the beginning picture of the immediately preceding clip. A voice memo recorded when playback is paused is associated with the still picture in view at the time the VOICE MEMO button is pressed.

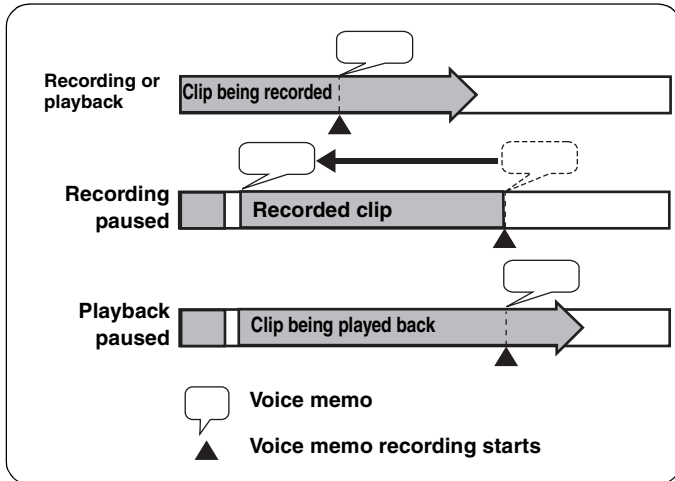

<Note>

When, with PRE RECORDING executed, a voice memo is recorded, the voice memo may be associated with a picture in view prior to point when the VOICE MEMO button is pressed.

Playing Back and Deleting Voice Memos

For information on how to play back and delete voice memos, see [6-7-1 Playing Back Voice Memos] and [6-7-3 Deleting Voice Memos].

3-10 Shot Mark Function

A shot mark is added to the thumbnail of a clip to distinguish that clip from others. With the LCD monitor, only clips that have shot marks can be viewed and/or played back.

Adding Shot Marks

To add a shot mark during recording, press the SHOT MARK button. The viewfinder displays "MARK ON" and adds a shot mark to the thumbnail of the appropriate clip. Another press of the button erases the shot mark.

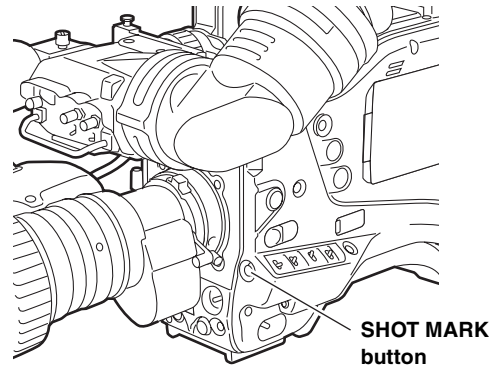

Shot marks may also be added or erased using clip thumbnails. For more information, see [6-6 Shot Mark].

<Note>

It is not possible to add or delete Shot Marks during output of color bars, video input via the GENLOCK IN connector, or recording of IEEE1394 input (optional).

3-11 Recording Setting and Operation Mode

The AJ-SPX900E recording mode works according to the priorities outlined in the following table, relative to the setting of the menus and switches.

Functional operation mode	Menu switches related to system/recording					Switches		Proxy recording (optional)
	USB	REC SIGNAL	INTERVAL REC MODE	LOOP REC MODE	PRE REC TIME	Recording a Voice Memo	Shot Mark	
USB drive	ON	Disabled	Disabled	Disabled	Disabled	Disabled	Disabled	Disabled
1394 Input record (optional)	OFF	1394 (optional)	Disabled	Disabled	Disabled 0 Fixed operation	Disabled	Disabled	Disabled
INTERVAL REC		CAMERA or VIDEO	ON or ONE SHOT	Disabled	Disabled 0 Fixed operation	Disabled	Enabled*1-2	Disabled
LOOP REC			OFF	ON	Enabled 0s - 8s/15s	Disabled	Enabled*1	Disabled
Normal Recording				OFF	Enabled 0s - 8s/15s	Enabled*1	Enabled*1	Enabled

*1 Enabled only during CAMERA recording (disabled for VIDEO IN recording or color bars)

*2 Shot Marks can be added to each clip. It is not possible to add to each cut.

Chapter 4 Adjustments and Settings for Recording

To record high-quality video with the AJ-SPX900E, the black and white balances must be adjusted according to conditions. For higher quality, it is recommended that the adjustments should be made in this order AWB (white balance adjustment) → ABB (black balance adjustment) → AWB (white balance adjustment).

4-1 Adjusting the White balance and Black Balance

4-1-1 Adjusting the White Balance

Whenever light conditions change, the white balance must be re-adjusted.

To adjust the white balance, follow the steps below.

1 Set the switches as illustrated below.

CC FILTER/ND FILTER controls

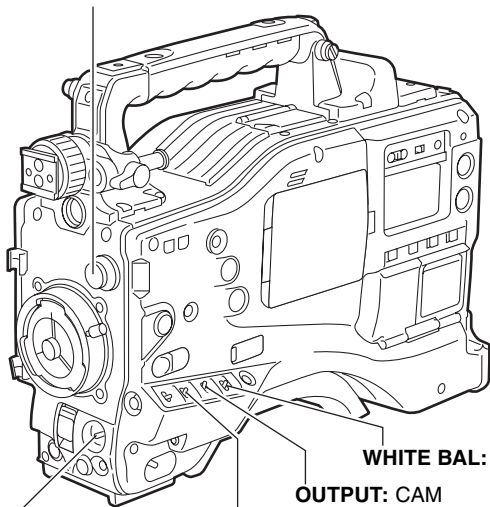

AUTO W/B BAL switch:
Used to perform AWB.

GAIN: Under normal conditions, set to 0 dB
If it is too dark, an appropriate gain should be set.

2 Adjust the CC FILTER/ND FILTER controls according to the light conditions.

<Note>

For examples of CC FILTER/ND FILTER adjustments, see [2-4 Shooting and Recording/Playback Functions Section].

3 Place a white pattern at a point where the light conditions match those for the light source of the subject. Then zoom-in on the white pattern so that white color appears in the screen. A white object (cloth or wall) may be used instead of a white pattern. The illustration below shows the required size for the white space.

<Note>

- Do not include a high-intensity spot in the screen.
- The white object must appear at the center of the screen.

1/4 or more of the screen in width

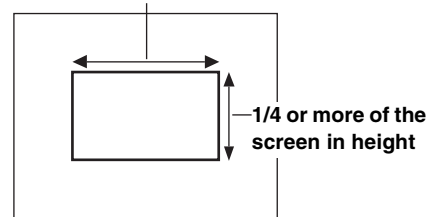

4 Adjust the lens iris.

5 Flip up the AUTO W/B BAL switch so that it is positioned at [AWB], then release it. The switch returns to the central position with the white balance automatically adjusted.

<Notes>

To cancel automatic white balance adjustment in process (the viewfinder displays "AWB ACTIVE"), re-position the AUTO W/B BAL switch at [AWB].

If automatic adjustment is canceled, the value in effect before automatic adjustment will be used.

6 During an adjustment, the viewfinder displays the following message:

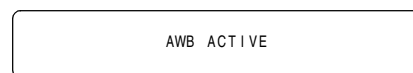

7 The adjustment will take effect in a few seconds, and the following message will appear: The adjusted value is automatically stored in the memory specified in Step 1 ([A] or [B]).

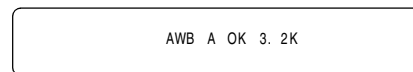

8 For the 3200K CC filter, if the subject's color temperature is lower than 2300K or higher than 9900K the following message appears:

If the arrow points down (↓) the actual color temperature is lower than the temperature indicated. If the arrow points up (↑) the actual temperature is higher than the temperature indicated.

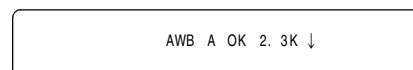

Detection area for the white balance

The detection area for the white balance is selectable between 90%, 50% and 25%, using the menu option AWB AREA. This option can be found in the <WHITE BALANCE MODE> screen, which is accessible from the CAM OPERATION page. The detection area is factory-set to 25%.

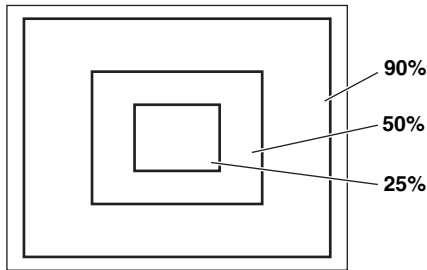

When you have no time to adjust the white balance:

Position the WHITE BAL switch at [PRST]. This adjusts the white balance for the filter according to the position of the FILTER control (outer).

When the white balance has not been automatically adjusted:

When the white balance has not been successfully adjusted, the viewfinder displays an error message. If one of the error messages listed below appears, take the appropriate steps, then adjust the white balance again. If the error message appears after repeated readjustments, the interior of the unit must be inspected. For more information, contact a service center or your distributor.

Error message	Description	Remedies
COLOR TEMP. HIGH	The color temperature is too high.	Select an appropriate filter.
COLOR TEMP. LOW	The color temperature is too low.	Select an appropriate filter.
LOW LIGHT	There is insufficient light.	Increase the light level or gain.
LEVEL OVER	There is too much light.	Decrease the light level or gain.
CHECK FILTER	The FILTER control is displaced.	Check the FILTER control.
TIME OVER	AWB was not completed within the time allowed.	Shooting conditions may be unstable. If flicker occurs, press the shutter and readjust the AWB under stable conditions.

Retaining white balances

Each value in memory is retained even if the video camera-recorder is turned off; it will not be lost until the white balance is re-adjusted. White balances are stored in either of two systems: A or B.

When the menu option FILTER INH is set to "ON" (default), each system stores only one value. If this is the case, the values are not synchronised with the CC filter.

This option can be found in the <WHITE BALANCE MODE> screen, which is accessible from the CAM OPERATION page.

When the menu option FILTER INH is set to "OFF", the adjusted value for each CC filter can be automatically stored in the memory that corresponds to the position of the WHITE BAL switch (A or B). Your AJ-SPX900E has four built-in CC filters; it stores eight (4 × 2) adjusted values.

Note that, when the menu options AWB A and AWB B are set to "VAR", the color temperatures specified through COLOR TEMP A and COLOR TEMP B are used, meaning that the white balances cannot be adjusted with the AWB switch. The menu options are found in the <WHITE BALANCE MODE> screen, which is accessible from the CAM OPERATION page.

Setting the auto-tracking white balance (ATW)

The AJ-SPX900E has an auto-tracking white balance (ATW) feature that automatically tracks the white balance for pictures according to lighting conditions.

The ATW feature can be assigned to Position [B] of the WHITE BAL switch. To do so, the menu option AWB B must be set to "ATW". This option can be found in the <WHITE BALANCE MODE> screen, which is accessible from the CAM OPERATION page.

The ATW feature may be assigned to the USER MAIN, USER1, or USER2 button. For more information, see [4-9-4 Assigning Functions to USER MAIN, USER1 and USER2 Buttons].

To cancel the auto-tracking white balance:

Press the user button that has the ATW feature assigned, or change the position of the WHITE BAL switch. Note that, when the ATW feature is assigned to [B] of the WHITE BAL switch, the auto-tracking white balance cannot be canceled with a user button.

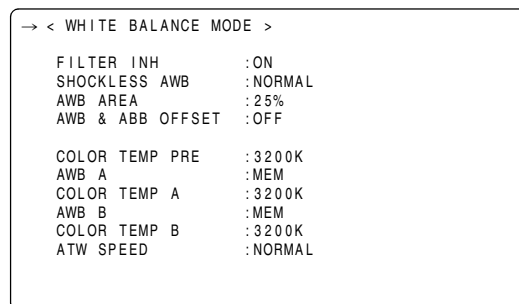

<Note>

This function does not guarantee 100% accuracy of the white balance.

When using the AJ-SPX900E, remember that there will be some allowance in the trackability of changes in lighting conditions and pull-in accuracy of white balances.

Viewfinder displays related to white balance

See [4-7 Viewfinder Screen Status Displays].

4-1-2 Adjusting the Black Balance

The black balance must be adjusted when:

- You use your AJ-SPX900E the first time;
- Your AJ-SPX900E has not been used for some time;
- The ambient temperature has changed substantially;
- The gain switchover value has been changed; or
- S.GAIN (super gain) has been set with the USER MAIN/USER1/USER2 button.

1 Set the switches as illustrated below.

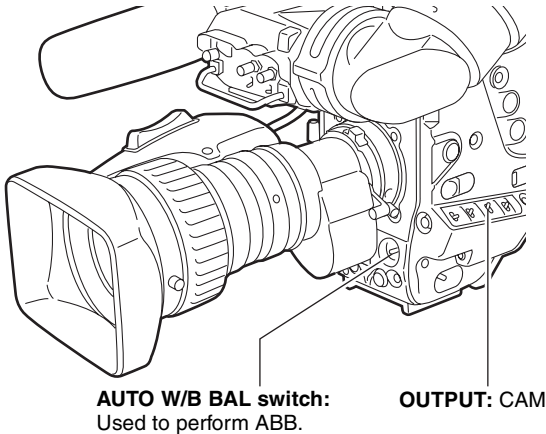

2 Tilt the AUTO W/B BAL switch so that it is positioned at [ABB], then release it. The switch returns to the central position with the black balance automatically adjusted.

3 During adjustment, the viewfinder displays the following message:



<Note>

During adjustment, the lens iris automatically becomes CLOSE.

4 The adjustment will take effect in a few seconds and the following message will appear:



The adjusted value is automatically stored in the memory.

<Notes>

- Ensure that the lens connector is connected and the lens iris is CLOSE.
- During a black balance adjustment, light is automatically cut off.
- During a black balance adjustment, the gain switchover circuit is automatically switched. The viewfinder screen may flicker and/or display noise; this is not a failure.
- If you find the black shading annoying after performing an auto black balance adjustment, adjust the black shading. To do so, go to the menu option DETECTION, move the cursor (→), then press the JOG dial button. The menu option DETECTION can be found in the <BLACK SHADING> screen, which is accessible from the MAINTENANCE page. Note that pressing the ABB switch for longer than five seconds automatically performs an auto black balance adjustment, followed by an automatic black shading adjustment. (For more information, see the menu option SHD. ABB SW CTL in [8-5-5 SW MODE].)
- To cancel the automatic black balance adjustment in process (the viewfinder displays "ABB ACTIVE"), flip the AUTO W/B BAL switch down to [ABB] again. If automatic adjustment is canceled, the value in effect before automatic adjustment will be used.

Retaining black balances

Each value in memory is retained even if the video camera-recorder is turned off.

4-2 Setting the Electronic Shutter

This section provides a description of the electronic shutter, together with setting and handling directions.

4-2-1 Shutter Modes

The table below shows the shutter modes and speeds for the electronic shutter provided in your AJ-SPX900E.

Mode	Shutter speed	Application
Normal	POSITIONS 1-6	Used to capture clear images of a fast-moving subject
SYNCHRO SCAN	Range of 50.4 Hz to 248.0 Hz (50i) Range of 25.0 Hz to 248.0 Hz (25P)	Used to reduce the effect of horizontal lines when shooting a monitor screen that has a vertical scanning frequency of more than 50 Hz
SUPER V		Used to enhance vertical resolution

<Notes>

- In any mode, the higher the shutter speed the lower the sensitivity of the camera.
- When the iris is automatically adjusted, the higher the shutter speed the larger the iris, and the shorter the depth of focus.

4-2-2 Setting the Shutter Mode and Speed

The shutter speed in any shutter mode is set using the SHUTTER switch.

In SYNCHRO SCAN mode, shutter speed can be switched easily, using the synchro-scan adjustment switches (+/-) on the side panel.

Note that the range of selectable shutter speeds may be pre-defined; whether or not to use the SYNCHRO SCAN and SUPER V modes may be determined through the <SHUTTER SPEED> and <SHUTTER SELECT> screens. These screens are accessible through the menu on the CAM OPERATION page.

The selected shutter speed is retained even if the AJ-SPX900E is turned off.

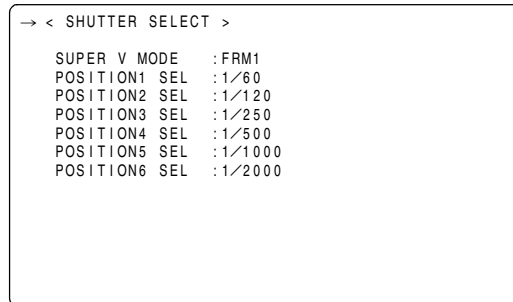
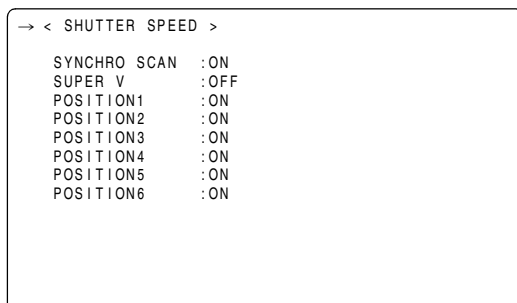

- 1 Press the SHUTTER switch, positioned at [ON], towards [SEL].

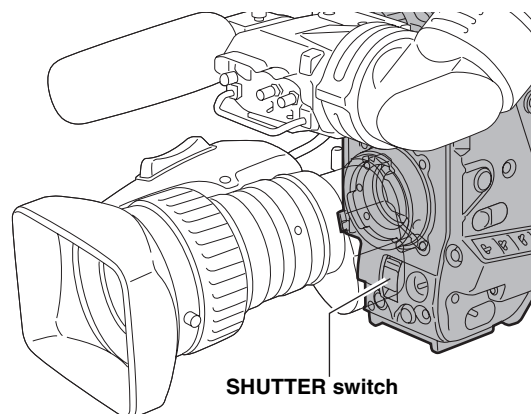

- 2 Once more, press the SHUTTER switch towards [SEL]. Repeat this switchover until the desired mode or speed appears in the viewfinder screen. If all modes and speeds are available, the display changes in the following order:

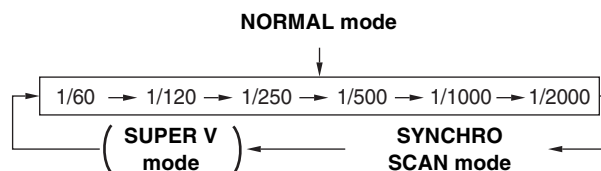

<Note>

Your AJ-SPX900E is not factory-set to display the SUPER V mode on the viewfinder screen. To display this mode, set the menu option SUPER V found in the <SHUTTER SPEED> screen, which is accessible from the CAM OPERATION page, to "ON".

Viewfinder displays relating to the shutter

See [4-7 Viewfinder Screen Status Displays].

4-2-3 Placing the Camera-recorder in SYNCHRO SCAN Mode

To place the camera-recorder in SYNCHRO SCAN mode, follow the steps below.

- 1 Press the SHUTTER switch positioned at [ON] towards [SEL], to place the camera-recorder in SYNCHRO SCAN mode.

SYNCHRO SCAN ADJUSTMENT buttons (+/-)

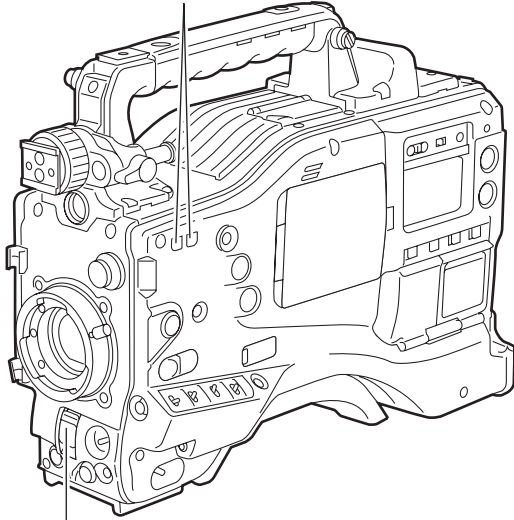

SHUTTER switch

- 2 In SYNCHRO SCAN mode, the speed can be switched seamlessly between 1/50.4 and 1/248.0 seconds, using the SYNCHRO SCAN ADJUSTMENT buttons (+/-). (Speed switchover is enabled in 50i mode.)

4-3 Selecting Recording Signals and Recording System

The AJ-SPX900E is capable of utilising user-selected recording signals and format.

4-3-1 Selecting the Recording Signals.

Signals to be recorded are selected through the menu options REC SIGNAL and CAMERA MODE. These options are found in the <SYSTEM MODE> screen, which is accessible from the SYSTEM SETTING page.

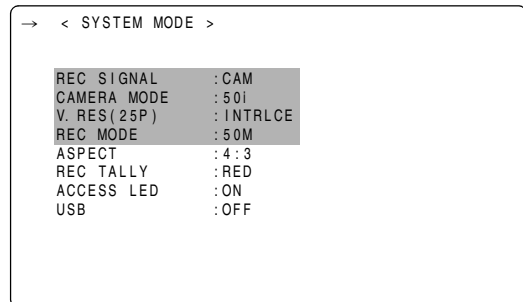

Setting options and usage

The option REC SIGNAL is used to select signals to be recorded.

CAM: Signals from the camera are recorded.

VIDEO: Signals from the GENLOCK IN connector are recorded.

1394: Signals from the DVCPRO/DV connector are recorded. (when the IEEE1394 interface board is attached).

The option CAMERA MODE is used to specify the operation mode of the camera. (effective when the menu option REC SIGNAL is set to "CAM").

50i: AJ-SPX900E camera unit operates in 50i mode.

25P: AJ-SPX900E camera unit operates in 25P mode.

To operate the camera in 25P mode, the vertical resolution mode must be selected through the menu option V.RES (25P). (effective when the menu option REC SIGNAL is set to "CAM").

INTRLCE: Line-mixed, natural video is recorded. This option is used to handle material that uses a standard interlaced signal.

PROG.: Non line-mixed, fully progressive, segmented-frame video is recorded. This option is used when HD conversion is performed, or when an editor and/or display output progressive signals.

Note that in progressive (25P) mode signals recorded on P2 cards are also converted from progressive scan (25P) to interlaced scan (50i).

<Note>

- When "VIDEO" is selected for the menu option REC SIGNAL, non-standard signals output from the GENLOCK IN connector, may degrade video quality.
- When "PROG." is specified for the menu option V.RES (25P), segmented-frame video is recorded, allowing you to perform completely progressive editing. However, adding vertical details (V.DTL) can makes the video appear unnatural. For these reasons, it is recommended that V.DTL be set to 0.
- In progressive mode, 50 percent shutter is forcibly added to produce more film-like motion video. To cancel this shutter, go to the <OPTION> screen from the OPTION menu and set the option P HALF SHUT to "OFF".

4-3-2 Selecting the Recording System

The recording format is selected through the option menu REC MODE.

The aspect ratio is selected through the menu option ASPECT. These options are found in the <SYSTEM MODE> screen, which is accessible from the SYSTEM SETTING page.

Details of the option REC MODE

- 50M:** Video is recorded in the DVCPRO50 format (50 Mbps).
- 25M:** Video is recorded in the DVCPRO format (25 Mbps).
- DV:** Video is recorded in the DV format.

Details of the option ASPECT

- 16:9:** Video is recorded with an aspect ratio of 16:9.
- 4:3:** Video is recorded with an aspect ratio of 4:3.

4-4 Selecting Audio Input Signals and Adjusting Recording Levels

In any format (DVCPRO50, DVCPRO or DV), the AJ-SPX900E supports independent four-channel audio recording. When the AUDIO SELECT CH1/CH2 switch is positioned at [AUTO], the recording levels for Audio Channels 1 and 2 are automatically adjusted. To manually adjust the recording levels, position the switch at [MAN]. Note that the recording levels for Audio Channels 3 and 4 are selected through a menu option.

4-4-1 Selecting Audio Input Signals

The input signals to be recorded on Audio Channels 1, 2, 3, and 4 are selected with the AUDIO IN switch. For more information, see [2-2 Audio (input) Function Section].

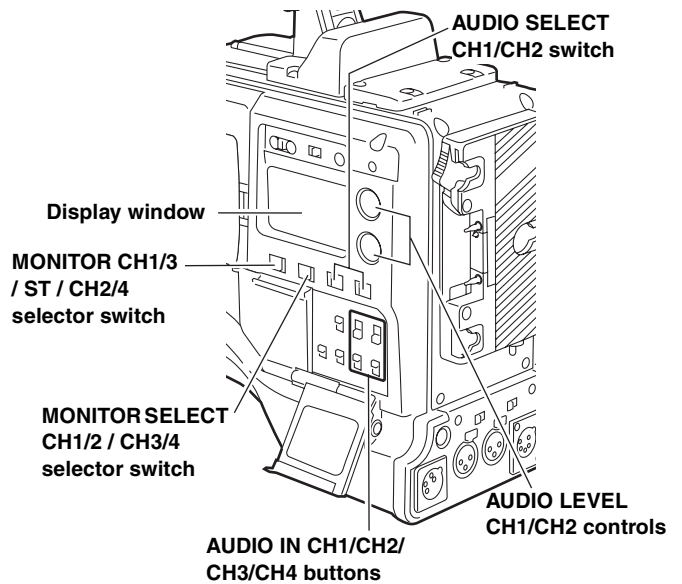

Your AJ-SPX900E is factory-set to perform no recording on Audio Channels 3 and 4 in the DVCPRO and DV formats. To enable four-channel recording, the menu option 25M REC CH SEL must be set to "4CH".

The following table shows audio signals recorded on Audio Channels 3 and 4 that depend on the settings for menu options REC CH3/4 and 25M REC CH SEL.

These options are found in the MIC/AUDIO1 screen, which is accessible from the MAIN OPERATION page:

REC CH3/4 options	25M REC CH SEL options	Recording on CH3/4	
		DVCPRO50 format	DVCPRO or DV format
SW	2CH	Audio signals selected with the AUDIO IN CH3/CH4 switch are recorded.	No recording is performed.
	4CH	Audio signals selected with the AUDIO IN CH3/CH4 switch are recorded.	Audio signals selected with the AUDIO IN CH3/CH4 switch are recorded.
CH1/2	2CH	Signals for Audio Channel 3 are also recorded on Audio Channel 1, and signals for Audio Channel 4 are also recorded on Audio Channel 2.	No recording is performed.
	4CH	Signals for Audio Channel 3 are also recorded on Audio Channel 1, and signals for Audio Channel 4 are also recorded on Audio Channel 2.	Signals for Audio Channel 3 are also recorded on Audio Channel 1, and signals for Audio Channel 4 are also recorded on Audio Channel 2.

<Note>

- Audio Channels 1 and 2 always receive the signals selected with the AUDIO IN CH1 and CH2 switches.
- When the extension board AJ-YA902AG (optional accessory) is attached, 4-channel recorded audio signals are SDI-output, as is.

Specific audio settings are performed through the <MIC/AUDIO1> and <MIC/AUDIO2> screens, which are accessible from the MAIN OPERATION page.

For more information, see [8-6 MAIN OPERATION].

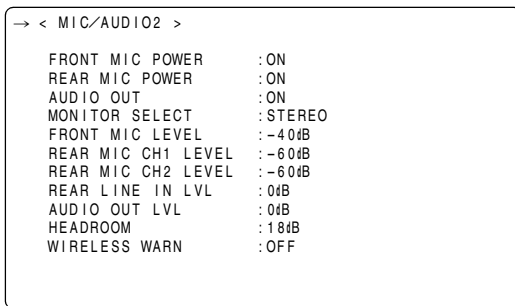
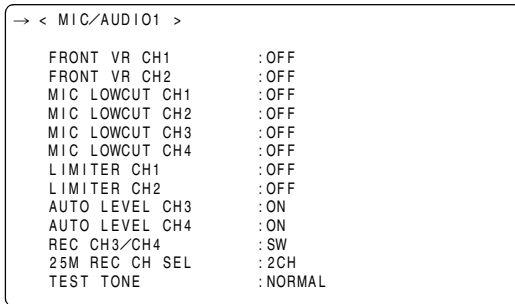

4-4-2 Adjusting Recording Levels

To adjust the recording levels for Audio Channels 1 and 2, follow the steps below.

1 Position the MONITOR SELECT CH1/2 / CH3/4-selector switch at CH1/2 so that the audio level meter on the display window will provide CH1 and CH2 indications. Ensure that the channel indications displayed in the window are 1 and 2.

Whether to enable or disable the FRONT AUDIO LEVEL control must be preset through menu options FRONT VR CH1 and FRONT VR CH2. Note that this control is factory-disabled.

The menu options are found in the MIC/AUDIO1 screen, which is accessible from the MAIN OPERATION page.

2 Position the AUDIO SELECT CH1/CH2 switch at [MAN].

3 While checking the audio channel level meter in the display window or the audio level meter in the viewfinder, adjust the AUDIO LEVEL CH1/CH2 control.

Note that if the level exceeds the top bar (0 dB), the word OVER illuminates to show that the input level is excessive. The adjustment made in such a way that the maximum level will not reach the 0 dB bar.

Audio level meter on the display window

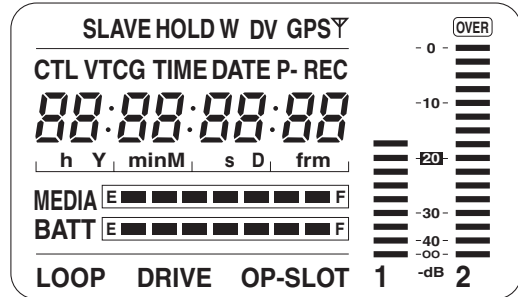

Audio level meter in the viewfinder



When operating the AJ-SPX900E without a sound recorder, it is recommended that the FRONT AUDIO LEVEL control should be used to adjust the audio level.

In advance, check the level meter in the viewfinder screen and use the AUDIO LEVEL control to adjust the appropriate audio channel so that no excessive audio signals will be admitted.

4-4-3 CH3 and CH4 Recording Levels

The following table shows the effects on the recording level for Audio Channels 3 and 4 that depend on the settings and input levels specified through the menu options AUTO LEVEL CH3 and AUTO LEVEL CH4. Note that the recording level cannot be adjusted manually.

These options are found in the <MIC/AUDIO1> screen, which is accessible from the MAIN OPERATION page.

AUTO LEVEL CH3/CH4	Input level	
	LINE	MIC
ON	AGC ON	AGC ON
OFF	AGC/LIMITER OFF	LIMITER ON

4-5 Setting Time Data

4-5-1 Setting the User Bits

The user bits allow information, including memos that use up to eight-digit base 16 numbers (date and time), to be recorded in the secondary code area.

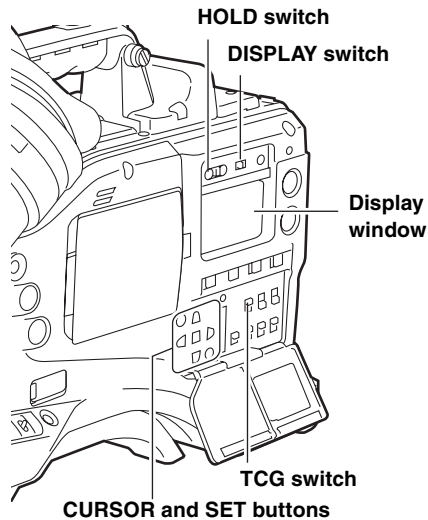

- 1** Position the DISPLAY switch at [UB].
- 2** Position the TCG switch at [SET].
When the left digit starts blinking you can change the value.
- 3** Use CURSOR buttons to set the user bits.
 - ▷ **button**: Shifts the target (blinking) digit to the right.
 - ◁ **button**: Shifts the target (blinking) digit to the left.
 - △ **button**: Advances the blinking number by one digit.
 - ▽ **button**: Winds back the blinking number by one digit.
- 4** Position the TCG at [F-RUN] or [R-RUN].
- 5** Go to the <TC/UB> screen from the MAIN OPERATION page, and set the menu option UB MODE to "USER".

<Note>

When the TCG switch is positioned at [SET], thumbnails cannot be manipulated.

Retaining the user bits

The data set for the user bits are automatically saved and retained even if the video camera-recorder is turned off.

Card continuity provided by the user's bit

If the menu option UB MODE is set to "REGEN", the AJ-SPX900E reads the user bits in the last frame of the last clip recorded on a P2 card (clip with the most recent recording date and time), and records that bit onto the next card. Note that settings for the user bits are not recorded.

The menu option UB MODE can be found in the <TC/UB> screen, which is accessible from the MAIN OPERATION page.

<Note>

The AJ-SPX900E also records the time code and user bits in the VIDEO AUX area. The value for the time code (VITC) is the same as that of the time code (LTC) in the sub-code area. The user bits (of VITC) also records special information, including the shooting frame rate.

User bits of VITC

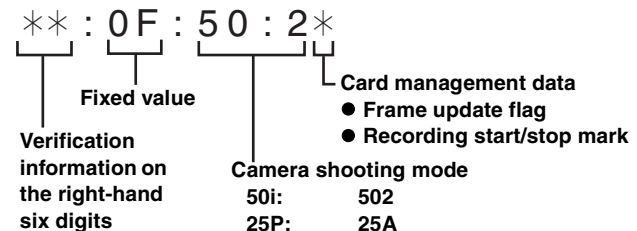

4-5-2 Setting the Internal Clock's Date and Time

- 1** Position the DISPLAY switch at [UB].
- 2** Press the HOLD button to display a date in the display window.
- 3** Position the TCG switch at [SET].
- 4** Use the CURSOR and SET buttons to set the year, month and day (Y/M/D).
Note that any later than 2030 cannot be set.
- 5** Press the HOLD button to display a time in the display window.
- 6** Use the CURSOR buttons to set the hour, minute and second (h/min/s).
- 7** Position the TCG switch at [F-RUN] or [R-RUN]. The internal clock starts at the moment the switch position is changed.
- 8** Press the HOLD button to display a time zone (time difference between local time and Greenwich Mean Time) in the display window.
- 9** Position the TCG switch at [SET].
- 10** Use the Δ and ∇ buttons to set the desired hours and minutes ahead of (no sign) or behind (– sign) the Greenwich Mean Time.

Example: If the local time is five hours behind Greenwich Mean Time, set the time zone to “5:00 –”.

The time zone is always recorded, together with the date and time, as metadata.
See the table at right to set the time zone according to your local time.
- 11** Position the TCG switch at [F-RUN] or [R-RUN] to accept the time zone.

<Notes>

- When using the camera-recorder for the first time, be sure to perform this setting beforehand. Do not change the setting during use of the camera-recorder.
- When the TCG switch is positioned at [SET], thumbnails cannot be manipulated.

Time difference	Area	Time difference	Area
00:00	Greenwich	– 00:30	
– 01:00	Azores Islands	– 01:30	
– 02:00	Mid-Atlantic	– 02:30	
– 03:00	Buenos Aires	– 03:30	Newfoundland Island
– 04:00	Halifax	– 04:30	
– 05:00	New York	– 05:30	
– 06:00	Chicago	– 06:30	
– 07:00	Denver	– 07:30	
– 08:00	Los Angeles	– 08:30	
– 09:00	Alaska	– 09:30	Marquesas Islands
– 10:00	Hawaii	– 10:30	
– 11:00	Midway Island	– 11:30	
– 12:00	Kwajalein	+ 11:30	Norfolk Island
+ 13:00		+ 10:30	Lord Howe Island
+ 12:00	New Zealand	+ 09:30	Darwin
+ 11:00	Solomon Islands	+ 08:30	
+ 10:00	Guam	+ 07:30	
+ 09:00	Tokyo	+ 06:30	Rangoon
+ 08:00	Beijing	+ 05:30	Bombay
+ 07:00	Bangkok	+ 04:30	Kabul
+ 06:00	Dacca	+ 03:30	Tehran
+ 05:00	Islamabad	+ 02:30	
+ 04:00	Abu Dhabi	+ 01:30	
+ 03:00	Moscow	+ 00:30	
+ 02:00	Eastern Europe	+ 12:45	Chatham Islands
+ 01:00	Central Europe		

<Notes>

- In Step 4, if the TCG switch is positioned at [F-RUN] or [R-RUN], this also activate the internal clock.
To cancel date, time and time zone settings in process, hold down the SET button and position the TCG switch at [F-RUN] or [R-RUN].
- Clock accuracy fluctuates between about ± 30 seconds per month when the power is turned off. If more accurate timekeeping is required, check the time when the power is turned on and, if necessary, reset the clock.
When the GPS unit AJ-GPS900G is installed, and if it successfully receives time information, the internal clock keeps accurate (local) time based on the received time (Greenwich Mean Time) and the time zone. If the date and time differ from the actual local time, the time zone may not be set correctly. Check again, to see if the time zone is set correctly. (The date and time need not be set again.)

4-5-3 Setting the Time Code

- 1 Position the DISPLAY switch at [TC].
- 2 Position the TCG switch at [SET].
- 3 Use the CURSOR buttons to set the time code.
The time code setting range extends from 00:00:00:00 to 23:59:59:24.
 - ▷ **button**: Shifts the target (blinking) digit to the right.
 - ◁ **button**: Shifts the target (blinking) digit to the left.
 - △ **button**: Advances the blinking number by one digit.
 - ▽ **button**: Winds back the blinking number by one digit.
- 4 Change the position of the TCG switch.
[F-RUN] steps the time code in free run mode, and [R-RUN] set it in recording run mode.

<Note>

When the TCG switch is positioned at [SET], thumbnails cannot be manipulated.

Regeneration of Time Code

When the menu option FIRST REC TC is set to "REGEN", the AJ-SPX900E reads the time code recorded in the last frame on the last recorded clip (with the most recent recording date and time) to maintain and record that value. The menu option FIRST REC TC can be found on the <TC/UB> screen, which is accessible from the MAIN OPERATION page.

<Note>

However, when a P2 card is inserted or removed or when the recording target P2 card is changed using the SLOT SEL function of the USER button, the time code is continuously recorded on the clip most recently recorded on the target P2 card. When there is no recorded clip, the time code is recorded on the new recording target P2 card, from the value generated by the TC generator built into the camera-recorder

Time code function during battery replacement.

Even during battery replacement the backup mechanism keeps the time code generator functioning for a considerable time (about one year).

<Note>

When the POWER switch has been switched ON → OFF → ON, the backup accuracy of the time code in free run mode is about ±2 frames.

4-5-4 Externally Locking the Time Code

The time code generator built into your AJ-SPX900E may be locked with an external generator. It is also possible to lock an external time code generator with the internal generator.

Connections for externally locking the time code (examples)

As illustrated, both the reference video signals and the time code must be input.

Example 1: Locking the time code with external signals

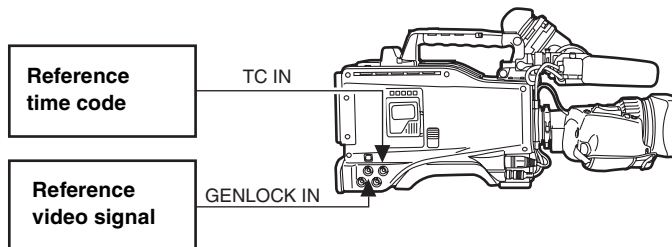

Example 2: Connecting two or more AJ-SPX900Es with one another, with one being used as the reference device.

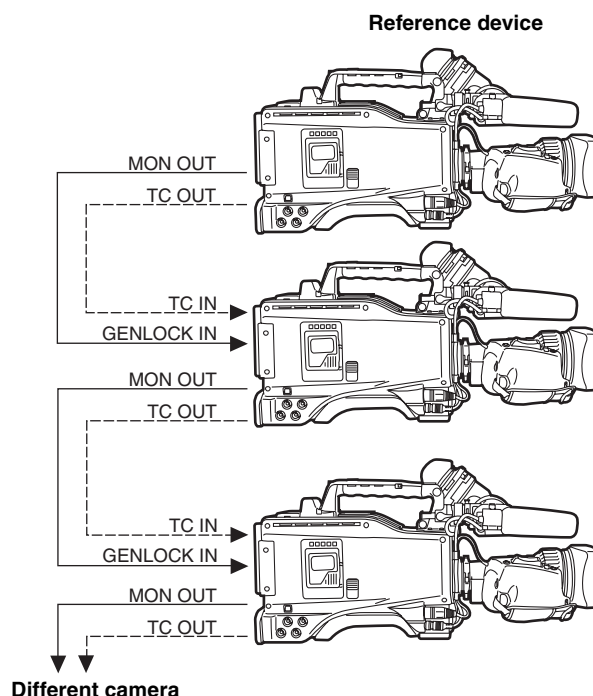

To externally lock the time code:

Follow the steps below.

- 1 Turn on the POWER switch.
- 2 Position the TCG switch at [F-RUN].
- 3 Position the DISPLAY switch at [TC].
- 4 Set the menu option GENLOCK to "EXT".
This option can be found in the <GENLOCK> screen, which is accessible from the SYSTEM SETTING page.
- 5 Supply a phase-relationship reference time code (that conforms to the time code requirements) and reference video signals to the TC IN and GENLOCK IN connectors, respectively.

Now the built-in time code generator is locked with the reference time code.

From about 10 seconds after locking the time code generator stays locked even if the supply of external reference time code is discontinued.

<Notes>

- When the time code generator is externally locked, the time code instantly becomes locked with the external time code, and the counter displays the external time code value. Do not put the AJ-SPX900E in recording mode before the sync generator stabilises.
- When the IEEE1394 interface board (AJ-YAD800G, optional) is attached, it is not possible to synchronize with the time code entered via the TC IN connector if "1394" is selected for the menu option REC SIGNAL. The menu option REC SIGNAL is found in the SYSTEM MODE screen on the SYSTEM SETTING page.

Setting the user bits when the time code is externally locked

When the time code is externally locked only time data is locked with the time data of the external time code.

This means that the user bits may be set separately for each camera-recorder.

When "EXT" is specified for the menu option UB MODE, the user bits is also locked with the user bits of the external time code.

The menu option UB MODE can be found in the <TC/UB> screen, which is accessible from the MAIN OPERATION page.

To unlock the externally locked time code:

Discontinue external time code supply, then position the TCG switch at [R-RUN].

Cautions in switching the power source from battery to external power supply

Connect the DC IN socket with the external power supply before removing the battery pack, in order to keep the time code generator energised. If the battery pack is removed first, there is no guarantee that the time code will stay externally locked.

External synchronisation of the camera when the time code is externally locked

When the time code is externally locked, the reference video signals input through the GENLOCK IN connector gen-lock the camera.

<Notes>

- To externally lock the AJ-SPX900E, as the master device, with more than one unit, the mode must be the same as that of the camera. Note that in a system using both interlaced and progressive scanning, there may be breaks in the video and time code.
- When using the MON OUT connector to output reference signals, position the OUTPUT SEL switch on the side panel at [CAM].

4-5-5 Providing an ID to the Camera

The camera ID is specified through the <CAMERA ID> screen. The ID can include up to 10 alphanumeric characters, symbols, and/or spaces.

<Note>

When the settings menu is displayed, outputting color bar signals does not indicate the camera ID.

- 1 Go to the <CAMERA ID> screen from the CAM OPERATION page.

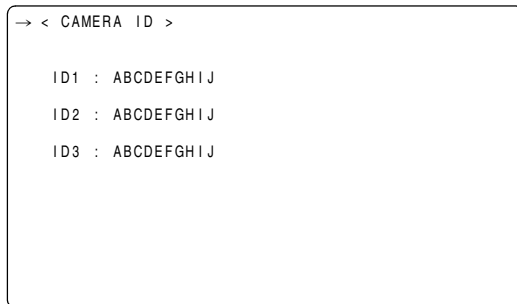

- 2 Turn the JOG dial button to move the cursor to options [ID1:] - [ID3:].
- 3 Press the JOG dial button. The cursor moves to the ID entry area, allowing you to enter an ID.
- 4 Turn the JOG dial button until a desired character appears. The characters that appear are switched in the following order:
Space: □
↓
Alphabetical characters: A to Z
↓
Numerals: 0 to 9
↓
Symbols: ', >, <, /, -
- 5 Press the JOG dial button to accept a desired character.
- 6 Turn the JOG dial button to move cursor to the next digit (clockwise), and repeat Steps 4 - 5 to set characters.
- 7 When all the characters are set, turn the JOG dial button to move the cursor to [:].
- 8 Pressing the JOG dial button brings the cursor back to the options [ID1:] - [ID3:].
- 9 To exit the menu, press the MENU button. The settings menu disappears and the status of the AJ-SPX900E is indicated at the top and bottom of the viewfinder screen.

<Note>

When the menu option CAMERA ID is set to "BAR", the camera ID is recorded together with color bar signals. This menu option is accessible from the <VF INDICATOR1> screen, which is accessible from the VF page.

4-5-6 Setting UMID Information

The AJ-SPX900E supports UMID metadata. You need to specify as UMID information the country where you live (using up to three characters), organisation or company (up to four characters) and user name (up to four characters). For the country name, you must use abbreviations prescribed in the ISO3166 Country Code*¹.

Here are some examples of the correct method for specifying a user name:

- *1 Examples:
- | | |
|--------|-----|
| China | CHN |
| U.S.A. | USA |
| Canada | CAN |
| Japan | JPN |

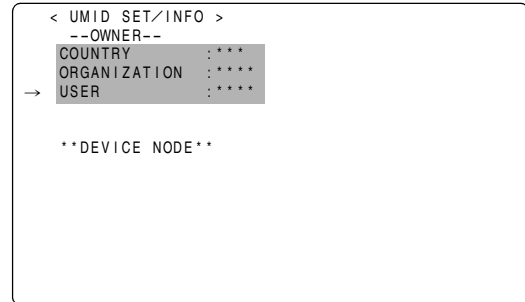

- 1 Go to the <UMID SET/ INFO> screen from the MAIN OPERATION page.
 - 2 Turn the JOG dial button to move the cursor to the option [USER].
 - 3 Press the JOG dial button. The cursor moves to the user entry area, allowing you to enter a user name.
 - 4 Turn the JOG dial button until a desired character appears. The characters appear in the following order:
Space: □
↓
Alphabetical characters: A to Z
↓
Numerals: 0 to 9
↓
Symbols: ', >, <, /, -
- <Note>
The COUNTRY entry can only include alphabetical characters and spaces.
- 5 Press the JOG dial button to accept a desired character.
 - 6 Turn the JOG dial button to move the cursor to the next digit (clockwise), and repeat Steps 4 to 5 to set characters.
 - 7 When the last character is set, press the JOG dial button to bring the cursor back to the option [USER].
 - 8 To exit the menu, press the MENU button.

4-5-7 CTL Count Setting and Display

By setting the DISPLAY switch to "CTL", CTL count is displayed on the time count indication of the LCD display window.

CTL count is displayed in ± 12 hours.

The playback order of clips recorded on a P2 card is not linear as for VTRs. It is organized according to thumbnail operations or exchanging P2 cards, and the priority of recorded clips will be altered. Therefore, different CTL counts are displayed for recording mode and playback mode, respectively.

CTL count for recording mode (recording CTL)

Recording CTL count is displayed during recording mode (REC, REC/PAUSE, STOP and REC REVIEW), and the count continues from the end point of the previous recording. Recording CTL count is retained even if the power is turned off. When the power is next turned on, the count continues from the previous value.

<Note>

If the RESET button is pressed while the recording CTL count is being displayed, only the recording CTL count is reset. Note that reset is disabled during the REC REVIEW operation.

CTL count for the playback mode (playback CTL)

During playback mode (PLAY, FF, REW, PLAY/PAUSE), playback CTL count is displayed.

Whenever the playback order of clips is altered (clips are sorted by shooting dates), previous playback CTL count is disabled. The first frame of the first clip is used as a reference value for recalculation, and the new playback CTL count is displayed.

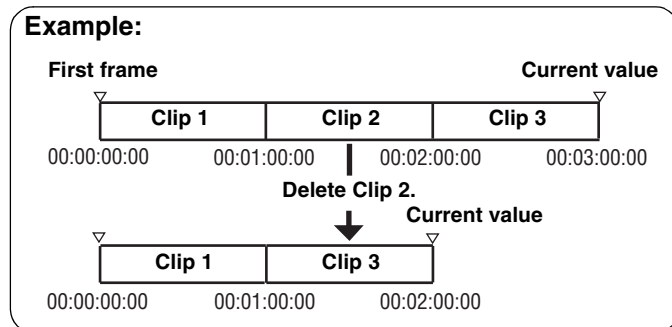

The playback order of clips is altered when either of the following occurs:

- Clips are deleted, copied or restored, or the P2 card is formatted.
- The thumbnail display is switched (for more information, see [6-5 Switching the Thumbnail Display]).
- A P2 card is inserted or removed.

The reference value (value of the first frame of the first clip) is changed when either of the following occurs:

- The power is turned on, the first frame becomes 0.
- When the playback CTL count is reset, the current playback position is set as 0, and the previous reference value becomes a negative value.

Example:

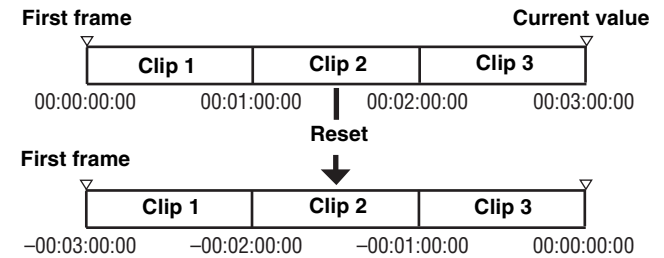

<Note>

If the RESET button is pressed while the playback CTL count is being displayed, only the playback CTL count is reset.

4-5-8 Mode Check Screen Displays (MODE CHECK button function)

The viewfinder can display a screen that allows you to check the settings and status of the AJ-SPX900E.

Each press of the MODE CHECK button switches the screen as follows:

STATUS screen → !LED screen → FUNCTION screen → AUDIO screen → No indication

Each screen is displayed for about three seconds. A press of the MODE CHECK button switches the current screen.

Whether or not to display each screen is specified through the <MODE CHECK IND> screen, which is accessible from the VF page.

```

→ < MODE CHECK IND >

STATUS           : ON
! LED            : ON
FUNCTION         : ON
AUDIO            : ON
P. ON IND       : ON
  
```

4-6 Menu Displays in the Viewfinder Screen

4-6-1 Menu Configuration

USER MENU: USER MENU is factory-set. The menu can be configured to suit your preferences by specifying each option according to your purposes and frequency of use, through the <USER MENU SELECT> screen, which is accessible from the MAIN MENU page.

For more information, see [4-6-3 Selecting Options for USER MENU].

To display USER MENU, press the MENU button.

MAIN MENU: Allows you to set all options on the settings menu. This menu has a category-by-category structure, layered according to purposes and frequency of use.

To display MAIN MENU, press the MENU button for three seconds or longer.

OPTION MENU: Provides options which may be needed if functions are added in the future.

To display OPTION MENU, hold down the LIGHT button and press the MENU button.

For more information, contact your local service center or distributor.

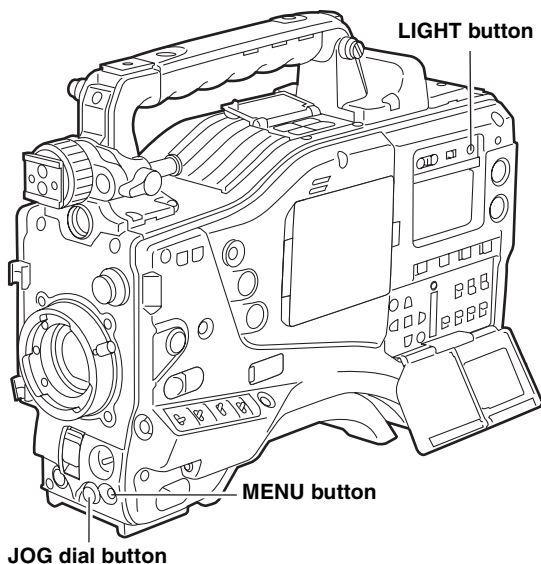

4-6-2 Setting Menu Options

The menu options are set with the MENU and JOG dial buttons. The menu comprises main menu, sub-menus and options menus.

The data specified through menu options are written and saved in the internal memory of the AJ-SPX900E.

This section describes how to set options in MAIN MENU. The other menus can be configured in the same manner (the method of displaying the menu screen depends on the particular menu).

<Note>

When the AJ-SPX900E is in thumbnail mode, the viewfinder displays "THUMBNAIL OPEN", disabling navigation through the menu.

- I** Press the MENU button for three seconds or longer. The MAIN MENU screen appears, together with its options.

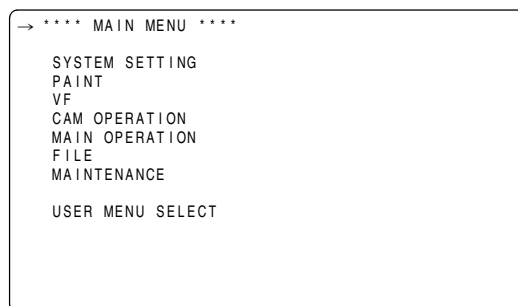

SYSTEM SETTING:

This option is used to specify recording signal, recording system, etc.

PAINT: This option is used to fine-adjust images while monitoring the output waveform of the camera, using the waveform monitor. Normally, this adjustment requires assistance from a video engineer.

This menu option may be set with an external remote controller, and is useful when using the AJ-SPX900E without a sound recordist.

VF: Used to select the information items to be displayed in the viewfinder screen.

CAM OPERATION:

Used to change settings according to the conditions for the subject.

MAIN OPERATION:

Used to specify recording-related items, such as audio settings, time code, battery and P2 card remaining amounts.

FILE: Used to specify file-related items such as SD memory card reading/writing and lens file settings.

MAINTENANCE:

Used to specify maintenance-related items.

USER MENU SELECT:

Used to edit USER MENU.

- Turn the JOG dial button to move the mark (→) to a desired menu option. Then, press the JOG dial button to display the sub-menu screen.

```

**** MAIN MENU ****

SYSTEM SETTING
PAINT
VF
→ CAM OPERATION
  MAIN OPERATION
  FILE
  MAINTENANCE

USER MENU SELECT
  
```

- Turn the JOG dial button to move the mark (→) to a desired menu option. Then, press the JOG dial button to display the options screen.

```

< CAM OPERATION >

CAMERA ID
SHUTTER SPEED
SHUTTER SELECT
→ USER SW
  SW MODE
  WHITE BALANCE MODE
  USER SW GAIN
  IRIS
  
```

- Turn the JOG dial button to move the mark (→) to a desired option. Then, press the JOG dial button. The value starts blinking.

```

< USER SW >

→ USER MAIN SW :S.GAIN
  USER1 SW      :DS.ZOOM
  USER2 SW      :DS.GAIN
  
```

- Turn the JOG dial button to change the value.

To increase the value:

Turn the JOG dial button clockwise, as seen from the front of the camera.

To decrease the value:

Turn the JOG dial button anti-clockwise, as seen from the front of the camera.

Each turn of the dial switches the value by one step. A quick turn changes the value rapidly; a slow turn makes a fine adjustment.

To turn an option on or off:

To select ON, turn the JOG dial button clockwise, as seen from the front of the camera.

To select OFF, turn the JOG dial button anti-clockwise, as seen from the front of the camera.

- Press the JOG dial button. The value stops blinking and is accepted.

- To change the settings for other options on the same page, repeat Steps 4 - 6.

- When the settings are finalised, press the MENU button. This terminates the menu option setting mode and returns the AJ-SPX900E to normal operation mode.

4-6-3 Selecting Options for USER MENU

Go to the USER MENU SELECT page from MAIN MENU. Then, open relevant options menu screens to select options to add to USER MENU.

Only the selected options are displayed as options in USER MENU.

For information about how to navigate this menu, see [4-6-2 Setting Menu Options].

```

< USER MENU SELECT > (SELECT MODE)

→ SYSTEM SETTING
  PAINT
  VF
  CAM OPERATION
  MAIN OPERATION
  FILE
  MAINTENANCE
  
```

<Note>

Options with [*] are effective. The number of options that can be added to USER MENU is 14 × 3 = 42 (three pages of options) for camera-related options, and 14 (one page of options) for memory-related options.

4-7 Viewfinder Screen Status Displays

In addition to video images, the viewfinder displays lamps and text that indicate the settings and operating status of the AJ-SPX900E, together with messages, a center marker, a safety zone marker and the camera ID.

4-7-1 Lamps in the Viewfinder Screen

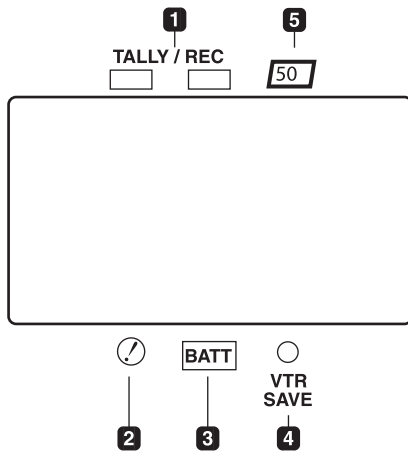

The above viewfinder is the AJ-VF20WB (for further information on your optional viewfinder model, see the relevant instruction manual).

1 TALLY/REC (recording) Lamp

This lamp stays illuminated during recording, and starts blinking if any abnormal action occurs.

For more information, see [7-3 Warning System].

2 Abnormal Operating Status Warning Lamp

This lamp comes on when the AJ-SPX900E is in any of the abnormal operating statuses specified through the menu sub-option !LED.

For statuses that activate the lamp, see the options in the <!LED> screen in [8-4-7 !LED].

2 BATT (battery) Lamp

This lamp starts blinking a few minutes before the battery charge starts to run out, and stays illuminated after the battery is completely flat. The battery should be replaced before it is nearly flat, so that operation will not be interrupted.

For more information, see [7-3 Warning System].

4 SAVE Lamp

In the normal setting:

The lamp stays on when the SAVE switch is positioned at [ON] and the output of video and audio is power-saved.

When the menu option SAVE LED is set to "P2 CARD":

The lamp comes on when the P2 card remaining free space is getting low.

The menu option SAVE LED can be found in the <VF INDICATOR2>, which is accessible from the VF page.

5 50 (50-Mbps recording/playback) Lamp

This lamp stays illuminated when the AJ-SPX900E is set to the DVCPRO50 (50 Mbps) format, and when playback is being performed in the DVCPRO50 format.

Note that the lamp is factory-disabled. For more information, see the relevant section of the menu option 50M INDICATOR in [8-4-1 VF DISPLAY].

4-7-2 Viewfinder Status Indication Layout

The indications are arranged as illustrated below.

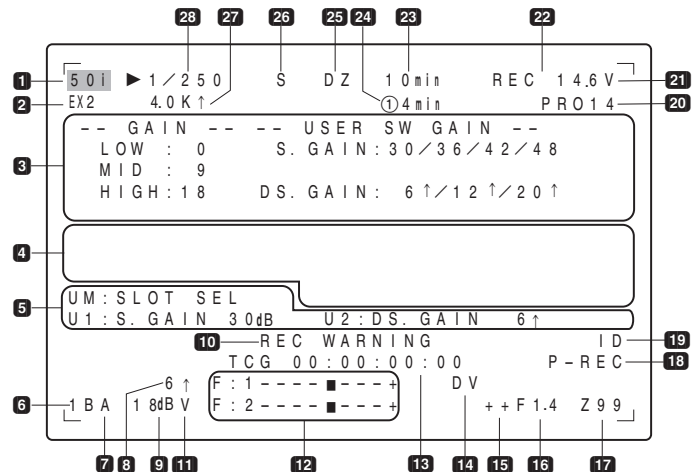

For more information, see the following pages:

4-7-3 Selecting Viewfinder Display Information

To select the information items you want to have displayed in the viewfinder screen, go to the <VF INDICATOR1> and <VF INDICATOR2> screens from the VF page, and turn on or off the appropriate options, or specify desired values.

For directions on setting the options, see [4-6-2 Setting Menu Options].

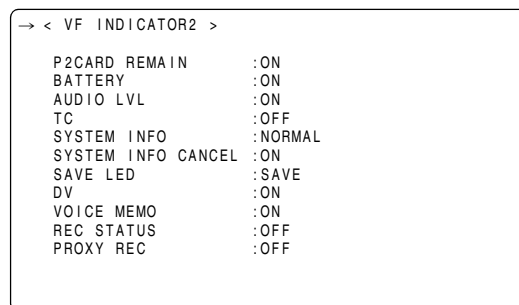
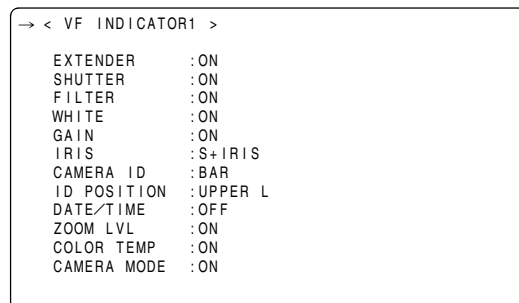

Information Item	Indication	Status
1 Camera Shooting Mode	50i, 25P	Camera shooting mode (progressive or interlaced)
2 Extender	EX2	Lens extender used.
3 MODE CHECK Indication Area (STATUS: Master gain, USER SW GAIN)	LOW/MID/HIGH -3 to 30 S.GAIN 30/36/42/48 DS.GAIN 6 ↑ /12 ↑ /20 ↑	Value set for the master gain Example: LOW: 0 Gain value to which S.GAIN and DS.GAIN are assigned
(Cause of !LED illumination: displayed full-screen) ● Indications selected through the menu option !LED are marked with [!]. ● Indications which may activate the !LED are marked with [!].	GAIN (0 dB) GAIN (-3 dB) DS.GAIN SHUTTER WHITE PRE. EXTENDER BLACK STR. MATRIX COLOR COR. FILTER SUPER V 50M/25M/DV ATW D.ZOOM	Gain status Gain status DS. GAIN value Shutter status White balance status Extender status (EX2 or OFF) Black stretch status (ON or OFF) MATRIX status (A, B, or OFF) Color correction status (ON or OFF) Filter status SUPER V status (ON or OFF) Recording mode (50M, 25M, or DV) ATW status (ON or OFF) Digital zoom status (ON or OFF)
(FUNCTION: VIDEO OUT)	SW: MEM/CAM/OFF SELECT: VBS/VF/Y/SDI CHAR: ON/OFF	Position of OUTPUT SEL switch. Setting for menu option VIDEO OUT SEL. This option can be found in the <OUTPUT SEL> screen, which is accessible from the SYSTEM SETTING page. Position of VIDEO OUT CHARACTER switch
(FUNCTION: MONI OUT)	SW: MEM/CAM/OFF CHAR: ON/OFF	Position of OUTPUT SEL switch. The setting for menu option MONITOR OUT CHAR. This option can be found in the <OUTPUT SEL> screen, which is accessible from the SYSTEM SETTING page.
(FUNCTION: P2CARD STATUS)	TOTAL SLOT1/SLOT2/SLOT3/SLOT4/ SLOT5 OP-SLOT	Total remaining free space/capacities of the P2 cards loaded in P2 Card Slots 1 - 5 Remaining free space/capacity of each card. The numbers denote the P2 card slot numbers. The card status is indicated as: ACTIVE/ACTIVE!/ACCESSING/INFO READING/FULL/PROTECTED/ NOT SUPPORTED/FORMAT ERROR/NO CARD/PROXY For details of statuses, see [P2 CARD ACCESS LED and status of P2 cards] (page 24). Indicates optional slot status. The card status is indicated as: PROXY/NO CARD/NOT SUPPORTED
(AUDIO: Enabling or disabling the FRONT AUDIO LEVEL control)	CH1: ON/OFF CH2: ON/OFF	If the FRONT AUDIO LEVEL control is in effect for Channel 1, then ON is indicated. If not, OFF is indicated. If the FRONT AUDIO LEVEL control is in effect for Channel 2, then ON is indicated. If not, OFF is indicated.
(AUDIO: Power status for the microphone)	FRONT: ON/OFF REAR: ON/OFF	Power status of the front microphone Power status of the rear microphone For more information, see [8-6-5 MIC/AUDIO2].
(AUDIO: Input signal and level for each channel)	FRNT/W.L./REAR CH1/2/3/4	Input signal and level for each channel

Information Item	Indication	Status
4 Camera Warning and Report Area (related to AWB, ABB and switch settings)	AWB A ACTIVE AWB B ACTIVE AWB A OK *.*K AWB B OK *.*K AWB BREAK *.*K AWB NG COLOR TEMP LOW COLOR TEMP HIGH LEVEL OVER LOW LIGHT TIME OVER AWB PRESET *.*K ATW MODE CHECK FILTER AWB A VAR *.*K AWB B VAR *.*K ABB ACTIVE ABB OK ABB BREAK ABB NG W-SHD ACTIVE W-SHD OK W-SHD BREAK W-SHD NG LVL OVER B-SHD READY B-SHD ACTIVE B-SHD OK B-SHD BREAK B-SHD NG	AWB being performed on Ch A. AWB being performed on Ch B. AWB successful on Ch A. AWB successful on Ch B. AWB action aborted by user. AWB action failed. The second line indicates the status. Color temperature too low. Color temperature too high. Brightness too high. Brightness too low. Action timed-out. AWB cannot proceed because the AWB switch is positioned at [PRE]. AWB cannot proceed during ATW. Make sure the FILTER control is positioned correctly. AWB cannot proceed because [A] is set to "VAR". AWB cannot proceed because [B] is set to "VAR". ABB being performed. ABB action successful. ABB action aborted by user. ABB action failed. White shading being adjusted. White shading has been adjusted. White shading action aborted by user. White shading adjustment failed due to excessive brightness. Black shading accepted (by holding down the ABB switch during ABB adjustment). Black shading being adjusted. Black shading adjustment successful. Black shading adjustment aborted by user. Black shading adjustment failed.
(Switch changeover indication)	WHITE: # *.*K AUTO KNEE: ON/OFF GAIN: **dB SS: 1/***** SS: ► 1/***** SS: SUPER V CC: ***** ** K ND: * EXTENDER: ON/OFF IRIS: ** F *.*	The WHITE BAL switch has been switched. # is replaced with A, B or PRE. When [A] and [B] are set to "VAR", then it is indicated as VAR *.* K. When [B] is assigned ATW, then it is indicated as ATW MODE. AUTO KNEE switch has been switched to ON or OFF. Gain has been switched with the GAIN selector switch or a user button. When the shutter speed has been switched, the shutter speed is indicated. Shutter speed is in SYNCRO SCAN mode. Shutter speed is in SUPER V mode. Indicated when the CC filters are switched. Indicated when the ND filters are switched. Lens extender has been turned on or off. Indicated when the iris override correction value is to be changed.
(Low light warning)	LOW LIGHT	Brightness too low.
(CALL indication)	CALL	Displayed when CALL command is issued from the extender.
(Y GET value)	***.*%	When the Y GET function is being carried out (the output brightness level near the center marker is being measured for about three seconds: the level is represented as a percentage), the output brightness level near the center marker is indicated as a percentage.
(MARKER indication)	MKR: A/B/OFF	Current marker type
5 User button functions UM: USER MAIN button U1: USER1 button U2: USER2 button	INH S.GAIN **dB/OFF DS.GAIN ** ↑ /OFF S.IRIS ON/OFF I.OVR ON/OFF S.BLK -**/OFF B.STR ON/OFF AUDIO CH1 AUDIO CH2 REC SW Y GET ON RET SW ATW ON/OFF D.ZOOM ON/OFF NEWS-G ON/OFF SLOT SEL	User buttons disabled. Selected S.GAIN Selected DS.GAIN Whether S.IRIS is ON or OFF. Iris override can be set (the IRIS OVERRIDE setting is ON). Status of SUPER BLACK (ON or OFF). When it is ON, the set value is also indicated. Status of BLACK STRETCH (shade correction for the black level): ON or OFF Input signal to be recorded on Audio Channel 1 has been switched. Input signal to be recorded on Audio Channel 2 has been switched. USER button acts as REC switch. Y GET function ON. USER button acts as RET switch. ATW being performed. Status of the digital zoom (ON or OFF) Status of News Gamma (ON or OFF) Switch that changes the target card is set.
6 Filter positions	1 - 4 A - D -	Position of the ND filter. Position of the CC filter. Filter not positioned correctly.
7 WHITE BAL switch position	A B P T	WHITE BAL switch positioned at [A]. WHITE BAL switch positioned at [B]. WHITE BAL switch positioned at [PRE]. ATW mode active. When brightness and color are outside operating limits, the indication blinks.

Information Item	Indication	Status
8 Stored gain indication	6 ↑ /12 ↑ /20 ↑	Storage gain (DS.GAIN) value (when active)
9 Gain value	**dB	Current gain value.
10 System information and warnings	SYSTEM ERROR-** TURN POWER OFF REC WARNING BACKUP BATT EMPTY WIRELESS-RF EOM BOS EOS CANNOT REC CANNOT PLAY COMM ERROR VOICE CANNOT REC VOICE REC VOICE OFF VOICE PLAY MARK ON/OFF UPDATING USB DRIVE THUMBNAIL OPEN 1394 INITIAL ERROR PROXY REC P2&SD PROXY REC P2 EOM (SD) PROXY CARD ERROR SD CARD WRITE ERR	Something abnormal is happening to the internal computer communications or reference signal. No further recording or playback can be performed. ** is replaced with an error code. For more information, see [7-3-2 Error Codes]. P2 card has been removed while being accessed (recorded, played back, or formatted), and subsequent operation is disabled. Something abnormal is happening to video and/or audio being recorded. Backup battery needs replacing. RF signal from the wireless receiver is degraded. P2 card has no free space. Playback position is at the start of all the clips. Playback position is at the end of all the clips. The P2 card is not recordable. Detailed information is provided on the FUNCTION screen of MODE CHECK 3 . See the relevant section of the MODE CHECK area. Clip cannot be played back perhaps because no P2 card is loaded, or the P2 card contains no clips. Displayed when disconnection between microcomputers continues for a specified period or longer. Voice memos cannot be recorded, possibly perhaps because the P2 card has no free space, or 100 voice memos are already recorded on one clip. Voice memo being recorded. Recording of voice memo stopped. Voice memo being played back. Shot mark been added or deleted. For information on shot marks, see [3-10 Shot Mark Function]. Clip information is being updated. Playback operation disabled. AJ-SPX900E is in USB mode. When communication is disabled, the indication blinks. Thumbnail is being manipulated. Displayed when the connection of the DVCPRO/DV connector is abnormal (when AJ-YAD800G is attached). Displayed when proxy recording on either the P2 card or the SD memory card starts (when AJ-YAX800G is attached). Displayed when proxy recording on the P2 card starts (when AJ-YAX800G is attached.). Displayed when full capacity is reached during proxy recording on the SD memory card (when AJ-YAX800G is attached). Displayed when proxy recording stops because of failure on either the video encoder card or the stream. (when AJ-YAX800G is attached). Displayed when a failure occurs on the SD memory card during proxy recording, and only recording on the SD memory card stops. (when AJ-YAX800G is attached).
11 Voice memo indication	V	Voice memo being recorded. When the free space for voice memos is less than one minute, the indication blinks.
12 Audio input channel and level meter	- - - - ■ - - - - + F W R	Selected channel together with its audio level. AUDIO IN switch is positioned at FRONT. AUDIO IN switch is positioned at WIRELESS. AUDIO IN switch is positioned at REAR.
13 Time code indication	TCG 12:59:59:20 TCR 12:59:59:20 (V)UBG AB CD EF 00 (V)UBR 12 34 56 78 CTL -1:59:59:20	TCG (time code generator value) TCR (time code reader value) UBG VUBG UBR VUBR. Displays CTL count.
14 DV format indication	DV	DV format specified and playback being performed in the DV format.
15 Iris override indication	+ + + (No indication) - - -	Correction phase of the iris override (when active) + + : On the open side by 1 +: On the open side by 0.5 - - : On the closed side by 1 -: On the closed side by 0.5 No indication : Standard status
16 Iris, F value	NC OPEN F1.7 - F16 CLOSE	Lens cable is not connected. Lens iris is at maximum. Lens iris value Lens iris closed. <Note> These indications are provided when the lens is capable of indicating the iris value. When the iris is being overridden, they blink.
17 Zoom indication	Z00 - Z99	Zoom degree is indicated. This indication is not provided for a lens that does not return the zoom position, even if the indication is set to ON.

Information Item	Indication	Status
18 INTERVAI REC/PRE RECORDING indication	i iREC (blink) iREC (blink) **h**m/**s P-REC (blink)	Displayed when the REC button is disabled before the start or after the end of INTERVAL REC mode. Displayed during INTERVAL REC operation. Displays the pause time before the next recording during INTERVAL REC. Indicated while pre-recorded video and audio are being recorded on the P2 card.
19 ID record indication	ID	The ID is set to be superimposed on the video from the camera.
20 Battery type	PRO14 - AC_ADPT	Battery type, selected through a menu option. When the AC adapter is connected, it is indicated as AC_ADPT.
21 Battery remaining level/voltage	**.*V ***% EMP MAX	Battery remaining level in tenths of a volt Digital battery remaining level, as a percentage Digital battery empty. Digital battery fully charged.
22 Camera-recorder REC indication	REC	When the AJ-SPX900E is used as a system camera using a 26-pin extender or Triax, the recording status of the camera-recorder is displayed using characters. The indication stays illuminated during recording. This is displayed when the menu option REC TALLY of the SYSTEM MODE is set to "CHAR". This can also be displayed during the recording using the AJ-SPX900E alone. This is displayed when the menu option REC STATUS of the VF INDICATOR2 is set to "ON".
23 P2 card remaining free space	**.*min END WP LOOP INFO P2 */*	The indication "**.*min" stays illuminated under normal conditions or blinks when the remaining level is near zero. When the card space is used up, "END" comes on. The P2 card is write-protected. The camera-recorder is in LOOP REC mode. When loop recording cannot be performed, for example because the P2 card has no free space, the indication blinks. P2 card being recognised. Total free space/capacities of the P2 cards (when MODE CHECK is being performed). <Note> When the menu option P2 CARD REMAIN is set to "ONE CARD", the number of the P2 card slot that contains the target card is indicated, together with the remaining space. For more information, see [P2 Card Remaining Free Space/capacity Indication] (page 53).
24 P2 card remaining free space (when MODE CHECK is being performed)	①**.*min	The number of the P2 card slot that contains the target card and the remaining free space (when MODE CHECK is being performed) are indicated. In LOOP REC mode, the minimum guaranteed recording time is indicated. This indication also appears when the target P2 card has been switched with a user button. The minimum guaranteed recording time refers to the sum, at the time loop recording is stopped, of the remaining free space of available P2 cards, except for the card with the largest remaining free space. Example: If three P2 cards are available, with remaining space of eight minutes, five minutes and two minutes respectively, then the minimum guaranteed recording time is seven minutes.
25 D.ZOOM	DZ	Camera-recorder in digital zoom mode. Note that the indication blinks while the camera-recorder is in FOCUS mode.
26 Super iris ON/super black ON	S B SB	Super iris ON. Super black ON. Super iris and super black both ON.
27 Color temperature	*.* K	Color temperature assigned to A, B, and PRE of the WHITE BAL switch (this is a value stored at AWB performance or a value set through the menu option). The indication is not provided in ATW mode.
28 Shutter speed/mode	▶1/**.* 1/60 - 1/2000 SUPER V	Shutter speed set to SYNCHRO SCAN. Shutter speed fixed. Shutter speed set to SUPER V (high vertical resolution mode).

P2 Card Remaining Free Space/capacity Indication

Status of AJ-SPX900E	Recording status	Menu option P2 CARD REMAIN*	23 P2 card remaining free space indication	24 P2 card remaining free space indication (during MODE CHECK)
Under normal conditions	Other than LOOP REC mode	TOTAL	The total remaining free space of all P2 cards loaded in the P2 card slots is indicated in minutes. Example: 30min	Not provided
		ONE CARD	The number of the P2 card slot holding the target P2 card, together with that card's remaining free space indicated in minutes. Example: 18min	Not provided
		OFF	Not provided	Not provided
	LOOP REC mode	TOTAL/ONE CARD	Indicated as [LOOP]	Not provided
		OFF	Not provided	Not provided
During MODE CHECK	Other than LOOP REC mode	TOTAL/ONE CARD/ OFF	The total remaining free space and capacities of all P2 cards loaded in the P2 card slots are indicated in minutes. Example: 20/40	The number of the P2 card slot holding the target P2 card, together with that card's remaining free space, indicated in minutes. Example: 18min
	LOOP REC mode		Indicated as [LOOP]	The minimum guaranteed recording time is indicated in minutes. Example: 7min

*The menu option P2CARD REMAIN can be found in the <VF INDICATOR2> screen, which is accessible from the MAIN OPERATION page.

Indications Available in the Viewfinder Screen

	Selectable between on and off through menu options	Provided when the appropriate status is encountered.	Provided during MODE CHECK*1	Selectable	Provided during playback
1 Camera shooting mode	○	—	●	○	—
2 Extender	○	○	●	○	—
3 MODE CHECK indication area	—	—	○	○	—
4 Camera warning and report area	—	○	○	○	—
5 User button functions	—	○	○	○	—
6 Filter position	○	—	●	○	—
7 WHITE BAL switch position	○	—	●	○	—
8 Stored gain indication	○	—	●	○	—
9 Gain value	○	—	●	○	—
10 System information and warnings	○	○	●	○	○
11 Voice memo indication	○	○	●	○	○
12 Audio input channel and level meter	○	—	All 4ch input information	○	—
13 Time code indication	○	—	●	○	○
14 DV format indication	○	○	●	○	○
15 Iris override indication	○	○	●	○	—
16 Iris, F value	○	—	●	○	—
17 Zoom indication	○	—	●	○	—
18 INTERVAL REC/PRE RECORDING indication	—	○	●	—	—
19 ID record indication	—	○	●	—	—
20 Battery type	—	—	●	○	—
21 Battery remaining level/voltage	○	—	●	○	—
22 Camera-recorder REC indication	○	○	●	○	—
23 P2 card remaining free space	○	—	●	○	—
24 P2 card remaining free space (MODE CHECK)	—	—	●	○	—
25 D.ZOOM	—	○	●	○	—
26 Super iris ON/super black ON	○	○	●	○	—
27 Color temperature	○	○	●	○	—
28 Shutter speed/mode	○	○	●	○	—

*1 ○: Not provided when the menu option STATUS is set to OFF, which can be found in the <MODE CHK IND> screen, accessible from the : VF page.

●: Provided regardless of the menu option setting.

4-7-4 Display Modes and Setting Changes/ adjustment Result Messages

The messages that appear on the viewfinder screen to indicate changes to settings and adjustment results may be limited, or set not to appear, through the menu option DISP MODE. This menu option can be found in the <VF DISPLAY> screen, which is accessible from the VF page.

For directions on navigating the menu, see [4-6-2 Setting Menu Options].

```

-> < VF DISPLAY >

DISP CONDITION      :NORMAL
DISP MODE           :3
VF OUT              :Y
VF DTL              :3
ZEBRA1 DETECT       :070%
ZEBRA2 DETECT       :085%
ZEBRA2              :SPOT
LOW LIGHT LVL       :35%
ECU MENU DISP.      :OFF
50M INDICATOR       :OFF
MARKER/CHAR LVL     :50%
    
```

Settings Change/adjustment Result Messages and DISP MODE Settings

Message appears when:	Message	DISP MODE settings		
		1	2	3
CC/ND filter changed.	CC: n (n=1, 2, 3, 4) or ND: m (m=A, B, C, D)	×	×	○
Gain changed.	GAIN: n dB (n=-3, 0, 3, 6, 9, 12, 15, 18, 21, 24, 27, 30)	×	×	○
WHITE BAL switch re-positioned.	WHITE: n (n=A, B, PRE)	×	×	○
OUTPUT/AUTO KNEE switch positioned at [AUTO KNEE] or [OFF].	AUTO KNEE: ON (or OFF)	×	○	○
Shutter speed/mode changed.	SS: 1/60 (or 1/120, 1/250, 1/500, 1/1000, 1/2000, ▶ 1/**.*)	×	○	○
White balance adjusted (AWB performed).	Example: AWB A OK 3.2 K	×	○	○
Black balance adjusted (ABB performed).	Example: ABB OK	×	○	○
Extender selected.	Example: EXTENDER ON	×	×	○
USER button selected.	Example: UM: S.GAIN 30 dB	×	○	○
MARKER SELECT button selected.	Example: MKR: A	×	×	○
Iris being overridden.	Example: ++ F 5.6	×	○	○

○: Message appears.

×: Message does not appear.

4-7-5 Setting the Marker Displays

The center, safety zone, safety zone area and frame markers may be set to ON or OFF, along with specifications of the marker types. To set and select markers, go to the <VF MARKER> screen from the VF page and select the appropriate options. For directions on navigating the menu, see [4-6-2 Setting Menu Options].

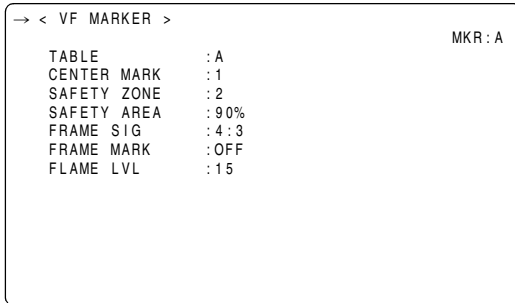

<Note>

The indication MKR:A at the upper right of the screen shows the current indication status. To view TABLE B, press the MARKER SELECT button. This changes the indication to MKR:B, allowing you to view the settings.

4-7-6 Marker Check Screen Displays (MARKER SELECT button function)

The viewfinder can display a screen that allows you to view the marker settings of the AJ-SPX900E. Pressing the MARKER SELECT button on the camera-recorder switches the marker indication as follows.

Marker A → Marker B → No marker

If the menu option FRAME SIG is set to 16:9 as the information of Marker A and 4:3 as the information of Marker B, then the 16:9 and 4:3 view angles can easily be checked with the button, as required.

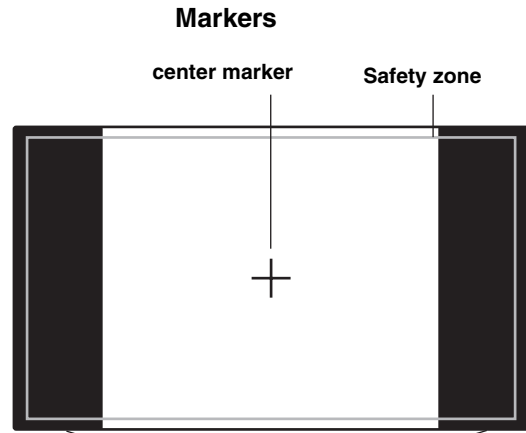
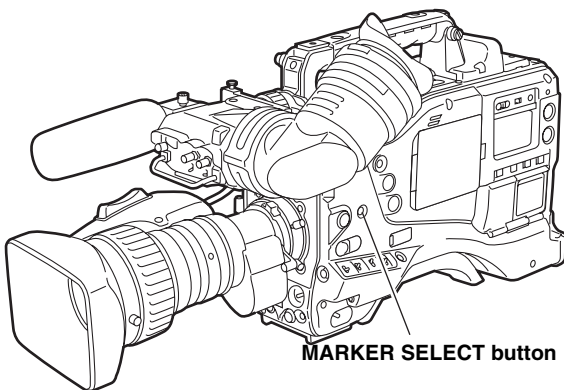

The view angle specified through the menu option FRAME SIG is displayed.

4-7-7 Checking Return Video Signal in the Viewfinder

The viewfinder displays the return video signal input to the GENLOCK IN connector while the RET button at the lens is held down.

To enable this capability, select CAM RET for the menu option RET SW. This option can be found in the <SW MODE> screen, which is accessible from the CAM OPERATION page.

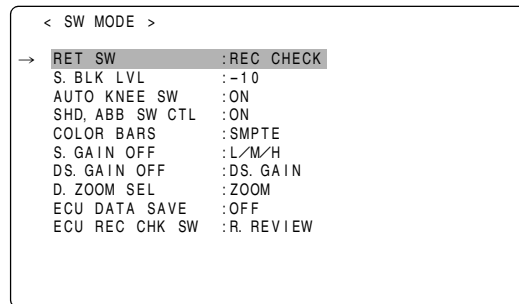

4-8 Adjusting and setting the LCD monitor

Using the LCD Monitor

- 1 Turn on the POWER switch of the AJ-SPX900E.
- 2 Slide the OPEN button in the arrow ① direction to open the LCD monitor.

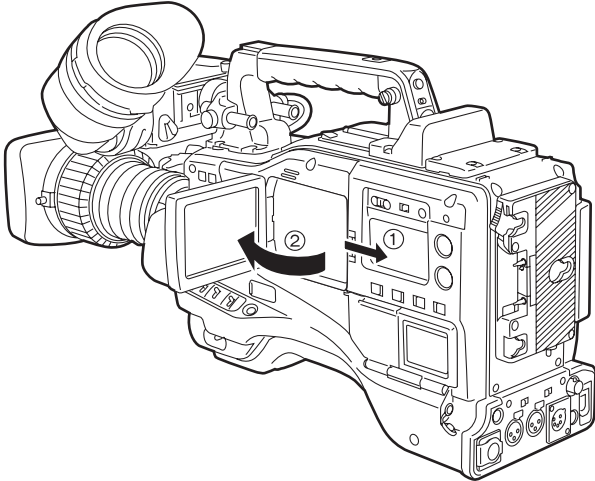

- 3 Adjust the angle of the LCD monitor for most convenient viewing. The monitor can turn up to 180 degrees towards the lens and up to 90 degrees towards you.

<Note>

To prevent camera-recorder failure, do not allow undue force to be applied to the monitor (when it is open).

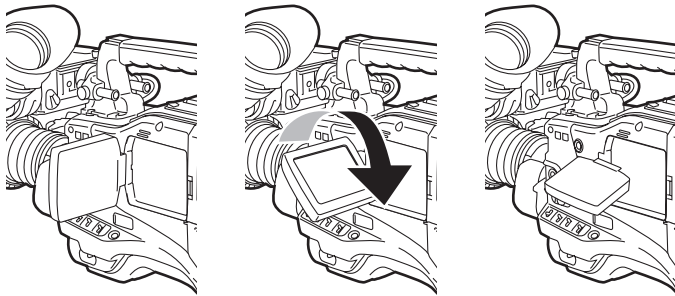

- 4 The options BRIGHTNESS, COLOR LEVEL, and CONTRAST show respectively the brightness, color level and contrast of the screen. These options can be found in the <LCD MONITOR> screen, which is accessible from the SYSTEM SETTING page.

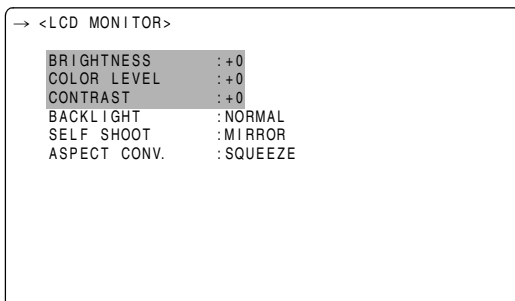

- 5 Through the menu option LCD MON CHAR, specify whether or not the LCD should display the same characters as the viewfinder. This menu option can be found in the <OUTPUT SEL> screen, which is accessible from the SYSTEM SETTING page.

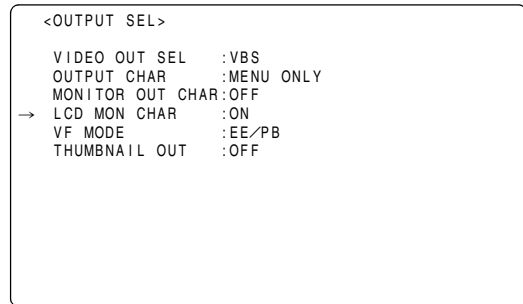

<Notes>

- When closing the LCD monitor make sure that it is shut tight.
- In an environment with sudden temperature changes, condensation may form on the liquid crystal surface of the monitor. If this happens, wipe off the moisture with a soft, dry cloth.
- When the camera-recorder is very cold, the video image in the LCD monitor will appear slightly darker immediately after the power is turned on. Once the interior of the camera-recorder warms up, the LCD monitor delivers normal brightness.

Self-portrait Shooting

When shooting with the LCD display angled 180 degrees towards the lens, you can set the menu option SELF SHOOT to "MIRROR", to horizontally flip the video image on the LCD display, and allow you to view a mirror image while shooting. Note that only the video image on the LCD monitor is horizontally flipped, not the actual video being recorded. The menu option SELF SHOOT can be found in the <LCD MONITOR> screen, which is accessible from the SYSTEM SETTING page.

<Note>

When the LCD monitor is angled 180 degrees towards you with the menu option SELF SHOOT to "MIRROR", the LCD monitor does not provide the same status indication as the viewfinder, regardless of the setting for the menu option LCD MON CHAR.

4-9 Menu-driven Function Setup

Each function is set up using the menu system.

4-9-1 Setting the Switchover of USER SW GAIN

In addition to the standard L/M/H gain mode, the AJ-SPX900E supports S.GAIN (super gain) mode, featuring greater than 30-dB analog gain-up, together with DS.GAIN (digital super gain) mode, storage-type gain-up based on progressive drive technology.

To make use of this feature, you need to specify desired gains through the menu options S.GAIN and DS.GAIN.

For example, if the S.GAIN and DS.GAIN features are assigned to either the USER MAIN, USER1 or USER2 buttons, three different gain-up modes are available through button-mode combinations.

The menu options can be found in the <USER SW GAIN> screen, which is accessible from the CAM OPERATION page.

1) To increase the gain without increasing noise:

Combine the L/M/H gain and DS.GAIN features.

2) To increase the normal analog gain:

(noise is increased)

Use the S.GAIN feature alone.

3) To achieve ultra-high sensitivity:

Combine the S.GAIN and DS.GAIN features. (Gain increased by up to 68 dB.)

However, you should be extra careful when using this combination. With moving subjects, the greater the increase in DS.GAIN the more annoying the after-images will be.

In this case, limit the increase to +12dB ↑ (1/12).

Note that the DS.GAIN feature is disabled when the AJ-SPX900E is in progressive mode.

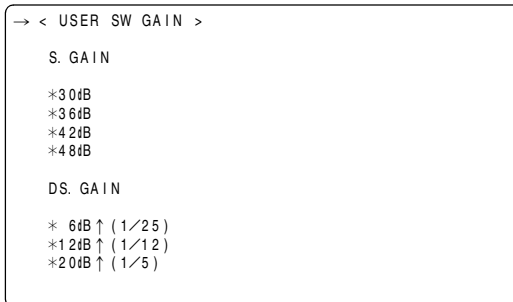

Settings Options and Usage

- S.GAIN:** Analog gain-ups with * marks enabled.
Analog gain-ups without * marks disabled.
- DS.GAIN:** Storage-type gain-ups with * marks enabled.
Storage-type gain-ups without * marks disabled.

4-9-2 Selecting Video Output Signals

You need to select the signals to be output from the VIDEO OUT and MON OUT connectors.

When the extension board AJ-YA902AG (optional accessory) is attached, an SDI signal can be output from the VIDEO OUT connector.

For more information, see [8-2-5 OUTPUT SEL].

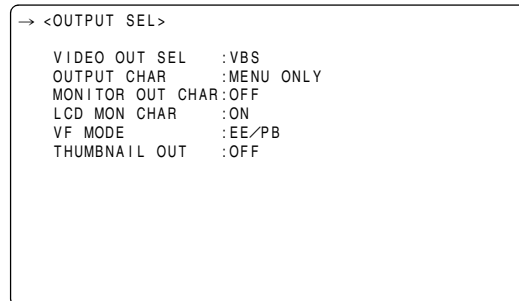

4-9-3 Selecting Function for the FRONT AUDIO LEVEL Control

The FRONT AUDIO LEVEL control can be assigned the function of adjusting the recording level.

To specify whether or not the FRONT AUDIO LEVEL control is effective on the channels set to accept input signals, use the menu options FRONT VR CH1 and FRONT VR CH2. These options can be found in the <MIC/AUDIO1> screen, which is accessible from the MAIN OPERATION page.

For more information, see [8-6-4 MIC/AUDIO1].

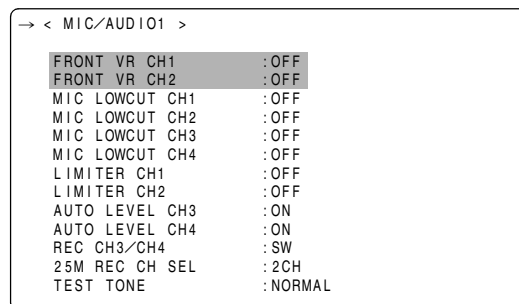

4-9-4 Assigning Functions to USER MAIN, USER1 and USER2 Buttons

The USER MAIN, USER1, and USER2 buttons can be assigned user-selected functions.

To select desired functions, use the menu options USER MAIN SW, USER1 SW and USER2 SW. These options can be found in the <USER SW> screen, which is accessible from the CAM OPERATION page.

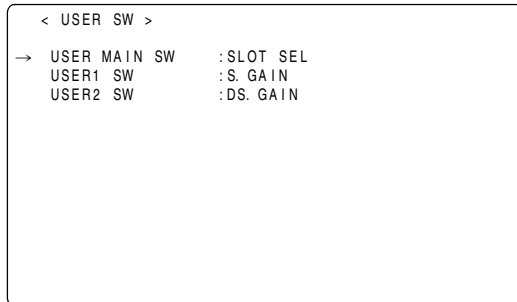

Selectable Functions

- INH:** No function assigned.
- S.GAIN:** S.GAIN function assigned.
- DS.GAIN:** DS.GAIN function assigned.
- S.IRIS:** Super Iris function assigned.
This is useful for backlight compensation.
- I.OVR:** Iris Override function assigned.
The target (reference) value in Auto Iris mode must be changed.
To change the target value, put the AJ-SPX900E into this mode and press the JOG dial button. Turn the JOG dial button clockwise or anti-clockwise to change the value. The iris indication section of the viewfinder screen displays “+”, “+ +”, “-”, or “- -”. When the desired value is displayed, stop turning the JOG dial button. Then, press the dial button to accept that value.
Note that once the mode is canceled or the power is turned off the original reference value will be used again.
 - + : Iris opens up by 0.5.
 - + + : Iris opens up by 1.
 - : Iris closes down by 0.5.
 - - : Iris closes down by 1.**No indication:** The reference value is used.
- S.BLK:** Super Black function assigned.
This function lowers the black level to the pedestal level or below.
- B.STR:** Black Stretch function assigned.
This function emphasises the black shades.
- D.ZOOM:** Doubles the view angle, both horizontally and vertically.
<Note>
When the camera is set to the 50i operation mode, this function forcibly switches the operation mode to 25P.
- ATW:** Auto-tracking white balance function assigned.
- Y GET:** Function of indicating the brightness level of the center marker assigned.

NEWS-G: Function of switching on and off News Gamma assigned.

<Note>

News Gamma is capable of reproducing shades without whiteout or blackout. This is useful for such operations as news shooting.

To turn on/off News Gamma using the USER button which is assigned NEWS-G, the menu option GAMMA MODE SEL must be set to “STD”. This option can be found in the <GAMMA> screen, which is accessible from the PAINT page.

AUDIO CH1: Function of switching the input signal source for Audio Channel 1 assigned.

Pressing the button switches the input signal in the following order: FRONT → W.L. → REAR. Note that the AUDIO IN switch can also be used to change the input signal: later specification takes precedence.

AUDIO CH2: Function of switching the input signal source for Audio Channel 2 assigned.

Pressing the button switches the input signal in the following order: FRONT → W.L. → REAR. Note that the AUDIO IN switch can also be used to change the input signal: later specification takes precedence.

REC SW: Function of the REC START/STOP button assigned.

RET SW: Function of the RET button at the lens assigned.

SLOT SEL: Function of switching the target P2 card among multiple cards assigned.

4-9-5 Setting Color Temperature Manually

The white balance can be manually adjusted by setting the color temperature. Manual color temperature settings can be performed for each of the WHITE BAL switch positions: PRST, A and B.

To enable manual color temperature setting, the menu options AWB A and AWB B must be set to VAR.

The color temperature is set using the menu options COLOR TEMP PRE, COLOR TEMP A, and COLOR TEMP B.

These options can be found in the <WHITE BALANCE MODE> screen, which is accessible from the CAM OPERATION page.

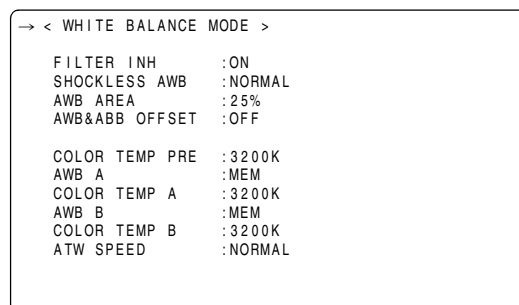

4-10 Handling data

Setting Data Using an SD memory card

An SD memory card (optional accessory) can be used as a setup card that stores up to eight files of settings menu specifications.

This data allows you to quickly reproduce an optimum state.

Regarding SD memory cards, please see <Cautions in using SD memory cards> (page 18).

4-10-1 Handling SD memory cards

An SD memory card may be inserted or removed, either before or after the power is turned on.

To insert an SD memory card

Open the lid of the switch cover, and insert an SD memory card (optional accessory) into the SD memory card slot with the notch upward. Close the lid.

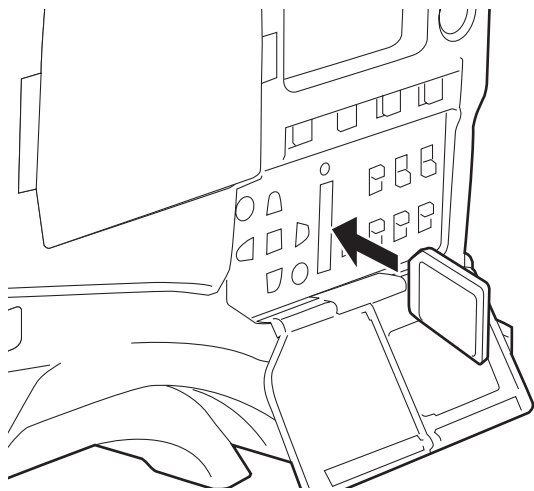

<Note>

An SD memory card must be inserted with the right side facing the slot. If the card is hard to insert, it may be reversed or upside down. Do not force it into the slot. Check the card before re-inserting it.

To remove the SD memory card

Open the lid of the switch cover, and ensure that the BUSY lamp is not illuminated. Then, further depress the SD memory card towards the main unit. This releases the SD memory card from the insertion slot. Take hold of the SD memory card and remove it. Close the lid.

SD memory cards must not be used or stored in an environment where they may be

- Exposed to high temperatures/humidities;
- Exposed to water droplets; or
- Electrically charged.

For storage, the SD memory card must be kept inserted into the AJ-SPX900E with the lid closed.

4-10-2 Formatting, Writing and Reading an SD memory card

To format an SD memory card, write settings data or read data on an SD memory card, navigate the menu to the <SD CARD READ/ WRITE> screen from the FILE page.

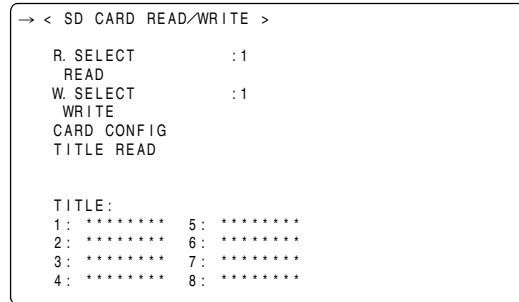

For an SD memory card formatted with a device that does not support SD standards, the message “FORMAT ERROR” appears at the upper right of the screen. In this case, reformat the card as follows. Note that the indication “FORMAT ERROR” does not disappear if the SD memory card is replaced with this menu page open. When the SD memory card is replaced, perform TITLE READ.

<Note>

It is not possible to read from or write to an SD memory card during INTERVAL REC mode operation by operating this menu. Perform the operation after stopping interval recording.

To format an SD memory card

<Note>

SD memory cards may be formatted via the thumbnail screen. For more information, see [6-15 Formatting SD memory cards].

- 1 Navigate the menu to the <SD CARD READ/WRITE> screen.
- 2 Turn the JOG dial button to move the cursor to the menu option CARD CONFIG.
- 3 Press the JOG dial button to display the following message:

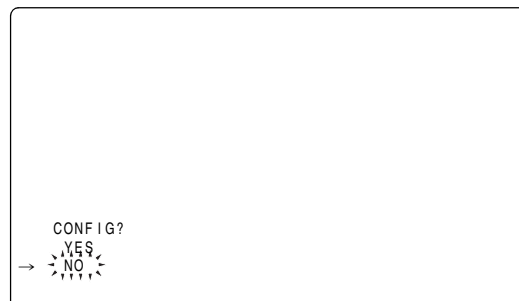

- 4** To format the SD memory card, turn the JOG dial button to move the cursor to YES. Then, press the dial button. When the SD memory card has been formatted, the following message appears:

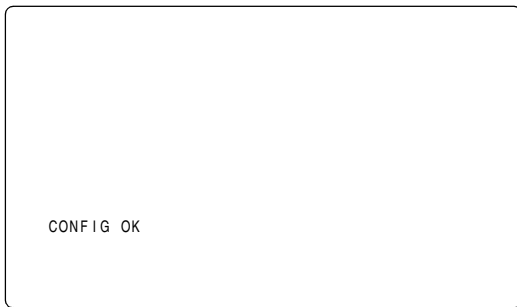

The card will not be formatted if the following message appears when the JOG dial button is pressed:

Error message	Remedy
CONFIG NG NO CARD (No SD memory card inserted.)	Insert an SD memory card.
CONFIG NG ERROR (SD memory card cannot be formatted.)	The card may be defective. Replace the card.
CONFIG NG WRITE PROTECT (SD memory card is write-protected.)	Remove the card and cancel the protect.
CONFIG NG CANNOT ACCESS (SD memory card not accessible).	Example: The SD memory card is not accessible because it is being played back. After the operation in process, format the card.

- 5** To exit the menu, press the MENU button. The settings menu disappears and the status of the AJ-SPX900E is indicated at the top and bottom of the viewfinder screen.

<Note>

If an SD memory card is inserted or removed with the <SD CARD READ/WRITE> screen open, the data title cannot be edited.

Move the cursor to the option TITLE READ and press the JOG dial button.
Edit the data title.

To write set data on an SD memory card

- 1** Navigate the menu to the <SD CARD READ/WRITE> screen.

To select a file number

- 2** Turn the JOG dial button to move the cursor to the option [W. SELECT]. Then, press the dial button.

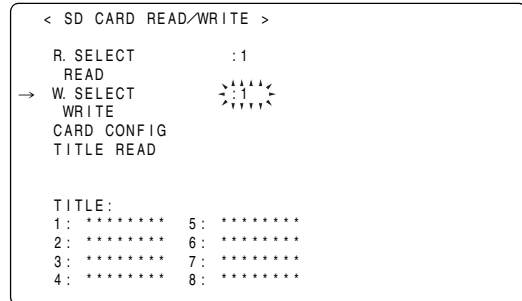

- 3** Turn the JOG dial button to select a desired number (1 - 8). Then, press the dial button.

To give the selected file a title

- 4** Turn the JOG dial button to move the cursor to the option [TITLE:].

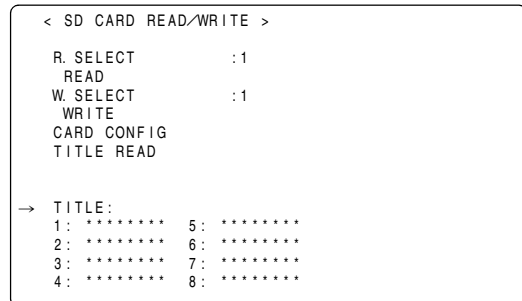

- 5** Press the JOG dial button. This moves the cursor to the entry area, putting the AJ-SPX900E in entry mode.

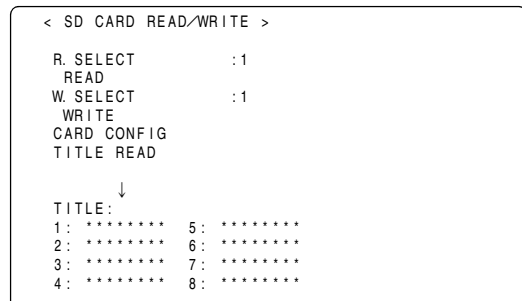

6 Turn the JOG dial button until a desired character appears. The characters that appear are switched in the following order:

- Space: □
- ↓
- Alphabetical characters: A to Z
- ↓
- Numerals: 0 to 9
- ↓
- Symbols: ', >, <, /, -

7 Press the JOG dial button to accept a desired character.

8 Turn the JOG dial button to move the cursor to the next digit (clockwise), and repeat Steps 6 - 7 to set characters (up to eight characters).

To write data on a selected file

9 When the title is set, turn the JOG dial button to move the cursor to [:].

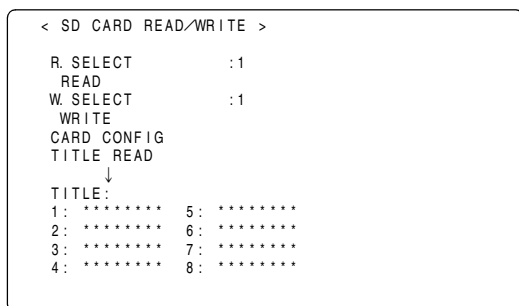

10 Press the JOG dial button to return the cursor to the option [TITLE:].

11 Turn the JOG dial button to move the cursor to the option [WRITE].

12 Press the JOG dial button to display the following message:

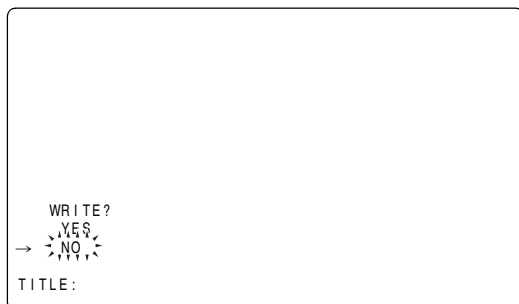

The data will not be written if any of the following messages appears when the JOG dial button is pressed:

Error message	Remedy
WRITE NG NO CARD (No SD memory card inserted.)	Insert an SD memory card.
WRITE NG FORMAT ERROR (SD memory card not properly formatted.)	The card has not been formatted using the AJ-SPX900E. Replace the card.
WRITE NG ERROR (SD memory card not writable.)	The card may be defective. Replace the card.
WRITE NG WRITE PROTECT (SD memory card write-protected.)	Remove the card and disable the protect.
WRITE NG CANNOT ACCCESS (SD memory card not accessible).	Example: The SD memory card is not accessible because it is being played back. After the operation in process, format the card.
WRITENG CARD FULL (SD memory card has no free space.)	The card is not writable because it has no free space. Delete unwanted files or replace the card with a new one.

13 Turn the JOG dial button to move the cursor to YES. Then, press the dial button. When the data has been written, the following message appears:

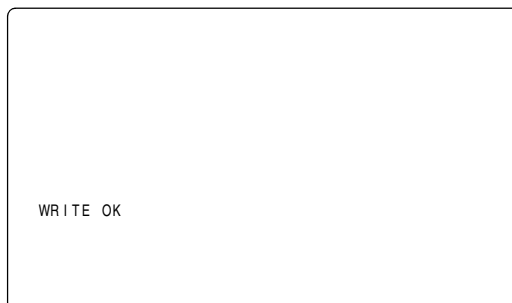

14 To exit the menu, press the MENU button. The settings menu disappears and the status of the AJ-SPX900E is indicated at the top and bottom of the viewfinder screen.

To read data on an SD memory card

- 1 Turn the JOG dial button to move the cursor to the option [SD CARD READ/WRITE]. Then, press the dial button.

To select a file number

- 2 Turn the JOG dial button to move the cursor to the menu option [R. SELECT]. Then, press the dial button.

```

< SD CARD READ/WRITE >
→ R. SELECT          1
  READ
  W. SELECT          1
  WRITE
  CARD CONFIG
  TITLE READ

TITLE:
1: ***** 5: *****
2: ***** 6: *****
3: ***** 7: *****
4: ***** 8: *****
    
```

- 3 Turn the JOG dial button to select a desired number (1 - 8). Then, press the dial button.

To read data on a selected file

- 4 Turn the JOG dial button to move the cursor to the option [READ].

```

< SD CARD READ/WRITE >
  R. SELECT          :1
→  READ
  W. SELECT          :1
  WRITE
  CARD CONFIG
  TITLE READ

TITLE:
1: ***** 5: *****
2: ***** 6: *****
3: ***** 7: *****
4: ***** 8: *****
    
```

- 5 Press the JOG dial button to display the following message:

```

READ?
  YES
→ NO
    
```

- 6 Turn the JOG dial button to move the cursor to YES. Then, press the dial button. When the data has been read, the following message appears:

```

READ OK
    
```

The data will not be read if any of the following messages appears when the JOG dial button is pressed:

Error message	Remedy
READ NG NO CARD (No SD memory card inserted.)	Insert an SD memory card.
READ NG FORMAT ERROR (SD memory card not properly formatted.)	The card has not been formatted using the AJ-SPX900E. Replace the card.
READ NG NO FILE (No file found.)	Write file data.
READ NG ERROR (SD memory card not readable.)	Only data written with the AJ-SPX900E is readable.
READ NG CANNOT ACCESS (SD memory card not accessible).	Example: The SD memory card is not accessible because it is being played back. After the operation in process, read data.

- 7 To exit the menu, press the MENU button. The settings menu will be replaced by status indications for the AJ-SPX900E.

4-10-3 How to Use the User Data

It is possible to transfer settings and other data to the user area of the internal memory of the AJ-SPX900E.

This data allows you to quickly reproduce an optimum setup state.

To write data, go to the <INITIALIZE> screen from the FILE page. To read the written user data, go to the <SCENE> screen from the FILE page.

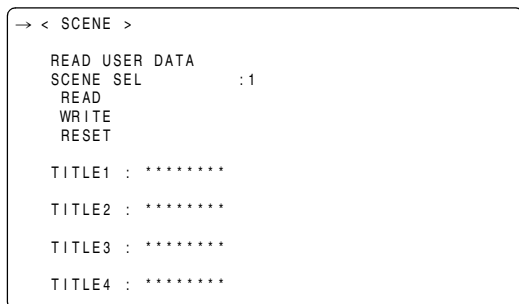
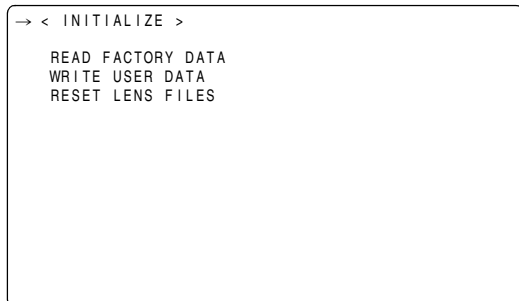

To write settings data in the user area

- 1 Navigate the menu to the <INITIALIZE> screen.
- 2 Turn the JOG dial button to move the cursor to the option WRITE USER DATA.

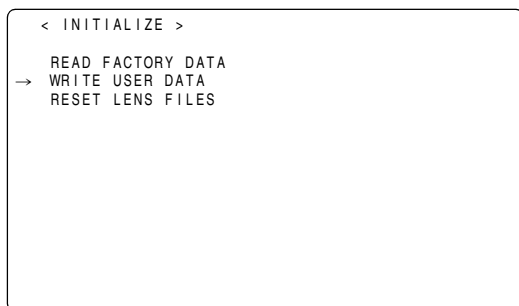

- 3 Press the JOG dial button to display the following message:

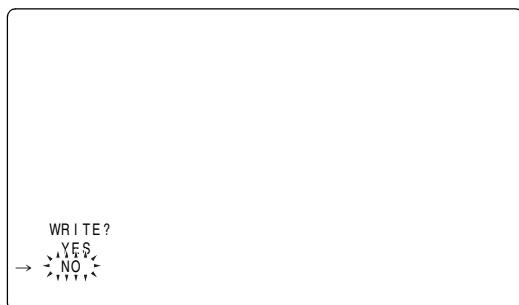

- 4 Turn the JOG dial button to move the cursor to YES. Then, press the dial button. This writes the settings data into the user area of the internal memory of the AJ-SPX900E.
- 5 To exit the menu, press the MENU button.

To read written user data

- 1 Navigate the menu to the <SCENE> screen.
- 2 Turn the JOG dial button to move the cursor to the option READ USER DATA.
- 3 Press the JOG dial button to display the following message:



- 4 Turn the JOG dial button to move the cursor to YES. Then, press the dial button. The data written in the user area of the internal memory of the AJ-SPX900E is read to complete the setting.
- 5 To exit the menu, press the MENU button.

The set user data may be also read without navigating the menu.

- 1 Turn off the POWER switch.
- 2 Position the WHITE BAL switch at [PRST].

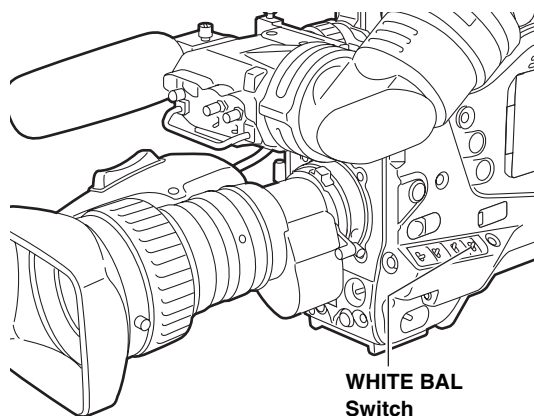

- 3 With the AUTO W/B BAL switch flipped up, turn on the POWER switch. This resets all settings for USER menu options to their defaults.

4-10-4 How to Use Scene File Data

It is possible to write the settings data into the scene file area of the internal memory of the AJ-SPX900E, or to read data written in this area. Four types of scene files are available. This data allows you to quickly reproduce an optimum setup state. TITLES 1 - 3 are factory-assigned the defaults for the AJ-SPX900E; TITLE 4 is assigned the parameter for FILMLIKE. The setting for TITLE 4 can be changed.

To change the settings, go to the <SCENE> screen from the FILE page.

To write settings data for scene files

- 1 Navigate the menu to the SCENE screen.
- 2 Turn the JOG dial button to move the cursor to the SCENE SEL option.
- 3 Press the JOG dial button to blink scene file numbers. Then, turn the dial button to select a desired scene file number.

```
< SCENE >
  READ USER DATA
  → SCENE SEL      :1
    READ
    WRITE
    RESET

  TITLE1 : *****
  TITLE2 : *****
  TITLE3 : *****
  TITLE4 : *****
```

- 4 Press the JOG dial button to accept the scene file.
- 5 Turn the JOG dial button to return the cursor to the option WRITE.

```
< SCENE >
  READ USER DATA
  SCENE SEL      :1
  → READ
  WRITE
  RESET

  TITLE1 : *****
  TITLE2 : *****
  TITLE3 : *****
  TITLE4 : *****
```

- 6 Press the JOG dial button to display the following message:

```
WRITE?
  YES
  → NO
  YES
  TITLE:
```

- 7 Turn the JOG dial button to move the cursor to YES. Then, press the dial button. This writes the setting data into the scene file area of the AJ-SPX900E internal memory.
- 8 To exit the menu, press the MENU button.

To read settings data for scene files

- 1 Navigate the menu to the <SCENE> screen.
- 2 Turn the JOG dial button to move the cursor to the option SCENE SEL.
- 3 Press the JOG dial button to blink scene file numbers. Then, turn the dial button to select a desired scene file number.

```
< SCENE >
READ USER DATA
→ SCENE SEL      :1
  READ
  WRITE
  RESET

TITLE1 : *****
TITLE2 : *****
TITLE3 : *****
TITLE4 : *****
```

- 4 Press the JOG dial button to accept the scene file.
- 5 Turn the JOG dial button to move the cursor to the READ option.

```
< SCENE >
READ USER DATA
SCENE SEL      :1
→ READ
  WRITE
  RESET

TITLE1 : *****
TITLE2 : *****
TITLE3 : *****
TITLE4 : *****
```

- 6 Press the JOG dial button to display the following message:

```
READ?
YES
→ NO
```

- 7 Turn the JOG dial button to move the cursor to YES. Then, press the dial button.
The data stored in the scene file area of the internal memory of the AJ-SPX900E is read to complete the setting.
- 8 To exit the menu, press the MENU button.

To return data for scene files to their defaults

- 1 Navigate the menu to the <SCENE> screen.
- 2 Turn the JOG dial button to move the cursor to the option SCENE SEL.
- 3 Press the JOG dial button to blink scene file numbers. Then, turn the dial button to select the scene file that you want to reset.

```
< SCENE >
READ USER DATA
→ SCENE SEL      :1
  READ
  WRITE
  RESET

TITLE1 : *****
TITLE2 : *****
TITLE3 : *****
TITLE4 : *****
```

- 4 Press the JOG dial button to accept the scene file.
- 5 Turn the JOG dial button to move the cursor to the option [RESET].

```
< SCENE >
READ USER DATA
SCENE SEL      :1
  READ
  WRITE
→ RESET

TITLE1 : *****
TITLE2 : *****
TITLE3 : *****
TITLE4 : *****
```

- 6 Press the JOG dial button to display the following message:

```
RESET?
YES
→ NO
```

- 7 Turn the JOG dial button to move the cursor to YES. Then, press the dial button.
The data stored in the scene file area of the internal memory of the AJ-SPX900E is reset to the defaults.
- 8 To exit the menu, press the MENU button.

To title settings data for scene files

- 1 Navigate the menu to the <SCENE> screen.
- 2 Turn the JOG dial button to move the cursor to the option [TITLES 1 - 4] for the appropriate scene file.

```
< SCENE >
READ USER DATA
SCENE SEL      :1
READ
WRITE
RESET
→ TITLE1 : *****
TITLE2 : *****
TITLE3 : *****
TITLE4 : *****
```

- 3 Press the JOG dial button to move the cursor to the title entry area, putting the AJ-SPX900E in entry mode.

```
< SCENE >
READ USER DATA
SCENE SEL      :1
READ
WRITE
RESET
↓
TITLE1 : *****
TITLE2 : *****
TITLE3 : *****
TITLE4 : *****
```

- 4 Turn the JOG dial button until a desired character appears. The characters that appear are switched in the following order:

Space:

↓

Alphabetical characters: A to Z

↓

Numerals: 0 to 9

↓

Symbols: ', >, <, /, -

- 5 Press the JOG dial button to accept a desired character.
- 6 Turn the JOG dial button to move the cursor to the next digit (clockwise), and repeat Steps 4 - 5 to set characters (up to eight characters).
- 7 When the title is set, turn the JOG dial button to move the cursor to [:].
- 8 Press the JOG dial button to return the cursor to the options TITLES 1 - 4.
- 9 Turn the JOG dial button to return the cursor to the option WRITE.

- 10 Press the JOG dial button to display the following message:

```
WRITE?
YES
→ NO
←
TITLE:
```

- 11 Turn the JOG dial button to move the cursor to YES. Then, press the dial button.

This writes the title into the scene file area of the AJ-SPX900E internal memory.

- 12 To exit the menu, press the MENU button.

4-10-5 Resetting Menu Option Settings to Defaults

The menu settings can be reset to their defaults.

To reset the settings to their defaults, select the menu option READ FACTORY DATA in the <INITIALIZE> screen, which is accessible from the FILE page.

All settings will be reset to their defaults.

```
< INITIALIZE >
→ READ FACTORY DATA
WRITE USER DATA
RESET LENS FILES
```

<Note>

This operation does not delete the scene file, lens file, and the information stored as the user data.

4-10-6 Lens File Data

The AJ-SPX900E is capable of correcting the lens white shading. This lens white shading correction may be stored as lens file data (maximum number of data sets is eight). Lens file data allows you to quickly perform a proper white shading adjustment, even when the lens is replaced.

For more information on reading/writing data, see [5-3 Mounting the lens and Performing the Flange Back and White Shading Adjustments].

Chapter 5 Preparation

5-1 Power Supply

A battery pack or AC power can be used as the power supply for the camera-recorder.

Using a Battery Pack

Battery packs from the following manufacturers can be used:

- Panasonic
- Anton/Bauer
- IDX
- PACO
- Sony

<Notes>

- Other batteries may be used by changing the menu setting, but system compatibility is not guaranteed.
- Charge the battery pack with the battery charger before using it. (Please refer to the battery charger's instruction manual for information about charging.)

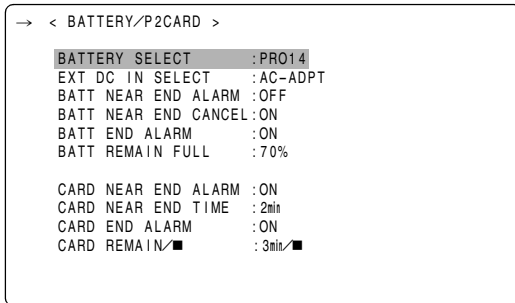

5-1-1 Mounting the battery and setting the battery type

Using an Anton/Bauer Battery Pack

- 1 Mount the Anton/Bauer battery pack.

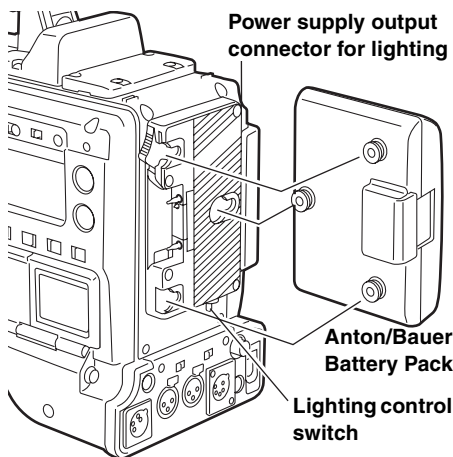

<For your information>

The Anton/Bauer battery holder includes both a power supply output connector for lighting and a lighting control switch, which are convenient when attaching a light. Please contact Anton/Bauer for information about the lighting system.

- 2 Insert the battery and slide it in the direction of the arrow.

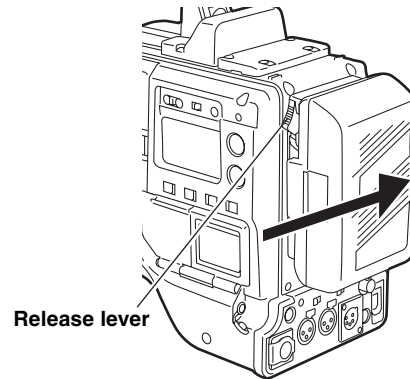

<For your information>

Removing the battery pack

Completely push down and hold the release lever on the battery holder. Then, slide the battery pack in the opposite direction to the arrow while holding the lever down.

- 3 Setting the battery type.
Select the battery type listed under BATTERY SELECT. Select BATTERY SELECT from the <BATTERY/P2CARD> screen in the MAIN OPERATION page. Please refer to [8-6-2 BATTERY SETTING1] for more information.

The following Anton/Bauer batteries can be used:

- PRO14
- TRIM14
- HYTRON50
- HYTRON100
- HYTRON120
- DIONIC90
- DIONIC160

<Note>

To use DIONIC, please set it as DIONIC90.

When using a BP-90 type battery pack

- 1 Remove the battery holder.

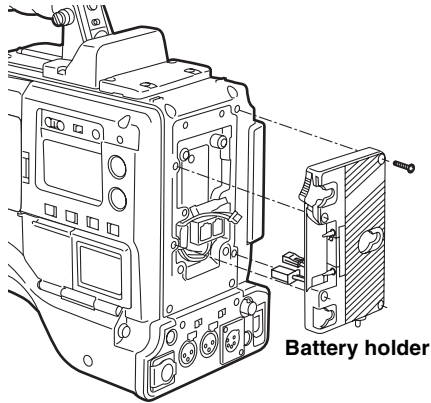

- 2 Attaching the battery case to the camera-recorder.
 - ① Connect the cable on the camera-recorder to the cable on the battery case (BP-90 type).
 - ② Using a screwdriver, secure the battery case (BP-90 type) to the camera-recorder.
Open the cover and lift the rubber cap so that the screw tightening hole is visible. Tighten the screws to secure the battery case to the camera-recorder. Be sure to fully tighten the screws.

<Notes>

- Do not use excess force when lifting the rubber caps forcibly.
- Take special care not to pinch the cable.

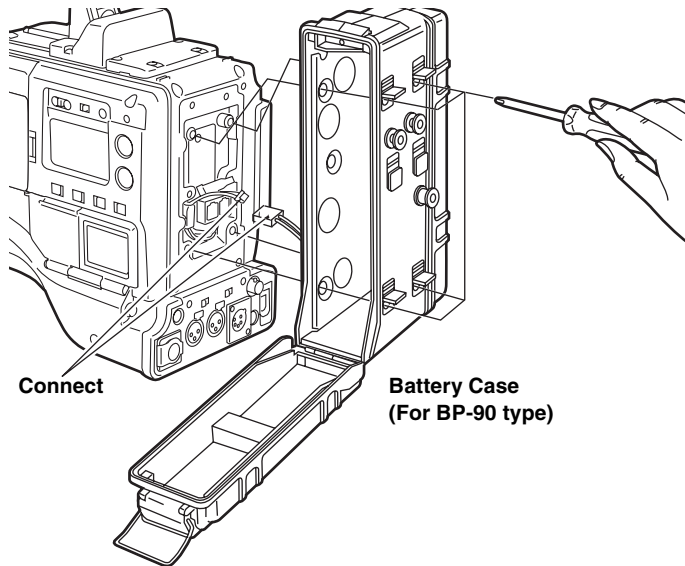

- 3 Connect the battery pack plug to the socket inside the battery case, and insert the battery pack into the case.

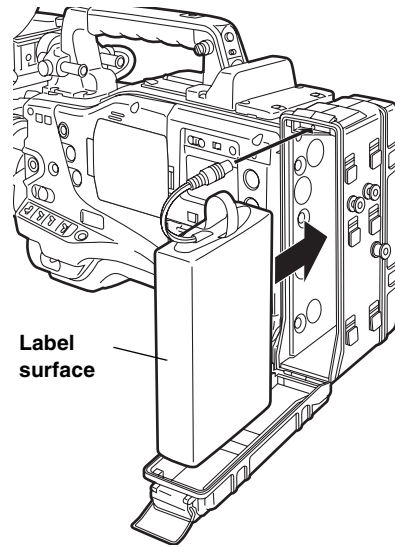

<Note>

Make sure you turn OFF the camera-recorder power before connecting or disconnecting the plug.

- 4 Setting the battery type.
Select the battery type listed under BATTERY SELECT. Select BATTERY SELECT from the <BATTERY/P2CARD> screen on the MAIN OPERATION page. Please refer to [8-6-2 BATTERY SETTING1] for more information.

Using an NP-1 type battery pack

- 1 Remove the battery holder.
- 2 Mount the NP-1 type battery case on the camera-recorder.
 - ① Tighten the mounting screws.
 - ② Tighten the power contact screws.
 - ③ Insert the upper part of the removed cover in the direction of the arrow.
 - ④ Align the holes in the bottom part (metal part) of the cover with the holes in the case, and secure the cover with the screw.

<Note>

When mounting the battery holder, take care not to pinch the connection cord.

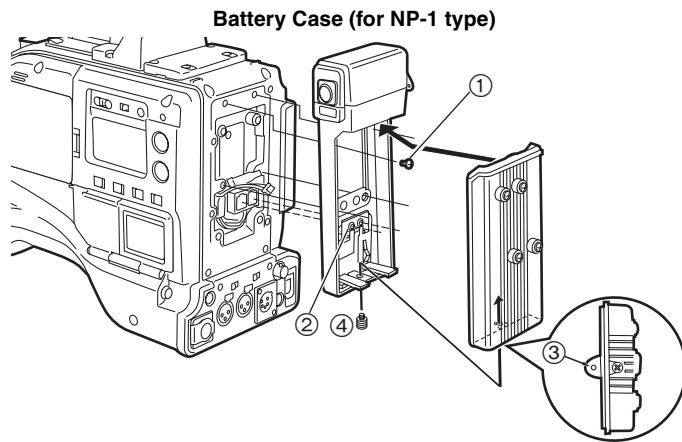

When using a V-mount type battery pack

Mount the V-mount adapter plate.
Insert the plate and slide it in the direction of the arrow.

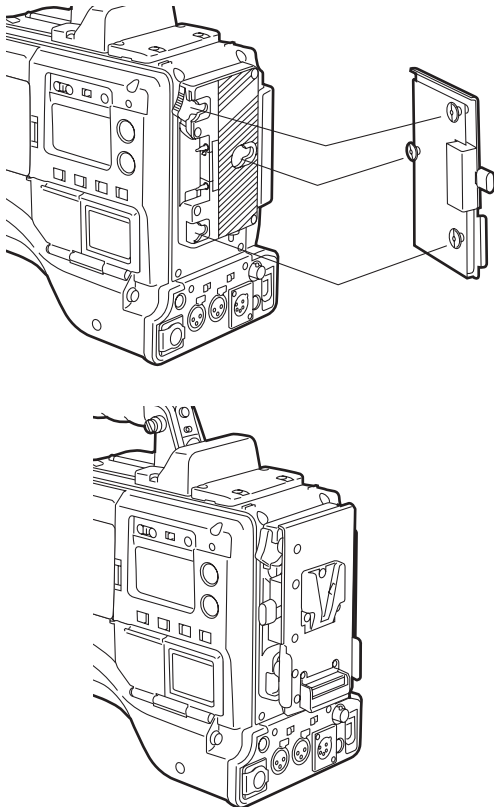

- 3 Setting the battery type.
Select the battery type listed under BATTERY SELECT. Select BATTERY SELECT from the <BATTERY/P2CARD> screen on the MAIN OPERATION page.
When using a battery not listed under BATTERY SELECT: If it is a NiCd battery, select "NiCd14(14V)", "NiCd13(13V)", or "NiCd12(12V)", depending on the battery voltage. Set the other items according to the battery properties. If it is not a NiCd battery, select TYPE A or TYPE B and set the other items according to the battery properties. Please refer to [8-6-3 BATTERY SETTING2] for more information.

<Note>

For information about the V-mount adapter plate, please contact the store where you purchased the camera-recorder.

5-1-2 Using an AC Power Supply

When using the Panasonic AJ-B75 AC adapter

- 1 Plug the AJ-B75 DC OUT connector into the camera-recorder's external DC input socket.

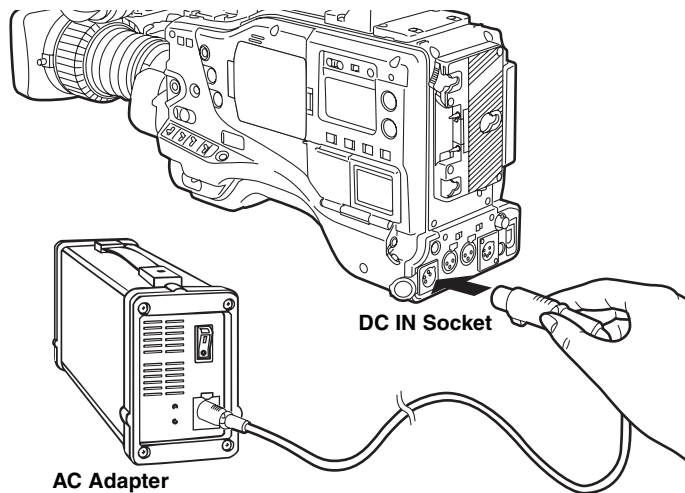

AC Adapter

- AJ-B75 (Optional)

- 2 Turn the AC adapter power ON.
- 3 Turn the camera-recorder power switch ON.

When using an external power supply other than the AC adapter AJ-B75, check the DC IN socket pin information to ensure correct polarity. If a +12V power supply is accidentally connected to the GND terminal, this could cause a fire or personal injury.

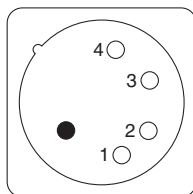

DC IN Socket

Pin No.	Signal
1	GND
2, 3	—
4	+12V

<Notes>

- When both the battery pack and AC adapter are connected, power is supplied from the AC adapter. The battery can be removed or mounted while using the AC adapter.
- When using the AC adapter, make sure you turn ON the AC adapter power before turning ON the camera-recorder's power switch. If this sequence is reversed, the camera-recorder may malfunction due to slow rising of the AC adapter output voltage.
- When connecting a battery to the DC IN socket, select the battery type listed under EXT DC IN SELECT. Select EXT DC IN SELECT from the <BATTERY/P2CARD> screen on the MAIN OPERATION page. In this case, however, the % display is disabled, even when using a digital battery.

5-2 Mounting the Viewfinder and Adjusting its Position

Please refer to the viewfinder instruction manual.

Note: A slide rail is required to mount any viewfinder other than models AJ-VF15B or AJ-VF20WB.

- If you need to buy a slide rail, please contact the store where you purchased the camera-recorder and tell them that the slide rail is a "repair part".

Slide rail (VFC3995)

Screws (XBS3+8VZ)

Mounting the Slide Rail

- 1 Undo the upper two screws for AJ-VF15 or AJ-VF20W, and remove the mounting unit. Leave the screws attached to the mounting unit.

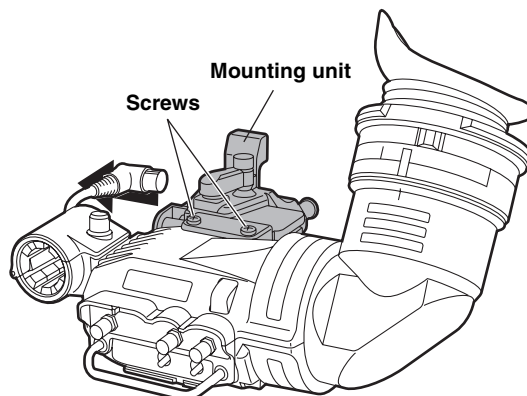

- 2 Mount the slide rail, then tighten the two screws.

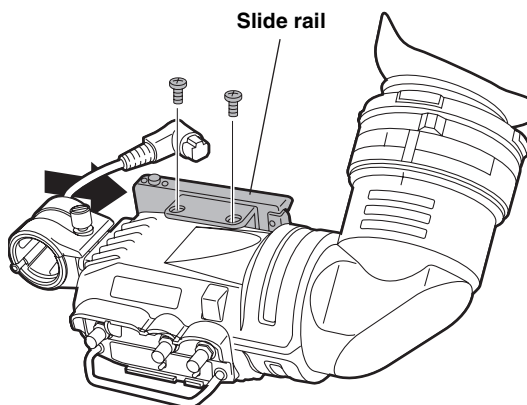

5-3 Mounting the lens and Performing the Flange Back and White Shading Adjustments

Mounting the Lens

- 1 Raise the lens clamping lever and remove the mount cap.

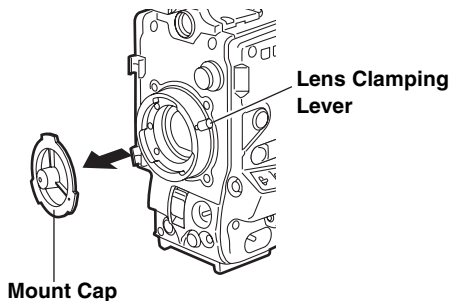

- 2 To mount the lens, align the indentation at the top center of the lens mount with the center mark of the lens.

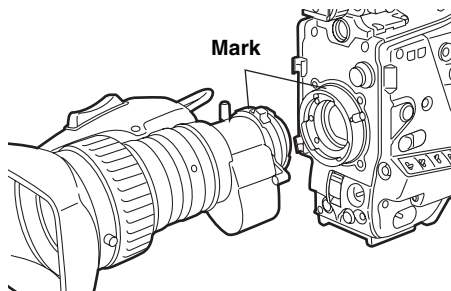

- 3 Lower the lens clamping lever to clamp the lens.

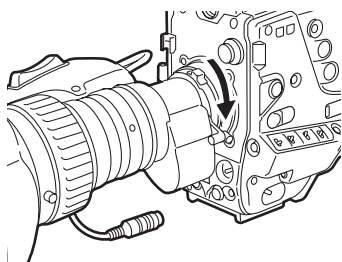

- 4 Secure the cable through the cable clamp, and plug it into the LENS connector.

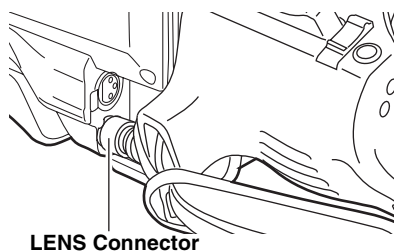

- 5 Adjust the lens flange back.

<Notes>

- Please refer to the lens instruction manual for guidance on lens handling.
- When the lens is removed, install the mount cap to protect the device.

Adjusting the Lens Flange Back

If images are not clearly focused at both telephoto and wide-angle positions during zoom operations, adjust the flange back (distance from the lens mounting surface to the image formation surface).

Once adjusted, the flange back does not need to be re-adjusted as long as the same lens is mounted on the camera.

<Note>

Please also refer to the lens instruction manual for directions on adjustment and locations of individual lens parts.

- 1 Mount the lens on the camera.
Make sure you connect the lens cable.
- 2 Set the lens iris to manual, and fully open the iris.

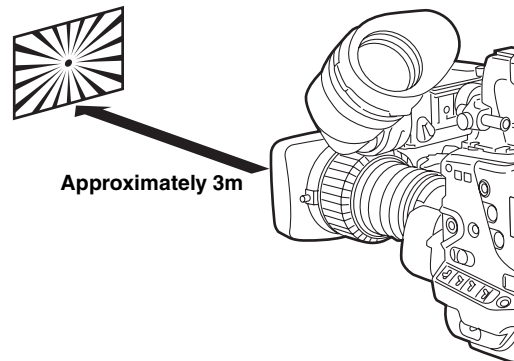

- 3 Place the flange back adjustment chart about 3 m from the lens and adjust the lighting on the chart to obtain an appropriate video output level.
If the video level is too high, use the filters or the shutter.

- 4 Loosen the F.f (Flange focus) ring clamping screw.

<Note>

F.b (Flange back) may be indicated on some lenses.

- 5 Set the zoom ring to the telephoto position, either manually or by electric drive.

- 6 Aim the lens at the flange back adjustment chart and turn the distance ring to bring the chart into focus.

- 7 Set the zoom ring to the wide-angle position and turn the F.f ring to bring the chart into focus.
While focusing, take care not to move the distance ring.

- 8 Repeat Steps 5 to 7 until the lens is in focus at both the telephoto and wide-angle positions.

- 9 Firmly tighten the F.f ring clamping screw.

Adjusting the Lens White Shading

Take the following steps to adjust the white shading:

<Note>

Vertical coloring may occur near the open position of the lens iris, even after adjusting the white shading. This phenomenon, however, is a characteristic of the lens or optical system. It does not indicate a malfunction.

- 1 Mount the lens on the camera.
Be sure to connect the lens cable.
- 2 Set the electronic shutter to [OFF], the gain to [L (0dB)], and the ASPECT option to "16:9". Select the ASPECT option from the SYSTEM MODE screen on the SYSTEM SETTING page.
- 3 If the lens has an extender, disable the extender feature.
- 4 Operate the MENU and go to the PAINT page to open the <GAMMA> screen. Confirm that the GAMMA MODE SEL is set to STD. From the VF page, open the <VF DISPLAY> screen to confirm that ZEBRA1 DETECT, ZEBRA2 DETECT, and ZEBRA2 are set as shown in the diagram below. If they are not, correct the settings and then close the MENU screen.

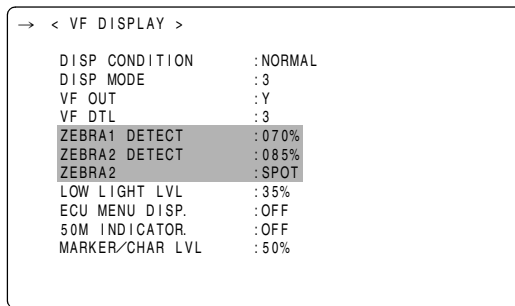

- 5 Set the Viewfinder ZEBRA switch to ON.
- 6 Aim the lens at a sheet of white paper that has no color shading.

<Note>

Flickering naturally occurs when fluorescent, mercury or other such lamps are used for lighting. Therefore, use a light source that does not flicker, such as sunlight or halogen lamps.

- 7 Set the lens iris to manual and adjust the lens iris so that the ZEBRA pattern covers the entire screen.
Make sure that the lens iris is set between F4 and F11.

<Notes>

- The ZEBRA pattern will not cover the entire screen if the lighting is uneven. In this case, adjust the lighting (e.g., change the position of the light source).
- Even if the lens iris is not set between F4 and F11, adjust the lighting (e.g., change the position of the light source).
- Make sure that the electronic shutter is set to OFF.

- 8
 - ① Set the WHITE BAL selector switch to A or B, and execute Auto White Balance (AWB) with the AUTO W/B BAL switch.
 - ② Next, execute Auto Black Balance (ABB) with the AUTO W/B BAL switch.
 - ③ Repeat Auto White Balance (ABB) with the AUTO W/B BAL switch.
- 9 Repeat the adjustment described in Step 7.
- 10 Activate the MENU and go to the MAINTENANCE page to open the <WHITE SHADING> screen.
- 11 Turn the JOG Dial button to move the cursor to DETECTION (V.SAW). Then, press the JOG Dial button to execute white shading compensation.

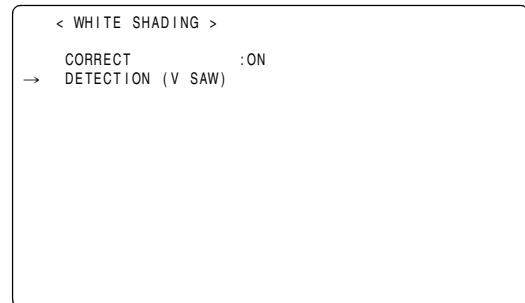

- 12 Press the JOG Dial button and the following message appears.



- 13 Turn the JOG Dial button to move the cursor to [YES]. Then press the JOG Dial button.
[ACTIVE] appears on the screen to indicate that the white shading automatic adjustment is running.
[W-SHD OK] appears when the adjustment is completed.

<Note>

This compensation may not be possible when [LEVEL OVER] is displayed, depending on the KNEE setting. In this case, first narrow the lens iris or set the OUTPUT switch AUTO KNEE to OFF. Next, activate the MENU to open the PAINT screen. From the PAINT screen, open the <KNEE/LEVEL> screen and set MANUAL KNEE to OFF. Then repeat Steps 4 to 9.
After [W-SHD OK] is displayed, re-set MANUAL KNEE back to ON.

- 14 If the lens has an extender or a ratio converter, enable the feature and repeat Steps 7 to 13 for each feature.
Three patterns of compensation values (with an extender, with a ratio converter, and without any features) will be stored as one set of lens file data in the camera-recorder.

This completes the white shading adjustment. The compensation values are stored in the non-volatile internal memory. Therefore, re-adjusting the white shading is not required, even after the camera-recorder power has been turned off.

Storing the Lens File Data

The white shading compensation values can be stored in the internal memory as lens file data.

Selecting the File number

- 1** Activate the MENU and go to the FILE page to open the <LENS> screen. Turn the JOG Dial to move the cursor to the item FILE NO.
- 2** Press the JOG Dial button and FILE NO. will start blinking. Turn the JOG Dial button to select the desired lens file (1-8) to be stored.

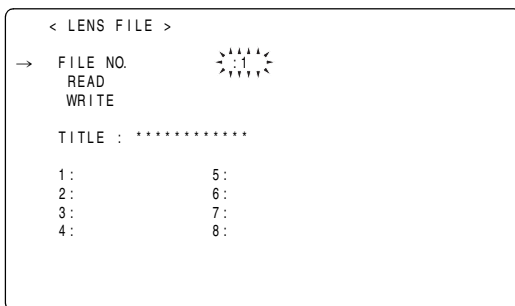

- 3** Press the JOG Dial button to confirm the lens file.

Adding a Title to the Selected File No.

- 4** Turn the JOG Dial button to move the cursor to [TITLE:].

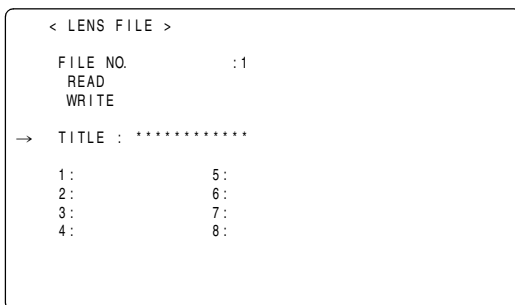

- 5** Press the JOG Dial button. The cursor moves to the title input field, and input mode is enabled.

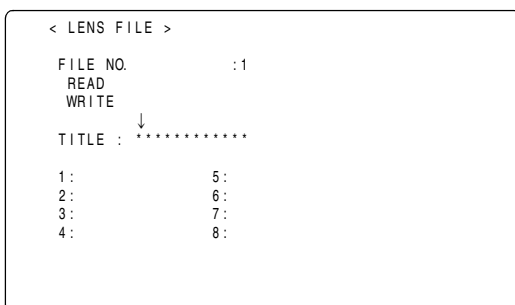

- 6** Press the JOG Dial button again and turn it until a desired letter for the title appears. Turning the JOG Dial button changes the letter displayed in the following sequence:

Space: □
 ↓
 Alphabetical characters: A to Z
 ↓
 Numerals: 0 to 9
 ↓
 Symbols: ', >, <, /, -

- 7** Press the JOG Dial button to confirm the letter.
- 8** Turn the JOG Dial button to move the cursor to the next position (to the right), and repeat Steps 6 to 7 to set the letters for the title. (Up to 12 letters)
- 9** When the title input is completed, turn the JOG Dial button to move the cursor to the [:] position.

- 10** Press the JOG Dial button. The cursor returns to [TITLE:].

- 11** Turn the JOG Dial button to move the cursor to [WRITE:].

- 12** Press the JOG Dial button and the following message appears.

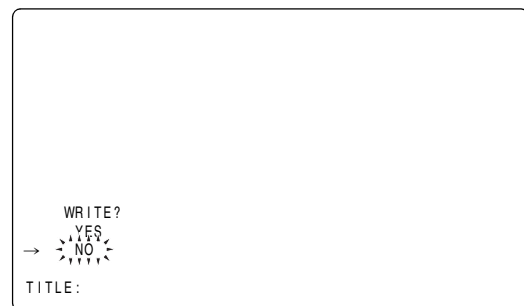

- 13** Turn the JOG Dial button to move the cursor to [YES]. Then, press the JOG Dial button.

[WRITE OK] will appear after writing is completed, indicating that the set data and the title have been stored in the lens file area of the camera's internal memory.

- 14** Press the MENU button to exit the menu operation.

Reading out the Lens File Data

- 1 Select the lens file No. to read out by following Steps 1 to 3 in the [Storing the Lens File Data] section.
- 2 Turn the JOG Dial button to move the cursor to [READ:].
- 3 Press the JOG Dial button and the following message appears.



- 4 Turn the JOG Dial button to move the cursor to [YES]. Then, press the JOG Dial button. [READ OK] will be displayed after the stored lens file data has been read out.
- 5 Press the MENU button to exit the menu operation.

Resetting Lens File Data to Factory Standard Settings

The lens file data can be reset to the standard setting values that were set when the camera was shipped from the factory. From the FILE page, open the <INITIALISE> screen.

- 1 From the INITIALIZE screen, select [RESET LENS FILES].

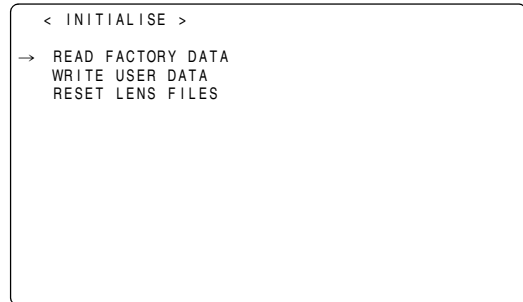

- 2 When the JOG Dial button is pressed, the message shown below appears.

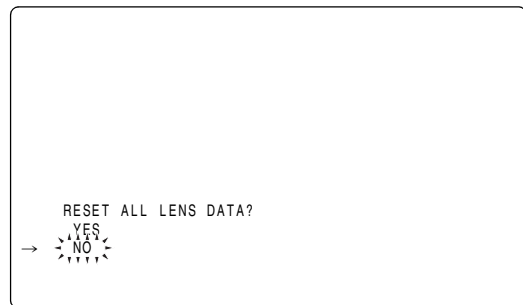

- 3 Turn the JOG Dial button to move the cursor to [YES], then press the JOG Dial button. [OK] is displayed, resetting the lens file data to the factory default values.

5-4 Preparing for Audio Input

Take the following steps to prepare the camera for connecting audio input devices.

5-4-1 When Using the Front Microphone

The AJ-MC700P microphone kit (optional) includes a microphone that can be mounted on the camera.

- 1 Open the microphone holder.

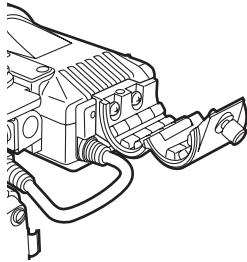

- 2 Mount the microphone and tighten the clamping screw.

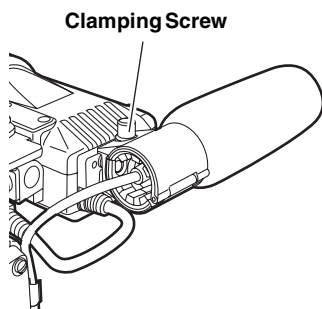

- 3 Connect the microphone cable to the MIC IN jack on the camera.

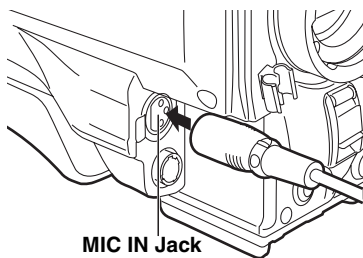

- 4 Set the AUDIO IN switch to [FRONT] depending on the audio channel to be recorded.

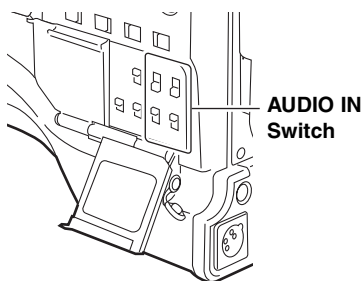

5-4-2 When Using a Wireless Receiver

Using an External Wireless Receiver

Mount a wireless receiver when using a wireless system.

- 1 Mount the wireless receiver on the camera attachment.
- 2 Align the grooves in the camera attachment with the pins on the unit (e.g., the battery case), and mount the wireless receiver.

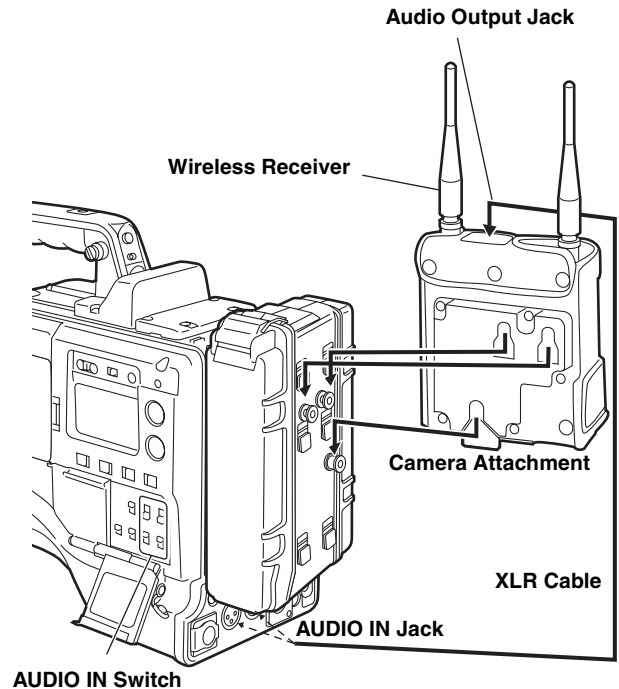

- 3 Connect the wireless receiver to the AUDIO IN jack with the XLR cable.
- 4 Set the AUDIO IN switch to [REAR] for the channel to which the XLR cable is connected.
- 5 Set the LINE/MIC/+48V selector switch on the rear panel to [MIC].
To remove the wireless receiver, raise the lever on the bottom of the camera attachment.

<Note>

Please refer to the wireless receiver's instruction manual for such information as operation of the wireless receiver.

When Using the Unislot Wireless Receiver

- 1 Remove the cover to insert the wireless receiver and secure it with the screws.

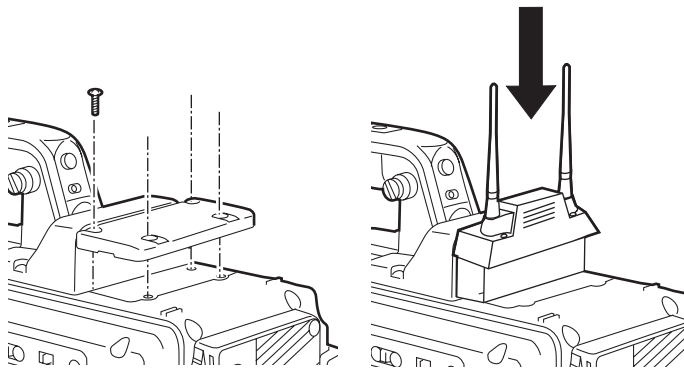

- 2 Set the AUDIO IN switch to [W.L.] depending on the audio channel to be recorded.

5-4-3 When Using Audio Devices

- 1 Connect the audio device to the AUDIO IN jack with the XLR cable.
- 2 Set the AUDIO IN switch to [REAR] for the channel to which the XLR cable is connected.
- 3 Set the LINE/MIC/+48V selector switch on the rear panel to [LINE].

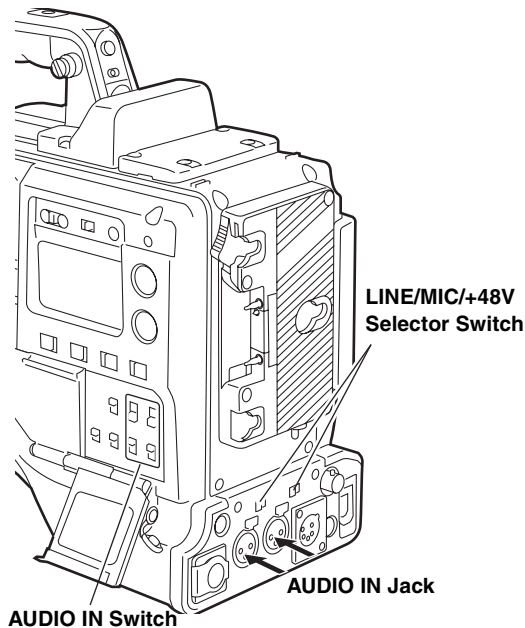

5-5 Connection between the USB 2.0 port of the AJ-SPX900E and a PC

By connecting the AJ-SPX900E with an external PC using USB 2.0, the P2 card connected to the AJ-SPX900E can be used as a mass storage device.

Procedures for establishing a connection with a PC

- 1 Connect the USB cable to the USB 2.0 port.

<Notes>

- The USB 2.0 cable is not included with AJ-SPX900E. Please use a commercially available USB 2.0 cable (shield with a ferrite core).
- The length of the USB cable shall be not exceed 3 meters. Using a USB cable whose length is greater than 3 meters might result in erroneous operations.

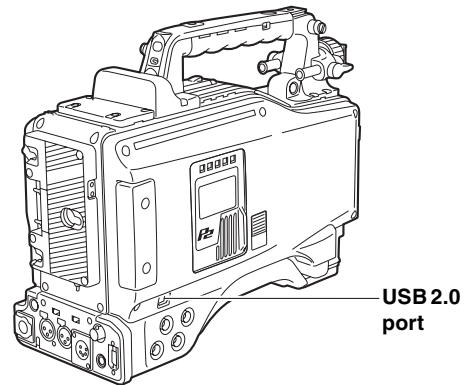

- 2 Open the <SYSTEM MODE> screen on the SYSTEM SETTING page from the menu, and set USB to ON.

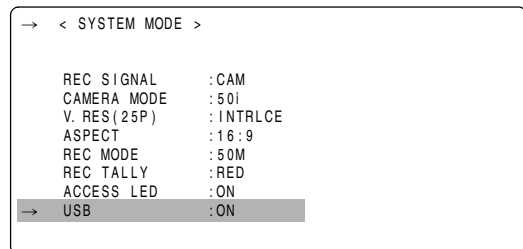

When you establish the USB connection for the first time, install the accessory P2 software for AJ-SPX900E on the PC. Refer to the Installation Manual for the details.

<Notes>

- A USB driver must be installed on the PC.
- AJ-SPX900E is only applicable to USB 2.0, not to USB 1.1.
- Only one AJ-SPX900E at a time must be connected to the PC via USB.
- The P2 card must not be removed when it is connected via USB.
- While a USB connection is established, the P2 card's access LED should not be lit except when access is being carried out.
- While the USB is turned ON, operations such as recording, playback and thumbnails will not be available.

During a USB connection, "DRIVE" is lit in the status indication area of a display window.

Also, "USB DRIVE" is displayed in the system information/warning area in the viewfinder.

When the connection is not correctly established, both of these indications blink.



3 There are two ways to terminate the USB mode, as follows:

- Turn the POWER switch of the AJ-SPX900E OFF.
- Set the USB to OFF from the menu (operations).

5-6 Mounting the Camera on a Tripod

When mounting the camera on a tripod, use the optional tripod adapter.

1 Mount the tripod adapter on the tripod.

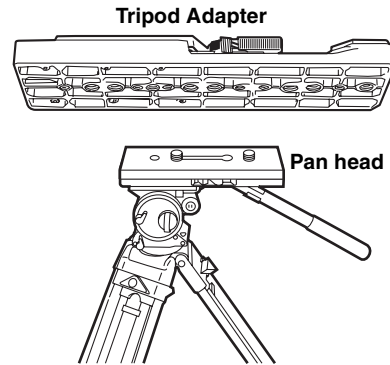

<Note>

Select an appropriate hole in the adapter, taking into account the center of gravity of the camera and tripod adapter combined.

Also, make sure that the diameter of the selected hole matches the diameter of the pan head screw.

2 Mount the camera on the tripod adapter. Slide the camera forward along the grooves until you hear a "click".

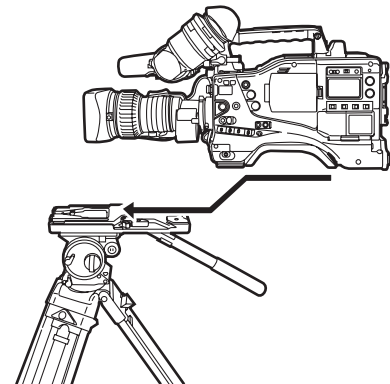

Removing the Camera from the Tripod Adapter

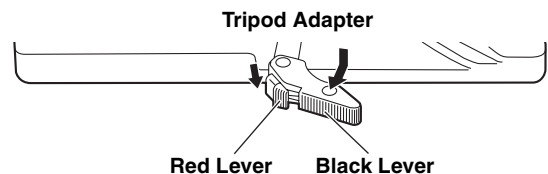

While holding the red lever down, move the black lever in the direction of the arrow, and slide the camera backward to remove it.

<Note>

If the tripod adapter pin does not return to its original position after the camera has been removed, hold the red lever down and move the black lever in the direction of the arrow again, in order to return the pin to its original position.

Please note that the camera cannot be mounted if the pin remains in the center.

5-7 Attaching the Shoulder Strap

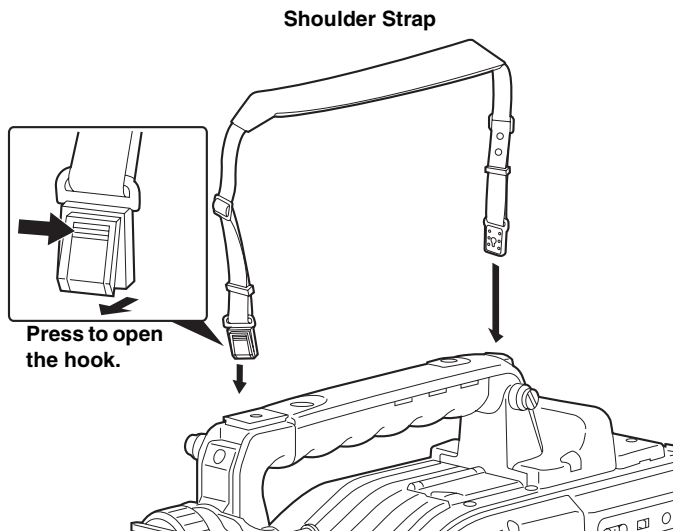

To detach the shoulder strap, first open the hooks, then detach the strap.

<Note>

Make sure that the shoulder strap is securely attached.

5-8 Attaching the Rain Cover

When using the SHAN-RC700 Rain Cover

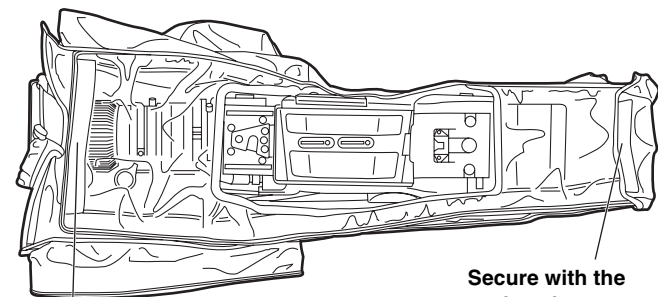
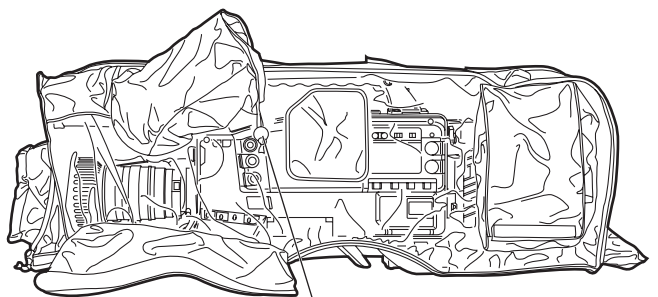

Secure with the surface fastener

5-9 Connecting the AJ-EC3E Extension Controller

Some functions can be remote-controlled when the AJ-EC3E extension control unit (optional) is connected to the camera. When the AJ-EC3E is connected, the camera automatically enters remote control mode after the power switches of both the camera and the AJ-EC3E are turned ON.

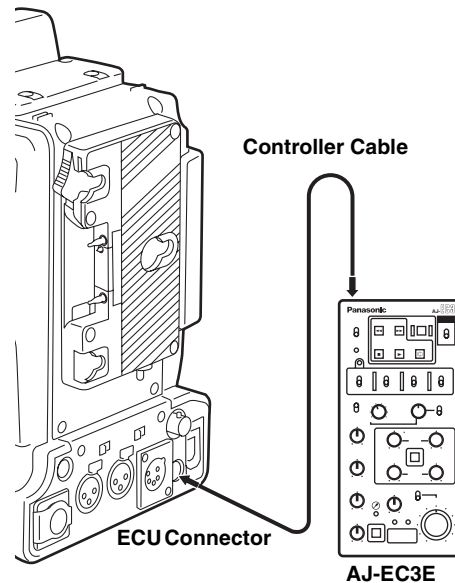

<Notes>

- Be sure to turn OFF both the camera and the AJ-EC3E power switches before connecting or disconnecting the controller cable.
- If ECU DATA SAVE is set to OFF, the camera-related setting values, which have been adjusted or set using the AJ-EC3E, will be canceled when the camera power switch is turned OFF. Also, the setting values cannot be written to an SD memory card. However, the menu settings performed using the AJ-EC3E can be written to an SD memory card. Next time the AJ-EC3E is connected, the setting values will return to the AJ-EC3E settings. ECU DATA SAVE can be selected from the <SW MODE> screen on the CAM OPERATION page.
- If ECU DATA SAVE is set to ON, the values adjusted or set using the AJ-EC3E are retained, even after the camera power switch is turned OFF.
- The USER switch on the camera does not function when the AJ-EC3E is connected.
- When controlling the shutter from the AJ-EC3E, the shutter speeds correspond to the speeds set by the menu on the camera, not the speeds written on the AJ-EC3E. The shutter speeds correspond as follows:

AJ-EC3E Shutter Speed Indication	Camera Shutter Speeds
100 (60)	POSITION1
120	POSITION2
250	POSITION3
500	POSITION4
1000	POSITION5
2000	POSITION6

5-10 Attaching the Front Audio Level Control Knob

If you use the Front Audio Level control frequently, attach the accessory knob so that it can be easily operated.

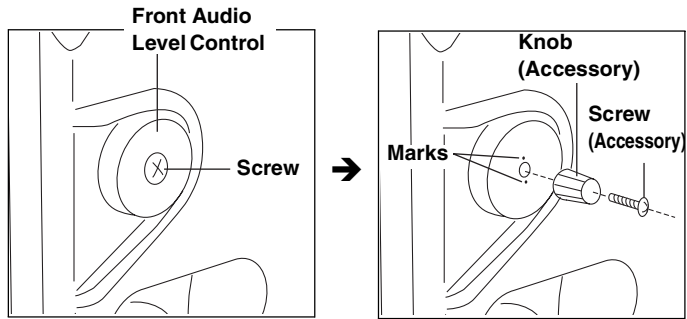

Remove the screw in the center of the Front Audio Level control, and attach the accessory knob using the screw (included). When attaching the knob, be sure to align the marks on the control with the marks on the knob.

Chapter 6 Manipulating Clips with Thumbnails

A clip is a data group that includes the images and voices created from one shooting session, together with additional information such as voice memos and meta data.

The following manipulations can be performed using the cursor and SET buttons, while checking the images displayed on the LCD monitor:

- Playback, delete, copy or restore the clip.
- Add a voice memo to the clip.
- Add or delete a shot mark on the clip thumbnail.
- Format P2 cards and SD memory cards.
- Upload the clip meta data from an SD memory card.

6-1 Thumbnail Manipulations Overview

Thumbnail screens are configured as follows:

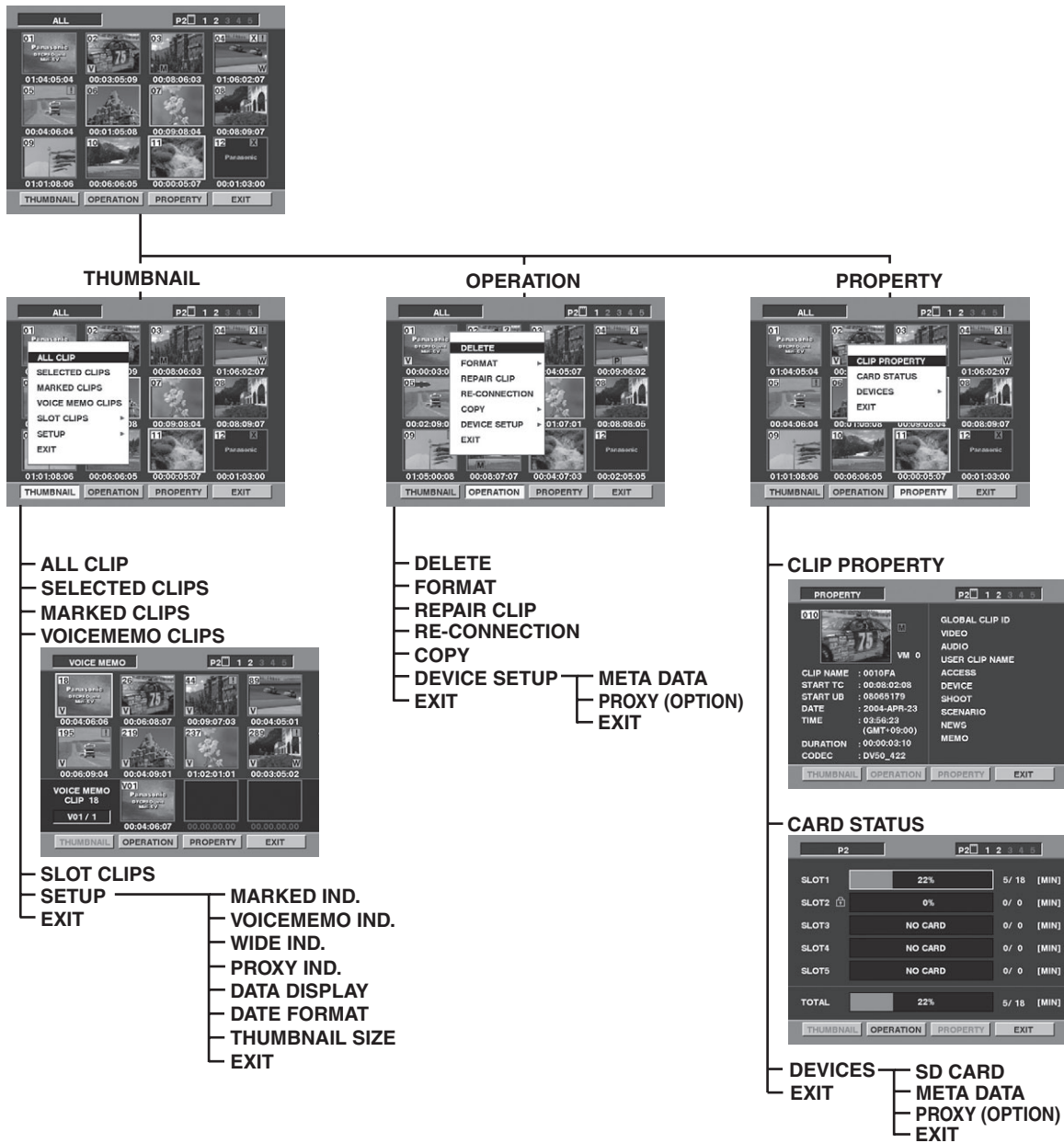

6-2 Thumbnail Screen

Press the THUMBNAIL button to display the thumbnail screen on the LCD monitor. Pressing the THUMBNAIL button again returns the display to the regular display. When switching is done from the regular screen display to the thumbnail screen display, all the clips will be displayed on the thumbnail screen.

Also, pressing the MENU BAR button in the thumbnail screen moves the pointer to the menu bar and enables thumbnail menu manipulation.

<Note>

With the TCG switch positioned at [SET], when the time code or user bits are set or when camera menus are being manipulated, thumbnails cannot be manipulated.

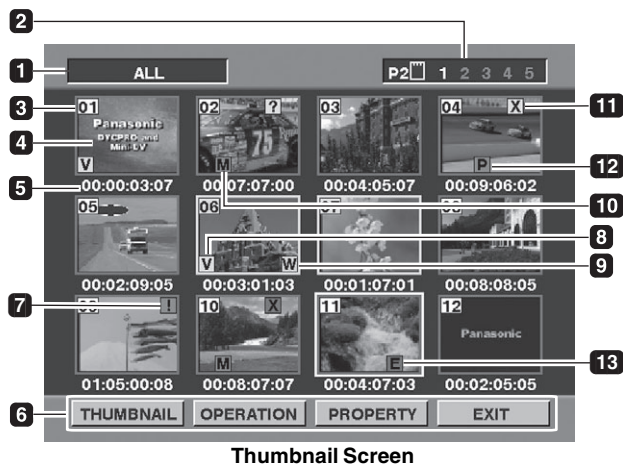

Thumbnail Screen

1 Display Mode

Indicates the thumbnail types displayed on the screen.

ALL: Display all clips.

SELECTED: Display randomly selected clips.

MARKED: Display clips with shot marks.

VOICE MEMO: Display clips with voice memo data.

SLOT: Display clips in the specified P2 card.

Please refer to [6-5 Switching the Thumbnail Display] for more information.

2 Slot Number

Indicates the P2 card in which the clip under the pointer is recorded. The slot number of the P2 card that contains the clip is displayed in yellow.

If the clip is recorded across multiple P2 cards, all the slot numbers of the P2 cards that contain the clip are displayed. The slot numbers of the other P2 cards, if inserted, are displayed in white.

3 Clip Number

The numbers set by the camera for all the clips recognised correctly by the P2 card. These numbers are allocated in chronological order, by shooting dates and times.

If clips cannot be played because of different recording formats, they are displayed in red.

4 Thumbnail

The image captured immediately after you start shooting is displayed as a thumbnail.

5 Time Display

You can set this to display the time code at the start of clip recording, the user bits at the start of clip recording, the shooting time, the shooting date or the shooting and date. Please refer to [6-16 Setting the Thumbnail Display Mode] for more information.

The factory setting is the time code at the start of clip recording.

6 Menu Bar

The Menu Bar includes menus for manipulating clips and switching/setting the thumbnail display.

Press the MENU BAR button on the thumbnail screen to manipulate the menu bar. Use the cursor (<|>) and SET buttons to select the menu.

THUMBNAIL:

To switch the thumbnail display and set the display mode.

OPERATION:

To delete clips and format a P2 card.

PROPERTY:

To display clip properties and P2 card status.

EXIT:

To return the pointer to the thumbnail.

7 Incomplete Clip Indicator

Indicates that although a clip is recorded across multiple P2 cards, one of these cards is not inserted into a P2 card slot.

8 Voice Memo Indicator

This marker is displayed for a clip with a voice memo attached. Please refer to [6-7 Voice Memo] for more information about voice memos.

9 Wide Clip Indicator

This marker is displayed for clips recorded with the 16:9 aspect ratio.

10 Shot Mark Indicator

This marker is displayed for a clip with a shot mark attached. Please refer to [6-6 Shot Mark] for more information about shot marks.

11 Defective Clip Indicator

This marker is displayed for defective clips, which may result from a variety of causes, e.g., powering-down during recording.

A clip displayed with a yellow corrupt marker can be restored. Please refer to [6-9 Restoring Clips] for more information.

A clip displayed with a red corrupt marker cannot be restored and must be deleted. If the clip cannot be deleted, format the P2 card.

When clips have different formats, [?] is displayed instead of [X].

12 Indicator for clips with proxy

This marker is displayed for clips with proxy attached.

13 Indicator for edit copy clips

This marker is displayed for clips whose edit copy operation was performed on the P2 deck. For more information on edit copy, see the AJ-SPD850 instruction manual.

6-3 Selecting Thumbnails

Multiple thumbnails can be randomly selected in the thumbnail screen.

- 1 Use the cursor buttons to move the pointer (yellow frame) to the desired clip and press the SET button. The frame around the selected thumbnail changes to a blue frame. Press the SET button again to deselect the clip.
- 2 Additional clips can be selected by repeating Step 1.

It is possible to display only the selected thumbnails in the thumbnail screen for playback. Please refer to [6-5 Switching the Thumbnail Display] for more information.

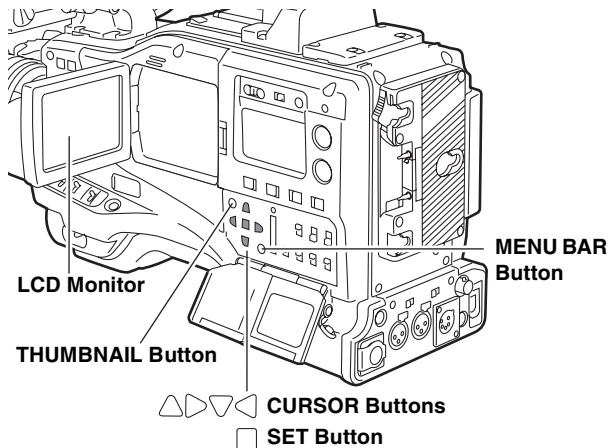

6-4 Playing Back Clips

- 1 Press the THUMBNAIL button. The thumbnail screen appears on the LCD monitor.
- 2 Use the cursor buttons to move the pointer over the desired clip.
- 3 Press the PLAY/PAUSE button, and the clip under the pointer will be played back on the LCD monitor. After playback of the clip under the pointer, subsequent clips are played back in order, according to when they were shot. The thumbnail screen returns after the last clip has been played back.

<Notes>

- When playing back clips, it is not necessary to “select” the clips (blue frames around the thumbnails).
 - Clips with clip numbers displayed in red cannot be played.
- 4 During playback, pressing the REW button starts 4× speed reverse playback, and the FF button starts 4× speed fast playback. Press the PLAY/PAUSE button to return to normal playback.
 - 5 During clip playback, pressing the PLAY/PAUSE button will temporarily stop (pause) the process. During a pause, pressing the REW button changes the pause position to the beginning of the previous clip, and the FF button changes the pause position to the beginning of the next clip.
 - 6 Pressing the STOP button during clip playback stops the playback and returns the display to the thumbnail screen.

<Note>

When playback is stopped, the position of the pointer remains on the clip that was being played back, regardless of where the playback started. However, when the THUMBNAIL button is pressed to close the thumbnail screen, the pointer will move to the starting clip (i.e., the clip with the earliest recording date and time), not the clip on which the pointer was last positioned.

6-5 Switching the Thumbnail Display

The display can be switched so that only those clips matching the specified conditions are displayed in the thumbnail screen.

- 1 Press the THUMBNAIL button.
The thumbnail screen appears on the LCD monitor.
- 2 Press the MENU BAR button. The pointer moves to the menu bar.

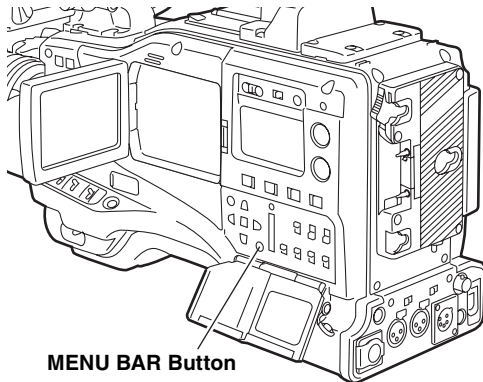

- 3 Move the pointer over THUMBNAIL and press the SET button to select it. A sub-menu appears. Switch the thumbnail display by selecting one of the following items:



ALL CLIPS:

Display all clips.

SELECTED CLIPS:

Display randomly selected clips.

MARKED CLIPS:

Display clips with shot marks attached.

VOICE MEMO CLIPS:

Display clips with voice memo data attached.

SLOT CLIPS:

Display clips recorded in the P2 card inserted in the specified slot.

When this item is selected, SLOT1 to SLOT5 are displayed as a sub-menu. Select the desired slot to display the clips.

SETUP:

Please refer to [6-16 Setting the Thumbnail Display Mode] for information about this item.

EXIT:

Close the sub-menu.

6-6 Shot Mark

A shot mark can be added to a clip thumbnail to distinguish this clip from the others.

- 1 Press the THUMBNAIL button.
The thumbnail screen appears on the LCD monitor.
- 2 Use the cursor buttons to move the pointer over the clip to which you want to attach a shot mark.
- 3 Press the Shot Mark button.

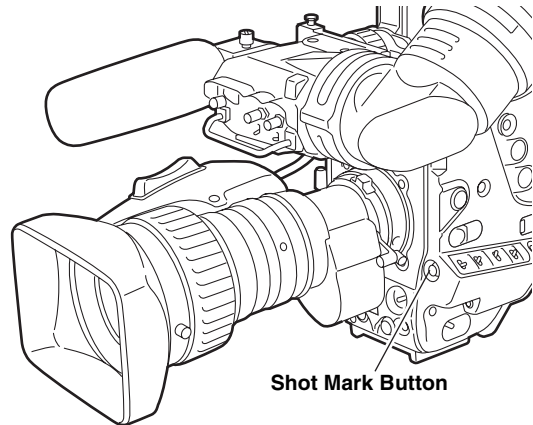

- 4 A shot mark will be attached to the clip thumbnail under the pointer.
To delete a shot mark, reposition the pointer over the clip and press the Shot Mark button.

<Notes>

- A shot mark can be attached during recording. Please refer to [3-10 Shot Mark Function] for more information.
- When adding a shot mark to (or deleting the shot mark from) a clip recorded across multiple P2 cards, do this with all these P2 cards inserted into P2 card slots.

6-7 Voice Memo

A voice memo is audio data that can be attached to the clip separately from the voice recorded during shooting.

<Note>

A voice memo can be attached during recording. Please refer to [3-9 Voice Memo Function] for more information.

6-7-1 Playing Back Voice Memos

- 1 Press the THUMBNAIL button.
The thumbnail screen appears on the LCD monitor.
- 2 Press the MENU BAR button. The pointer moves to the menu bar.
- 3 From the MENU BAR, select THUMBNAIL → VOICE MEMO CLIPS.
The clip thumbnails with voice memos attached are displayed in the upper section of the LCD monitor. The lower section of the LCD monitor shows information about the voice memo on the clip selected by the pointer.

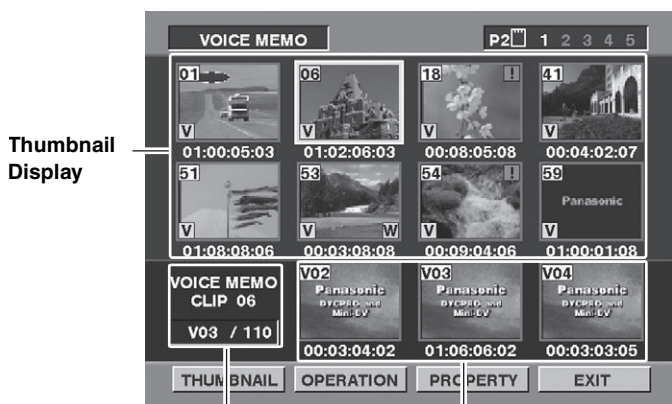

Thumbnail Display

Shows the still image that the voice memo is related to.

Shows the total number of voice memos attached to the clip.

- 4 Move the pointer over the clip that contains the desired voice memo to playback and press the SET button.
The pointer moves to the lower part of the LCD monitor.

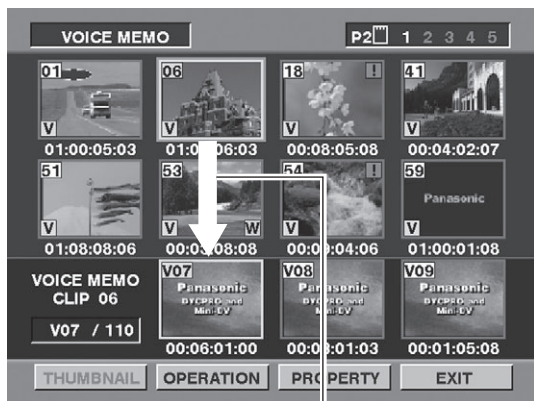

The pointer moves down.

- 5 Press the left/right cursor buttons (<|>) to move the pointer over the still image that is related to the voice memo you wish to play back. Then, press the SET button.
- 6 The voice memo will be played back.
During voice memo playback, the still image related to the voice memo is displayed on the LCD monitor and the viewfinder. The video output signal is also the still image.
To stop the voice memo playback, press the STOP button.
- 7 To return the pointer to the thumbnail display after playback of a voice memo, press the MENU BAR button to move the pointer to the menu bar, and then select EXIT.

<Note>

The voice memo playback signal is emitted through the speaker and the PHONES jack on the camera. This signal is not emitted from the AUDIO OUT jack.

6-7-2 Recording a Voice Memo

During thumbnail display, voice memos can be added to the clip on which the pointer is positioned.

- 1 Press the THUMBNAIL button.
The thumbnail screen appears on the LCD monitor.
- 2 Use the cursor buttons to move the pointer over the clip to which you want to attach a voice memo.
- 3 Press the Voice Memo button and record the voice memo through the Voice Memo Microphone.
“VOICE REC” is displayed at the top of the screen.

<Notes>

- When a voice memo is attached during thumbnail display, the voice memo is related to the first still image of the clip. Please refer to [3-9 Voice Memo Function] for more information.
- When the power is abruptly turned off while a voice memo is being recorded during playback of a clip, the clip will not be affected by this, but the voice memo will not be recorded.

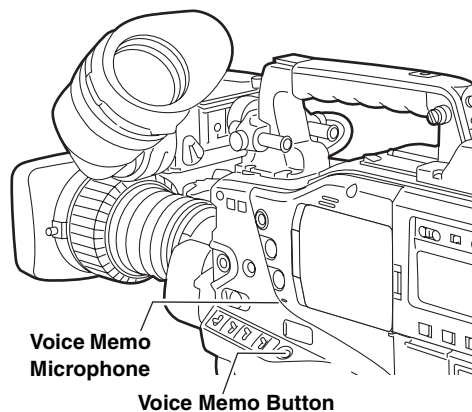

- 4 Press the Voice Memo button or the stop button again to stop recording.

6-7-3 Deleting Voice Memos

- 1 Perform Steps 1 to 4 in the [6-7-1 Playing Back Voice Memos] section to select the voice memo in the clip.
- 2 Move the pointer over the clip you want to delete, and press the MENU BAR button. The pointer moves to the menu bar.
- 3 From the menu bar, select OPERATION → DELETE. YES and NO appear to confirm deletion. Use the cursor buttons and the SET button to select YES. The voice memo is deleted.

6-8 Deleting Clips

- 1 Press the THUMBNAIL button. The thumbnail screen appears on the LCD monitor.
- 2 Use the cursor buttons to move the pointer over the clip you want to delete. Press the SET button to select the clip.
- 3 Press the MENU BAR button and select OPERATION → DELETE from the menu bar.
- 4 The following screen appears. Use the cursor buttons and the SET button to select YES.

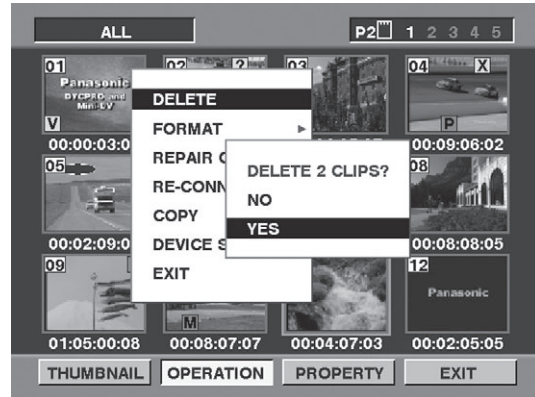

- 5 The clip is deleted. All selected clips (in blue-green frames) are deleted by this operation.

<Note>

Pressing the SET button stops the deletion operation in the middle.

6-9 Restoring Clips

Restores clips that are defective as a result of sudden powering-down during recording, or removal of the P2 card being accessed.

<Note>

Only those clips with yellow corrupt clip markers can be restored. Delete the clips with red corrupt clip markers. If the clip cannot be deleted, format the P2 card.

During restoration of the clips, however, the defective-clip indicator may change from yellow to red, resulting in inability to restore the clips.

- 1 Press the THUMBNAIL button.
The thumbnail screen appears on the LCD monitor.
- 2 Use the cursor buttons to move the pointer over the clip you want to restore (defective clips are indicated by corrupt clip marks).
Press the SET button to select the clip.
- 3 Press the MENU BAR button, and select OPERATION → REPAIR CLIP from the menu bar.
- 4 The confirmation window appears. Use the cursor buttons and the SET button to select YES.

6-10 Reconnection of incomplete clips

Incomplete clips may be generated when clips recorded on multiple P2 cards (connected clips) are separately copied to different cards. Reconnection function generates one clip (the original, connected clip) from incomplete clips.

- 1 Press the THUMBNAIL button.
The thumbnail screen appears on the LCD monitor.
- 2 Use the cursor and SET button to select incomplete clips to reconnect.
Usually, thumbnails of incomplete clips (clips with  marker) are displayed in line.
- 3 Press the MENU BAR button and select OPERATION → RE-CONNECTION from the menu bar.
- 4 The confirmation window appears. Use the cursor buttons and SET button to select YES.

<Note>

 indication stays illuminated until all the incomplete clips that comprise the original clip are reconnected.

6-11 Copying clips

Selected clips can be copied to the P2 card or SD memory card in the desired slot.

- 1 Press the THUMBNAIL button.
The thumbnail screen appears on the LCD monitor.
- 2 Use the cursor buttons to move the pointer to the desired clip and press the SET button.
- 3 Press the MENU BAR button and select OPERATION → COPY from the menu bar.
Select Slot 1-5 or SD memory card as the destination.

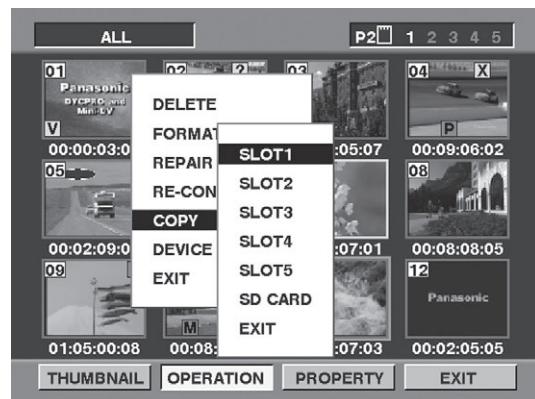

- 4 The confirmation window appears. Use the cursor buttons and SET button to select YES.

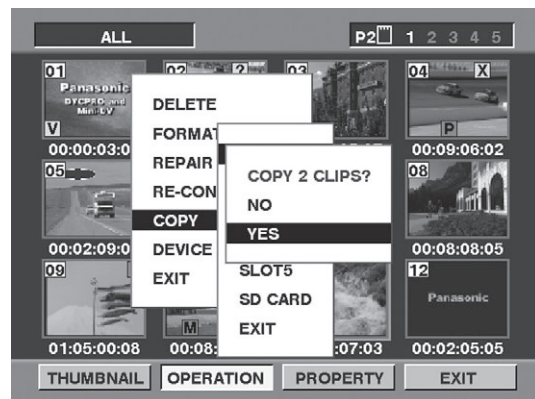

<Note>

- Do not turn the power off or remove or insert a card during copying. If you should accidentally perform one of the above operations, defective clips will be generated. Delete them, and then copy them again.
- When clips are copied to P2 cards, all the information on the clips is copied. However, when they are copied to the SD memory card*1, video and sound information is not copied, only thumbnails, clip metadata, icons, Voice Memo, proxy, and real-time metadata.
- When there is insufficient recording capacity on the destination, the message "LACK OF REC CAPACITY" is displayed, and copying will not proceed. When clips to be copied include some with defects, the message "CANNOT ACCESS" is displayed, and copying will not proceed. If selected clips include any that are already recorded on the destination P2 card, copying will not proceed.
- To stop copying, press the SET button. Clips currently being copied to the destination will be deleted.
- When identical clips exist on the destination card, the "OVERWRITE?" is displayed. Select "YES" or "NO".

*1 Regarding SD memory cards to be used, see <Cautions in using SD memory cards> (page 18).

6-12 Setting of Clip Meta Data

Information such as the name of person who shot the video, the name of the reporter, the shooting location, or a text memo can be read from the SD memory card, and can be recorded as Clip Meta Data.

Reading Clip Meta Data (metadata upload)

- 1 Insert the SD memory card that contains the Clip Meta Data (metadata upload file).
- 2 Press the THUMBNAIL button. The thumbnail screen appears on the LCD monitor.
- 3 Press the MENU BAR button. The cursor moves to the menu bar.
- 4 Select OPERATION → DEVICE SETUP → META DATA → LOAD from the menu bar, and press the SET button.

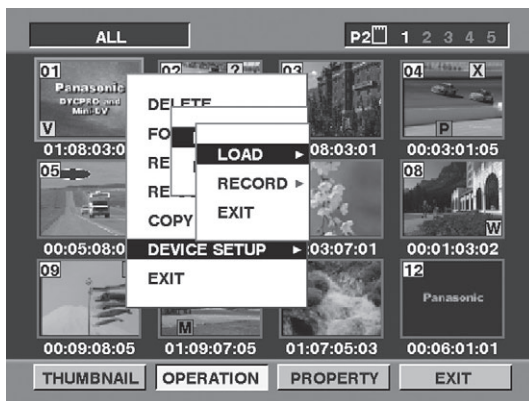

- 5 Names of metadata upload files stored on the SD memory card are displayed. Select the desired files using the cursor buttons, and choose YES. Upload starts. Uploaded metadata is retained even if the power is turned off. For confirmation of uploaded data, see [6-17-4 Confirmation of Metadata Upload].

Clip Meta Data items

Clip Meta Data includes the following items: Underlined items can be set by reading the metadata upload file on the SD memory card. Other items are set automatically during shooting. Using the latest update version of P2 viewer, metadata upload files can be written to SD memory cards using a PC. Download the latest update version of P2 viewer from the following URL and install it to your PC:

<http://panasonic.biz/sav/p2>

Regarding SD memory cards to be used, see <Cautions in using SD memory cards> (page 18).

<Note>

The file which was edited by except P2 viewer is displayed as "UNKNOWN DATA", and may not be read.

GLOBAL CLIP ID:

Displays the global clip ID, which indicates the shooting status of the clip.

VIDEO: Displays [FRAME RATE] (frame rate of the clip), [PULL DOWN], and [ASPECT RATIO].

AUDIO: [SAMPLING RATE] (sampling frequency of recorded sound) and [BITS PER SAMPLE] (digitized bit[s] of recorded sound).

USER CLIP NAME:

Displays the clip name specified by the user.*1

ACCESS: Displays [CREATOR] (person who recorded the clip), [CREATION DATE] (date when the clip was recorded), [LAST UPDATE PERSON] (person who made the latest update of the clip), and [LAST UPDATE DATE] (date of the latest update of the clip).

DEVICE: Displays [MANUFACTURER] (name of the device manufacturer), [SERIAL NO.] (serial number of the device) and [MODEL NAME] (model name of the device).

SHOOT: Displays [SHOOTER] (name of the person who shot the video), [START DATE] (start date of shooting), [END DATE] (end date of shooting), and [LOCATION] ALTITUDE/LONGITUDE/LATITUDE/SOURCE/PLACE_NAME (altitude, longitude, latitude, and source of the information and name of the location).

SCENARIO*2:

Displays [PROGRAM NAME], [SCENE NO.], and [TAKE NO.].

NEWS: Displays [REPORTER] (name of the reporter), [PURPOSE] (purpose of shooting), and [OBJECT] (object of shooting).

MEMO*3: Displays [OFFSET] (location of the frame where the text memo is added), [TEXT] (contents of the text memo), and [PERSON] (person who recorded the text memo added to the clip). The AJ-SPX900E can record one text memo per clip.

- *1 When there is no information on the metadata upload file, the global clip ID is used as the USER CLIP NAME.
- *2 Be sure to enter PROGRAM NAME when entering SCENARIO. It is not possible to record only the SCENE NO or TAKE NO.
- *3 Be sure to enter TEXT when entering MEMO. It is not possible to record only PERSON or OFFSET.

<Note>

The AJ-SPX900E only displays printable ASCII characters.

To set whether or not the uploaded metadata is recorded

Set ON/OFF by selecting META DATA → RECORD from the menu bar.

6-13 Setting of Proxy (optional)

By attaching the video encoder card (AJ-YAX800G, optional) either to the optional slot or Slot 5, it is possible to specify the proxy recording setting.

Select OPERATION → DEVICE SETUP → PROXY from the menu bar to specify the setting.

For more information on settings, see the video encoder card instruction manual.

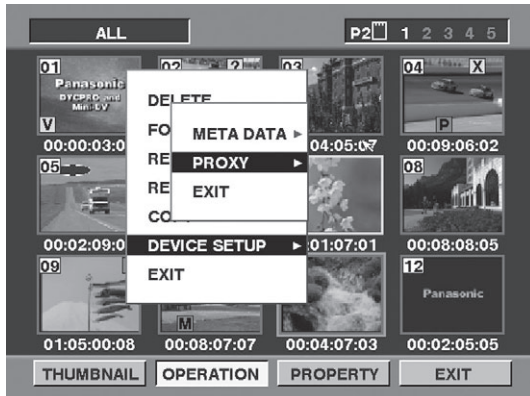

6-14 Formatting a P2 Card

- 1 Press the THUMBNAIL button. The thumbnail screen appears on the LCD monitor.
- 2 Press the MENU BAR button. The pointer moves to the menu bar.
- 3 From the menu bar, select OPERATION → FORMAT. The following screen appears. Select the slot number for the P2 card you want to format. Select EXIT if formatting is not required.

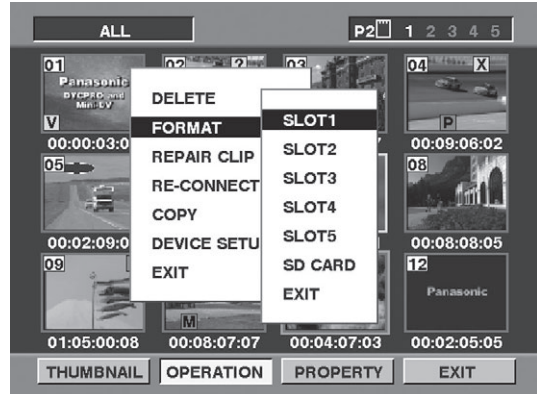

- 4 The following screen appears. Use the cursor buttons and the SET button to select YES.

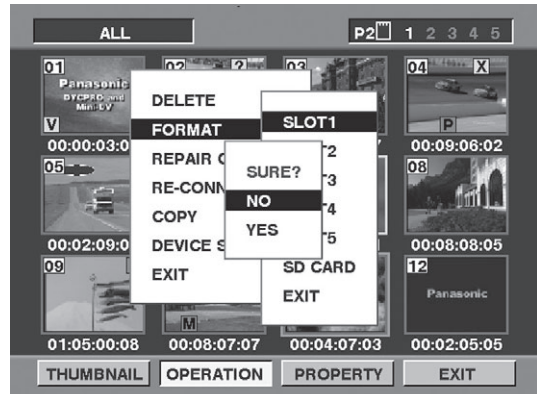

- 5 The selected P2 card is formatted.

6-15 Formatting SD memory cards

SD memory cards can also be formatted from the thumbnail screen. With an SD memory card inserted into the camera-recorder, perform the following operation:

- 1 Press the THUMBNAIL button.
The thumbnail screen appears on the LCD monitor.
- 2 Press the MENU BAR button. The pointer moves to the menu bar.
- 3 From the menu bar, select OPERATION → FORMAT. The following screen appears. Select “SD-CARD”. Select “EXIT” if formatting is not required.

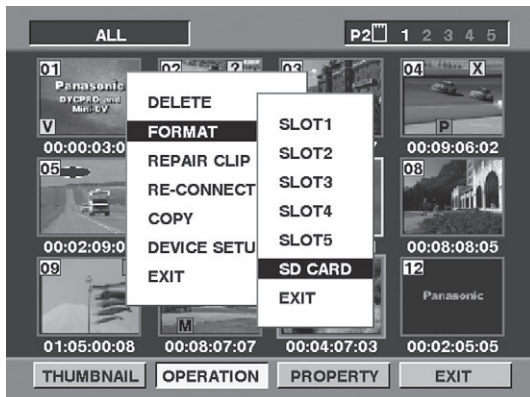

- 4 The following screen appears. Use the cursor buttons and the SET button to select YES.

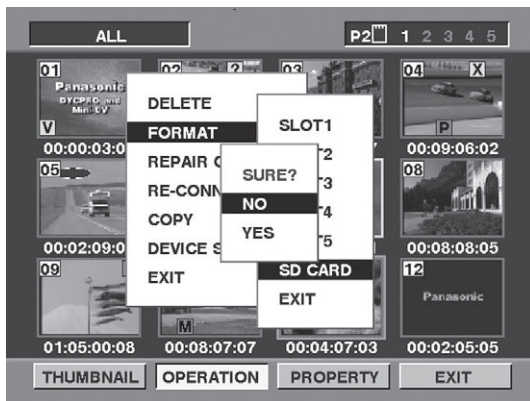

- 5 The SD memory card is formatted.

<Note>

SD memory cards can also be formatted from the menu screen. For more information, see [4-10-2 Formatting, Writing and Reading an SD memory card].

6-16 Setting the Thumbnail Display Mode

The thumbnail display mode can be customised to suit your preferences.

- 1 Press the THUMBNAIL button.
The thumbnail screen appears on the LCD monitor.
- 2 Press the MENU BAR button. The pointer moves to the menu bar.
- 3 From the menu bar, select THUMBNAIL → SETUP. The following screen appears.



MARKER IND. :

Switches the shot mark marker between indication and no indication (ON/OFF). The factory setting is ON (indication).

VOICE MEMO IND. :

Switches the voice memo marker between indication and no indication (ON/OFF). The factory setting is ON (indication).

WIDE IND. :

Switches the wide marker between indication and no indication (ON/OFF). The factory setting is ON (indication).

PROXY IND. :

Switches the proxy indicator between indication and no indication (ON/OFF). The factory setting is ON (indication).

DATA DISPLAY:

The time display field of the clip offers a choice of Time Code (TC), User Bits (UB), Shooting Time (TIME) or Shooting Date (DATE)/Shooting Time and Date (Time DATE). The factory setting is Time Code.

DATE FORMAT:

You can specify the display order for the shooting date as either Year/Month/Day (YMD), Month/Day/Year (MDY) or Day/Month/Year (DMY). The factory setting is Year/Month/Day.

This setting is reflected in the recording date shown in the clip property and the shooting date shown when DATE is selected under the item DATA DISPLAY.

THUMBNAIL SIZE:

For the size of thumbnails displayed on one screen, either LARGE (3 × 2 thumbnails displayed) or NORMAL (4 × 3 thumbnails displayed) can be selected. The factory default value is NORMAL.

EXIT:

Returns to the previous menu.

6-17 Properties

The clip's properties and the P2 card's status are displayed.

6-17-1 Clip Property

From the menu bar, select PROPERTY → CLIP PROPERTY. The following screen appears.

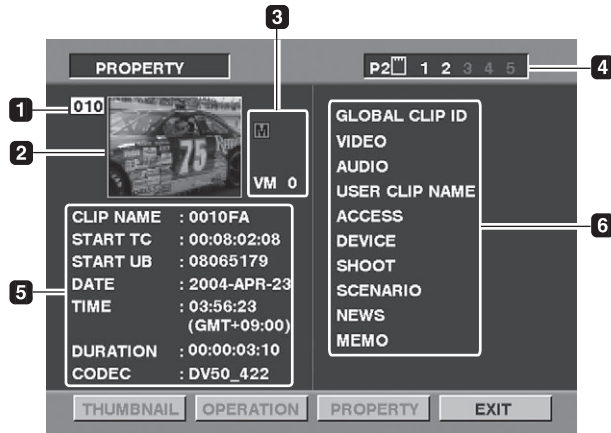

1 Clip Number

2 Thumbnail

3 Slip Information

Displays the number of markers and voice memos attached to the clip.

The mark appears if the clip is recorded on a write-protected P2 card.

4 Slot Number

5 Clip Information

Displays detailed information about the clip.

START TC:

The time code value at the start of the recording.

START UB:

The user bit value at the start of the recording.

TIME: The time at the start of the recording.

DATE: The date of the recording.

DURATION:

The time length of the clip.

CODEC: The recording format of the clip.

6 Clip Meta Data

Displays more detailed data about the clip. Use the cursor buttons to move the pointer, and press the SET button to check the detailed content. The underlined items are automatically set during shooting. For more information on displayed metadata, see [6-12 Setting of Clip Meta Data].

6-17-2 P2 Card Status Display

From the menu bar, select PROPERTY → CARD STATUS. The following screen appears.

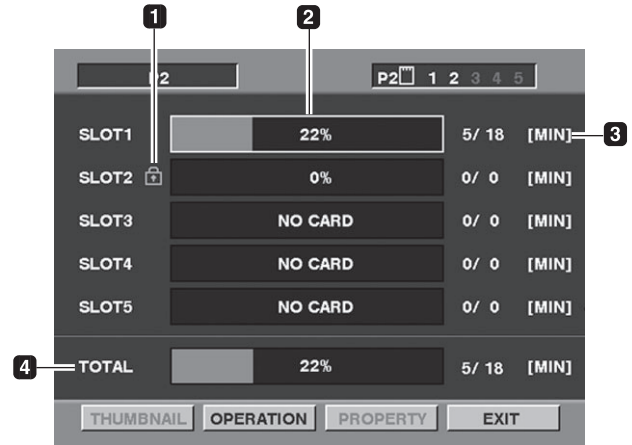

1 Write-protect Mark

The mark appears if the P2 card is write-protected.

2 P2 Card Status

The remaining memory capacity of the P2 card is indicated by a bar graph and percentage.

The following indications may appear, depending on the card status:

FORMAT ERROR:

An unformatted P2 card is inserted.

NOT SUPPORTED:

An unsupported card is inserted in the camera.

NO CARD:

P2 cards are not inserted.

To check unique information, such as serial number or user ID, move the cursor to the desired P2 card and press the SET button.

3 P2 Card Remaining Capacity/Total Capacity

Displays the P2 card remaining capacity and total capacity in minutes. The total of the remaining memory capacity for each P2 card that is displayed may not match the actual total remaining memory capacity for the P2 cards because only the figure in minute is displayed.

4 Slots Total

Displays the total capacity of the 5 slots.

Please note that the remaining capacity of a write-protected P2 card is not included in the total remaining capacity.

6-17-3 SD memory card Status Display

The status display enables a confirmation of the SD memory card formatted condition, available memory capacity etc.

From the menu bar, select PROPERTY → DEVICES → SD CARD.

If the format is compatible with SD standards, the message “SD STANDARD: SUPPORTED” is displayed.

If the format is not compatible with SD standards, the message “SD STANDARD: NOT SUPPORTED” is displayed. If this is the case, writing or reading will not be successful. Format the card with the AJ-SPX900E. For more on formatting SD memory cards, see [6-15 Formatting SD memory cards].



6-17-4 Confirmation of Metadata Upload

The contents of the metadata upload file that is read from the SD memory card can be checked.

From the menu bar, select PROPERTY → DEVICES → META DATA. The following screen appears:

For more information on each item, see [6-12 Setting of Clip Meta Data].

The META NAME is the meta data name written in the meta data upload file, and is not recorded in the clip.

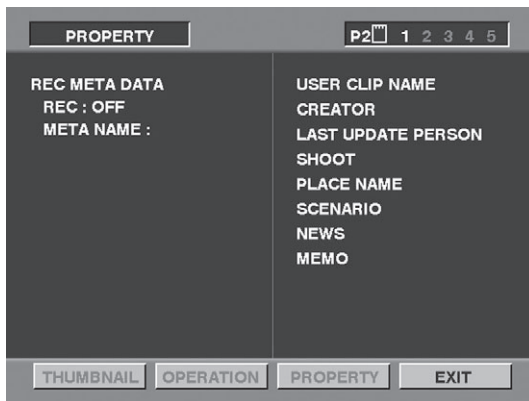

6-17-5 Video Encoder Card Status Display (optional)

Attaching the video encoder card (AJ-YAX800G, optional), select PROPERTY → DEVICES → PROXY from the menu bar.

The number of the slot in which the video encoder card is inserted is displayed.

Chapter 7 Maintenance and Inspections

7-1 Inspections Before Shooting

Make sure you check that the system is operating normally before embarking on a shoot. We recommend using a color video monitor to check the image.

7-1-1 Preparing for Inspections

- 1 Mount a charged battery pack.
- 2 Turn the power switch ON and check that 5 or more BATT indication marks appear.
 - If fewer than 5 BATT indication marks appear, replace the battery with a fully-charged battery.

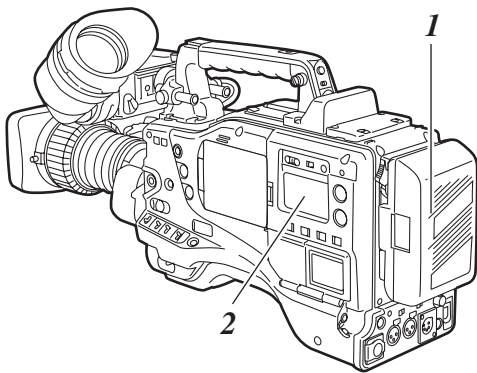

- 3 Insert a P2 card into the card slot and close the slide cover. Confirm that the P2 card access LED for the inserted card slot lights up in orange. If P2 cards are inserted into multiple card slots, only the P2 card access LED for the first-inserted P2 card lights up in orange. Then, the other P2 card access LEDs light up in green when P2 cards are inserted.
If the access LED for the P2 card slot in which a P2 card is inserted keeps blinking in green, or if there is no display, recording is not possible on that particular P2 card.

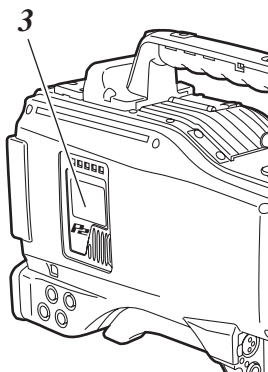

7-1-2 Inspecting the Camera Unit

- 1 Set the zoom to electric zoom mode and check the zoom operation.
Check that the image changes to telephoto and wide angle.
- 2 Set the zoom to manual zoom mode and check the zoom operation.
Turn the manual zoom lever to check that the image changes to telephoto and wide angle.
- 3 Set the iris to automatic adjustment mode and aim the lens at objects with different degrees of brightness, to check that the automatic iris adjustment operates normally.
- 4 Set the iris to manual adjustment mode and turn the iris ring, to check the manual iris adjustment.
- 5 While holding down the instant iris automatic adjustment button, aim the lens at objects with different degrees of brightness, to check that the instant iris automatic adjustment operates properly.
- 6 Return the iris to automatic adjustment mode and change the GAIN switch setting to L, M, and H, to check the following items:
 - The iris is adjusted for objects with the same brightness according to the switch setting.
 - The gain value displayed on the viewfinder screen changes according to the switch setting.
- 7 When a lens with an extender is mounted, set the extender to the operating position to check that the extender operates properly.

7-1-3 Inspecting the Memory Recording Functions

Make sure you successively carry out the inspections from [1. Inspecting the P2 Card Recording] to [4. Inspecting the Earphone and Speaker].

1. Inspecting the P2 Card Recording

- 1** Check on the display inside the viewfinder that the remaining P2 card recording capacity is sufficient. Please refer to [P2 Card Remaining Free Space/capacity Indication] (page 53) for information about P2 card remaining recording capacity.
- 2** Set the TCG switch to [R-RUN].
- 3** Set the DISPLAY switch to [TC].
- 4** Press the camera's REC START/STOP button to check the following items:
 - The P2 access LED blinks in orange.
 - The REC lamp inside the viewfinder lights up.
 - System warnings do not appear inside the viewfinder.
- 5** Press the camera's REC START/STOP button again. This step confirms that the P2 access LED is on and showing orange, and the REC lamp in the viewfinder is turned off.
- 6** Using the REC button on the handle, repeat Steps 4 to 5 to check the same operation. Check the VTR button on the lens in the same way.
- 7** Press the LIGHT button to check that the screen brightness in the display window increases.
- 8** Press the PLAY button to check that the clip that has just been shot is played back from the beginning. Check that recording and playback operate properly.
- 9** When multiple P2 cards are inserted into the P2 card slots, press the USER MAIN button to select the P2 card used for recording. Repeat the operations in Steps 4 to 5 and 8 to check that recording and playback operate properly.

2. Inspecting the Audio Level Automatic Adjustment

- 1** Set the AUDIO SELECT CH1 and CH2 switches to [AUTO].
- 2** Set the AUDIO IN CH1 and CH2 switches to [FRONT].
- 3** Aim the microphone connected to the MIC IN jack at an appropriate sound source. Then, check that the level displays for both CH1 and CH2 change according to the sound level.

3. Inspecting the Audio Level Manual Adjustment

- 1** Set the AUDIO IN CH1 and CH2 switches to [FRONT].
- 2** Set the AUDIO SELECT CH1 and CH2 switches to [MAN].
- 3** Turn the AUDIO LEVEL CH1 and CH2 controls. Check that the level display increases when the controls are turned to the right.

4. Inspecting the Earphone and Speaker

- 1** Turn the MONITOR control to check that the speaker volume changes.
- 2** Connect an earphone to the PHONES jack. Check that the speaker is turned off and the microphone sound can be heard from the earphone.
- 3** Turn the MONITOR control to check that the earphone volume changes.

5. Inspection for Using an External Microphone

- 1** Connect an external microphone to the AUDIO IN CH1 and CH2 connectors.
- 2** Set the AUDIO IN CH1 and CH2 switches to [REAR].
- 3** Set the LINE/MIC/+48V selector switches on the rear panel to [MIC] or [+48V], depending on the power supply type of the external microphone.
 - MIC:** For a microphone with internal power supply.
 - +48V:** For a microphone with external power supply.
- 4** Aim the microphone at a sound source. Then check that the audio level meter in the display window and the audio level display inside the viewfinder change according to the sound level. The channels can also be checked separately by connecting a single microphone to each channel.

6. Inspection of the clock, time code, and user bits

- 1** Set the user's bit as required.
Please refer to [4-5-1 Setting the User Bits] for the setting procedures.
- 2** Set the time code.
Please refer to [4-5-3 Setting the Time Code] for the setting procedures.
- 3** Set the TCG switch to [R-RUN].
- 4** Press the REC START/STOP button.
Check that the counter display number changes as recording progresses.
- 5** Press the REC START/STOP button again.
Check that recording stops and the counter display number stops changing.
- 6** Set the TCG switch to [F-RUN].
Check that the counter display number changes regardless of recording status.
- 7** Set the DISPLAY switch to [UB].
Each time the HOLD button is pressed, make sure that the displayed value changes in the following sequence: VTCG → DATE → TIME → No display (time zone) → TCG; and also verify that the displayed value is correct.
If DATE, TIME, or time zone is not correct, refer to [4-5-2 Setting the Internal Clock's Date and Time] for guidance on setting the correct values.

<Note>

Note that date and time data set for DATE, TIME, and time zone is recorded in clips, and affects the playback sequence, etc. at the time of thumbnail manipulations.

7-2 Maintenance

7-2-1 Cleaning Inside the Viewfinder

- Do not use thinner or other solvents to remove dirt from the viewfinder.
- Wipe the lens with a commercially available lens cleaner.
- DO NOT wipe the mirror. If dirt or rubbish is sticking on the mirror, remove it with a commercially available air blower.

7-2-2 Phenomenon Inherent to CCD Cameras

Smears

Smears may appear when shooting an object with very high brightness.

This phenomenon may appear more frequently as the electronic shutter speed increases.

7-2-3 Replacing the Backup Battery

The camera is shipped from the factory with a backup battery already mounted.

When the battery runs out, the [BACK UP BATT EMPTY] display appears on the viewfinder screen for 5 seconds after the power switch is turned ON.

The internal clock stops operating when the battery runs out. Also, the TCG time code value returns to [00:00:00:00], and the time code backup is disabled. The battery must be replaced.

Please consult your nearest service center for replacement with a new battery (CR2032).

The backup battery is visible when the panel on the LCD monitor side is removed (right side when viewed from the front).

<Note>

Please contact the store where you purchased the camera or an authorised service provider when replacing the battery.

7-2-4 Connector Signals

DC IN	
1	GND
2	NC
3	NC
4	+12V

Panasonic Part No. K1AA104H0024
 Manufacturer Part No. HA16RX-4P(SW1)
 (Hirose Electric Co.)

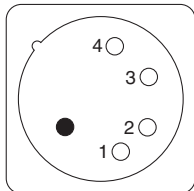

<Note>

Confirm correct polarity when using an external power supply.

FRONT MIC IN	
1	GND
2	AUDIO IN (H)
3	AUDIO IN (C)

Panasonic Part No. K1AB103B0013
 Manufacturer Part No. NC3FBH2
 (Eye-Trek)

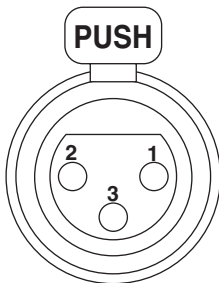

AUDIO IN	
1	GND
2	AUDIO IN (H)
3	AUDIO IN (C)

Panasonic Part No. K1AB103A0007
 Manufacturer Part No. HA16PRM-3SG
 (Hirose Electric Co.)

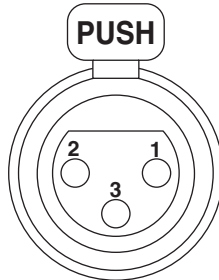

GPS	
1	GPS TXA
2	GPS RXA
3	GPS VBAT
4	START
5	GPS VCC
6	GPS GND

Panasonic Part No. K1AB106J0010
 Manufacturer Part No. HR10A-7R-6SC
 (Hirose Electric Co.)

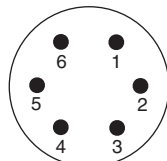

<Note>

The camera's REC START/STOP is allocated to pin No. 4.

AUDIO OUT	
1	GND
2	L CH OUT (H)
3	L CH OUT (C)
4	R CH OUT (H)
5	R CH OUT (C)

Panasonic Part No. K1AA105H0007
 Manufacturer Part No. HA16RD-5P
 (Hirose Electric Co.)

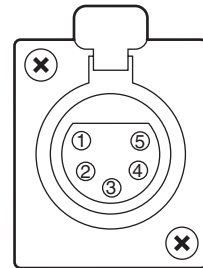

ECU	
1	CAM CONT
2	CAM DATA
3	NC
4	ECU ON
5	UNREG 12V
6	GND

Panasonic Part No. K1AB106J0010
 Manufacturer Part No. HR10A-7R-6SC
 (Hirose Electric Co.)

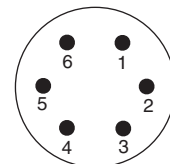

DC OUT	
1	GND
2	NC
3	NC
4	+12V

Panasonic Part No. VJS3824A004
 Manufacturer Part No. HR10A-7R-4SC
 (Hirose Electric Co.)

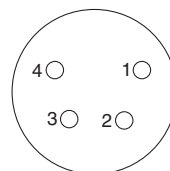

7-3 Warning System

7-3-1 Warning Description Tables

If a problem is detected immediately after the power is turned on, or during operation, this will be indicated by the WARNING lamp, lamps inside the viewfinder and a warning tone.

<Note>

The WARNING lamp has the highest priority, followed by the tally lamp, and then the warning tone. When multiple errors occur simultaneously a higher priority indication will be triggered. The [WIRELESS RF], however, may not be indicated, depending on the menu setting.

1. System Errors

Display window indication	The error code lights up.
WARNING lamp	Blinks 4 times per second.
Tally lamp	Blinks 4 times per second.
Viewfinder	The SYSTEM ERROR indication and the error code light up.
Warning tone	Beeps continuously.
Warning description	An error in the reference signal or the communication.
Recording/playback operation	The operation stops.
Countermeasures	Please confirm [7-3-2 Error Codes] and consult your nearest service centre.

2. Card removal error

Display window indication	Error code E-30 appears.
WARNING lamp	Blinks 4 times per second.
Tally lamp	Blinks 4 times per second.
Viewfinder	The "TURN POWER OFF" indicator blinks.
Warning tone	Continues to beep.
Warning description	The P2 card being accessed has been removed, resulting in an error in the internal memory of the camera-recorder.
Recording/playback operation	Cannot be performed.
Countermeasures	Turn off the power to the camera-recorder. If there is an error in a clip on the removed P2 card, repair the clip.

3. Battery Empty

Display window indication	All 7 bar indicators for battery remaining capacity start blinking.
WARNING lamp	Lights up.
Tally lamp	Blinks once per second.
Viewfinder	The BATT LED lights up.
Warning tone	Beeps continuously.
Warning description	The battery has run out.
Recording/playback operation	The operation stops.
Countermeasures	Replace the battery.

4. Write-protect

Display window indication	All 7 bar indicators for remaining MEDIA capacity start blinking.
WARNING lamp	Continues to light up until an operation is performed.
Tally lamp	Continues to blink 4 times per second until an operation is performed.
Viewfinder	The WP indicator blinks.
Warning tone	Continues to beep until an operation is performed.
Warning description	The inserted P2 cards are write-protected.
Recording/playback operation	Recording is disabled.
Countermeasures	Disable the write-protect or replace the P2 card.

5. P2 Card Fully Recorded

Display window indication	All 7 bar indicators for remaining MEDIA capacity start blinking.
WARNING lamp	Continues to light up until an operation is performed.
Tally lamp	Continues to blink 4 times per second until an operation is performed.
Viewfinder	The END indicator blinks.
Warning tone	Continues to beep until an operation is performed.
Warning description	The P2 cards are recorded to maximum capacity.
Recording/ playback operation	The recording stops.
Countermeasures	Delete the clips in the P2 card or insert a new P2 card.

6. Recording Error

Display window indication	"00:00:00:11" appears in the time code display field. Even after recording is stopped, this display continues to blink until the next operation is performed.
WARNING lamp	Blinks 4 times per second while recording continues.
Tally lamp	Blinks 4 times per second while recording continues.
Viewfinder	The REC WARNING indicator lights up.
Warning tone	Beeps 4 times per second while recording continues.
Warning description	This indicates a failure either in the P2 card recording or the recording circuit.
Recording/ playback operation	Recording stops.
Countermeasures	Restart recording. Or, turn the power OFF and turn it ON again, before starting recording.

7. Low Wireless Signal Reception

Display window indication	No display.
WARNING lamp	Blinks 4 times per second. (During pause and recording)
Tally lamp	Blinks 4 times per second while recording continues.
Viewfinder	The WIRELESS RF indicator lights up while recording continues.
Warning tone	Beeps 4 times per second while recording continues.
Warning description	This error indicates poor wireless audio reception conditions.
Recording/ playback operation	Continues to operate without receiving the wireless microphone signal.
Countermeasures	Check the microphone power supply and the reception status of the wireless receiver.

8. 1394 (when AJ-YAD800G is attached)

Display window indication	The 1394 E-*** indicator in the display window lights up.
WARNING lamp	Blinks 4 times per second while the WARNING lamp recording is continuing.
WARNING lamp	Blinks 4 times per second while the TALLY LAMP recording is continuing.
Viewfinder	In the case of Error Code 92, "1394 INITIAL ERROR" indicator lights up (during pause and recording) For Error Codes other than Error Code 92, or if REC SIGNAL is set to "1394", no error is displayed in the viewfinder.
Warning tone	Beeps 4 times per second while ALARM recording is continuing.
Warning description	This indicates a failure of the DVCPRO/DV connector.
Recording/ playback operation	The operation continues, but input signals to the DVCPRO/DV connector are abnormal.
Countermeasures	Check the connection between the IEEE1394 cable and the DVCPRO/DV connector, settings of any external device and menus, and the turn on the power again. If the warning indication is still illuminated, confirm the "Error Codes" in the IEEE1394 interface board instruction manual, and consult your nearest service center.

9. Battery Nearly Empty

Display window indication	One of the bars in the battery remaining indicator starts blinking.
WARNING lamp	Blinks once per second.
Tally lamp	Blinks once per second.
Viewfinder	The BATT LED blinks.
Warning tone	Beeps 4 times per second.
Warning description	The battery is about to run out.
Recording/ playback operation	Continues to operate.
Countermeasures	Replace the battery as required.

10. P2 Card Nearly Full

Display window indication	One of the bars for remaining MEDIA capacity starts blinking.
WARNING lamp	Blinks once per second while recording continues.
Tally lamp	Blinks once per second while recording continues.
Viewfinder	The P2 card remaining capacity indicator blinks.
Warning tone	Beeps once per second while recording continues.
Warning description	The total remaining capacity of all the P2 cards is two minutes or less.
Recording/ playback operation	Continues to operate.
Countermeasures	Replace the cards. If there is an empty card slot, insert a new card.

7-3-2 Error Codes

The following error codes are displayed in the display window if an error occurs in the camera:

Code No.	Description
E-11	Video initialisation error
E-27	Recording control error
E-30	P2 card removal error
E-38	P2 streaming microcontroller error
E-3F	Microprocessor error in the camera control circuit.
E-6F	Reference signal error.

Chapter 8 Menu Description Tables

8-1 Menu Configuration

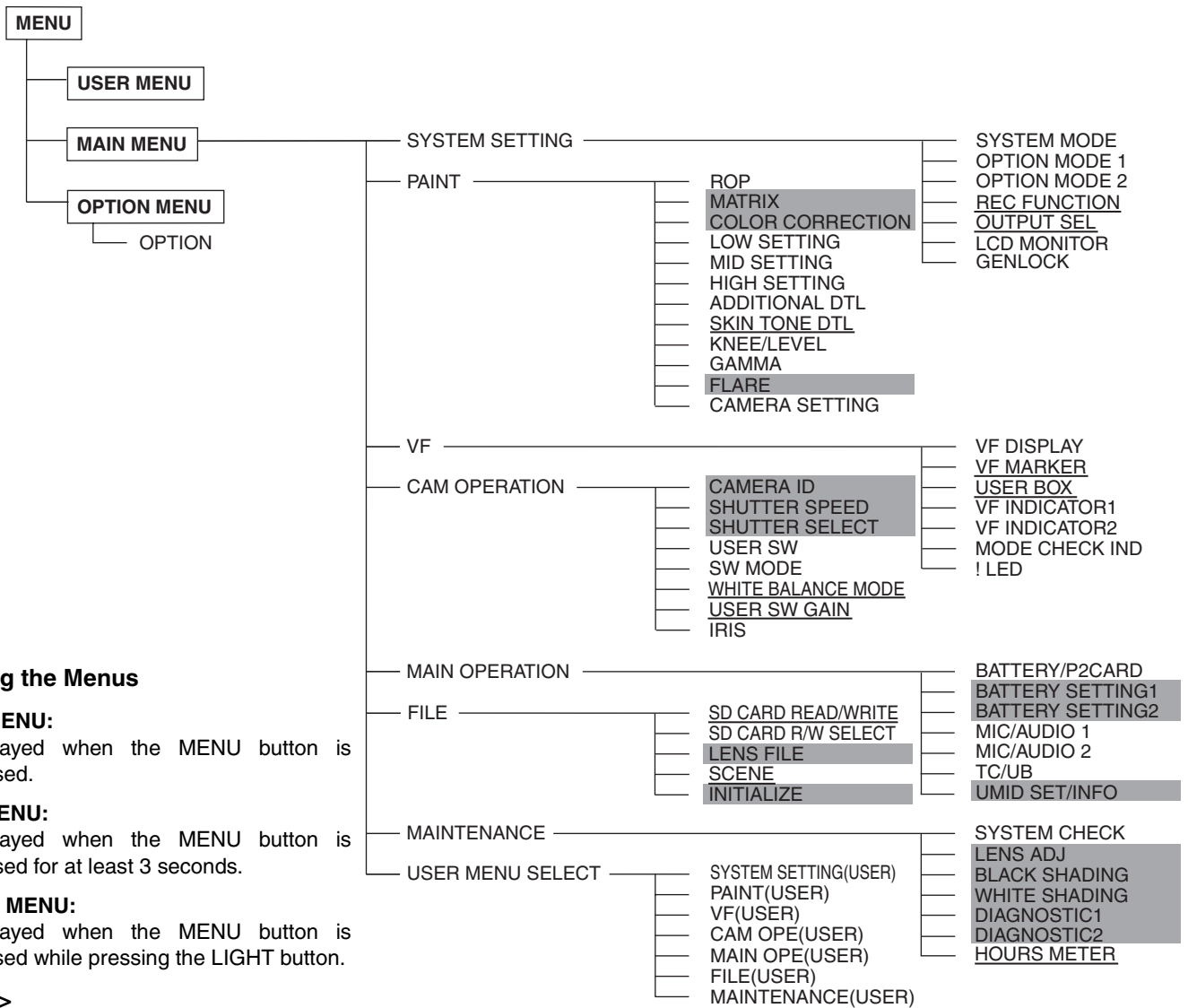

Opening the Menus

USER MENU:

Displayed when the MENU button is pressed.

MAIN MENU:

Displayed when the MENU button is pressed for at least 3 seconds.

OPTION MENU:

Displayed when the MENU button is pressed while pressing the LIGHT button.

<Notes>

- The following items can be set: 42 camera-related items (14 × 3 pages), 14 recording-related items (1 page).
- The items highlighted in grey cannot be selected by <USER MENU SELECT>.
- The underlined items can only be selected as one whole page (with all sub-items). Individual sub-items cannot be selected separately.

About Menu Description Tables

The following letters indicate whether the modified menu data is saved to or read out from the memory.

The – indicates that the data cannot be saved or read.

S = Can be saved and read as scene data file.

C = Can be saved or read using CARD READ/WRITE SD.

U = Can be saved and read as user data.

Please refer to [8-7-4 SCENE] and [8-7-5 INITIALIZE].

F = Can be read using READ FACTORY DATA.

Please refer to [8-7-5 INITIALIZE].

E = Can be saved using ECU DATA SAVE.

Please refer to [5-9 Connecting the AJ-EC3E Extension Controller].

Items/ Data Saved	Adjustable Range	Remarks
REC SIGNAL	CAM VIDEO 1394	Select video input signals. CAM: Record the signal from the camera VIDEO: Record the signal from the GENLOCK IN terminal 1394: Record the signal from the 1394 input terminal. (when optional AJ-YAD800G is attached.)
- C U F E		

This section shows the adjustable range of the set value, and available options for this item.

About the settings available for this item.

8-2 SYSTEM SETTING

8-2-1 SYSTEM MODE

Items/ Data Saved	Adjustable Range	Remarks
REC SIGNAL - C U F E	CAM VIDEO 1394	Select video input signals. CAM: Record the signal from the camera VIDEO: Record the signal from the GENLOCK IN terminal 1394: Record the signal from the 1394 input terminal (when optional AJ-YAD800G is attached.) <Notes> ● After the power has been turned OFF, this setting defaults to CAM when the power is turned ON again. ● With VIDEO selected, to synchronise this camera-recorder to the video signal (VBS) that is input to the GENLOCK IN terminal, the GENLOCK item in [8-2-7 GENLOCK] must be set to EXT.
CAMERA MODE S C U F E	50i 25P	Switch the operating mode of the camera. 50i: Camera operates in 50i mode. 25P: Camera operates in 25P mode.
V.RES (25P) S C U F E	INTRLCE PROG.	Set the vertical resolution when the 25P mode is selected. INTRLCE: Lines are mixed. Natural images can be obtained. PROG. : Lines are not mixed. Complete progressive images can be obtained when images are edited after shooting. <Note> When PROG. is selected, images are recorded as progressive segmented frame images, which enables complete progressive editing. However, adding Vertical Detail (V.DTL) produces unnatural images. Therefore, we recommend using the camera with V.DTL set to 0. (Sufficient vertical response is maintained in the images after the progressive editing even when V.DTL is set to 0.)
ASPECT - C U F E	16:9 4:3	Select the aspect ratio for recording. 16:9: Record in <16:9> aspect ratio. 4:3: Record in <4:3> aspect ratio.
REC MODE - C U F E	50M 25M DV	Select the recording mode. 50M: Record in DVCPRO50 format. 25M: Record in DVCPRO format. DV: Record in DV format.
REC TALLY - C U F E	RED GREEN CHAR	Selects display of the recording status of the camera when the AJ-SPX900E is used with a 26-pin extender or Triax, or when it is controlling an external VTR, by setting the menu option 26PIN CONTROL to "BOTH". The menu option 26PIN CONTROL is found in the OPTION MODE 2 screen on the SYSTEM SETTING page. RED: The red tally lamp lights up. GREEN: The green tally lamp lights up. CHAR: The VF displays [REC] in characters.
ACCESS LED - C U F E	ON OFF	Select whether or not to enable illumination of the P2 card access LEDs. ON: Enable the P2 card access LEDs to light up for card status indications. OFF: LEDs remain off.

Items/ Data Saved	Adjustable Range	Remarks
USB - - U F -	ON OFF	Select the USB drive mode when using the P2 card as bulk storage by connecting the AJ-SPX900E with a PC via USB2.0. ON: Switches to the USB drive mode. Recording, playback or thumbnail operation via the AJ-SPX900E is not permitted. OFF: Stops the USB drive mode, and returns to normal operation. <Note> After the power is turned off, this setting defaults to "OFF" when the power is next turned on.

8-2-2 OPTION MODE 1

Items/ Data Saved	Adjustable Range	Remarks
P.OFF GPS DATA - C U F -	HOLD CLEAR	Select whether or not to hold the UMID GPS position information while the power is turned off, thereby keeping this information as status data holding the previous value until the power is turned on again, which enables a new measurement to start. HOLD: Hold and save the data. CLEAR: Clear the data when the power is turned off, and save zero (No-Info) from the next power-on until a new measurement is completed.
SDI METADATA - C U F -	ON OFF	Select whether or not to output metadata (UMID) to the SDI (when the optional AJ-YA902AG is attached).
SDI EDH - C U F -	ON OFF	Select whether or not to add an error detection flag to the SDI output (when the optional AJ-YA902AG is attached).
SAVE SW (AUD OUT) - C U F -	ON OFF	Select whether or not to forcibly disable the audio output when the SAVE ON/OFF switch is set to [ON]. ON: Disable audio output. OFF: Enable audio output.
SAVE SW (LCD) - C U F -	ON OFF	Select whether or not to automatically turn off the LCD monitor when the SAVE ON/OFF switch is set to [ON]. ON: Turn off LCD monitor. OFF: Do not turn off LCD monitor.
SAVE SW (SDI) - C U F -	ON OFF	Select whether or not to automatically disable the SDI output when the SAVE ON/OFF switch is set to [ON]. ON: Disable SDI output. OFF: Enable SDI output.

<Note>

Menu options for setting 1394 are displayed when an IEEE1394 interface board (AJ-YAD800G, optional) is attached. For more information, see the AJ-YAD800G instruction manual.

The ____ in the Adjustable Range column indicates the preset mode.

8-2-3 OPTION MODE 2

Items/ Data Saved	Adjustable Range	Remarks
COMPONENT OUT	OFF BETACAM M2	Sets the analog component output level to Triax, 26-pin extender, or external VTR. OFF: Saves power and stops output. However, when either a 26-pin extender, external VTR or Triax is connected, output automatically switches to BETACAM level. BETACAM: Output using β -CAM level. M2: Output using M2 level.
- C U F -		
26PIN CONTROL	OFF BOTH	Sets the recording control between the external VTR and the AJ-SPX900E when a 26-pin camera adapter (AJ-CA905G, optional) is attached and used with an external VTR. OFF: Recording is performed only with the AJ-SPX900E, and not with the external VTR. BOTH: Recording is performed with both the AJ-SPX900E, and an external VTR. <Note> The Tally Lamp indicates external VTR status. Recording status of the AJ-SPX900E can be selected in the menu option REC TALLY of SYSTEM MODE.
- C U F -		
26PIN CONTROL DEFAULT	NORMAL SPECIAL	Sets the type of VTR control signal (start/stop recording) which is output from No. 12 of the 26-pin connector when the 26-pin camera adapter (AJ-CA905G, optional) is attached and controls an external VTR. NORMAL: Recording stop "LOW", recording start "HIGH". SPECIAL: Recording stop "HIGH", recording start "LOW".
- C U F -		

8-2-4 REC FUNCTION

Items/ Data Saved	Adjustable Range	Remarks
INTERVAL REC MODE	ON ONE SHOT OFF	Sets INTERVAL REC function. ON: Uses internal memory to perform interval recording. ONE SHOT: Performs "one-shot" recording for the duration specified under REC TIME, and then stops. OFF: INTERVAL REC is not performed. <Note> After the power is turned off, this setting defaults to OFF when the power is next turned on.
- - - F -		
REC TIME	00s01f : 59s24f	Set REC TIME (1 cut).
- C U F -		
PAUSE TIME	00h00m00s01f : 00h04m59s24f : 23h59m59s24f	Specify PAUSE time for recording.
- C U F -		
TAKE TOTAL TIME	NONE : 5day	Specify the time needed for shooting. Select from NONE (continue until operation is manually stopped) to 5 days.
- C U F -		
TOTAL REC TIME	00m00s01f : 99m59s24f OVER100min NONE	Display total recorded time. The setting cannot be changed using this option. Displays the recording time (recording time needed for the P2 card) calculated using REC TIME, PAUSE TIME, and TAKE TOTAL TIME.
- - - - -		
AUDIO REC	ON OFF	Select whether or not sound will be recorded.
- C U F -		
START DELAY	0SEC : 10SEC	Set the delay after pressing REC START to start recording in INTERVAL REC.
- C U F -		
PRE REC TIME	0SEC : 15SEC	Set PRE RECORDING. 0-15SEC: Set the length of time that can be retrospectively recorded before the REC START button is pressed. <Note> The maximum selectable range is 8 seconds when the REC MODE in the <SYSTEM MODE> screen is set to 50M (DVCPRO50).
- C U F -		
LOOP REC MODE	ON OFF	Select whether or not to enable LOOP REC. This setting can be used with PRE RECORDING features. ON: Enable LOOP REC. OFF: Disable LOOP REC. <Note> After the power is turned off, this item will default to OFF the next time the power is turned on.
- - - F -		

The ____ in the Adjustable Range column indicates the preset mode.

8-2-5 OUTPUT SEL

Items/ Data Saved	Adjustable Range	Remarks
VOICE MEMO RESERV	ON OFF	Set the available memory space for voice memos in P2 cards. ON: Reserve a voice memo area of 10 minutes or longer separately from the video recording capacity. The voice memo area can be used even when FULL is displayed for the recording capacity of the P2 card. OFF: Do not reserve any voice memo space. <Note> Even when this item is set to OFF, and FULL is displayed for the P2 card's recording capacity, it may be possible to record voice memos depending on the status of the P2 card.
- C U F -		
REC START	ALL NORMAL	Select operating modes that allow recording to start. ALL: Allow recording to start during stop, recording pause, and playback. NORMAL: Allow recording to start during stop and recording pause. <Note> When the INTERVAL REC MODE is set to either "ON" or "ONE SHOT", the "ALL" setting for this option switches to "NORMAL" operation.
- C U F -		
P.ON REC SLOT SEL	HOLD SLOT1	Select the recording order of the slot when the power is turned on. HOLD: The recording order starts with the card previously selected when the power was turned off. SLOT1: The recording order starts with the card that is inserted in Slot 1 when the power is turned on.
- C U F -		

Items/ Data Saved	Adjustable Range	Remarks
VIDEO OUT SEL	VBS VF Y SDI	Select the output signal on the VIDEO OUT terminal. VBS: Output a regular composite signal. VF: Output a VF Y signal. The status display is also superimposed. Y: Output a component Y signal. SDI: Output an SDI signal. Only selectable when the optional AJ-YA902AG extension board is attached.
- C U F -		
OUTPUT CHAR	TC STATUS MENU ONLY	Set the character contents superimposed onto the output signals for the VIDEO OUT terminal (Analog or SDI) and MON OUT terminal. TC: Display the time code. (Displays the menu when menu characters are superimposed.) <Note> The TC display position moves up and down depending on the camera ID position. STATUS: Display the same characters superimposed on the VF signal. (Displays the menu when menu characters are superimposed.) MENU ONLY: Displays only when the menu characters are superimposed. No display appears when other characters are superimposed.
- C U F -		
MONITOR OUT CHAR	ON OFF	Select whether or not to superimpose characters on the MON OUT terminal signal independently of the camera's VIDEO OUT CHARACTER switch. (The character content is the same as the video output signal.) ON: Enable superimpose. OFF: Disable superimpose.
- C U F -		
LCD MON CHAR	ON OFF	Select whether or not to superimpose characters on the LCD monitor. (The character content is the same as the video output signal.) ON: Enable superimpose. (Not interlocked with the VIDEO OUT CHARACTER switch.) OFF: Disable superimpose. (Not interlocked with the VIDEO OUT CHARACTER switch.)
- C U F -		
VF MODE	EE/PB EE	Select the image to display in the viewfinder. EE/PB: Display the playback image in the playback mode. EE: Always display the camera image.
- C U F -		
THUMBNAIL OUT	ON OFF	Select whether or not to output clip thumbnails displayed on the LCD monitor to the video output and monitor output signals. ON: Enable output. OFF: Disable output.
- C U F -		

The ____ in the Adjustable Range column indicates the preset mode.

8-2-6 LCD MONITOR

Items/ Data Saved	Adjustable Range	Remarks
BRIGHTNESS : +0 : - C U F - +7	-7 : +0 : +7	Adjust the LCD monitor brightness.
COLOR LEVEL : +0 : - C U F - +7	-7 : +0 : +7	Adjust the LCD monitor chroma level.
CONTRAST : +0 : - C U F - +7	-7 : +0 : +7	Adjust the LCD monitor contrast.
BACKLIGHT : - C U F -	HIGH NORMAL	Select whether or not to set the LCD monitor brightness to always high. HIGH: Set to always high. NORMAL: The brightness changes according to the BRIGHTNESS setting.
SELF SHOOT : - C U F -	NORMAL MIRROR	Select whether or not to change the LCD monitor to mirror image. NORMAL: Do not change to mirror image. MIRROR: Change to mirror image.
ASPECT CONV. : - C U F -	LT.BOX SQUEEZE	Select a screen ratio for images displayed on the LCD monitor. LT.BOX: Display images in the letter box size. SQUEEZE: Display images in the squeeze size. <Note> This item is enabled only when ASPECT described in [8-2-1 SYSTEM MODE] is set to 16:9.

8-2-7 GENLOCK

Items/ Data Saved	Adjustabl e Range	Remarks
GENLOCK : - C U F E -	INT EXT 26P EXT	Switch the camera synchronising signal. INT: Synchronise with the internal reference signal regardless of the reference signal input to the GENLOCK IN terminal. EXT: Synchronise with the reference signal input to the GENLOCK IN terminal. 26P EXT: Synchronizes to the signal input via the 26-pin connector.
H PHASE COARSE : - - - - - +50	-50 : +00 : +50	Perform coarse phase adjustment for horizontal hold when configuring a system.
H PHASE FINE : - - - - -	-160 : +000 : +160	Perform fine phase adjustment for horizontal hold when configuring a system. <Note> This adjustment simultaneously shifts the SC phase.
SC PHASE COARSE : - - - - -	0 1 : 3	Perform coarse SC PHASE adjustment when GENLOCK is set.
SC PHASE FINE : - - - - -	-75 : +00 : +75	Perform fine SC PHASE adjustment when GENLOCK is set. <Note> When adjusting GENLOCK, please adjust H PHASE first, and then adjust SC PHASE.

The ____ in the Adjustable Range column indicates the preset mode.

8-3 PAINT

8-3-1 ROP

Items/ Data Saved	Adjustable Range	Remarks
MASTER PED S C U F E	-200 : +008 : +200	Set the master pedestal level.
MASTER DTL S C U F E	-31 : +00 : +31	Set the H Detail and V Detail levels.
MASTER GAMMA S C U F E	0.35 : 0.45 : 0.75	Set MASTER GAMMA in 0.01 steps.
KNEE POINT S C U F E	70.0% : 85.0% : 107.0%	Set the KNEE POINT position in 0.5% steps.
KNEE SLOPE S C U F E	0 : 50 : 99	Set the KNEE slope.
R GAIN S C U F E	-200 : +000 : +200	Set the Rch gain.
G GAIN S C U F E	-200 : +000 : +200	Set the Gch gain.
B GAIN S C U F E	-200 : +000 : +200	Set the Bch gain.
R PEDESTAL S C U F E	-100 : +000 : +100	Set the Rch pedestal level.
G PEDESTAL S C U F E	-100 : +000 : +100	Set the Gch pedestal level.
B PEDESTAL S C U F E	-100 : +000 : +100	Set the Bch pedestal level.

<Note>

The items indicated by ■ are the setting items for PAINT MENU SW(■) R/W in the <SD CARD R/W SELECT> screen. The items without ■ are the setting items for PAINT MENU LEVEL R/W. Please refer to [8-7-2 SD CARD R/W SELECT] for more information.

8-3-2 MATRIX

Items/ Data Saved	Adjustabl e Range	Remarks
■MATRIX TABLE S C U F E	A B	Select the color correction table. 2 types of tables can be stored: type A and type B.
MATRIX R-G S C U F E	-31 : +30 : +31	Adjust the tint.
MATRIX R-B S C U F E	-31 : +05 : +31	Adjust the tint.
MATRIX G-R S C U F E	-31 : +16 : +31	Adjust the tint.
MATRIX G-B S C U F E	-31 : +19 : +31	Adjust the tint.
MATRIX B-R S C U F E	-31 : +16 : +31	Adjust the tint.
MATRIX B-G S C U F E	-31 : +05 : +31	Adjust the tint.
■MATRIX TABLE S C U F E	OFF A B	Select the color correction table to be applied to the selected GAIN switch (L/M/H).

The ____ in the Adjustable Range column indicates the preset mode.

8-3-3 COLOR CORRECTION

Items/ Data Saved	Adjustable Range	Remarks
R (SAT/PHASE)	-63 : +00 : +63	Perform red color correction (saturation and hue).
S C U F E		
R-Mg (SAT/PHASE)	-63 : +00 : +63	Perform color correction (saturation and hue) between red and magenta.
S C U F E		
Mg (SAT/PHASE)	-63 : +00 : +63	Perform magenta color correction (saturation and hue).
S C U F E		
Mg-B (SAT/PHASE)	-63 : +00 : +63	Perform color correction (saturation and hue) between magenta and blue.
S C U F E		
B (SAT/PHASE)	-63 : +00 : +63	Perform blue color correction (saturation and hue).
S C U F E		
B-Cy (SAT/PHASE)	-63 : +00 : +63	Perform color correction (saturation and hue) between blue and cyan.
S C U F E		
Cy (SAT/PHASE)	-63 : +00 : +63	Perform cyan color correction (saturation and hue).
S C U F E		
Cy-G (SAT/PHASE)	-63 : +00 : +63	Perform color correction (saturation and hue) between cyan and green.
S C U F E		
G (SAT/PHASE)	-63 : +00 : +63	Perform green color correction (saturation, hue).
S C U F E		
G-YI (SAT/PHASE)	-63 : +00 : +63	Perform color correction (saturation, hue) between green and yellow.
S C U F E		
YI (SAT/PHASE)	-63 : +00 : +63	Perform yellow color correction (saturation, hue).
S C U F E		
YI-R (SAT/PHASE)	-63 : +00 : +63	Perform color correction (saturation, hue) between yellow and red.
S C U F E		
■COLOR CORRECT	ON OFF	Select whether or not to enable color correction for the selected GAIN switch (L/M/H). ON: Enable correction. OFF: Disable correction.
S C U F E		

<Note>

The items indicated by ■ are the setting items for PAINT MENU SW(■) R/W in the <SD CARD R/W SELECT> screen. The items without ■ are the setting items for PAINT MENU LEVEL R/W. Please refer to [8-7-2 SD CARD R/W SELECT] for more information.

8-3-4 LOW SETTING

Items/ Data Saved	Adjustable Range	Remarks
■MASTER GAIN	-3dB : 0dB : 30dB	Select the master gain from -3, 0, 3, 6, 9, 12, 15, 18, 21, 24, 27, or 30dB.
S C U F E		
H.DTL LEVEL	00 : 17 : 63	Set H.DTL LEVEL.
S C U F E		
V.DTL LEVEL	00 : 24 : 31	Set V.DTL LEVEL.
S C U F E		
DTL CORING	00 : 02 : 15	Set DTL CORING.
S C U F E		
H.DTL FREQ.	00 : 20 : 31	Set a frequency (DTL width) at which H.DTL is added. The greater the value, the higher the frequency (the narrower the DTL).
S C U F E		
LEVEL DEPEND.	0 1 5	Set LEVEL DEPEND. No DTL is added to the portion whose brightness is the setting value or less. When the GAMMA MODE SEL item is set to STD, each setting value represents brightness levels, as follows: 0 = about 0%, 1 = about 4%, 2 = about 8%, 3 = about 12%, 4 = about 16%, 5 = about 20%.
S C U F E		
MASTER GAMMA	0.35 : 0.45 : 0.75	Set MASTER GAMMA in 0.01 steps.
S C U F E		
BLACK STRETCH	-3 : OFF : +3	Set the gamma curb for dark spots.
S C U F E		
■MATRIX TABLE	OFF A B	Select the color correction table.
S C U F E		
■COLOR CORRECT	ON OFF	Set the color correction to ON or OFF.
S C U F E		

The ____ in the Adjustable Range column indicates the preset mode.

8-3-5 MID SETTING

Items/ Data Saved	Adjustable Range	Remarks
■MASTER GAIN	-3dB : 9dB : 30dB	Select the master gain from -3, 0, 3, 6, 9, 12, 15, 18, 21, 24, 27, or 30dB.
S C U F E		
H.DTL LEVEL	00 : 14 : 63	Set H.DTL LEVEL.
S C U F E		
V.DTL LEVEL	00 : 20 : 31	Set V.DTL LEVEL.
S C U F E		
DTL CORING	00 : 03 : 15	Set DTL CORING.
S C U F E		
H.DTL FREQ.	00 : 20 : 31	Set a frequency (DTL width) at which H.DTL is added. The greater the value, the higher the frequency (the narrower the DTL).
S C U F E		
LEVEL DEPEND.)	0 1 : 5	Set LEVEL DEPEND. No DTL is added to the portion whose brightness is the setting value or less. When the GAMMA MODE SEL item is set to STD, each setting value represents brightness levels, as follows: 0 = about 0%, 1 = about 4%, 2 = about 8%, 3 = about 12%, 4 = about 16%, 5 = about 20%.
S C U F E		
MASTER GAMMA	0.35 : 0.45 : 0.75	Set MASTER GAMMA in 0.01 steps.
S C U F E		
BLACK STRETCH	-3 : OFF : +3	Set the gamma curb for dark spots.
S C U F E		
■MATRIX TABLE	OFF A : B	Select the color correction table.
S C U F E		
■COLOR CORRECT	ON OFF	Set the color correction to ON or OFF.
S C U F E		

<Note>

The items indicated by ■ are the setting items for PAINT MENU SW(■) R/W in the <SD CARD R/W SELECT> screen. The items without ■ are the setting items for PAINT MENU LEVEL R/W. Please refer to [8-7-2 SD CARD R/W SELECT] for more information.

8-3-6 HIGH SETTING

Items/ Data Saved	Adjustable Range	Remarks
■MASTER GAIN	-3dB : 18dB : 30dB	Select the master gain from -3, 0, 3, 6, 9, 12, 15, 18, 21, 24, 27, or 30dB.
S C U F E		
H.DTL LEVEL	00 : 12 : 63	Set H.DTL.
S C U F E		
V.DTL LEVEL	00 : 17 : 31	Set V.DTL LEVEL.
S C U F E		
DTL CORING	00 : 08 : 15	Set DTL CORING.
S C U F E		
H.DTL FREQ.	00 : 20 : 31	Set a frequency (DTL width) at which H.DTL is added. The greater the value, the higher the frequency (the narrower the DTL).
S C U F E		
LEVEL DEPEND.)	0 : 3 : 5	Set LEVEL DEPEND. No DTL is added to the portion whose brightness is the setting value or less. When the GAMMA MODE SEL item is set to STD, each setting value represents brightness levels, as follows: 0 = about 0%, 1 = about 4%, 2 = about 8%, 3 = about 12%, 4 = about 16%, 5 = about 20%.
S C U F E		
MASTER GAMMA	0.35 : 0.55 : 0.75	Set MASTER GAMMA in 0.01 steps.
S C U F E		
BLACK STRETCH	-3 : OFF : +3	Set the gamma curb for dark spots.
S C U F E		
■MATRIX TABLE	OFF A : B	Select the color correction table.
S C U F E		
■COLOR CORRECT	ON OFF	Set the color correction to ON or OFF.
S C U F E		

The ____ in the Adjustable Range column indicates the preset mode.

8-3-7 ADDITIONAL DTL

Items/ Data Saved	Adjustable Range	Remarks
KNEE APE LVL	OFF 1 2 : 5	Set KNEE APE LEVEL.
S C U F E		
CHROMA DTL	OFF 1 : 5	Set the chroma detail. Detects the chroma edge and superimposes it on Y to enhance H.DTL. A greater value increases the correction.
S C U F E		
DTL GAIN(+)	-31 : +00 : +31	Adjust the detail level toward + (upwards).
S C U F E		
DTL GAIN(-)	-31 : +00 : +31	Adjust the detail level toward the - (downwards).
S C U F E		
DTL CLIP	00 : 63	Adjust the detail signal clip towards the + direction.
S C U F E		
DTL SOURCE	(R+G)/2 (G+B)/2 2G+R+B /4 (3G+R)/4 R G	Set the signal source for detail signal components.
S C U F E		
H.DTL LINE MIX	1H 2H	Set the scan line to generate the H.DTL signal.
S C U F E		
■CORNER DTL	ON OFF	ON/OFF switching for CORNER DTL mode, which enhances the resolution around the screen perimeter.
S C U F E		

<Note>

The items indicated by ■ are the setting items for PAINT MENU SW(■) R/W in the <SD CARD R/W SELECT> screen. The items without ■ are the setting items for PAINT MENU LEVEL R/W. Please refer to [8-7-2 SD CARD R/W SELECT] for more information.

The ___ in the Adjustable Range column indicates the preset mode.

8-3-8 SKIN TONE DTL

Items/ Data Saved	Adjustable Range	Remarks
■SKIN TONE DTL	ON OFF	Set the skin tone DTL to ON or OFF.
S C U F E		
■SKIN TONE ZEBRA	ON OFF	ON/OFF switching for ZEBRA within the SKIN TONE range.
S C U F E		
SKIN DTL CORING	0 : 5 : 7	Adjust the effect of SKIN TONE DTL CORING.
S C U F E		
SKIN TONE GET	— — — — —	Used when obtaining the target hue for SKIN TONE DTL. Align the center marker and the target object with each other.
Y MAX	000 : 190 : 255	Set the maximum value of the brightness signal to which SKIN TONE effect is enabled.
S C U F E		
Y MIN	000 : 010 : 255	Set the minimum value of the brightness signal to which the SKIN TONE effect is enabled.
S C U F E		
I CENTER	000 : 022 : 255	Set the center position on the I axis (the area where SKIN TONE is enabled).
S C U F E		
I WIDTH	000 : 010 : 255	Set the area width where SKIN TONE is enabled along the I axis above and below the I CENTER.
S C U F E		
Q WIDTH	000 : 005 : 255	Set the area width where SKIN TONE is enabled along the Q axis above and below the I CENTER.
S C U F E		
Q PHASE	-128 : +000 : +127	Set the phase in the area where SKIN TONE is enabled based on the Q axis.
S C U F E		

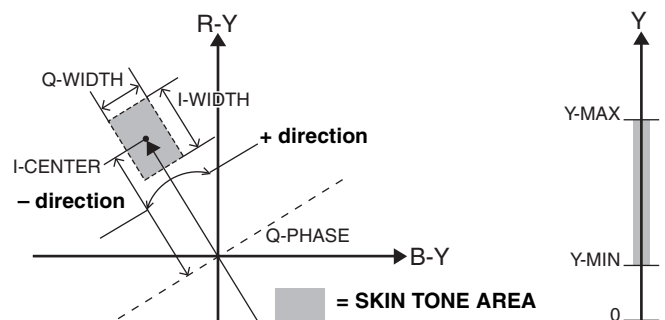

8-3-9 KNEE/LEVEL

Items/ Data Saved	Adjustable Range	Remarks
MASTER PED : : S C U F E	-200 : : +008 : : +200	Set the master pedestal.
■MANUAL KNEE : : S C U F E	ON OFF	Set the mode when the AUTO KNEE switch is OFF. The KNEE POINT/SLOPE set value is enabled when this setting is ON.
KNEE POINT : : S C U F E	70.0% : : 85.0% : : 107.0%	Set the KNEE POINT position in 0.5% steps.
KNEE SLOPE : : S C U F E	00 : : 50 : : 99 (98)	Set the KNEE SLOPE. 0 setting is equal to KNEE OFF. <Note> The adjustable range when using the AJ-EC3E is from 00 to 98.
■WHITE CLIP : : S C U F E	ON OFF	Set the WHITE CLIP feature to ON or OFF. The WHITE CLIP LVL set value is enabled when this setting is ON.
WHITE CLIP LVL : : S C U F E	90% : : 105% : : 109%	Set WHITE CLIP LEVEL.
A.KNEE POINT : : S C U F E	80% : : 85% : : 107%	Set the AUTO KNEE POINT position in 0.5% steps. This setting is enabled when the OUTPUT/AUTO KNEE selector switch is set to CAM.AUTO KNEE ON.
A.KNEE LVL : : S C U F E	100 : : 105 : : 109	Set the AUTO KNEE LEVEL.
A.KNEE RESPONSE : : S C U F E	1 : : 4	Set the AUTO KNEE response speed. The smaller the setting value, the faster the response speed.

<Note>

The items indicated by ■ are the setting items for PAINT MENU SW(■) R/W in the <SD CARD R/W SELECT> screen. The items without ■ are the setting items for PAINT MENU LEVEL R/W. Please refer to [8-7-2 SD CARD R/W SELECT] for more information.

8-3-10 GAMMA

Items/ Data Saved	Adjustable Range	Remarks
MASTER GAMMA : : S C U F E	0.35 : : 0.45 : : 0.75	Set the master gamma in 0.01% steps.
R GAMMA : : S C U F E	-15 : : +00 : : +15	Set the Rch gamma.
B GAMMA : : S C U F E	-15 : : +00 : : +15	Set the Bch gamma.
GAMMA MODE SEL	STD NEWS FILM LIKE1 FILM LIKE2	Select the gamma. STD: Standard gamma feature. NEWS: This video gamma feature can effectively reproduce gradations by reducing whiteouts and blackouts when shooting an object with partially highlighted areas. This gamma is especially effective in the AUTO KNEE mode. FILM LIKE1: Cinema gamma feature for video. This gamma is set with scene file 4 as the factory setting. FILM LIKE2: Cinema gamma feature for video. This gamma feature can reproduce gradations in highlighted areas better than FILM LIKE1 gamma. <Notes> ● Selecting NEWS gamma disables settings under the items KNEE SLOPE, KNEE POINT, and A.KNEE POINT outlined in [8-3-9 KNEE/LEVEL]. These settings are also disabled when NEWS gamma is selected with the USER switch. ● When FILELIKE1 or FILELIKE2 is selected, little change occurs and a certain curve is maintained when the setting value for the KNEE SLOPE item in [8-3-9 KNEE/LEVEL] is 00 to 50.
S C U F E		

8-3-11 FLARE

Items/ Data Saved	Adjustable Range	Remarks
R FLARE : : S C U F E	000 : : 100	Set the R FLARE.
G FLARE : : S C U F E	000 : : 100	Set the G FLARE.
B FLARE : : S C U F E	000 : : 100	Set the B FLARE.

8-4 VF

8-3-12 ■CAMERA SETTING

Items/ Data Saved	Adjustable Range	Remarks
DETAIL	ON OFF	Set the DTL (H, V) to ON or OFF.
S C U F E		
2D LPF	ON OFF	ON/OFF switching for the two-dimensional LPF that reduces cross-color.
S C U F E		
HIGH COLOR	ON OFF	ON/OFF switching for the HIGH COLOR mode, which enhances the color dynamic range.
S C U F E		
GAMMA	ON OFF	Set the gamma circuit to ON or OFF.
S C U F E		
TEST SAW	ON OFF	Switch the test signal ON or OFF.
S C U F E		
FLARE	ON OFF	Set the flare correction to ON or OFF.
S C U F E		
H-F COMPE.	ON OFF	ON/OFF switching for the H-F COMPE mode, which enhances the DTL in the high-frequency range.
S C U F E		

ZEBRA Pattern Display

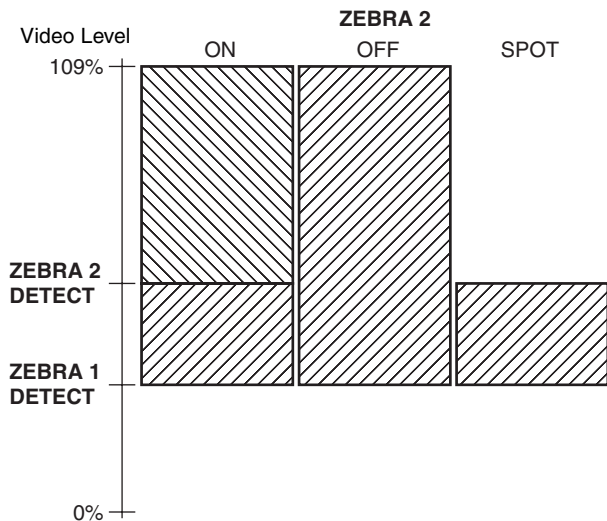

<Note>

All items in CAMERA SETTING are setting targets of the item PAINT MENU SW(■) R/W in the <SD CARD R/W SELECT> screen.

8-4-1 VF DISPLAY

Items/ Data Saved	Adjustable Range	Remarks
DISP CONDITION	NORMAL HOLD	NORMAL: Display status constantly. HOLD: Display status only when the MODE CHECK switch is pressed.
- C U F E		
DISP MODE	1 2 3	Set the DISP MODE. Switch the camera's Warning/Message indication. Please refer to [4-7-4 Display Modes and Setting Changes/adjustment Result Messages] for more information.
- C U F E		
VF OUT	Y NAM R G B	Select the VF output. Y: Brightness signal NAM: Output signal with the highest level among R, G, and B signals. R: Rch signal G: Gch signal B: Bch signal
- C U F E		
VF DTL	0 : 3 : 5	Select the VF DTL. Additionally enhance the DTL for the VF signal. 0 setting is the same DTL as the primary scan lines.
- C U F E		
ZEBRA1 DETECT	0% : 70% : 109%	Set the ZEBRA1 detection level (IRE value).
- C U F E		
ZEBRA2 DETECT	0% : 85% : 109%	Set the ZEBRA2 detection level (IRE value).
- C U F E		
ZEBRA2	ON SPOT OFF	Set the ZEBRA2 to ON, OFF, or SPOT.
- C U F E		
LOW LIGHT LVL	OFF 10% 15% 20% 25% 30% 35%	Set the camera incoming light volume at which to display LOW LIGHT.
- C U F E		
ECU MENU DISP.	ON OFF	Set the menu display on the VF to ON or OFF when the ECU is connected.
- C U F E		
50M INDICATOR	ON OFF	Set the 50M recording indication to ON or OFF.
- C U F E		
MARKER/CHAR LVL	50% 60% 70% 80% 90% 100%	Adjust the brightness of markers and characters displayed on the VF.
- C U F E		

The ____ in the Adjustable Range column indicates the preset mode.

8-4-2 VF MARKER

Items/ Data Saved	Adjustable Range	Remarks
TABLE	A B	Select the VF MARKER setting table. First, select table A or B, then set the items below for each table.
- C U F E		
CENTER MARK	OFF 1 2 3 4	Switch the center mark. OFF: Do not display center mark. 1: + (large) 2: Hollow (large) 3: + (small) 4: Hollow (small)
- C U F E		
SAFETY ZONE	OFF 1 2	Select the frame type for the safety zone. OFF: Do not display frame. 1: Box 2: Corner frame
- C U F E		
SAFETY AREA	80% : 90% : 100%	Set the position of the safety zone.
- C U F E		
FRAME SIG	4:3 13:9 14:9 VISTA	Set the frame marker. Only enabled when REC MODE is set to 16:9. The VISTA ratio is 16:8.65.
- C U F E		
FRAME MARK	ON OFF	Set the frame marker to ON or OFF.
- C U F E		
FRAME LVL	0 : 15	Set the level outside the frame marker. 0: Equivalent to signal OFF. 15: Same brightness as center area. This setting, however, is disabled if the FRAME SIG is set to VISTA.
- C U F E		

8-4-3 USER BOX

Items/ Data Saved	Adjustable Range	Remarks
USER BOX	ON OFF	Select whether or not to display the USER BOX.
- C U F E		
USER BOX WIDTH	1 : 13 : 100	Set the width of the USER BOX.
- C U F E		
USER BOX HEIGHT	1 : 13 : 144	Set the height of the USER BOX.
- C U F E		
USER BOX H POS	-50 : +00 : +50	Set the horizontal position of the USER BOX.
- C U F E		
USER BOX V POS	-144 : +000 : +144	Set the vertical position of the USER BOX.
- C U F E		

8-4-4 VF INDICATOR1

Items/ Data Saved	Adjustable Range	Remarks
EXTENDER	ON OFF	Set the extender indication to ON or OFF.
- C U F E		
SHUTTER	ON OFF	Set the shutter speed indication to ON or OFF.
- C U F E		
FILTER	ON OFF	Set the filter No. indication to ON or OFF.
- C U F E		
WHITE	ON OFF	Set the AWB PRE/A/B indication to ON or OFF.
- C U F E		
GAIN	ON OFF	Set to ON or OFF the indications for current gain setting, S.GAIN, and DS.GAIN.
- C U F E		
IRIS	OFF IRIS S+IRIS S	OFF: Disable indications of both the super iris ON status and the iris value. IRIS: Enable only the iris value indication. S+IRIS: Enables indications of the super iris ON status and the iris value. S: Enable indication of the super iris ON status. (The iris value indication and the iris override indication/non indication are interlocked.)
- C U F E		
CAMERA ID	BAR CAM ALWAYS OFF	Select when to enable the ID mix during recording. BAR: Enable when recording color bars. CAM: Enable when recording camera image. ALWAYS: Enable always. OFF: Disable ID mix.
- C U F E		
ID POSITION	UPPER R UPPER L LOWER R LOWER L	Set the camera ID recording position. UPPER R: Upper right. UPPER L: Upper left. LOWER R: Lower right. LOWER L: Lower left.
- C U F E		
DATE/TIME	ON OFF	Select whether or not to simultaneously mix the year/month/date and hour/minute/second when recording the camera ID.
- C U F E		
ZOOM LVL	ON OFF	Set the zoom position indication to ON or OFF.
- C U F E		
COLOR TEMP	ON OFF	Set the color temperature indication to ON or OFF.
- C U F E		
CAMERA MODE	ON OFF	Set the camera operation mode indication to ON or OFF.
- C U F E		

The ____ in the Adjustable Range column indicates the preset mode.

8-4-5 VF INDICATOR2

Items/ Data Saved	Adjustable Range	Remarks
P2CARD REMAIN	TOTAL ONE-CARD OFF	Select the indication mode for the P2 card's remaining capacity. TOTAL: Display the total remaining capacity of all P2 cards in slots. ONE-CARD: Display the remaining capacity of the P2 card currently used for recording. OFF: Disable the remaining capacity indication.
- C U F E		
BATTERY	ON OFF	Set the battery voltage indication to ON or OFF.
- C U F E		
AUDIO LVL	ON OFF	Set the audio level meter indication to ON or OFF.
- C U F E		
TC	TCG TCR TCG/TCR OFF	Select the time code to display. TCG: Display the time code generator value in E-E mode. TCR: Display the time code reader value in V-V mode. TCG/TCR: Display the time code generator value in E-E mode, and the time code reader value in V-V mode. OFF: Disable the time code display.
- C U F E		
SYSTEM INFO	ALWAYS NORMAL OFF	Select the method of displaying system information and warnings. ALWAYS: Always display warnings. NORMAL: Display warnings for 3 seconds only when problems occur. OFF: Display no warnings other than "TURN POWER OFF" and "SYSTEM ERROR".
- C U F E		
SAVE LED	P2CARD SAVE	Set the SAVE lamp function. P2CARD: The lamp blinks in synch with the warning message when the P2 card's remaining recording capacity is getting low. SAVE: The lamp lights up when the SAVE ON/OFF switch is set to ON and the output system assigned in [8-2-2 OPTION MODE 1] is in the save mode.
- C U F E		
DV	ON OFF	DV Select whether or not to enable DV indication when the format is set to DV. ON: Enable DV indication. OFF: Disable DV indication.
- C U F E		
VOICEMEMO	ON OFF	Select whether or not to enable the V indication during voice memo recording. ON: Enable V indication. OFF: Disable V indication.
- C U F E		

Items/ Data Saved	Adjustable Range	Remarks
REC STATUS	ON OFF	Select whether or not to enable "REC" indication in the viewfinder and on the LCD monitor during recording. ON: REC indication enabled. OFF: REC indication not enabled. <Note> This option is useful when the AJ-SPX900E is used independently. When a 26-pin extender, external VTR, or Triax is connected, settings are subject to the setting of the menu option REC TALLY in SYSTEM MODE.
- C U F E		
PROXY REC	ON OFF	When a video encoder card (AJ-YAX800G, optional) is attached, proxy recording information is displayed when recording starts. ON: Display indicating whether proxy recording is to be performed on the P2 card only, or on both the P2 card and the SD memory card. OFF: Proxy recording information is not displayed.
- C U F E		

8

8-4-6 MODE CHECK IND

Items/ Data Saved	Adjustable Range	Remarks
STATUS	ON OFF	Select whether or not to display the status indication during MODE CHECK.
- C U F E		
!LED	ON OFF	Select whether or not to display the cause indication screen when the ! LED turns on during MODE CHECK
- C U F E		
FUNCTION	ON OFF	Select whether or not to display the FUNCTION indication screen during MODE CHECK.
- C U F E		
AUDIO	ON OFF	Select whether or not to display the AUDIO indication screen during MODE CHECK.
- C U F E		
P.ON IND	ON OFF	Select whether or not to display the status indication screen after the power is turned ON.
- C U F E		

The ____ in the Adjustable Range column indicates the preset mode.

8-5 CAM OPERATION

8-4-7 !LED

Items/ Data Saved	Adjustable Range	Remarks
GAIN(0dB)	ON OFF	Select whether or not to illuminate when GAIN is set to other than 0 dB.
- C U F E		
GAIN (-3dB)	ON OFF	Select whether or not to illuminate when GAIN is set to other than -3 dB.
- C U F E		
DS.GAIN	ON OFF	Select whether or not to illuminate when DS.GAIN (storage gain) is ON.
- C U F E		
SHUTTER	ON OFF	Select whether or not to illuminate when the shutter is set to ON.
- C U F E		
WHITE PRESET	ON OFF	Select whether or not to illuminate when the WHITE BAL switch is set to PRST.
- C U F E		
EXTENDER	ON OFF	Select whether or not to illuminate when the lens is in EXTENDER mode.
- C U F E		
BLACK STR	ON OFF	Select whether or not to illuminate when BLACK STRETCH is used.
- C U F E		
MATRIX	ON OFF	Select whether or not to illuminate when MATRIX is set to ON.
- C U F E		
COLOR CORRECTION	ON OFF	Select whether or not to illuminate when COLOR CORRECTION is set to ON.
- C U F E		
FILTER	ON OFF	Select whether or not to illuminate with filter combinations other than the CC filter "B" (3200 K) and ND filter "1" (CLEAR).
- C U F E		
SUPER V	ON OFF	Select whether or not to illuminate when SUPER V is set to ON.
- C U F E		
50M/25M/DV	OFF W/O 50M W/O 25M W/O DV	Select whether or not to illuminate according to the recording mode. OFF: Does not illuminate in any recording mode. W/O 50M: Illuminate except in DVCPRO50 mode. W/O 25M: Illuminate except in DVCPRO mode. W/O DV: Illuminate except in DV mode.
- C U F E		
ATW	ON OFF	Select whether or not to illuminate when auto-tracking white balance is allocated to the WHITE BAL switch B.
- C U F E		
D.ZOOM	ON OFF	Select whether or not to illuminate during digital zoom operation.
- C U F E		

<Note>

If both GAIN (0 dB) and GAIN (-3 dB) are set to ON, the LED illuminates except when GAIN is adjusted to 0 dB and -3 dB.

8-5-1 CAMERA ID

Items/ Data Saved	Adjustable Range	Remarks
ID1		Setting 1 for the CAMERA ID recorded on color bars. Up to 10 characters are allowed for this setting.
- C U F -		
ID2		Setting 2 for the CAMERA ID recorded on color bars. Up to 10 characters are allowed for this setting.
- C U F -		
ID3		Setting 3 for the CAMERA ID recorded on color bars. Up to 10 characters are allowed for this setting.
- C U F -		

<Note>

This setting is canceled when READ FACTORY DATA is selected.

8-5-2 SHUTTER SPEED

Items/ Data Saved	Adjustable Range	Remarks
SYNCHRO SCAN	ON OFF	Allocate SYNCHRO SCAN as a shutter speed selectable by the shutter switch.
- C U F E		
SUPER V	ON OFF	Allocate SUPER V as a shutter speed selectable by the shutter switch.
- C U F E		
POSITION1	ON OFF	Allocate the shutter speed set by POSITION1 SELECT in the <SHUTTER SELECT> screen as the shutter speed selectable by the shutter switch.
- C U F E		
POSITION2	ON OFF	Allocate the shutter speed set by POSITION2 SELECT in the <SHUTTER SELECT> screen as the shutter speed selectable by the shutter switch.
- C U F E		
POSITION3	ON OFF	Allocate the shutter speed set by POSITION3 SELECT in the <SHUTTER SELECT> screen as the shutter speed selectable by the shutter switch.
- C U F E		
POSITION4	ON OFF	Allocate the shutter speed set by POSITION4 SELECT in the <SHUTTER SELECT> screen as the shutter speed selectable by the shutter switch.
- C U F E		
POSITION5	ON OFF	Allocate the shutter speed set by POSITION5 SELECT in the <SHUTTER SELECT> screen as the shutter speed selectable by the shutter switch.
- C U F E		
POSITION6	ON OFF	Allocate the shutter speed set by POSITION6 SELECT in the <SHUTTER SELECT> screen as the shutter speed selectable by the shutter switch.
- C U F E		

The ____ in the Adjustable Range column indicates the preset mode.

8-5-3 SHUTTER SELECT

Items/ Data Saved	Adjustable Range	Remarks
SUPER V MODE	FRM1 FRM2	Select the SUPER V switching mode. FRM1 : Normal mode. FRM2 : After-image reduction mode. <Note> The SUPER V mode increases vertical resolution by directly outputting the photo-diode vertical signal from the CCD. FRM1 sets the accumulation level to 1/25th second. FRM sets the level to 1/50th second, reducing sensitivity by half.
- C U F E		
POSITION1 SEL	1/60 1/120 1/250 1/500 1/1000 1/2000	Select the shutter speed to be allocated to POSITION1.
- C U F E		
POSITION2 SEL	1/60 1/120 1/250 1/500 1/1000 1/2000	Select the shutter speed to be allocated to POSITION2.
- C U F E		
POSITION3 SEL	1/60 1/120 1/250 1/500 1/1000 1/2000	Select the shutter speed to be allocated to POSITION3.
- C U F E		
POSITION4 SEL	1/60 1/120 1/250 1/500 1/1000 1/2000	Select the shutter speed to be allocated to POSITION4.
- C U F E		
POSITION5 SEL	1/60 1/120 1/250 1/500 1/1000 1/2000	Select the shutter speed to be allocated to POSITION5.
- C U F E		
POSITION6 SEL	1/60 1/120 1/250 1/500 1/1000 1/2000	Select the shutter speed to be allocated to POSITION6.
- C U F E		

8-5-4 USER SW

Items/ Data Saved	Adjustable Range	Remarks
USER MAIN SW	INH S.GAIN DS.GAIN S.IRIS I.OVR S.BLK B.STR D.ZOOM ATW Y GET NEWS-G. AUDIO CH1 AUDIO CH2 REC SW RET SW SLOT SEL	Allocate the USER MAIN button.
- C U F E		
USER1 SW	INH S.GAIN DS.GAIN S.IRIS I.OVR S.BLK B.STR D.ZOOM ATW Y GET NEWS-G. AUDIO CH1 AUDIO CH2 REC SW RET SW SLOT SEL	Allocate the USER1 button.
- C U F E		
USER2 SW	INH S.GAIN DS.GAIN S.IRIS I.OVR S.BLK B.STR D.ZOOM ATW Y GET NEWS-G. AUDIO CH1 AUDIO CH2 REC SW RET SW SLOT SEL	Allocate the USER2 button.
- C U F E		

<Note>

For each function of the USER switches, refer to [4-9-4 Assigning Functions to USER MAIN, USER1 and USER2 Buttons].

The ____ in the Adjustable Range column indicates the preset mode.

8-5-5 SW MODE

Items/ Data Saved	Adjustable Range	Remarks
RET SW	REC <u>CHECK</u> CAM RET	Select the RET switch function. REC CHECK: Perform REC REVIEW. CAM RET: Perform return signal output.
- C U F E		
S.BLK LVL	OFF -10 -20 -30	Set the super black level.
- C U F E		
AUTO KNEE SW	ON OFF	Select whether or not to use the AUTO KNEE switch.
S C U F E		
SHD,ABB SW CTL	ON OFF	Select whether or not to enable the automatic black shading adjustment if the ABB switch has been pressed for 5 seconds or more.
- C U F E		
COLOR BARS	SMPTE FULL BARS SPLIT ARIB	Select the color bars to use. SMPTE: Use the SMPTE color bars. FULL BARS: Use full color bars. SPLIT: Use SPLIT color bars. ARIB: Use ARIB multi-format color bars.
- C U F E		
S.GAIN OFF	L/M/H S.GAIN	Select when the SUPER GAIN mode is disabled. L/M/H: Disabled when the gain selector switch is operated. S.GAIN: Disabled only with the S.GAIN switch (USER button).
- C U F E		
DS.GAIN OFF	L/M/H DS.GAIN	Select when the DIGITAL SUPER GAIN mode (stored gain) is disabled. L/M/H: Disabled when the gain selector switch is operated. DS.GAIN: Disabled only with the DS.GAIN switch (USER button).
- C U F E		
ECU DATA SAVE	ON OFF	ON: Store the values set and adjusted with the ECU when the ECU is disconnected from the camera-recorder. OFF: Does not store camera-related set values.
- C U F -		
ECU REC CHK SW	R.REVIEW PLAY	Select the camera-recorder operation to be performed when the ECU REC CHECK button is pressed. R.REVIEW: Perform REC REVIEW. PLAY: Play back the most-recently recorded clip from the beginning.
- C U F E		

8-5-6 WHITE BALANCE MODE

Items/ Data Saved	Adjustable Range	Remarks
FILTER INH	ON OFF	Select whether or not to retain white balance memory (A/B) data for individual CC filters. ON: Retain data in the A/B memory (2 memory areas) regardless of the CC filters. OFF: Retain data for individual CC filters.
- C U F E		
SHOCKLESS AWB	OFF FAST NORMAL SLOW1 SLOW2 SLOW3	Set SHOCKLESS AWB to ON (FAST/NORMAL/SLOW1-3) or OFF. SHOCKLESS AWB eliminates the shock caused by switching the WHITE BAL switch's PRST/A/B setting. The switching time can also be selected.
- C U F E		
AWB AREA	25% 50% 90%	Switch the AWB detection area. 25%: Detect 25% of area around the screen center. 50%: Detect 50% of area around the screen center. 90%: Detect 90% of area in the full screen.
- C U F E		
AWB & ABB OFFSET	ON OFF	Select whether or not to reset the GAIN and PED values in the ROP menu when AWB and ABB are executed. ON: Do not reset. OFF: Reset values.
- C U F E		
COLOR TEMP PRE	3200K : 5600K	Set the AWB PRE color temperature.
- C U F E		
AWB A	MEM VAR	Select the function to be allocated to WHITE BAL switch A. MEM: Function to store values set by executing the auto white balance. VAR: Function to apply color temperature set by COLOR TEMP A.
- C U F E		
COLOR TEMP A	3200K : 5600K	Set the color temperature when VAR is selected under AWB A.
- C U F E		
AWB B	MEM ATW VAR	Select the function to be allocated to WHITE BAL switch B. MEM: Function to store values set by executing auto white balance. ATW: Function to execute auto-tracking white balance. VAR: Function to apply color temperature set by COLOR TEMP B.
- C U F E		
COLOR TEMP B	3200K : 5600K	Set the color temperature when VAR is selected under AWB B.
- C U F E		
ATW SPEED	NORMAL SLOW FAST	Select the control speed for the auto-tracking white balance.
- C U F E		

The ____ in the Adjustable Range column indicates the preset mode.

8-5-7 USER SW GAIN

Items/ Data Saved	Adjustable Range	Remarks
S.GAIN 30 dB	* •	Select whether or not to enable 30dB for SUPER GAIN. *: Enable. •: Disable.
- C U F E		
36 dB	* •	Select whether or not to enable 36dB for SUPER GAIN. *: Enable. •: Disable.
- C U F E		
42 dB	* •	Select whether or not to enable 42dB for SUPER GAIN. *: Enable. •: Disable.
- C U F E		
48 dB	* •	Select whether or not to enable 48dB for SUPER GAIN. *: Enable. •: Disable.
- C U F E		
DS.GAIN 6 dB ↑ (1/25)	* •	Select whether or not to enable 6 dB ↑ (1/25) for DS.GAIN. *: Enable. •: Disable.
- C U F E		
12 dB ↑ (1/12)	* •	Select whether or not to enable 12 dB ↑ (1/12) for DS.GAIN. *: Enable. •: Disable.
- C U F E		
20 dB ↑ (1/5)	* •	Select whether or not to enable 20 dB ↑ (1/5) for DS.GAIN. *: Enable. •: Disable.
- C U F E		

8-5-8 IRIS

Items/ Data Saved	Adjustable Range	Remarks
A.IRIS LEVEL	000 : 050 : 100	Set the target value for auto iris.
- C U F E		
A.IRIS PEAK/ AVE	000 : 040 : 100	Determine the peak-to-standard ratio for the auto iris. A larger value sets the auto iris to respond to the peak in the IRIS detection window, while a smaller value sets it to respond to the average value in the window.
- C U F E		
A.IRIS MODE	NORM1 NORM2 CENTR	Select the auto iris detection window. NORM1: The window closer to the center of the screen. NORM2: The window closer to bottom of the screen. CENTR: The spot window in the center of the screen.
- C U F E		
S.IRIS LEVEL	000 : 080 : 100	Set the target value for the super iris.
- C U F E		
IRIS GAIN	CAM LENS	Select which unit controls IRIS GAIN. <Note> Lenses with an extender, such as ×2, ×0.8 sold before FUJINON DIGI POWER, perform IRIS compensation while enabling the extender. Therefore, if this setting is switched to CAM, the camera's iris control will not operate properly.
- C U F E		
IRIS GAIN VALUE	01 : 08 : 20	Set the adjustable value for IRIS GAIN. This setting is effective when CAM is selected for IRIS GAIN.
- C U F E		

The ____ in the Adjustable Range column indicates the preset mode.

8-6 MAIN OPERATION

8-6-1 BATTERY/P2CARD

Items/ Data Saved	Adjustable Range	Remarks
BATTERY SELECT	PRO14 TRIM14 HYTRN50 HYTRN100 HYTRN120 DIONIC90 DIONIC160 HP-90L BP-H120 NP-L50 ENDURA50 ENDURA80 BP-L60/90 NiCd14 NiCd13 NiCd12 TYPE A TYPE B	Select the battery to use. Remaining capacity detection is also performed according to the selected battery. The selectable battery types change depending on the settings under [8-6-2 BATTERY SETTING1] and [8-6-3 BATTERY SETTING2].
- C U F -		
EXT DC IN SELECT	AC_ADPT PRO14 TRIM14 HYTRN50 HYTRN100 HYTRN120 DIONIC90 DIONIC160 HP-90L BP-H120 NP-L50 ENDURA50 ENDURA80 BP-L60/90 NiCd14 NiCd13 NiCd12 TYPE A TYPE B	Set the remaining capacity detection type when a battery is connected to the DC IN connector. Remaining capacity detection is also performed according to the selected battery type. The selectable battery types change depending on the settings under [8-6-2 BATTERY SETTING1] and [8-6-3 BATTERY SETTING2]. <Note> The % display is disabled even when a digital battery is connected to the DC IN connector.
- C U F -		
BATT NEAR END ALARM	ON OFF	Select whether or not to set the alarm to beep for BATT NEAR END ALARM.
- C U F -		
BATT NEAR END CANCEL	ON OFF	If set to ON, the warning tone and indication can be canceled by pressing the MODE CHECK button when BATT NEAR END ALARM is triggered.
- C U F -		
BATT END ALARM	ON OFF	Select whether or not to set the alarm to beep for BATT END ALARM.
- C U F -		
BATT REMAIN FULL	100% 70%	Set the display content of the remaining battery capacity indicator bars in the display window when using a digital battery. 100%: Indicate FULL at 100% capacity. 70%: Indicate FULL at 70% capacity.
- C U F -		

Items/ Data Saved	Adjustable Range	Remarks
CARD NEAR END ALARM	ON OFF	Select whether or not to set the alarm to beep for P2 CARD NEAR END ALARM.
- C U F -		
CARD NEAR END TIME	3min 2min	Set the remaining time to indicate the P2 CARD NEAR END TIME alarm.
- C U F -		
CARD END ALARM	ON OFF	Select whether or not to set the alarm to beep for P2 CARD END ALARM.
- C U F -		
CARD REMAIN/ ■	5min/■ 3min/■	Set the length of time for one segment (■) of the P2 card's remaining capacity indicator bars. 5min/■: One segment represents 5 minutes. 3min/■: One segment represents 3 minutes.
- C U F -		

The ____ in the Adjustable Range column indicates the preset mode.

8-6-2 BATTERY SETTING1

Items/ Data Saved	Adjustable Range	Remarks
PRO14	* •	Enable selection under BATTERY SELECT. *: Enable selection. •: Disable selection.
	AUTO MANUAL	Select auto or manual to set the NEAR END voltage. AUTO: Set voltage automatically. MANUAL: Set voltage manually.
	11.0 : 13.7 : 15.0	When MANUAL is selected in the above menu, set the NEAR END voltage in 0.1 V steps.
- C U F -		
TRIM14	* •	Enable selection under BATTERY SELECT. *: Enable selection. •: Disable selection.
	AUTO MANUAL	Select auto or manual to set the NEAR END voltage. AUTO: Set voltage automatically. MANUAL: Set voltage manually.
	11.0 : 13.6 : 15.0	When MANUAL is selected in the menu above, set the NEAR END voltage in 0.1 V steps.
- C U F -		
HYTRON50	* •	Enable selection under BATTERY SELECT. *: Enable selection. •: Disable selection.
	AUTO MANUAL	Select auto or manual to set the NEAR END voltage. AUTO: Set voltage automatically. MANUAL: Set voltage manually.
	11.0 : 13.1 : 15.0	When MANUAL is selected in the menu above, set the NEAR END voltage in 0.1 V steps.
- C U F -		
HYTRON100	* •	Enable selection under BATTERY SELECT. *: Enable selection. •: Disable selection.
	AUTO MANUAL	Select auto or manual to set the NEAR END voltage. AUTO: Set voltage automatically. MANUAL: Set voltage manually.
	11.0 : 13.2 : 15.0	When MANUAL is selected in the menu above, set the NEAR END voltage in 0.1 V steps.
- C U F -		
HYTRON120	* •	Enable selection under BATTERY SELECT. *: Enable selection. •: Disable selection.
	AUTO MANUAL	Select auto or manual to set the NEAR END voltage. AUTO: Set voltage automatically. MANUAL: Set voltage manually.
	11.0 : 13.1 : 15.0	When MANUAL is selected in the menu above, set the NEAR END voltage in 0.1 V steps.
- C U F -		

Items/ Data Saved	Adjustable Range	Remarks
DIONIC90	* •	Enable selection under BATTERY SELECT. *: Enable selection. •: Disable selection.
	AUTO MANUAL	Select auto or manual to set the NEAR END voltage. AUTO: Set voltage automatically. MANUAL: Set voltage manually.
	11.0 : 13.6 : 15.0	When MANUAL is selected in the menu above, set the NEAR END voltage in 0.1 V steps.
- C U F -		
DIONIC160	* •	Enable selection under BATTERY SELECT. *: Enable selection. •: Disable selection.
	AUTO MANUAL	Select auto or manual to set the NEAR END voltage. AUTO: Set voltage automatically. MANUAL: Set voltage manually.
	11.0 : 13.3 : 15.0	When MANUAL is selected in the menu above, set the NEAR END voltage in 0.1 V steps.
- C U F -		
HP-90L	* •	Enable selection under BATTERY SELECT. *: Enable selection. •: Disable selection.
	AUTO MANUAL	Select auto or manual to set the NEAR END voltage. AUTO: Set voltage automatically. MANUAL: Set voltage manually.
	11.0 : 12.4 : 15.0	When MANUAL is selected in the menu above, set the NEAR END voltage in 0.1 V steps.
- C U F -		
BP-H120	* •	Enable selection under BATTERY SELECT. *: Enable selection. •: Disable selection.
	AUTO MANUAL	Select auto or manual to set the NEAR END voltage. AUTO: Set voltage automatically. MANUAL: Set voltage manually.
	11.0 : 11.5 : 15.0	When MANUAL is selected in the menu above, set the NEAR END voltage in 0.1 V steps.
- C U F -		
NP-L50	* •	Enable selection under BATTERY SELECT. *: Enable selection. •: Disable selection.
	AUTO MANUAL	Select auto or manual to set the NEAR END voltage. AUTO: Set voltage automatically. MANUAL: Set voltage manually.
	11.0 : 13.0 : 15.0	When MANUAL is selected in the menu above, set the NEAR END voltage in 0.1 V steps.
- C U F -		

The ____ in the Adjustable Range column indicates the preset mode.

8-6-3 BATTERY SETTING2

Items/ Data Saved	Adjustable Range	Remarks
ENDURA50	* •	Enable selection under BATTERY SELECT. *: Enable selection. •: Disable selection.
	AUTO MANUAL	Select auto or manual to set the NEAR END voltage. AUTO: Set voltage automatically. MANUAL: Set voltage manually.
	11.0 : 13.1 :	When MANUAL is selected in the menu above, set the NEAR END voltage in 0.1 V steps.
- C U F -	15.0	
ENDURA80	* •	Enable selection under BATTERY SELECT. *: Enable selection. •: Disable selection.
	AUTO MANUAL	Select auto or manual to set the NEAR END voltage. AUTO: Set voltage automatically. MANUAL: Set voltage manually.
	11.0 : 13.5 :	When MANUAL is selected in the menu above, set the NEAR END voltage in 0.1 V steps.
- C U F -	15.0	
BP-L60/90	* •	Enable selection under BATTERY SELECT. *: Enable selection. •: Disable selection.
	AUTO MANUAL	Select auto or manual to set the NEAR END voltage. AUTO: Set voltage automatically. MANUAL: Set voltage manually.
	11.0 : 11.2 :	When MANUAL is selected in the menu above, set the NEAR END voltage in 0.1 V steps.
- C U F -	15.0	

<Note>

The remaining battery capacity for digital batteries is displayed as % inside the viewfinder (PRO14/TRIM14/HYTRON50/HYTRON100/HYTRON120/DIONIC90/DIONIC160/NP-L50/ENDURA50/ENDURA80).

The BATT NEAR END alarm, however, is triggered according to the setting on the <BATTERY SETTING1> screen, regardless of the % indication.

Items/ Data Saved	Adjustable Range	Remarks	
NiCd14	* •	Enable selection under BATTERY SELECT. *: Enable selection. •: Disable selection.	
	NEAR END	11.0 : 13.6 : 15.0	Set the NEAR END voltage in 0.1 V steps.
	END	11.0 : 13.2 :	When MANUAL is selected in the menu above, set the END voltage in 0.1 V steps.
- C U F -	15.0		
NiCd13	* •	Enable selection under BATTERY SELECT. *: Enable selection. •: Disable selection.	
	NEAR END	11.0 : 12.7 : 15.0	Set the NEAR END voltage in 0.1 V steps.
	END	11.0 : 12.2 :	When MANUAL is selected in the menu above, set the END voltage in 0.1 V steps.
- C U F -	15.0		
NiCd12	* •	Enable selection under BATTERY SELECT. *: Enable selection. •: Disable selection.	
	NEAR END	11.0 : 11.5 : 15.0	Set the NEAR END voltage in 0.1 V steps.
	END	11.0 : 11.2 :	When MANUAL is selected in the menu above, set the END voltage in 0.1 V steps.
- C U F -	15.0		
TYPE A	* •	Enable selection under BATTERY SELECT. *: Enable selection. •: Disable selection.	
	FULL	12.0 : 15.0 : 17.0	Set the voltage to display the FULL indication in 0.1 V steps.
	NEAR END	11.0 : 13.6 : 15.0	Set the NEAR END voltage in 0.1 V steps.
END	11.0 : 13.2 :	When MANUAL is selected in the menu above, set the END voltage in 0.1 V steps.	
- C U F -	15.0		
TYPE B	* •	Enable selection under BATTERY SELECT. *: Enable selection. •: Disable selection.	
	FULL	12.0 : 13.5 : 17.0	Set the voltage to display the FULL indication in 0.1 V steps.
	NEAR END	11.0 : 11.8 : 15.0	Set the NEAR END voltage in 0.1 V steps.
END	11.0 : 11.1 :	When MANUAL is selected in the menu above, set the END voltage in 0.1 V steps.	
- C U F -	15.0		

8-6-4 MIC/AUDIO1

Items/ Data Saved	Adjustable Range	Remarks
FRONT VR CH1 - C U F -	FRONT W.L. REAR ALL OFF	Select whether or not to enable the FRONT AUDIO LEVEL control for the signal selected as the input signal to AUDIO CH1. FRONT: Only enabled when FRONT is selected. W.L.: Only enabled when WIRELESS is selected. REAR: Only enabled when REAR is selected. ALL: Enabled for any input selected. OFF: Disabled for any input selected. Recording level does not change by turning the volume control.
FRONT VR CH2 - C U F -	FRONT W.L. REAR ALL OFF	Select whether or not to enable the FRONT AUDIO LEVEL control for the signal selected as an input signal to AUDIO CH2. FRONT: Only enabled when FRONT is selected. W.L.: Only enabled when WIRELESS is selected. REAR: Only enabled when REAR is selected. ALL: Enabled for any input selected. OFF: Disabled for any input selected. Recording level does not change by turning the volume control.
MIC LOWCUT CH1 - C U F -	FRONT REAR W.L. OFF	Select the microphone low-cut filter.
MIC LOWCUT CH2 - C U F -	FRONT REAR W.L. OFF	Select the microphone low-cut filter.
MIC LOWCUT CH3 - C U F -	FRONT REAR W.L. OFF	Select the microphone low-cut filter.
MIC LOWCUT CH4 - C U F -	FRONT REAR W.L. OFF	Select the microphone low-cut filter.
LIMITER CH1 - C U F -	ON OFF	Select the limiter.
LIMITER CH2 - C U F -	ON OFF	Select the limiter.
AUTO LEVEL CH3 - C U F -	ON OFF	Select the level setting method.
AUTO LEVEL CH4 - C U F -	ON OFF	Select the level setting method.
REC CH3/CH4 - C U F -	SW CH1/2	Select the signals to be recorded in CH3 and CH4. SW: According to camera's CH3 and CH4 selector switches. CH1/2: Record same signals as CH1 and CH2.
25M REC CH SEL - C U F -	2CH 4CH	Select the audio channels to be recorded in the DVCPRO and DV formats. 2CH: Only recorded in CH1 and CH2. 4CH: Recorded in all channels from CH1 to CH4.

Items/ Data Saved	Adjustable Range	Remarks
TEST TONE - C U F -	NORMAL ALWAYS OFF CHSEL	Select the test signal. NORMAL: Output test tones to CH1/2 when the OUTPUT/AUTO KNEE selector switch is set to BARS and the AUDIO IN switch CH1 is set to FRONT. ALWAYS: Output test tones to CH1/2 when OUTPUT/AUTO KNEE selector switch is set to BARS. OFF: Disable test tone output. CHSEL: Output test tone to the channels where the AUDIO IN switch CH1 or CH2 is set to FRONT when OUTPUT/AUTO KNEE selector switch is set to BARS. The test tone is not output to CH3 and CH4.

8-6-5 MIC/AUDIO2

Items/ Data Saved	Adjustable Range	Remarks
FRONT MIC POWER - C U F -	ON OFF	Select the phantom power supply for the front microphone.
REAR MIC POWER - C U F -	ON OFF	Select the phantom power supply for the rear microphone.
AUDIO OUT - C U F -	ON OFF	Set the audio output circuit. OFF: Power-down output circuit to disable output. ON: Enable output.
MONITOR SELECT - C U F -	STEREO MIX	Select the signal format for the monitor output.
FRONT MIC LEVEL - C U F -	-40dB -50dB	Select the front microphone input level.
REAR MIC CH1 LVL - C U F -	-50dB -60dB	Select the rear microphone input level.
REAR MIC CH2 LVL - C U F -	-50dB -60dB	Select the rear microphone input level.
REAR LINE IN LVL - C U F -	0dB +4dB	Select the rear line input level.
AUDIO OUT LVL - C U F -	0dB +4dB	Select the audio output level.
HEADROOM - C U F -	18dB 20dB	Set the headroom (standard level).
WIRELESS WARN - C U F -	ON OFF	Select whether or not to enable the alarm to trigger for poor wireless receiver reception.

The ____ in the Adjustable Range column indicates the preset mode.

8-6-6 TC/UB

Items/ Data Saved	Adjustable Range	Remarks
UB MODE	USER TIME DATE EXT TCG FRM RATE REGEN	Select the user bits mode. USER: Select UB value set in the LCD section. TIME: Select local time (hours, minutes, seconds). DATE: Select local date and time (2 last digits of year, month, date, time). EXT: When "CAM" or "VIDEO" is selected in the menu option REC SIGNAL in the SYSTEM MODE screen, user's bit input to the TC IN connector is the reference. When "1394" is selected, user's bit input to the DVCPRO/DV connector is the reference. If reading fails, USER value is retained. TCG: TCG value enters UB. FRM RATE: Select same camera shooting information (frame rate, etc.) with the VAUX UB (VITC UB). REGEN: Read out value stored in the card and record value continuously.
- C U F -		
VITC UB MODE	USER/EXT TIME DATE TCG FRM RATE REGEN	Select the user bits mode for VAUX TC (VITC). USER/EXT: If UB MODE is set to EXT, the EXT value is recorded. If not, USER value set by UB is recorded. TIME: Select local time (hours, minutes, seconds). DATE: Select local date and time (2 last digits of year, month, date, time). TCG: TCG value enters UB. FRM RATE: Select same camera shooting information (frame rate, etc.) with the VAUX UB (VITC UB). REGEN: Read out value stored in card and record value continuously.
- C U F -		
TCG SET HOLD	ON OFF	ON/OFF switching for the feature that always starts recording (when the power is turned ON again) the TCG value that was set before the power is turned OFF.
- C U F -		
FIRST REC TC	REGEN PRESET	For the first recording after the power is turned on, a P2 card is inserted and then switching from this P2 card to another recording-target P2 card is performed, select whether or not to regenerate the time code as the value on the new P2 card. REGEN: For clips recorded on the recording-target P2 card, regenerate the time code as the time code of the clip that has the most recent date and time. PRESET: Use the camera-recorder's internal time code. <Note> Set the date and time accurately. For guidance on setting, see [4-5-2 Setting the Internal Clock's Date and Time].
- C U F -		

Items/ Data Saved	Adjustable Range	Remarks
P.OFF LCD DISPLAY	ON OFF	Select whether or not to display the time code setting and counter indication on the LCD monitor when the power is turned OFF. ON: Display setting and indication while the power is turned OFF. OFF: Power-down LCD monitor while camera power is turned OFF. Setting and indication disabled.
- C U F -		
TC OUT	TCG TCG/TCR	Select the time code to be output to the time code output connector. TCG: Always output time code generator value. TCG/TCR: Display time code generator value in E-E mode, and time code reader value in V-V mode.
- C U F -		

8-6-7 UMID SET/INFO

Items/ Data Saved	Adjustable Range	Remarks
COUNTRY	NO-INFO	Input the user's country. NO-INFO is displayed until the input completes.
- C U F -		
ORGANIZATION	NO-INFO	Input the user's organisation or company name. NO-INFO is displayed until the input completes.
- C U F -		
USER	NO-INFO	Input the user name. NO-INFO is displayed until the input completes.
- C U F -		
DEVICE NODE		Indicate the product ID number.
- - - - -		

<Note>

Please refer to [4-5-6 Setting UMID Information] for the UMID information setting.

The ____ in the Adjustable Range column indicates the preset mode.

8-7 FILE

8-7-1 SD CARD READ/WRITE

Items/ Data Saved	Adjustable Range	Remarks
R.SELECT - - - F -	1 : 8	Select the file number to read out.
READ - - - - -		Read out the data from the SD memory card.
W.SELECT - - - F -	1 : 8	Select the file number to write in.
WRITE - - - - -		Write the camera-recorder's menu data to the SD memory card.
CARD CONFIG - - - - -		Format the SD memory card.
TITLE READ - - - - -		Read out the title of the data recorded on the SD memory card.
TITLE1-8: - - - - -		Up to 8 letters can be set for the title name.

8-7-2 SD CARD R/W SELECT

Items/ Data Saved	Adjustable Range	Remarks
ID READ/ WRITE - - - F -	ON OFF	Select whether or not to include the CAMERA ID when reading out or writing to the SD memory card.
USER MENU SELECT R/W - - - F -	ON OFF	Select whether or not to include the FILE MENU settings when reading out or writing to the SD memory card.
SYSTEM MENU R/W - - - F -	ON OFF	Select whether or not to include the set values on the SYSTEM SETTING page when reading out or writing to the SD memory card.
PAINT MENU LEVEL R/W - - - F -	ON OFF	Select whether or not to include the adjusted values on the PAINT page when reading out or writing to the SD memory card.
PAINT MENU SW(■) R/W - - - F -	ON OFF	Select whether or not to include the set values on the PAINT MENU page when reading out or writing to the SD memory card.
VF MENU R/W - - - F -	ON OFF	Select whether or not to include the set values on the VF page when reading out or writing to the SD memory card.
CAM OPE MENU R/W - - - F -	ON OFF	Select whether or not to include the set values on the CAM OPERATION page when reading out or writing to the SD memory card.
MAIN OPE MENU R/W - - - F -	ON OFF	Select whether or not to include the set values on the MAIN OPERATION page when reading out or writing to the SD memory card.
MAINTEN MENU R/W - - - F -	ON OFF	Select whether or not to include the set values on the MAINTENANCE page when reading out or writing to the SD memory card.

8-7-3 LENS FILE

Items/ Data Saved	Adjustable Range	Remarks
FILE NO. - - - - -	1 : 8	Select the lens file number.
READ - - - - -		Read the lens file data.
WRITE - - - - -		Write the lens file data.
TITLE1-8 - - - - -		Up to 12 letters can be set for the title name.

8-7-4 SCENE

Items/ Data Saved	Adjustable Range	Remarks
READ USER DATA - - - - -		Read out the data from the user area in the memory.
SCENE SEL - - - - -	1 : 4	Select the scene file.
READ - - - - -		Read the scene file.
WRITE - - - - -		Write the scene file.
RESET - - - - -		Reset the scene file values to the initial values.
TITLE 1-3 - - - - -		Create the scene file title.
TITLE 4 - - - - -	FILMLIKE	Create the scene file title. The title, including the data, is set to FILMLIKE, both as the initial value and after resetting.

8-7-5 INITIALIZE

Items/ Data Saved	Adjustable Range	Remarks
READ FACTORY DATA - - - - -		The menu (USER MENU, MAIN MENU, OPTION MENU) values are all reset to factory settings.
WRITE USER DATA - - - - -		Save the user preference menu data in the camera's internal memory.
RESET LENS FILES - - - - -		Reset the lens file data to the factory settings.

The ____ in the Adjustable Range column indicates the preset mode.

8-8 MAINTENANCE

8-8-1 SYSTEM CHECK

Items/ Data Saved	Adjustable Range	Remarks
COLOR CHECK	ON OFF	ON/OFF switching for checking proper operation of the camera-recorder. Displays the center Y and RGB levels on the viewfinder to indicate whether the signals have been properly processed and transmitted from the optical system to the digital system.
- - - - -		

8-8-2 LENS ADJ

Items/ Data Saved	Adjustable Range	Remarks
F2.8 ADJ	ON OFF	The iris is only set to F2.8 when this item set to ON.
- - - - -		
F16 ADJ	ON OFF	The iris is only set to F16 when this item set to ON.
- - - - -		

8-8-3 BLACK SHADING

Items/ Data Saved	Adjustable Range	Remarks
CORRECT	ON OFF	ON/OFF switching for digital black shading compensation.
- C U F E		
DETECTION (DIG)	-	Execute digital black shading compensation.
- - - - -		

8-8-4 WHITE SHADING

Items/ Data Saved	Adjustable Range	Remarks
CORRECT	ON OFF	ON/OFF switching for white shading compensation.
- C U F E		
DETECTION (V SAW)	-	Execute white shading compensation.
- - - - -		

8-8-5 DIAGNOSTIC1

Items/ Data Saved	Adjustable Range	Remarks
CAMSOFT(IN)		Display the software version for the microprocessor-controlled flash.
- - - - -		
CAMSOFT (OUT)		Display the software version for the external flash.
- - - - -		
CAM TABLE		Display the table version.
- - - - -		
FONT ROM		Display the character font version.
- - - - -		
CAM DSP FPGA1		Display the program version for the FPGA (Field Programmable Gate Array) that processes camera block signals.
- - - - -		
CAM DSP FPGA2		Display the program version for the FPGA that processes camera block signals.
- - - - -		
CAM SYS FPGA		Display the program version for the FPGA that processes camera block signals.
- - - - -		
PULSE FPGA		Display the program version for the FPGA that processes the CCD scanning.
- - - - -		

The ____ in the Adjustable Range column indicates the preset mode.

8-9 OPTION MENU

8-8-6 DIAGNOSTIC2

Items/ Data Saved	Adjustable Range	Remarks
SYSCON SOFT - - - - -		Display the software version for the system control microprocessor.
LCD SOFT - - - - -		Display the software version for the LCD microprocessor.
P2CS OS - - - - -		Display the OS version for the streaming controller.
P2CS AP - - - - -		Display the application version for the streaming controller.
MSC FPGA - - - - -		Display the program version for the streaming control FPGA.
FLT FPGA - - - - -		Display the program version for the FPGA that processes recording / playback signals.
SIF FPGA - - - - -		Display the program version for the serial interface FPGA.
DIF FPGA - - - - -		Display program version for the IEEE1394 interface FPGA. (when AJ-YAD800G is attached).

8-8-7 HOURS METER

Items/ Data Saved	Adjustable Range	Remarks
OPERATION - - - - -		Display total hours the camera power has been turned ON.
LCD BACKLIGHT - - - - -		Display total hours the LCD monitor backlight power has been turned ON.
P.ON TIMES - - - - -		Display total number of times the power switch has been turned ON.

8-9-1 OPTION

Items/ Data Saved	Adjustable Range	Remarks
ENG SECURITY - C - - -	ON OFF	Select whether or not to prohibit opening the menu screen. ON: Menu screen cannot be opened. Please consult your nearest service center to release the setting. OFF: Menu screen can be opened.
P.HALF SHUT - C - - -	ON OFF	Select whether or not to enable the 1/2 shutter when the shutter is set to OFF while operating in the progressive mode. ON: Enable 1/2 shutter. OFF: Disable 1/2 shutter.
ID MIX INH - C - - -	ON OFF	Select whether or not to inhibit mixing the ID in the camera image. ON: Inhibit mixing. ID is not mixed in the camera image. OFF: Do not inhibit. Camera ID setting under VF INDCATOR1 is reflected in the camera image.
AUDIO OUT DELAY - C - - -	DELAYED THROUGH	Select whether or not to delay audio, headphone and speaker outputs. DELAYED: Delay audio output in synchronisation with video output. THROUGH: Output audio input without delay. This setting prevents echo effect between the sound source and audio output when the sound source is near the camera-recorder.

<Note>

Menu options for setting 1394 are displayed when an IEEE1394 interface board (AJ-YAD800G, optional) is attached. For more information, see the AJ-YAD800G instruction manual.

The ____ in the Adjustable Range column indicates the preset mode.

Chapter 9 Connection with external unit

9-1 26-pin Connection with Pin Extenders

By attaching the optional 26-pin camera adapter (AJ-CA905G), connection with the remote control unit AJ-RC905EN is possible using a 26-pin multi-cable, which leads to operation as a system camera.

For more information, see the instruction manuals for the AJ-CA905G and AJ-RC905EN.

<Note>

When this connection is used, the AJ-SPX900E automatically synchronizes with a 26-pin extender. (The setting of the GENLOCK menu need not be changed.)

9-2 Connection with external VTR

By attaching the 26-pin camera adapter (AJ-CA905G), an external VTR can be connected using a 26-pin cable for copying video.

By setting the menu option 26PIN CONTROL to "BOTH" starting and stopping of recording of an external TVR can be controlled, according to the recording, using the AJ-SPX900E.

The TALLY LED indicates external VTR status.

Recording status of the AJ-SPX900E can be selected according to the setting of REC TALLY. The menu option REC TALLY can be found in the <SYSTEM MODE> screen on the SYSTEM SETTING page.

9-3 Connection with Digital Triax

Attaching the optional camera adapter for Digital Triax (AJ-CA901EN) and using this in conjunction with the AJ-BS901EN, enables the AJ-SPX900E to be operated as a system camera.

It is possible to transfer video recorded by the AJ-SPX900E using a non-compressed wideband 360Mbps serial component signal to maintain high quality.

For more information, see the instruction manuals for the AJ-CA901EN and AJ-BS901EN.

The terms "camera", "camera recorder", and "AJ-SDX900" indicated in the above manuals can be replaced with "AJ-SPX900E". Exceptions:

"Menu configuration of the camera recorder" on the AJ-CA901EN instruction manual

Remote Menu Configuration

When a system is created by connecting the AJ-SPX900E with the camera adapter AJ-CA901EN for Digital Triax, the camera recorder's menu will be as follows:

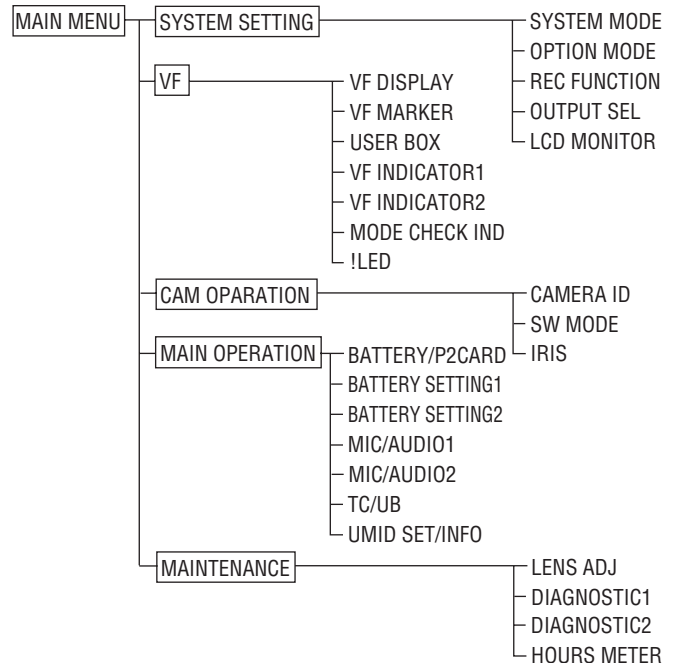

Among the menu items on the Base Station AJ-BS901EN, "NEWS" function provided with the AJ-SPX900E cannot be selected for the menu option GAMMA MODE of the FLARE/GAMMA screen. When the menu option GAMMA MODE SEL is set to "NEWS" on the AJ-SPX900E, it switches to "STD" (standard) after connecting with the AJ-BS901EN.

<Notes>

- When attaching the camera adapter AJ-CA901EN, battery-remaining level detection is based on the battery type selected in the menu option EXT DC IN SELECT. The factory-assigned default is "AC-ADPT" (AC adapter).
- When this connection is used, the AJ-SPX900E automatically synchronizes with Digital Triax. (The setting of the GENLOCK menu need not be changed.)

Chapter 10 Specifications

[General]

Power supply: DC 12 V (11.0 V - 17.0 V)

Power consumption:

24 W (Main unit only, with LCD monitor OFF)

27 W (With the SDI and IEEE1394 option installed, LCD monitor ON)

 indicates safety information.

Operating temperature:

0 °C to +40 °C

Storage temperature:

-20 °C to +60 °C

Operating humidity:

10% to maximum 85% (relative humidity)

Maximum continuous operation:

Approximately 120 minutes (main unit only, with LCD monitor OFF and using an Anton/Bauer Hytron50 battery)

Dimensions (W × H [excluding handle and wireless option cover] × D):

137 mm × 209 mm × 318 mm

Weight:

4.2 kg (main unit only, excluding VF mount)

[Camera Unit]

Pickup devices:

2/3-inch, 600,000 pixels IT CCD × 3

CC/ND Filters:

CC A: CROSS

B: 3200K

C: 4300K

D: 6300K

ND 1: CLEAR

2: 1/4ND

3: 1/16ND

4: 1/64ND

Quantizing:

14-bit linear/18 MHz

Digital signal processing:

36 MHz

Horizontal drive frequency:

18 MHz

Programmable gain:

Three positions (L/M/H) can be set by selecting from -3, 0, +3, +6, +9, +12, +15, +18, +21, +24, +27 or +30 dB

Super Gain (S.GAIN):

Selectable from +30, +36, +42 or +48 dB

Digital Super Gain (DS.GAIN):

Selectable from +6, +12 or +20 dB

Shutter speeds:

1/60, 1/120, 1/250, 1/500, 1/1000, 1/2000

Synchro-scan shutter:

1/50.4 to 1/248.0

Lens mount:

2/3-inch bayonet type

Color separation optical system:

Optical prism (F1.4)

Sensitivity:

F13 (2000 lux, 89.9% reflection)

Minimum object illuminance:

0.01 lux

(F1.4 with +48 dB (S.GAIN) and +20 dB (DS.GAIN))

Video S/N:

63 dB (standard)

Horizontal resolution:

750 lines (center, standard)

Vertical resolution:

450/500 lines (SUPER V mode)

LCD Monitor:

3.5-inch LCD color monitor, 200,000 pixels

[Memory Card Unit]

Video recording formats:

Selectable from DVCPRO50, DVCPRO and DV

Audio recording formats:

48 kHz 16-bit 4ch (DVCPRO50)

48 kHz 16-bit 2ch/4ch selectable (DVCPRO)

Recording/playback time:

Approximately 8 minutes:

When recorded in DVCPRO format using one AJ-P2C002SG card with audio signals recorded on 2 channels.

Approximately 16 minutes:

When recorded in DVCPRO format using one AJ-P2C004HG card with audio signals recorded on 2 channels.

<Note>

This recording time represents one shot continuously recorded on a P2 card. The recording time may be shorter, depending on the number of shots recorded.

Video System

Analog component output

Frequency range:

Y: 25 Hz to 5.75 MHz, +1.0/-3.0 dB (DVCPRO50)

P_B/P_R: 25 Hz to 2.75 MHz +1.0/-3.0 dB (DVCPRO50)

S/N:

Minimum 55 dB

Audio System

Sampling frequency:

48 kHz (synchronised with video)

Quantizing:

16 bits

Frequency response:

20 Hz - 20 kHz \pm 1.0 dB (at standard level)

Dynamic range:

Minimum 85 dB (1 kHz, AWTD)

Distortion factor:

0.1% or less (1 kHz, standard level)

Headroom:

18 dB

[Input/output Unit]

Video input

GEN LOCK IN:

BNC, 1.0 V_{P-P}, 75 Ω
(VIDEO IN can be selected by switching menu)

Video output

MON OUT:

BNC, 1.0 V_{P-P}, 75 Ω

VIDEO OUT:

BNC, 1.0 V_{P-P}, 75 Ω

Audio input

AUDIO IN CH1/CH2:

XLR \times 2, 3 pins
LINE, MIC, and +48 V switch-selectable
LINE: 0 dBu
(0/+4 dBu selectable with menu)
MIC: -60 dBu
(-60/-50 dBu selectable with menu)
MIC + 48V: Compatible with +48V phantom power supply
-60 dBu
(-60/-50 dBu selectable with menu)

MIC IN:

XLR, 3 pins
+48V phantom: ON/OFF selectable with menu,
3 k Ω balanced, -50/-40 dBu
selectable with menu

WIRELESS IN:

25 pin D-SUB, -40 dBu

Audio output

AUDIO OUT CH1/CH2:

XLR, 5 pins, 0 dBu
(0/+4 dBu selectable with menu)
Balanced low-impedance output

Headphones:

Stereo mini jack \times 2

Time code input

TC IN:

BNC, 0.5 V_{P-P} to 8 V_{P-P}, 10 k Ω

Time code output

TC OUT:

BNC, low impedance, 2.0 \pm 0.5 V_{P-P}

Miscellaneous

DC IN:

XLR, 4 pins, DC 12 V (DC 11 V - 17 V)

DC OUT:

4 pins, DC 12 V (DC 11 V - 17 V)
Maximum rated current: 1 A

LENS:

Multiple 12 pins

EVF:

Multiple 20 pins

GPS:

6 pins (connector for AJ-GPS900G)

ECU:

6 pins (connector for AJ-EC3E)

USB :

Type-B connector (USB ver.2.0)

DVCPRO/DV :

6-pin (IEEE1394 compatible)
(IEEE1394 interface board [AJ-YAD800G] should be attached.)

[Accessories]

Shoulder Strap

Front Audio Level control knob

Screw (M2 \times 6 mm) \times 1 pc

Weight and dimensions when shown are approximately.
Specifications are subject to change without notice.

MEMO

Panasonic Broadcast Europe
Panasonic Marketing Europe GmbH

Hagenauer Str. 43, 65203 Wiesbaden-Biebrich Deutschland Tel: 49-611-235-481

© 2005 Matsushita Electric Industrial Co., Ltd. All Rights Reserved.

