

SONY®

**SONY®**

DSR-400L/400PL/400K/400PK/450WSL/450WSPL

# Digital Camcorder

## Operating Instructions

Before operating the unit, please read this manual thoroughly and retain it for future reference.

The supplied CD-ROM includes operation manuals for the DSR-400/450WS series of digital camcorders (English, French, German, Italian, and Spanish versions). For more details, see "Using the CD-ROM Manual" on page 26.

**Power HAD EX****DVCAM**<sup>TM</sup>

**DSR-400L/400PL**  
**DSR-400K/400PK**  
**DSR-450WSL/450WSPL**



Printed on 100% recycled paper.

Sony Corporation <http://www.sony.net/>

Printed in Japan

© 2005 Sony Corporation

## Owner's Record

The model and serial numbers are located on the top. Record these numbers in the spaces provided below. Refer to them whenever you call upon your Sony dealer regarding this product.

Model No. \_\_\_\_\_ Serial No. \_\_\_\_\_

### WARNING

**To reduce the risk of fire or electric shock, do not expose this apparatus to rain or moisture.**

**To avoid electrical shock, do not open the cabinet. Refer servicing to qualified personnel only.**

### AVERTISSEMENT

**Afin de réduire les risques d'incendie ou d'électrocution, ne pas exposer cet appareil à la pluie ou à l'humidité.**

**Afin d'écartier tout risque d'électrocution, garder le coffret fermé. Ne confier l'entretien de l'appareil qu'à un personnel qualifié.**

### WARNUNG

**Um die Gefahr von Bränden oder elektrischen Schlägen zu verringern, darf dieses Gerät nicht Regen oder Feuchtigkeit ausgesetzt werden.**

**Um einen elektrischen Schlag zu vermeiden, darf das Gehäuse nicht geöffnet werden. Überlassen Sie Wartungsarbeiten stets nur qualifiziertem Fachpersonal.**

### CAUTION

Danger of explosion if battery is incorrectly replaced. Replace only with the same or equivalent type recommended by the manufacturer.

Dispose of used batteries according to the manufacturer's instructions.

### ATTENTION

Danger d'explosion si la batterie n'est pas remplacée correctement.

Remplacez-la uniquement avec le même type ou un type équivalent recommandé par le fabricant.

Disposez des batteries usagées selon les instructions du fabricant.

### VORSICHT

Explosionsgefahr bei Verwendung falscher Batterien.

Batterien nur durch den vom Hersteller empfohlenen oder einen gleichwertigen Typ ersetzen.

Verbrauchte Batterien entsprechend den Anweisungen des Herstellers entsorgen.

### For customers in the U.S.A.

This equipment has been tested and found to comply with the limits for a Class A digital device, pursuant to Part 15 of the FCC Rules. These limits are designed to provide reasonable protection against harmful interference when the equipment is operated in a commercial environment. This equipment generates, uses, and can radiate radio frequency energy and, if not installed and used in accordance with the instruction manual, may cause harmful interference to radio communications. Operation of this equipment in a residential area is likely to cause harmful interference in which case the user will be required to correct the interference at his own expense.

You are cautioned that any changes or modifications not expressly approved in this manual could void your authority to operate this equipment.

All interface cables used to connect peripherals must be shielded in order to comply with the limits for a digital device pursuant to Subpart B of Part 15 of FCC Rules.

### For the customers in the U.S.A.

This product (fluorescent lamp in the liquid crystal display) contains mercury. Disposal of this product may be regulated if sold in the United States. For disposal or recycling information, please contact your local authorities or the Electronics Industries Alliance ([www.eiae.org](http://www.eiae.org) <http://www.eiae.org>)

### For the State of California, USA only

Perchlorate Material - special handling may apply, See [www.dtsc.ca.gov/hazardouswaste/perchlorate](http://www.dtsc.ca.gov/hazardouswaste/perchlorate)  
Perchlorate Material : Lithium battery contains perchlorate.

### For the customers in Europe

This product with the CE marking complies with the EMC Directive (89/336/EEC) issued by the Commission of the European Community.

Compliance with this directive implies conformity to the following European standards:

- EN55103-1: Electromagnetic Interference (Emission)
- EN55103-2: Electromagnetic Susceptibility (Immunity)

This product is intended for use in the following Electromagnetic Environment(s):

E1 (residential), E2 (commercial and light industrial), E3 (urban outdoors) and E4 (controlled EMC environment, ex. TV studio).

### Pour les clients européens

Ce produit portant la marque CE est conforme à la Directive sur la compatibilité électromagnétique (EMC) (89/336/CEE) émise par la Commission de la Communauté européenne.

La conformité à cette directive implique la conformité aux normes européennes suivantes:

- EN55103-1: Interférences électromagnétiques (émission)
- EN55103-2: Sensibilité électromagnétique (immunité)

Ce produit est prévu pour être utilisé dans les environnements électromagnétiques suivants:

E1 (résidentiel), E2 (commercial et industrie légère), E3 (urbain extérieur) et E4 (environnement EMC contrôlé, ex. studio de télévision).

### Für Kunden in Europa

Dieses Produkt besitzt die CE-Kennzeichnung Und erfüllt die EMV-Richtlinie (89/336/EWG) der EG-Kommission.

Angewandte Normen:

- EN55103-1: Elektromagnetische Verträglichkeit (Störaussendung)
- EN55103-2: Elektromagnetische Verträglichkeit (Störfestigkeit),

für die folgenden elektromagnetischen Umgebungen: E1 (Wohnbereich), E2 (kommerzieller und in beschränktem Maße industrieller Bereich), E3 (Stadtbereich im Freien) und E4 (kontrollierter EMV-Bereich, z.B. Fernsehstudio).

### For the customers in the USA and Canada RECYCLING LITHIUM-ION BATTERIES

Lithium-Ion batteries are recyclable.

You can help preserve our environment by returning your used rechargeable batteries to the collection and recycling location nearest you.

For more information regarding recycling of rechargeable batteries, call toll free 1-800-822-8837, or visit

<http://www.rbrc.org/>



Caution: Do not handle damaged or leaking lithium-ion batteries.

### Pour les utilisateurs aux Etats-Unis et au Canada. RECYCLAGE DES ACCUMULATEURS AUX IONS DE LITHIUM

Les accumulateurs aux ions de lithium sont recyclables.

Vous pouvez contribuer à préserver l'environnement en rapportant les piles usées dans un point de collection et recyclage le plus proche.

Pour plus d'informations sur le recyclage des accumulateurs, téléphonez au numéro gratuit 1-800-822-8837 (Etats-Unis et Canada uniquement), ou visitez <http://www.rbrc.org/>



Avertissement: Ne pas utiliser des accumulateurs aux ions de lithium qui sont endommagés ou qui fuient.

### Para clientes de los EE UU y CANADÁ RECYCLADO DE BATERIAS DE IONES DE LITIO

Las baterías de iones de litio son reciclables.

Usted podrá ayudar a conservar el medio ambiente devolviendo las baterías usadas al punto de reciclaje mas cercano.

Para más información sobre el reciclado de baterías, llame al número gratuito 1-800-822-8837, o visite <http://www.rbrc.org/>



Precaución: No utilice baterías de iones de litio dañadas o con fugas.

### For the customers in Taiwan only



廢電池請回收

### Voor de Klanten in Nederland

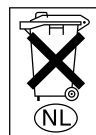

Gooi de batterij niet weg maar lever deze in als klein chemisch afval (KCA).

### Für Kunden in Deutschland

Entsorgungshinweis: Bitte werfen Sie nur entladene Batterien in die Sammelboxen beim Handel oder den Kommunen. Entladen sind Batterien in der Regel dann, wenn das Gerät abschaltet und signalisiert "Batterie leer" oder nach längerer Gebrauchsdauer der Batterien "nicht mehr einwandfrei funktioniert". Um sicherzugehen, kleben Sie die Batteriepole z.B. mit einem Klebestreifen ab oder geben Sie die Batterien einzeln in einen Plastikbeutel.

**Note about laser beams**

Laser beams can damage the CCDs of this camcorder. In environments where laser beams are used, be careful to prevent the laser beams from striking the surfaces of the CCDs.

---

# Table of Contents

Table of Contents .....	5
-------------------------	---

---

## Chapter 1 Overview

<b>Product Configurations .....</b>	<b>7</b>
<b>Features .....</b>	<b>8</b>
Camera features .....	8
VTR features.....	9
<b>Location and Function of Parts .....</b>	<b>10</b>
Front view .....	10
Right side view .....	11
Left and upper view .....	16
Rear view .....	18
Lens.....	20
DXF-801 Viewfinder.....	21
Status display on the viewfinder screen.....	22
Status display on the LCD monitor .....	24
<b>Using the CD-ROM Manual.....</b>	<b>26</b>
Preparations .....	26
Reading the CD-ROM Manual.....	26

---

## Chapter 2 Preparation

<b>Attaching and Replacing the Lithium Battery .....</b>	<b>28</b>
<b>Preparing the Lens.....</b>	<b>29</b>
Mounting the lens .....	29
Adjusting the flange focal length.....	29
<b>Preparing a Power Supply.....</b>	<b>30</b>
Using a battery pack .....	30
Using an AC adaptor .....	30
Avoiding breaks in operation due to an exhausted battery.....	31
<b>Adjusting the Viewfinder .....</b>	<b>31</b>
Fitting the viewfinder .....	31
Adjusting the viewfinder position .....	32
Adjusting the eyepiece focus and the screen (brightness, contrast, and outline emphasis).....	32
Attaching a 5-inch electronic viewfinder ...	32
<b>Using the Shoulder Strap .....</b>	<b>33</b>
<b>Adjusting the Shoulder Pad Position .....</b>	<b>33</b>

<b>Fitting to a Tripod.....</b>	<b>34</b>
<b>Using a Video Light.....</b>	<b>34</b>
<b>Preparing Audio Input System.....</b>	<b>35</b>
Using the supplied microphone .....	35
Using an external microphone .....	35
Attaching a UHF Portable Tuner (for a UHF Wireless Microphone System) .....	36
Connecting line input audio equipment.....	38
<b>Connecting the Remote Control Unit (DSR-450WS/450WSP only).....</b>	<b>38</b>

---

## Chapter 3 Connections

<b>Connecting a Monitor .....</b>	<b>41</b>
<b>Using an i.LINK Connection .....</b>	<b>42</b>
Settings required for an i.LINK connection .....	42
Making a backup of the images being recorded.....	42
Using the camcorder as a feeder .....	43
<b>Other Connections.....</b>	<b>45</b>
Connecting a number of camcorders .....	45

---

## Chapter 4 Recording and Playback

<b>Inserting a Cassette .....</b>	<b>46</b>
<b>Basic Procedure for Shooting .....</b>	<b>47</b>
<b>Recording .....</b>	<b>48</b>
Usable cassettes .....	48
Selecting the recording format.....	50
Adjusting the black balance/white balance.....	51
Setting the electronic shutter .....	53
Adjusting the iris.....	56
Adjusting the audio level.....	58
Setting the time data .....	58
Setting for special shooting cases .....	61
<b>Back Space Editing.....</b>	<b>62</b>
Starting back space editing at any tape position .....	62
Using the edit search function while back space editing.....	63
<b>Time-Lapse Video (Interval Rec).....</b>	<b>64</b>
Making settings before shooting.....	64
Shooting and recording in Interval Rec mode .....	64

<b>Recording Analog Composite Signals (with a CBK-SC01 Installed- DSR-450WS/450WSP only) .....</b>	<b>65</b>
<b>Playing and Checking Recorded Contents .....</b>	<b>66</b>
Checking the recorded contents immediately after shooting — Recording Review .....	66
Checking the recording on the color video monitor .....	66

---

## Chapter 5 Menu Displays and Detailed Settings

<b>Menu Organization and Operation.....</b>	<b>67</b>
The TOP menu.....	74
Menu list .....	76
Displaying menus .....	94
Basic menu operations.....	94
Using the USER menu (Example of the menu operation).....	95
Editing the USER menu.....	96
Resetting USER menu settings to the standard settings .....	99
<b>Setting the Status Display on the Viewfinder Screen and the LCD Monitor .....</b>	<b>99</b>
Selecting the display items .....	99
Display modes and setting change confirmation/adjustment progress messages.....	100
Setting the marker display .....	101
Setting the viewfinder.....	101
Recording shot data superimposed on the color bars .....	102
Setting the shot ID .....	102
Displaying the status confirmation windows .....	103
<b>Adjustments and Settings from Menus .....</b>	<b>104</b>
Setting gain values for the GAIN switch positions .....	104
Selecting the output signals (DSR-450WS/450WSP only).....	105
Setting the color temperature manually ....	105
Specifying an offset for the auto white balance setting .....	106

Setting the date/time of the internal clock .....	106
Assigning functions to ASSIGN switches .....	107
Selecting the lens file.....	107
Selecting the aspect ratio (DSR-450WS/450WSP only).....	107
Setting the CCD scan mode (DSR-450WS/450WSP only).....	108

---

## Chapter 6 Saving and Loading the User Setting Data

<b>Saving and Loading User Files .....</b>	<b>110</b>
Handling the “Memory Stick” .....	110
Saving USER menu data (user file) to the “Memory Stick” .....	111
Loading saved data from a “Memory Stick” .....	113
<b>Saving and Loading Scene Files .....</b>	<b>114</b>
Saving a scene file .....	114
Loading scene files .....	116
Resetting the settings of the camcorder to the standard settings .....	117
<b>Displaying a File-Related Menu Page When Inserting a “Memory Stick” .</b>	<b>118</b>

---

## Chapter 7 Appendix

<b>Important Notes on Operation .....</b>	<b>119</b>
Phenomena specific to CCD image sensors .....	120
<b>Maintenance .....</b>	<b>121</b>
Cleaning the video heads .....	121
Replacing the video heads .....	121
Replacing other parts .....	121
Using the auto-check function .....	121
<b>About i.LINK .....</b>	<b>123</b>
<b>About a “Memory Stick” .....</b>	<b>124</b>
<b>Operation Warnings .....</b>	<b>126</b>
<b>Troubleshooting .....</b>	<b>129</b>
<b>Specifications .....</b>	<b>131</b>
<b>Chart of Optional Components and Accessories .....</b>	<b>134</b>
<b>Glossary .....</b>	<b>136</b>
<b>Index .....</b>	<b>138</b>

## Product Configurations

The DSR-400/450WS Digital Camcorder series is made up of the DSR-400K/400PK, DSR-400L/400PL, and DSR-450WSL/450WSPL models depending on the product configuration, as shown in the figure below. The camcorders comprise both NTSC and PAL versions. The operation of the basic camcorder is the same in all cases.

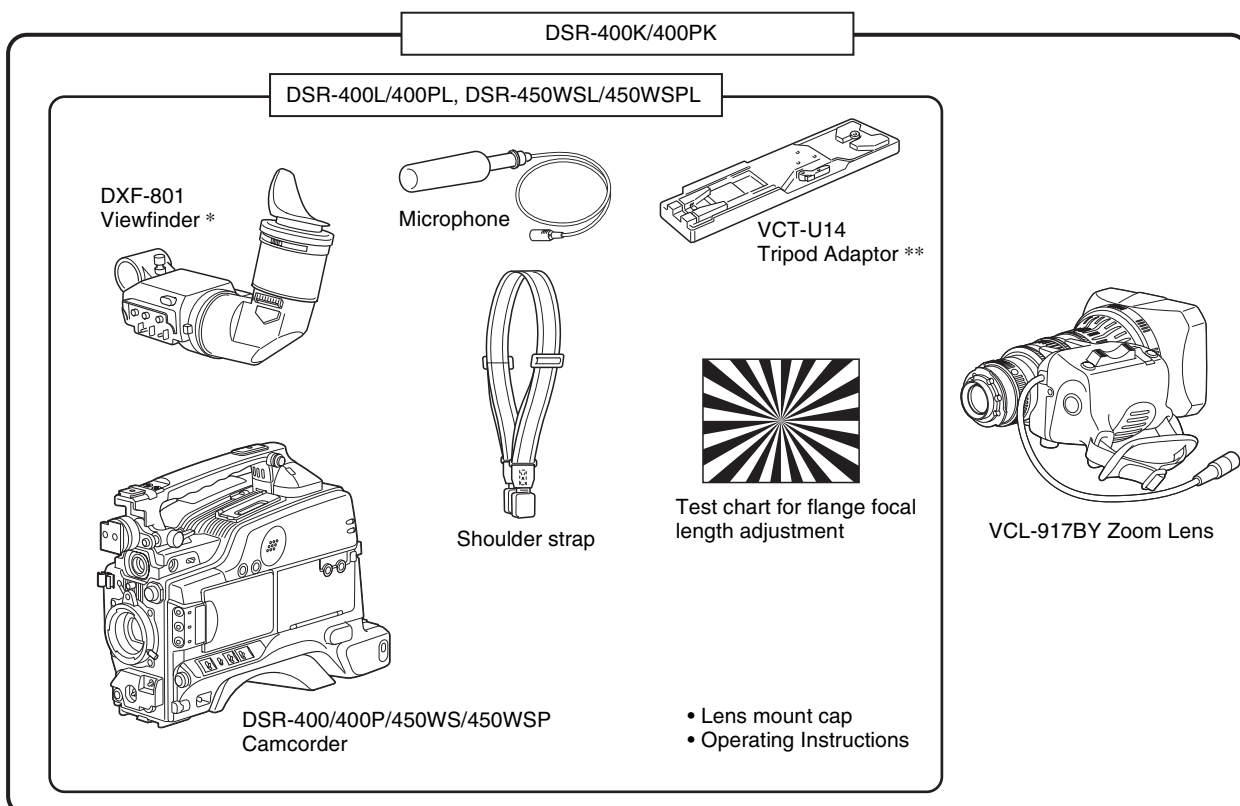

\* Service part number A-8279-329-A

\*\*Use the supplied tripod adaptor. For details, see "Fitting to a Tripod" on page 34.

# Features

The DSR-400/400P DVCAM\* digital camcorder is equipped with a 2/3-inch type Power HAD\* EX CCD with an aspect ratio of 4:3. The DSR-450WS/450WSP DVCAM digital camcorder is equipped with a 2/3-inch type Power HAD EX CCD with a wide-screen aspect ratio of 16:9. In addition to the same main features, functions, and operation method of previous models, these new camcorders provide superior camera functionality.

\* “DVCAM” and “Power HAD” are registered trademarks of Sony Corporation.

## Camera features

### 2/3-inch Power HAD EX CCDs

The three high-sensitivity, low-smear 2/3-inch Power HAD EX CCDs provide high image quality putting this camera at the top of its class for a standard NTSC/PAL definition camcorder.

- Smear: -140 dB
- Sensitivity: F11 (3200K, 2000lx)
- S/N ratio: 65 dB (DSR-400/450WS), 63 dB (DSR-400P/450WSP)

The DSR-450WS/450WSP allows you to switch between a 16:9 aspect-ratio wide image and a 4:3 aspect-ratio standard image.

### 2.5-inch color LCD monitor

A 2.5-inch color LCD monitor is mounted on the side of the camcorder. You can check the video image during both recording and playback. Also, the LCD monitor angle can be adjusted freely to make high-angle and low-angle recording easier. The time code and an audio level meter can also be displayed on the LCD monitor.

### Stylish design

The basic design of the camcorder has been improved. Stylish angles and an attractive finish for the VTR section are combined with a wide, easy-to-use connector section on the back of the camcorder.

### Adjustable shoulder pad

The camcorder is equipped with an adjustable shoulder pad that makes it possible to adjust the position of the camcorder to shoot from a stable position regardless of the body size and shooting style of the camera operator.

### Recording in progressive scan mode (DSR-450WS/450WSP only)

You can record in a progressive scan mode of 30 PsF (DSR-450WS) or 25 PsF (DSR-450WSP). (The video image is recorded as an interlaced scan signal (60i (DSR-450WS) or 50i (DSR-450WSP)).) Also for the DSR-450WS, a 24P mode makes it possible to record film-like

images. (The video image is recorded as an interlaced scan signal (60i) by 2-3 pull-down conversion.)

*For details on recording in progressive scan mode, see “Setting the CCD scan mode (DSR-450WS/450WSP only)” on page 108.*

### ASSIGN (Assignable) switches

Assignable switches provided on the side panel and on the top of the grip, respectively, can be assigned to functions such as ATW, VTR start/stop, etc., to suit your needs. When shooting, these functions can then be called up instantly.

### Scene file

You can save various settings for shooting a particular scene as a scene file in the internal memory of the camcorder. Loading the scene file, you can quickly recreate the same setup conditions suitable for shooting a particular scene.

### “Memory Stick” slot

The camcorder is equipped with a “Memory Stick” slot. When using the scene file function, you can save menu settings on a “Memory Stick” and quickly recall them when necessary. Also, when two or more camcorders are used for shooting, the settings of the first camcorder can be copied to the others via the “Memory Stick”, making color matching easier.

### Programmable gain

The value of gain that is assigned to the setting (H/M/L) of the GAIN switch can be selected from -3dB, 0dB, 3dB, 6dB, 9dB, 12dB, 18dB, 24dB, 30dB, and 36dB.

### Electric CC filter

The CC filter that was previously paired with the ND filter has been eliminated, so the ND filter is now the camcorder’s only optical filter and this makes operation of the camcorder easier. With the wide-band white balance amplifier of this camcorder, the white balance can be adjusted in a wide range of color temperatures without an optical CC filter.

### Auto-tracing white balance (ATW)

This function automatically traces the white balance, which constantly changes as lighting conditions change. Auto-tracing white balance is especially useful when there is no time to manually adjust the white balance, or when shooting moves between indoor and outdoor locations.

### A variety of shutter functions

#### • Electronic shutter

The high-performance electronic shutter allows you to record a video image at a high resolution even when shooting fast-moving objects.

#### • ECS

The ECS (Extended Clear Scan) mode allows you to adjust the shutter speed more precisely. You can set shutter speed



to a value close to the scan frequency of a computer display, so that the horizontal band and flicker that appear when recording a computer display can be reduced.

- **Slow shutter (DSR-450WS/450WSP only)**

A slow shutter function allows you to set the exposure time longer than 1 frame. By doing so, sensitivity is improved dramatically. Also, dreamlike images using the afterimages can be shot.

### Setting of multiple gamma curves (DSR-450WS/450WSP only)

Setting of multiple gamma curves is possible using a menu. You can shoot using image tones that suit your purpose, such as making film-like images.

### Dual zebra pattern display

Two types of zebra patterns can be set at independent display levels. They can be used in various ways; for example, one can be set to the brightness level of the main objects, and the other can be set to a higher brightness level.

### Video light connector

A video light connector (maximum 50 W) and control switch are provided. You can set the switch to turn the light on and off automatically as you start and stop the VTR.

### Remote control connectors (DSR-450WS/450WSP only)

Instead of making settings using menus, detailed settings of the camcorder can be made using an optional RM-B150 or B750 remote control unit connected to the camcorder.

### High-capacity BP-GL95 Battery Pack

The camcorder supports the information battery function. When using a BP-GL65/GL95 Battery Pack, more accurate and detailed information on remaining battery power is displayed in the viewfinder.

### High-functionality DXF-801 Viewfinder

The supplied DXF-801 Viewfinder has the following features.

- High resolution (600 TV lines of horizontal resolution)
- A DISPLAY switch that can turn the character display on and off
- A light for the lens control elements
- A large-diameter eye cup with a flip-up mechanism for viewing with the eye apart from it
- A peaking potentiometer for vertical and horizontal detail control
- A tough, die-cast aluminium body
- Automatic aspect ratio switching between 16:9 and 4:3 (DSR-450WS/450WSP only)

## VTR features

### Standard-size and mini-size DVCAM cassettes

Equipped with a tape drive with an original Sony mechanism, this camcorder can use both standard-size DVCAM cassettes (a standard cassette that can record a maximum of 180 minutes in DVCAM mode) and mini-size DVCAM cassettes (a small cassette that is convenient to carry and store). Both can be used without an adaptor.

### Compatible with DV recording (SP mode)

In addition to recording in DVCAM mode, this camcorder can record in the same DV mode that is widely available in consumer-use camcorders. (Only recording in SP mode is available. LP mode is not available for either recording or playback.) Recording in DV format allows a longer recording time, 270 minutes for a DVCAM 180-minute tape. This helps to reduce tape-changing time and the risk of missing important scenes when shooting a long event.

### PCM digital audio

For tapes recorded in DVCAM mode, recording/playback can be set to audio lock mode. You can choose between the two-channel recording mode (with a sampling frequency of 48 kHz) or the four-channel recording mode (with a sampling frequency of 32 kHz, records only CH-1 and CH-2 on this camcorder).

### i.LINK DV OUT connector\*

This camcorder has an i.LINK DV OUT connector. You can connect other DVCAM/DV recorders or i.LINK (DV) compatible non-linear editing equipment supporting a digital signal interface without degradation. Connecting external VTR equipment allows you to back up recordings to avoid missing any scenes by mistake. Also, you can set the REC TRIGGER switch to suit your needs and you can control the VTR sections of the camcorder and any external equipment independently.

\* "i.LINK" and i.LINK are trademarks.

### VBS video input signal (DSR-450WS/450WSP only)

By installing an optional CBK-SC01 Composite Input Board, the camcorder can input and record an external analog video signal. This is useful for pool coverage, etc.

### Interval Rec function

Using the Interval Rec function, you can create time-lapse videos. This is useful for various specialized projects, such as time-lapse recording of plant growth, etc.

# Location and Function of Parts

## Front view

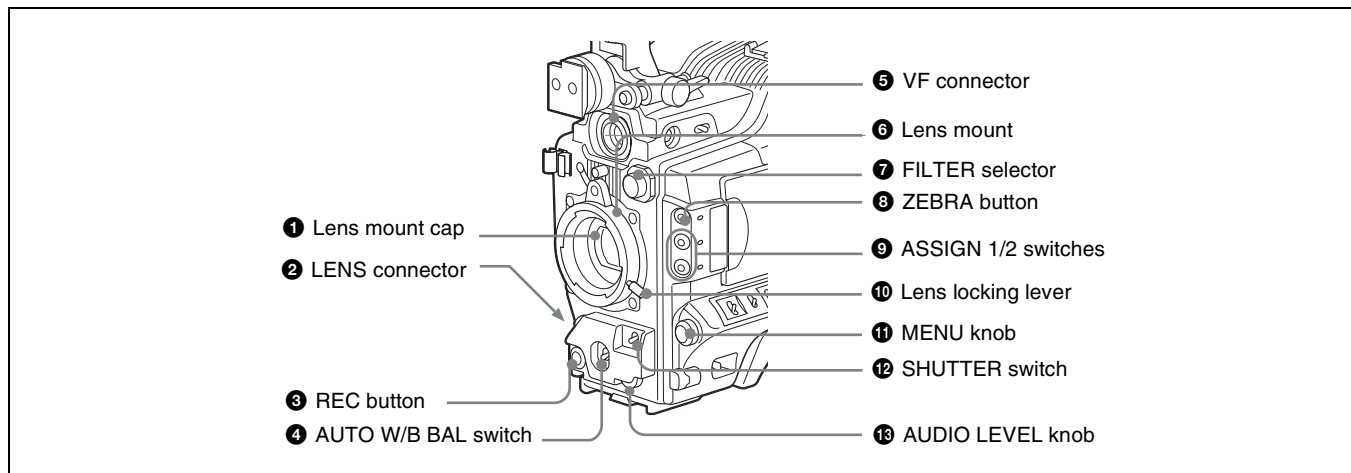

### 1 Lens mount cap

Remove by pushing up the lens locking lever (*page 11*). When no lens is mounted, keep this cap fitted for protection from dust.

### 2 LENS connector (12-pin)

Connect the lens cable. Contact your Sony representative for more information about the lens you can use.

### 3 REC (recording start) button

Press to start recording. Press it again to stop recording. The effect is exactly the same as that of the VTR button on the lens. When the REC SWITCH function is assigned to the ASSIGN switch on the FUNCTION 1 page of the OPERATION menu, you can use the switch as the REC button.

*You can select the recording format for the video signal from either DVCAM mode or DV-SP mode on the VTR MODE page of the MAINTENANCE menu.*

*In the recording pause state, the camcorder waits for a certain period of time in the standby-on mode and then automatically switches to standby-off mode. This length of the standby-on period with no operation can be set to either 1 minute, 3 minutes, or 5 minutes on the VTR MODE page of the MAINTENANCE menu.*

### 4 AUTO W/B BAL (automatic white/black balance adjustment) switch

Activates the white/black balance automatic adjustment functions.

**WHT:** Adjusts the white balance automatically. If the WHITE BAL switch (*page 12*) is set to A or B, the white balance setting is stored in the corresponding memory.

**BLK:** Adjusts the black set and black balance automatically.

### 5 VF (viewfinder) connector (20-pin)

Connect the supplied DXF-801 Viewfinder.

### 6 Lens mount (special bayonet mount)

Attach the lens.

### 7 FILTER selector

Selects the most appropriate filter to match the light source illuminating the subject. When this selector is used with the display mode set to 3 (*page 100*), the new setting appears on the viewfinder screen for about 3 seconds.

#### FILTER selector setting and examples of shooting conditions

FILTER selector setting	Examples of shooting conditions
1 (CLEAR)	Studio halogen lighting (incandescent)
2 (1/4 ND)	Cloudy or rainy outdoor shooting, or to reduce the depth of field*
3 (1/16 ND)	Sunlight
4 (1/64 ND)	To reduce the depth of field in sunlight

\* The range over which the subject is sharply in focus. Thus, “reducing the depth of field” means that the range is reduced as well, and “increasing the depth of field” means that it is increasing as well.

**8 ZEBRA button**

Press to display a zebra pattern (diagonal stripes) in the viewfinder screen.

The zebra pattern is factory set to indicate picture areas where the video level is approximately 70%. However, on the VF SETTING page of the OPERATION menu, you can change the setting so that areas where the video level is 100% and above also displayed at the same time.

*For details, see “Setting the viewfinder” on page 101.*

**9 ASSIGN 1/2 switches**

You can assign the desired functions on the FUNCTION 1 page of the OPERATION menu.

*For details, see “Assigning functions to ASSIGN switches” on page 107.*

**10 Lens locking lever**

After inserting the lens in the lens mount, rotate the lens mount ring with this lever to lock the lens in position.

**11 MENU knob**

Changes the page selection or a setting within the menu.

*For details about how to use the MENU knob, see “Basic menu operations” on page 94.*

**12 SHUTTER switch**

Set to ON to use the electronic shutter. Flick to SEL to switch the shutter speed or shutter mode setting within the range previously set with the menu. When this switch is operated, the new setting appears on the setting change/adjustment progress message display area for about 3 seconds.

*For details about the shutter speed and shutter mode settings, see “Setting the electronic shutter” on page 53.*

**13 AUDIO LEVEL knob**

Adjusts the channel 1 audio input level manually. You can invalidate the setting of this knob in the F AUDIO VOL item on the AUDIO page of the MAINTENANCE menu.

**Right side view**

**Front section**

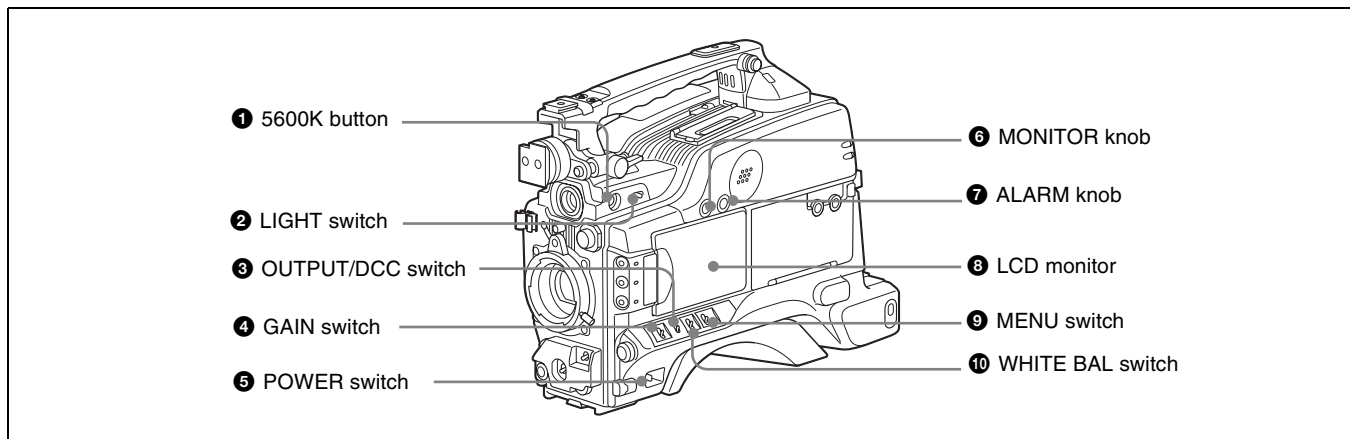

**1 5600K button**

Press to lit the button and switch the standard color temperature for shooting to 5600K. Use this button for outdoor shooting in daytime or shooting under lighting with higher temperature. While setting the wide-band white balance, the button does not function.

**2 LIGHT switch**

Determines how a video light connected to the LIGHT connector (page 17) is turned on and off.

**AUTO:** When the POWER switch of the video light is in the on position, the video light is turned on automatically while the camcorder is recording.

**MAN:** You can turn the video light on or off manually, using its own switch.

**Note**

- When this switch is set to AUTO, at the beginning of the recording, the picture is recorded even though the lighting may fluctuate until the video light comes on. If the beginning of the recording is important, you should

set this switch to MAN. However, when using the interval recording mode, the video light is automatically turned on immediately before recording starts.

- To ensure proper operation of the video light, Sony recommends the use of the battery pack BP-GL65, BP-GL95, or BP-L60S with the camcorder.

### 3 OUTPUT /DCC (output signal/dynamic contrast control) switch

Switches the video signal, which is output to the VTR part, viewfinder, and video monitor from the camera part, between the following two.

**BARS:** Outputs the color bar signal.

**CAM:** Outputs the video signal from the camera. When this is selected, you can switch DCC\* on and off.

\* **DCC (Dynamic Contrast Control):** Against a very bright background with the iris opening adjusted to the subject, objects in the background will be lost in the glare. The DCC function will suppress the high intensity and restore much of the lost detail and is particularly effective in the following cases.

- Shooting people in the shade on a sunny day
- Shooting a subject indoors, against a background through a window
- Any high contrast scene

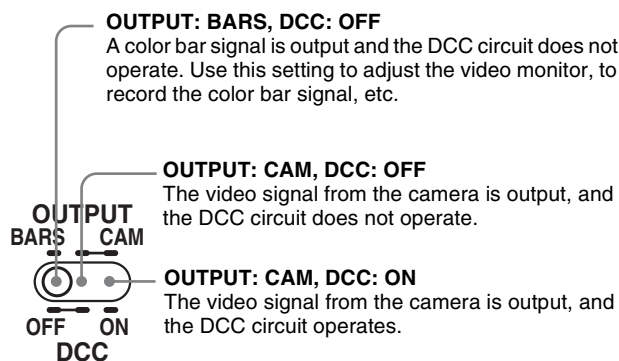

### 4 GAIN switch

Switches the gain of the video amplifier to match the lighting conditions during shooting. The gains corresponding to the L, M, and H settings can be selected in the menu. (The factory settings are L = 0 dB, M = 9 dB, and H = 18 dB.)

When this switch is adjusted, the new setting appears on the setting change/adjustment progress message display area of the viewfinder screen for about 3 seconds.

*For details, see "Setting gain values for the GAIN switch positions" on page 104.*

### 5 POWER switch

Turns the main power supply on and off.

### 6 MONITOR (monitor volume adjustment) knob

Controls the volume of the sound other than the warning tone that is output via the built-in speaker or earphones. Turning this knob to the minimum setting mutes the audio output.

### 7 ALARM (alarm tone volume adjustment) knob

Controls the volume of the warning tone that is output via the built-in speaker or earphones. Turning this knob to the minimum setting mutes the alarm tone.



### 8 LCD monitor

Displays VTR-related warnings, remaining battery capacity, remaining tape capacity, audio levels, time data, and so on.

*For details, see "Status display on the LCD monitor" on page 24.*

### 9 MENU switch

When flicking toward ON, the USER menu is displayed. When flicking toward STATUS, the status of the camcorder (of current settings) is displayed.

*For details, see "Displaying menus" on page 94.*

### 10 WHITE BAL (white balance memory) switch

Controls adjustment of the white balance.

**PRST:** Adjusts the color temperature to the preset value. Use this setting when you have no time to adjust the white balance.

**A or B:** When the AUTO W/B BAL switch (page 10) is pushed to WHT, the white balance is automatically adjusted according to the current position of the FILTER selector (page 10), and the adjusted value is stored in either memory A or memory B. There are two memories for each CC filter, allowing a total of eight adjustments to be stored. When this switch is set to A or B, the camcorder automatically adjusts itself to the stored value corresponding to the current settings of this switch and the FILTER selector. You can use the AUTO W/B BAL switch even when ATW\* is in use.

**B (ATW):** When this switch is set to B and WHITE SWITCH <B> is set to ATW on the FUNCTION 2 page of the OPERATION menu, ATW is activated. When this switch is adjusted, the new setting appears on the setting change/adjustment progress message display area of the viewfinder screen for about 3 seconds. You can assign the ATW function to the ASSIGN switch on the FUNCTION 1 page of the OPERATION menu.

*For details about how to assign the function to the ASSIGN switches, see "Assigning functions to ASSIGN switches" on page 107.*

\* **ATW (Auto Tracing White Balance):** The white balance of the picture being shot is adjusted automatically for varying lighting conditions.

## Left side of the LCD monitor

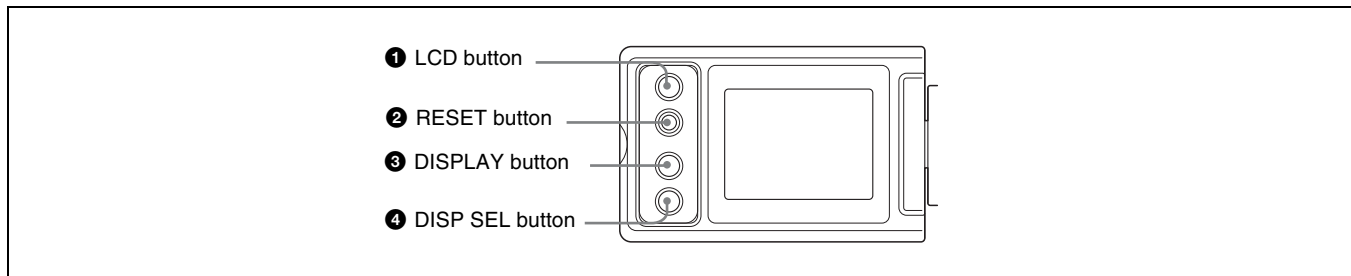

### 1 LCD button

Controls the LCD monitor. Each time pressing this button, the setting changes as follows.

**L:** The LCD monitor is adjusted for viewing indoors.

**H:** The LCD monitor is adjusted for viewing outdoors.

**OFF:** The LCD monitor is turned off.

### 2 RESET (counter reset) button

Resets the display of the time data when the LCD monitor display is set to STATUS with the DISP SEL button.

According to the settings of the PRESET/REGEN/CLOCK switch (page 15) and the F-RUN/SET/R-RUN switch (page 15), resets the display as follows.

Settings of the button and the switch	To reset
DISPLAY button: COUNTER	Counter to 0:00:00
DISPLAY button: TC PRESET/REGEN/CLOCK switch: PRESET F-RUN/SET/R-RUN switch: SET	Time code to 00:00:00:00
DISPLAY button: U-BIT PRESET/REGEN/CLOCK switch: PRESET F-RUN/SET/R-RUN switch: SET	User bit data* to 00 00 00 00

\* One of the time code bits recorded on a tape can be used to record the necessary information for the user.

For details, see "Setting the time data" on page 58.

### 3 DISPLAY (counter display toggle) button

Each time this button is pressed, the counter display section changes as follows. This setting is activated only when the LCD monitor display is set to STATUS with the DISP SEL button.

**COUNTER:** Displays the elapsed recording/playback time.

**TC:** Displays time code.

**U-BIT:** Displays user bit data.

### 4 DISP SEL (display selection) button

Each time pressing this button, the display in the LCD monitor changes as follows.

**CHAR:** Displays video with superimposed text. With the MENU switch set to STATUS, also display camcorder status indications similar to those displayed in the viewfinder.

**MONI:** Displays video without superimposed text.

**STATUS:** Displays counter, warnings, audio levels, etc.

## Rear section

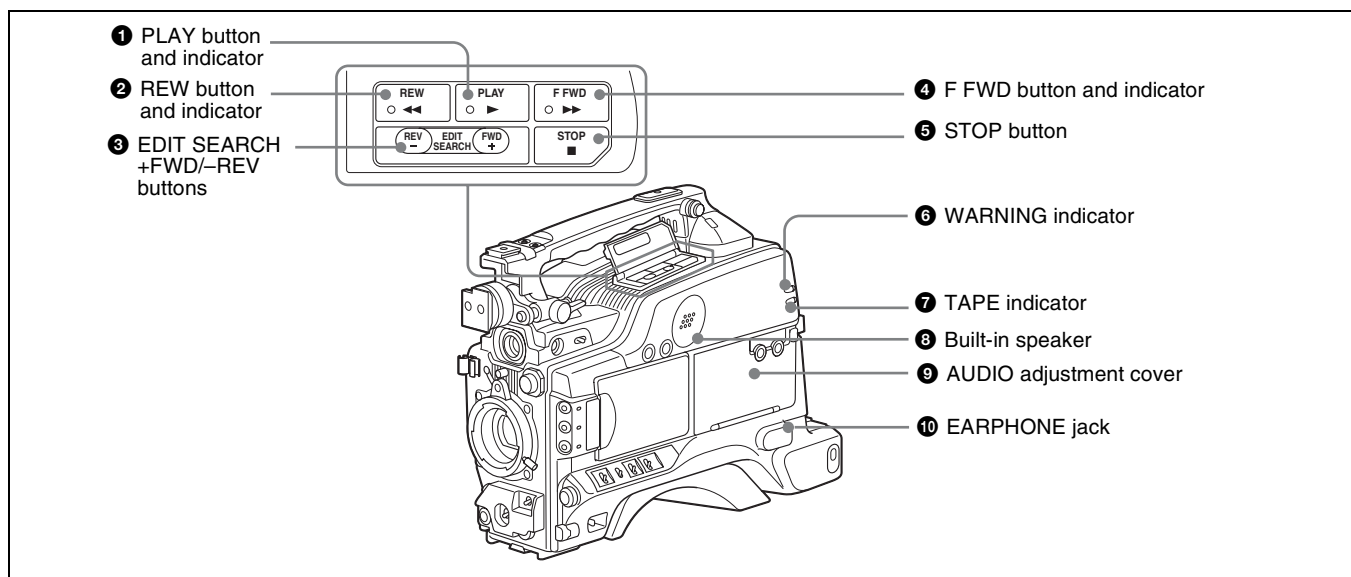

### 1 PLAY button and indicator

Press to view a playback image using the viewfinder or a LCD monitor. The indicator lights during playback.

Pressing this button again during playback pauses the playback, showing a still image. At this time, the indicator flashes. This camcorder is capable of color-image search at approximately nine-times (NTSC system) or eleven-times (PAL system) normal playback speed, making it easy to check recorded material. To use the color-image search, press and hold the REW or F FWD button during playback. While the button is pressed, the PLAY indicator and the REW or F FWD indicator light.

### 2 REW button and indicator

Rewinds the tape. The indicator lights while the tape is being rewound.

### 3 EDIT SEARCH +FWD/-REV buttons

Press these buttons in recording pause mode or in stop mode to find the next recording start point quickly. You can search in playback while pressing either of these buttons, or you can search by frame when pressing the button and releasing it immediately. If you do not operate the camcorder for about three seconds after releasing the buttons, the camcorder will enter the REC standby mode at the point where the buttons were released.

### 4 F FWD button and indicator

Fast forwards the tape. The indicator lights while the tape is being fast forwarded.

### 5 STOP button

Stops playing, rewinding, or fast forwarding the tape.

### 6 WARNING indicator

Lights up or blinks when an abnormality occurs in the VTR section.

For details about the meaning of the lights displayed, see “Operation Warnings” on page 126.

### 7 TAPE indicator

Lights up as below depending on the situation.

**Continuous:** When the cassette is in the camcorder.

**Blinking:** While the cassette is loading or ejecting.

**Lights-out:** When the cassette is not in the camcorder.

### 8 Built-in speaker

The speaker can be used to monitor E-E\* sound during recording, and playback sound during playback. The speaker also sounds alarms to reinforce visual warnings. If you connect earphones to the EARPHONE jack, the speaker is automatically muted.

\* **E-E:** Abbreviation of “Electric-to-Electric.” In E-E mode, video and audio signals input to the camcorder are output after passing through internal electric circuits only. This can be used to check input signals.

For information about alarms, see “Operation Warnings” on page 126.

### 9 AUDIO adjustment cover

Open to reveal the audio setting switches (page 15) and make audio adjustments.

### 10 EARPHONE jack (monaural)

Plugging earphones, and you can monitor the E-E sound during recording and playback sound during playback. When an alarm is indicated, you can hear the alarm sound through the earphones. Plugging earphones into the jack automatically cuts off the sound from built-in speaker.

## Operation panel under the AUDIO adjustment cover

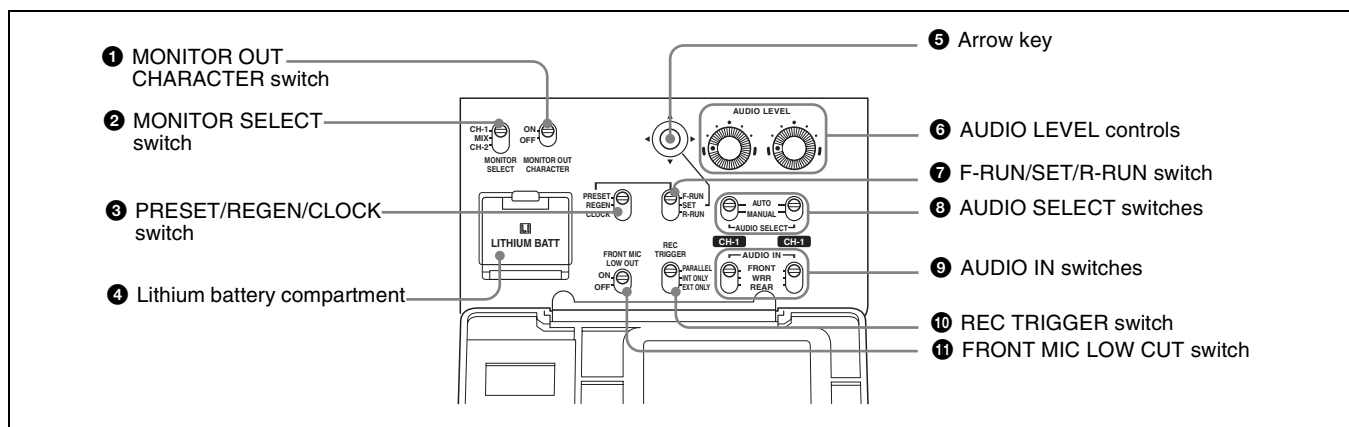

### 1 MONITOR OUT (monitor output) CHARACTER switch

Selects to superimpose text information on the monitor output.

### 2 MONITOR SELECT (audio monitor selection) switch

Selects audio output via the built-in speaker or earphones.

**CH-1:** Channel 1 audio

**MIX:** Mixed audio (channels 1 and 2)

**CH-2:** Channel 2 audio

### 3 PRESET/REGEN (regeneration)/CLOCK switch

Selects whether to set a new time code or to utilize the existing time code.

**PRESET:** Records a new time code.

**REGEN:** Records time code continuous with the existing time code recorded on the tape. Regardless of the setting of the F-RUN/SET/R-RUN switch, the camcorder operates in R-RUN mode.

**CLOCK:** Records time code synchronized to the internal clock. Regardless of the setting of the F-RUN/SET/R-RUN switch, the camcorder operates in F-RUN mode.

### 4 Lithium battery compartment

Attach the supplied CR2032 Lithium Battery.

*Details on how to attach the lithium battery, see "Attaching and Replacing the Lithium Battery" on page 28.*

### 5 Arrow key

Set the time code and the user bit. Push the key towards left or right so that the digit you want to change flashes. Pushing the key upward increases the value of the flashing digit, and pushing it downward decreases the value.

### 6 AUDIO LEVEL (CH-1/CH-2) (audio channel 1/2 recording level) controls

If the audio is input via the AUDIO IN CH-1/CH-2 connectors, adjusts the audio levels of channels 1 and 2 when the AUDIO SELECT (CH-1/CH-2) switches (see below) are set to MANUAL.

### 7 F-RUN/SET/R-RUN (free run/set/recording run) switch

Selects the operating mode for the internal time code generator. The operating mode is set as explained below, depending on the position of the switch.

**F-RUN:** Time code keeps advancing, regardless of the operating state of the VTR. Use this setting when synchronizing the time code with an external time code.

**SET:** Sets the time code or user bits.

**R-RUN:** The time code value advances only during recording. Use this setting to have a consecutive time code on the tape.

*For details, see "To set the time code" on page 58 and "To set the user bits" on page 59.*

### 8 AUDIO SELECT (CH-1/CH-2) (audio channel 1/2 adjustment method selection) switches

Select the audio level adjustment method for each of audio channels 1 and 2.

**AUTO:** Automatic adjustment

**MANUAL:** Manual adjustment

## 9 AUDIO IN (CH-1/CH-2) (audio channel 1/2 input selection) switches

Select the audio input signals to be recorded on audio channels 1 and 2. The audio input is sourced as explained below based on the position of the switches.

**FRONT:** The microphone connected to the MIC IN (+48 V) connector (*page 17*)

**WRR:** A WRR-855 UHF Synthesized Tuner Unit (not supplied)



**REAR:** Audio equipment connected to the AUDIO IN CH-1/CH-2 connectors (*page 19*)

The following settings can be made on the **AUDIO** page of the **MAINTENANCE** menu.

- **Audio recording format**  
Select either *Fs48K* or *32K*.
- **Audio reference level**  
Select either  $-12\text{ dB}$  or  $-20\text{ dB}$  (*DSR-400/450WS*),  $-12\text{ dB}$  or  $-18\text{ dB}$  (*DSR-400P/450WSP*).

- **Audio fade-in/fade-out**  
Select either **ON** or **OFF**.

## 10 REC TRIGGER (external VTR trigger) switch

Sets the function of the REC button on the camcorder or the VTR button on the lens when an external VTR is connected to the  (i.LINK) DV OUT connector (*page 19*). Set this switch to **INT ONLY** when you need to do cut editing or dubbing using the  (i.LINK) DV OUT connector.

**PARALLEL:** Operates both internal and external VTRs simultaneously.

**INT ONLY:** Operates the internal VTR only. External VTR operation is performed locally.

**EXT ONLY:** Operates the external VTR only.

## 11 FRONT MIC LOW CUT switch

Set to **ON** to insert a high-pass filter in the microphone circuit, reducing wind noise. Normally leave the switch in the **OFF** position.

## Left and upper view

### Front section

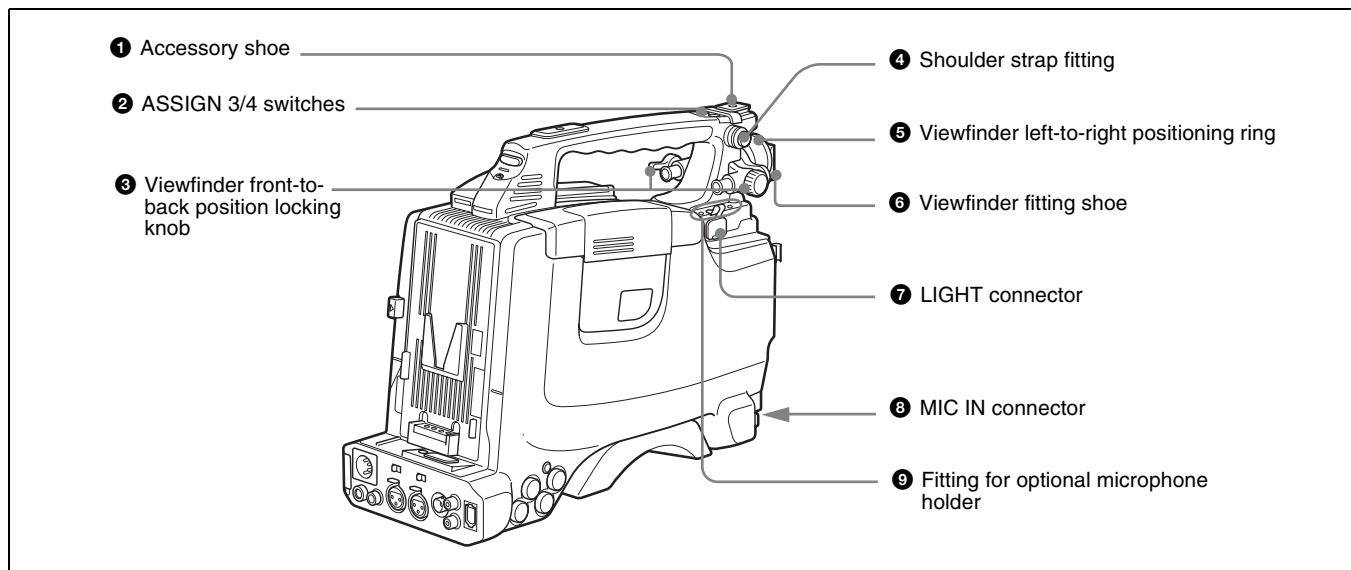

### 1 Accessory shoe

Attach an optional accessory such as a video light (*page 34*).

### 2 ASSIGN 3/4 switches

You can assign the desired functions on the **FUNCTION 1** page of the **OPERATION** menu.

For details, see “Assigning functions to **ASSIGN switches**” on *page 107*.

### 3 Viewfinder front-to-back position locking knob

Loosen this knob to adjust the front-to-back position of the viewfinder (*page 31*).

### 4 Shoulder strap fitting

Attach the supplied shoulder strap (*page 33*).

### 5 Viewfinder left-to-right positioning ring

Loosen this ring to adjust the left-to-right position of the viewfinder (*page 31*).



- 6 Viewfinder fitting shoe**  
Attach the DXF-801 Viewfinder.

- 7 LIGHT (video light) connector (2-pin, female)**  
A video light with a maximum power consumption of 50 W, such as the Anton Bauer Ultralight 2 or equivalent can be connected (page 34).

- 8 MIC IN (microphone input) (+48V) connector (XLR type, 3-pin, female)**  
Connect the supplied microphone to this connector. A microphone other than the one supplied may also be connected as long as it can operate with power source supplied by external equipment. The power (+48 V) is supplied via this connector.

- 9 Fitting for optional microphone holder**  
Fit an optional CAC-12 Microphone Holder (page 35).

**Rear section**

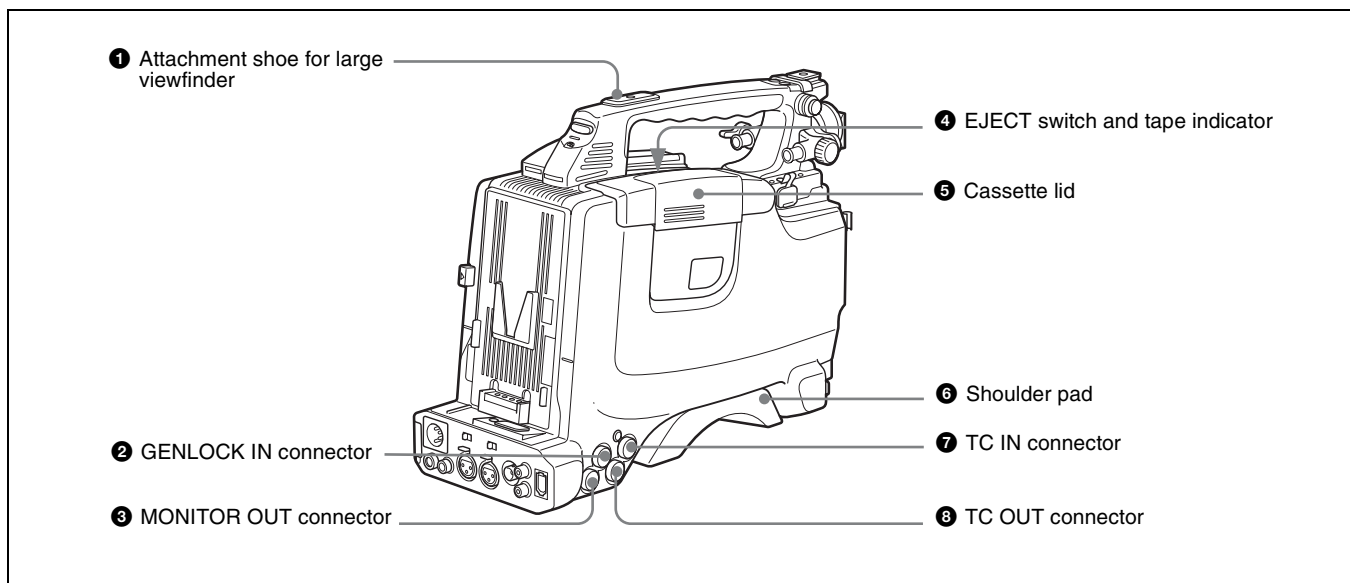

- 1 Attachment shoe for large viewfinder**  
Attach an optional electronic viewfinder (page 32).

- 2 GENLOCK IN connector (BNC type)**  
Use for the following two purposes.
  - **For DSR-400/400P/450WS/450WSP:** Inputs a reference signal when the camcorder is to be genlocked or when time code is to be synchronized with external equipment. Use the GENLOCK page of the MAINTENANCE menu to adjust the genlock H-phase (phase of horizontal sync signal) and the sub-carrier phase.
  - **For DSR-450WS/450WSP only:** Inputs an external video signal. Installing a CBK-SC01 Composite Input Board allows you to record external analog composite video signals input via this connector. Non-standard video signals, such as VHS, cannot be recorded.

For details, see “Recording Analog Composite Signals (with a CBK-SC01 Installed- DSR-450WS/450WSP only)” on page 65.

- 3 MONITOR OUT connector**  
Outputs a composite video signal for a video monitor. Depending on menu settings, menus, time code, and shot data can be superimposed on the image on the monitor.

Like the VIDEO OUT connector (page 19), this connector can also be used to synchronize the time code of an external VTR with the time code of the camcorder.

**Note**  
When connecting the camcorder to an external equipment using this connector, terminate the connecting cable. If the cable is not terminated, the picture will not be output from the camcorder to the external equipment.

- 4 EJECT switch and tape indicator (inside the cassette lid)**  
Press to eject a cassette when the power is supplied to the camcorder. The indicator lights up as below.
  - Continuous:** When the cassette is in the camcorder.
  - Blinking:** While the cassette is loading or ejecting.
  - Lights-out:** When the cassette is not in the camcorder.

- 5 Cassette lid**  
Slide the OPEN lever on the top of the camcorder to open the lid. Press the side of the lid to close it.

## 6 Shoulder pad

You can move the shoulder pad forwards or backwards by raising up the shoulder pad locking lever. Do this to ensure the best balance when shooting with the camcorder on your shoulder.

For details about how to adjust the pad, see “Adjusting the Shoulder Pad Position” on page 33.

## 7 TC IN (time code input) connector (BNC type)

To synchronize the time code of the camcorder to an external time code, connect the camcorder to the external

equipment with the reference time code using this connector.

## 8 TC OUT (time code output) connector (BNC type)

To synchronize the time code of an external VTR to that of the camcorder, connect the camcorder to the reference time code input connector of the external VTR using this connector.

For details about the time code, see “To set the time code” on page 58.

## Rear view

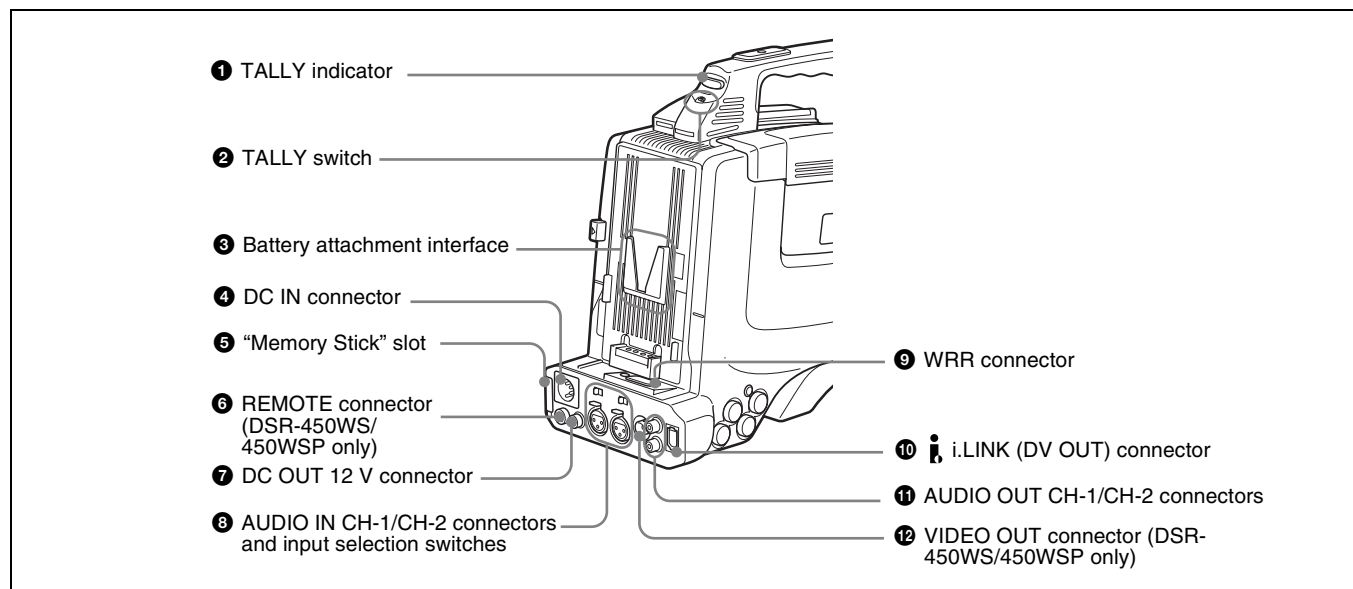

### 1 TALLY (back tally) indicator (red)

Lights up during recording. It will not light if the TALLY switch (see below) is set to OFF. This indicator also blinks to indicate warnings (page 14) in the same manner as the REC/TALLY indicator in the viewfinder.

For details, see “Operation Warnings” on page 126.

### 2 TALLY switch

Set to ON to activate the TALLY indicator (see above) function.

### 3 Battery attachment interface

Attach a BP-GL65/GL95/L60S battery pack. Furthermore, by attaching an AC-DN10 AC Adaptor, you can operate the camcorder using an AC power supply.

For details about how to attach the battery and AC adaptor, see “Preparing a Power Supply” on page 30. For information about attaching a synthesized tuner, see “Attaching a UHF Portable Tuner (for a UHF Wireless Microphone System)” on page 36.

### Note

For your safety, and to ensure proper operation of the camcorder, Sony recommends the use of the following battery packs: BP-GL65, BP-GL95, and BP-L60S.

### 4 DC IN connector (XLR type, 4-pin, male)

To operate the camcorder using an AC power supply, connect an AC-550 AC Adaptor with the DC output cable supplied with the adaptor.

### 5 “Memory Stick” slot

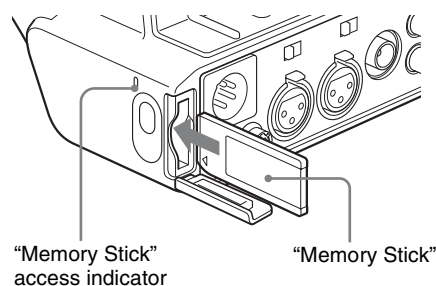

Insert a “Memory Stick”. The “Memory Stick” access indicator lights up when the “Memory Stick” is being accessed for reading or writing.

For details about how to insert a “Memory Stick”, see “To insert a “Memory Stick”” on page 110.

For details about the types of “Memory Stick”, see “About a “Memory Stick”” on page 124.

#### Note

Do not remove a “Memory Stick” while the “Memory Stick” access indicator is lit. Doing so may cause a loss of data.

#### 6 REMOTE connector (8-pin) (DSR-450WS/450WSP only)

Connect a RM-B150/B750 Remote Control Unit, which makes it possible to control the camcorder remotely.

#### Note

Before connecting or disconnecting the camcorder and a remote control unit, turn off the camcorder.

#### 7 DC OUT 12 V (DC power output) connector (4-pin, female)

Supplies power for a WRR-861/862 UHF Synthesizer Tuner (optional) (maximum 0.2 A).

Do not connect any equipment other than the UHF synthesizer tuner.

#### 8 AUDIO IN CH-1/CH-2 (audio input channel 1/2) connectors (XLR-3 pin, female) and input selection switches

Connect other audio equipment or external microphone. Set the input selection switches as shown below according to the microphone or equipment.

**MIC +48V ON (right position):** For connecting to a 48 V microphone

**MIC (center position):** For connecting any microphone other than 48 V microphone

**LINE (left position):** For connecting an external audio signal source such as a stereo amplifier

#### Note

If MIC +48V ON is selected for a microphone other than 48 V microphone, the microphone may be damaged.

#### 9 WRR connector (7-pin)

Connect a CA-WR855 Camera Adaptor with attached WRR-855 UHF Synthesizer Tuner.

For details, see “Attaching a UHF Portable Tuner (for a UHF Wireless Microphone System)” on page 36.

#### 10 i.LINK DV OUT connector (6-pin, IEEE1394 compliant)

Connect to a device supporting the DV format or a computer, using i.LINK cable (DV cable).

#### Notes

- If video and audio signals from an external device connected to the i.LINK DV OUT connector are not output, disconnect the i.LINK cable (DV cable) and then reconnect it, making sure that it is firmly seated.
- When you connect the camcorder and other equipment, such as a hard disk drive, with an i.LINK interface to a computer with i.LINK connectors, turn off the power of the computer, the other equipment, and the camcorder before connecting them using the i.LINK cable (DV cable). If a bus-powered type\* hard disk drive or similar equipment is connected while the computer is powered on, electric current flows into the camcorder because of the high voltage caused by the load shift of the computer power, and this may cause a malfunction.

\* Equipment that can be powered through i.LINK cable (DV cable)

#### 11 AUDIO OUT CH-1/CH-2 (audio output channel 1/2) connectors (pin jacks)

Output the sound being recorded or played back. Connect to a stereo amplifier or video monitor’s audio input connectors.

#### 12 VIDEO OUT connector (BNC type) (DSR-450WS/450WSP only)

Outputs a composite video signal for a video monitor. With a video monitor connected to this connector, you can monitor the picture being shot by the camera or the picture played back by the VTR. When synchronizing the time code of an external VTR with that of the camcorder, connect this connector to the GEN LOCK IN connector of the external VTR. By installing the CBK-SD01 SDI Output Board (optional), you can output an SDI signal (supporting embedded audio and the EDH function) from this connector. To switch the composite video signal output to SDI signal output, use the menu.

For details on how to select the output signal, see “Selecting the output signals (DSR-450WS/450WSP only)” on page 105.

#### Note

When connecting the camcorder to an external equipment using this connector, terminate the connecting cable. If the cable is not terminated, the picture will not be output from the camcorder to the external equipment.

# Lens

## VCL-917BY Zoom Lens (DSR-400K/400PK only)

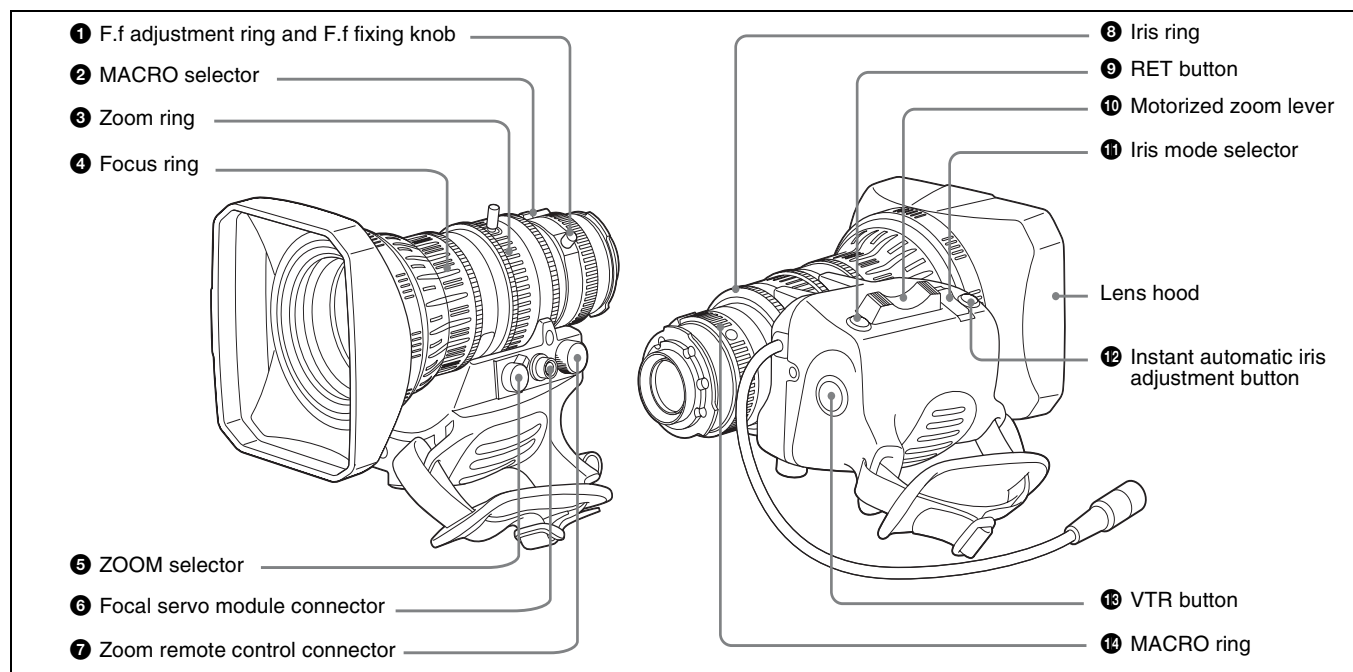

### 1 F.f (flange focal length) adjustment ring and F.f fixing knob

**F.f adjustment ring:** To adjust the flange focal length, loosen the F.f fixing knob, then turn the ring (*page 29*).

**F.f fixing knob:** Fixes the F.f adjustment ring.

### 2 MACRO (close-up) selector

Turn the MACRO ring while pressing and holding this button for close-up work.

### 3 Zoom ring

Turn this ring for direct manual zoom control. Set the ZOOM selector (see below) to the M position beforehand.

### 4 Focus ring

Turn this ring to focus the lens on the subject.

### 5 ZOOM selector

Selects the mode of zoom operation.

**S:** Power zoom

**M:** Manual zoom

### 6 Focal servo module connector

Attach a servo module to drive focal adjustment.

### 7 Zoom remote control connector (8-pin)

Connect an optional lens remote control unit for remote control of zooming.

For details of the lens remote control unit, please contact Fuji Photo Optical Co., Ltd. (FUJINON)

### 8 Iris ring

Turn this ring for manual iris control. Set the Iris mode selector (see below) to the M position beforehand.

### 9 RET (return) button

Use to check the recorded image. When the internal VTR is in recording pause mode, press this button to review the last few seconds of the recording in the viewfinder (recording review).

For details, see "Playing and Checking Recorded Contents" on page 66.

### 10 Motorized zoom lever

Press further to increase the zoom speed. Press only slightly to decrease the zoom speed.

### 11 Iris mode selector

This selects the mode of iris operation.

**A:** Automatic iris

**M:** Manual iris

### 12 Instant automatic iris adjustment button

While using manual iris control, press to switch temporarily to automatic iris control setting. Automatic control is maintained as long as you hold the button down.

**13 VTR button**

This button starts and stops recording on the VTR. Press it once to start recording, and once more to stop.

*In the recording pause state, the camcorder waits for a certain period of time in the standby-on mode and then automatically switches to standby-off mode. This length of the standby-on period with no operation can be set to either 1 minute, 3 minutes, or 5 minutes on the VTR MODE page of the MAINTENANCE menu.*

**14 MACRO (close-up) ring**

For close-up, turn this ring while holding the MACRO selector down.

**DXF-801 Viewfinder**

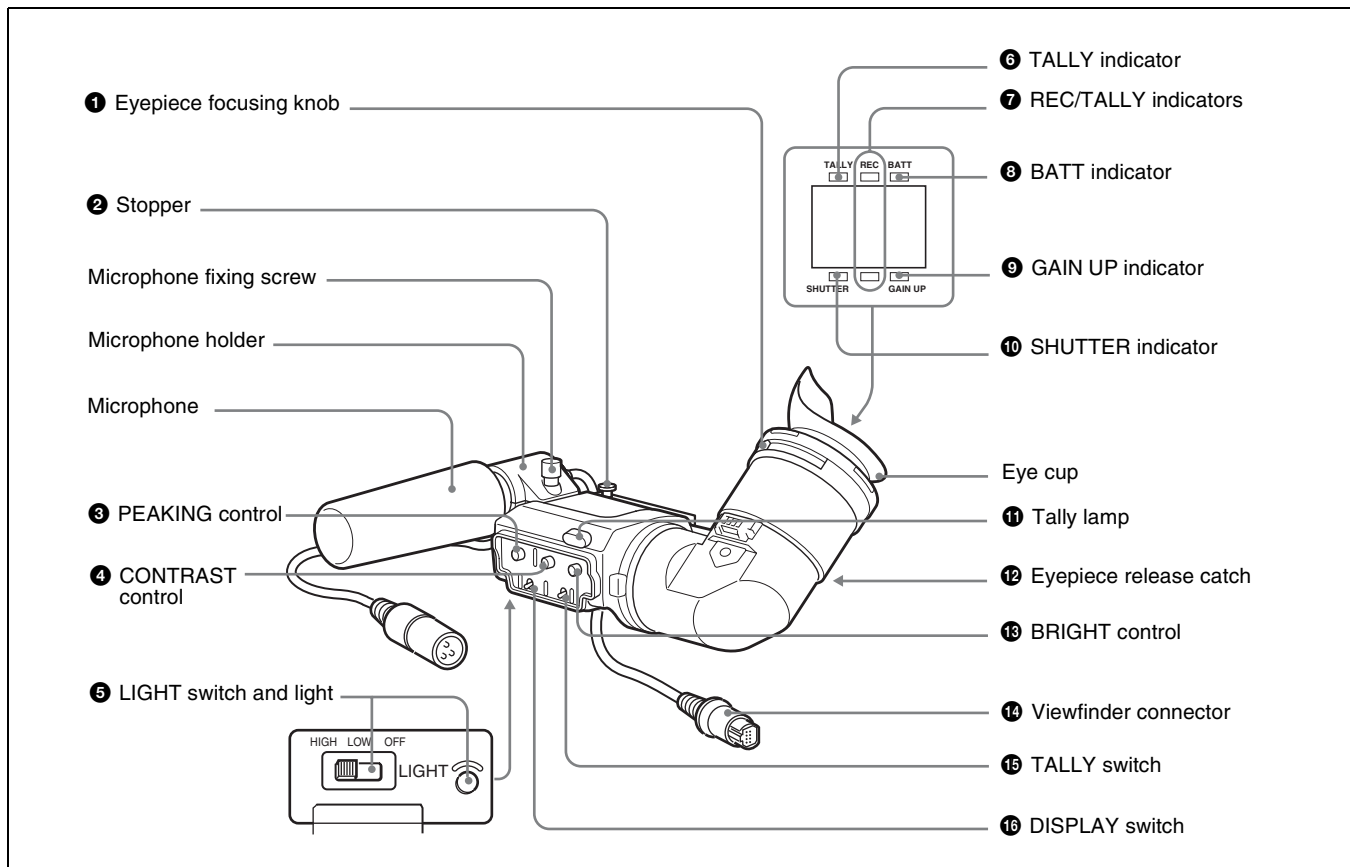

**Note**

You can switch the scan size of the DXF-801 in accordance with the aspect ratio selected on the camera or camcorder. It operates in 4:3 mode when connected to the DSR-400/400P. It operates in either 4:3 or 16:9 mode when connected to the DSR-450WS/450WSP.

**1 Eyepiece focusing knob**

Adjusts the viewfinder focus to match your eyesight (page 31).

**2 Stopper**

Lift up when detaching the viewfinder (page 31).

**3 PEAKING control**

Adjusts the outline intensity of the viewfinder image (page 31).

**4 CONTRAST control**

Adjusts the contrast of the viewfinder image (page 31).

**5 LIGHT switch and light**

The light lights the lens and the switch controls the light as follows.

**HIGH:** Brighter

**LOW:** Darker

**OFF:** Turns the light off.

**6 TALLY (tally) indicator (green)**

Flashes when the camcorder is in Interval Rec mode. Flashing quickens while you are shooting in Interval Rec mode.

For details on Interval Rec mode, see “Time-Lapse Video (Interval Rec)” on page 64.

**7 REC/TALLY (recording/tally) indicators (red)**

Functions as follows.

- Flashes from the time when you press the REC button on the camcorder or the VTR button on the lens until recording starts, then stay on continuously during recording.
- Indicates a fault (page 126).

The lower indicator can also function by setting in the menu (page 88).

**8 BATT (battery) indicator (red)**

Lights up when the battery capacity is low.

**9 GAIN UP indicator (orange)**

Lights up when the gain is 3 dB or more.

**10 SHUTTER indicator (red)**

Lights up when the SHUTTER switch (page 11) is ON.

**11 Tally lamp**

When the TALLY switch (see below) is in the ON position, this operates in the same way as the REC/TALLY indicators.

**12 Eyepiece release catch**

To view the viewfinder screen directly, press to hinge up the eyepiece.

**13 BRIGHT (brightness) control**

Adjusts the brightness of the viewfinder image (page 31).

**14 Viewfinder connector (20-pin)**

Connect to the VF connector (page 10).

**Note**

Push the connector all the way into the VF connector. If not so, the viewfinder image may be distorted or the tally lamps may not function properly.

**15 TALLY switch**

Set to the ON position to use the tally lamp.

**16 DISPLAY switch**

Set to OFF when you want to remove the character data from the viewfinder and the monitor connected to the MONITOR OUT connector (page 15).

**Status display on the viewfinder screen**

The viewfinder screen displays not only the video picture but also characters and messages indicating the camcorder settings and operating status, a center marker, a safety zone marker, etc.

When the MENU switch is set to OFF and the DISPLAY switch is set to ON, the items for which an ON setting was made in the VF DISP 1 page of the OPERATION menu or with related switches are displayed at the top and bottom of the screen.

The messages that give details of the settings and adjustment progress and results can also be made to appear for about 3 seconds while settings are being changed, during adjustment, and after adjustment.

For details about the display item selection, see “Selecting the display items” on page 99. For details about setting change and adjustment progress messages, see “Display modes and setting change confirmation/adjustment progress messages” on page 100. For details about marker display, see “Setting the marker display” on page 101.

**Layout of the status display on the viewfinder screen**

All items that can be displayed on the viewfinder screen are shown below.

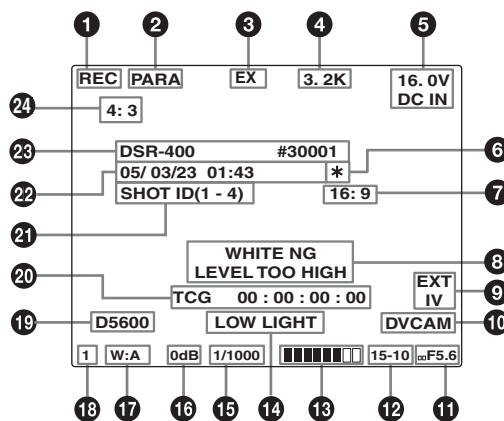



6, 7, 21, 22, and 23 appear only when color bars are displayed.

**1 VTR operation indicators**

VTR operation is displayed as follows:

**REC1:** The internal VTR is operating.

**REC2:** The external VTR connected to the  (i.LINK) DV OUT connector is operating.

**REC<sup>1,2</sup>:** Both the internal VTR and the external VTR connected to the  (i.LINK) DV OUT connector are operating.

**② Trigger mode**

**PARA:** Operates both internal and external VTRs.

**INT:** Operates the internal VTR only.

**EXT:** Operates the external VTR only.

**③ Extender**

“EX” is displayed when a lens extender is used.

**④ Color temperature**

Indicates the currently selected color temperature.

**⑤ DC IN / battery voltage / remaining capacity**

Indicates the battery voltage or the remaining capacity of an attached internal battery pack, an AC adaptor, or an external battery (a battery connected to the DC IN connector).

When the power is supplied from an external battery, “DC IN” appears here.

When the DISP BATT REMAIN item is set to INT on the VF DISP 2 page of the OPERATION menu, the battery voltage is not indicated.

However, when the Anton Bauer intelligent battery system or the BP-GL65/GL95 battery pack is used, the remaining battery capacity is automatically detected and indicated in steps of 10%.

- Until the remaining battery capacity is reduced to 40%, the indications MAX, 90%, 80%...40% are displayed for three seconds in the viewfinder each time the remaining battery capacity reduces by 10%.
- When the remaining battery capacity is less than 40%, the indication is displayed all the time.
- When the remaining battery capacity is less than 10%\*, the indication flashes. When the remaining battery capacity is reduced further, the “LOW” flashes.

\* This value can be set to either 10% or 20% on the FUNCTION 2 page of the OPERATION menu.

**⑥ \* (Asterisk indicator)**

Flashes when the color bars are displayed and is recorded together with the color bars.

**⑦ 16:9 mode recording indicator (DSR-450WS/450WSP only)**

Indicates recording in the 16:9 mode. This indicator is recorded together with the color bars.

**⑧ Setting change and adjustment progress message display area**

For details, see “Display modes and setting change confirmation/adjustment progress messages” on page 100.

**⑨ EXT/IV indicator (DSR-450WS/450WSP only)**

Displayed when a CBK-SC01 Composite Input Board is installed for input of external composite signals.

**⑩ Recording format**

Indicates the current recording format.

**⑪ Iris setting/auto iris override**

Indicates the F value (iris setting) of the lens.

Also, the auto iris override is displayed using two squares which appear in the upper and lower parts respectively.

For details, see “Adjusting the iris” on page 56.

**⑫ Remaining tape capacity**

Indicates the remaining tape recording time (in minutes) of the VTR.

**Examples of remaining tape recording time indication**

Indication	Remaining tape recording time
F - 30	Full to 30 minutes
30 - 25	30 to 25 minutes
25 - 20	25 to 20 minutes
20 - 15	20 to 15 minutes
15 - 10	15 to 10 minutes
10 - 5	10 to 5 minutes
5 - 0	5 to 0 minutes
No display	0 minute

**⑬ Audio level**

Indicates the level of audio channel 1 and channel 2. The peak indication of the VTR level meter is related as follows to the audio level when a 1kHz sine wave is input.

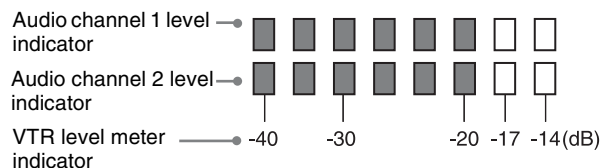
**⑭ Operation/error message display area**

For details, see “Operation/error messages” on page 128.

**⑮ Shutter speed**

Indicates the shutter speed or the shutter mode. However, if the SHUTTER switch (page 11) is set to OFF, nothing is displayed.

**1/100, 1/125, 1/250, 1/500, 1/1000, 1/2000:** Shutter speed (in seconds) in standard mode (scan mode: I)

**1/40, 1/60, 1/120, 1/125, 1/250, 1/500, 1/1000, 1/2000:** Shutter speed (in seconds) in standard mode (scan mode: PsF)

**ECS:** In ECS (Extended Clear Scan) mode

**EVS:** In EVS (Super Enhanced Vertical Definition System) mode

**1F to 8F, 16F (DSR-450WS/450WSP only):** Number of frames in the slow speed shutter mode

**⑯ Gain**

Indicates the gain of the video amplifier, as set by the GAIN switch.

**17 White balance memory**

Indicates the currently selected white balance automatic adjustment memory.

**A:** Displayed when the WHITE BAL switch is set to A.

**B:** Displayed when the WHITE BAL switch is set to B.

**P:** Displayed when the WHITE BAL switch is set to PRST or when the preset button on an RM-B150 has been pushed.

**T:** Displayed when ATW is being used.

**18 Filter**

Indicates the currently selected filter types.

**19 5600 indicator**

Appears when the electric color temperature filter function is on.

**20 Time code**

Indicates the elapsed recording/playback time, the time code, user bits or other information selected by the DISPLAY switch (*page 22*).

**21 ID number**

Indicates the ID number selected from ID 1 to ID 4 when the color bars are displayed. The ID number is recorded together with the color bars.

**22 Date and time**

Indicates the date and time of recording when the color bars are displayed, which are recorded together with the color bars.

**23 Model name and serial number**

Indicates the model name and serial number of the camcorder when the color bars are displayed, which are recorded together with the color bars.

**24 16:9/4:3 mode**

“16:9” or “4:3” is displayed depending on the currently selected aspect ratio.

**Note**

The 16:9 mode can be selected for the DSR-450WS/450WSP.

**Status display on the LCD monitor**

The following display appears when the LCD monitor display is set to STATUS with the DISP SEL button.

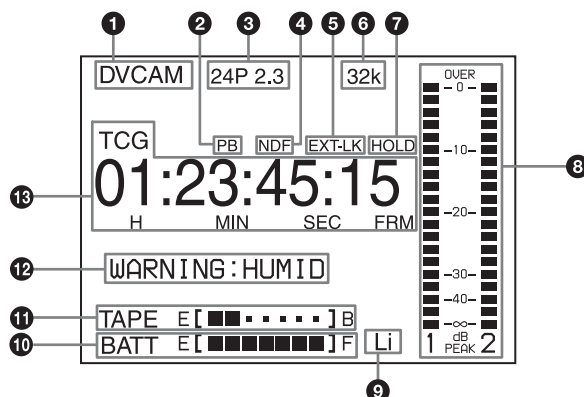
**1 Video format**

Indicates the video format of the image that is currently playing or being recorded.

**DVCAM:** The video format is set to DVCAM mode.

**DV-SP:** The video format is set to DV-SP mode.

**2 Playback indicator**

Appears during playback.

**3 Camera scan mode indicator**

Indicates the camera scan mode of the image that is currently playing back or being recorded.

**• For DSR-400/450WS only**

**60i:** 60 fields per second, interlace scan mode

**30P:** 30 frames per second, progressive scan mode

**24P 2.3:** 24 frames per second, progressive scan mode (converted to 60i at 2-3 pulldown)

**24P 2.3.3.2:** 24 frame per second, progressive scan mode (converted to 60i at 2-3-3-2 pulldown)

**• For DSR-400P/450WSP only**

**50i:** 50 fields per second, interlace scan mode

**25P:** 25 frames per second, progressive scan mode

**Note**

There may be no indication displayed when this unit cannot identify the camera scan mode, for example, when playing back a tape recorded with other equipment.

**4 Non drop-frame mode indicator (DSR-400/450WS only)**

Appears when non-drop frame mode is selected.

**5 External synchronization indicator**

Appears when the internal time code generator is locked to an external signal input to the TC IN connector.



### 6 Audio format

Indicates the audio format of image that is currently playing or being recorded.

**32k:** 12 bit Fs32K (4ch mode)

**44.1k:** 16 bit Fs44.1K (2ch mode)

**48k:** 16 bit Fs48K (2ch mode)

#### Note

Recording in 16 bit Fs32K and 16 bit Fs44.1K are not possible on the camcorder.

### 7 Hold indicator

Appears when the internal time code generator is stopped.

### 8 Audio level indicators

Indicates the audio recording or playback levels of channel 1 and channel 2.

### 9 Lithium backup battery warning

Appears when the voltage of the internal lithium backup battery (CR2032) is low. If this indication appears, replace the lithium backup battery immediately (*page 30*).

### 10 Battery capacity indicator

Indication	Battery voltage		
	BP-L60S/L90A/L60A/L90/L60	BP-90A/NP-1B	Other batteries
BATT E [ ■■■■■■■■ ] F	15.5V or more	12.0V or more	17.0V or more
BATT E [ ■■■■■■■ ] F	15.1 to 15.5V	11.7 to 12.0V	16.0 to 17.0V
BATT E [ ■■■■■■ ] F	14.6 to 15.1V	11.5 to 11.7V	15.0 to 16.0V
BATT E [ ■■■■■ ] F	13.8 to 14.6V	11.3 to 11.5V	14.0 to 15.0V
BATT E [ ■■■■ ] F	12.9 to 13.8V	11.1 to 11.3V	13.0 to 14.0V
BATT E [ ■■■ ] F	12.0 to 12.9V	10.9 to 11.1V	12.0 to 13.0V
BATT E [ ■■ ] F	10.8 to 12.0V	10.5 to 10.9V	11.0V to 12.0V
BATT E [ ■ ] F	10.8V or less	10.5V or less	11.0V or less

Indication	Battery voltage
	<b>BP-IL75/GL65/GL95/ M100/M50, Anton Bauer Battery System</b>
BATT E [ ■■■■■■■■ ] F	80 to 100%
BATT E [ ■■■■■■■ ]	70%
BATT E [ ■■■■■■ ]	60%
BATT E [ ■■■■■ ]	50%
BATT E [ ■■■■ ]	40%
BATT E [ ■■■ ]	30%
BATT E [ ■■ ]	20%
BATT E [ ■ ]	10%
BATT E [ ]	0%

### 11 Tape remaining indicator

Indication	Tape time remaining
TAPE E [ ■■■■■■■■ ] B	30 minutes
TAPE E [ ■■■■■■■ ] B	25 to 30 minutes
TAPE E [ ■■■■■■ ] B	20 to 25 minutes
TAPE E [ ■■■■■ ] B	15 to 20 minutes
TAPE E [ ■■■■ ] B	10 to 15 minutes
TAPE E [ ■■■ ] B	5 to 10 minutes
TAPE E [ ■■ ] B	2 to 5 minutes
TAPE E [ ■ ] B (flashing)	0 to 2 minutes
TAPE E [ ] B (flashing)	0

**12 Warning indicators**

Displays warnings when trouble with recording or moisture condensation occurs.

For details, see “Operation Warnings” on page 126.

**13 Time counter indicator**

Each press of the DISPLAY button switches displays of time code, user bit, and counter. You can display the date or time using the arrow key under the AUDIO adjustment cover.

**TCG:** Value of time code generator

**TCR:** Value of time code reader

**UBG:** Value of user bit generator

**UBR:** Value of user bit reader

**CNT:** Counter indicator

**CLK:** Current time data

**DAT:** Current date

*TCG and UBG can be displayed when the tape is stopped and during recording, and TCR and UBR are displayed during playback.*

*CLK can be displayed when the center of the arrow key is pressed while TC is being displayed by pressing the DISPLAY button.*

*DAT can be displayed when the center of the arrow key is pressed while U-BIT is being displayed by pressing the DISPLAY button.*

---

## Using the CD-ROM Manual

The supplied CD-ROM includes versions of the Operation Manual for the DSR-400/450WS in English, French, German, Italian, and Spanish in PDF format.

---

### Preparations

The following program must be installed on your computer in order to read the operation manuals contained on the CD-ROM.

- Adobe Reader Version 6.0 or higher

#### Memo

If Adobe Reader is not installed, you can download it from the following URL:

<http://www.adobe.com/>

Adobe and Adobe Reader are trademarks of Adobe Systems Incorporated in the United States and/or other countries.

---

### Reading the CD-ROM Manual

To read the operation manual contained on the CD-ROM, do the following.

- 1 Insert the CD-ROM in your CD-ROM drive.

A cover page appears automatically in your browser. If it does not appear automatically in the browser, double-click on the index.htm file on the CD-ROM.

- 2 Select and click on the operation manual that you want to read.

This opens the PDF file of the operation manual.

#### Memo

The files may not be displayed properly, depending on the version of Acrobat Reader. In such a case, install the latest version you can download from the URL mentioned in “Preparations” above.

#### Notes

- If you have lost or damaged the CD-ROM, you can purchase a new one to replace it. Contact your Sony service representative.
- You can purchase a printed version of the operation manual (English version). Contact your Sony service representative.

When ordering, be sure to specify the part number of the manual you want.

Part No.	Models covered
3-868-499-1X	DSR-400/DSR-450WS



## Attaching and Replacing the Lithium Battery

This camcorder uses a lithium battery to retain stored data. When using the camcorder for the first time, be sure to attach the supplied lithium battery (CR2032). The camcorder will not operate correctly without this lithium battery. After attaching the lithium battery, set the date and time of the internal clock (see “Setting the date/time of the internal clock” on page 106).

### Notes

- Carefully read the instructions for attaching and replacing the lithium battery. Lithium batteries can explode if misused.
- Use only CR2032 Lithium Batteries. Other types of lithium batteries may come loose when this camcorder is moved. If you have difficulty finding CR2032 Lithium Batteries, contact your Sony dealer.

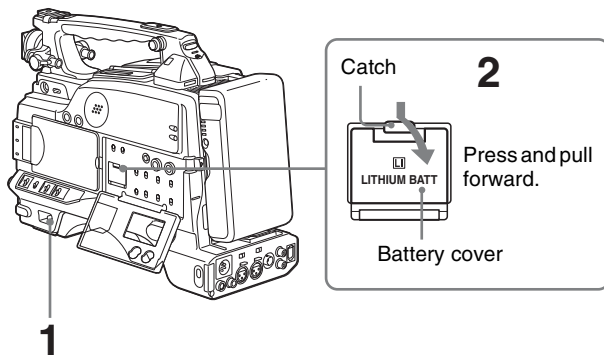

- 1 Set the POWER switch to on.
- 2 Press down the catch at the top of the battery cover and open the cover.

- 3 Take out the lithium battery.

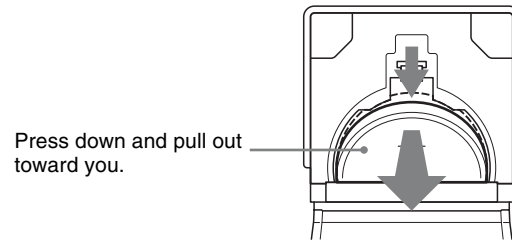

- 4 Reverse step 3 to insert a replacement lithium battery. Make sure that the + symbol on the battery is facing you.
- 5 Close the battery cover.

### Service life of the lithium battery

When the lithium battery's voltage falls, the lithium battery power replacement warning appears on the LCD monitor (page 24). If this warning appears, replace the lithium battery (■ CR2032) within three or four days. The lithium battery has an average service life of about one year.

# Preparing the Lens

## Mounting the lens

Mount the lens using the following procedure.

For information about using the lens, refer to the operating instructions for the lens.

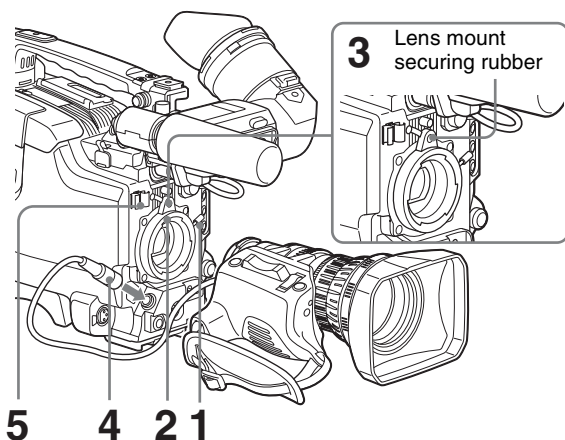

- 1** Push the lens locking lever up and remove the lens mount cap from the lens mount.
- 2** Align the center slot in the lens mount with the center pin on the lens, and insert the lens into the mount.
- 3** Holding the lens in place, push the lens locking lever down to mount the lens.

### Note

If the lens is not firmly locked, it may come off while the camcorder is being used. This could cause a serious accident. Make sure the lens is firmly locked. It is recommended that the lens mount securing rubber be put on the lens-locking lever as illustrated above.

- 4** Connect the lens cable to the LENS connector.

### Note

Connecting the lens cable to the LENS connector when the camcorder is powered may cause a malfunction of the camcorder or the lens. Turn off the camcorder before connecting the LENS connector.

- 5** Secure the lens cable with the cable clamps.

## Adjusting the flange focal length

It is necessary to adjust the flange focal length (the distance from the lens flange to the plane of the image along the optical axis) in the following cases.

- When a lens is fitted for the first time
- After changing lenses
- When during zoom operations the focus does not match properly from telephoto to wide angle

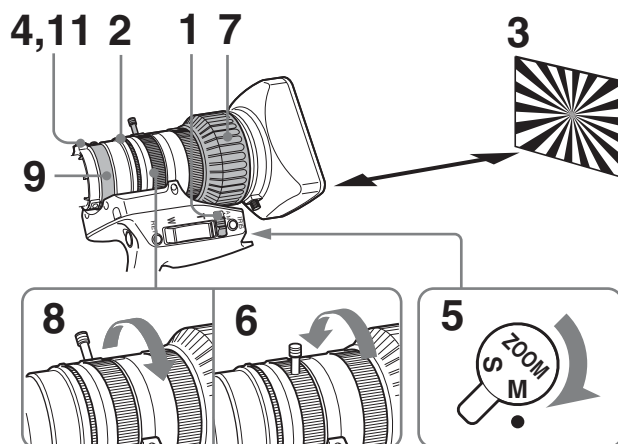

- 1** Set the iris selector to the M (Manual) position.
- 2** Turn the iris ring to open it.  
Adjust the light or the ND filter so that an appropriate brightness is obtained with the iris open.
- 3** Place the supplied flange focal length adjustment test chart at a range of about 3 meters (10 feet), and adjust the light so that an appropriate video level is obtained with the iris open.
- 4** Loosen the F.f fixing knob.
- 5** Set the ZOOM selector to the M position.
- 6** Turn the zoom ring to the telephoto position.
- 7** Turn the focus ring so that the test chart is in focus.
- 8** Turn the zoom ring to the wide angle position.
- 9** Turn the F.f fixing ring so that the test chart is in focus.  
Do not move the focusing ring.
- 10** Repeat steps **6** to **9** until the image stays in focus from telephoto to wide angle.
- 11** After adjustment, tighten the screw of the F.f fixing knob.

# Preparing a Power Supply

The following power supplies are recommended for the camcorder.

- BP-GL65/GL95/L60S Lithium-ion Battery Pack
- AC power using the AC-550, AC-DN2, AC-DN10 AC adaptor

## Using a battery pack

When a BP-GL65/GL95/L60S Battery Pack is used, the camcorder will operate continuously for the time shown below.

Model name	Operating time
BP-GL65	Approx. 180 minutes
BP-GL95	Approx. 300 minutes
BP-L60S	Approx. 170 minutes

Before use, charge the battery pack with a charger suitable for each battery.

*For details on charging procedure, refer to the battery charger operation manual.*

### Note on using the battery pack

A warm battery pack may not be able to be fully recharged.

## To attach the battery pack

- 1 Press the battery pack against the back of the camcorder, aligning the line on the side of the battery pack with the matching line on the camcorder.

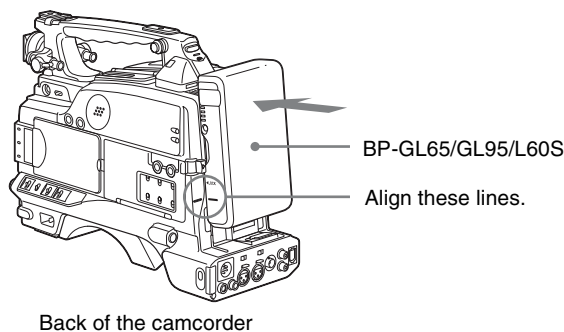

- 2 Slide the battery pack down until its "LOCK" arrow points at the matching line on the camcorder.

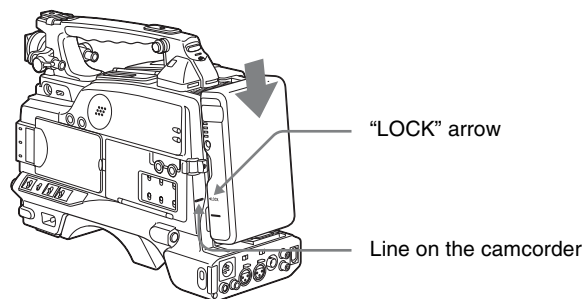

## To detach the battery pack

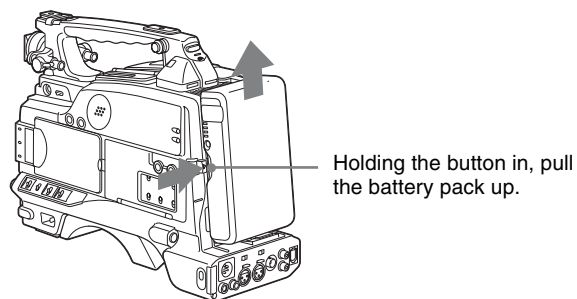

### Notes

- During recording, playback, and loading/unloading a tape, be careful never to remove the battery pack.
- Make sure to turn the camcorder off before changing the battery (except when using an AC-550 and an AC-DN2/DN10 AC adaptor together).

## Using an AC adaptor

### To use the AC-550 AC adaptor

Connect the camcorder to the AC power supply through an AC-550 AC Adaptor as shown in the following figure, and turn the POWER switch of the AC-550 on.

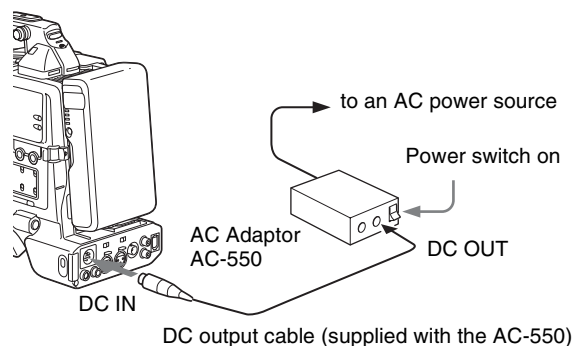

### To use the AC-DN10 AC adaptor

Mount an AC-DN10 on the camcorder in the same way as a battery pack, then connect to the AC power supply. The AC-DN10 can supply up to 100 W of power.

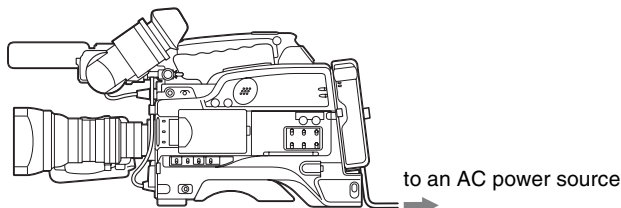

### Avoiding breaks in operation due to an exhausted battery

When the battery pack is becoming exhausted, you can perform battery replacement without causing a break to the camcorder operation by using an AC adaptor.

- 1 Turn the AC-550 AC adaptor on.
- 2 Connect an AC-550 AC Adaptor to an AC power source, then connect it to the DC IN connector of the camcorder (*page 30*).

The power source switches automatically from the battery pack to the AC adaptor connected to the DC IN connector.

#### Note

There may be some noise on the video signal at the time of power source switching.

- 3 Replace the battery pack with a fully charged one.

## Adjusting the Viewfinder

Depending on the eyesight of the operator — whether longsighted or shortsighted — the optimal position of the viewfinder image varies. Adjusting brightness, contrast, and so on, improves the visibility of the viewfinder screen. Although these adjustments may make the viewfinder image clearer, they have no effect on the output video signal from the camcorder.

### Fitting the viewfinder

Remove any microphone from the viewfinder beforehand.

- 1 Slide the viewfinder into the holder on the camera, then tighten the viewfinder left-to-right position fixing ring.

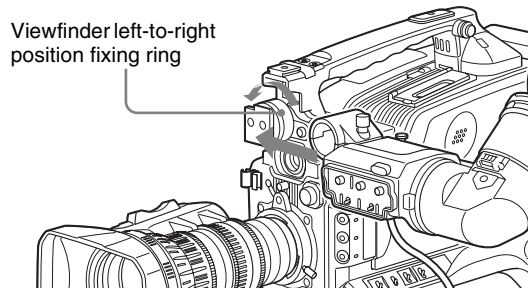

- 2 Connect the viewfinder connector to the VF connector.

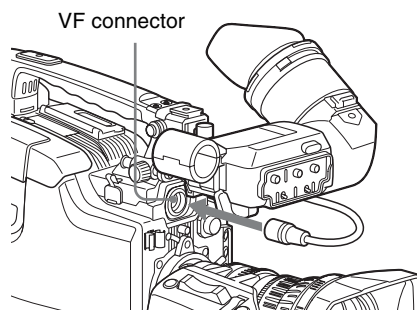

#### Note

Push the connector all the way into the VF connector.

### To remove the viewfinder

Reverse the fitting procedure. Please note that you should slide the viewfinder out while pulling the viewfinder stopper up.

## To use the camcorder with your left eye

By fitting a left eye adaptor to the DXF-801, you can use the camcorder with your left eye to the viewfinder.

### Note

You cannot stow the camcorder in the carrying case with the left-eye adaptor attached.

For details, consult your Sony dealer.

## Adjusting the viewfinder position

To adjust the viewfinder left-to-right position, loosen the left-to-right fixing ring, and to adjust the front-to-back position, loosen the front-to-back position locking knob.

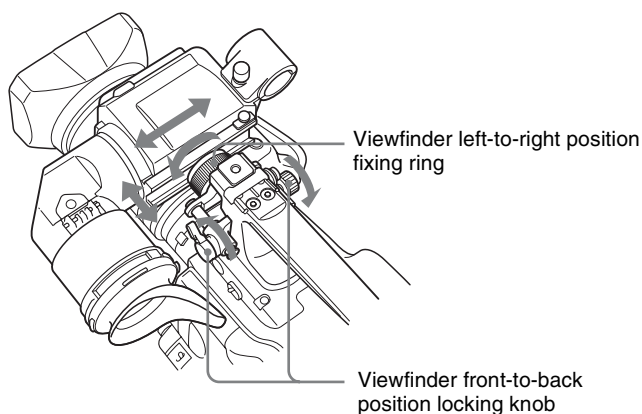

## Adjusting the eyepiece focus and the screen (brightness, contrast, and outline emphasis)

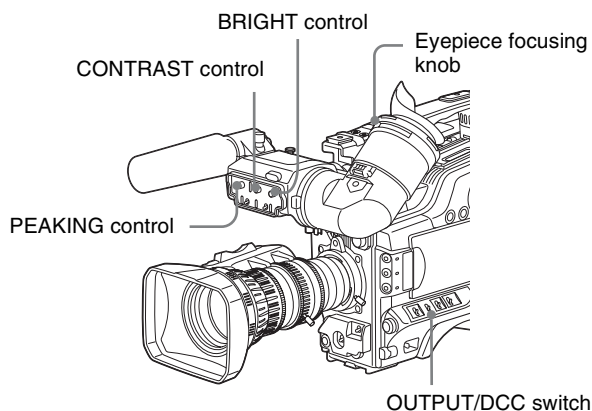

## To adjust the eyepiece focus

First focus the image with the lens, then adjust the eyepiece focusing knob to get the clearest viewfinder

image for your eyesight. The adjustment range is from  $-3$  to  $0$  diopters.

Using an optional part of the DXF-801 allows you to modify the adjustment range to  $-2$  to  $+1$  diopters or  $-0.5$  to  $+3$  diopters.

For details, consult your Sony dealer.

## To adjust contrast and brightness

Carry out these adjustments with the color bars displayed.

- 1 Set the OUTPUT/DCC switch to the BARS position.  
The color bars appear in the viewfinder.
- 2 Watching the color bars, turn the CONTRAST and BRIGHT controls to adjust the contrast and brightness.
- 3 Return the OUTPUT/DCC switch to its original position.

## To adjust the outline emphasis

Turning the PEAKING control changes the degree of outline emphasis in the viewfinder image, to make focusing easier.

## Attaching a 5-inch electronic viewfinder

You can attach an optional DXF-51 (5-inch) Electronic Viewfinder. To attach it, an Accessory Shoe Kit (service part number A-8274-968-B) is required.

For details, contact your Sony dealer.

Remove the cover of the grip and attach the shoe and stopper screw (of the Accessory Shoe Kit).

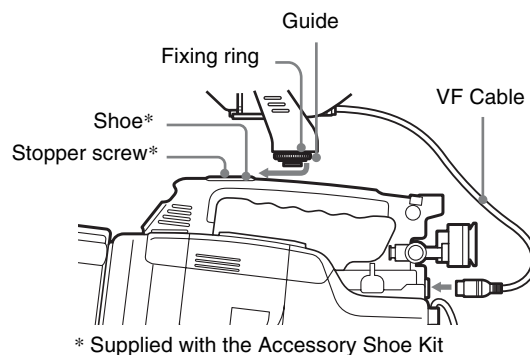



## Using the Shoulder Strap

- 1 Fit one of the clips to a shoulder strap fitting.

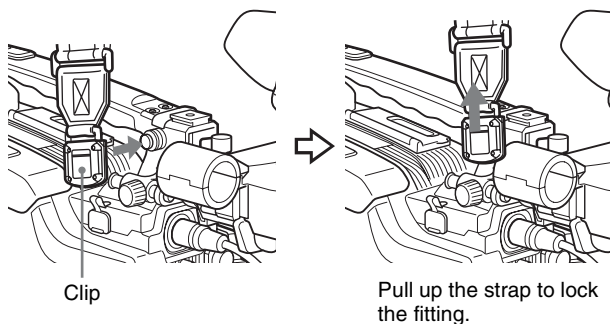

- 2 Fit the other clip to the shoulder strap fitting on the other side of the grip in the same way.

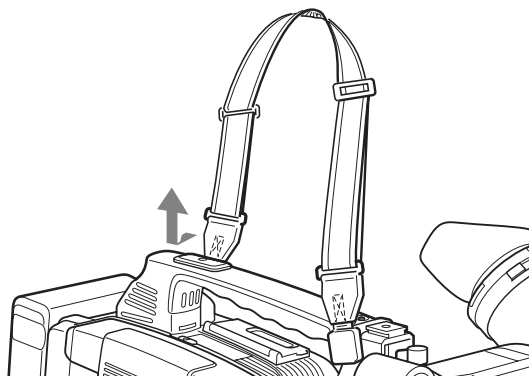

## To remove the shoulder strap

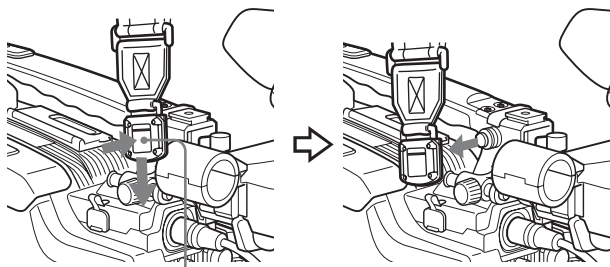

Pull in the direction of the arrow while pressing here.

## Adjusting the Shoulder Pad Position

You can shift the shoulder pad backward or forward by up to 35 mm (1 7/16 inches). This adjustment helps you get the best balance for shooting with the camcorder on your shoulder.

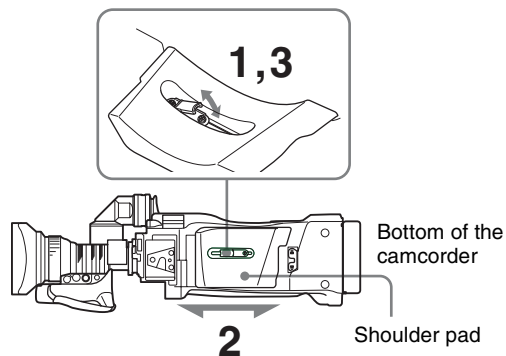

- 1 Raise the lever in the center of the shoulder pad to unlock the shoulder pad.
- 2 Slide the shoulder pad backward or forward until it is in the most convenient position.
- 3 Bring down the lever to lock the shoulder pad in the selected position.

## Fitting to a Tripod

First fit the VCT-U14 Tripod Adaptor to the tripod, then mount the camcorder on the tripod adaptor.

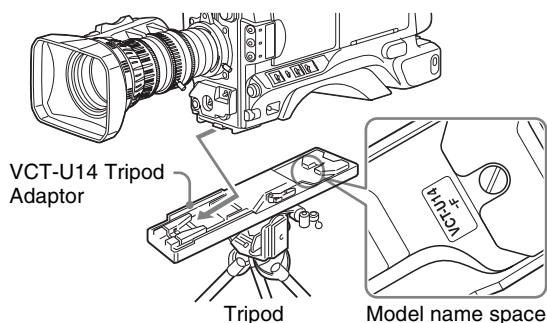

Slide the camcorder forward along the slot, until it clicks firmly into place.

### Note

The camcorder cannot be mounted on a tripod adaptor with one of the following indication, on the model name space, as shown in the above illustration. Use the appropriate tripod adaptor.

- “VCT-U14” only
- “VCT-U14-B”
- “VCT-U14-D”

## To remove a tripod

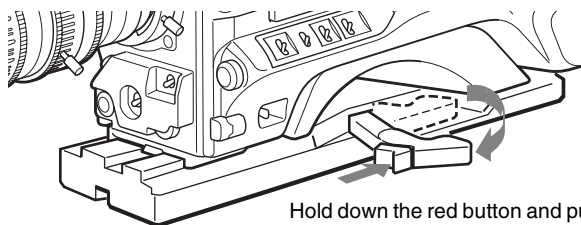

Hold down the red button and pull the lever in the direction of the arrow.

### Note

After removing the camcorder, if the tripod adaptor pin has not returned to its original position, hold down the red button and move the lever in the direction of the arrow to return the pin to its original position. It is not possible to mount a camcorder with the pin left out.

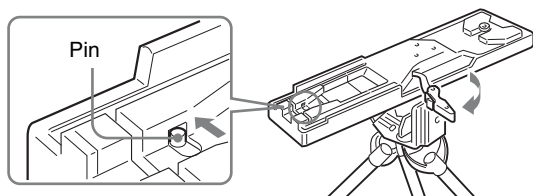

## Using a Video Light

You can use the Anton Bauer Ultralight 2 or equivalent for this camcorder. Use a video light powered by 12 V with maximum power consumption of 50 W.

- If you connect the video light to the LIGHT connector on the camcorder and set the LIGHT switch to AUTO, you can turn the light on and off automatically as you start and stop the VTR operation.
- The output of the video light connector on the camcorder is controlled to 12 V even when the camcorder is supplied with 12 V or more power (through the DC IN connector or battery pack). The brightness or color temperature of the light will not change according to voltage increase.

### Notes

- Do not use a video light with power consumption of over 50 W.
- The brightness or color temperature of the light will change when the supplied voltage (through the DC IN connector or battery pack) is under 12 V.

## To attach the video light

Fit the video light to the camcorder grip or the accessory shoe and connect the video light cable to the LIGHT connector.

# Preparing Audio Input System

## Using the supplied microphone

- 1 Loosen the screw and open the microphone holder clamp.

Clamp of the microphone holder

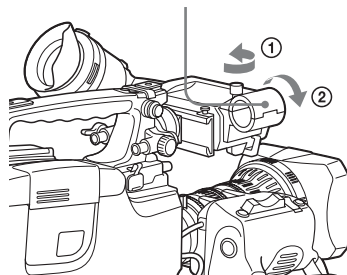

- 2 Place the microphone in the microphone holder.

③ Tighten the screw.

Close the microphone holder.

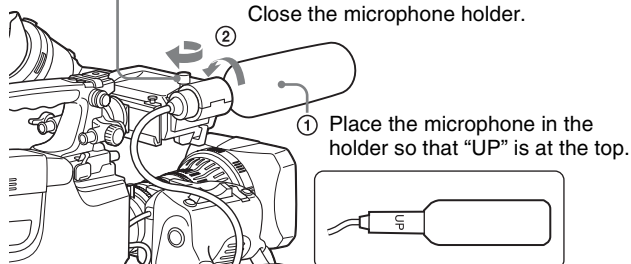

- 3 Plug the microphone cable into the MIC IN connector, then set the AUDIO IN (CH-1/CH-2) switch for the desired recording channel to FRONT.

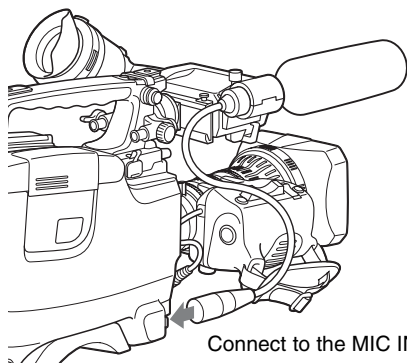

Connect to the MIC IN connector.

## To use the microphone detached from the camcorder

You can use the supplied microphone detached from the camcorder.

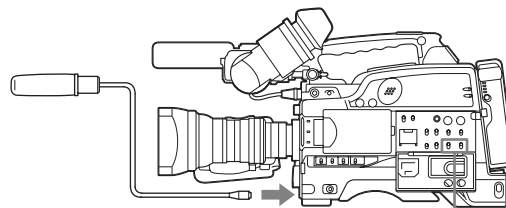

Connect to the MIC IN connector.

Set the AUDIO IN (CH-1/CH-2) switch for the desired audio recording channel to FRONT.

### Note

When using the supplied microphone with an extension cable, always use an external power supply type cable.

## Using an external microphone

You can connect up to two external monaural microphones to the AUDIO IN CH-1/CH-2 connectors, using a CAC-12 Microphone Holder (not supplied).

The procedure below is an example showing attachment of an ECM-670/672/etc. Electret Condenser Microphone.

- 1 Remove the fixing screws for external microphone holder.

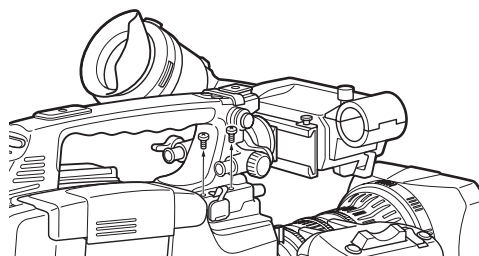

- 2 Attach the CAC-12 Microphone Holder.

Screws removed in step 1

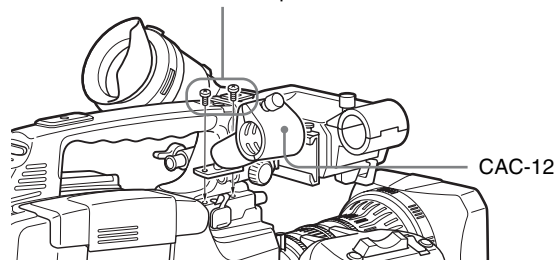

CAC-12

- 3 Open the CAC-12 and remove the microphone adaptor.

Use the microphone adaptor when using a small-diameter external microphone. When attaching an ECM-670, use the microphone adaptor supplied with these microphone.

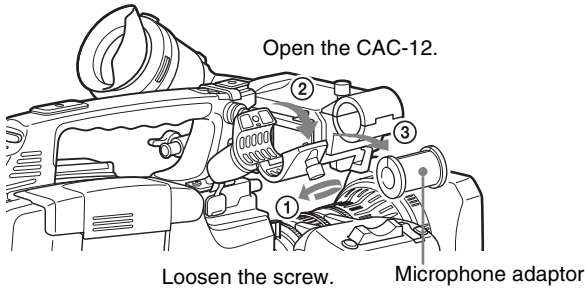

- 4** Place an external microphone (ECM-670/672/etc. Electret Condenser Microphone or similar microphone) in the CAC-12.

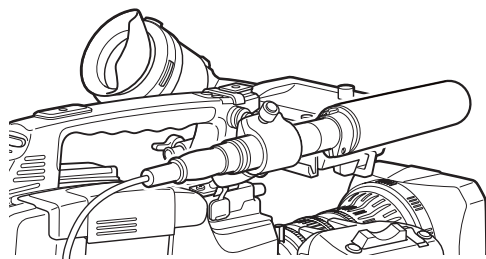
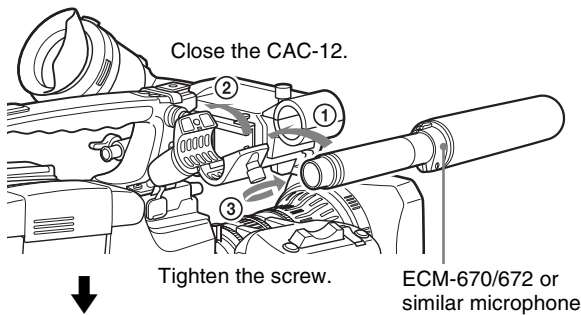

- 5** Connect the microphone cable to the AUDIO IN CH-1 or CH-2 connector.

- 6** Set the switches as follows.

- Set the AUDIO IN input selection switch as indicated below, depending on the type of microphone used.
  - When using a microphone with an internal power supply, set it to MIC (center).
  - When using a microphone with an external power supply, set it to MIC +48V ON (right).
- Set the AUDIO IN (CH-1/CH-2) switch of the channel that the microphone is connected to REAR.

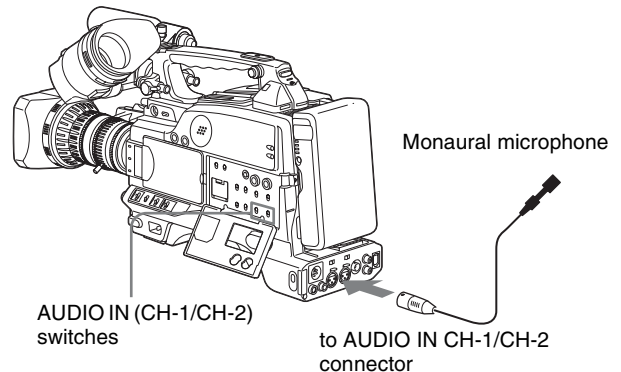

#### Notes

- The camcorder can use a microphone with an input level of  $-60$  dB. Other microphones may not be suitable for use with this camcorder due to differences in the input level.
- In order for the AUDIO IN CH-1 and CH-2 connectors on the camcorder to be able to provide a phantom 48 V power supply, female XLR connectors (3-pin) are fitted. If the microphone cable has a female connector, use an adaptor.
- When you detach a CAC-12 Microphone Holder once you have attached to the camcorder, be careful not to lose the two screws fixing the CAC-12. After detaching the CAC-12, be sure to put the two screws back into their original places.

## Attaching a UHF Portable Tuner (for a UHF Wireless Microphone System)

You can use the wireless microphone system including following models to record sound.

- UHF Wireless Microphone
  - NTSC system: WRT-807B, WRT-847B
  - PAL system: WRT-807A/B, WRT-847A/B
- UHF Synthesized Transmitter
  - NTSC system: WRT-8B, WRT-822B
  - PAL system: WRT-8B, WRT-822A/B
- UHF Synthesizer Tuner
  - NTSC system: WRR-855B, WRR-861B, WRR-862B
  - PAL system: WRR-855A/B, WRR-861A/B (in Australia and Asia only), WRR-862A/B

For details on using the wireless microphone system, see the operating instructions for the microphone and tuner.

## To attach a WRR-855

- 1 Open the cover of the WRR connector.

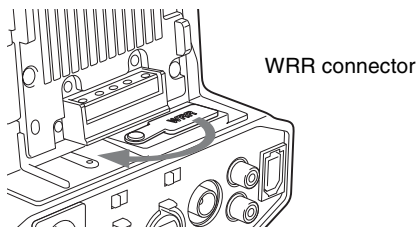

- 2 Turn on a WRR-855, and set the MUTING to ON or OFF.

The power of a WRR-855 can be synchronized with the POWER switch of the camcorder.

- 3 Insert the WRR-855 into the CA-WR855.

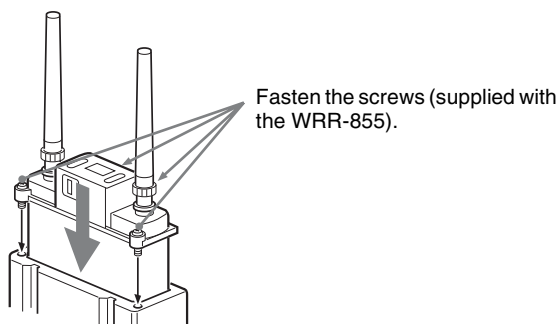

- 4 Fit the attachment plate on the rear side of the CA-WR855 to the V-groove on the battery attachment interface, and then slide the CA-WR855 down until it connects to the WRR connector.

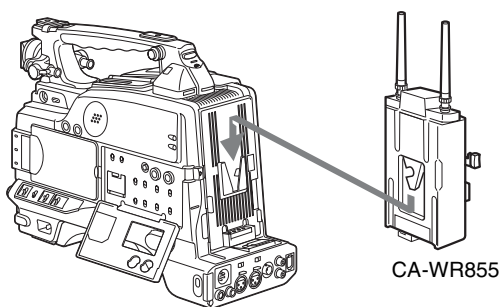

- 5 Set one of the AUDIO IN (CH-1/CH-2) switches to WRR (wireless).

## To attach a WRR-861/862 (When using a BP-GL65/GL95/L60S Battery Pack)

- 1 Attach a WRR tuner fitting (not supplied, service part number A-8278-057-A) to the back of the camcorder.
  - ① Use a Phillips type screwdriver to tighten the four screws placed in the tuner fitting as illustrated below.

### Note

Make sure that the four screws are fully tightened.

- ② Loosen the adjustment screws of the tuner fitting.
- ③ Adjust the tuner fitting position for a BP-GL65/GL95/L60S Battery Pack to be attached, and tighten the adjustment screws to fix its position.
- ④ Attach the mount plate supplied with the WRR-861/862.

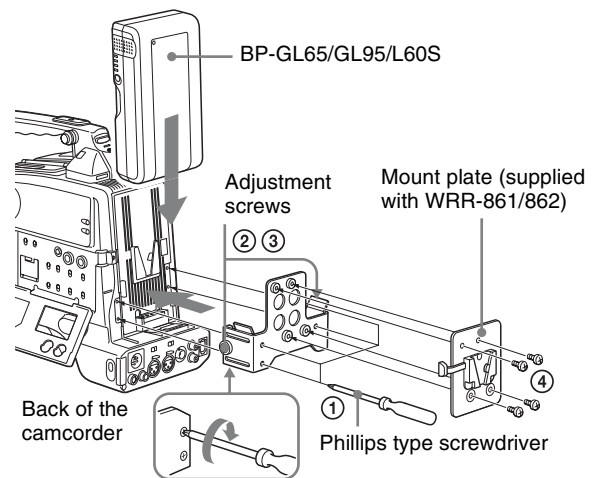

- 2 Attach the battery pack.

For details about attaching the battery pack, see "Using a battery pack" on page 30.

- 3 Mount the tuner on the WRR tuner fitting.

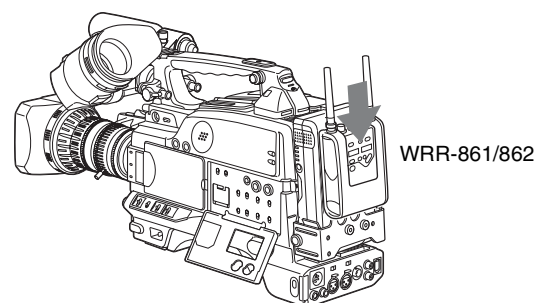

For details about the WRR tuner fitting (service part number A-8278-057-A), contact your Sony service representatives.

- 4 Connect the tuner power cord to the DC OUT connector of the camcorder, and the audio output cable to the AUDIO IN CH-1 or CH-2 connector.
- 5 Set the switches as below.
  - Set the AUDIO IN input selection switch to MIC for the channel to which the audio out cable is connected.
  - Set the AUDIO IN (CH-1/CH-2) switch for the channel to which the audio output cable is connected to REAR.

## Connecting line input audio equipment

- 1 Connect an audio mixer or other external audio system component to the AUDIO IN CH-1/CH-2 connector as shown below.

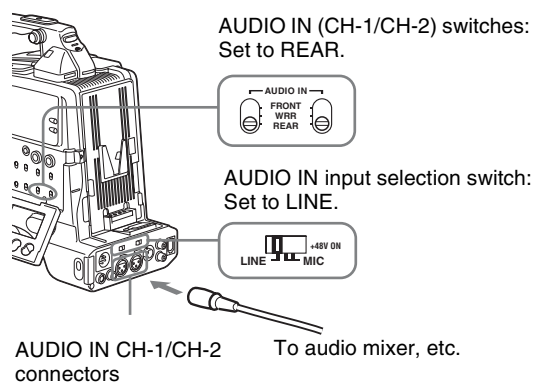

- 2 Set the AUDIO IN input selection switch to LINE for the channel to which the external audio equipment is connected.

### Selection of the recording audio input

Set the AUDIO IN (CH-1/CH-2) switch to REAR for the channel to which the external audio equipment is connected.

If you record and adjust both channel 1 and 2, set both AUDIO IN (CH-1/CH-2) switches to REAR.

## Connecting the Remote Control Unit (DSR-450WS/450WSP only)

Connecting the RM-B150/B750 Remote Control Unit enables remote control of the principal camera and VTR functions.

Connecting the remote control unit to the REMOTE connector (8-pin) automatically puts the camcorder into remote control mode. If you disconnect the remote control unit, the remote control mode is cancelled.

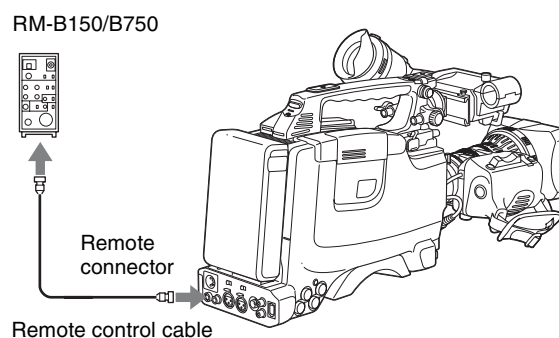

### Note

Before connecting or disconnecting the camcorder and a remote control unit, turn off the camcorder.

### Camcorder switch functions when the remote control unit is connected

The following switches on the camcorder do not function.

- GAIN switch
- OUTPUT/DCC switch
- WHITE BAL switch
- AUTO W/B BAL switch
- SHUTTER switch
- REC button (the VTR button on the lens and the ASSIGN switch to which the REC SWITCH function is assigned) when the RM REC START item is set to RM on the FUNCTION 3 page of the MAINTENANCE menu.

*For details of the function of the REC button, see "Function of the REC button when the remote control unit is connected" on page 39.*

### Paint adjustment when the remote control unit is connected

The settings of the paint adjustment that were in effect the last time the remote control unit was used are recalled.

## Function of the REC button when the remote control unit is connected

You can select the function of the REC button on the camcorder when the remote control unit is connected, using the RM REC START item on the FUNCTION 3 page of the MAINTENANCE menu.

### To disable the camcorder REC button and the lens VTR button

On the FUNCTION 3 page of the MAINTENANCE menu, set RM REC START to RM.

If the REC SWITCH function is assigned to the ASSIGN switch, this setting also disables these controls.

### To enable the camcorder REC button and the lens VTR button

On the FUNCTION 3 page of the MAINTENANCE menu, set RM REC START to CAM.

If the REC SWITCH function is assigned to the ASSIGN switch, this setting also enables these controls. In this case, the VTR button on the remote control unit is disabled.

### To enable all of the camcorder REC button, the lens VTR button, and the remote control unit VTR button

On the FUNCTION 3 page of the MAINTENANCE menu, set RM REC START to PARA.

If the REC SWITCH function is assigned to the ASSIGN switch, this setting also enables these controls.

## When the monitor is connected to the remote control unit

The MONITOR connector (BNC type) of the RM-B150/B750 outputs the same signal as that from the MONITOR OUT connector on the camcorder.

Use the black cable supplied with the RM-B150/B750 to connect the monitor to the MONITOR connector on the RM-B150/B750.

## When the remote control unit is disconnected from the camcorder

The camcorder settings return to the settings in effect before the remote control unit was connected.

By making a menu setting, the setting of the paint adjustment made with the remote control unit can be retained even after the remote control unit is removed from the camcorder.

*For details, see “To use settings of the paint adjustment data stored in the “independent data region” even when a remote control unit is connected” on page 40.*

## Structure of the paint adjustment data

The non-volatile memory of the camcorder used for storing paint adjustment data consists of two regions as shown below: one is the “independent data region” that is used when a remote control unit is not connected, and the other is the “remote control data region” that is used when a remote control unit is connected. Paint adjustment data is automatically selected and output to the camcorder depending on whether or not a remote control unit, such as an RM-B150, is connected.

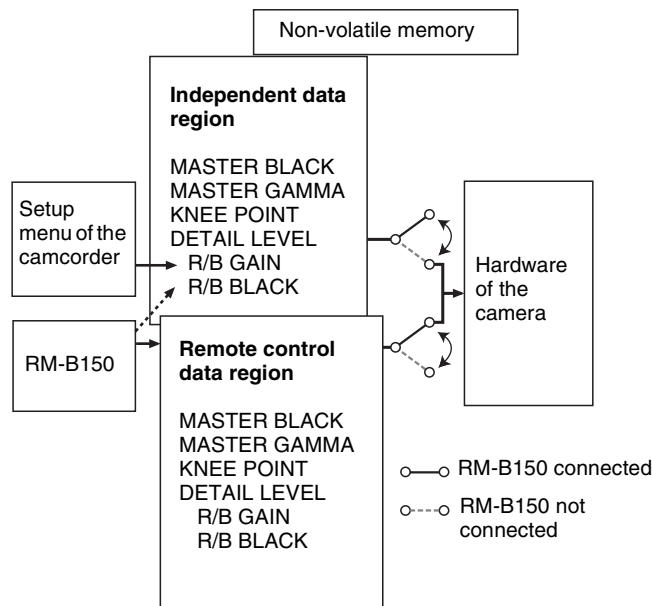

Thus, when a remote control unit is connected to the camcorder, the effective data region is switched to the “remote control data region” and the settings of the paint adjustment that were in effect last time the remote control unit was used are recalled.

Settings of the absolute value volume <sup>1)</sup> and absolute value switches <sup>2)</sup> are overwritten by those on the remote control unit after the remote control unit is connected.

When the remote control unit is removed from the camcorder, the “independent data region” becomes effective. Thus the camcorder will return to the settings that were in effect before the remote control unit was connected.

- 1) **Absolute value volume:** The data corresponding to the rotation degree (position) of the volume knob is output. The data corresponding to the rotation amount (change) is called the relative value volume.
- 2) **Absolute value switch:** Toggle switches or slide switches (except the temporary switches) (or controls) whose positions must coincide with their functions are called absolute value switches.

**To use settings of the paint adjustment data stored in the “independent data region” even when a remote control unit is connected**

Set RM COMMON MEMORY to ON on the FUNCTION 3 page of the MAINTENANCE menu.

In this case, the settings stored in the “independent data region” will be renewed according to the change made by remote control unit. Thus, the settings of the paint data made with the remote control unit can be retained even if the remote control unit is removed. However, if the switch position on the remote control unit differs from the one on the camcorder, the switch position on the camcorder takes precedence over that on the remote control unit.

*For details on menu operations, see “Basic menu operations” on page 94.*

**To avoid changing video adjustment data when a remote control unit is connected**

Set RM COMMON MEMORY to ON on the FUNCTION 3 page of the MAINTENANCE menu, and set all the volume on the remote control unit to the relative value mode.

*For details, refer to the operation manual supplied with the remote control unit.*



## Connecting a Monitor

As illustrated below, you can connect a color video monitor to the MONITOR OUT or VIDEO OUT connector of the camcorder.

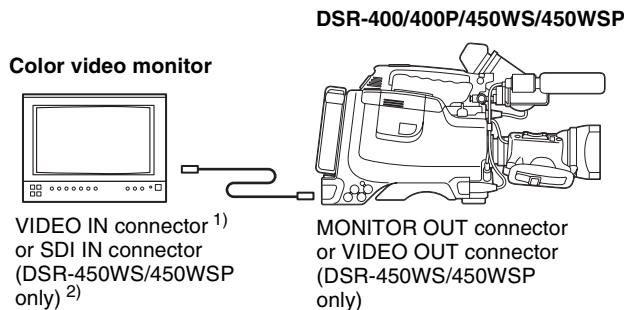

- 1) When VBS is selected as the output signal of the VIDEO OUT connector  
2) When SDI is selected as the output signal of the VIDEO OUT connector  
(only when a CBK-SD01 is installed)

### When a CBK-SD01 SDI Output Board is installed (DSR-450WS/450WSP only)

If a color video monitor provided with an SDI input connector is used, select SDI as the output signal of the VIDEO OUT connector and connect the camcorder to the SDI IN connector of the color video monitor.

The camera display image is output to the CBK-SD01 SDI Output Board even when playing a recorded image.

#### Notes

- When connecting the camcorder to an external equipment using the VIDEO OUT connector or the MONITOR OUT connector, terminate the connecting cable. If the cable is not terminated, the picture will not be output from the camcorder to the external equipment.
- Playing the tape on the camcorder mutes the audio signal portion of the SDI output.
- You can select either VBS or SDI for the output signal of the VIDEO OUT connector, depending on the input connector used on the monitor. See 1) and 2) in the illustration above.

*For details about settings, see “Selecting the output signals (DSR-450WS/450WSP only)” on page 105.*

*The items displayed on a monitor are same as the ones on the viewfinder. For details, see “Status display on the viewfinder screen” on page 22.*

## Using an i.LINK Connection

Using the **i** (i.LINK) DV OUT connector, you can connect external recording equipment to the camcorder. In this section, connections to equipment using DVCAM or DV format are explained.

### Note

Depending on the equipment connected, you may be able to record in a format different from that of the camcorder. However, the recording function using different formats is limited.

For details, see "Usable cassettes" on page 48.

## Settings required for an i.LINK connection

When connecting via an i.LINK cable (DV cable), change the following settings depending on the connection.

### i.LINK CTL setting

Selects whether or not to control recording (start and stop) on the external equipment connected to the **i** (i.LINK) DV OUT connector from the camcorder. Select the setting from the following on the FUNCTION 3 page of the MAINTENANCE menu. The factory setting is REC/P.

**ALL:** An external equipment is controlled from the camcorder while it records, pauses, or stops.

**REC/P (REC/PAUSE):** An external equipment is controlled from the camcorder while it records or pauses.

**OFF:** No control from the camcorder.

### REC TRIGGER switch

Sets the function of the REC button on the camcorder or the VTR button on the lens when an external VTR is connected to the **i** (i.LINK) DV OUT connector. Set to INT ONLY when you need to do cut editing or making a copy of a tape using the **i** (i.LINK) DV OUT connector. **PARALLEL:** Operates both internal and external VTRs simultaneously.

**INT ONLY:** Operates the internal VTR only. External VTR operation is performed locally.

**EXT ONLY:** Operates the external VTR only. The TALLY indicator on the camcorder lights up when the external VTR is in recording mode.

### Note

When there is no equipment connected to the **i** (i.LINK) DV OUT connector on the camcorder, the setting of the REC TRIGGER switch does not affect the internal VTR.

## Making a backup of the images being recorded

The audio and image being recorded can be backed up on an external VTR through i.LINK, at the same time it is being recorded on the camcorder.

### Example of connection

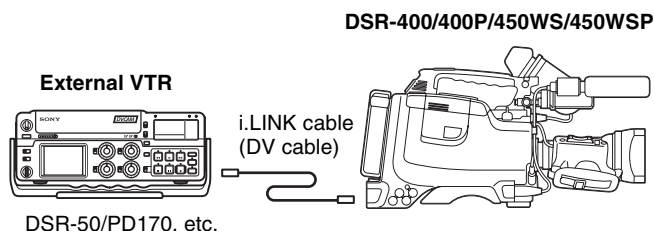

### Note

When the scan mode is 24P, video images, audio, or time code output via the i.LINK connection may not be continuous (DSR-450WS only).

## To record the same material using the internal VTR of the camcorder and on an external VTR simultaneously

- 1 Set the REC TRIGGER switch to PARALLEL.
- 2 Check the settings of an external VTR and set the i.LINK CTL to the same settings.
- 3 Press the REC button.

Recording starts on both the internal VTR of the camcorder and the external VTR.

### Note

If recording on the camcorder and the external VTR starts at the same time, the recording starting points differ because of variation due to the external VTR connected. Also, it is recommended that you use internal mode as the time code generator mode for an external VTR. If you synchronize the time code generator of the camcorder using external mode, the time code may not be continuous.

## To record by clip using the internal VTR while simultaneously recording on an external VTR

While recording material consecutively by time on an external VTR, the material needed for editing can be recorded clip by clip using the internal VTR of the camcorder.

- 1 Set the REC TRIGGER switch to INT ONLY.
- 2 Press the recording button of the external VTR.  
Recording starts on the external VTR.
- 3 Press the REC button on the camcorder.  
Recording starts on the internal VTR. Pressing the REC button switches between recording and pausing using the internal VTR.

## To check the playback image recorded on an external VTR

You can check the playback image recorded on an external VTR that is connected to the camcorder for backup.

- 1 Connect the camcorder to the external VTR using an i.LINK cable (DV cable).
- 2 Set the REC TRIGGER switch to PARALLEL or EXT ONLY.
- 3 Press the STOP button on the camcorder to set the internal VTR of the camcorder to stop mode, or press the EJECT button to eject the cassette.
- 4 Start playback on the external VTR.

The i.LINK on the camcorder changes to input mode, and the playback image from the external VTR is displayed on the viewfinder and the LCD monitor, and through the MONITOR OUT connector.

### Notes

- The i.LINK on the camcorder changes to input mode only when the connected external equipment is played back. (When the REC TRIGGER switch is set to INT ONLY, the i.LINK does not change to input mode.)
- The playback image from the external VTR cannot be recorded using the internal VTR of the camcorder.
- Depending on the external equipment connected, the playback image may be overlapped or skipped over if the playback signal contains jitter. However, this is not a malfunction.

- In order to check the video image when a DSR-1500A/1800A/2000A or similar equipment is connected to the camcorder, it is necessary to set the input to a setting other than i.LINK. When the input is set to i.LINK, i.LINK is only used for input and no signal is output via the i.LINK connection. Therefore, a gray image is displayed on the camcorder.

## Using the camcorder as a feeder

### To copy digitally from the camcorder to the VTR without the editing function

Using an i.LINK cable (DV cable) to connect a digital video cassette recorder with an i.LINK connector to the camcorder, digital copy of video and audio can be carried out.

#### Example of connection

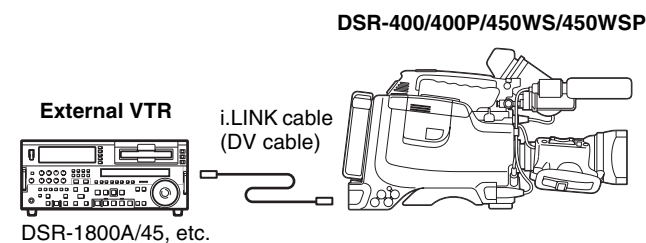

- 1 Make the settings below to prepare the external VTR.
  - Set REC MODE to the same recording mode as that of the camcorder.
  - In NTSC color system, when the recording mode is set to DVCAM, select either DF or NDF.
  - Set AUDIO MODE to either 4-channel or 2-channel mode, according to the tape that is played on the camcorder.
- 2 Pause recording on the external VTR.
- 3 Play the tape on the camcorder.
- 4 Check the playback on the camcorder, and when playback reaches the scene that you want to record, start recording again on the external VTR.  
  
The copy to the external VTR starts.
- 5 When copy to the external VTR is finished, release the recording pause on the external VTR, and then stop playback of the tape on the camcorder.

*For details on the external VTR, see the instruction manual supplied with the external VTR.*

## To control the camcorder from the VTR using the editing function

By connecting a VTR with an i.LINK connector to the i.LINK (i.LINK) DV OUT connector of the camcorder using an i.LINK cable (DV cable), you can control playback and recording of the camcorder and perform cut editing and digital copy.

### Example of connection

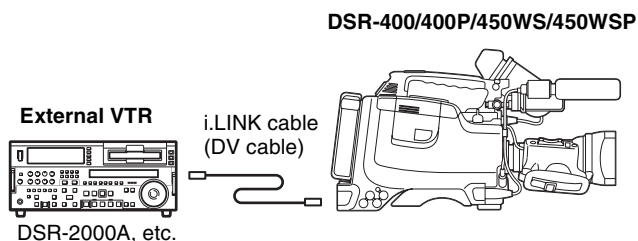

- 1 Set the REC TRIGGER switch to INT ONLY.
- 2 Make the settings below to prepare the external VTR.

When using DSR-2000A, press the i.LINK button on the remote control setting section.

#### Note

To use the automatic copying function of DSR-2000A, it is necessary to set the recording format of the camcorder to DVCAM on the VTR MODE page of the MAINTENANCE menu.

*For details on the external VTR, see the instruction manual supplied with the external VTR.*

## To control the camcorder from a non-linear editing system

Using the i.LINK cable (DV cable), you can transfer video and audio signals to a non-linear editing system from the camcorder. Editing software that supports the selected recording format (DVCAM or DV) must be used.

### Example of connection

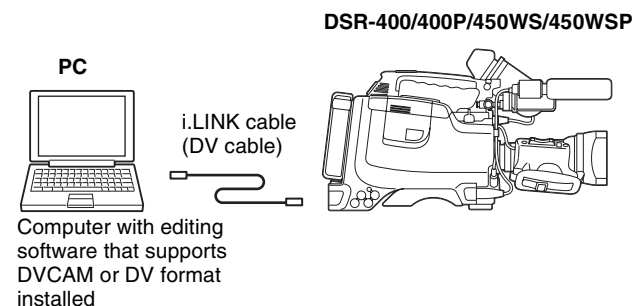

- 1 Set the REC TRIGGER switch to INT ONLY.
- 2 Operate the PC to set up the non-linear editing software.

*For details, see the software's manual.*

#### Notes

- Video edited using a non-linear editing system cannot be recorded on tape using the camcorder via an i.LINK cable (DV cable).
- A tape recorded with a non-continuous time code may not be able to be captured frame by frame using a non-linear editing system.

# Other Connections

## Connecting a number of camcorders

When using two or more synchronized camcorders, connect an external sync signal to the GENLOCK IN connector, supplying a VBS or BS signal. The camcorder will then operate synchronized to this signal.

You can adjust the synchronization using the GENLOCK page of the MAINTENANCE menu.

When a CBK-SD01 SDI Output Board is installed in the DSR-450WS/450WSP, it is necessary to set REAR BNC OUT SEL to VBS on the OUTPUT page of the OPERATION menu.

### Notes

- When a CBK-SC01 Composite Input Board (not supplied) is installed, set REC VIDEO SOURCE to CAM on the SOURCE SEL page of the OPERATION menu.
- When connecting a number of camcorders and synchronizing their time codes, wait until the reference camcorder becomes stable (a state where a normal picture appears on the viewfinder or the LCD monitor), and then connect the other camcorders.

### Example 1: When camcorder 2 is synchronized with the signal of camcorder 1

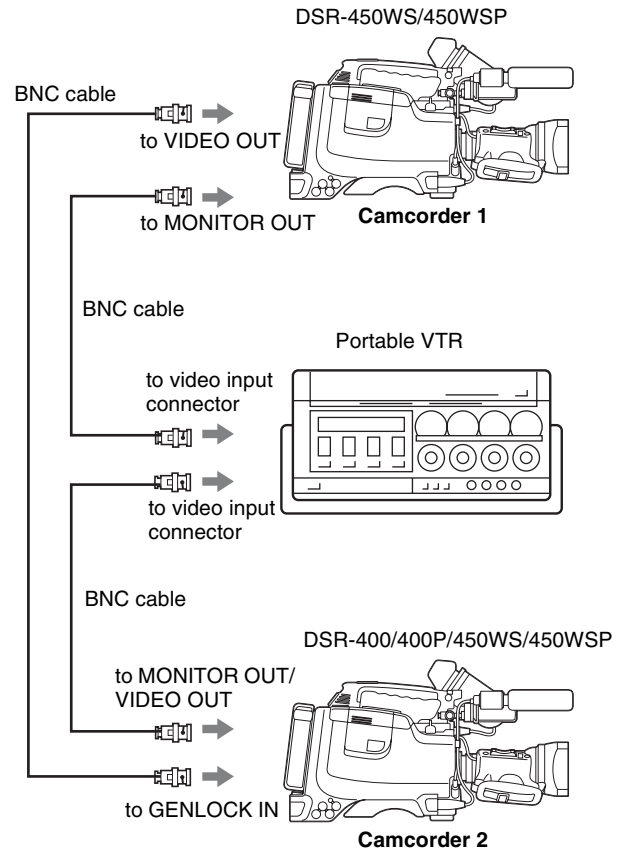

### Example 2: When camcorder 1 and 2 are synchronized with the signal of a DME switching device, etc.

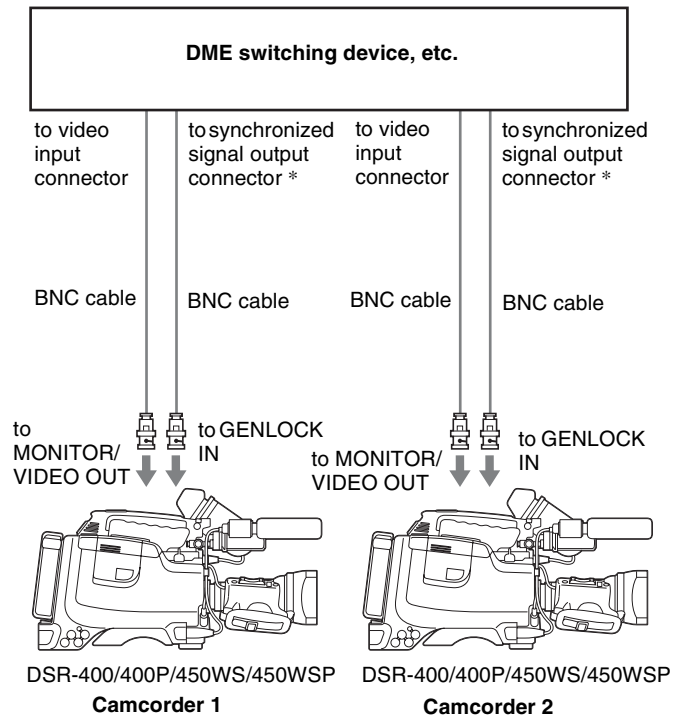

\* Either the BB (Black Burst) signal or the Color Bar signal, etc. can be used as a synchronized signal.

## Inserting a Cassette

The camcorder can use standard-size and mini-size DVCAM/DV cassettes. For details about usable cassette, see “Usable cassettes” on page 48.

- 1 Set the POWER switch to ON.
- 2 While sliding the OPEN lever in the direction of the arrow, open the cassette lid.

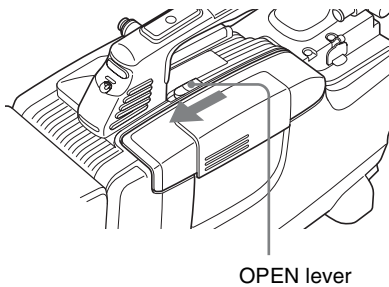

OPEN lever

- 3 Insert the cassette with the cassette window (on the front) facing outward and the REC/SAVE switch facing upward.

Check for tape slack before inserting the cassette.

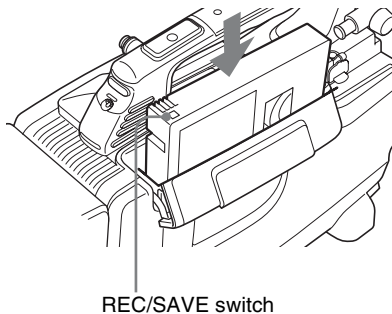

REC/SAVE switch

Press the center of the cassette.

### To insert a mini-size cassette

Insert the cassette with the cassette window (on the front) facing outward. Push the cassette between the both guides.

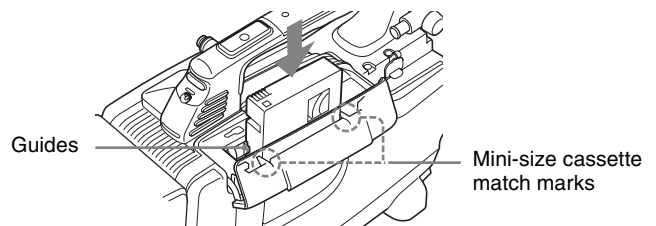

- 4 Close the cassette lid until it clicks.

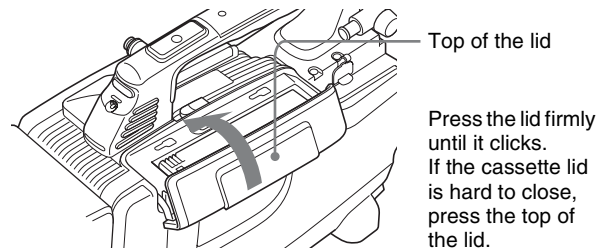

Top of the lid

Press the lid firmly until it clicks. If the cassette lid is hard to close, press the top of the lid.

### To eject a cassette

Follow the procedure above, and take out the cassette by pressing the EJECT button in step 3.

#### Notes

- Before inserting a cassette, make sure that there is no cassette in the cassette compartment. Inserting two cassettes by mistake may cause a malfunction.
- Internal parts of the camcorder may become bent or otherwise damaged if you attempt to insert a mini-size cassette in the wrong direction (such as with the cassette turned backside front so the reel holes face the cassette holder window or with the cassette turned sideways so that a short side enters first).
- If a cassette is not inserted completely or gets stuck when being inserting, take out the cassette and reinsert it. If you insert a cassette forcibly, the cassette may not be

inserted in the correct position or may cause a malfunction.

- When inserting a cassette, hold the center of the cassette and insert it straight toward the compartment. **Holding the side of the cassette may cause it to be inserted incorrectly.**
- When inserting a cassette, put the camcorder on a horizontal and stable surface.

## Basic Procedure for Shooting

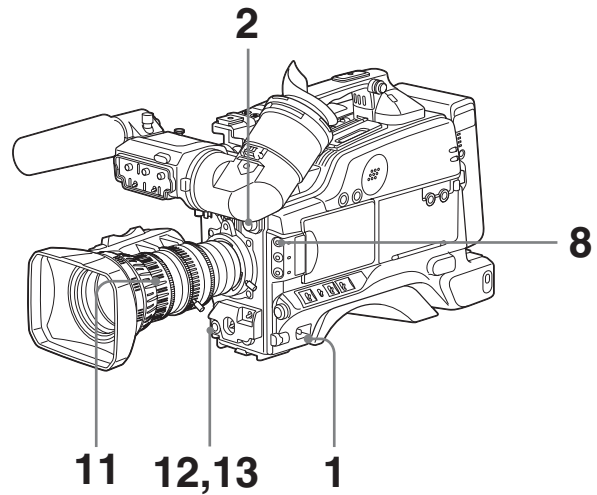

- 1 Set the POWER switch to ON.
- 2 Set the FILTER selector and the 5600K button appropriately for the lighting conditions.

FILTER selector setting	Examples of shooting conditions
1 (CLEAR)	Studio halogen lighting (incandescent)
2 (1/4 ND)	Cloudy or rainy outdoor shooting, or to reduce the depth of field*
3 (1/16 ND)	Sunlight
4 (1/64 ND)	To reduce the depth of field in sunlight

\* The range over which the subject is sharply in focus. Thus, “reducing the depth of field” means that the range is reduced as well, and “increasing the depth of field” means that it is increasing as well.

- 3 Check the switch settings on the camcorder.
- 4 Check the settings in the menu.
- 5 Check the lens settings and flange focal length adjustment (*page 29*).
- 6 Adjust the eyepiece focus, and the contrast and brightness of the viewfinder image (*page 32*).
- 7 Check the sound system settings.
  - Microphone connections (*page 35*)
  - Settings on the VTR section (*page 15*)

- 8** If required, switch on the center marker and/or safety zone in the viewfinder image.

For details, see “Setting the marker display” on page 101.

Also, press the ZEBRA button to display zebra pattern in the viewfinder.

- 9** If necessary, adjust the white balance and black balance (page 51).

- 10** If necessary, adjust the iris and gain.

For details about the adjustment of iris, see “Iris ring” on page 20, “Instant automatic iris adjustment button” on page 20, and “Adjusting the iris” on page 56.

For details about the adjustment of gain, see “GAIN switch” on page 12, and “Setting gain values for the GAIN switch positions” on page 104.

- 11** Turn the focusing ring so that the subject is sharply in focus.

- 12** Setup the VTR section according to your shooting objects, then start recording by pressing the REC button.

- During recording, the REC/TALLY indicator(s) in the viewfinder light(s), and “REC” appears on the viewfinder screen.
- You can use the AUDIO LEVEL knob on the front of the camcorder to manually adjust the channel 1 audio level. To do this, you must first set up the VTR section to enable manual adjustment of the audio recording level (page 58).

- 13** To pause recording, press the REC button again.

## Recording

### Usable cassettes

It is recommended to use the DVCAM cassettes listed below for this camcorder.

Model name	Size
PDV-184*/124*/94*/64*/34*	Standard size
PDVM-40*/32*/22*/12*	Mini size

The “\*” in each model name is actually “ME” (indicating that a cassette memory is contained), or “N” (indicating that no cassette memory is contained).

The numbers in the model names show maximum recording/playback time (minutes) for each model. For example, the maximum recording/playback time of the PDV-184\* is 184 minutes.

#### Note

If you insert an incorrect type of cassette, it will be automatically ejected.

### DVCAM cassettes

The following figure illustrates the DVCAM cassettes’ appearance.

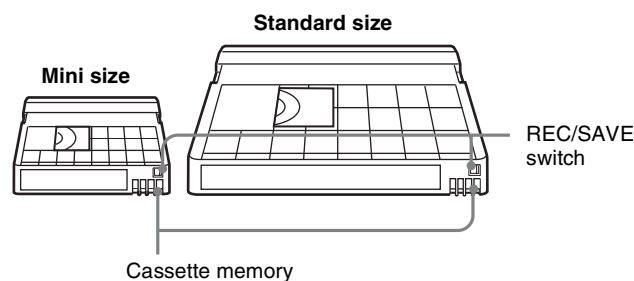

### Notes on using cassettes

- Before storing the cassette, rewind the tape to the beginning and be sure to put the cassette in its storage case, preferably on end instead of flat on its side. The storage case of a DVCAM cassette is specially designed to ensure a long-period storage of the tape. Storing a cassette in any other condition (not rewound, out of its case, etc.) may cause the video and audio contents to become damaged over time.
- If the cassette memory connector (contact point) becomes dirty, connection problems may occur and cause a loss of functions. Remove away any dust or dirt from this area before using the cassette.
- If the cassette is dropped on the floor or otherwise receives a hard impact, the tape may become slackened



and may not record and or play back correctly. For instructions on removing tape slack, see next page.

- Follow the instructions in “Inserting a Cassette” on page 46 to insert a cassette, or the camcorder may be damaged.

### To prevent accidental erasure

Set the REC/SAVE switch to SAVE to prevent accidental erasure of recorded contents.

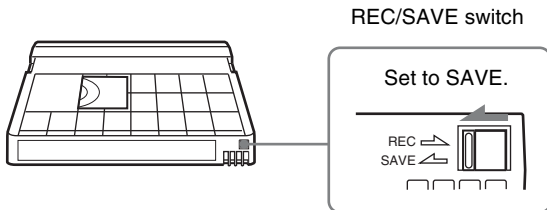

If you insert a cassette into the camcorder when the REC/SAVE switch is set to SAVE, the camcorder will not record when you press the REC button.

### To enable recording

Set the REC/SAVE switch back to REC.

### To check the tape for slack

Turn the reel gently with a paper clip, etc., in the direction shown by the arrow. If the reel does not move, there is no slack. Insert the cassette into the cassette holder, and after about 15 seconds take it out.

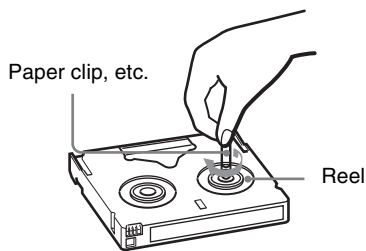

### Compatibility of DVCAM and DV formats

This camcorder can also use the consumer DV format in addition to the DVCAM format (only SP mode is available for DV format, you cannot record/play in LP mode of the DV format). Here explained are the differences, compatibility, and limitations on editing about DVCAM and DV formats.

### Differences between DVCAM and DV formats

Item	DVCAM	DV
Track pitch	15 μm	10 μm
Audio sampling frequency	12 bit: 32 kHz 16 bit: 48 kHz	12 bit: 32 kHz 16 bit: 32 kHz, 44.1 kHz, 48 kHz
Audio recording mode*	Lock mode	Unlock mode
Time code	Drop frame system or Non-drop frame system (SMPTE time code)	Drop frame system (or Non-drop frame system when recording in DV format)

\* There are two modes for audio recording, lock mode and unlock mode. In lock mode, the sampling frequencies of audio and video are synchronized. In unlock mode, which consumer DV format adopts, the two sampling frequencies are independent. Therefore, lock mode is more effective than unlock mode in digital processing and smooth transition during audio editing.

### Note

Audio with sampling frequency 16 bit: 32 kHz and 44.1 kHz cannot be recorded on this camcorder.

### Compatibility on cassettes

The recording format of picture is defined according to recorder’s format as described below.

Recorder’s format	Cassette that is used	Recording format
DVCAM	DVCAM tape DV tape	DVCAM
DV	DVCAM tape DV tape	DV

- Though DV cassettes can be used for recording in DVCAM format, we recommend you to use DVCAM cassettes to get the most out of high reliability of DVCAM format.
- When you record using DV cassettes in DVCAM format, the recording time of DV cassettes is 2/3 shorter than that indicated on the DV cassettes.

### Compatibility on playback

Some tapes cannot be played back on DVCAM or DV video equipment.

Tape	On DV video equipment	On DVCAM video equipment
DV-formatted	Can be played back.	Can be played back only when recorded in SP mode.
DVCAM-formatted	Some equipment may be able to play back.	Can be played back.

## Compatibility on editing using DV connectors

When this digital camcorder is connected to other DVCAM or DV video equipment using DV cable (i.LINK cable), the recording format of edited tapes is defined according to recorder's format as described below. Read through "Limitations on editing" before editing, because you may find the limitations when you use the tapes edited in some conditions.

Source tape	Player's format	Recorder's format	Recording format
DV (only in SP mode)	DVCAM	DVCAM DV	DVCAM <sup>1)</sup> DV
DV	DV	DVCAM DV	DVCAM <sup>1)</sup> DV
DVCAM <sup>2)</sup>	DVCAM	DVCAM DV	DVCAM DV <sup>4)</sup>
DVCAM <sup>2)</sup>	DV <sup>3)</sup>	DVCAM DV	DVCAM <sup>5)</sup> DV <sup>4)</sup>

1) When using the DVCAM video equipment to carry out DV dubbing of a tape recorded in DV format, the tape produced will be in DVCAM format as follows:

- Audio recording mode will be unlock mode.  
(A tape in lock mode may be copied on some video equipment. For details, see the instruction manual supplied with your video equipment.)
- The time code format will be partly maladjusted. (There will be no effect on the recorded picture except in certain case.)

2) If the tape that is to be dubbed is DVCAM formatted tape as explained in 1), the tape produced will be in DVCAM format as follows:

- Audio recording mode will be unlock mode.
- The time code format will be partly maladjusted.

3) Some DV video equipment may be able to playback a DVCAM-formatted tape. However, even if the tape is played back, contents of the playback cannot be guaranteed. Therefore, if an appropriate DVCAM-formatted tape is used for playback, the tape produced will be in DVCAM format and will have a partly maladjusted time code format.

4) The audio recording mode of the edited tape is lock mode. If the tape that is to be dubbed is a DVCAM formatted tape as explained in 1), the audio recording mode of the edited tape is unlock mode.

5) Depending on model of video equipment, you may not be able to edit.

### Note

When you use a tape as explained in 1) to 3) above, you may find limitations regardless of the format of the player and recorder.

## Limitations on editing

When using a tape copied or edited using DV connectors, you will find the following limitations when editing, because of the difference in DVCAM and DV formats.

- Due to the difference of a track pitch, you cannot edit on DV-formatted tapes using DVCAM video equipment.
- You cannot edit DVCAM-formatted tapes recorded in unlock mode using some DVCAM video equipment. In this case, copy the tape again using the audio/video jacks.

## Selecting the recording format

Before recording, it is necessary to select the recording format from either DVCAM or DV SP format.

### Notes

- If recording formats are mixed in one tape, the part where the video images recorded in different formats will be distorted.
- When shooting in DV SP format, the video recorded in back space editing (recording several scenes continuously) may not be smooth. To shoot reliable video, it is recommended that you use a DVCAM cassette and set REC FORMAT to DVCAM (see the following procedure).

- 1 Display the VTR MODE page of the MAINTENANCE menu.

For details on menu operations, see "Basic menu operations" on page 94.

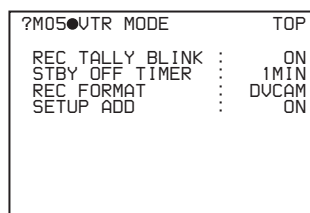

- 2 Press the MENU knob. Then turn the MENU knob to move ➡ to REC FORMAT, and press the MENU knob again.

➡ changes to ●, and ● changes to ?.

- 3 Turn the MENU knob to display the desired recording format (DVCAM or DV SP), then press the MENU knob.

● changes to ➡, ? changes to ●, and the selection is set.

## Adjusting the black balance/white balance

To ensure excellent image quality when using this camcorder, conditions may require that both the black balance and the white balance be adjusted.

If the black balance or white balance adjustment is started, messages that report on the progress and results are displayed on the viewfinder screen when the VF DISP MODE item is set to 2 or 3 on the VF DISP 1 page of the OPERATION menu.

### Note

Black balance and white balance adjustment values that are automatically set by the camcorder and the various settings are stored in the camcorder memory and retained even when the power is turned off.

### To adjust the black balance

The black balance will require adjustment in the following cases.

- When the camcorder is used for the first time
- When the camcorder has not been used for a long time
- When the camcorder is used under conditions in which the surrounding temperature has changed greatly
- When the GAIN switch (L/M/H) values have been changed by using the OPERATION menu

It is not usually necessary to adjust the black balance when using the camcorder after it has been off.

In automatic black balance mode, adjustments are performed in the following order: clamp level, black set, and black balance.

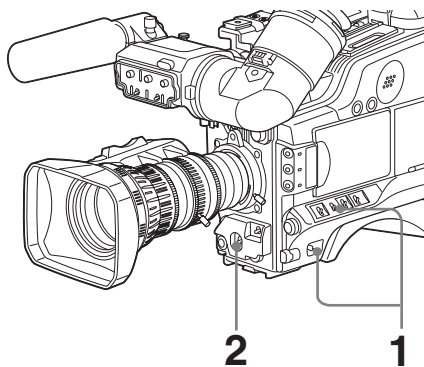

- 1 Power the camcorder on, and set the OUTPUT/DCC switch to CAM.

- 2 Push the AUTO W/B BAL switch to BLACK and release the switch.

The switch returns to the center position, and the adjustment is executed.

During adjustment, the following message is displayed on the viewfinder screen.

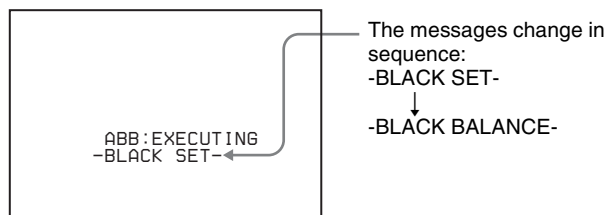

The black balance adjustment ends in a few seconds with the message “ABB: OK” and the adjustment value is automatically stored in memory.

### Notes

- During the black balance adjustment, the iris is automatically closed.
- During the black balance adjustment, the gain selection circuit is automatically activated so you may see flickering on the viewfinder screen, but this is not a malfunction.

### If automatic black balance adjustment cannot be made

If the black balance adjustment cannot be completed normally, an error message will appear for about 3 seconds on the viewfinder screen.

Error message	Meaning
ABB: NG IRIS NOT CLOSED	The lens iris did not close. Check if the lens cable is connected properly. When this error message appears even though the lens iris is closed, the settings of the lens and the camcorder may not match. In this case, consult your lens manufacturer or supplier.
ABB: NG TIME LIMIT	Adjustment could not be completed within the standard number of attempts.
ABB: NG R (or G or B): OVERFLOW	The difference between the reference value and the current value is so great that it exceeds the range.

If any of the above error messages is displayed, retry the black balance adjustment. Keep pushing the AUTO W/B BAL switch to BLACK until “-BLACK SET-” appears after “-BLACK BALANCE-” appears. If the error message occurs repeatedly, contact your Sony service representatives.

## To adjust the white balance

It is necessary to adjust the white balance each time the principal lighting source changes.

- 1 Set the switches and selectors as shown in the figure below.

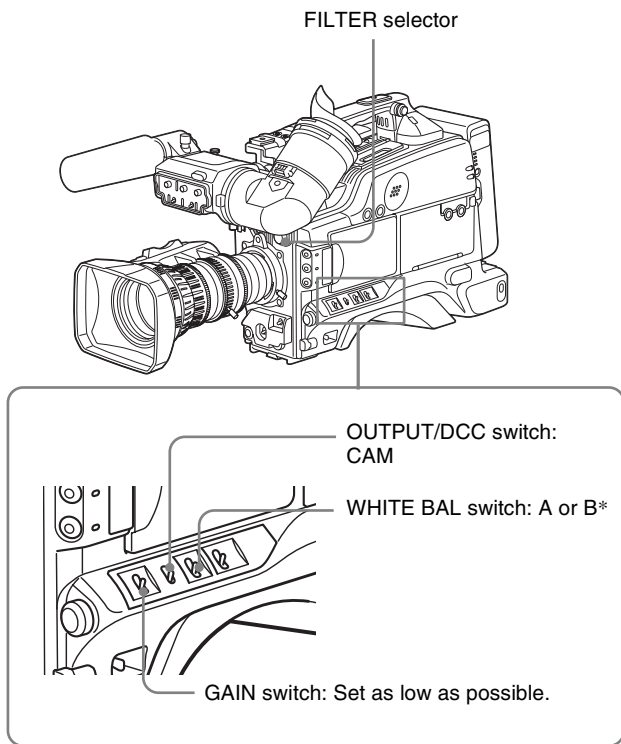

\* White balance setting values are stored in memory B only when the WHITE SWITCH <B> item is set to MEM on the FUNCTION 2 page of the OPERATION menu.

- 2 Set the FILTER selector and the 5600K button to suit the lighting conditions.

FILTER selector setting and CC filter selection are as follows.

Filter setting	Lighting conditions
1 (CLEAR)	Studio halogen lighting (incandescent)
2 (1/4 ND)	Cloudy or rainy outdoor shooting, or to reduce the depth of field
3 (1/16 ND)	Sunlight
4 (1/64 ND)	To reduce the depth of field in sunlight

If the setting of the FILTER selector is changed, a message reporting the setting appears for about 3 seconds in the setting change and adjustment progress message display area of the viewfinder screen (when the display mode is set to 3 on *page 100*).

- 3 Place a white test card under the same lighting conditions as for the subject to be shot and zoom up to it.

Alternatively, any white object such as a cloth or a wall can be used.

The absolute minimum white area is as follows.

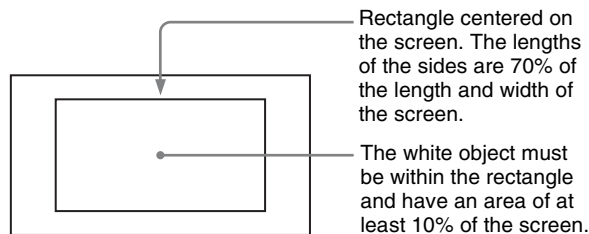

### Note

Make sure there are not bright spots in the rectangle.

- 4 Adjust the lens iris.

Manually adjusted lens: Set the iris to an appropriate setting.

Lens with automatic iris: Set the automatic/manual switch on the lens to automatic.

- 5 Push the AUTO W/B BAL switch to WHITE, and then release the switch.

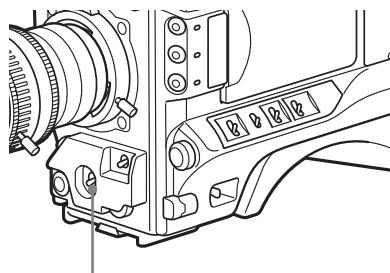

AUTO W/B BAL switch

The switch returns to the center position, and the adjustment is executed.

During adjustment, the message “AWB: EXECUTING” is displayed on the viewfinder screen (when the display mode is set to 2 or 3 (*page 100*)).

The white balance is adjusted in about one second, and the message “ABB: OK” appears. The adjustment setting is automatically stored in the memory (A or B) that was selected in step 1.

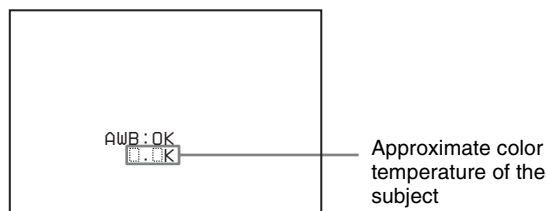

**Note**

If the camera has a zoom lens with an automatic iris, the iris may hunt.\* To prevent this, adjust the iris gain knob (indicated as IG, IS, or S) on the lens.

For details, refer to the lens operation manual.

\* **Hunting:** Repeated brightening and darkening of the image, resulting from repeated response to automatic iris control.

### If the automatic white balance adjustment cannot be made

If the white balance adjustment cannot be completed normally, an error message will appear for about 3 seconds on the viewfinder screen (in display mode 2 or 3).

Error message	Meaning
WHITE: NG LOW LEVEL	The white video level is too low. Either open the lens iris or increase the gain.
WHITE: NG COLOR TEMP HIGH	The color temperature is too high. Select a suitable setting for the 5600K button.
WHITE: NG COLOR TEMP LOW	The color temperature is too low. Select a suitable setting for the 5600K button.
WHITE: NG TIME LIMIT	Adjustment could not be completed within the standard number of attempts. Try to adjust again. If fails a few times, contact your Sony dealer.
WHITE: NG POOR WHITE AREA	The white area could not be checked.
WHITE: NG OVER LEVEL	The white video level is too high. Either stop down the lens iris or change the ND filter.

If any of the above error messages is displayed, retry the white balance adjustment. If the error message occurs repeatedly, contact your Sony service representatives.

### If you have no time to adjust the white balance

Set the WHITE BAL switch to PRST.

The white balance is automatically set as follows, depending on the 5600K button setting.

- 5600K ON (lights on): 5600K
- 5600K OFF (lights off): 3200K

### About the white balance memory

Values stored in memory are held until the white balance is next adjusted.

There are two sets of white balance memories, A and B, and adjustments for each of the filters can be automatically stored in the memory corresponding to the setting (A or B) of the WHITE BAL switch. The camcorder has four built-in filters, so a total of eight (4 × 2) adjustments can be stored. The number of memories allocated to each of A and B can be limited to one by setting the WHT FILTER INH item to ON on the FUNCTION 3 page of the MAINTENANCE menu. In this case, the memory contents are not linked to the filter settings. If the WHITE BAL switch is set to B, and on the FUNCTION 2 page of

the OPERATION menu, the WHITE SWITCH <B> item is set to ATW, the ATW function is activated to automatically adjust the white balance of the picture being shot for varying lighting conditions.

### If a memory error occurs

If the error message “: STORED DATA: NG” flashes on the viewfinder screen when the camcorder is turned on, the white balance memory contents have been lost. Adjust the white balance again. Contact your Sony representative if this message continues to appear even after the white balance have been adjusted again.

## Setting the electronic shutter

This section describes the shutter modes that can be used with the electronic shutter of the camcorder, and describes the procedure for selecting the shutter speed and shutter mode.

### About the shutter modes

The shutter modes that can be used with the electronic shutter and the shutter speeds that can be selected are listed below.

Shutter mode	Shutter speed		Application
	DSR-400/450WS	DSR-400P/450WSP	
Standard	Scan Mode: I 1/100, 1/125, 1/250, 1/500, 1/1000, 1/2000 (sec.)  Scan Mode: PsF <sup>1)</sup> 1/40, 1/60, 1/120, 1/125, 1/250, 1/500, 1/1000, 1/2000 (sec.)  Scan Mode: 24P <sup>2)</sup> 1/32, 1/48, 1/96, 1/125, 1/250, 1/500, 1/1000, 1/2000 (sec.)	Scan Mode: I 1/60, 1/125, 1/250, 1/500, 1/1000, 1/2000 (sec.)  Scan Mode: PsF <sup>1)</sup> 1/33, 1/50, 1/100, 1/125, 1/250, 1/500, 1/1000, 1/2000 (sec.)	For shooting fast-moving subjects with little blurring.

Shutter mode	Shutter speed		Application
ECS (Extended Clear Scan)	DSR-400/ 450WS	Scan Mode: I 60.0 to 6000 Hz Scan Mode: PsF 30.0 to 7000 Hz Scan Mode: 24P <sup>2)</sup> 24.0 to 5000 Hz	For obtaining images with no horizontal bands of noise when shooting subjects such as monitor screens.
	DSR-400P/ 450WSP	Scan Mode: I 50.0 to 6000 Hz Scan Mode: PsF 25.0 to 6000 Hz	
SLS <sup>3)</sup> (Slow Speed Shutter)	DSR-450WS	1 to 8, 16 frames (1/30 to 1/4, 1/2 sec.)	For shooting subjects in low level lighting conditions.
	DSR-450WSP	1 to 8, 16 frames (1/25 to 1/3, 2/3 sec.)	
EVS (Enhanced Vertical definition System)	Shutter speed currently selected in the Standard or ECS mode		Improved vertical resolution. However, the sensitivity and dynamic range are reduced.

1) Only for the DSR-450WS/450WSP

2) Only for the DSR-450WS

3) The SLS mode can only be selected when the CCD scan mode (page 108) is set to I (interlace scan) (DSR-450WS/450WSP only).

### Notes

- Whatever the operating mode of the electronic shutter, the sensitivity of the CCD decreases with increasing shutter speed.
- When the automatic iris is used, the iris opens wider as the shutter speed increases, thus reducing the depth of field.
- Under artificial light, particularly fluorescent or mercury lamps, the light intensity may appear to be constant, but the red, green, and blue intensities are actually changing in synchronization with the frequency of the power supply causing flicker. Using an electronic shutter under such lighting could make the flicker even worse. Color flicker is particularly likely to happen when the power supply frequency is 60 Hz. However, if the power frequency is 50 Hz, setting the shutter speed to 1/100 can reduce this flicker.
- When a bright object is shot in EVS or ECS mode in such a manner that it fills the screen, the upper edge of the picture may have poor quality because of an inherent characteristic of CCDs. Before using EVS or ECS mode, check the shooting conditions.

You can turn on or off the EVS mode on the SW STATUS page of the PAINT menu.

## To select the shutter mode and shutter speed

Use the SHUTTER switch to select a shutter mode or a standard-mode shutter speed. To set the shutter speed in ECS or SLS mode, with the SHUTTER switch set to ON and the ECS or SLS mode selected, use the MENU knob for adjustment.

You can use the SHT ENABLE page of the OPERATION menu to narrow the range of choice in advance, or to select in advance whether or not you use ECS/SLS mode.

## To set the shutter mode and standard mode shutter speed

Once the shutter speed is selected, it is retained even when the camcorder is turned off.

- 1 Set VF DISP MODE to 2 or 3 on the VF DISP 1 page of the OPERATION menu.

For details on menu operations, see “Basic menu operations” on page 94.

?05●VF DISP 1	TOP
VF DISP	ON
VF DISP MODE	1
DISP EXTENDER	ON
DISP WHITE	ON
DISP GAIN	ON
DISP SHUTTER	ON
DISP AUDIO	ON
DISP TAPE	ON
DISP IRIS	ON

- 2 Flick the MENU switch to OFF.

The menu disappears.

- 3 Push the SHUTTER switch from ON to SELECT.

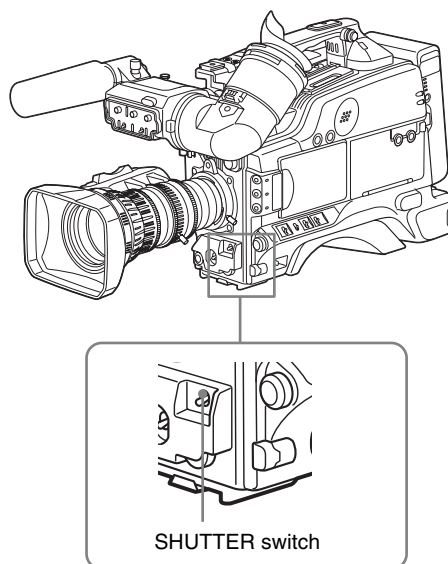

The current shutter setting indication appears for about 3 seconds in the setting change and adjustment progress message display area of the viewfinder screen.

Examples: “: SS: 1/250”, “: SLS: 1/30: 1FRAME”, “: ECS: 60.0 Hz”

- 4** Before the shutter setting indication in step 3 disappears, push the SHUTTER switch down to SELECT again. Repeat this until the desired mode or speed appears.

The settings of mode and speed preselected on the SHT ENABLE page of the OPERATION menu displayed. Note that all modes and all standard-mode speeds listed in the table on page 53 are preselected using the SHT ENABLE page of the OPERATION menu. By factory default, all available shutter modes and shutter speeds are displayed in the sequence shown in the following figure. (You can use the SHT ENABLE page of the OPERATION menu to make a setting so that only the desired (or most frequently used) modes and speeds are displayed.)

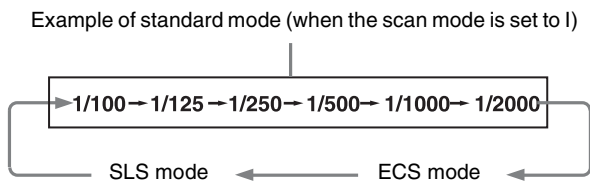

### To set the shutter speed in ECS mode

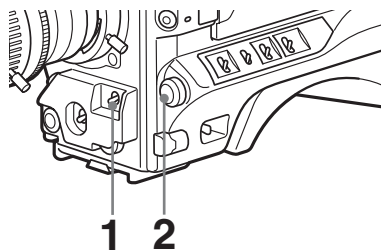

- 1** Follow steps in “To set the shutter mode and standard mode shutter speed” on page 54 to set the shutter speed mode to ECS.

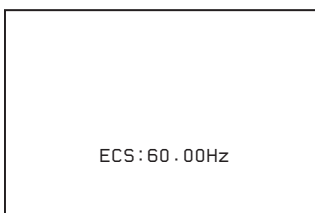

- 2** Turn the MENU knob until the desired frequency appears.

*The selectable frequency range varies depending on the scan mode. See the table on “About the shutter modes” on page 53.*

### When the RM-B150 Remote Control Unit is connected

You can set the shutter speed of ECS with the rotary encoder of the RM-B150.

### To set the shutter speed in SLS mode

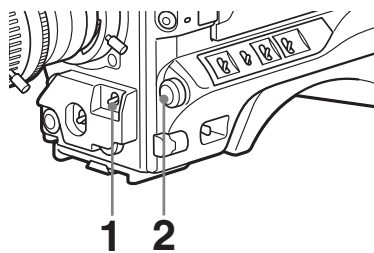

- 1** Follow steps in “To set the shutter mode and standard mode shutter speed” on page 54 to set the shutter speed mode to SLS.

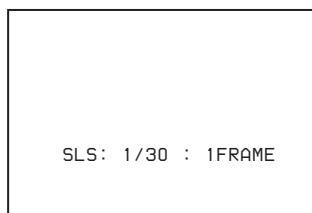

- 2** Turn the MENU knob until the desired number of frames appears.

The number of frames can be set to values in the range 1 to 8, and 16 (1 frame nearly equals to 1/30 second).

### To change the range of shutter mode and speed settings

You can reduce the time required to select the shutter mode and speed by narrowing the choice of settings in advance. This can be done by using the SHT ENABLE page of the OPERATION menu.

#### Note

The settings selected on the SHT ENABLE page of the OPERATION menu become invalid when the RM-B150 Remote Control Unit is connected to the camcorder.

- 1** Display the SHT ENABLE page of the OPERATION menu.

*For details on menu operations, see “Basic menu operations” on page 94.*

? 16●SHT ENABLE	TOP
SHUTTER SLS	ON
SHUTTER ECS	ON
SHUTTER 1/100	ON
SHUTTER 1/125	ON
SHUTTER 1/250	ON
SHUTTER 1/500	ON
SHUTTER 1/1000	ON
SHUTTER 1/2000	ON

- 2** Press the MENU knob. Then turn the MENU knob to move  $\blacktriangleright$  to the shutter mode or shutter speed you want, then press the MENU knob again.

$\blacktriangleright$  changes to ●, and ● changes to ?.

- 3** Turn the MENU knob until ON appears, then press the MENU knob.

● changes to ➔, ? changes to ●, and the selection is set.

To set another mode or speed, return to step **2**.

Note that only the mode and the shutter speeds set to ON can be selected with the SHUTTER switch.

## Adjusting the iris

### To set the automatic iris

The reference value for automatic iris adjustment can be changed to aid the shooting of clear pictures of back-lit subjects, or to prevent blown-out highlights. The reference value for the lens iris can be set within the following range with respect to the standard value.

- 0.5: about 0.5 stop further open
- 1: about 1 stop further open
- -0.5: about 0.5 stop further closed
- -1: about 1 stop further closed

Also you can set the area where light detection occurs.

### To change the reference value

- 1** Set IRIS OVERRIDE to ON on the AUTO IRIS page of the OPERATION menu.

*For details on menu operations, see “Basic menu operations” on page 94.*

? 11●AUTO IRIS	TOP
IRIS OVERRIDE :	ON
IRIS SPEED :	ON
CLIP HIGH LIGHT :	ON
IRIS WINDOW :	1
IRIS WINDOW IND :	OFF
IRIS VAR WIDTH :	1687
IRIS VAR HEIGHT :	6007
IRIS VAR H POS :	0
IRIS VAR V POS :	0

- 2** Flick the MENU switch to OFF.

The AUTO IRIS page disappears from the viewfinder screen.

- 3** Turn the MENU knob to change the reference value as below.

#### Note

When setting the shutter speed while the shutter mode is set to ECS or SLS, the setting of shutter speed takes priority (*page 54*). To change the reference value, make sure the camcorder is not in a process of setting the shutter speed.

#### To open the iris by 0.5 stop

Turn the MENU knob counterclockwise as seen from the front of the camcorder. One bar (□) appears in the upper part to the left of the F number in the iris indication.

#### To open the iris by 1 stop

Turn the MENU knob further counterclockwise as seen from the front of the camcorder. Two bars (□□) appear in the upper part to the left of the F number in the iris indication.



appear in the upper part to the left of the F number in the iris indication.

### To stop down the iris by 0.5 stop

Turn the MENU knob clockwise as seen from the front of the camcorder. One bar (□) appears in the lower part to the left of the F number in the iris indication.

### To stop down the iris by 1 stop

Turn the MENU knob further clockwise as seen from the front of the camcorder. Two bars (□□) appear in the lower part to the left of the F number in the iris indication.

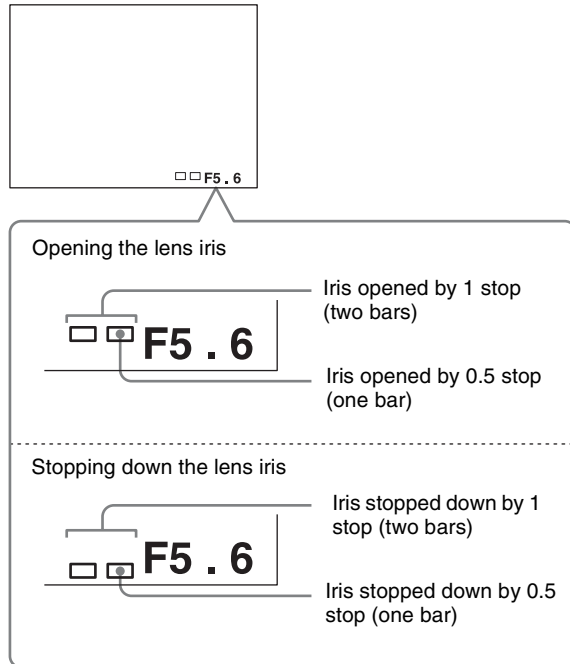

Not turning the MENU knob for a few seconds sets the reference value. The changed reference value is retained until the power of the camcorder is turned off. Even if the reference value is changed, it reverts to the standard value every time the power is turned on.

### When the RM-B150 Remote Control Unit is connected

The IRIS control knob of the RM-B150 can be used for lens iris setting. In this case, the bar display (□) does not appear.

### To select the automatic iris window

- 1 Set IRIS WINDOW IND to ON on the AUTO IRIS page of the OPERATION menu.

*For details on menu operations, see "Basic menu operations" on page 94.*

The currently selected automatic iris window is displayed on the viewfinder.

Set to OFF if the automatic iris window does not need to be always displayed.

- 2 Turn the MENU knob to move ➔ to IRIS WINDOW, and then press the MENU knob.

➔ changes to ● and ● changes to ?.

- 3 Turn the MENU knob to select the desired automatic iris window, and then press the MENU knob.

The shaded parts below indicate the area where light detection occurs.

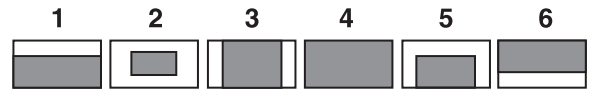

● changes to ➔, ? changes to ●, and the selection is set.

If you select VAR, the following items become effective and you can set the window of the desired size. Set each item to the desired size.

Item	Setting
IRIS VAR WIDTH	Width of the window
IRIS VAR HEIGHT	Height of the window
IRIS VAR H POS	Horizontal position of the window
IRIS VAR V POS	Vertical position of the window

### To counter problems with very bright highlights

If the subject is too bright, the iris may close too much, leaving the overall image dark, or the highlights may be blown out. In such cases, setting the highlight clip function on reduces the luminance range, avoiding problems from the automatic iris correction.

In the AUTO IRIS page of the USER menu, set the CLIP HIGH LIGHT item to ON.

### To adjust the iris sensitivity

When you use the VCL-917BY lens, you usually need not adjust the iris sensitivity because lenses are equipped with iris sensitivity adjustment function.

In auto iris mode, if hunting or response delay happens, adjust the iris sensitivity using the iris sensitivity trimmer.

Iris sensitivity trimmer (S or IRIS GAIN is indicated.)

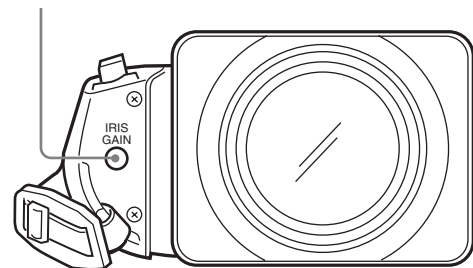

You can see the iris sensitivity trimmer when removing the gum cap on the front of the lens driving unit. Use a mini-screwdriver to turn the trimmer. If you turn it clockwise, the sensitivity increases, and if you turn it counterclockwise, the sensitivity decreases. It is recommended that you confirm the iris sensitivity after replacing the lens.

For more information, refer to the operating instructions for the lens (or consult the lens maker).

## Adjusting the audio level

Setting the AUDIO SELECT (CH-1/CH-2) switches to AUTO automatically adjusts the input levels of the audio signal to be recorded in audio channels 1 and 2.

### To manually adjust the levels of the audio inputs from the AUDIO IN CH-1/CH-2 connectors

Proceed as follows to adjust the levels of the audio inputs from the AUDIO IN CH-1/CH-2 connectors, which are to be recorded in audio channels 1 and 2.

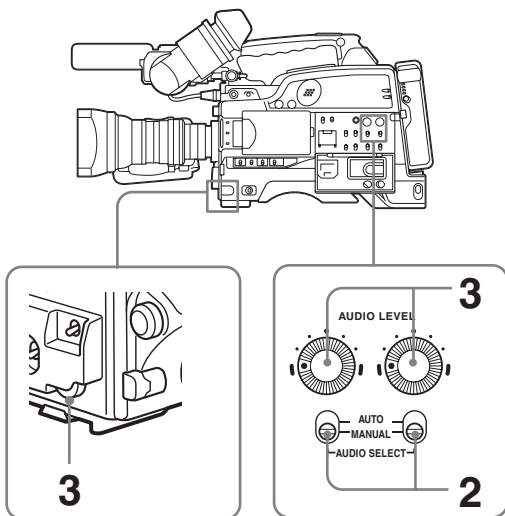

- 1 Select the audio channel that you want to record in.  
*For details, see “Selection of the recording audio input” on page 38.*
- 2 Set the AUDIO SELECT (CH-1/CH-2) switch(es) corresponding to the audio channel(s) selected in step 1 to MANUAL.
- 3 With the AUDIO LEVEL control on the side of the camcorder and the AUDIO LEVEL control on the front of the camcorder, adjust so that the audio level meter shows up to  $-20$  dB for a normal input volume.

The input level value of the audio channel 1 is the value of the AUDIO LEVEL CH-1 control on the side multiplied by the value of the AUDIO LEVEL control on the front.

The input level value of the audio channel 2 is the value of the AUDIO LEVEL CH-2 control.

When the top bar (0 dB) turns on, the audio level is too high. There is no problem if the second bar from the top turns on.

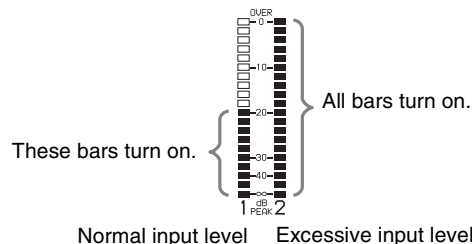

### To adjust manually the level of audio channel 1 without using the AUDIO LEVEL control on the front of the camcorder

Set F AUDIO VOL to DISABLE on the AUDIO page of the MAINTENANCE menu.

The setting of the AUDIO LEVEL control on the front of the camcorder is disabled.

## Setting the time data

### To set the time code

The time code setting range is from 00:00:00:00 to 23:59:59:29 (DSR-400/450WS) or 23:59:59:24 (DSR-400P/450WSP) (hours: minutes: seconds: frames).

#### Note

When the scan mode is 24P, see “Setting the CCD scan mode (DSR-450WS/450WSP only)” on page 108 (DSR-450WS only).

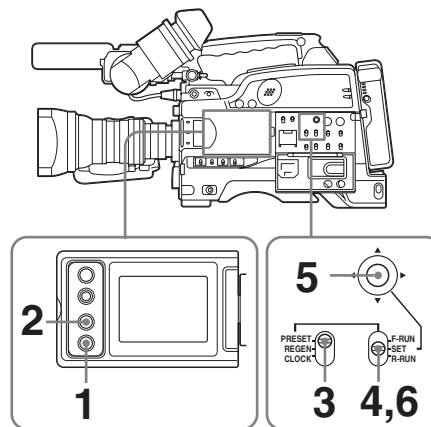

- 1 Press the DISP SEL button of the LCD monitor to display the STATUS screen.

- 2 Press the DISPLAY button of the LCD monitor to display TC on the counter display section.
- 3 Set the PRESET/REGEN/CLOCK switch to PRESET.
- 4 Set the F-RUN/SET/R-RUN switch to SET.  
The first (left-most) digit of time code flashes.
- 5 Use the arrow key to set the time code value including the last (right-most) digit of the time code.  
  
To reset the time code value to 00:00:00:00, press the RESET button of the LCD monitor.
- 6 Set the F-RUN/SET/R-RUN switch to the desired operating mode for the time code generator.

**F-RUN:** Free run. The time code generator keeps running.

**R-RUN:** Recording run. The time code generator runs only while recording.

### To set the DF (drop frame)/NDF (non-drop frame) mode

You can select the drop frame (DF) mode or non-drop frame (NDF) mode on the FUNCTION 1 page of the OPERATION menu.

#### Note

When the scan mode is 24P, see “Setting the CCD scan mode (DSR-450WS/450WSP only)” on page 108 (DSR-450WS only).

### To make the time code consecutive

When the F-RUN/SET/R-RUN switch is set to R-RUN, recording a number of scenes on the tape normally produces consecutive time code. However, once you remove the cassette and record on another cassette, the time code will no longer be contiguous even when you use again the original cassette for recording.

In this case, to make the time code consecutive, proceed as follows.

- 1 Set the PRESET/REGEN/CLOCK switch to REGEN.
- 2 Use the EDIT SEARCH +FWD/–REV button to select the point where the recording should be start again.

This reads the previous recording and synchronizes the internal time code generator, thus allowing the new time code to be recorded consecutively.

### To save the actual time in the time code

Setting the PRESET/REGEN/CLOCK switch to CLOCK saves the actual time in the time code. When it is necessary to set the actual time, use the TIME/DATE page of the DIAGNOSIS menu.

For details, see “Setting the date/time of the internal clock” on page 106.

#### Note

When the scan mode is 24P, see “Setting the CCD scan mode (DSR-450WS/450WSP only)” on page 108 (DSR-450WS only).

### To set the user bits

By setting the user bits (up to 8 hexadecimal digits), you can record user information such as the date, time, or scene number on the time code track.

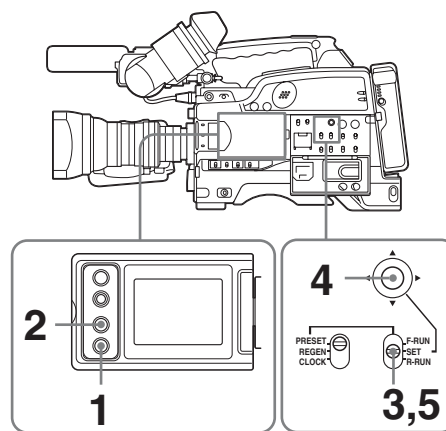

- 1 Press the DISP SEL button of the LCD monitor to display the STATUS screen.
- 2 Press the DISPLAY button on the LCD monitor to display U-BIT in the counter display section.
- 3 Set the F-RUN/SET/R-RUN switch to SET.  
The first (left-most) digit flashes.
- 4 Use the arrow key to set the time code value including the last (right-most) digit of time code.  
  
Hexadecimal digits A to F are displayed as A to F in capital letters.  
To reset the user bit data to 00 00 00 00, press the RESET button of the LCD monitor.
- 5 Set the F-RUN/SET/R-RUN switch to the desired operating mode for the time code generator.  
  
**F-RUN:** Free run. The time code generator keeps running.  
**R-RUN:** Recording run. The time code generator runs only while recording.

### To synchronize the time code

You can synchronize the internal time code generator of this camcorder with an external generator for the regeneration of an external time code. You can also

synchronize the time code generators of other camcorders/ VTRs with the internal generator of this camcorder.

### Connections for time code synchronization

Connect both the reference video signal and the external time code as illustrated below.

#### Example 1: Synchronizing with an external time code

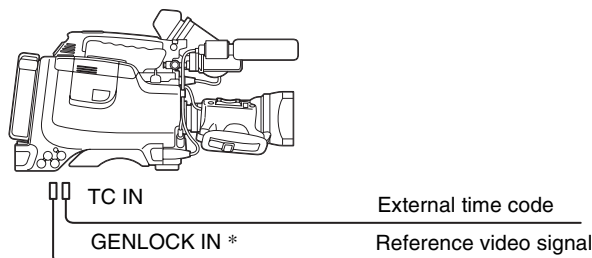

\* Set GENLOCK to ON on the GENLOCK page of the MAINTENANCE menu, if GENLOCK is set to OFF.

#### Example 2: Interconnecting a number of camcorders and using one of them as the reference camcorder for time code synchronization

##### Notes

- In the following configuration, wait until the reference camcorder becomes stable (a state where a normal picture appears on the viewfinder or the LCD monitor), and then connect the other camcorders.
- When the scan mode is 24P, see “Setting the CCD scan mode (DSR-450WS/450WSP only)” on page 108 (DSR-450WS only).

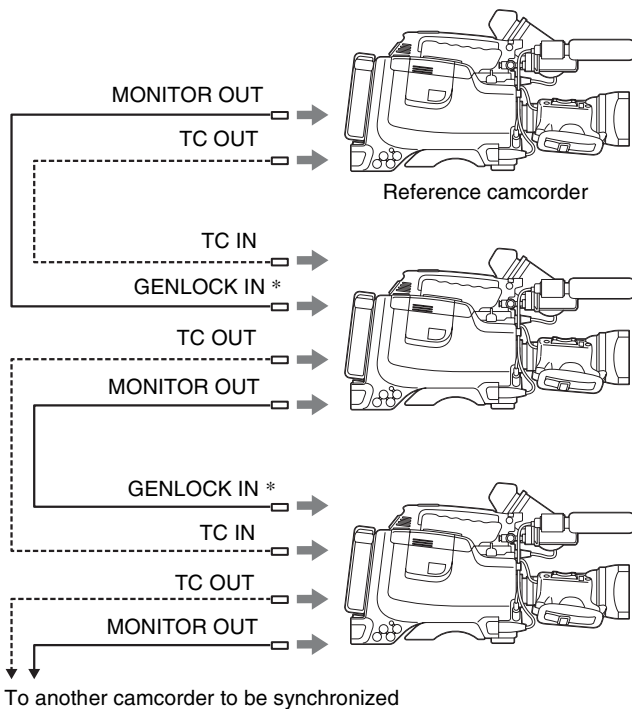

\* Set GENLOCK to ON on the GENLOCK page of the MAINTENANCE menu, if GENLOCK is set to OFF.

### To synchronize the time code

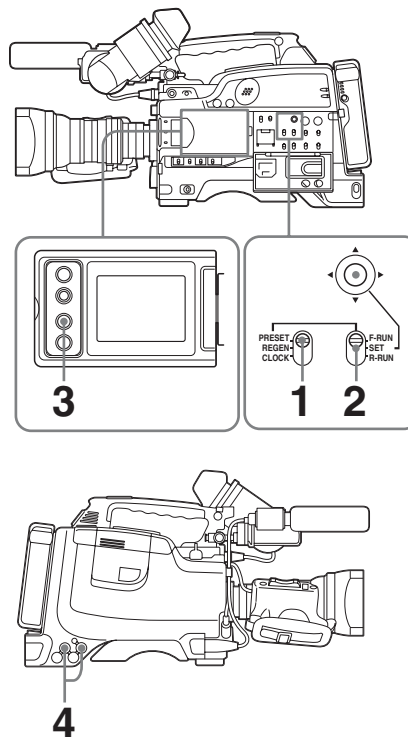

- 1 Set the PRESET/REGEN/CLOCK switch to PRESET.
- 2 Set the F-RUN/SET/R-RUN switch to F-RUN.
- 3 Press the DISPLAY button of the LCD monitor to display TC on the counter display section.
- 4 Supply a time code signal and a reference video signal complying with the SMPTE standard and in proper phase relationship, to the TC IN connector and to the GENLOCK IN connector, respectively.

This operation synchronizes the internal time code generator with the external time code. After about 10 seconds, you can disconnect the external time code without losing the synchronization. However, there will be noise on the recorded image if you connect or disconnect the time code signal during recording.

##### Notes

- When you finish the above procedure, the internal time code is immediately synchronized with the external time code and the counter display will show the value of the external time code. However, wait for a few seconds until the sync generator stabilizes before recording.
- If the frequency of the reference video signal is not the same as the frame frequency of the camcorder, the camera cannot be correctly genlocked. In such a case, the internal time code is not correctly synchronized with the external time code.

- When the internal time code generator is set to F-RUN mode, the precision of the synchronization may be reduced if you turn the POWER switch off and on or keep the camcorder turned off for a long time.
- When the GENLOCK item is set to OFF on the GENLOCK page of the MAINTENANCE menu, the time code cannot be synchronized with the reference video signal. In this case, set the GENLOCK item to ON.

### About user bit settings during time code synchronization

When the time code is synchronized, only the time data is synchronized with the external time code value. Therefore, the user bits can have their own settings for each camcorder.

### To release the time code synchronization

First disconnect the external time code, then set the F-RUN/SET/R-RUN switch to R-RUN.

### To change the power supply from the battery pack to an external power supply during time code synchronization

To maintain a continuous power supply, connect the external power supply to the DC IN connector before removing the battery pack. You may lose time code synchronization if you remove the battery pack first.

### Camera synchronization during time code synchronization

During time code synchronization, the camera is genlocked to the reference video signal input from the GENLOCK IN connector.

## Setting for special shooting cases

Depending on the shooting conditions, set the camcorder appropriately referring below.

Shooting conditions	Setting and effect
The subject is completely still (Example: When shooting documents, drawings, etc.).	<b>Setting:</b> Set the EVS (Enhanced Vertical definition System) function to ON on the SW STATUS page of the PAINT menu. Enabling the EVS function tends to increase the occurrence of aliasing problems (moiré patterns). Therefore, normally leave the function disabled. <b>Effect:</b> This enhances the vertical resolution.
When adjusting for skin detail or tone (Example: When shooting to hide skin details)	<b>Setting:</b> See "To correct skin detail" on page 61. <b>Effect:</b> This adjusts the skin detail or tone to a designated active area.

Shooting conditions	Setting and effect
The 3200K preset white balance makes the picture reddish.	<b>Setting:</b> Change the setting of the preset white balance on the PRESET WHT page of the MAINTENANCE menu. <b>Effect:</b> This prevents the picture from reddening.

### To correct skin detail

You can specify a color other than a skin tone to adjust the color.

- 1 Set SKIN AREA IND to ON on the SKIN DETAIL page of the PAINT menu.  
*For details on menu operations, see "Basic menu operations" on page 94.*
- 2 Set SKIN DETECT on the SKIN DETAIL page of the PAINT menu.  
This causes the area detect cursor to be shown in the viewfinder.
- 3 Place the area detect cursor on the target, then execute SKIN DETECT.  
This designates the correction area, which is indicated by a zebra pattern.
- 4 Change the value of SKIN DTL WIDTH (0 to 359) on the SKIN DETAIL page so that the zebra pattern may be displayed in the target area.  
Set the correction level beforehand on the SKIN DETAIL LVL item on the SKIN DETAIL page.
- 5 When the setting is finished, set SKIN AREA IND to OFF on the SKIN DETAIL page.

# Back Space Editing

This section describes the steps for recording several scenes continuously.

- 1 Follow steps in “Basic Procedure for Shooting” on page 47 to begin recording.

To continue the time code that has been recorded on the tape, set the F-RUN/SET/R-RUN switch to R-RUN.

For details of time codes, see “Setting the time data” on page 58.

- 2 When you have finished recording a scene, press the REC button on the camcorder or the VTR button on the lens.

This pauses the recording operation.

## Note

**Do not do any of the following before the next scene is shot as it will interrupt the recording (the recording will not be continuous).**

- Remove the cassette.
- Transport the tape (play, rewind, fast forward).
- Replace the battery when the camcorder is powered.

- 3 When you are ready to shoot the next scene, again press the REC button on the camcorder or the VTR button on the lens.

This restarts the recording operation.

- 4 Repeat steps 2 and 3 for each scene to be shot.

To	Procedure
Restart an interrupted recording (see step 2 above)	See next section “Starting back space editing at any tape position” on page 62.
Check the recorded contents	See “Checking the recorded contents immediately after shooting — Recording Review” on page 66.
Stop recording	Press the REC button on the camcorder or the VTR button on the lens, then press the STOP button.

## If there is a long period before shooting the next scene

Once put the camcorder into recording pause mode, it waits a certain (user-definable) period of time and then automatically switches to standby-off mode. When the

camcorder is in standby-off mode, it takes time for the recording to start after pressing the REC button.

You can set the time out value for automatic switching to standby-off mode from 1 minute, 3 minutes, or 5 minutes, on the VTR MODE page of the MAINTENANCE menu (page 85).

## Starting back space editing at any tape position

This section describes the steps for inserting a new scene at any desired position on the tape.

The following steps can also be used to restart recording after an interruption has occurred.

- 1 Insert the cassette containing the previous recording.
- 2 Perform steps 2 to 11 in “Basic Procedure for Shooting” on page 47.

To continue from the last time code of the previous recording, set the PRESET/REGEN/CLOCK switch to REGEN.

For details about time codes, see “Setting the time data” on page 58.

- 3 Press the PLAY button.

The recorded contents are displayed on the viewfinder screen.

Operation at playback	Procedure
Fast forward the tape	Press the F FWD button.
Rewind the tape	Press the REW button.

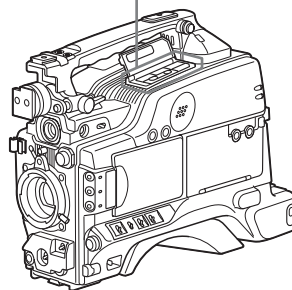
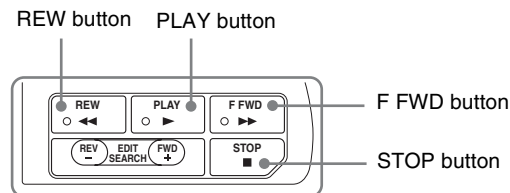

- 4 Press the STOP button when the tape reaches the position where you want to start the new recording (see the figure in step 3).

This stops playback.

- 5 Press the RET button on the lens.

This rewinds the tape slightly and runs it until the continue point, then sets the camcorder to recording pause state.

- 6 Press the REC button on the camcorder or the VTR button on the lens.

This starts recording.

*To carry out back space editing frame by frame, specify the continue position using the edit search function. For details, see the next section “Using the edit search function while back space editing”.*

### Notes

- When the scan mode is 24P, see “Setting the CCD scan mode (DSR-450WS/450WSP only)” on page 108 (DSR-450WS).
- If you set the POWER switch to off during recording or when recording is paused, the camcorder automatically goes through its shut-down sequence, then powers off. When you next set the POWER switch to on, the camcorder automatically finds the point at which recording ended, and sets itself up so that you can carry in with continuous recording. Note that this operation takes several seconds: do not set the POWER switch to off or replace the battery during this interval, as the automatic recording continuity will be lost. Note also that the recording continuity is lost in the following cases.
  - If the POWER switch is set to on and off repeatedly.
  - If the camcorder is left powered off for several hours.
  - If the camcorder is subject to severe vibration while powered off.
  - If for any other reason the automatic recording continuity function is unable to operate correctly.
  - If the lithium battery (CR2032) is exhausted, or if no lithium battery has been fitted.
  - If the recording format is changed.

## Using the edit search function while back space editing

You can use the edit search function to find the desired tape location when continuing to record from any other location on the tape. Press and hold one of the EDIT SEARCH +FWD/-REV buttons to activate the search playback function for as long as you hold down it.

- 1 Insert the cassette containing the previous recording.
- 2 Perform steps 2 to 11 in “Basic Procedure for Shooting” on page 47.
- 3 Press and hold either of the +FWD or -REV button of the EDIT SEARCH +FWD/-REV buttons.

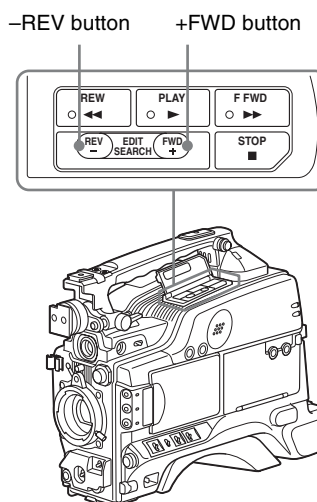

The tape is moved in reverse or forward search mode for as long as you hold down the button, and the image is shown in the viewfinder.

### Note

Do not shut off the power while using the edit search function. The continue point may be lost.

- 4 Release the +FWD or -REV button when you find the tape location where you want to continue shooting. Recording is paused.
- 5 Press the REC button on the camcorder to the VTR button on the lens. Recording starts.

### Note

When the scan mode is 24P, see “Setting the CCD scan mode (DSR-450WS/450WSP only)” on page 108 (DSR-450WS only).

# Time-Lapse Video (Interval Rec)

Interval Rec mode is effective for shooting objects that move very slowly. As shown in the following figure, you need to set the recording time for one recording session (REC TIME) and the total time consisting of one recording session and the following interval (INTERVAL TIME).

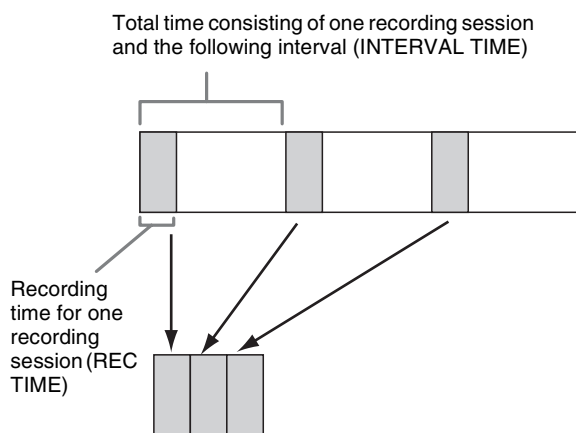

A pre-lighting function is available. This function automatically turns on the light before recording starts, which allows you to record pictures under stable light and color temperature conditions.

## Making settings before shooting

To record in Interval Rec mode, you need to set the related items beforehand as follows.

- 1 Set INTERVAL REC to ON on the FUNCTION 1 page of the OPERATION menu.

For details on menu operations, see “Basic menu operations” on page 94.

? 03●FUNCTION1	TOP
ASSIGN SW <1>	: ATW
ASSIGN SW <2>	: OFF
ASSIGN SW <3>	: OFF
ASSIGN SW <4>	: OFF
DF/NDF	: DF
INTERVAL REC	: ON
REC TIME	: 0.5S
INTERVAL TIME	: 30S
PRE-LIGHTING	: OFF

The camcorder is in Interval Rec mode. The TALLY indicator (green) in the viewfinder flashes (one flash/second) while the camcorder is in this mode.

- 2 Set INTERVAL TIME (total time consisting of one recording session and the following interval) on the FUNCTION 1 page of the OPERATION menu.

You can select either 30S, 1M, 5M, 10M, 30M, or 1H. Here S means seconds (30S is 30 seconds), M means minutes (5M is 5 minutes), and H means hours (1H is one hour).

- 3 Set REC TIME (recording time for one recording session) on the FUNCTION 1 page of the OPERATION menu.

You can select either 0.5S, 1.0S, 1.5S, 2.0S, 5S, 10S, 30S, 1M, 5M, or 10M.

Here S means seconds (5S is 5 seconds) and M means minutes (1M is one minute).

- 4 To turn on the light automatically before starting to record, set PRE-LIGHTING (time to turn on the light before starting to record) on the FUNCTION 1 page of the OPERATION menu.

You can select either OFF, 2S, 5S, or 10S.

### Notes

- Set the LIGHT switch on the camcorder to AUTO to turn on the light before recording. The light switch must also be set to ON. With these settings, the light turns on and off automatically. However, the light remains on continuously if the off time is less than 5 seconds.
- When the LIGHT switch is set to MAN and the light switch is set to ON, the light remains on continuously.

To end the menu operation, flick the MENU switch to OFF. The menu disappears from the screen and the message “INTERVAL” flashes along the bottom of the screen.

You can check the setting of Interval Rec in the VTR STATUS window (page 103).

### Note

The camcorder exits Interval Rec mode whenever it is powered off. However, the settings of INTERVAL TIME, REC TIME, etc. are maintained. You do not need to set them again the next time you use Interval Rec mode.

## Shooting and recording in Interval Rec mode

- 1 After performing the basic procedures for shooting and recording, following the instructions in “Making settings before shooting” on page 64, secure the camcorder so that it will not move.
- 2 Press the REC button on the camcorder or the VTR button on the lens.



The camcorder starts recording in Interval Rec mode. When you use the pre-lighting function, recording starts after the light is switched on. While recording in Interval Rec mode, the TALLY indicator (green) in the viewfinder flashes (4 flashes/second) and the message "INTERVAL" appears on the viewfinder screen. While recording, the REC indicator in the viewfinder lights.

### To interrupt interval recording

Press the REC button on the camcorder or the VTR button on the lens. The camcorder operates as explained below.

#### When the button is pressed during interval recording

Recording in Interval Rec mode stops. Press the REC or VTR button again to start recording in Interval Rec mode again.

#### When the button is pressed during a pause of interval recording

Recording in Interval Rec mode stops, and normal recording starts. Press the REC or VTR button again to interrupt recording. Press the REC or VTR button once again to start recording in Interval Rec mode.

### To end auto interval recording

You can exit Interval Rec mode by setting the POWER switch to OFF or setting INTERVAL REC to OFF on the FUNCTION 1 page of the OPERATION menu.

## Notes on Auto Interval Rec mode

### Audio

Audio fade-in/fade-out functions are not carried out in Interval Rec mode.

### Playback control buttons

While recording in Interval Rec mode, you cannot use the playback control buttons (EJECT, REW, F FWD, PLAY, and STOP). To use these buttons, stop recording by pressing the REC button on the camcorder or the VTR button on the lens.

### Menu operation

While recording in Interval Rec mode, you cannot change the settings of INTERVAL TIME and REC TIME. To change the settings, stop recording by pressing the REC button on the camcorder or the VTR button on the lens.

# Recording Analog Composite Signals (with a CBK-SC01 Installed- DSR-450WS/450WSP only)

Installing a CBK-SC01 Composite Input Board in the camcorder enables you to record analog composite signals from external equipment connected to the GENLOCK IN connector.

- 1 Set REC VIDEO SOURCE to EXT on the SOURCE SEL page of the OPERATION menu.

*For details on menu operations, see "Basic menu operations" on page 94.*

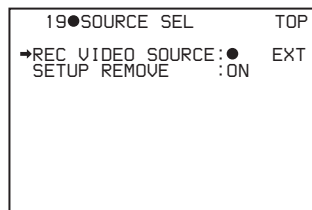

- 2 Input analog composite signals to the GENLOCK IN connector of the camcorder.

These signals are displayed on the viewfinder and the LCD monitor, and can be recorded on the tape.

### Note

Even when the GENLOCK item is set to OFF on the GENLOCK page of the MAINTENANCE menu, the camcorder is automatically synchronized with the external reference video signal when the external video signal is input to the GENLOCK IN connector in EXT mode. When the setting is switched to CAM mode, or when no signals are input even in EXT mode, the camcorder is reset to the original setting.

### To use setup remove (DSR-450WS only)

Setup remove is a function that removes a setup that has been added to a video signal when recording. The factory setting of setup remove is ON.

In order to set the setup remove function off, select OFF in SETUP REMOVE on the SOURCE SEL page of the OPERATION menu.

## Playing and Checking Recorded Contents

By pressing the PLAY button, you can review any length of recording on the viewfinder screen in black and white or in color on the LCD monitor. There are two other ways to review the recording.

- **Recording review:** You can view the last two to ten seconds of the recording on the viewfinder screen in black and white or in color on the LCD monitor.
- **Playback in external color video monitor:** You can see the recording in color on a color video monitor without the need for any external adaptor.

*For details about the switches and controls used to select the audio output signal and to adjust the audio level, see “Location and Function of Parts” on page 10.*

### Checking the recorded contents immediately after shooting — Recording Review

With recording paused, press the RET button on the lens. The tape is automatically rewound over the last approximately 2 seconds of the recording (approximately 10 seconds maximum if you press and hold the RET button), and then this last part of the recording is shown in the viewfinder and on the LCD monitor. Use this function to check whether recording went correctly.

By assigning the LENS RET function to the ASSIGN switch, you can use the switch in the same way as the lens RET button.

*For details, see “Assigning functions to ASSIGN switches” on page 107.*

#### Notes

- During recording review, do not set the POWER switch to off. The camcorder may not be able to find the continue point.
- You cannot start recording until the recording review has finished.

## Checking the recording on the color video monitor

Connect a color video monitor to the MONITOR OUT connector or the VIDEO OUT connector of the camcorder. By pressing the PLAY button, you can view the recorded picture.

*For details about how to connect a monitor, see “Connecting a Monitor” on page 41.*

#### Note

For the DSR-450WS/450WSP, only the picture displayed through the camera is output to the CBK-SD01 SDI Output Board. Playback pictures cannot be output even during playback.

### To use setup add (DSR-400/450WS only)

Setup add is a function that adds a setup to the playback video signal. To activate this function, set SETUP ADD to ON on the VTR MODE page of the MAINTENANCE menu.

#### Notes

- The video image that connects the DVCAM format and DV format is distorted during playback.
- The camcorder can play video and audio that is recorded in DVCAM format or DV format (in SP mode).
- If two or more audio sampling frequencies are mixed on one tape, the part where the video images are recorded in different frequencies will be distorted.

## Menu Organization and Operation

The following shows the organization of menus in this camcorder.

*For details about USER MENU CUSTOMIZE, see “Editing the USER menu” on page 96.*

*The USER menu consisting of items and pages registered at the factory is used. The number in parenthesis is the page number that setting is displayed on.*

Menu selection	1st hierarchy	2nd hierarchy	3rd hierarchy
TOP MENU	USER	Page 1	<ul style="list-style-type: none"> <li>— IRIS OVERRIDE (79)</li> <li>— DETAIL LEVEL (83)</li> <li>— MASTER BLACK (81)</li> <li>— BLACK GAMMA (82)</li> <li>— MASTER BLK GAMMA (82)</li> <li>— COLOR TEMP &lt;P&gt; (87)</li> </ul>
		Page 2	<ul style="list-style-type: none"> <li>— SKIN DETAIL ALL (83)</li> <li>— SKIN DETECT (83)</li> <li>— SKIN AREA IND (83)</li> <li>— SKIN DTL SELECT (83)</li> <li>— SKIN DETAIL (83)</li> <li>— SKIN DETAIL LVL (83)</li> </ul>
		Page 3	<ul style="list-style-type: none"> <li><input type="checkbox"/> SCN 1 (85)</li> <li><input type="checkbox"/> SCN 2 (85)</li> <li><input type="checkbox"/> SCN 3 (85)</li> <li><input type="checkbox"/> SCN 4 (85)</li> <li><input type="checkbox"/> SCN 5 (85)</li> <li><input type="checkbox"/> STANDARD (85)</li> </ul>
		Page 4	<ul style="list-style-type: none"> <li>— REC FORMAT (87)</li> <li>— AU MODE (87)</li> <li>— 16:9/4:3 SELECT <sup>1)</sup> (80)</li> <li>— SCAN MODE <sup>1)</sup> (80)</li> <li>— REC VIDEO SOURCE <sup>2)</sup> (80)</li> <li>— REAR BNC OUT SEL <sup>3)</sup> (76)</li> </ul>
		Page 5	<ul style="list-style-type: none"> <li>— GL H PHASE (89)</li> <li>— GL SC PHASE (89)</li> <li>— GL SC 0/180 SEL (89)</li> </ul>
		Page 6	<ul style="list-style-type: none"> <li>— MARKER (78)</li> <li>— CENTER (78)</li> <li>— SAFETY ZONE (78)</li> </ul>
		Page 7	<ul style="list-style-type: none"> <li>— ASSIGN SW &lt;1&gt; (77)</li> <li>— ASSIGN SW &lt;2&gt; (77)</li> <li>— ASSIGN SW &lt;3&gt; (77)</li> <li>— ASSIGN SW &lt;4&gt; (77)</li> </ul>
	(Continued)	(Continued)	

1) Only for the DSR-450WS/450WSP

2) Only when a CBK-SC01 Composite Input Board is installed in the DSR-450WS/450WSP

3) Only when a CBK-SD01 SDI Output Board is installed in the DSR-450WS/450WSP

Menu selection	1st hierarchy	2nd hierarchy	3rd hierarchy
		Page 8	CLOCK ADJUST (92) HOUR (92) MIN (92) SEC (92) YEAR (92) MONTH (92) DAY (92)
	USER MENU CUSTOMIZE		
	ALL		
	• OPERATION	OUTPUT	LCD BRIGHT <L> LCD BRIGHT <H> LCD COLOR REAR BNC OUT SEL <sup>2)</sup>
		MONITOR OUT	MONI OUT VF DISP MONI OUT MENU MONI OUT TC MONI OUT MARKER MONI OUT ZEBRA
		FUNCTION 1	ASSIGN SW <1> ASSIGN SW <2> ASSIGN SW <3> ASSIGN SW <4> DF/NDF <sup>3)</sup> INTERVAL REC REC TIME INTERVAL TIME PRE-LIGHTING
		FUNCTION 2	D5600 WIDE AWB WHITE SWITCH <B> SHOCKLESS WHITE ATW SPEED LOW LIGHT LOW LIGHT LEVEL VF BATT WARNING
		VF DISP 1	VF DISP VF DISP MODE DISP EXTENDER DISP FILTER DISP WHITE DISP GAIN DISP SHUTTER DISP AUDIO DISP TAPE DISP IRIS
		VF DISP 2	DISP COLOR TEMP DISP BATT REMAIN DISP DC IN DISP 16:9/4:3 ID <sup>1)</sup> DISP VTR STATUS DISP VTR TRIGGER DISP TIME CODE DISP REC FORMAT
		MARKER 1	MARKER CENTER SAFETY ZONE SAFETY AREA ASPECT <sup>1)</sup> ASPECT SELECT <sup>1)</sup> ASPECT MASK(4:3) <sup>1)</sup> ASPECT MASK LVL <sup>1)</sup> 100%MARKER
	(Continued)	(Continued)	

1) Only for the DSR-450WS/450WSP

2) Only when a CBK-SD01 SDI Output Board is installed in the DSR-450WS/450WSP

3) Only for the DSR-400/450WS

Menu selection	1st hierarchy	2nd hierarchy	3rd hierarchy
		MARKER 2	<ul style="list-style-type: none"> <li>— USER BOX</li> <li>— USER BOX WIDTH</li> <li>— USER BOX HEIGHT</li> <li>— USER BOX H POS</li> <li>— USER BOX V POS</li> <li>— CENTER H POS</li> <li>— CENTER V POS</li> </ul>
		GAIN SW	<ul style="list-style-type: none"> <li>— GAIN LOW</li> <li>— GAIN MID</li> <li>— GAIN HIGH</li> <li>— GAIN TURBO</li> <li>— TURBO SW IND</li> </ul>
		VF SETTING	<ul style="list-style-type: none"> <li>— ZEBRA</li> <li>— ZEBRA SELECT</li> <li>— ZEBRA1 DET LEVEL</li> <li>— ZEBRA1 APT LEVEL</li> <li>— ZEBRA2 DET LEVEL</li> <li>— VF DETAIL LEVEL</li> <li>— VF ASPECT <sup>1)</sup></li> </ul>
		AUTO IRIS	<ul style="list-style-type: none"> <li>— IRIS OVERRIDE</li> <li>— IRIS SPEED</li> <li>— CLIP HIGH LIGHT</li> <li>— IRIS WINDOW</li> <li>— IRIS WINDOW IND</li> <li>— IRIS VAR WIDTH</li> <li>— IRIS VAR HEIGHT</li> <li>— IRIS VAR H POS</li> <li>— IRIS VAR V POS</li> </ul>
		SHOT ID	<ul style="list-style-type: none"> <li>— ID-1</li> <li>— ID-2</li> <li>— ID-3</li> <li>— ID-4</li> </ul>
		SHOT DISP	<ul style="list-style-type: none"> <li>— SHOT DATE</li> <li>— SHOT TIME</li> <li>— SHOT MODEL NAME</li> <li>— SHOT SERIAL NO</li> <li>— SHOT ID SEL</li> <li>— SHOT 16:9 ID <sup>1)</sup></li> <li>— SHOT BLINK CHARA</li> </ul>
		SET STATUS	<ul style="list-style-type: none"> <li>— STATUS CAMERA</li> <li>— STATUS VTR</li> </ul>
		OFFSET WHT	<ul style="list-style-type: none"> <li>— OFFSET WHITE &lt;A&gt;</li> <li>— WARM-COOL &lt;A&gt;</li> <li>— COLOR FINE &lt;A&gt;</li> <li>— OFFSET WHITE &lt;B&gt;</li> <li>— WARM-COOL &lt;B&gt;</li> <li>— COLOR FINE &lt;B&gt;</li> </ul>
		SHT ENABLE	<ul style="list-style-type: none"> <li>— SHUTTER SLS <sup>1)</sup></li> <li>— SHUTTER ECS</li> <li>— SHUTTER 1/32 <sup>2)</sup></li> <li>— SHUTTER 1/33 <sup>3)</sup></li> <li>— SHUTTER 1/40 <sup>4)</sup></li> <li>— SHUTTER 1/48 <sup>2)</sup></li> <li>— SHUTTER 1/50 <sup>3)</sup></li> <li>— SHUTTER 1/60 <sup>5)</sup></li> <li>— SHUTTER 1/96 <sup>2)</sup></li> <li>— SHUTTER 1/100 <sup>6)</sup></li> <li>— SHUTTER 1/120 <sup>4)</sup></li> <li>— SHUTTER 1/125</li> <li>— SHUTTER 1/250</li> <li>— SHUTTER 1/500</li> <li>— SHUTTER 1/1000</li> <li>— SHUTTER 1/2000</li> </ul>
	(Continued)	(Continued)	

1) Only for the DSR-450WS/450WSP

2) Only for 24P mode

3) Only for PsF (progressive scan) mode and a video output signal set to PAL

4) Only for PsF (progressive scan) mode and a video output signal set to NTSC

5) Only for I (interlace scan) mode and a video output signal set to PAL, or for PsF (progressive scan) mode and a video output signal set to NTSC

6) Only for I (interlace scan) mode and a video output signal set to NTSC, or for PsF (progressive scan) mode and a video output signal set to PAL

Menu selection	1st hierarchy	2nd hierarchy	3rd hierarchy
		LENS FILE	LENS FILE SELECT F.ID
		FORMAT	16:9/4:3 SELECT <sup>2)</sup> WIDE ID <sup>2)</sup> SCAN MODE <sup>2)</sup> 24P PULLDWN MODE <sup>3)</sup> DF/NDF <sup>3)</sup>
		SOURCE SEL <sup>1)</sup>	REC VIDEO SOURCE SETUP REMOVE <sup>3)</sup>
	• PAINT	SW STATUS	GAMMA CHROMA MATRIX KNEE WHITE CLIP DETAIL APERTURE FLARE EVS TEST SAW
		WHITE	COLOR TEMP <A> COLOR FINE <A> R GAIN <A> B GAIN <A> D5600K <A> COLOR TEMP <B> COLOR FINE <B> R GAIN <B> B GAIN <B> D5600K <B>
		BLACK/FLARE	MASTER BLACK R BLACK B BLACK MASTER FLARE R FLARE G FLARE B FLARE FLARE
		GAMMA	GAMMA STEP GAMMA MASTER GAMMA R GAMMA G GAMMA B GAMMA GAMMA SELECT <sup>2)</sup> GAMMA SEL(STD) GAMMA SEL(FILM) <sup>2)</sup>
		BLACK GAMMA	BLACK GAMMA BLK GAM RANGE MASTER BLK GAMMA R BLACK GAMMA G BLACK GAMMA B BLACK GAMMA
		KNEE	KNEE KNEE POINT KNEE SLOPE KNEE SATURATION KNEE SAT LEVEL WHITE CLIP WHITE CLIP LEVEL
		DETAIL 1	DETAIL APERTURE DETAIL LEVEL APERTURE LEVEL DTL H/V RATIO CRISPENING LEVEL DEPEND LEVEL DEPEND LVL DETAIL FREQUENCY
	(Continued)	(Continued)	

1) Only when a CBK-SC01 Composite Input Board is installed in the DSR-450WS/450WSP

2) Only for the DSR-450WS/450WSP

3) Only for the DSR-450WS

Menu selection	1st hierarchy	2nd hierarchy	3rd hierarchy
		DETAIL 2	<ul style="list-style-type: none"> <li>— KNEE APERTURE</li> <li>— KNEE APT LVL</li> <li>— DETAIL COMB</li> <li>— CROSS COLOR</li> <li>— CROSS COLOR LVL</li> <li>— DETAIL LIMIT</li> <li>— DTL WHT LMT</li> <li>— DTL BLK LMT</li> <li>— DTL V-BLK LMT</li> </ul>
		DETAIL 3	<ul style="list-style-type: none"> <li>— FINE DTL</li> <li>— FINE DTL LVL</li> <li>— V DTL CREATION</li> <li>— H/V CONTROL MODE</li> </ul>
		SKIN DETAIL	<ul style="list-style-type: none"> <li>— SKIN DETAIL ALL</li> <li>— SKIN DETECT</li> <li>— SKIN AREA IND</li> <li>— SKIN DTL SELECT</li> <li>— SKIN DETAIL</li> <li>— SKIN DETAIL LVL</li> <li>— SKIN DTL SAT</li> <li>— SKIN DTL HUE</li> <li>— SKIN DTL WIDTH</li> </ul>
		MTX LINEAR	<ul style="list-style-type: none"> <li>— MATRIX</li> <li>— MATRIX(USER)</li> <li>— MATRIX(PRESET)</li> <li>— MATRIX R-G</li> <li>— MATRIX R-B</li> <li>— MATRIX G-R</li> <li>— MATRIX G-B</li> <li>— MATRIX B-R</li> <li>— MATRIX B-G</li> </ul>
		MTX MULTI	<ul style="list-style-type: none"> <li>— MATRIX</li> <li>— MATRIX(MULTI)</li> <li>— MATRIX AREA IND</li> <li>— MATRIX COLOR DET</li> <li>— MTX(MULTI)AXIS</li> <li>— MTX(MULTI)HUE</li> <li>— MTX(MULTI)SAT</li> </ul>
		V MODULATION	<ul style="list-style-type: none"> <li>— VMOD</li> <li>— MASTER VMOD</li> <li>— R VMOD</li> <li>— G VMOD</li> <li>— B VMOD</li> </ul>
		LOW KEY SAT	<ul style="list-style-type: none"> <li>— LOW KEY SAT</li> <li>— L.KEY SAT LEVEL</li> <li>— L.KEY SAT RANGE</li> <li>— Y BLACK GAMMA</li> <li>— Y BLK GAM LEVEL</li> <li>— Y BLK GAM RANGE</li> </ul>
		SCENE FILE	<ul style="list-style-type: none"> <li>— <input type="checkbox"/> 1</li> <li>— <input type="checkbox"/> 2</li> <li>— <input type="checkbox"/> 3</li> <li>— <input type="checkbox"/> 4</li> <li>— <input type="checkbox"/> 5</li> <li>— <input type="checkbox"/> STANDARD</li> <li>— SCENE RECALL</li> <li>— SCENE STORE</li> <li>— F. ID</li> </ul>
	• MAINTENANCE	WHITE SHADING	<ul style="list-style-type: none"> <li>— WHT SHAD CH SEL</li> <li>— R/G/B WHT H SAW</li> <li>— R/G/B WHT H PARA</li> <li>— R/G/B WHT V SAW</li> <li>— R/G/B WHT V PARA</li> <li>— WHITE SAW/PARA</li> </ul>
(Continued)		(Continued)	

Menu selection	1st hierarchy	2nd hierarchy	3rd hierarchy
		BLACK SHADING	<ul style="list-style-type: none"> <li>— BLK SHAD CH SEL</li> <li>— R/G/B BLK H SAW</li> <li>— R/G/B BLK H PARA</li> <li>— R/G/B BLK V SAW</li> <li>— R/G/B BLK V PARA</li> <li>— BLACK SAW/PARA</li> <li>— MASTER BLACK</li> <li>— MASTER GAIN(TMP)</li> </ul>
		BATTERY	<ul style="list-style-type: none"> <li>— &lt;Sony Info&gt;</li> <li>— BEFORE END 1</li> <li>— END1</li> <li>— &lt;Sony&gt;</li> <li>— BEFORE END 2</li> <li>— END 2</li> <li>— &lt;Others, EXT DC&gt;</li> <li>— BEFORE END 3</li> <li>— END 3</li> </ul>
		AUDIO	<ul style="list-style-type: none"> <li>— AU MODE</li> <li>— AU HEADROOM</li> <li>— AU FADE</li> <li>— AU SG(1KHz)</li> <li>— F AUDIO VOL</li> </ul>
		VTR MODE	<ul style="list-style-type: none"> <li>— REC TALLY BLINK</li> <li>— STBY OFF TIMER</li> <li>— REC FORMAT</li> <li>— SETUP ADD <sup>1)</sup></li> </ul>
		PRESET WHT	<ul style="list-style-type: none"> <li>— COLOR TEMP &lt;P&gt;</li> <li>— COLOR FINE &lt;P&gt;</li> <li>— R GAIN &lt;P&gt;</li> <li>— B GAIN &lt;P&gt;</li> <li>— D5600K &lt;P&gt;</li> <li>— AWB ENABLE &lt;P&gt;</li> </ul>
		DCC ADJUST	<ul style="list-style-type: none"> <li>— DCC FUNCTION SEL</li> <li>— DCC D RANGE</li> <li>— DCC POINT</li> <li>— DCC GAIN</li> <li>— DCC DELAY TIME</li> </ul>
		AUTO IRIS 2	<ul style="list-style-type: none"> <li>— IRIS WINDOW</li> <li>— IRIS WINDOW IND</li> <li>— IRIS LEVEL</li> <li>— IRIS APL RATIO</li> <li>— IRIS VAR WIDTH</li> <li>— IRIS VAR HEIGHT</li> <li>— IRIS VAR H POS</li> <li>— IRIS VAR V POS</li> <li>— IRIS SPEED</li> <li>— CLIP HIGH LIGHT</li> </ul>
		FUNCTION 3	<ul style="list-style-type: none"> <li>— WHT FILTER INH</li> <li>— COLOR BAR SEL</li> <li>— REC TALLY</li> <li>— USER &amp; ALL ONLY</li> <li>— RM COMMON MEMORY <sup>2)</sup></li> <li>— RM REC START <sup>2)</sup></li> <li>— i.LINK CTL</li> <li>— i.LINK CTL(END)</li> </ul>
		GENLOCK	<ul style="list-style-type: none"> <li>— GENLOCK</li> <li>— GL H PHASE</li> <li>— GL SC PHASE</li> <li>— GL SC 0/180 SEL</li> </ul>
		ND COMP	<ul style="list-style-type: none"> <li>— ND OFFSET ADJUST</li> <li>— CLEAR ND OFFSET</li> </ul>
		AUTO SHADING	<ul style="list-style-type: none"> <li>— AUTO BLK SHADING</li> <li>— RESET BLK SHD</li> <li>— MASTER GAIN(TMP)</li> </ul>

(Continued)

1) Only for the DSR-400/450WS

2) Only for the DSR-450WS/450WSP



Menu selection	1st hierarchy	2nd hierarchy	3rd hierarchy
	• FILE	USER FILE	<ul style="list-style-type: none"> <li>USER FILE LOAD</li> <li>USER FILE SAVE</li> <li>F. ID</li> <li>USER PRESET</li> </ul>
		USER FILE 2	<ul style="list-style-type: none"> <li>STORE USR PRESET</li> <li>CLEAR USR PRESET</li> <li>CUSTOMIZE RESET</li> <li>LOAD CUSTOM DATA</li> <li>LOAD OUT OF USER</li> <li>BEFORE FILE PAGE</li> <li>USER LOAD WHITE</li> </ul>
		ALL FILE	<ul style="list-style-type: none"> <li>ALL FILE LOAD</li> <li>ALL FILE SAVE</li> <li>F. ID</li> <li>ALL PRESET</li> <li>STORE ALL PRESET</li> <li>CLEAR ALL PRESET</li> </ul>
		SCENE FILE	<ul style="list-style-type: none"> <li><input type="checkbox"/> 1</li> <li><input type="checkbox"/> 2</li> <li><input type="checkbox"/> 3</li> <li><input type="checkbox"/> 4</li> <li><input type="checkbox"/> 5</li> <li><input type="checkbox"/> STANDARD</li> <li>SCENE RECALL</li> <li>SCENE STORE</li> <li>F. ID</li> </ul>
		REFERENCE	<ul style="list-style-type: none"> <li>REFERENCE STORE</li> <li>REFERENCE CLEAR</li> <li>REFERENCE LOAD</li> <li>REFERENCE SAVE</li> <li>F. ID</li> <li>SCENE WHITE DATA</li> </ul>
		LENS FILE 1	<ul style="list-style-type: none"> <li>LENS FILE RECALL</li> <li>LENS FILE STORE</li> <li>F. ID</li> <li>LENS NO OFFSET</li> <li>SOURCE</li> <li>IRIS GAIN</li> </ul>
		LENS FILE 2	<ul style="list-style-type: none"> <li>LENS M VMOD</li> <li>LENS CENTER H</li> <li>LENS CENTER V</li> <li>LENS R FLARE</li> <li>LENS G FLARE</li> <li>LENS B FLARE</li> <li>LENS W-R OFST</li> <li>LENS W-B OFST</li> </ul>
		LENS FILE 3	<ul style="list-style-type: none"> <li>SHADING CH SEL</li> <li>LENS R/G/B H SAW</li> <li>LENS R/G/B H PARA</li> <li>LENS R/G/B V SAW</li> <li>LENS R/G/B V PARA</li> </ul>
		MEMORY STICK	<ul style="list-style-type: none"> <li>M.S. FORMAT</li> <li>M.S. IN &gt; JUMP TO</li> </ul>

(Continued)

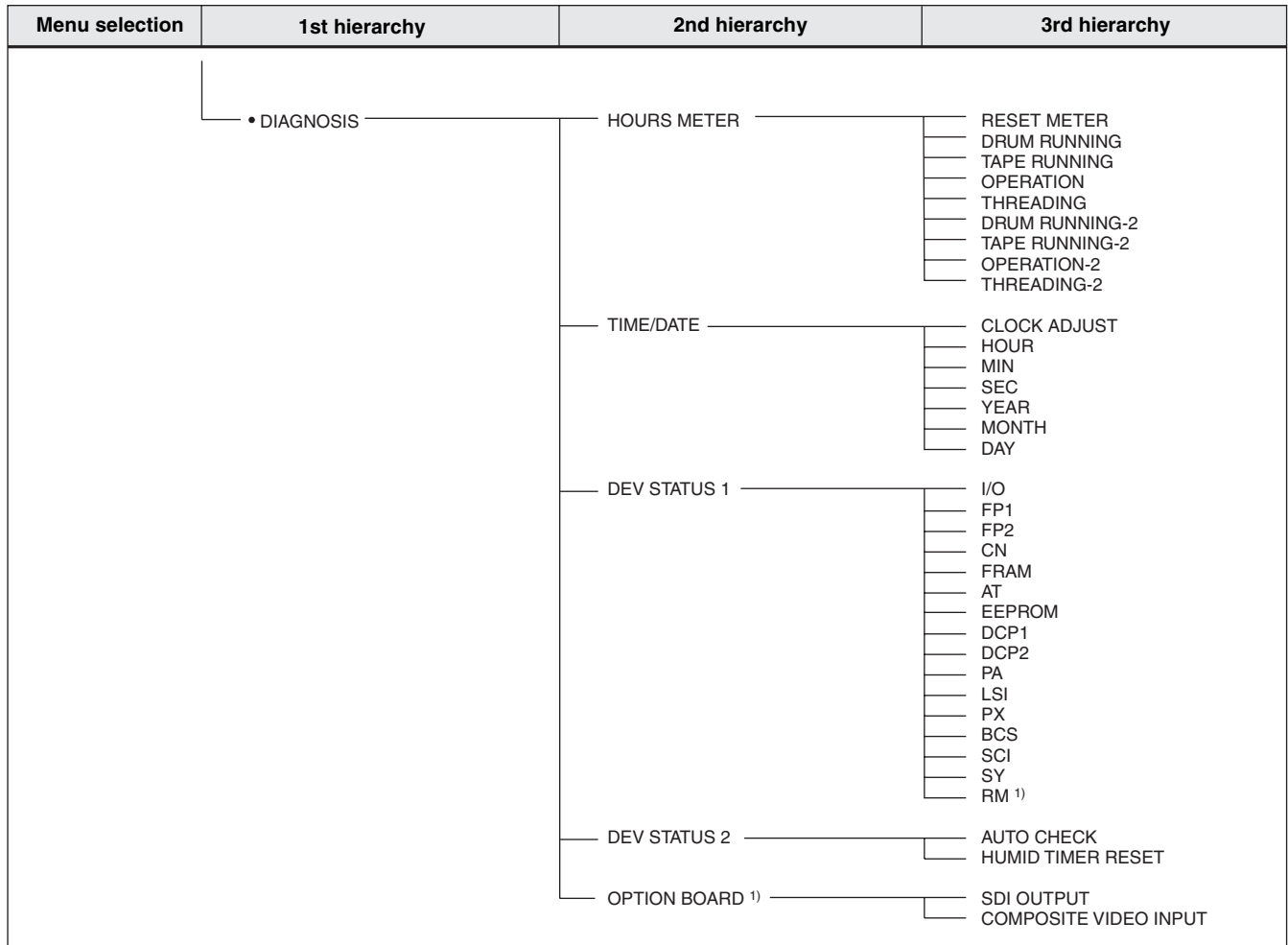

1) Only for the DSR-450WS/450WSP

## The TOP menu

The TOP menu consists of the following submenus.

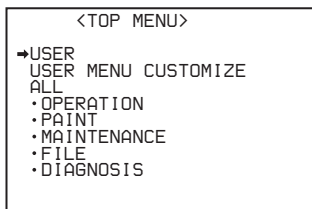

When you select an item in the TOP menu, this displays the most recently shown page of the corresponding submenu. When the submenu is selected for the first time, the CONTENTS page appears.

## The USER menu

This menu allows you to add items from the OPERATION, PAINT, MAINTENANCE, FILE, and DIAGNOSIS menus to suit your needs. By gathering frequently used items on the USER menu beforehand, you can call up them quickly whenever you need them. Usually by flicking the MENU switch to ON, the USER menu is displayed.

## The USER MENU CUSTOMIZE menu

This menu allows you to add pages to or delete pages from the USER menu to suit your needs.

## The ALL menu

This menu contains all items of the OPERATION, PAINT, MAINTENANCE, FILE, and DIAGNOSIS menus as they are in one menu.

## The OPERATION menu

This menu contains items for changing settings according to conditions related to the subject when the camcorder is being operated.

## The PAINT menu

This menu contains items for making detailed image adjustments while using a waveform monitor to monitor the waveforms output by the camera. Support of a video engineer is usually required to use this menu. Although you can also use an external remote control unit to set the items on this menu, this menu is effective when using the camcorder by itself outdoors.

## The MAINTENANCE menu

This menu contains items for performing camera maintenance operations, such as changing the VTR system or using infrequently used paint items.

## The FILE menu

This menu is for saving the adjusted data in the camcorder memory or in a “Memory Stick”. The following files can be saved.

### The user file

In the user file, the setting items and setting data of the customized USER menu are saved. Once you save the user file in a “Memory Stick”, you can easily set the USER menu to your preference by loading the data from the “Memory Stick”.

*For details on the user file, see “Saving and Loading User Files” on page 110.*

### The ALL file

In the ALL file, the setting data of all of the menus are saved. Once a camcorder is set according to your preferences and you save its ALL file in a “Memory Stick”, you can easily set other camcorders to the settings of the camcorder that you already set by loading the data from the “Memory Stick”.

*Items included in the ALL file are marked with an “A” in the “File” column on the menu list.*

### The preset file

In the preset file, the preset values of setting items in the menu are saved. You can save the preset file in the built-in memory of the camcorder.

*Items included in the preset file are marked with a “P” in the “File” column on the menu list.*

## The scene file

In the scene file, the setting values of event items adjusted to shoot a particular scene are saved. You can save up to five scene files in the camcorder memory and up to 100 scene files in a “Memory Stick”. For example, first adjust the settings to shoot a particular scene at the rehearsal and then save them as a scene file. Then load this file before the actual shooting so that you can quickly recreate setup conditions that are the same as those in rehearsal.

*Items included in the scene file are marked with an “Sc” in the “File” column on the menu list.*

## The reference file

In the reference file, the reference setting values used when executing SCENE FILE STANDARD (page 117) are saved. You can save one reference file in a “Memory Stick”. If the reference file is not saved, the factory default values are used as reference values.

*Items included in the reference file are marked with an “R” in the “File” column on the menu list.*

## The lens file

In the lens file, the setting data used to compensate for the characteristics of lenses, such as flare, white shading, auto iris gain, center marker position, and compensation value of extender white, is saved. You can save up to 16 lens files in the camcorder memory and up to 100 lens files in a “Memory Stick”.

*Items included in the lens file are marked with an “L” in the “File” column on the menu list.*

## The DIAGNOSIS menu

This menu enables you to confirm the VTR status or identify a failed circuit board.

## Menu list

The pages of the menu that have been registered in the USER menu at the factory are indicated by the page (Page1 to 8) in the “USER menu” column.

The USER MENU CUSTOMIZE menu allows you to add and delete pages in the USER menu to suit your requirements.

### Note

When the setting range in the “Settings” column is surrounded by parentheses ( ), the setup value is a relative

value. The setting range shown on the menu screen may differ from what is shown in the manual.

### The “File” column

The letters in the “File” column stand for the following.

**A:** Items saved in the ALL file

**P:** Items saved in the preset file

**Sc:** Items saved in the scene file

**R:** Items saved in the reference file

**L:** Items saved in the lens file

**St:** Items changed in value by the STANDARD operation

### The OPERATION menu

Page	Item	Settings	Default	USER menu	Description	File
OUTPUT	LCD BRIGHT <L>	-32 to 31	0	-	Adjusts brightness of the LCD monitor when the LCD button is set to L.	A P
	LCD BRIGHT <H>				Adjusts brightness of the LCD monitor when the LCD button is set to H.	
	LCD COLOR				Adjusts the color strength of the LCD monitor.	
	REAR BNC OUT SEL (when option board is installed)	VBS/SDI	VBS	Page4	See “ <i>Selecting the output signals (DSR-450WS/450WSP only)</i> ” on page 105.	
MONITOR OUT	MONI OUT VFDISP	OFF/ON	ON	-	Selects whether or not the VF DISP display signal is mixed to the output signal from the MONITOR OUT connector.	A P
	MONI OUT MENU				Selects whether or not the MENU display signal is mixed to the output signal from the MONITOR OUT connector.	
	MONI OUT TC		OFF		Selects whether or not the time code is mixed to the output signal from the MONITOR OUT connector.	
	MONI OUT MARKER		Selects whether or not the marker signal is mixed to the output signal from the MONITOR OUT connector.			
	MONI OUT ZEBRA		Selects whether or not the ZEBRA display signal is mixed to the output signal from the MONITOR OUT connector.			

Page	Item	Settings	Default	USER menu	Description	File
FUNCTION 1	ASSIGN SW <1>	OFF/ MARKER/ ATW/LENS	ATW	Page7	See "Assigning functions to ASSIGN switches" on page 107.	A P
	ASSIGN SW <2>	RET/REC	OFF			
	ASSIGN SW <3>	SWITCH/ TURBO				
	ASSIGN SW <4>	SWITCH				
	DF/NDF	DF/NDF	DF	–	Switches between drop frame (DF) mode and non-drop frame (NDF) mode.	
	INTERVAL REC	OFF/ON	OFF		See "Time-Lapse Video (Interval Rec)" on page 64.	
	REC TIME	0.5S/1.0S/ 1.5S/2.0S/5S/ 10S/30S/1M/ 5M/10M	0.5S			
	INTERVAL TIME	30S/1M/5M/ 10M/30M/1H	1H			
PRE-LIGHTING	OFF/2SEC/ 5SEC/10SEC	OFF				
FUNCTION 2	D5600	OFF/ON	OFF	–	Turns on and off the function which electrically applies a 5600K color temperature filter (effective only when WIDE AWB is set to OFF).	A P Sc St
	WIDE AWB	OFF/ON	ON		Turns on and off the function which widens the range adjustable by Auto White Balance.	A P
	WHITE SWTCH <B>	MEM/ATW	MEM		Sets the function of the WHITE BAL switch when it is set to B.	
	SHOCKLESS WHITE	OFF/1/2/3	1		Changes the white gain smoothly when operating the WHITE BAL switch.	
	ATW SPEED	1/2/3/4/5	4		Sets the convergence speed for Auto Tracing White balance.	
	LOW LIGHT	OFF/ON	OFF		Turns the warning display on or off when the video average level is less than the preset value.	
	LOW LIGHT LEVEL	(–99 to 99)	0		Sets the level at which the LOW LIGHT function becomes effective.	
	VF BATT WARNING	10% / 20%	10%		Sets the threshold value of remaining battery capacity to make the remaining capacity indication flash on the viewfinder screen.	
VF DISP 1	VF DISP	OFF/ON	Depends on the switch	–	See "Selecting the display items" on page 99.	–
	VF DISP MODE	1/2/3	3			A P
	DISP EXTENDER	OFF/ON	ON			
	DISP FILTER					
	DISP WHITE					
	DISP GAIN					
	DISP SHUTTER					
	DISP AUDIO					
	DISP TAPE					
DISP IRIS						

Page	Item	Settings	Default	USER menu	Description	File
VF DISP 2	DISP COLOR TEMP	OFF/ON	OFF	-	See "Selecting the display items" on page 99.	A P
	DISP BATT REMAIN	AUTO/VOLT/ INT	INT			
	DISP DC IN	OFF/ON	OFF			
	DISP 16:9/4:3 ID					
	DISP VTR STATUS	OFF/ON	ON			
	DISP VTR TRIGGER					
	DISP TIME CODE	OFF/ON	OFF			
	DISP REC FORMAT					
MARKER 1	MARKER	OFF/ON	OFF	Page6	See "Setting the marker display" on page 101.	A P
	CENTER					
	SAFETY ZONE					
	SAFETY AREA	80% / 90% / 92% / 95%	90%	-		
	ASPECT	OFF/ON	OFF			
	ASPECT SELECT	4:3/13:9/14:9	4:3			
	ASPECT MASK (4:3)	OFF/ON	OFF			
	ASPECT MASK LVL	1/2, 1/4, 1/8	1/4			
	100% MARKER	OFF/ON	OFF			
MARKER 2	USER BOX	OFF/ON	OFF	-	Turns the box cursor on or off.	A P
	USER BOX WIDTH	1 to 465	245		Width (from the center to right or left side)	
	USER BOX HEIGHT	NTSC: 1 to 120 PAL: 1 to 142	72		Height (from the center to top or bottom)	
	USER BOX H POS	-461 to 461	0		Horizontal position of the center	
	USER BOX V POS	NTSC: -119 to 118 PAL: -141 to 140	0		Vertical position of the center	
	CENTER H POS	-48 to 47	0		Horizontal position of the center marker	
	CENTER V POS	-15 to 14	0		Vertical position of the center marker	
GAIN SW	GAIN LOW	-3dB/0dB/3dB/ 6dB/9dB/12dB/ 18dB/24dB/ 30dB/36dB	0dB	-	See "Setting gain values for the GAIN switch positions" on page 104.	A P
	GAIN MID		9dB			
	GAIN HIGH		18dB			
	GAIN TURBO		36dB			
	TURBO SW IND	OFF/ON	OFF			
VF SETTING	ZEBRA	OFF/ON	OFF	-	See "Setting the viewfinder" on page 101.	A P
	ZEBRA SELECT	1/2/BOTH	1			
	ZEBRA1 DET LVL	20% to 107% (in 1% steps)	70%			
	ZEBRA1 APT LVL	1% to 10% (in 1% steps)	10%			
	ZEBRA2 DET LVL	52% to 109% (in 1% steps)	100%			
	VF DETAIL LEVEL	(-99 to 99)	0			
	VF ASPECT	AUTO/16:9	AUTO			

Page	Item	Settings	Default	USER menu	Description	File
AUTO IRIS	IRIS OVERRIDE	OFF/ON	OFF	Page1	See "Adjusting the iris" on page 56.	A P
	IRIS SPEED	(-99 to 99)	0	-	Adjusts the speed of automatic iris.	A P Sc R St
	CLIP HIGH LIGHT	OFF/ON	OFF		Turns the function that ignores detection of very bright highlights or reacts slowly to them on or off.	A P
	IRIS WINDOW	1/2/3/4/5/VAR	1		See "Adjusting the iris" on page 56.	A P R St
	IRIS WINDOW IND	OFF/ON	OFF			-
	IRIS VAR WIDTH	20 to 465	245			A P
	IRIS VAR HEIGHT	NTSC: 20 to 120 PAL: 20 to 142	NTSC: 72 PAL: 85			
	IRIS VAR H POS	-452 to 452	0			
IRIS VAR V POS	NTSC: -101 to 100 PAL: -122 to 122	0				
SHOT ID	ID-1	Displays character input mode (up to 12 characters).	Blank	-	See "Setting the shot ID" on page 102.	A
	ID-2					
	ID-3					
	ID-4					
SHOT DISP	SHOT DATE	OFF/ON	OFF	-	See "Recording shot data superimposed on the color bars" on page 102.	A P
	SHOT TIME					
	SHOT MODEL NAME					
	SHOT SERIAL NO					
	SHOT ID SEL	OFF/ID-1/ID-2/ID-3/ID-4				
	SHOT 16:9 ID	OFF/ON	OFF			
	SHOT BLINK CHARA		OFF			
SET STATUS	STATUS CAMERA	OFF/ON	ON	-	See "Displaying the status confirmation windows" on page 103.	A P
	STATUS VTR					
OFFSET WHT	OFFSET WHITE <A>	OFF/ON	OFF	-	See "Specifying an offset for the auto white balance setting" on page 106.	A P
	WARM-COOL <A>	Display color temperature (converted from R/B Gain).	3200			
	COLOR FINE <A>	(-99 to 99)	0			
	OFFSET WHITE <B>	OFF/ON	OFF			
	WARM-COOL <B>	Display color temperature (converted from R/B Gain).	3200			
	COLOR FINE <B>	(-99 to 99)	0			

Page	Item	Settings	Default	USER menu	Description	File
SHT ENABLE	SHUTTER SLS	OFF/ON	ON	-	See "To select the shutter mode and shutter speed" on page 54. The items which can be set differ depending on the CCD scan mode setting (page 109).	A P
	SHUTTER ECS					
	SHUTTER 1/32					
	SHUTTER 1/33					
	SHUTTER 1/40					
	SHUTTER 1/48					
	SHUTTER 1/50					
	SHUTTER 1/60					
	SHUTTER 1/96					
	SHUTTER 1/100					
	SHUTTER 1/120					
	SHUTTER 1/125					
	SHUTTER 1/250					
	SHUTTER 1/500					
	SHUTTER 1/1000					
SHUTTER 1/2000						
LENS FILE	LENS FILE SELECT	1 to 17 (17 only when serial lens connected)	1	-	See "Selecting the lens file" on page 107.	-
	F.ID	Displays file name.	Blank			L
FORMAT	16:9/4:3 SELECT	16:9 / 4:3	16:9	Page4	See "Selecting the aspect ratio (DSR-450WS/450WSP only)" on page 107.	A P
	WIDE ID	OFF/ON	ON	-	Selects whether to add wide aspect identifying signal to video signal in 16:9 mode.	
	SCAN MODE	NTSC: I/PsF/ 24P PAL: I/PsF	I	Page4	See "Setting the CCD scan mode (DSR-450WS/450WSP only)" on page 108.	A P Sc R St
	24P PULLDWN MODE	2.3/2.3.3.2	2.3	-	Selects the pulldown method when the scan mode is set to 24P.	AP
	DF/NDF	DF/NDF	DF		Switches between drop frame (DF) mode and non-drop frame (NDF) mode.	
SOURCE SEL	REC VIDEO SOURCE	CAM/EXT	CAM	Page4	See "Recording Analog Composite Signals (with a CBK-SC01 Installed-DSR-450WS/450WSP only)" on page 65.	A P
	SETUP REMOVE	OFF/ON	ON	-		



## The PAINT menu

Page	Item	Settings	Default	USER menu	Description	File	
SW STATUS	GAMMA	OFF/ON	ON	-	Turns the gamma correction on or off.	A P Sc St	
	CHROMA				Turns the chroma of the composite signal on or off.		
	MATRIX				Turns the linear matrix correction on or off.		A P Sc R St
	KNEE				Turns the knee correction on or off.		
	WHITE CLIP				Turns the white clipping correction on or off.	A P Sc St	
	DETAIL				Turns the detail signal on or off.		
	APERTURE				Turns the aperture function on or off.		
	FLARE				Turns the flare function on or off.		
	EVS				OFF	OFF	OFF
	TEST SAW	OFF/SAW/REC	OFF	OFF	Selects the test signal.	A P St	
WHITE	COLOR TEMP <A>	Display color temperature (converted from R/B gain).	3200	-	Sets the color temperature of WHITE A.	A P Sc St	
	COLOR FINE <A>	(-99 to 99)	0		Adjusts the value more precisely when the color temperature adjustment through COLOR TEMP is not satisfactory.		
	R GAIN <A>				Only the value of R GAIN is changed.		
	B GAIN <A>				Only the value of B GAIN is changed.		
	D5600K <A>	OFF/ON	OFF		OFF		Turns the WHITE A electronic 5600K filter on or off.
	COLOR TEMP <B>	Display color temperature (converted from R/B gain).	3200		Sets the color temperature of WHITE B.		
	COLOR FINE <B>	(-99 to 99)	0		Adjusts the value more precisely when the color temperature adjustment through COLOR TEMP is not satisfactory.		
	R GAIN <B>				Only the value of R GAIN is changed.		
	B GAIN <B>				Only the value of B GAIN is changed.		
	D5600K <B>	OFF/ON	OFF		OFF		Turns the WHITE B electronic 5600K filter on or off.
BLACK/FLARE	MASTER BLACK	(-99 to 99)	0	Page1	Adjusts the black level of the master.	A P Sc R St	
	R BLACK			-	Adjusts the R black level.		A P Sc St
	B BLACK			Adjusts the B black level.			
	MASTER FLARE			Adjusts the flare level of the master.	A P Sc R St		
	R FLARE			Adjusts the R flare level.			
	G FLARE			Adjusts the G flare level.			
	B FLARE			Adjusts the B flare level.			
	FLARE	OFF/ON	ON	ON	Turns the flare correction circuit on or off.	A P Sc St	

Page	Item	Settings	Default	USER menu	Description	File	
GAMMA	GAMMA	OFF/ON	ON	–	Turns the gamma correction function on or off.	A P Sc St	
	STEP GAMMA	0.35 to 0.90 (in 0.05 steps)	0.45		Sets the master gamma correction curve in steps.	A P Sc R St	
	MASTER GAMMA	(–99 to 99)	0		Sets the master gamma correction curve.		
	R GAMMA				Sets the R gamma correction curve.		
	G GAMMA				Sets the G gamma correction curve.		
	B GAMMA				Sets the B gamma correction curve.		
	GAMMA SELECT	STD/FILM	STD		Selects the gamma table.		
	GAM SEL (STD)	1 to 6	3		Selects the gamma table of STD.		
GAM SEL (FILM)	1 to 5	1		Selects the gamma table of FILM.			
BLACK GAMMA	BLACK GAMMA	OFF/ON	ON	Page1	Turns the black gamma correction on or off.	A P Sc R St	
	BLK GAMMA RANGE	LOW/L.MID/ H.MID/HIGH	HIGH	–	Sets the range affected by black gamma.		
	MASTER BLK GAMMA	(–99 to 99)	0	Page1	Adjusts the black gamma of the master.		
	R BLACK GAMMA			–	Sets the correction curve of the R black gamma.		
	G BLACK GAMMA				Sets the correction curve of the G black gamma.		
	B BLACK GAMMA				Sets the correction curve of the B black gamma.		
KNEE	KNEE	OFF/ON	ON	–	Turns the knee correction circuit on or off.	A P Sc R St	
	KNEE POINT	50.0 to 109.0 (in 0.1 steps)	100.0		Sets the knee point level.		
	KNEE SLOPE	(–99 to 99)	0		Set the knee slope level.		
	KNEE SATURATION	OFF/ON	ON		Turns the knee saturation function on or off.		
	KNEE SAT LEVEL	(–99 to 99)	0		Sets the knee saturation level.		
	WHITE CLIP	OFF/ON	ON		Turns the white clipping function on or off.		A P Sc St
	WHITE CLIP LEVEL	100.0 to 109.5 (in 0.1 steps)	NTSC: 109.0 PAL: 105.0		Adjusts the white clipping level.		A P Sc R St

Page	Item	Settings	Default	USER menu	Description	File
DETAIL 1	DETAIL	OFF/ON	ON	–	Turns the detail correction function on or off.	A P Sc St
	APERTURE				Turns the aperture correction function on or off.	
	DETAIL LEVEL	(–99 to 99)	0	Page1	Sets the general level of the detail signal.	A P Sc R St
	APERTURE LEVEL			–	Sets the aperture level.	
	DTL H/V RATIO				Sets the level of the V detail signal.	
	CRISPENING				Sets the crispening level.	
	LEVEL DEPEND	OFF/ON	ON		Turns the level depend function on or off.	
	LEVEL DEPEND LVL	(–99 to 99)	0		Sets the level of the level depend.	
DETAIL FREQUENCY				Sets the frequency of the H detail signal.		
DETAIL 2	KNEE APERTURE	OFF/ON	OFF	–	Turns the knee aperture function on or off.	A P Sc R St
	KNEE APT LVL	(–99 to 99)	0		Sets the knee aperture level.	
	DETAIL COMB	–99 to 0			Sets the level at which the comb filter becomes effective.	
	CROSS COLOR	OFF/ON	OFF		Turns the cross color component on or off.	
	CROSS COLOR LVL	0 to 99	43		Sets the suppression level of the cross color.	
	DETAIL LIMIT	(–99 to 99)	0		Sets the both detail black and white limiters.	
	DTL WHT LMT				Sets the detail white limiter.	
	DTL BLK LMT				Sets the detail black limiter.	
DTL V-BLK LMT				Sets the V detail black limiter.		
DETAIL 3	FINE DTL	OFF/ON	OFF	–	Turns the fine detail function on or off.	A P Sc R St
	FINE DTL LVL	(–99 to 99)	0		Sets the level at which the fine detail function becomes effective.	
	V DTL CREATION	NAM/G/R+G/Y	R+G		Selects the source signal of the V DTL signal.	
	H/V CONTROL MODE	H/V, V	V		Select the operation mode of DETAIL H/V RATIO on the DETAIL 1 page. (H/V: H and V both enabled, V: V DTL only enabled)	
SKIN DETAIL	SKIN DETAIL ALL	OFF/ON	OFF	Page2	Sets ON or OFF of all the skin detail.	A P Sc R St
	SKIN DETECT	Moves to color detection page.	EXEC		Detects the color for skin detail ( <i>page 61</i> ).	
	SKIN AREA IND	OFF/ON	OFF		Sets the indicator of detected color.	St
	SKIN DTL SELECT	1/2/3	1		Selects the skin detail.	A P Sc R St
	SKIN DETAIL	OFF/ON	ON		Sets ON or OFF of the skin detail selected in SKIN DTL SELECT.	
	SKIN DETAIL LVL	(–99 to 99)	0		Sets the detail level of detected color.	
	SKIN DTL SAT			–	Adjusts the saturation level for skin detail.	
	SKIN DTL HUE				Adjusts the center phase for skin detail.	
SKIN DTL WIDTH	0 to 359	40		Adjusts the width for skin detail.		

Page	Item	Settings	Default	USER menu	Description	File
MTX LINEAR	MATRIX	OFF/ON	ON	–	Turns the linear matrix correction and user set matrix correction functions on or off.	A P Sc R St
	MATRIX (USER)		OFF		Turns the user-set matrix correction function on or off.	
	MATRIX (PRESET)		ON		Turns the preset matrix correction function on or off.	
	MATRIX R-G	(–99 to 99)	0		Sets the arbitrary R-G user-set matrix coefficients.	
	MATRIX R-B				Sets the arbitrary R-B user-set matrix coefficients.	
	MATRIX G-R				Sets the arbitrary G-R user-set matrix coefficients.	
	MATRIX G-B				Sets the arbitrary G-B user-set matrix coefficients.	
	MATRIX B-R				Sets the arbitrary B-R user-set matrix coefficients.	
	MATRIX B-G				Sets the arbitrary B-G user-set matrix coefficients.	
MTX MULTI	MATRIX	OFF/ON	ON	–	Turns the linear matrix correction and multi matrix correction functions on or off.	A P Sc R St
	MATRIX (MULTI)		OFF		Turns the multi matrix correction function on or off.	
	MATRIX AREA IND	OFF/ON	OFF		Turns the zebra indication on or off in the area corresponding to the currently selected setting.	St
	MATRIX COLOR DET	Moves to color detection page.	EXEC		Detects color.	–
	MTX (MULTI) AXIS	B/B+/MG–/MG/MG+/R/R+/YL–/YL/YL+/G–/G/G+/CY/CY+/B–	B		Sets the region in which the multi matrix correction function can be changed.	P St
	MTX (MULTI) HUE	(–99 to 99)	0		Adjusts the color phase affected by the multi matrix correction function in every sixteen axis mode.	A P Sc R St
	MTX (MULTI) SAT				Adjusts the saturation level affected by the multi matrix correction function in every sixteen-axis mode.	
V MODULATION	V MOD	OFF/ON	ON	–	Turns the V modulation function on or off.	A P St
	MASTER VMOD	(–99 to 99)	0		Turns the master V modulation function on or off.	A P Sc R St
	R VMOD				Turns the R V modulation function on or off.	
	G VMOD				Turns the G V modulation function on or off.	
	B VMOD				Turns the B V modulation function on or off.	

Page	Item	Settings	Default	USER menu	Description	File
LOW KEY SAT	LOW KEY SAT	OFF/ON	OFF	–	Turns the low key saturation function on or off.	A P Sc R St
	L.KEY SAT LEVEL	(–99 to 99)	0		Sets the saturation level of the low luminance part.	
	L.KEY SAT RANGE	LOW/L.MID/ H.MID/HIGH	HIGH		Sets the luminance level at which the low key saturation function becomes effective.	
	Y BLACK GAMMA	OFF/ON	OFF		Turns the Y black gamma function on or off.	
	Y BLK GAM LEVEL	(–99 to 99)	0		Sets the gamma curve in the low luminance part.	
	Y BLK GAM RANGE	LOW/L.MID/ H.MID/HIGH	HIGH		Sets the luminance level at which the Y black gamma becomes effective.	
SCENE FILE	<input type="checkbox"/> 1	–	STAN- DARD	Page3	Recalls the scene file saved in the memory of the camcorder.	–
	<input type="checkbox"/> 2					
	<input type="checkbox"/> 3					
	<input type="checkbox"/> 4					
	<input type="checkbox"/> 5					
	<input type="checkbox"/> STANDARD	–	–		Clears all current detail-adjusted settings and switch settings and returns the settings to the standard settings saved in the reference file.	
	SCENE RECALL	Displays the SCENE FILE selection screen.	EXEC	–	Recalls the scene file from the memory of the camcorder or the “Memory Stick”.	
	SCENE STORE	Displays the SCENE FILE selection screen.	EXEC		Stores the scene file in the memory of the camcorder or the “Memory Stick”.	
F.ID	Displays character input mode (up to 16 characters).	Blank		Sets the File ID.	Sc	

### The MAINTENANCE menu

Page	Item	Settings	Default	USER menu	Description	File
WHITE SHADING	WHT SHAD CH SEL	R/G/B	R	–	Selects the channel adjusted by this menu.	A P
	R/G/B WHT H SAW	(–99 to 99)	0		Compensates horizontal Saw white shading.	P
	R/G/B WHT H PARA				Compensates horizontal Parabola white shading.	
	R/G/B WHT V SAW				Compensates vertical Saw white shading.	
	R/G/B WHT V PARA				Compensates vertical Parabola white shading.	
	WHITE SAW/PARA				OFF/ON	

Page	Item	Settings	Default	USER menu	Description	File
BLACK SHADING	BLK SHAD CH SEL	R/G/B	R	–	Selects the channel adjusted by this menu.	A P
	R/G/B BLK H SAW	(–99 to 99)	0		Compensates horizontal Saw black shading.	P
	R/G/B BLK H PARA				Compensates horizontal Parabola black shading.	
	R/G/B BLK V SAW				Compensates vertical Saw black shading.	
	R/G/B BLK V PARA				Compensates vertical Parabola black shading.	
	BLACK SAW/PARA				OFF/ON	
	MASTER BLACK	(–99 to 99)	0		Adjusts the master black level.	A P Sc R St
	MASTER GAIN (TMP)	–3dB/0dB/3dB/ 6dB/9dB/12dB/ 18dB/24dB/ 30dB/36dB	Depends on the switch.		Temporarily adjusts the master gain value.	
BATTERY	<Sony Info>					
	BEFORE END 1	5 to 100% (in 5% steps)	5%	–	When a BP-GL65/GL95 Battery Pack is used, sets the voltage warning level just before the battery ends.	A P
	END 1	0 to 5% (in 1% steps)	0%		When a BP-GL65/GL95 Battery Pack is used, sets the voltage level at which the battery ends and the camcorder stops operation, just before the battery ends.	
	<Sony>					
	BEFORE END 2	11.5 to 17.0V (in 0.1V steps)	11.5V	–	When a BP-L60S Battery Pack is used, sets the voltage warning level just before the battery ends.	A P
	END 2	11.0 to 11.5 V (in 0.1V steps)	11.0V		When a BP-L60S Battery Pack is used, sets the voltage level at which the battery ends and the camcorder stops operation, just before the battery ends.	
	<Others, EXT DC>					
	BEFORE END 3	11.5 to 17.0V (in 0.1V steps)	11.8V	–	When a battery pack other than a BP-GL65/GL95/L60S or an external power connected to the DC IN connector is used, sets the voltage warning level just before the battery ends.	A P
END3	11.0 to 14.0 V (in 0.1V steps)	11.0V		When a battery pack other than a BP-GL65/GL95/L60S or an external power connected to the DC IN connector is used, sets the voltage level at which the battery ends and the camcorder stops operation, just before the battery ends.		

Page	Item	Settings	Default	USER menu	Description	File
AUDIO	AU MODE	FS32K/FS48K	FS48K	Page4	Sets the audio recording level.	A P
	AU HEADROOM	NTSC: -12dB/ -20dB PAL: -12dB/ -18dB	NTSC: -20dB PAL: -18dB	-	Sets the audio reference level.	
	AU FADE	OFF/ON	OFF		Turns the audio fade-in and fade-out functions on or off. (When set to ON, recording is continued during an audio fade-out.)	
	AU SG (1KHz)	OFF/ON	OFF		Sets whether to output a 1 kHz test tone during the Color Bar mode or not.	
	F AUDIO VOL	ENABL/DSABL	ENABL		Sets the validity of the AUDIO LEVEL knob on the front of the camcorder (page 11). (When setting to ENABL, the level of CH-1 is set to the value of AUDIO LEVEL knob on the front of the camcorder multiplied by the AUDIO LEVEL (CH-1/CH-2) control on the side of the camcorder.)	
VTR MODE	REC TALLY BLINK	OFF/ON	ON	-	Turns the tally illumination control on or off in the event of BATTERY BEFORE END/TAPE BEFORE END.	A P
	STBY OFF TIMER	1MIN/3MIN/ 5MIN	1MIN		Sets the time of standby-off interval (if there is no operation for a preset interval time while the recording is stopped, the camcorder goes to standby-off mode automatically).	
	REC FORMAT	DVCAM/DV SP	DVCAM	Page4	Selects the type of video codec.	
	SETUP ADD	OFF/ON	ON	-	See "To use setup add (DSR-400/450WS only)" on page 66.	
PRESET WHT	COLOR TEMP <P>	Displays color temperature (Converted form R/B GAIN).	3200	Page1	Sets the color temperature of preset white balance.	A P R St
	COLOR FINE <P>	(-99 to 99)	0	-	Adjusts the value more precisely when the color temperature adjustment through COLOR TEMP <P> is not satisfactory.	
	R GAIN <P>				Sets R gain of preset white balance.	
	B GAIN <P>				Sets B gain of preset white balance.	
	D5600K <P>	OFF/ON	OFF		Selects whether to electrically apply 5600K filter to preset white balance.	A St
	AWB ENABLE <P>				Turns on and off the function which automatically acquires the preset white balance.	-
DCC ADJUST	DCC FUNCTION SEL	DCC/ADP.K/ FIX	DCC	-	Selects the function assigned to the DCC switch. ADP.K stands for Adaptive Knee and FIX stands for fixed value.	A P Sc
	DCC D RANGE	400% / 450% / 500% / 550% / 600%	600%		Sets the dynamic range when the DCC switch is set to the ON position.	A P
	DCC POINT	(-99 to 99)	0		Adjusts DCC minimum knee point.	
	DCC GAIN				Adjusts gain to DCC detected value.	
	DCC DELAY TIME				Adjusts DCC reaction speed.	

Page	Item	Settings	Default	USER menu	Description	File
AUTO IRIS 2	IRIS WINDOW	1/2/3/4/5/VAR	1	–	Selects the auto iris detection window. VAR is variable.	A P R St
	IRIS WINDOW IND	OFF/ON	OFF		Turns on and off the function which displays a frame marker for the auto iris detection window.	–
	IRIS LEVEL	(–99 to 99)	0		Adjusts level of the auto iris target value.	A P Sc R St
	IRIS APL RATIO				Adjusts mix ratio of auto iris detection peak value and average value.	
	IRIS VAR WIDTH	20 to 465	245		Adjusts width of detection frame when the auto iris detection window is set to VAR.	A P
	IRIS VAR HEIGHT	NTSC: 20 to 120 PAL: 20 to 142	NTSC: 72 PAL: 85		Adjusts height of detection frame when the auto iris detection window is set to VAR.	
	IRIS VAR H POS	–452 to 452	0		Adjusts horizontal position of detection frame when the auto iris detection window is set to VAR.	
	IRIS VAR V POS	NTSC: –101 to 100 PAL: –122 to 122	0		Adjusts vertical position of detection frame when the auto iris detection window is set to VAR.	
	IRIS SPEED	(–99 to 99)	0		Adjusts auto iris speed.	A P Sc R St
	CLIP HIGH LIGHT	OFF/ON	OFF		Turns on and off the function which, during auto iris adjustment, ignores very bright areas by dulling the reaction to high luminescence.	A P
FUNCTION 3	WHT FILTER INH	OFF/ON	OFF	–	Turns on and off the function which inhibits independent white memory for each filter position.	A P
	COLOR BAR SEL	SMPTE/EBU/SNG	NTSC: SMPTE PAL: EBU		Selects color bar type.	
	REC TALLY	UPPER/BOTH	UPPER		Selects whether to light the upper tally indicator only, or both upper and lower tally indicators.	
	USER & ALL ONLY	OFF/ON	OFF		Sets to show only USER menu in the TOP menu.	
	RM COMMON MEMORY				Selects whether or not to share settings for when a remote control unit is connected and when the camcorder is used alone.	
	RM REC START	RM/CAM/PARA	RM		When a remote control unit is connected, selects which REC buttons are enabled (Remote control only, the camcorder only, or both).	
	i.LINK CTL	ALL, REC/P, OFF	REC/P		Sets the control command output from the i.LINK DV OUT connector. See “Settings required for an i.LINK connection” on page 42.	
	i.LINK CTL(END)	OFF/ON	OFF		Selects whether or not to stop the tape on the external equipment via the i.LINK cable when the battery of the camcorder is exhausted.	



Page	Item	Settings	Default	USER menu	Description	File
GENLOCK	GENLOCK	OFF/ON	ON	–	Turns genlock on and off.	A P
	GL H PHASE	(–99 to 99)	0	Page5	Sets genlock horizontal phase.	
	GL SC PHASE				Sets genlock subcarrier phase.	
	GL SC 0/180 SEL	0/180	180			
ND COMP	ND OFFSET ADJUST	OFF/ON	OFF	–	Turns on and off the mode which sets ND (neutral density) filter color compensation values.	–
	CLEAR ND OFFSET	After asking YES/NO, executes the function.	EXEC		Clears ND filter color compensation values.	
AUTO SHADING	AUTO BLK SHADING	–	EXEC	–	Execute the auto black shading function.	–
	RESET BLK SHD	After asking YES/NO, executes the function.			Clears black shading compensation values.	
	MASTER GAIN (TEMP)	–3dB/0dB/3dB/6dB/9dB/12dB/18dB/24dB/30dB/36dB	Depends on switch.			Temporarily sets the master gain value.

### The FILE menu

Page	Item	Settings	Default	USER menu	Description	File	
USER FILE	USER FILE LOAD	Displays the USER FILE selection screen.	EXEC	–	See “Saving and Loading User Files” on page 110.	–	
	USER FILE SAVE						
	F. ID	Displays character input mode (up to 16 character).	–				
	USER PRESET	After asking YES/NO, executes the function.	EXEC				See “Resetting USER menu settings to the standard settings” on page 99.
USER FILE 2	STORE USR PRESET	After asking YES/NO, executes the function.	EXEC	–	Sets the pages registered in the USER menu to the standard setting.	–	
	CLEAR USR PRESET				Clears the standard setting of pages registered in the USER menu.		
	CUSTOMIZE RESET				Returns the pages registered in the USER menu to the factory default state.		
	LOAD CUSTOM DATA	OFF/ON	OFF		Selects whether to include pages registered by the user in user files to be loaded by USER FILE LOAD.		A P
	LOAD OUT OF USER				Selects whether to include pages not registered by the user in user files loaded by USER FILE LOAD.		
	BEFORE FILE PAGE				Selects whether to include data after USER FILE pages in user files to be loaded by USER FILE LOAD.		
	USER LOAD WHITE				Selects whether to include white balance data in user files to be loaded by USER FILE LOAD.		

Page	Item	Settings	Default	USER menu	Description	File
ALL FILE	ALL FILE LOAD	Displays the FILE selection screen.	EXEC	-	Loads ALL file.	-
	ALL FILE SAVE				Saves ALL file.	
	F.ID	Displays character input mode (up to 16 character).	Blank		Names ALL file.	A
	ALL PRESET	After asking YES/NO, executes the function.	EXEC		Returns items in ALL file to preset values.	-
	STORE ALL PRESET				Sets preset values of items in ALL file.	
	CLEAR ALL PRESET				Clears preset values of items in ALL file.	
SCENE FILE	<input type="checkbox"/> 1	-	STANDARD	-	See "Saving and Loading Scene Files" on page 114.	-
	<input type="checkbox"/> 2					
	<input type="checkbox"/> 3					
	<input type="checkbox"/> 4					
	<input type="checkbox"/> 5					
	<input type="checkbox"/> STANDARD	-	-			
	SCENE RECALL	Displays the SCENE FILE selection screen.	EXEC			
	SCENE STORE					
F.ID	Displays character input mode (up to 16 characters).	Blank	Sc			
REFERENCE	REFERENCE STORE	After asking YES/NO, executes the function.	EXEC	-	Saves reference file in internal memory.	-
	REFERENCE CLEAR				Clears reference file.	
	REFERENCE LOAD				Loads reference file.	
	REFERENCE SAVE				Saves reference file to "Memory Stick".	
	F. ID	Displays character input mode (up to 16 characters).	Blank		Names reference file.	R
	SCENE WHITE DATA	OFF/ON	OFF		See "White balance setting data when loading the scene file" on page 115.	A P

Page	Item	Settings	Default	USER menu	Description	File
LENS FILE 1	LENS FILE RECALL	Displays the FILE selection screen.	EXEC	-	Loads lens file.	-
	LENS FILE STORE				Saves lens file.	
	F. ID	Displays character input mode (up to 16 characters).	Blank		Names lens file.	L
	LENS NO OFFSET	After asking YES/NO, executes the function.	EXEC		Clears lens file.	-
	SOURCE	-	MEMORY 1		Displays number of selected lens file.	
	IRIS GAIN	(-99 to 99)	0		Adjusts iris gain value of lens file.	L
LENS FILE 2	LENS M VMOD*	(-99 to 99)	0	-	Sets lens file V SAW shading.	L
	LENS CENTER H*	-48 to 47	0		Compensates horizontal position of lens file center marker.	
	LENS CENTER V*	-15 to 14	0		Compensates vertical position of lens file center marker.	
	LENS R FLARE*	(-99 to 99)	0		Adjusts lens file flare (R).	
	LENS G FLARE*				Adjusts lens file flare (G).	
	LENS B FLARE*				Adjusts lens file flare (B).	
	LENS W-R OFST*				Compensates R value when extender and shrinker used.	
	LENS W-B OFST*				Compensates B value when extender and shrinker used.	
LENS FILE 3	SHADING CH SEL	R/G/B	R	-	Selects the channel adjusted by this menu.	A P
	LENS R/G/B H SAW*	(-99 to 99)	0		Compensates horizontal Saw white shading.	L
	LENS R/G/B H PARA*				Compensates horizontal Parabola white shading.	
	LENS R/G/B V SAW*				Compensates vertical Saw white shading.	
	LENS R/G/B V PARA*				Compensates vertical Parabola white shading.	
MEMORY STICK	M.S. FORMAT	After asking YES/NO, executes the function.	EXEC	-	Format "Memory Stick".	-
	M.S. IN > JUMP TO	OFF/USER/ALL/SCENE/LENS/REFER/USER1	OFF		See "Displaying a File-Related Menu Page When Inserting a "Memory Stick"" on page 118.	A P

\* "EX" is displayed when the extender is on, and "0.8" is displayed when the shrinker is on.

The DIAGNOSIS menu

Page	Item	Settings	Default	USER menu	Description	File
HOURS METER	RESET METER	Displays the RESET METER selection screen.	EXEC	–	Displays the RESET METER selection screen.	–
	DRUM RUNNING	000000H to 999999H	–	–	Display only.	–
	TAPE RUNNING					
	OPERATION					
	THREADING	000000 to 999999				
	DRUM RUNNING–2	000000H to 999999H				
	TAPE RUNNING–2					
OPERATION–2						
THREADING–2	000000 to 999999					
TIME/DATE	CLOCK ADJUST	Displays the TIME ADJUST selection screen.	EXEC	Page 8	See “Setting the date/time of the internal clock” on page 106.	–
	HOUR	00 to 23	Internal clock			
	MIN	00 to 59				
	SEC					
	YEAR	00 to 99				
	MONTH	01 to 12				
	DAY	01 to 31				
DEV STATUS 1	I/O	–	–	–	Display only.	–
	FP1	OK/NG				
	FP2					
	CN					
	FRAM	–				
	AT	OK/NG				
	EEPROM	–				
	DCP1	OK/NG				
	DCP2					
	PA					
	LSI	–				
	PX	OK/NG				
	BCS					
	SCI	–				
	SY	OK/NG				
RM	--/OK/NG					

Page	Item	Settings	Default	USER menu	Description	File
DEV STATUS 2	AUTO CHECK	After asking YES/NO, executes the function.	EXEC	–	See “Using the auto-check function” on page 121.	–
	HUMID TIMER RESET				Resets the humid alarm.	
OPTION BOARD	SDI OUTPUT	–	–	–	Displays status of installed option board.	–
	COMPOSITE VIDEO INPUT					



## Displaying menus

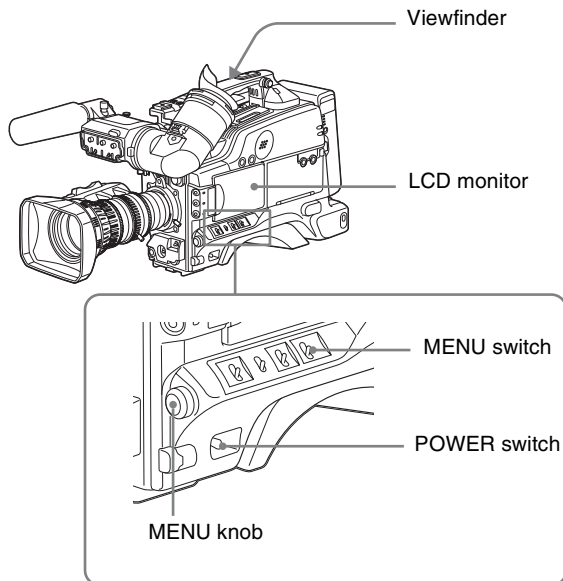

When the camcorder is powered on, flick the MENU switch to the ON position to display the menu on the viewfinder screen and the LCD monitor of the camcorder. If this is the first time the menu has been used after the camcorder has been powered on, the USER menu is displayed. If the menu has been used before, the last accessed page appears.

### When the menu is not displayed on the LCD monitor

Press the DISP SEL button on the lower left of the LCD monitor to select the CHAR display.

### To end menu operations

Flick the MENU switch to OFF.

When the DISPLAY switch on the viewfinder is set to ON or the VF DISP item on the VF DISP 1 page is set to ON, the display indicating the current status of the camcorder appears on the viewfinder.

For details, see “Selecting the display items” on page 99.

### To display the TOP menu

If the menu is not displayed on the screen, press and hold the MENU knob and flick the MENU switch to the ON position.

## Basic menu operations

By pressing and turning the MENU knob, you can set various menu items. In the remainder of this section, the viewfinder screen is generally shown as an example of the menu display, but a similar display also appears on the LCD monitor.

### To select the setting items and values on the menu

Turn the MENU knob to select in the cases explained below.

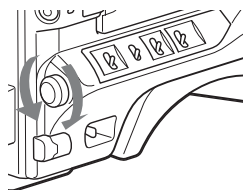

### To scroll pages

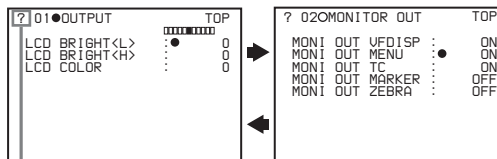

When ? blinks, turn the MENU knob to switch pages.

### To select a menu to set

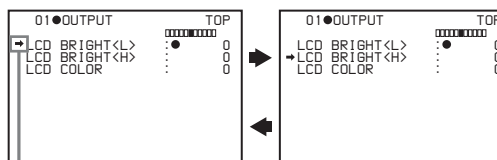

When ➔ appears, turn the MENU knob to move ➔ up and down.

### To change a setting value

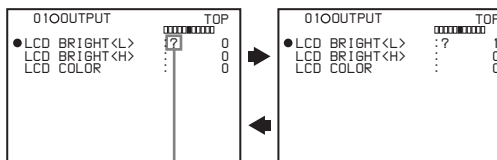

When ? blinks, turn the MENU knob to change the setting (ON/OFF, value, etc.).

## To confirm the setting items and values on the menu

Each time you press the MENU knob, the menu display switches in the following sequence.

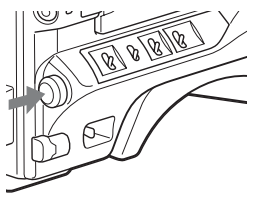

### Example: When using the OPERATION menu

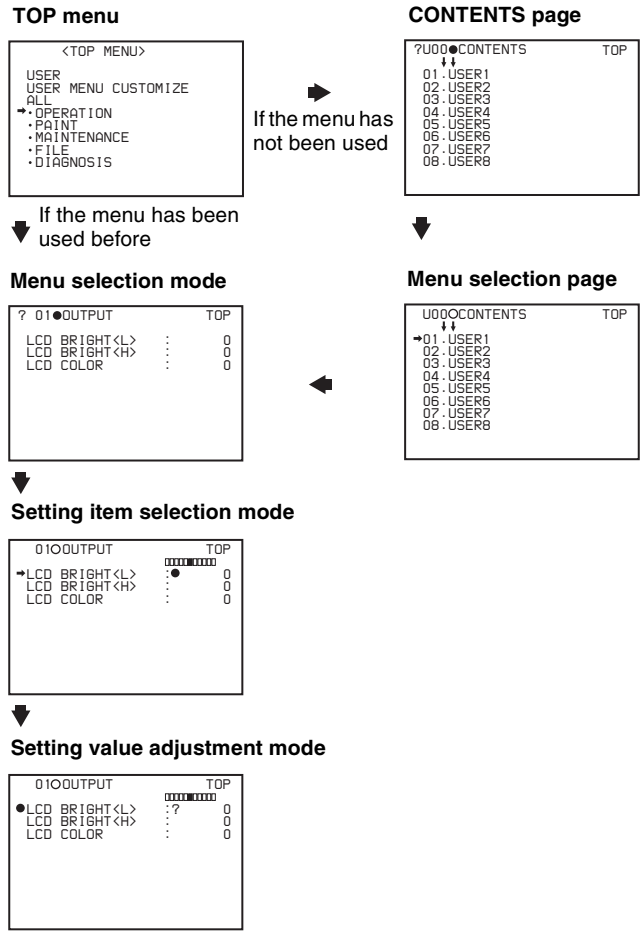

**Note**

If the TOP menu has not been displayed since the camcorder is turned on, TOP does not appear on the upper right in the above screens, and you cannot go to the TOP menu. In this case, follow the procedure in “To display the TOP menu” on page 94.

### To display the TOP menu when another menu is displayed

Move ➡ to TOP displayed at the top right of each page of the menu, and press the MENU knob. Or flick the MENU switch repeatedly to CANCEL until the TOP menu is displayed.

## Using the USER menu (Example of the menu operation)

This section explains menu operations using the USER menu as an example. The operations are the same for the ALL, OPERATION, PAINT, MAINTENANCE, FILE, and DIAGNOSIS menus. For details about how to operate the USER MENU CUSTOMIZE menu, see “Editing the USER menu” on page 96.

Also, if an optional extension boards has not been installed in your camcorder, some items are not displayed.

### 1 Flick the MENU switch to ON.

The USER menu normally appears.

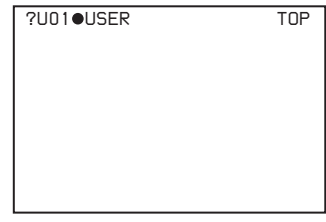

If it does not, turn the MENU knob to move ➡ to USER in the TOP menu, and press the MENU knob. If the USER menu has been used before, the last accessed page appears. In this case, go to step 2. If this is the first time the USER menu has been displayed, the CONTENTS page of the USER menu appears. In this case, follow the procedure below.

### ① Press the MENU knob. Then turn the MENU knob to move ➡ to the desired page number.

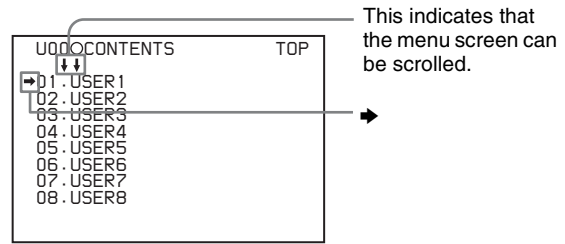

### ② Press the MENU knob again. The page selected in ① is displayed. Go to step 3.

When you set items on the ALL, OPERATION, PAINT, MAINTENANCE, FILE, or DIAGNOSIS menu, move ➡ to the menu that contains the desired item in the TOP menu, and then press the MENU knob.

- 2** Turn the MENU knob until the desired page appears.

?U01●USER 1	TOP
IRIS OVERRIDE :	OFF
DETAIL LEVEL :	0
MASTER BLACK :	0
BLACK GAMMA :	OFF
MASTER BLK GAMMA :	0
COLOR TEMP <P> :	3200

- 3** Press the MENU knob.

➔ and ● appear.

U01●USER 1	TOP
➔ IRIS OVERRIDE :●	OFF
DETAIL LEVEL :	0
MASTER BLACK :	0
BLACK GAMMA :	OFF
MASTER BLK GAMMA :	0
COLOR TEMP <P> :	3200

- 4** Turn the MENU knob to move ➔ to the desired item, and then press the MENU knob.

➔ changes to ●, and ● changes to ?.

- 5** Turn the MENU knob to change the setting.

Depending on the direction of turning the knob, the setting value increases, decreases, switches between ON and OFF, etc.

If you want to cancel a change or return to the standard settings, see the next item “*To cancel setting*” and “*To return to the standard settings*”.

#### To interrupt changing the settings

Flick the MENU switch to OFF.

By flicking the MENU switch to ON again, the values that were displayed when you interrupted the setting operations will reappear so you can continue making settings.

- 6** Press the MENU knob.

● changes to ➔, and ? changes to ●. The selection is set.

- 7** To continue setting other items on the same page, repeat steps from **4** to **6**.

- 8** To end the menu operation, flick the MENU switch to OFF.

The menu disappears from the screen, and the display indicating the current status of the camcorder appears along the top and bottom of the screen.

#### To cancel setting

Before pressing the MENU knob in step **6** of the above procedure, flick the MENU switch to CANCEL.

#### To return to the standard settings

By pressing and holding the MENU knob in step **5** of the above procedure, the settings return to the standard.

#### To move to another page

?U01●USER 1	TOP
IRIS OVERRIDE :	OFF
DETAIL LEVEL :	0
MASTER BLACK :	0
BLACK GAMMA :	OFF
MASTER BLK GAMMA :	0
COLOR TEMP <P> :	3200

Page number

#### When ? appears in front of the page number

Turn the MENU knob to switch pages.

#### When nothing appears in front of the page number

Turn the MENU knob to move ➔ to the page number, and press the MENU knob. Then Turn the MENU knob to switch pages.

### Editing the USER menu

The USER MENU CUSTOMIZE menu allows you to configure a USER menu that consists only of pages and items that you need by adding, deleting or replacing the pages.

#### To add a new page

The USER MENU CUSTOMIZE menu allows you to add a new page to the USER menu.

While the EDIT page contains factory-preset items, the USER 9 EDIT to USER 19 EDIT pages are all blank in their initial state. You can register up to 10 items, including blank lines, on each of these pages.

- 1** Display the TOP menu (*page 94*).

- 2** Turn the MENU knob to move ➔ to USER MENU CUSTOMIZE, then press the MENU knob.

If this is the first time the USER MENU CUSTOMIZE menu has been displayed, the CONTENTS page of the menu appears.



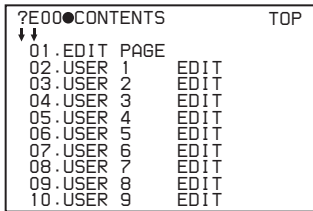

If the USER MENU CUSTOMIZE menu has been used before, the last accessed page appears.

- 3** If the CONTENTS page is displayed, press the MENU knob. Then turn the MENU knob to move  $\blacktriangleright$  to one of USER 1 EDIT to USER 19 EDIT, and press the MENU knob again.

If a different page is displayed, turn the MENU knob until the desired page appears, then press the MENU knob.

Example: When selecting the USER 9 EDIT page

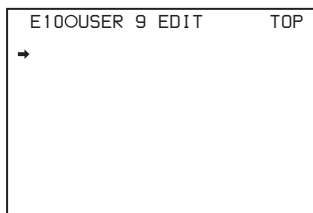

- 4** Press the MENU knob. Then turn the MENU knob to move  $\blacktriangleright$  to the line where you want to add an item, and press the MENU knob again.

The EDIT FUNCTION page appears.

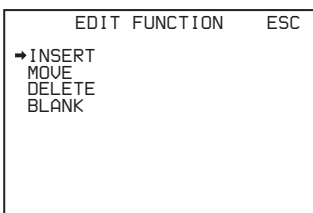

- 5** Press the MENU knob. Then turn the MENU knob to move  $\blacktriangleright$  to INSERT, and press the MENU knob again.

The page for the last added item appears.

- 6** Add the items as below.

- ① Turn the MENU knob until the page that has the desired items appears, then press the MENU knob.
- ② Turn the MENU knob to move  $\blacktriangleright$  to the desired item, then press the MENU knob.

The USER 2 EDIT page appears again, displaying the newly added item.

- 7** Repeat steps **4** to **6** to add the remaining items.

You can add up to 10 items on one page.

### To delete items from a page by using the MENU knob

- 1** Follow steps **1** to **3** of “To add a new page” on page 96.

- 2** Press the MENU knob. Then turn the MENU knob to move  $\blacktriangleright$  to the item that you want to delete, and press and hold the MENU knob again.

The item is deleted.

### To delete items from a page by using the EDIT FUNCTION page

- 1** Follow steps **1** to **3** of “To add a new page” on page 96.

- 2** Press the MENU knob. Then turn the MENU knob to move  $\blacktriangleright$  to the item that you want to delete, and press the MENU knob again.

The EDIT FUNCTION page appears.

- 3** Turn the MENU knob to move  $\blacktriangleright$  to DELETE, and press the MENU knob.

The previously displayed page appears again, and the message “DELETE OK? Yes  $\blacktriangleright$  No” appears at the upper right.

- 4** To delete, turn the MENU knob to move  $\blacktriangleright$  to YES, and then press the MENU knob.

### To replace items on a page

- 1** Follow steps **1** to **3** of “To add a new page” on page 96.

- 2** Press the MENU knob. Then turn the MENU knob to move  $\blacktriangleright$  to the item that you want to replace, and press the MENU knob again.

The EDIT FUNCTION page appears.

- 3** Turn the MENU knob to move  $\blacktriangleright$  to MOVE, then press the MENU knob.

The previously displayed page appears again.

- 4** Turn the MENU knob to move  $\blacktriangleright$  to the position where you want to move the item, then press the MENU knob.

The item selected in step **2** moves to the position that you selected in step **4**.

## To insert a blank line

- 1 Follow steps **1** to **3** of “*To add a new page*” on page 96.
- 2 Press the MENU knob. Then turn the MENU knob to move  $\blacktriangleright$  to the item above which you want to insert a blank line.

The EDIT FUNCTION page appears.

- 3 Turn the MENU knob to move  $\blacktriangleright$  to BLANK, and press the MENU knob.

The previously displayed page appears again, and a blank line is inserted above the specified item.

### Note

You cannot insert a blank line on a page where 10 items have already been registered.

## To add/delete/replace pages

You can add a new page to the USER menu, delete a page from the USER menu, or replace pages, using the EDIT PAGE of the USER MENU CUSTOMIZE menu.

### To add a page

- 1 Display the TOP menu (*page 94*).
- 2 Turn the MENU knob to move  $\blacktriangleright$  to USER MENU CUSTOMIZE, then press the MENU knob.

If this is the first time the USER MENU CUSTOMIZE menu has been displayed, the CONTENTS page appears. If the menu has been used before, the last accessed page appears.

- 3 If the CONTENTS page is displayed, press the MENU knob. Then turn the MENU knob to move  $\blacktriangleright$  to EDIT PAGE, and press the MENU knob again.

If a different page is displayed, turn the MENU knob until the EDIT PAGE screen appears.

The EDIT PAGE appears.

```
?E01●EDIT PAGE      TOP
01 .USER 1
02 .USER 2
03 .USER 3
04 .USER 4
05 .USER 5
06 .USER 6
07 .USER 7
08 .USER 8
●●●END OF PAGE●●●
```

- 4 Press the MENU knob. Then turn the MENU knob to move  $\blacktriangleright$  to where you want to add the page, then press the MENU knob again.

The EDIT FUNCTION page appears.

- 5 Turn the MENU knob to move  $\blacktriangleright$  to INSERT, and press the MENU knob again.

The CONTENTS page appears.

- 6 Turn the MENU knob to move  $\blacktriangleright$  to the desired page, then press the MENU knob again.

The number and name of the page selected in step **6** is added above the item selected in step **4**.

### To cancel adding a page

Before pressing the MENU knob in step **6**, turn the MENU knob to move  $\blacktriangleright$  to ESC at the top right of the screen, then press the MENU knob.

The EDIT PAGE screen appears again.

### To delete a page by using the MENU knob

- 1 Follow steps **1** to **3** of “*To add a page*”.
- 2 Press the MENU knob. Then turn the MENU knob to move  $\blacktriangleright$  to the page that you want to delete, and press and hold the MENU knob.

### To delete a page by using the EDIT FUNCTION page

- 1 Follow steps **1** to **3** of “*To add a page*”.
- 2 Press the MENU knob. Then turn the MENU knob to move  $\blacktriangleright$  to the page that you want to delete, and press the MENU knob again.

The EDIT FUNCTION page appears.

- 3 Turn the MENU knob to move  $\blacktriangleright$  to DELETE, and press the MENU knob.

The previously displayed page appears again, and the message “DELETE OK? YES  $\blacktriangleright$  NO” appears at the upper right.

- 4 Turn the menu knob to move  $\blacktriangleright$  to YES, and press the MENU knob.

### To replace a page

- 1 Follow steps **1** to **3** of “*To add a page*”.
- 2 Press the MENU knob. Then turn the MENU knob to move  $\blacktriangleright$  to the page that you want to move, and press the MENU knob again.

The EDIT FUNCTION page appears.

- 3 Turn the MENU knob to move  $\blacktriangleright$  to MOVE, then press the MENU knob.

The previous screen appears again.

- Turn the MENU knob to move **▶** to the position to where you want to move the page selected in step 2, and press the MENU knob.

The page selected in step 2 is moved to the position selected in step 4.

## Resetting USER menu settings to the standard settings

You can return all settings in the USER menu to the standard settings.

- Display the USER FILE page of the FILE menu.

For details on menu operations, see “Basic menu operations” on page 94.

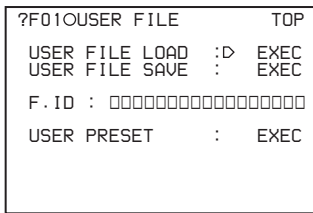

- Press the MENU knob. Then turn the MENU knob to move **▶** to USER PRESET, and press the MENU knob again.

The message “PRESET OK? YES **▶** NO” appears.

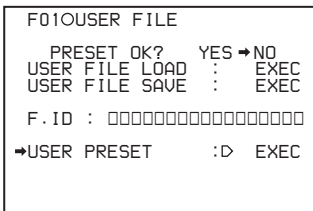

- Turn the MENU knob to move **▶** to YES, and press the MENU knob.

The settings for all items in the USER menu are reset to the standard settings.

# Setting the Status Display on the Viewfinder Screen and the LCD Monitor

This section explains the menu settings for the display of the viewfinder screen. These settings are also used for the display of the LCD monitor in the same way.

## Selecting the display items

To select the items to be displayed on the viewfinder screen and the LCD monitor from the VF DISP 1 and VF DISP 2 pages of the OPERATION menu, turn on or off the indication next to each item.

- Display the VF DISP 1 or VF DISP 2 page of the OPERATION menu.

For details on menu operations, see “Basic menu operations” on page 94.

You can select the following items to be displayed on the screen on the VF DISP 1 and VF DISP 2 pages.

### VF DISP 1 page

Item	Description
VF DISP	Turns on or off the viewfinder screen. <sup>1)</sup>
VF DISP MODE	Selects the display mode. <sup>2)</sup>
DISP EXTENDER	Displays extender.
DISP FILTER	Displays types of the ND filter.
DISP WHITE	Displays selected white balance memory.
DISP GAIN	Displays gain value.
DISP SHUTTER	Displays shutter speed and ECS mode.
DISP AUDIO	Displays audio level.
DISP TAPE	Displays remaining tape capacity.
DISP IRIS	Displays iris opening.

1) The viewfinder screen can be also turned on or off by using the DISPLAY switch of the viewfinder.  
When you turn off the power of the camcorder and then turn it on, the setting of the DISPLAY switch of the viewfinder has a priority over the menu setting. Thus, turning on or off of the viewfinder screen depends on the setting of the DISPLAY switch of the viewfinder.

2) For detailed information on the display mode, see “Display modes and setting change confirmation/adjustment progress messages” on page 100.

## VF DISP 2 page

Item	Description
DISP COLOR TEMP	Displays the color temperature.
DISP BATT REMAIN <sup>1)</sup>	Displays the battery voltage and remaining capacity of an internal battery pack or an external battery connected to the DC IN connector.
DISP DC IN	Displayed when the power is supplied from an external battery connected to the DC IN connector.
DISP 16:9/4:3 ID	Displays the 16:9/4:3 mode indicator.
DISP VTR STATUS	Displays the VTR operating status.
DISP VTR TRIGGER <sup>2)</sup>	Displays the REC TRIGGER switch setting.
DISP TIME CODE	Displays the time code.
DISP REC FORMAT	Displays the recording format.

1) When an Anton Bauer Intelligent Battery System or a BP-GL65/GL95/L60S battery pack is used, the setting of this item determines the display as follows.

INT: The remaining battery capacity is shown as a percentage when there is a change, and when the capacity is low.

AUTO: The remaining battery capacity is shown as a percentage, except that when this is impossible the battery voltage appears.

VOLT: The battery voltage is shown.

2) Displays only when an external VTR is connected to the  (i.LINK) DV OUT connector.

- 2 Select whether the item should appear in the viewfinder screen (the ON setting), or not appear (the OFF setting).

## Display modes and setting change confirmation/adjustment progress messages

You can limit or suppress the messages that give details of setting changes and adjustment progress and results by setting a display mode.

The conditions under which messages are displayed and their correspondence with the display mode are as follows.

## Setting change confirmation/adjustment progress messages and display modes

Y: Message is displayed.

N: Message is not displayed.

Message display condition	Message	Display mode setting		
		1	2	3
When the filter selection has been changed	ND: n (where n = 1, 2, 3, 4)	N	N	Y
When the gain setting has been changed	GAIN: n (where n = -3dB, 0dB, 3dB, 6dB, 9dB, 12dB, 18dB, 24dB, 30dB, 36dB)	N	N	Y
When the setting of the WHITE BAL switch has been changed	WHITE: n (where n = A CH, B CH, PRESET) or ATW: RUN	N	N	Y
When the OUTPUT/DCC switches has been set to DCC ON or OFF	DCC: ON (or OFF)	N	Y	Y
When the shutter speed and mode setting has been changed*	: SS: 1/100 (or 1/125, 1/250, 1/500, 1/1000, 1/2000, ECS, SLS)	N	Y	Y
When the black or white balance has been adjusted	E.g. WHITE: OK	N	Y	Y

\* This is also displayed for about 3 seconds when the SHUTTER switch is set to ON.

## To change the display mode

- 1 Display the VF DISP 1 page of the OPERATION menu.

*For details on menu operations, see "Basic menu operations" on page 94.*

- 2 Set VF DISP MODE to either 1, 2, or 3.

The display mode setting changes.

*For details about the settings of 1 to 3, see the chart above.*

## Setting the marker display

You can switch the display of the center and safety zone markers on or off and select whether the area indicated by the safety zone marker is 80%, 90%, 92%, or 95% of the screen area.

- 1 Display the MARKER 1 page of the OPERATION menu.

*For details on menu operations, see “Basic menu operations” on page 94.*

You can set the following items on the MARKER 1 page.

Item	Description
MARKER	Not to display all markers, set to OFF.
CENTER	To display the center marker, set to ON.
SAFETY ZONE	To display the safety zone, set to ON.
SAFETY AREA	Selects the safety zone range.
ASPECT (DSR-450WS/450WSP only)	To display the aspect marker, set to ON.
ASPECT SELECT (DSR-450WS/450WSP only)	Selects the type of the aspect marker.
ASPECT MASK (4:3) (DSR-450WS/450WSP only)	To make the areas out of the selected aspect marker dimmer, set to ON.
ASPECT MASK LVL (DSR-450WS/450WSP only)	Sets the mask level (1/2, 1/4 or 1/8), when the ASPECT MASK is set to ON.
100% MARKER	To display the effective pixel area, set to ON.

### Note

The items above, except for ASPECT MASK (4:3), are not displayed on the LCD monitor.

- 2 Perform the settings for each item.

*For details about the setting item, see the OPERATION menu list.*

## Setting the viewfinder

Use the VF SETTING page of the OPERATION menu to select items related to the viewfinder.

- 1 Display the VF SETTING page of the OPERATION menu.

*For details on menu operations, see “Basic menu operations” on page 94.*

You can set the following items on the VF SETTING page.

Item	Description
ZEBRA	Turns the zebra display ON or OFF. <sup>1)</sup>
ZEBRA SELECT	Selects ZEBRA 1, ZEBRA 2 or BOTH.
ZEBRA 1 DET LVL	Adjusts the level of the zebra 1 display (20% to 70%). (Factory setting is 70%.)
ZEBRA 1 APT LVL	Adjusts the aperture level of the zebra 1 display (1% to 20%).
ZEBRA 2 DET LVL	Adjusts the level of the zebra 2 display. (Factory setting is 100%.)
VF DETAIL LEVEL	Adjusts the sharpness of the viewfinder (–99 to 0 to 99). <sup>2)</sup> Turns the VF detail function on or off and adjusts the level.
VF ASPECT (DSR-450WS/450WSP only)	Selects the viewfinder aspect ratio (AUTO/16:9). <sup>3)</sup>

1) When you use the viewfinder which is not equipped with the ZEBRA switch, turns the display on or off using this item. When you use the viewfinder with the ZEBRA switch, the most recent operation of the ZEBRA switch and this menu operation is effective.

2) The sharpness setting at the viewfinder does not affect the recorded image.

3) When the VF ASPECT item is set to AUTO, this is linked to the setting of the 16:9/4:3 SELECT item on the FORMAT page. When the VF ASPECT item is set to 16:9, but 4:3 is selected on the FORMAT page, then it is not possible to mix the zebra display and marker display signals on the output signal from the MONITOR OUT connector.

- 2 Perform the settings for each item.

## Recording shot data superimposed on the color bars

In the SHOT DISP page of the OPERATION menu, you can select which shot data is recorded superimposed on the color bars. You can also select which of the shot IDs (1 to 4) set in the SHOT ID page is recorded superimposed on the picture.

- 1 Display the SHOT DISP page of the OPERATION menu.

For details on menu operations, see “Basic menu operations” on page 94.

You can set the following items on the SHOT DISP page.

Item	Description
SHOT DATE	Selects whether or not the shot data is superimposed.
SHOT TIME	Selects whether or not shot time is superimposed.
SHOT MODEL NAME	Selects whether or not the model name is superimposed.
SHOT SERIAL NO	Selects whether or not the serial number is superimposed.
SHOT ID SEL	Selects whether or not the shot ID set on the SHOT ID page is superimposed. To carry out superimposed recording, select the SHOT ID number (1 to 4).
SHOT 16:9 ID	Selects whether or not the 16:9 mode indicator is superimposed (when selecting 16:9 aspect ratio).
SHOT BLINK CHARA	Selects whether or not the blinking character is superimposed.

- 2 Set each item to ON/OFF (whether or not to record the selected item superimposed).

### To carry out superimposed recording

To actually record the items selected for superimposed recording on the SHOT DISP page, set the OUTPUT/DCC switch to BARS, DCC OFF. The items selected for superimposed recording appear on the screen and are recorded superimposed on the color bars.

## Setting the shot ID

On the SHOT ID page of the OPERATION menu, you can set a shot ID of up to 12 alphanumeric characters, spaces, and symbols. When the OUTPUT/DCC switch is set to BARS, DCC OFF, this shot ID is output with the color bar signal. The shot ID comprises ID-1 to ID-4, and you can select the shot ID to be recorded superimposed on the color bars on the SHOT DISP page.

### Note

When the menu is displayed, the shot ID is not displayed even if the color bar signal is output.

- 1 Display the SHOT ID page of the OPERATION menu.

For details on menu operations, see “Basic menu operations” on page 94.

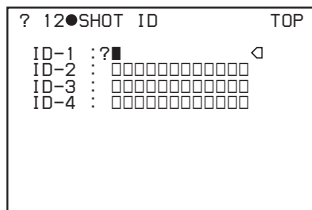

- 2 Press the MENU knob. Then turn the MENU knob to move  $\blacktriangleright$  to the ID (one of ID-1 to ID-4) you want to set, and press the MENU knob again.

$\blacksquare$  appears over the first character position in the string, and characters can now be input.

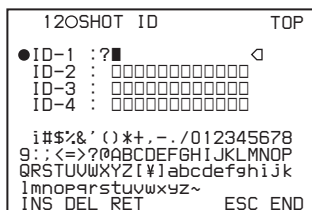

- 3 Enter or change the characters.

When you are entering the shot ID for the first time, go to step ②.

- ① Turn the MENU knob to move  $\blacksquare$  to the character which you want to change, then press the MENU knob.

A character table appears.

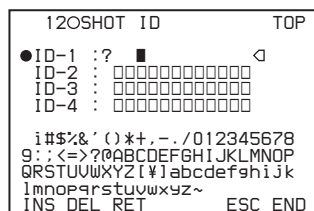



- **REC FORMAT:** Recording format
- **AUDIO MODE:** Audio bit rate
- **DF/NDF** (DSR-400/450WS only): Setting condition of DF/NDF
- **INTERVAL REC:** Condition of Interval Rec
- **VTR TRIGGER MODE:** Trigger mode
- **STANDBY OFF TIMER:** Standby-off timer setting

## To display the status confirmation windows

Flick the MENU switch to STATUS when the menu is not displayed.

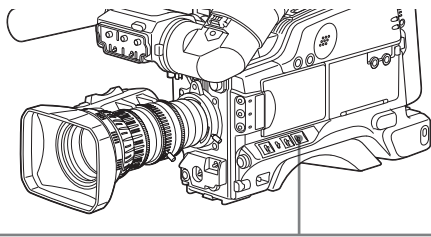

### CANCEL STATUS



Each time you flick the switch to STATUS, the window switches. After 10 seconds, the window disappears automatically.

## To disable display of the status confirmation windows

- 1 Display the SET STATUS page of the OPERATION menu.

For details on menu operations, see “Basic menu operations” on page 94.

You can set the following items on the SET STATUS page.

Item	Description
STATUS CAMERA	Selects whether or not the CAMERA STATUS window is displayed.
STATUS VTR	Selects whether or not the VTR STATUS window is displayed.

- 2 Perform the settings for each item.

# Adjustments and Settings from Menus

## Setting gain values for the GAIN switch positions

You can set the gains corresponding to the L, M, and H positions of the GAIN switch, which switches the gain of the video amplifier.

- 1 Display the GAIN SW page of the OPERATION menu.

For details on menu operations, see “Basic menu operations” on page 94.

You can set the following items on the GAIN SW page.

Item	Description
GAIN LOW	Sets the gain value corresponding to the L position of the GAIN switch.
GAIN MID	Sets the gain value corresponding to the M position of the GAIN switch.
GAIN HIGH	Sets the gain value corresponding to the H position of the GAIN switch.
GAIN TURBO	When assigning TURBO to the ASSIGN switch, sets the gain value corresponding to the ASSIGN switch (page 107).
TURBO SW IND	OFF: When you operate the GAIN switch after pressing the ASSIGN switch that is assigned to TURBO, the gain value is changed according to the ASSIGN switch position. ON: When TURBO GAIN set by pressing the ASSIGN switch that is assigned to TURBO, the gain value is not changed even if you set the GAIN switch, until you press the ASSIGN switch once more.

- 2 Perform the settings for each item corresponding to the switch position (GAIN LOW, GAIN MID, GAIN HIGH, and GAIN TURBO).

Any of -3, 0, 3, 6, 9, 12, 18, 24, 30, or 36 dB can be set in any sequence.

To change the gain corresponding to another switch position, repeat this step.



## Selecting the output signals (DSR-450WS/450WSP only)

When the CBK-SD01 SDI Output Board is installed, you can select the type of video signals from the VIDEO OUT connector on the OUTPUT page. You can select either VBS or SDI.

Please note that only the picture obtained during recording is displayed on a CBK-SD01 SDI Output Board. Playback picture cannot be output.

- 1 Display the OUTPUT page of the OPERATION menu.

*For details on menu operations, see “Basic menu operations” on page 94.*

- 2 Press the MENU knob. Then turn the MENU knob to move  $\blacktriangleright$  to REAR BNC OUT SEL, and press the MENU knob again.

$\blacktriangleright$  changes to  $\bullet$  and  $\bullet$  changes to  $?$ .

- 3 Turn the MENU knob to change the desired setting, and press the MENU knob.

The settings of SDI and VBS are follows.

Setting value	Description
SDI	Outputs the SDI signal. When SDI is selected, connect to the SDI IN connector of the video monitor.
VBS	Outputs the analog composite video signal. When VBS is selected, connect to the VIDEO IN connector of the video monitor. This setting allows you to save the power.

$\bullet$  changes to  $\blacktriangleright$  and  $?$  changes to  $\bullet$ . The selection is set.

## Setting the color temperature manually

You can adjust the value of the white balance manually by setting the color temperature.

- 1 Display the WHITE page of the PAINT menu.

*For details on menu operations, see “Basic menu operations” on page 94.*

You can set the following items on the WHITE page.

Item	Description
COLOR TEMP <A>	Sets the color temperature for the desired value. Adjust the value while looking at the real image because error tends to be bigger for adjustment of high color temperature.
COLOR FINE <A>	Adjusts the value more precisely when the color temperature adjustment through COLOR TEMP is not satisfactory.
R GAIN <A>	Changes only the value of R GAIN.
B GAIN <A>	Changes only the value of B GAIN.
D5600K <A>	Sets the color temperature to approximately 5600K.

The above table shows the adjustment of the white balance of channel A. Items followed by <B> are used to adjust the white balance of channel B.

- 2 Perform the settings for each item.

## Specifying an offset for the auto white balance setting

By setting an offset for the value of auto white balance, you can make the picture warmer or colder.

- 1 Display the OFFSET WHT page of the OPERATION menu.

*For details on menu operations, see “Basic menu operations” on page 94.*

You can set the following items in the OFFSET WHT page.

Item	Description
OFFSET WHITE <A>	Selects if the offset adjusted on this page is added to the white balance for channel A.
WARM-COOL <A>	When OFFSET WHITE <A> is ON, sets the offset for the white balance of channel A, using the color temperature. Adjust the value while looking at the real image because error tends to be bigger for adjustment of high color temperature.
COLOR FINE <A>	Adjusts the value more precisely if the adjustment by WARM-COOL <A> is not satisfactory.
OFFSET WHITE <B>	Selects if the offset adjusted on this page is added to the white balance for channel B.
WARM-COOL <B>	When OFFSET WHITE <B> is ON, sets the offset for the white balance of channel B, using the color temperature. Adjust the value while looking at the real image because error tends to be bigger for adjustment of high color temperature.
COLOR FINE <B>	Adjusts the value more precisely if the adjustment by WARM-COOL <B> is not satisfactory.

- 2 Set the WHITE BAL switch to the channel (A or B) that you want to set.

### Note

If the WHITE BAL switch is not set to A or B, the adjusted value does not affect the video output even though you follow the step below.

- 3 Perform the settings for each item.

If you want to set the another channel, go back to step 2.

## Setting the date/time of the internal clock

You can set or change the date and time of the internal clock. The date and time set here are reflected in the time code.

- 1 Display the TIME/DATE page of the DIAGNOSIS menu.

*For details on menu operations, see “Basic menu operations” on page 94.*

?D02●TIME/DATE		TOP
CLOCK ADJUST	:D	EXEC
HOUR	:	12
MIN	:	55
SEC	:	58
YEAR	:	00
MONTH	:	07
DAY	:	31

- 2 Press the MENU knob. Then turn the MENU knob to move ► to CLOCK ADJUST, and press the MENU knob again.

The TIME ADJUST screen appears.

You can set the following items on the TIME ADJUST screen.

Item	Description
HOUR	Sets the hour value.
MIN	Sets the minutes value.
SEC	Sets the seconds value.
YEAR	Sets the year.
MONTH	Sets the month.
DAY	Sets the day.

- 3 Set the each item to the desired value.
- 4 When you finish settings, turn the MENU knob to move ► to OK, then press the MENU knob.

The internal clock is set with the date and time set in step 3. The TIME/DATE page of the DIAGNOSIS menu appears again. The time set on the TIME ADJUST screen displayed.

### To cancel the setting

Before executing step 4, move ► to ESC and press the MENU knob.

All settings or changes are discarded and the TIME/DATE page appears again.

## Assigning functions to ASSIGN switches

You can assign the desired function to any of the ASSIGN switches.

- 1 Display the FUNCTION 1 page on the OPERATION menu.

For details on menu operations, see “Basic menu operations” on page 94.

You can assign functions to each ASSIGN switch as follows.

Item	Description
ASSIGN SW <1>	Assigns the function to ASSIGN 1 switch.
ASSIGN SW <2>	Assigns the function to ASSIGN 2 switch.
ASSIGN SW <3>	Assigns the function to ASSIGN 3 switch.
ASSIGN SW <4>	Assigns the function to ASSIGN 4 switch.

- 2 Press the MENU knob. Then turn the MENU knob to move  $\blacktriangleright$  to the item corresponding to the switch to which you want to assign the function, and press the MENU knob again.

The corresponding ASSIGN SW (1 to 4) SEL window appears. You can assign the following functions to the ASSIGN switch.

Item	Description
OFF	Assigns no function.
MARKER	Assigns the ON/OFF function to display all markers.*
ATW	Assigns the ON/OFF switch function of ATW.
LENS RET	Assigns the function of recording review.
REC SWITCH	Assigns the VTR start/stop function.
TURBO SWITCH	Assigns the turbo gain value set in TURBO GAIN (page 104).

\* Even when the MARKER item is set to OFF on the MARKER 1 page of the OPERATION menu, the ASSIGN switches allow you to display or not to display all markers.

- 3 Turn the MENU knob to move  $\blacktriangleright$  to the desired function, and press the MENU knob.

The function is assigned, and the FUNCTION 1 page appears again.

## To return to the previous page

Move  $\blacktriangleright$  to ESC at the right top of the window and press the MENU knob.

The FUNCTION 1 page is displayed again.

## Selecting the lens file

You can change the lens file according to the lens in use.

- 1 Display the LENS FILE menu of the OPERATION menu.

For details on menu operations, see “Basic menu operations” on page 94.

The LENS FILE page shows the name and the iris setting value of the lens currently selected.

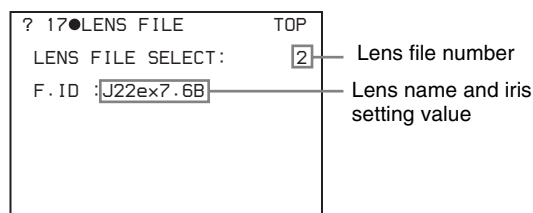

- 2 Set LENS FILE SELECT to the lens file number corresponding to the lens in use.

### If you do not want to use a lens file

Set LENS FILE SELECT to the lens file number 1 (F.ID: No offset).

## Selecting the aspect ratio (DSR-450WS/450WSP only)

You can select the aspect ratio of the video output signal.

- 1 Display the FORMAT menu of the OPERATION menu.

For details on menu operations, see “Basic menu operations” on page 94.

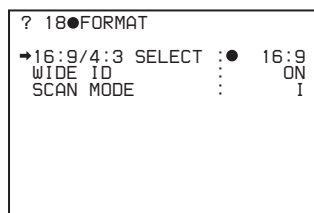

- 2 Set 16:9/4:3 SELECT to the desired aspect ratio.

## To display the aspect ratio of 16:9 or 4:3 on the viewfinder

By setting the DISP 16:9/4:3 ID item to ON on the VF DISP 2 page of the OPERATION menu, “16:9” or “4:3” appears on the viewfinder screen according to the setting of the procedure above.

For details, see “Selecting the display items” on page 99.

## To display “16:9” in color bars

By setting the SHOT 16:9 ID item to ON on the SHOT DISP page of the OPERATION menu, you can record a “16:9” mode indicator superimposed on the color bars.

For details, see “Recording shot data superimposed on the color bars” on page 102.

### NTSC (DSR-450WS)

W	Y	C	G	M	R	B
					16:9	
-I	W	Q				

### PAL (DSR-450WSP)

W	Y	C	G	M	R	B
					16:9	

## Setting the CCD scan mode (DSR-450WS/450WSP only)

The DSR-450WS/450WSP allow you to record in progressive scan mode as well as interlace scan mode. You can select the scan mode from the following modes using the FORMAT page of the OPERATION menu.

- I (interlace scan) mode
- PsF (progressive scan) mode
- 24P mode (DSR-450WS only)

A video signal recorded in progressive mode is converted to a 60i signal and recorded on a tape. Each of the modes has the following features.

### I (interlace scan) mode

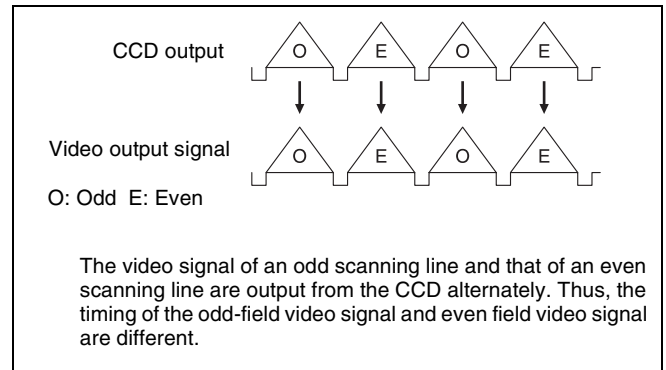

### PsF (progressive scan) mode

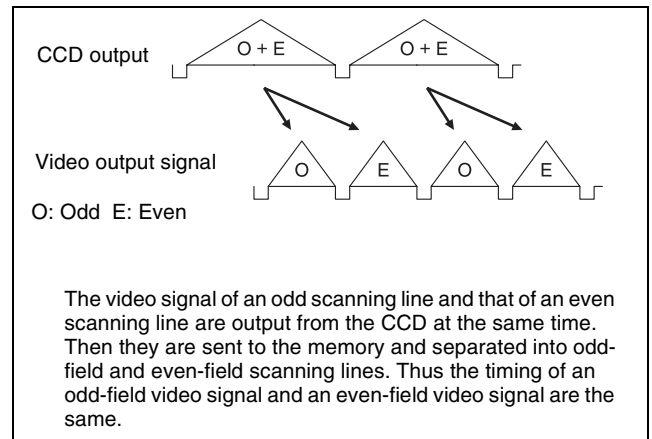

### Pull-down method in 24P mode (DSR-450WS only)

A video signal recorded in 24P mode is pulled down and recorded as a 60i signal and recorded on a tape. You can select either of the following pull-down methods using the FORMAT page of the OPERATION menu.

- 2-3 pulldown
- 2-3-3-2 pulldown

#### Note

When 2-3-3-2 pulldown is selected, only a signal recorded on a tape or output from the i.LINK connector is 2-3-3-2 pulled down. A signal that is output to the viewfinder, LCD monitor, MONITOR OUT connector, or VIDEO OUT connector is 60i (2-3 pulldown).

24P PULLDWN MODE	DF/NDF	Purpose	Notes
2.3 (2-3 pulldown)	DF	To obtain film-like image as interlace signal.	<p>–</p> <ul style="list-style-type: none"> <li>You can start recording at frame 0 or frame 5 of the time code. Therefore, when setting the time code or recording in backspace editing mode, the value of the least significant digit is limited to 0 or 5.</li> <li>There will be noise on the recorded image if you change the operating mode for the internal time code generator using the F-RUN/SET/R-RUN switch under the AUDIO adjustment cover while recording.</li> <li>The video and audio signal and time code output via i.LINK may not be consecutive when recording starts.</li> </ul> <p><b>Notes on 2-3 pulldown</b></p> <ul style="list-style-type: none"> <li>When dropframe time code is input via the TC IN connector, this unit operates in DF mode and synchronization of the pulldown picture and the time code is disabled. This setting will continue in effect until the time code setting (F-RUN/R-RUN or DF/NDF) is changed.</li> <li>When the PRESET/REGEN/CLOCK switch under the AUDIO adjustment cover is set to CLOCK, this unit operates in DF mode. The synchronization of the time code and the pulled down image is disabled.</li> </ul> <p><b>Notes on 2-3-3-2 pulldown</b></p> <ul style="list-style-type: none"> <li>When the PRESET/REGEN/CLOCK switch under the AUDIO adjustment cover is set to CLOCK, the time code is synchronized to the internal clock, and this unit operates in F-RUN and NDF mode.</li> <li>When drop frame time code is input to the TC IN connector, this unit does not operate synchronized to that time code.</li> </ul>
	NDF	To re-convert to 24P with non-linear editing software (NLE). (Select according to your NLE.)	
2.3.3.2 (2-3-3-2 pulldown)	(NDF only)		

### 2-3 pulldown in 24P mode

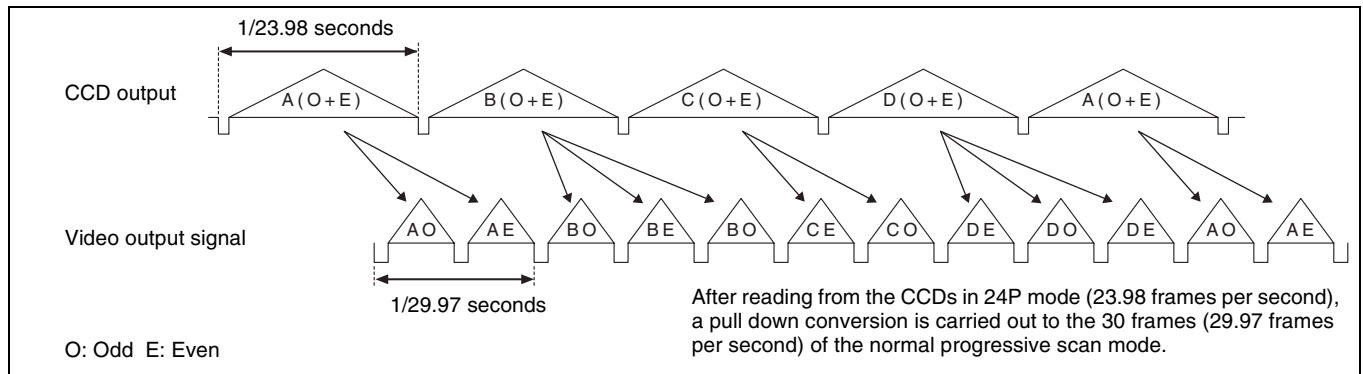

### 2-3-3-2 pulldown in 24P mode

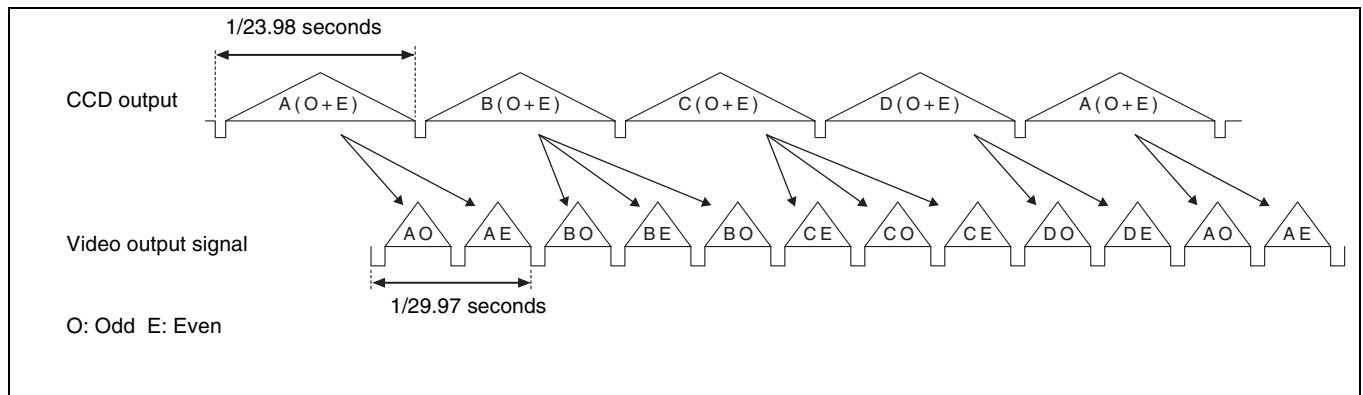

## Saving and Loading User Files

The camcorder is equipped with a “Memory Stick” slot, which enables you to save the settings in the USER menu as a user file onto the “Memory Stick”. You can load these files from the “Memory Stick” for immediate recall of a particular setting configuration. In addition to user file, you can save scene files, lens files, reference files and ALL files in a “Memory Stick”.

When a menu is displayed, you can set up the camcorder so that inserting a “Memory Stick” automatically jumps to the appropriate file-related menu page.

*For details about scene files, see “Saving and Loading Scene Files” on page 114.*

*For details about lens files, reference files and ALL files, refer to “Menu list” on page 76.*

*For details of the function for jumping to the appropriate file-related menu page, see “Displaying a File-Related Menu Page When Inserting a “Memory Stick”” on page 118.*

## Handling the “Memory Stick”

The “Memory Stick” can be inserted to or removed from the camcorder with the power turned on or off.

### “Memory Stick” usable with this camcorder

With this camcorder, you can use “Memory Stick” whose capacity does not exceed 128 MB.

*For details, see “About a “Memory Stick”” on page 124.*

## To insert a “Memory Stick”

- 1 Remove the “Memory Stick” slot cover on the back of the camcorder.

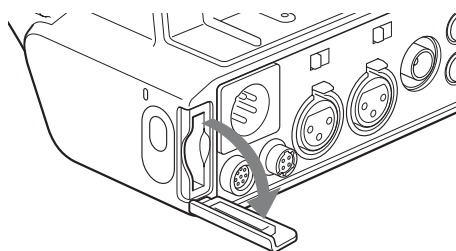

- 2 Insert the “Memory Stick” with its label side facing the “Memory Stick” logo on the camcorder.

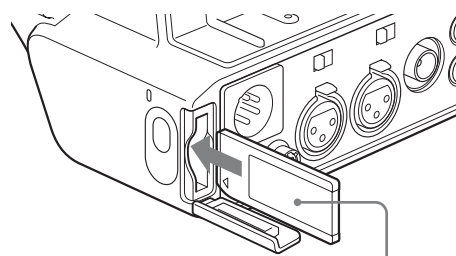

Label side of “Memory Stick”

### Note

If it does not fit into the slot properly or if there is some resistance when you insert it, the “Memory Stick” may be turned around or upside down. Do not force the “Memory Stick” into the slot. Confirm the direction of the notch and arrow on the “Memory Stick” before inserting the “Memory Stick”, and then try inserting it again.

## To remove the “Memory Stick”

- 1 Check that the access indicator is not lit, then gently press in the “Memory Stick” once and release.

The “Memory Stick” pops out.

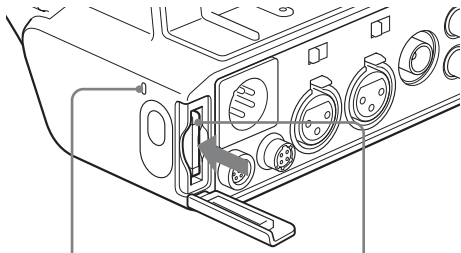

Check that the access indicator is not lit.

Gently press in and release.

- 2 Pull the “Memory Stick” towards you to withdraw it from the slot.

### Note

Do not remove the “Memory Stick” while the access indicator is lit. You may lose data, or damage the “Memory Stick”.

### To protect saved data

To prevent accidental erasure of important setup data, slide the LOCK switch on the “Memory Stick” right to the write protect position.

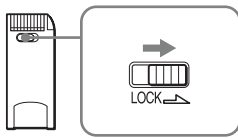

It is now impossible to write or delete data on the “Memory Stick”. If you try to do so, the message “MEMORY STICK LOCKED” appears and the data cannot be overwritten or deleted.

### Notes on using and storing the “Memory Stick”

- Avoid touching the connector of the “Memory Stick” or contacting it with a metal object.
- When attaching a label to the “Memory Stick”, use only the label supplied for the “Memory Stick”.
- Do not drop, bend, or submit the “Memory Stick” to external shock.
- Do not disassemble or modify the “Memory Stick”.
- Avoid getting liquids on the “Memory Stick”.
- Avoid using or storing the “Memory Stick” in a location subject to:
  - extremely high temperature such as the hot inside of a car or the outdoors exposed to a burning sun, or a place near a heater.
  - direct sunlight.
- When storing and carrying the “Memory Stick”, keep it in its original case to ensure protection of important data.
- Do not format the “Memory Stick” using a PC. Format the “Memory Stick” on the MEMORY STICK page of the FILE menu.

## Saving USER menu data (user file) to the “Memory Stick”

You can save USER menu settings held in the camcorder as user files in the “Memory Stick”.

You can save up to 100 user files in the “Memory Stick”. Insert the “Memory Stick” into the “Memory Stick” slot, then proceed as follows.

- 1 Display the USER FILE page of the FILE menu.

For details on menu operations, see “Basic menu operations” on page 94.

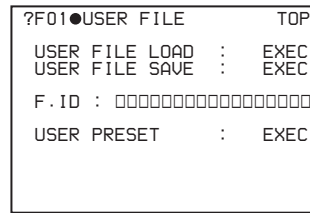

### To set a file ID for the data to be saved

Set the file ID before going to step 2. For details on setting the file ID, see “To set the file ID” on page 112.

- 2 Press the MENU knob. Then turn the MENU knob to move ► to USER FILE SAVE, and press the MENU knob again.

The USER SAVE page appears.

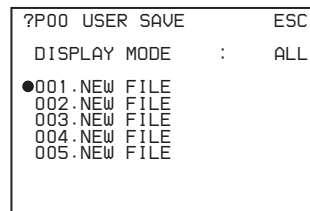

Up to 20 pages, from P00 to P19, can be used to save user files in the “Memory Stick”. Each page can hold up to 5 files.

- 3 Turn the MENU knob until the page which contains the desired file number appears, and press the MENU knob.

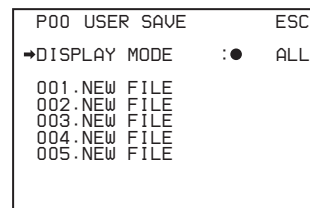

- 4 Turn the MENU knob to move ► to the desired file number, and press the MENU knob.

The message “SAVE OK? YES → NO” appears.

```

P00 USER SAVE      YES→NO  ESC
   SAVE OK?      :      ALL
 DISPLAY MODE      :
→001 .NEW FILE
 002 .NEW FILE
 003 .NEW FILE
 004 .NEW FILE
 005 .NEW FILE
  
```

When a file number is shown as NEW FILE, this means that the file is empty. When data is stored in a file number, the file name appears.

- 5 To carry out the save, turn the MENU knob to move → to YES and press the MENU knob. To cancel, press the MENU knob leaving → pointing to NO.

The access indicator lights. When the saving is completed, the message “COMPLETE” appears and the access indicator goes off.

If no “Memory Stick” has been inserted, the message “NO MEMORY STICK” will appear. Insert a “Memory Stick”.

### If you select a file number where data has already been saved

The message “OVERWRITE OK? YES → NO” appears.

- To stop overwriting, press the MENU knob leaving → pointing to NO.
- To overwrite, turn the MENU knob to move → to YES and press the MENU knob.

You can select the information displayed on each USER SAVE or USER LOAD page.

For details, see “To select the display contents” on page 112.

### About the USER menu settings to be saved in the “Memory Stick”

Settings for items on all pages of the USER menu are saved in the “Memory Stick” as a user file.

### If data cannot be saved

If one of the following error messages appears during or after the save operation, then the data was not saved.

Error message	Cause	Action
NO MEMORY STICK (flashing)	No “Memory Stick” is inserted.	Insert or reinsert the “Memory Stick”.
MEMORY STICK LOCKED	The LOCK switch on the “Memory Stick” is set to the write protect position.	Set the LOCK switch to the write enable position.
MEMORY STICK ERROR (flashing)	Circuit or “Memory Stick” fault.	Check the circuitry, or replace the “Memory Stick”.

## To set the file ID

Before data is saved to a “Memory Stick”, it is useful to set a file ID for the “Memory Stick” to identify it.

When data is saved to a “Memory Stick”, the file ID is saved to the “Memory Stick” together with the data.

### Note

Set the file ID before saving data in the “Memory Stick”. Otherwise, the file ID is not saved with the other data.

- 1 Display the USER FILE page of the FILE menu.  
*For details on menu operations, see “Basic menu operations” on page 94.*
- 2 Press the MENU knob. Then turn the MENU knob to move → to F. ID, and then press the MENU knob again.

A character table appears.

```

F010USER FILE      TOP
USER FILE LOAD    : EXEC
USER FILE SAVE    : EXEC
●F.ID :?■          ◁
$%&'()*+,-./0123456789:
;<=>?@ABCDEFGHIJKLMNPOQR
STUUVWXYZ[\]_
INS DEL RET      ESC END
  
```

- 3 Follow steps 3 and 4 described in “Setting the shot ID” on page 102 to enter characters.
- 4 When you finish entering the file ID, turn the MENU knob to move ■ to END, then press the MENU knob.

The entered file ID is now displayed.

```

130USER FILE      TOP
→USER FILE LOAD   :D EXEC
USER FILE SAVE    :D EXEC
F.ID : ID-001
USER PRESET      : EXEC
  
```

File ID that has been set appears.

After setting the file ID, carry out the procedure from step 2 in “Saving USER menu data (user file) to the “Memory Stick”” on page 111.

The set file ID is saved in the “Memory Stick” with the data.

## To select the display contents

You can select the contents of the file to be displayed on the USER FILE SAVE page and USER FILE LOAD page



(P00 to P19), that are the pages to save and call up the data to and from “Memory Stick”.

- 1 Display the USER FILE LOAD page or the USER FILE SAVE page of the USER FILE menu.

*For details on menu operations, see “Basic menu operations” on page 94.*

- 2 Press the MENU knob. Then turn the MENU knob to move  $\blacktriangleright$  to DISPLAY MODE, and press the MENU knob again.

$\blacktriangleright$  changes to  $\bullet$  and  $\bullet$  changes to  $?$ .

- 3 Turn the MENU knob until the desired type of the display contents (see the following table) appears, then press the MENU knob.

Display type	Description
ALL	File ID (10 characters) and date (month/day/year)
F.ID	File ID (16 characters)
DATE	Saved date (year/month/day/hours/minutes/seconds)
MODEL	Information on the model

$\bullet$  changes to  $\blacktriangleright$  and  $?$  changes to  $\bullet$ . The selection is set.

## Loading saved data from a “Memory Stick”

### Note

The data loaded from the “Memory Stick” overwrites the data saved in the camcorder.

- 1 Display the USER FILE page of the FILE menu.

*For details on menu operations, see “Basic menu operations” on page 94.*

- 2 Press the MENU knob. Then turn the MENU knob to move  $\blacktriangleright$  to USER FILE LOAD, and press the MENU knob again.

The P00 USER LOAD page appears.

?P00●USER LOAD	ESC
DISPLAY MODE :	ALL
001 .USER1	JAN/01/04
002 .USER2	JAN/15/04
003 .NO FILE	
004 .USER4	FEB/05/04
005 .USER5	FEB/20/04

- 3 Turn the MENU knob until the page which contains the desired file appears.

- 4 Press the MENU knob. Then turn the MENU knob to move  $\blacktriangleright$  to the desired file number to be loaded, and press the MENU knob again.

The message “LOAD OK? YES  $\blacktriangleright$  NO” appears.

P00USER LOAD	YES	NO	ESC
LOAD OK?	YES	$\blacktriangleright$ NO	
DISPLAY MODE :			ALL
001 .USER1			JAN/01/04
$\blacktriangleright$ 002 .USER2			JAN/15/04
003 .NO FILE			
004 .USER4			FEB/05/04
005 .USER5			FEB/20/04

- 5 To carry out the load, turn the MENU knob to move  $\blacktriangleright$  to YES and press the MENU knob.

To cancel, press the MENU knob leaving  $\blacktriangleright$  pointing to NO.

The access indicator lights.

When the load is completed, the message “COMPLETE” appears and the access indicator goes off.

The USER FILE page appears again.

### If data cannot be loaded

If one of the following error messages appears during or after the load operation, then the data was not loaded.

Error message	Cause	Action
NO MEMORY STICK (flashing)	No “Memory Stick” is inserted.	Insert or reinsert the “Memory Stick”.
MEMORY STICK ERROR (flashing)	Circuit or “Memory Stick” fault.	Recheck, and consult your Sony representative.
FILE ERROR (flashing)	The “Memory Stick” contains data that cannot be loaded into this camcorder.	You cannot load data saved from another camcorder.

# Saving and Loading Scene Files

You can save various settings for shooting a particular scene as a scene file. Loading the scene file, you can quickly recreate setup conditions suitable for the scene. You can save up to five scene files in the camcorder memory and up to 100 scene files in a “Memory Stick”. You can also load data from the “Memory Stick” into the camcorder memory and vice versa.

## Data that can be saved in a scene file

You can save the following data in a scene file:

- Values adjusted using the PAINT menu
- Shutter speed settings made in the standard mode and ECS mode
- The white balance data included in a scene file depends on the SCENE WHITE DATA setting on the REFERENCE page of the FILE menu.

For details of the PAINT menu, refer to “The PAINT menu” on page 81.

For details of white balance data, see “White balance setting data saved in the scene file” on page 115.

## Saving a scene file

To save a scene file in the “Memory Stick”, insert the “Memory Stick” into the “Memory Stick” slot before starting the operation.

- 1 Display the SCENE FILE page of the FILE menu.

For details on menu operation, see “Basic menu operations” on page 94.

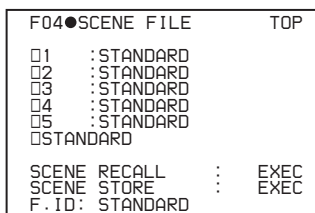

### To set a file ID for the data to be saved

Set the file ID before going to step 2.

For details on setting the file ID, see “To set the file ID” on page 112.

- 2 Press the MENU knob. Then turn the MENU knob to move  $\blacktriangleright$  to SCENE STORE, and press the MENU knob again.

The SCENE STORE page appears.

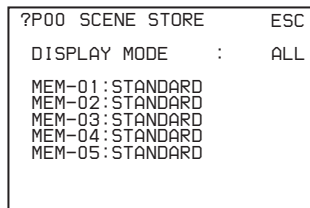

- 3 Press the MENU knob. Then turn the MENU knob to move  $\blacktriangleright$  to the desired file number, and press the MENU knob again.

The file to be saved is selected.

### When no “Memory Stick” is inserted

Press the MENU knob. Then turn the MENU knob to move  $\blacktriangleright$  to the desired memory number, and press the MENU knob again.

When the save is completed, the SCENE FILE page appears again.

### When you select a file number where data has already been saved

The message “OVERWRITE OK? YES  $\blacktriangleright$  NO” appears.

- To stop overwriting, press the MENU knob leaving  $\blacktriangleright$  positioning to NO.
- To overwrite, turn the MENU knob to move  $\blacktriangleright$  to YES and press the MENU knob.

### When a “Memory Stick” is inserted

You can use up to 20 pages, from P01 to P20, to save scene files in the “Memory Stick”. Each page can hold up to 5 files.

- ① Turn the MENU knob until the page which contains the desired file appears, then press the MENU knob.

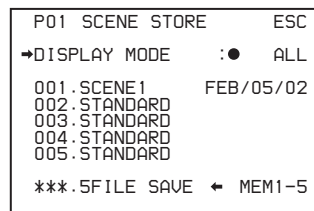

- ② Turn the MENU knob to move  $\blacktriangleright$  to the desired file number, and press the MENU knob. The message “STORE OK? YES  $\blacktriangleright$  NO” appears.

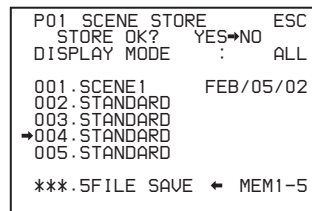

- To carry out the storing, turn the MENU knob to move  $\blacktriangleright$  to YES and press the MENU knob. To cancel, press the MENU knob leaving  $\blacktriangleright$  pointing to NO.

You can select the contents of the user file to be displayed on each page of SCENE STORE and SCENE RECALL.

For details, see “To select the display contents” on page 112.

## White balance setting data saved in the scene file

The white balance setting data saved in the scene file refers to the value of white balance during saving, that is, when the WHITE BAL switch is set to A, the adjusted values in memory A are saved in the scene file, and when the WHITE BAL switch is set to PRST, the preset value is saved.

## White balance setting data when loading the scene file

The method for loading the white balance setting data when loading the scene file differs depending on the setting of the SCENE WHITE DATA item on the REFERENCE page.

```

F050REFERENCE
REFERENCE STORE : EXEC
REFERENCE CLEAR : EXEC

REFERENCE LOAD : EXEC
REFERENCE SAVE : EXEC
F.ID : 00000000000000000000
→SCENE WHITE DATA: ● OFF
  
```

### When SCENE WHITE DATA is set to ON

The white balance setting data saved in the scene file is loaded. (However it is not loaded when the WHITE BAL switch on the camcorder is set to PRST.)

### When SCENE WHITE DATA is set to OFF

The white balance setting data is not loaded.

## To save scene files from the camcorder memory to the “Memory Stick”

You can save five scene files from the camcorder to the “Memory Stick” in a single operation.

- Display the SCENE FILE page of the FILE menu.

For details on menu operations, see “Basic menu operations” on page 94.

- Press the MENU knob. Then turn the MENU knob to move  $\blacktriangleright$  to SCENE STORE, then press the MENU knob again.

- Turn the MENU knob until the desired SCENE STORE page appears, then press the MENU knob.

```

P01 SCENE STORE ESC
→DISPLAY MODE : ● ALL
001 . SCENE1 FEB/05/02
002 . SCENE2 FEB/06/02
003 . NO FILE
004 . SCENE4 FEB/08/02
005 . SCENE5 FEB/08/02
***.5FILE SAVE ← MEM1-5
  
```

- Turn the MENU knob to move  $\blacktriangleright$  to 5FILE SAVE  $\blacktriangleleft$  MEM1-5, and press the MENU knob.

The message “STORE OK? YES  $\blacktriangleright$  NO” appears.

```

P01 SCENE STORE ESC
STORE OK? YES→NO
DISPLAY MODE : ALL

001 . SCENE1
002 . SCENE2
003 . NO FILE
004 . SCENE4
005 . SCENE5
→***.5FILE SAVE ← MEM1-5
  
```

- To carry out the save, turn the MENU knob to move  $\blacktriangleright$  to YES and press the MENU knob. To cancel, press the MENU knob leaving  $\blacktriangleright$  pointing to NO.

When the save is completed, the message “COMPLETE” appears.

### Note

If files have been saved in the page selected in step 3, those files are replaced with files loaded from the camcorder memory. For example, files from 001 to 005 are replaced on the above procedure.

## To set the file ID

Before the data is saved as a scene file, it is useful to set a file ID to identify it. The set file ID is saved together with the data.

- Display the SCENE FILE page of the FILE menu.

For details on menu operations, see “Basic menu operations” on page 94.

- Press the MENU knob. Then turn the MENU knob to move  $\blacktriangleright$  to F. ID, and press the MENU knob again.

A character table appears.

```

F040SCENE FILE TOP
!#$%&'()*+,-./012345678
9:;<=>?@ABCDEFGHIJKLMN
OPQRSTUVWXYZ[ ]abcde fghij
klmnopqrstuvwxyz~
INS DEL RET ESC END
[STANDARD

SCENE RECALL : EXEC
SCENE STORE : EXEC
●F.ID : [STANDARD]
  
```

- Press the MENU knob. Then turn the MENU knob until **■** moves to the character position that you want to select, then press the MENU knob.

**Example: When entering the letter “+”**

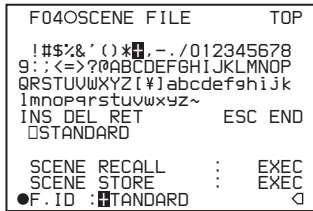

- Repeat step 3 for each of the remaining characters.

#### Note

Set the file ID before saving the scene file in the “Memory Stick” or the camcorder memory. Otherwise, the file ID is not saved with the other data.

- When the input is complete, turn the MENU knob to move **■** over END, then press the MENU knob.

The file ID is set, and the SCENE FILE page appears again.

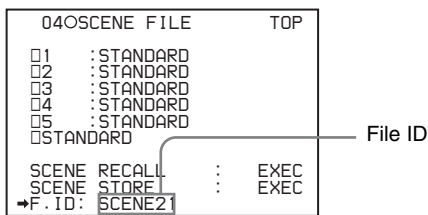

Carry out the procedure from step 2 in “Saving a scene file” on page 114. The set file ID is saved together with the data.

### To select the display contents

You can select the items of file information to be displayed on the SCENE STORE pages (P01 to P20) or the SCENE RECALL pages (P01 to P20) used for saving data to or loading data from a “Memory Stick”.

For details to select the item, “To select the display contents” on page 112.

## Loading scene files

- Display the SCENE FILE page of the FILE menu.  
*For details on menu operations, see “Basic menu operations” on page 94.*
- To load the scene file stored in the camcorder, press the MENU knob. Then turn the MENU knob to move

► to the desired file number, and press the MENU knob again.

on the left of the file number changes to . The camcorder is set up according to the loaded scene file.

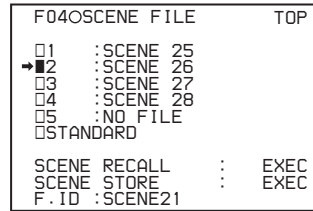

### To cancel the selected scene file

Turn the MENU knob to move ► to **■**, and press the MENU knob. **■** changes to . The camcorder returns to the settings before selecting this scene file.

### To load a scene file saved in the “Memory Stick”

- Turn the MENU knob to move ► to SCENE RECALL, and press the MENU knob.

The SCENE RECALL page appears.

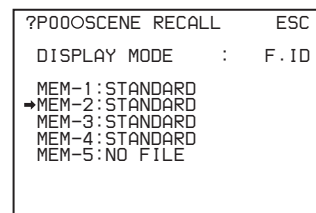

- Turn the MENU knob until the page which contains the desired file appears.
- Press the MENU knob. Then turn the MENU knob to move ► to the desired file number, and press the MENU knob again.

The message “RECALL OK? YES ► NO” appears.

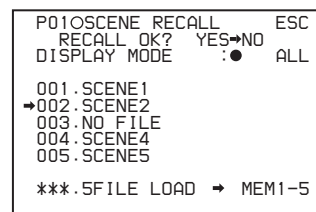

- To carry out the recall, turn the MENU knob to move ► to YES and press the MENU knob. To cancel, press the MENU knob leaving ► pointing to NO.

When the loading is completed, the message “COMPLETE” appears. The camcorder is set up

according to the loaded scene file. If no file is present with a particular file number, this is shown as “NO FILE”.

## To load scene files from a “Memory Stick” into the camcorder memory

You can load up to five scene files stored in the “Memory Stick” into the camcorder memory in a single operation.

- 1 Display the SCENE FILE page of the FILE menu.

*For details on menu operations, see “Basic menu operations” on page 94.*

- 2 Press the MENU knob. Then turn the MENU knob to move  $\blacktriangleright$  to SCENE RECALL, and press the MENU knob again.

The SCENE RECALL page appears.

- 3 Turn the MENU knob until the SCENE RECALL page which contains the desired scene files appears.

- 4 Press the MENU knob. Then turn the MENU knob to move  $\blacktriangleright$  to 5FILE LOAD  $\blacktriangleright$  MEM 1-5, and press the MENU knob.

The message “RECALL OK? YES  $\blacktriangleright$  NO” appears.

```

P01 SCENE RECALL      ESC
RECALL OK?  YES $\blacktriangleright$ NO
DISPLAY MODE      :  ALL

001 . SCENE1
002 . SCENE2
003 . NO FILE
004 . SCENE4
005 . SCENES

 $\blacktriangleright$ *** . 5FILE LOAD  $\blacktriangleright$  MEM1-5
  
```

- 5 To carry out the recall, turn the MENU knob to move  $\blacktriangleright$  YES and press the MENU knob. To cancel, press the MENU knob leaving  $\blacktriangleright$  pointing to NO.

When loading is complete, the message “COMPLETE” appears and the access indicator goes off.

### Notes

- The scene files loaded from the “Memory Stick” overwrite data saved in the camcorder memory.
- To load the scene file saved in the camcorder memory when the “Memory Stick” is inserted, return to the P00 SCENE RECALL page and load the desired scene file in the camcorder memory.
- When there is no file to be loaded (shown as “NO FILE”), an existing file of the same number is unaffected. In the example shown in step 4, MEM(3) is not overwritten.

## Resetting the settings of the camcorder to the standard settings

You can reset the settings of the camcorder to the settings saved in the reference file (standard settings).

*For the items to be saved in the reference file, see page 75.*

- 1 Display the SCENE FILE page of the FILE menu.

*For details on menu operations, see “Basic menu operations” on page 94.*

- 2 Press the MENU knob. Then turn the MENU knob to move  $\blacktriangleright$  to STANDARD, and press the MENU knob again.

```

F040SCENE FILE      TOP
□1  : SCENE 25
□2  : SCENE 26
□3  : SCENE 27
□4  : SCENE 28
□5  : NO FILE
 $\blacktriangleright$ ■ STANDARD

SCENE RECALL      :D  EXEC
SCENE STORE       :   EXEC
F . ID : SCENE21
  
```

displayed on the left of STANDARD changes to . When  changes to  once again, the settings of the camcorder are reset to the settings saved in the reference file.

If you press the MENU knob again while  is displayed, the operation is cancelled and the camcorder returns to the settings before STANDARD was selected.

# Displaying a File-Related Menu Page When Inserting a “Memory Stick”

A “Memory Stick” enables you to save user files, scene files, lens files, reference files and ALL files. The camcorder menu system allows you to make a setting so that when a “Memory Stick” holding these files is inserted while in menu operating mode, a menu page relating to the desired file is automatically displayed on the screen. Thus you can proceed to file operation quickly. This is very convenient especially when you manage data files using “Memory Stick”s.

- 1 Display the MEMORY STICK page of the FILE menu.

*For details on menu operations, see “Basic menu operations” on page 94.*

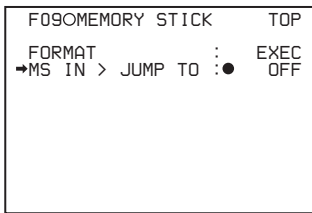

- 2 Press the MENU knob. Then turn the MENU knob to move ▶ to MS IN > JUMP TO, and press the MENU knob again.

▶ on the left of MS IN > JUMP TO changes to ● and ● on the left of setting value changes to ?.

- 3 Turn the MENU knob to select the desired setting (target FILE menu page).

You can select the setting in the chart below.

Setting	Description
OFF	Disables this function. The page does not switch even when “Memory Stick” is inserted.
USER	Displays the USER FILE page.
ALL	Displays the ALL FILE page.
SCENE	Displays the SCENE FILE page.
LENS	Displays the LENS FILE 1 page.
REFER	Displays the REFERENCE page.
USER 1	Displays the USER 1 page.

- 4 Press the MENU knob.

● changes to ▶, and ? changes to ●. The selection is set.

### Note

In the following cases, displaying the target page is impossible even when the “Memory Stick” is inserted.

- When the power is turned on after you insert a “Memory Stick”
- When OFF is selected for the MS IN > JUMP TO item
- When any of the following menu pages is already displayed
  - A file-related page such as the USER FILE page of the FILE menu
  - MEMORY STICK, ALL FILE, SCENE FILE, LENS FILE, or REFERENCE FILE page

---

## Important Notes on Operation

### Use and Storage

#### Do not subject the unit to severe shocks

The internal mechanism may be damaged or the body warped.

#### Do not cover the unit while operating

Putting a cloth, for example, over the unit can cause excessive internal heat build-up.

#### After use

Always turn off the power.

#### Before storing the camcorder for a long period

Remove the battery pack.

#### Shipping

- Remove the cassette before transporting the unit.
- If sending the unit by truck, ship, air or other transportation service, pack it in the shipping carton of the unit.

#### Care of the unit

Remove dust and dirt from the surfaces of the lenses or optical filters using a blower.

If the body of the unit is dirty, clean it with a soft, dry cloth. In extreme cases, use a cloth steeped in a little neutral detergent, then wipe dry. Do not use organic solvents such as alcohol or thinners, as these may cause discoloration or other damage to the finish of the unit.

#### In the event of operating problems

If you should experience problems with the unit, contact your Sony dealer.

#### Use and storage locations

Store in a level, ventilated place. Avoid using or storing the unit in the following places.

- In excessive heat or cold (operating temperature range: 0°C to 40°C (32°F to 104°F))  
Remember that in summer in warm climates the temperature inside a car with the windows closed can easily exceed 50°C (122°F).
- In damp or dusty locations
- Locations where the unit may be exposed to rain
- Locations subject to violent vibration
- Near strong magnetic fields
- Close to radio or TV transmitters producing strong electromagnetic fields.
- In direct sunlight or close to heaters for extended periods

#### To prevent electromagnetic interference from portable communications devices

The use of portable telephones and other communications devices near this unit can result in malfunctions and interference with audio and video signals.

It is recommended that the portable communications devices near this unit be powered off.

#### Note on laser beams

Laser beams may damage the CCDs.

If you shoot a scene that includes a laser beam, be careful not to let the laser beam be directed into the lens of the camera.

#### Use at a high temperature

If the unit is used at a high temperature, white flecks may appear on the screen.

#### Fitting the zoom lens

It is important to fit the lens correctly, as otherwise damage may result. Be sure to refer to the section “*Mounting the lens*” on page 29.

#### Viewfinder

- Do not leave the unit with the eyepiece pointing directly at the sun.  
The eyepiece lens can concentrate the sun’s rays and melt the interior of the viewfinder.
- Do not use the viewfinder close to strong magnetic fields. This can cause picture distortion.

## About the LCD panels

LCD panels are manufactured with extremely high-precision technology that yields effective pixel rates of 99.99% or higher. However, very rarely, one or more pixels may be permanently dark or permanently lit in white, red, blue, or green.

This phenomenon is not a malfunction. Such pixels have no effect on the recorded data, and the unit may be used with confidence even if they are present.

---

## Phenomena specific to CCD image sensors

The following phenomena that may appear in images are specific to CCD (Charge Coupled Device) image sensors. They do not indicate malfunctions.

### White flecks

Although the CCD image sensors are produced with high-precision technologies, fine white flecks may be generated on the screen in rare cases, caused by cosmic rays, etc. This is related to the principle of CCD image sensors and is not a malfunction.

The white flecks especially tend to be seen in the following cases:

- when operating at a high environmental temperature
- when you have raised the master gain (sensitivity)
- when operating in Slow-Shutter mode

This problem may be alleviated by automatic black balance adjustment (*see page 51*).

### Vertical smear

When an extremely bright object, such as a strong spotlight or flashlight, is being shot, vertical tails may be produced on the screen, or the image may be distorted.

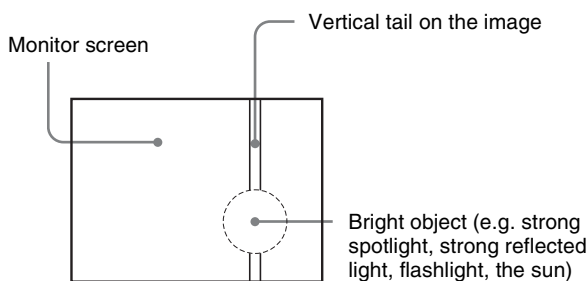

### Aliasing

When fine patterns, stripes, or lines are shot, they may appear jagged or flicker.

### Condensation

If you move the camcorder from a very cold place to a warm place, or use it in a damp location, condensation may

form on the drum. Then, if the camcorder is operated in this state, recording and playback may not be performed properly.

Do the following to prevent this from happening.

- When you move or operate the camcorder in an environment where condensation may form, be sure to insert a cassette in advance and close the cassette compartment lid.
- Whenever you turn on the power, check that the HUMID indicator does not appear on the color LCD. If it appears, wait until it disappears before inserting a cassette.



# Maintenance

## Cleaning the video heads

Always use the special-purpose Sony DVM-12CLD Cleaning Cassette for cleaning the audio and video heads. Follow the instructions with the cleaning cassette carefully, as inappropriate use of the cleaning cassette can damage the heads.

### Note

When the DVM-12CLD is inserted in the camcorder, only STOP, PLAY, REW and EJECT buttons function.

## Replacing the video heads

If cleaning the video heads fails to restore picture quality, the heads may be due for replacement.

Keep a check of the hours of head drum operation: with normal use, the heads should need replacing **after about 2,000 hours of use**.

When the heads need replacement, contact your Sony dealer.

*Check the hours of head drum operation in the DRUM RUNNING item on the HOURS METER page of the DIAGNOSIS menu.*

## Replacing other parts

For replacement of all parts other than the video heads, contact your Sony dealer.

## Using the auto-check function

An internal check can be performed automatically using the auto-check function of the camcorder. Meanwhile, a one minute test recording and playback are also performed. Before shooting, it is desirable to perform this auto-check to check for problems in the VTR's internal operations based on the results of the internal check displayed on the LCD monitor and on the quality of the video and audio recordings.

### Preparations for testing

Make preparations as shown below.

- Connect a monitor to the MONITOR OUT connector (page 17)
- Connect an earphone or headphones to the EARPHONE connector (page 14)
- Prepare a cassette for test recording (page 48)

## To perform the auto-check

- 1 Display the DEV STATUS 2 page of the DIAGNOSIS menu.

*For details on menu operations, see "Basic menu operations" on page 94.*

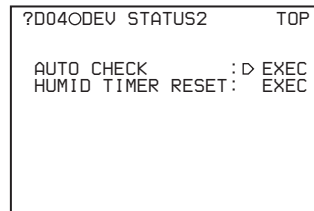

- 2 Press the MENU knob. Then turn the MENU knob to move → to AUTO CHECK, and press the MENU knob again.

The message "EXECUTE OK? YES → NO" appears.

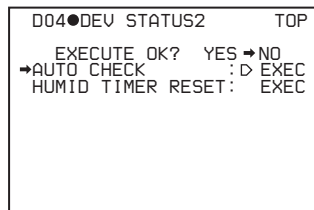

- 3 Turn the MENU knob to move → to YES, and press the MENU knob.

The message "AUTO CHECK EXECUTING" appears on the viewfinder, and then the LCD monitor changes to the AUTO CHECK display. Follow the instructions that appear on the LCD monitor.

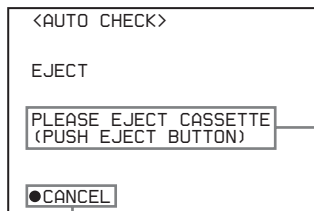

If there is a cassette in the camcorder, follow the instructions and eject the cassette.

When "CANCEL" is displayed, press the center of the arrow key under the AUDIO adjustment cover to quit the auto-check.

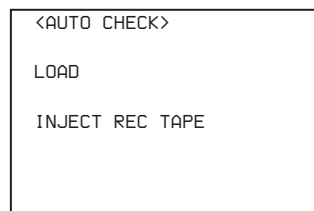

- 4** Insert the cassette to be used for test recording and playback, and close the cassette lid (*page 46*).  
Check the REC/SAVE switch of the cassette before inserting it, and if the switch is set to SAVE, set it to REC and then insert the cassette.

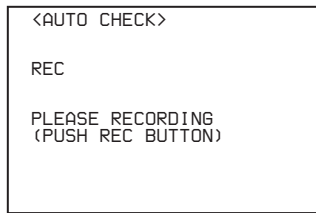

- 5** Press the REC button on the camcorder or the VTR button on the lens.

Test recording starts.  
After about 1 minute, the tape is rewound to the recording start position and playback starts. The following is displayed during playback.

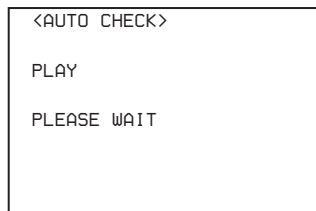

- 6** Check the recording quality of the playback video on the viewfinder or the monitor. Check the recording quality of the playback audio from the speaker, earphone, or headphones.

**If the recording quality is poor**

A problem may exist regardless of whether or not it is detected by the internal check. Refer to “*Troubleshooting*” on *page 129* and repeat the test. If the recording quality remains poor, contact your Sony dealer.

When playback ends, the results of the internal check are displayed.

- 7** After confirming the result (see the next section, “*Confirming the result*”), press the center of the arrow key under the AUDIO adjustment cover.

The auto-check is completed.

**To confirm the result**

When the results of the internal check are normal, the following message appears. You can use the camcorder if there are no problems with the recording quality of the video and audio.

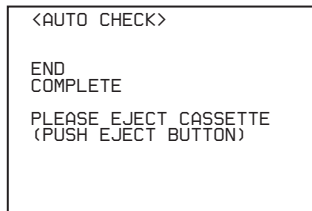

If a problem is indicated in the results, follow the instructions in the table below to check the camcorder and cassette. If no errors can be found, contact your Sony dealer.

Also, be sure to check the quality of the playback video and audio (see step 7).

Display	Diagnostic result
ERROR CODE 000	Ordinary warnings or cautions are indicated. See “ <i>Operation Warnings</i> ” on <i>page 126</i> .
ERROR CODE 001	Recording on the inserted cassette is not enabled. Insert a cassette that is recordable and repeat the auto-check.
ERROR CODE 002 to 009	A problem in the VTR’s internal operations has occurred. Repeat the auto-check. If the result is the same, contact your Sony dealer.
ERROR CODE 010 to 023	A problem in the VTR’s internal operations has occurred. Clean the video heads using the DVM-12CLD Cleaning Cassette and repeat the auto-check. If the result is the same, contact your Sony dealer.

# About i.LINK

This unit is equipped with a DV IN/OUT connector that complies with the i.LINK (IEEE 1394) standard. This section explains the specifications and features of i.LINK.

## What is i.LINK?

i.LINK is a digital serial interface designed to integrate devices equipped with i.LINK connectors. i.LINK allows your device to:

- Perform two-way transmission and reception of data such as digital audio and digital video signals.
- Control other i.LINK devices.
- Easily connect multiple devices with a single i.LINK cable.

Your i.LINK device is capable of connecting to a wide range of digital AV devices for data transfer and other operations.

Other advantages include the following feature. When connected to multiple i.LINK devices, your i.LINK device can perform data transfer and other operations not only with the directly connected devices but also with any of the devices that are connected to those devices. Therefore, you do not need to be concerned with device connection order. However, depending on the features and specifications of the connected devices, you may need to use certain functions differently, and you may not be able to transfer data or perform certain operations.

i.LINK, a nickname for IEEE 1394 proposed by Sony, is a trademark supported by many companies worldwide. IEEE 1394 is an international standard defined by IEEE, the Institute of Electrical and Electronics Engineers, Inc.

## About data transfer speed of i.LINK

i.LINK defines a maximum data transfer speed of approximately 100, 200 and 400 Mbps\* that are described as S100, S200 and S400 respectively.

For i.LINK devices, a maximum data transfer speed that the device supports is identified on “specifications” page of the operating instructions supplied with the device or near its i.LINK connector.

With a device that does not identify the data transfer speed, the maximum data transfer speed that the device supports is S100.

When connecting with the device that support different data transfer speed, the actual data transfer speed may be different from those described on the i.LINK connectors.

### \* What is Mbps?

Mega bits per second. A measure of the rate at which data is transmitted per second. In case of 100 Mbps, 100 Mega bits of data can be transmitted per second.

## i.LINK operation with your camcorder

For details on operation when other equipment with i.LINK (DV) connector is connected, see *page 42*.

For details on connection with i.LINK cable and necessary software, refer to the operating instructions supplied with the connected device.

### Use Sony i.LINK cables

Use Sony i.LINK cables to connect the i.LINK devices.

6 pins ↔ 4 pins (For dubbing)

6 pins ↔ 6 pins (For dubbing)

i.LINK and  are trademarks.

# About a “Memory Stick”

## What is “Memory Stick”?

“Memory Stick” is a new compact, portable and versatile IC (Integrated Circuit) recording medium with a data capacity that exceeds a floppy disk. “Memory Stick” is specially designed for exchanging and sharing digital data among “Memory Stick” compatible products. Because it is removable, “Memory Stick” can also be used for external data storage.

“Memory Stick” is available in two sizes: standard size and compact “Memory Stick Duo” size. Once attached to a “Memory Stick Duo” adapter, “Memory Stick Duo” turns to the same size as standard “Memory Stick” and thus can be used with products compliant with standard “Memory Stick”.

## Types of “Memory Stick”

“Memory Stick” is available in the following four types to meet various requirements in functions.

### “Memory Stick-R”

Stored data are not overwritten. You can write data to “Memory Stick-R” with “Memory Stick-R” compatible products only. Copyright protected data that requires MagicGate copyright protection technology cannot be written to “Memory Stick-R”.

### “Memory Stick”

Stores any type of data except copyright-protected data that requires the MagicGate copyright protection technology.

### “MagicGate Memory Stick”

Equipped with the MagicGate copyright protection technology.

### “Memory Stick-ROM”

Stores pre-recorded, read-only data. You cannot record on “Memory Stick-ROM” or erase the pre-recorded data.

## Available types of “Memory Stick”

You can use a “Memory Stick” and “MagicGate Memory Stick” with your product.

### Note

You can not use a “Memory Stick Duo” with your product.

## Note on data read/write speed

Data read/write speed may vary depending on the combination of the “Memory Stick” and “Memory Stick” compliant product you use.

## What is MagicGate?

MagicGate is copyright protection technology that uses encryption technology.

## Before using a “Memory Stick”

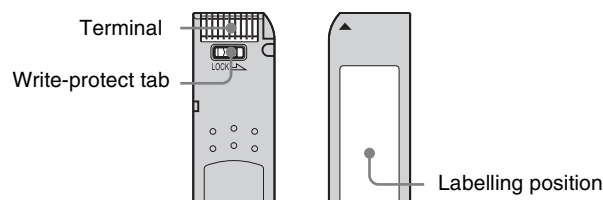

- When you set the “Memory Stick” erasure prevention switch to “LOCK,” data cannot be recorded, edited, or erased.
- Data may be damaged if:
  - You remove the “Memory Stick” or turn off the unit while it is reading or writing data.
  - You use the “Memory Stick” in a location subject to the effects of static electricity or electric noise.
- We recommend that you make a backup copy of important data that you record on the “Memory Stick”.

### Notes

- Do not attach anything other than the supplied label to the “Memory Stick” labelling position.
- Attach the label so that it does not stick out beyond the labelling position.
- Carry and store the “Memory Stick” in its case.
- Do not touch the connector of the “Memory Stick” with anything, including your finger or metallic objects.
- Do not strike, bend, or drop the “Memory Stick”.
- Do not disassemble or modify the “Memory Stick”.
- Do not allow the “Memory Stick” to get wet.
- Do not use or store the “Memory Stick” in a location that is:
  - Extremely hot, such as in a car parked in the sun
  - Under direct sunlight
  - Very humid or subject to corrosive substances

## “Memory Stick” access indicator

If the access indicator is turned on or is flashing, data is being read from or written to the “Memory Stick”. At this time, do not shake the computer or product or subject them to shock. Do not turn off the power of the computer and product or remove the “Memory Stick”. This may damage the data.

## Precautions

- To prevent data loss, make backups of data frequently. In no event will Sony be liable for any loss of data.
- Unauthorized recording may be contrary to the provisions of copyright law. When you use a “Memory Stick” that has been pre-recorded, be sure that the material has been recorded in accordance with copyright and other applicable laws.
- The “Memory Stick” application software of the camcorder may be modified or changed by Sony without prior notice.
- Note that there are certain restrictions on recording stage performances and other entertainment events, even if they are recorded for personal use only.

- “Memory Stick” and  are trademarks of Sony Corporation.
- “Memory Stick Duo” and “**MEMORY STICK DUO**” are trademarks of Sony Corporation.
- “MagicGate” and “**MAGIC GATE**” are trademarks of Sony Corporation.

# Operation Warnings

When a problem occurs at power on or during operation, a warning is given by one of the following.

- Warning indicators on the STATUS screen of the LCD monitor
- WARNING lamps, and audible warnings from the speaker and earphones
- Indicators on the viewfinder

The volume of the audible warnings can be adjusted with the ALARM knob. Set the ALARM knob to the minimum to mute the sound.

STATUS screen of the LCD monitor and viewfinder	WARNING lamp	Warning sounds	Indicators in viewfinder		Problem	VTR operation	Action to take
			REC/TALLY	BATT			
Warning indicator	:Continuous :1 flash/s :4 flashes/s	<b>Continuous</b> :1 beep/s :4 beeps/s	:Continuous :1 flash/s :4 flashes/s	:Continuous :1 flash/s :4 flashes/s			
Warning: RF	1)	1)	1)		Clogging of the video head. Trouble in the recording section.	A warning sound is heard when clogging of the head is detected. Recording may fail.	Clean the video head. If recording still fails after cleaning the head, turn off the power and consult your Sony representative.
Warning: SERVO	2)	2)	2)		Servo problems.	Recording continues but may be substandard.	Turn off the power and consult your Sony representative.
Warning: HUMID					Condensation occurs.	During recording, recording continues. Otherwise, operation stops. Ejecting the tape is the only operation allowed.	While the power is turned on, wait until the HUMID indicator disappears.
Warning: SLACK Er **_***					Trouble when forwarding or rewinding a tape.	Operation stops.	Follow the instructions given in the error code list (page 128).
							Turn off the power and consult your Sony representative. <sup>3)</sup>
Warning: CASSETTE Er **_***					Trouble when inserting or ejecting a cassette.	Operation stops.	Follow the instructions given in the error code list (page 128).
							Turn off the power and consult your Sony representative.

STATUS screen of the LCD monitor and viewfinder	WARNING lamp	Warning sounds	Indicators in viewfinder		Problem	VTR operation	Action to take
			REC/TALLY	BATT			
Warning indicator	☀ :Continuous ☀ :1 flash/s ☀ :4 flashes/s	Continuous ●●●●●●●●●● 1 beep/s ●●●●●●●●●● 4 beeps/s ●●●●●●●●●●	☀ :Continuous ☀ :1 flash/s ☀ :4 flashes/s				
Warning: REFERENCE	☀	●●●●●●●●●●	☀		Reference signal problem during recording.	A warning sound is heard when a reference signal problem is detected during recording. Recording continues but may be substandard.	Check if the reference signal is input appropriately to the GENLOCK IN connector.
Warning: TAPE (remaining tape capacity also flashes.)	☀ <sup>1)</sup>	●●●●●●●●●● <sup>1)</sup>	☀ <sup>1)</sup>		Tape almost full.	Operation continues.	Change the tape when necessary.
	☀	●●●●●●●●●●	☀		Tape full.	Operation stops during recording, playback, and fast-forwarding.	Change the tape or rewind it.
Warning: BATT (remaining battery capacity also flashes.)	☀	●●●●●●●●●●	☀	☀	Battery almost exhausted.	Operation continues.	Change the battery when necessary.
	☀	●●●●●●●●●●	☀	☀	Battery exhausted.	Operation stops.	Change the battery.
Warning: LID OPEN <sup>2)</sup>	—	—	—		The lid of the cassette compartment is not closed.	Operation continues.	An indicator appears for several seconds and disappears automatically. Close the lid securely.

1) During recording

2) During recording and playback

3) Note that a tape is damaged if the camcorder is operated while “SLACK” is displayed.

*For details about the warning displays and error messages on the viewfinder, see page 128.*

## Error code list

Error code	Action to take
Er07-***	Turn off the power and consult your Sony representative. Or you may be able to eject the cassette using the following procedure. However, because it may damage the cassette, any damage is your responsibility. <b>When “Warning: SLACK” appears</b> <b>1</b> Turn off the camcorder. This may take about 15 seconds. <b>2</b> When the camcorder is turned off, turn it on again. <b>3</b> If the error code disappears, change the cassette because it may be damaged. If the error message appears again, turn off the power and consult your Sony representative. <b>When “Warning: CASSETTE” appears</b> <b>1</b> Press and hold the STOP button and the EJECT button at the same time for more than 3 seconds. <b>2</b> When the PLAY button, the REW button, and the FF button all flash at one time, release your fingers. <b>3</b> If the cassette is ejected, change the cassette because it may be damaged. If the error message appears again, turn off the power and consult your Sony representative.
Er08-***	
Er09-***	
Er09-200	
Er09-500	
Er09-600	Turn off the power and consult your Sony representative.
Er09-900	
Er91-***	Turn off the power and consult your Sony representative.
Er92-***	

*When the error code other than the ones listed above is displayed, turn off the power and consult your Sony representatives.*

## Operation/error messages

An operation or error message is displayed in the operation/error message display area (*page 23*) in the viewfinder.

Operation/error message	Meaning
INTERVAL	Indicates the camcorder is in the Interval Rec mode.
LOW LIGHT	Appears, depending on the setting, to indicate the subject illumination is inadequate.
HIGH TEMPERATURE	Indicates the internal temperature of the camcorder has increased. If this warning appears, stop the operation and turn the power of the camcorder off.



# Troubleshooting

You can use this chart to establish possible causes of an apparent problem; always double-check before sending the camcorder for repair. If a problem persists, contact your Sony dealer.

When the indication “Er00-\*\*\*” appears in the LCD monitor, see “Error code list” on page 128.

Symptoms	Cause	Remedy
The camcorder does not power on when you turn the POWER switch on.	There is no battery pack loaded.	Attach a battery pack (page 30).
	The battery pack is exhausted.	Replace the battery pack with a fully charged one (page 30).
	The AC adaptor is not connected, or it is not turned on.	Connect the AC adaptor, or turn on the POWER switch of the AC adaptor (page 30).
The tape transport does not operate when you press either VTR button.	The POWER switch is turned off.	Set the POWER switch to ON.
	The camcorder has reached the end of tape.	Rewind the tape, or load a new cassette.
	The cassette is set record-inhibited.	Load a new cassette, or release the record-inhibit (page 49).
The tape transport does not operate when you press the PLAY button.	The camcorder has reached the end of tape.	Rewind the tape, or load a new cassette.
The power supply cuts while operating.	The battery pack is exhausted.	Replace the battery pack with a fully charged one (page 30).
The battery goes dead very quickly.	The operating temperature is very low.	Use a BP-GL95 (page 30).
	The battery pack is inadequately charged.	Recharge the battery pack (page 30).
It is not possible to eject the cassette.	The battery pack is exhausted.	Replace the battery pack with a fully charged one (page 30).
	The POWER switch is turned off.	Turn the POWER switch to ON.
The playback picture quality is poor. The playback picture does not appear. The playback sound does not hear.	The video heads are dirty.	Clean the video heads using a DVM-12CLD Cleaning Cassette (page 121).
All controls except the EJECT button are disabled.	There is condensation.	Remove the cassette and wait with the power on until the condensation has evaporated (page 120).
Audio recording is not possible.	The AUDIO LEVEL (CH-1/CH-2) knobs are set to the minimum level.	Adjust the setting of the AUDIO LEVEL (CH-1/CH-2) controls (page 15).
Audio recording is not possible (CH-1 only).	The AUDIO LEVEL knob on the front is set to the minimum level.	Adjust the setting of the AUDIO LEVEL knob on the front (page 11).
The recorded sound is distorted.	The audio level is too high.	Adjust the setting of the AUDIO LEVEL (CH-1/CH-2) knobs, and record again (page 15).
The recorded sound has a high noise level.	The audio level is too low.	Adjust the setting of the AUDIO LEVEL (CH-1/CH-2) knobs, and record again (page 15).
The cassette is automatically ejected.	An incorrect type of cassette is inserted.	Insert a correct type of cassette (page 48).
The equipment connected to the camcorder via an i.LINK connection carries out unintended operations, such as recording automatically.	The settings of the camcorder and the connected equipment (the VTR TRIGGER switch, etc.) are incorrect.	Set correctly. See “Using an i.LINK Connection” on page 42.



Symptoms	Cause	Remedy
The equipment connected to the camcorder via an i.LINK connection does not react as expected, for example, the video image does not appear on its screen.	It sometimes takes time for the connected equipment to recognize the operation.	Wait for about 15 seconds. If the connected equipment still does not react, do the following. <ul style="list-style-type: none"> <li>• Check the i.LINK connection, for example, by re-inserting the i.LINK cable.</li> <li>• Turn the power off, and connect the cable again.</li> <li>• Change the i.LINK cable.</li> </ul>
The camera is not recognized by the PC that is connected to the i.LINK connector.	There is a problem with the software, for example, it does not support the DVCAM format, etc.	Install software that supports the DVCAM format.
The camera is not controlled by the PC that is connected to the i.LINK connector.	There is a problem with the software, for example, it does not support the DVCAM format, etc.	Install software that supports the DVCAM format. Or set the REC TRIGGER switch to INT.

# Specifications

## General

Power voltage	12 V DC +5.0/-1.0 V
Power consumption	Approx. 17 W (with 12 V DC supply, when recording with the LCD monitor off)
Operating temperature	0°C to +40°C (32°F to 104°F)
Storage temperature	-20°C to +60°C (-4°F to +140°F)
Recording format	DVCAM, DV-SP
Continuous operating time	Approx. 300 min. (with BP-GL95)
Mass	Approx. 3.9 kg (8 lb 10 oz) (main body only) Approx. 6.5 kg (14 lb 5 oz) (with viewfinder, microphone, tape, BP-GL65 Battery Pack, and VCL-917BY Zoom Lens)
Dimensions	

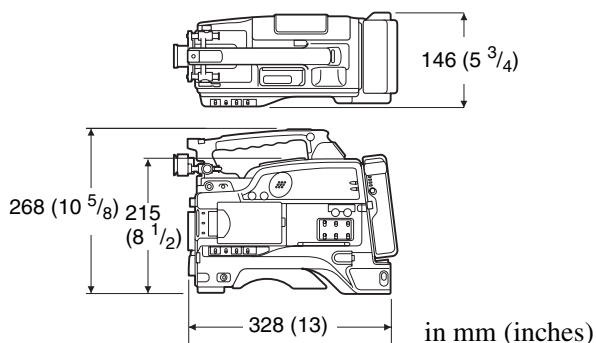

## Supplied accessories

- VCL-917BY Zoom Lens (1) (supplied with DSR-400K/400PK only)
- DXF-801 Viewfinder (1)
- Microphone (1)
- Wind screen (1)
- Shoulder strap (1)
- VCT-U14 Tripod Adaptor (1)
- Lens mount cap (1)
- Flange focal length adjustment test chart (1)
- Operating Instructions
  - English version (1)
  - Japanese version (1)
  - CD-ROM manual (1)

## Video Camera Section

### General

Imager	2/3-inch type, Power HAD EX CCD
Total picture elements	1038 (H) × 1008 (V) (DSR-400/450WS), or 1038 (H) × 1188 (V) (DSR-400P/450WSP)
Effective picture elements	980 (H) × 988 (V) (DSR-400/450WS), or 980 (H) × 1064 (V) (DSR-400P/450WSP)

### Imager Configuration

RGB 3 CCDs

### Spectral system

F1.4 prism system (with quartz filter)

### Built-in filter

- ND filter
- 1: Clear
- 2: 1/4 ND
- 3: 1/16 ND
- 4: 1/64 ND

### Lens mount

2/3-inch 48 bayonet mount

### Sensitivity

F11 standard (89.9% reflection chart, 2000 lx)

### Minimum illumination

0.51x (at F1.4, +36 dB gain)

Video S/N ratio 65 dB (Y-typical) (DSR-400/450WS), or 63 dB (Y-typical) (DSR-400P/450WSP)

### Modulation

DSR-450WS/450WSP: 850 TV lines (4:3 mode), 800 TV lines (16:9 mode)  
DSR-400/400P: 920 TV lines

### Registration

0.05% or less for entire screen area (excluding distortion due to lens)

### Geometric distortion

None identified (excluding distortion due to lens)

### Smear

-140 dB (Y-typical)

### LCD monitor

Picture: 6.3 cm (2 1/2 inches) in opposite angle (2.5 type)  
Pixel resolution: 214,000 pixels (964 wide × 222 high)  
Effective picture elements: more than 99.99%

### Viewfinder

#### CRT

1.5-inch monochrome

#### Indicator

REC (× 2), TALLY, BATT, SHUTTER, GAIN UP

#### Horizontal resolution

600 TV lines

#### Power voltage

12 V DC

#### Power consumption

2.4 W

#### Mass

Approx. 620 g (1 lb 6 oz)

#### Maximum dimensions

241 × 91 × 203 mm (9 1/2 × 3 5/8 × 8 inch) (w/h/d)

## Microphone

Type	Black electret condenser microphone
Directivity	Super cardioid
Frequency response	100 Hz to 20 kHz
Output impedance	100 $\Omega$
Power voltage	48 V DC
Mass	Approx. 115 g (4 oz)
Dimensions	162 $\times$ 21 mm (6 1/2 $\times$ 27/32 inch) (length $\times$ diameter) (excluding cable)

## Tape section

### General

Video recording system	2 rotary heads, Helical scanning system
Audio recording system	2 rotary heads Quantization: 12bits Fs32K (channels 1/2, channels 3/4) 16bits Fs48K (channels 1/2)
Video signal	NTSC color, EIA standards (DSR-400/450WS) PAL color, CCIR standards (DSR-400P/450WSP)
Usable cassette	DVCAM cassette with the <b>DVCAM</b> <sup>™</sup> mark printed, DV cassette with the <b>DV</b> mark printed, Mini DV cassette with the <b>Mini DV</b> mark printed
Tape speed	DVCAM format: Approx. 28.193 mm/s (DSR-400/450WS), or 28.221 mm/s (DSR-400P/450WSP) DV format SP mode: Approx. 18.795 mm/s (DSR-400/450WS), or 18.814 mm/s (DSR-400P/450WSP)
Recording/playback time	DVCAM format: 184 min. (using cassette PDV-184ME) DV format SP mode: 276 min. (using cassette PDV-184ME)
Fast-forward/rewind time	Approx. 45 sec. (using cassette DVM60/PDVM-40ME) Approx. 2 min 30 sec. (using cassette PDV-184ME)
Loading time	Approx. 15 sec.
<b>Video system (at playback with the DSR-1800A)</b>	
Bandwidth	Luminance (Y): 30 Hz to 5.0 MHz $\pm$ 1.0 dB Chrominance (R-Y/B-Y): 30 Hz to 1.5 MHz $\pm$ 1.0/-5.0 dB
S/N ratio	Luminance: Min. 55 dB
K-factor (2T pulse)	Max. 2%
Y/C time delay	Max. 30 nsec.

## Audio system (at playback with the DSR-1800A)

Frequency response	48 kHz: 20 Hz to 20 kHz $\pm$ 0.5/-1.0 dB 32 kHz: 20 Hz to 14.5 kHz $\pm$ 0.5/-1.0 dB
Dynamic range	Min. 80 dB
Distortion (THD) (1 kHz reference level, 48 kHz)	Max. 0.12%

## Input/output connectors

### Signal inputs

AUDIO IN CH-1/CH-2	XLR type, 3-pin, female -60 dBu/+4 dBu (0 dBu = 0.775 Vrms)
MIC IN	XLR type, 3-pin, female -60 dBu
GENLOCK IN	BNC type, 1.0 Vp-p, 75 $\Omega$ , unbalanced
TC IN	BNC type, 0.5 V to 18 Vp-p, 10 k $\Omega$

### Signal outputs

AUDIO OUT CH-1/CH-2	RCA type, -10 dBu, 47 k $\Omega$
MONITOR OUT	BNC type, 1.0 Vp-p, 75 $\Omega$ , unbalanced
VIDEO OUT (DSR-450WS/450WSP only)	BNC type, 75 $\Omega$ , unbalanced VBS OUT: 1.0 Vp-p SDI OUT: 0.8 Vp-p (only when the CBK-SD01 is installed)
TC OUT	BNC type, 1.0 Vp-p, 75 $\Omega$
EARPHONE (mini jack)	8 $\Omega$ , - $\infty$ to -18 dBs variable

### Others

DC IN	XLR type, 4-pin, male, 11 to 17 V DC
DC OUT	4-pin, 11 to 17 V DC, maximum rated current 0.2 A
LENS	12-pin
REMOTE	8-pin
LIGHT	2-pin
i.LINK	6-pin

## VCL-917BY Zoom Lens (supplied with the DSR-400K/400PK)

Focal length	9 to 155 mm (3/8 to 6 1/8 inches)
Zoom control	Power or manual, selectable
Zoom ratio	17:1
Maximum aperture	1:1.9 (f=9 to 115 mm) 1:2.6 (f=155 mm)
Iris control	Power or manual, selectable F1.9 to F16, and C (close)
Angle of view	Wide: 815 $\times$ 611 mm (32 1/8 $\times$ 24 1/8 inches) Tele: 47 $\times$ 36 mm (1 7/8 $\times$ 1 7/16 inches)
Focusing range	Infinity to 0.9 m
Filter attachment thread size	82 mm dia., 0.75 mm pitch

Mount Sony 2/3-type bayonet mount  
 Mass 1.24 kg (2 lb 4 1/8 oz) (not including the lens hood)  
 External dimension 123 × 102 × 220.5 mm (4 7/8 × 4 × 8 3/4 inch) (w/h/d) (including the lens hood, not including the lens grip)

## Pin assignment of the connectors

### DC IN connector (4-pin, male)

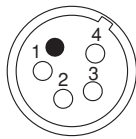

Pin number	Signal	Standard
1	EXT DC IN (G)	GND
2	—	—
3	—	—
4	EXT DC IN (X)	+11 to +17Vdc

### AUDIO IN CH-1/CH-2 connector (3-pin, female)

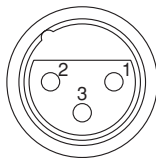

Pin number	Signal	Standard
1	MIC IN (G)	GND
2	MIC IN (X)	−60dBu
3	MIC IN (Y)	When Z1 is equal to or more than 3kΩ/ +4dBu, 10kΩ BALANCED

## Related Products

There is a range of Sony products available to meet every conceivable video shooting requirement. For details, consult your Sony sales representative or supplier.

### Power supply and related equipment

BP- GL65/GL95/L60S Battery Pack  
 BC-M50/M150 Battery Charger  
 AC-550 AC Adaptor  
 AC-DN10 AC Adaptor

### Equipment for remote control

RM-B150/B750 Remote Control Unit (can be installed to the DSR-450WS/450WSP only)

### “Memory Stick”

MSH-32 (32 MB)

MSH-64 (64 MB)  
 MSH-128 (128 MB)

## Audio equipment

ECM-670/672 Microphone  
 CAC-12 Microphone Holder  
 WRR-855 UHF Synthesized Tuner Unit  
 WRR-861/862 UHF Portable Tuner  
 WRT-822/824 UHF Transmitter  
 WRR Tuner Fitting (service part number: A-8278-057-A)  
 DMX-P01 Portable Digital Mixer

*For Audio equipment described above, confirm whether the connector is male or female and the number of pins on the connector.*

*The audio input connectors of the camcorder are female and 3-pin. A converting adaptor may be required.*

## Studio equipment

DXF-51 5-inch Viewfinder (monochrome)  
 Accessory Shoe Kit for DXF-51 (service part number: A-8274-968-B)

## Extension boards (DSR-450WS/450WSP only)

CBK-SD01 SDI Output Board  
 CBK-SC01 Composite Input Board

## Cables and miscellaneous

i.LINK cable (DV connecting cable)  
 CCFD-3L (6-pin ↔ 4-pin, 3.5m)  
 CCF-3L (6-pin ↔ 6-pin, 3.5m)  
 LC-H300 Hard Carrying Case  
 LC-DS300SFT Soft Carrying Case  
 LCR-1 Rain Cover

Design and specifications are subject to change without notice.

## Notes

- Always make a test recording, and verify that it was recorded successfully.  
 SONY WILL NOT BE LIABLE FOR DAMAGES OF ANY KIND INCLUDING, BUT NOT LIMITED TO, COMPENSATION OR REIMBURSEMENT ON ACCOUNT OF FAILURE OF THIS UNIT OR ITS RECORDING MEDIA, EXTERNAL STORAGE SYSTEMS OR ANY OTHER MEDIA OR STORAGE SYSTEMS TO RECORD CONTENT OF ANY TYPE.
- Always verify that the unit is operating properly before use.  
 SONY WILL NOT BE LIABLE FOR DAMAGES OF ANY KIND INCLUDING, BUT NOT LIMITED TO, COMPENSATION OR REIMBURSEMENT ON ACCOUNT OF THE LOSS OF PRESENT OR PROSPECTIVE PROFITS DUE TO FAILURE OF THIS UNIT, EITHER DURING THE WARRANTY PERIOD OR AFTER EXPIRATION OF THE WARRANTY, OR FOR ANY OTHER REASON WHATSOEVER.

# Chart of Optional Components and Accessories

## For DSR-400/400P

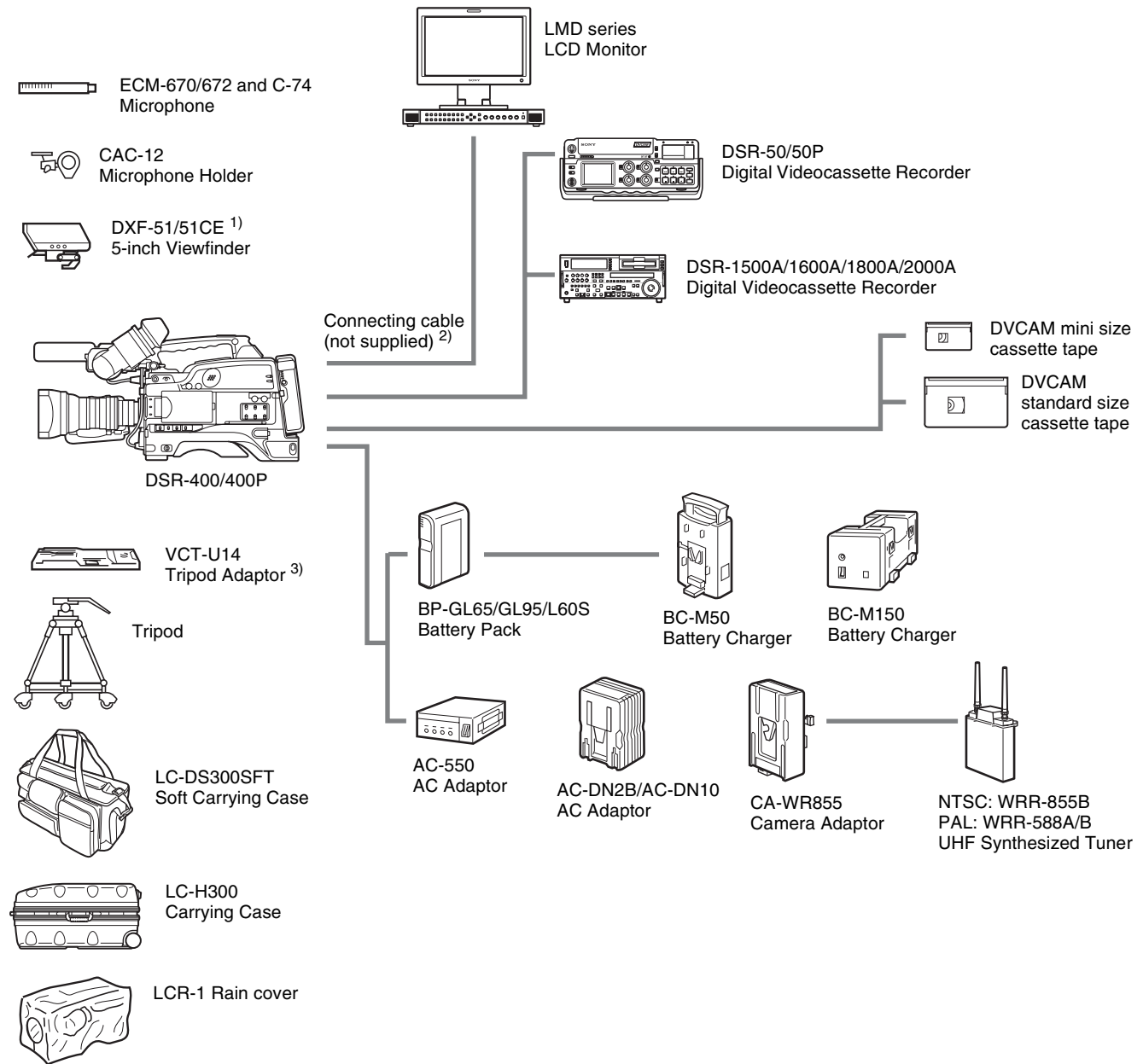

- 1) Optional accessory shoe kit (service part number: A-8274-968-B) is required for fitting. For details, consult your Sony dealer.
- 2) Depending on the equipment connected, use an appropriate cable. For details, see *Chapter 3 "Connections" on page 41.*
- 3) Use the supplied tripod adaptor. For details, see *"Fitting to a Tripod" on page 34.*

# For DSR-450WS/450WSP

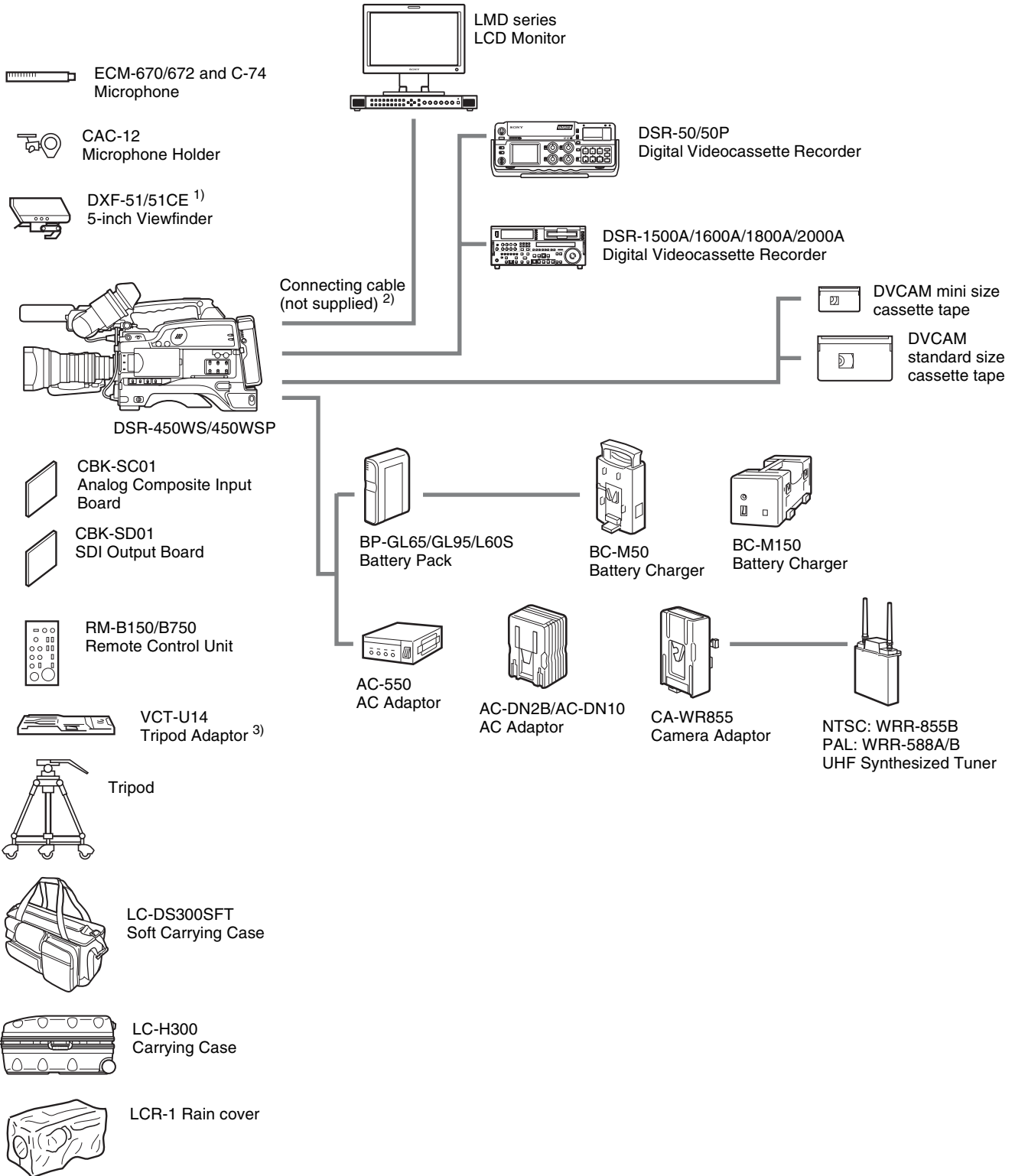

1) Optional accessory shoe kit (service part number: A-8274-968-B) is required for fitting. For details, consult your Sony dealer.  
 2) Depending on the equipment connected, use an appropriate cable. For details, see *Chapter 3 "Connections" on page 41.*  
 3) Use the supplied tripod adaptor. For details, see *"Fitting to a Tripod" on page 34.*

---

# Glossary

## ATW

Auto Tracing White balance. The white balance is automatically adjusted for the lighting conditions during shooting.

## Bayonet type

A type of lens mount. The lens can be inserted into the lens mount and fixed in place by rotating a ring.

## Black balance

To balance the black level of the R, G, and B signals so that black has no color.

## CCD

Abbreviation for charge-coupled device. A semiconductor used in place of a camera tube. The CCD converts light into electrical charge, and outputs the electrical charge in the form of varying voltages.

## Center marker

A cross on the viewfinder screen that indicates the center of an image.

## Color bar signals

Test signals displayed on the screen as multicolored vertical stripes. Used for adjustment of hue, and saturation of a video camera and video monitor.

## Color conversion filter (CC filter)

A filter that converts the color temperature to a reference value so the same picture tone is obtained in different lighting conditions.

## Color temperature

The color quality of light, expressed in Kelvin (K).

## Composite video signal

A signal that consists of video (luminance and color sub carrier), sync (horizontal and vertical), and color burst signals.

## CTL

Abbreviation for control signal. A signal that you can count to determine the number of frames, and therefore the tape's running time. It is

used mainly to adjust the tracking position of video heads, and to achieve time code continuity when recording continuously. This signal is recorded in a longitudinal tape track.

## DCC

Abbreviation for dynamic contrast control. In a high contrast environment, this function compresses the high light signal by adjusting the knee point automatically, allowing you to take clear pictures in a dynamic range.

## Drop frame mode

SMPTE time code runs at 30 frames/second, while the NTSC color television system runs at about 29.97 frames/second. Drop frame mode adjusts the running of time code to eliminate the discrepancy between time code value and actual time by dropping two frames from the time code value at the beginning of each minute except every tenth minute.

## Drum

A metal cylinder to which the video heads are attached. During recording and playback, the drum rotates at high speed in synchronization with a control signal.

## EBU

Abbreviation for European Broadcasting Union. A professional broadcasting establishment in Europe.

## EXT TC (External time code)

A time code input from external equipment together with audio data. It corresponds to the conventional time code recorded on tape based media. Instead the EXT TC is usually used to record time codes and audio signals that are played back by equipment that is not synchronized with the reference video signal.

## Ff

See "*Flange focal length*".

## Flange focal length

The length between the objective lens and the surface of the imager.

## Flare

The loss of contrast in an image caused by unnecessary light that strays into the image plane.

## Flicker

Repeated changes in screen brightness caused by an interference between the camera's scanning and the lighting conditions.

## GENLOCK

A state in which devices are locked to a signal output by a sync generator. Genlock allows multiple devices to operate in synchronization.

## HAD

Abbreviation for hole-accumulated diode. A CCD sensor structure designed to suppress certain types of noise inherent to CCDs.

## Head drum

See "*Drum*".

## Horizontal resolution

The horizontal resolution of the screen, which is expressed as the number of vertical lines distinguishable when shooting a test chart.

## i.LINK

Another name for the IEEE1394-1995 standards and their revisions. XDCAM uses the i.LINK interface to transfer DV streams by the AV/C protocol, and to read and write MPEG IMX and DVCAM data files by FAM (File Access Mode).

## Interlaced scan mode

A scanning method in which odd rows fields are read alternately with even rows. (Odd-row fields and evenrow fields contain images from different times.)

## ND filter

Abbreviation for neutral density filter. A filter that reduces the amount of incident light equally across the entire visible wavelength range without affecting color.

## Non-drop frame mode

A mode of advancing time code which ignores the difference in frame values between real time and the time



code. Using this mode produces a difference of approximately 86 seconds per day between real time and time code, which causes problems when editing programs in units of seconds using the number of frames as a reference.

### **NTSC**

Abbreviation for National Television System Committee. NTSC is a color TV broadcasting system adopted mainly in North American countries, and in parts of Asia and Central and South America.

### **PAL**

Abbreviation for Phase Alternating Line. PAL is a color TV broadcasting system developed by Telefunken GmbH of Germany. This system is adopted mainly in European countries, in Australia, and in parts of Asia and South America.

### **Progressive scan mode**

A scanning method in which odd rows and even rows are read at the same time. Also called full-screen scanning.

### **Reference video signal**

A video signal that contains a sync signal or sync and burst signals, used as a reference for synchronization of video equipment.

### **Return video**

Video signals that are sent back from a VTR to a camera or from a control console to a camera so that a camera operator can verify the recorded/selected video signals.

### **Sampling frequency**

A method used to sample an analog signal so that it can be represented digitally. The higher the sampling frequency is, the more accurately the high-frequency analog signal can be represented.

### **SDI**

Serial Digital Interface. An interface standardized as SMPTE 259M which enables the transmission of an uncompressed digital component stream.

### **Servo**

A mechanism that controls the number and phase of revolutions of the head drum, capstan, or reel tables. The servo mechanism allows recording and playback of the video signal without guard band noise. The reference signal of the servo control is normally a vertical sync signal.

### **Shot data**

Data recorded, while shooting, in the color bars, the user bits data of VITC, and so forth. Includes the model name, serial number, date, time, shot number, and ID1 to ID4.

### **Shutter speed**

The time that the shutter is open. Slow shutter speeds give bright images, but motion resolution is lower.

### **SMPTE**

Society of Motion Picture and Television Engineers, a professional association established in the U.S.A. mainly for the purpose of setting forth motion picture and television engineering standards.

### **Stand-by off mode**

A mode in which the head drum is stationary and the tape is slack. It means that the VTR is not ready for immediate recording or playback. It does not mean that the tape or video heads are damaged.

### **Stand-by on mode**

A mode in which the head drum rotates with the tape wrapped around it. It means that the VTR is ready for recording or playback. The VTR comes into Stand-by off mode in a settled time not to damage tape and video head.

### **Superimpose**

A procedure you use to put one picture (or character) over another so that both can be seen at the same time.

### **Time code**

A digital signal recorded on the videotape that supplies information such as the hour, minute, second and frame number of each frame. There are two kinds of recorded signal:

longitudinal time code (LTC) and vertical interval time code (VITC).

### **Time code synchronization**

To synchronize the built-in time code generator of video equipment to an external time code.

### **Time data**

Time information that is generated by a time code generator or read by a time code reader.

### **User's bits**

A 32-bit section of time code in which you can record desired information such as the year, month, date and reel numbers.

### **VBS**

Abbreviation for video-burst-sync. A composite signal consisting of a video signal, a burst signal, and a sync signal.

### **VITC**

Abbreviation for vertical interval time code. A time code recorded on tape with video signals and inserted in the vertical blanking interval of video signals. The VTR can read this time code even in still mode.

### **White balance**

The adjustment of red, green and blue signal levels so that white objects are reproduced as true white.

### **White shading**

A phenomenon whereby the upper and lower portions of the white object that you are shooting appear magenta or green, while the central portion of the image appears white.

### **Zebra pattern**

Striped patterns that appear in the viewfinder to indicate areas of the picture where the video level is about 70 IRE units or 490 mV.

### **Zoom**

To gradually change the field of view of a camera lens from wide to narrow angle (zoom in) or narrow to wide angle (zoom out).

# Index

## Symbols

\* (Asterisk indicator) 23

## Numerics

16:9 mode recording indicator 23

16:9/4:3 mode indicator 24

24P mode 108

5600 indicator 24

5600K button 11

## A

AC adaptor 30

Accessory shoe 16

ALARM knob 12

ALL FILE page 90

Analog composite signals 65

Arrow key 15

ASSIGN 1/2 switches 11

ASSIGN 3/4 switches 16

Assigning functions to ASSIGN switches 107

Attaching the microphone 35

Attaching the video light 34

Attachment shoe for large viewfinder 17

ATW 12

AUDIO adjustment cover 14

Audio format 25

AUDIO IN CH-1/CH-2 connectors 19

AUDIO IN input selection switches 19

AUDIO IN switches 16

Audio input

Using an external microphone 35

Using the supplied microphone 35

Audio level

Adjusting 58

Indicator 23

AUDIO LEVEL controls (side) 15

Audio level indicators 25

AUDIO LEVEL knob (front) 11

AUDIO OUT CH-1/CH-2 connectors 19

AUDIO page 87

AUDIO SELECT switches 15

AUTO IRIS page 79

AUTO IRIS 2 page 88

AUTO SHADING page 89

AUTO W/B BAL switch 10

Auto-check function 121

Automatic iris  
setting 56  
Window 57

## B

Back space editing 62

BATT indicator 22

Battery attachment interface 18

Battery capacity indicator 25

Battery pack

Attaching 30

Detaching 30

Operation time 30

BATTERY page 86

Black balance

Adjusting 51

BLACK GAMMA page 82

BLACK SHADING page 86

BLACK/FLARE page 81

BRIGHT control 22

Built-in speaker 14

## C

Camera scan mode indicator 24

CAMERA STATUS window 103

Cassette

Compatibility of DVCAM and DV formats 49

Ejecting 46

Inserting 46

Inserting a mini-size cassette 46

Usable cassettes 48

Cassette lid 17

CD-ROM manual 26

CLK 26

CM indicator 25

CNT 26

Color temperature

Indicator 23

Setting 105

Compatibility of DVCAM and DV formats 49

Connecting line input audio equipment 38

CONTRAST control 21

Controlling the camcorder from a non-linear editing system 44

Correcting skin detail 61

## D

DAT 26

Date/time

Indicator 24

Setting 106

DC IN / battery voltage or remaining capacity 23

DC IN connector 18

DC OUT 12 V connector 19

DCC (Dynamic Contrast Control) 12

DCC ADJUST page 87

DETAIL 1 page 83

DETAIL 2 page 83

DETAIL 3 page 83

DEV STATUS 1 page 92

DEV STATUS 2 page 93

DIAGNOSIS menu 92

Digital copy 43

DISP SEL button 13

DISPLAY button 13

DISPLAY switch 22

DVCAM cassettes 48

DXF-51 32

DXF-801 7, 21

## E

EARPHONE jack 14

ECS 54

EDIT SEARCH + FWD/- REV buttons 14

Edit search function 63

E-E 14

EJECT switch 17

Electronic shutter 53

Error code 128

EVS 54

EXT/IV indicator 23

Extender 23

External synchronization indicator 24

Eyepiece focusing knob 21

Eyepiece release catch 22

## F

F FWD button and indicator 14

F.f adjustment ring 20

F.f fixing knob 20

Features 8

FILE menu 89

Filter indicator 24

FILTER selector 10

Setting and examples of shooting conditions 10

Fitting for optional microphone holder 17

Flange focal length 29

Flicker 51

Focal servo module connector 20

Focus ring 20

FORMAT page 80

FRONT MIC LOW CUT switch 16

F-RUN/SET/R-RUN switch 15

FUNCTION 1 page 77

FUNCTION 2 page 77

FUNCTION 3 page 88

- G**
- Gain
    - Indicator 24
    - Setting values for the GAIN selector positions 104
  - GAIN SW page 78
  - GAIN switch 12
  - GAIN UP indicator 22
  - GAMMA page 82
  - GENLOCK IN connector 17
  - GENLOCK page 89
- H**
- Hold indicator 25
  - HOURS METER page 92
- I**
- I (interlace scan) mode 108
  - i.LINK 123
    - Checking the playback image recorded on an external VTR 43
    - Connecting 42
    - Making backup of recording image 42
    - REC TRIGGER switch 16, 42
    - Settings required for an i.LINK connection 42
    - Using the camcorder as a feeder 43
  - i.LINK CTL setting 42
  - i.LINK DV OUT connector 9, 19, 42
  - ID number 24
  - Instant automatic iris adjustment button 20
  - Interval rec 64
    - INTERVAL TIME 64
    - REC TIME 64
    - Settings before shooting 64
    - Shooting 64
  - Iris 56
  - Iris ring 20
  - Iris selector 20
  - Iris sensitivity 57
  - Iris sensitivity trimmer 57
  - Iris setting/auto iris override 23
- K**
- KNEE page 82
- L**
- LCD button 13
  - LCD monitor 12, 13
    - Display 24
    - Status display 99
  - Lens 20
  - LENS connector 10
  - LENS FILE page 80
  - LENS FILE 1 page 91
  - LENS FILE 2 page 91
  - LENS FILE 3 page 91
  - Lens locking lever 11
  - Lens mount 10
  - Lens mount cap 10
  - LIGHT connector 17
  - LIGHT switch 11, 21
  - Lithium battery
    - Attaching and Replacing 28
    - Service life 28
    - Warning Indicator 25
  - Lithium battery compartment 15
  - LOW KEY SAT page 85
- M**
- MACRO ring 21
  - MACRO selector 20
  - MAINTENANCE menu 85
  - MARKER 1 page 78
  - MARKER 2 page 78
  - “Memory Stick” 124
    - Displaying a file-related menu page 118
    - Handling 110
    - Inserting 110
    - Protecting saved data 111
    - Removing 110
  - MEMORY STICK page 91
  - “Memory Stick” slot 18, 110
  - Menu
    - Adjustments and settings 104
    - Basic operations 94
    - DIAGNOSIS menu 92
    - Displaying 94
    - Ending 94
    - FILE menu 89
    - MAINTENANCE menu 85
    - OPERATION menu 76
    - Organization 67
    - PAINT menu 81
    - TOP menu 74
  - MENU knob 11
  - MENU switch 12
  - MIC IN connector 17
  - Model name and serial number indicators 24
  - MONITOR knob 12
  - MONITOR OUT CHARACTER switch 15
  - MONITOR OUT connector 17
  - MONITOR OUT page 76
  - MONITOR SELECT switch 15
  - Motorized zoom lever 20
  - Mounting the lens 29
  - MTX LINEAR page 84
  - MTX MULTI page 84
- N**
- ND COMP page 89
  - Non drop-frame indicator 24
- O**
- OFFSET WHT page 79
  - OPERATION menu 76
  - Operation/error message display area 23
  - OPTION BOARD page 93
  - OUTPUT page 76
  - OUTPUT/DCC switch 12
  - Overview 7
- P**
- PAINT menu 81
  - PEAKING control 21
  - PLAY button and indicator 14
  - Playback
    - Indicator 24
    - On the color video monitor 66
    - Recording review 66
  - Power supply
    - Preparing 30
  - POWER switch 12
  - Pre-lighting function 64
  - PRESET WHT page 87
  - PRESET/REGEN/CLOCK switch 15
  - Product configurations 7
  - PsF (progressive scan) mode 108
  - Pulldown 108
- R**
- REC button 10
  - REC TRIGGER switch 16
  - REC/TALLY indicators 22
  - Recording format
    - Indicator 23
    - Selecting 50
  - Recording review 66
  - Recording shot data superimposed on the color bars 102
  - Reference file 117
  - REFERENCE page 90
  - Remaining tape capacity 23
  - REMOTE connector 19
  - Remote control unit
    - Camcorder switch functions when connected 38
    - Connecting 38
    - Paint adjustment when connected 38
    - RM-B150/B750 38

Using settings of the paint  
adjustment data stored in  
the “independent data  
region” even when you  
disconnect a remote  
control unit 40

RESET button 13  
RET button 20  
REW button and indicator 14  
RM-B150/B750 38

## S

Scan mode 108  
Scene file  
  Loading 116  
  Loading scene files from a  
  “Memory Stick” into the  
  camcorder memory 117  
  Saving 114  
  Setting the file ID 115  
SCENE FILE page 85, 90  
Selecting the aspect ratio 107  
Selecting the display items 99  
Selecting the lens file 107  
Selecting the output signals 105  
SET STATUS page 79  
Setting change and adjustment  
  progress message display area 23  
Setting change confirmation/  
  adjustment progress messages  
  Changing the display mode 100  
Setting for special shooting cases 61  
Setting the marker display 101  
Setting the shot ID 102  
Setup add 66  
Setup remove 65  
Shooting 47  
SHOT DISP page 79  
SHOT ID page 79  
Shoulder pad 18  
  Adjusting the position 33  
Shoulder strap  
  Fitting and removing 33  
Shoulder strap fitting 16  
SHT ENABLE page 80  
SHUTTER indicator 22  
Shutter mode 53  
Shutter speed 53  
  Indicator 23  
SHUTTER switch 11  
SKIN DETAIL page 83  
SLS 54, 55  
SOURCE SEL page 80  
Status confirmation windows  
  Disabling display 104  
  Displaying 104  
STOP button 14  
Stopper 21

SW STATUS page 81  
Synchronizing two or more  
  camcorders 45

## T

TALLY indicator 18, 22  
Tally lamp 22  
TALLY switch 18  
TALLY switch (viewfinder) 22  
TAPE indicator 14  
Tape indicator 17  
Tape remaining indicator 25  
TC IN connector 18  
TC OUT connector 18  
TCG 26  
TCR 26  
Time code  
  Indicator 24  
  Making the time code  
  consecutive 59  
  Saving the actual time 59  
  Setting 58  
  Synchronizing 59  
Time counter indicator 26  
TIME/DATE page 92  
Trigger mode 23  
Tripod  
  Fitting/removing 34

## U

UBG 26  
UBR 26  
User bit  
  Setting 59  
User file  
  Loading 113  
  Saving 111  
  Setting the file ID 112  
USER FILE page 89  
USER FILE 2 page 89  
USER menu  
  Canceling setting 96  
  Editing 96  
  Moving to another page 96  
  Returning to the standard  
  settings 96  
  Setting 95  
USER MENU CUSTOMIZE menu  
  Adding a new page 96  
  Adding/deleting/replacing pages  
  98  
  Resetting USER menu settings to  
  the standard settings 99

## V

V MODULATION page 84

VCL-917BY 7, 20  
VCT-U14 7, 34  
VF connector 10  
VF DISP 1 page 77  
VF DISP 2 page 78  
VF SETTING page 78  
Video format 24  
VIDEO OUT connector 19  
Viewfinder 7, 21  
  Adjusting contrast and  
  brightness 32  
  Adjusting the eyepiece focus 32  
  Adjusting the outline emphasis 32  
  Adjusting the position 32  
  Attaching a 5-inch electronic  
  viewfinder 32  
  Fitting the viewfinder 31  
  Left eye adaptor 32  
  Removing 31  
  Setting 101  
  Status display on the screen 99  
Viewfinder connector 22  
Viewfinder fitting shoe 17  
Viewfinder front-to-back position  
  locking knob 16  
Viewfinder left-to-right positioning  
  ring 16  
VTR button 21  
VTR MODE page 87  
VTR operation indicators 22  
VTR STATUS window 103

## W

WARNING indicator 14  
Warning indicators 26  
WHITE BAL switch 12  
White balance  
  Adjusting 52  
  Offset 106  
  Saving in the scene file 115  
  White balance memory  
  indicator 24  
WHITE page 81  
WHITE SHADING page 85  
Wireless microphone system  
  WRR-855 37  
  WRR-861 37  
  WRR-862 37  
WRR connector 19

## Z

ZEBRA button 11  
Zoom remote control connector 20  
Zoom ring 20  
ZOOM selector 20

