

SONY®

HD CAMCORDER

HDW-730

HDW-750

HDW-750P

HDCAM

 Tele-File



MEMORY STICK™

OPERATION MANUAL
1st Edition (Revised 1)

English

WARNING

To prevent fire or shock hazard, do not expose the unit to rain or moisture.

To avoid electrical shock, do not open the cabinet. Refer servicing to qualified personnel only.

AVERTISSEMENT

Afin d'éviter tout risque d'incendie ou d'électrocution, ne pas exposer cet appareil à la pluie ou à l'humidité.

Afin d'écartier tout risque d'électrocution, garder le coffret fermé. Ne confier l'entretien de l'appareil qu'à un personnel qualifié.

WARNUNG

Um Feuergefahr und die Gefahr eines elektrischen Schlages zu vermeiden, darf das Gerät weder Regen noch Feuchtigkeit ausgesetzt werden.

Um einen elektrischen Schlag zu vermeiden, darf das Gehäuse nicht geöffnet werden. Überlassen Sie Wartungsarbeiten stets nur qualifiziertem Fachpersonal.

For the customers in USA

This equipment has been tested and found to comply with the limits for a Class B digital device, pursuant to Part 15 of the FCC Rules. These limits are designed to provide reasonable protection against harmful interference in a residential installation. This equipment generates, uses, and can radiate radio frequency energy and, if not installed and used in accordance with the instructions, may cause harmful interference to radio communications. However, there is no guarantee that interference will not occur in a particular installation. If this equipment does cause harmful interference to radio or television reception, which can be determined by turning the equipment off and on, the user is encouraged to try to correct the interference by one or more of the following measures:

- Reorient or relocate the receiving antenna.
- Increase the separation between the equipment and receiver.
- Connect the equipment into an outlet on a circuit different from that to which the receiver is connected.
- Consult the dealer or an experienced radio/TV technician for help.

You are cautioned that any changes or modifications not expressly approved in this manual could void your authority to operate this equipment.

The shielded interface cable recommended in this manual must be used with this equipment in order to comply with the limits for a digital device pursuant to Subpart B of Part 15 of FCC Rules.

For the customers in Europe

This product with the CE marking complies with the EMC Directive (89/336/EEC) issued by the Commission of the European Community.

Compliance with this directive implies conformity to the following European standards:

- EN55103-1: Electromagnetic Interference (Emission)
- EN55103-2: Electromagnetic Susceptibility (Immunity)

This product is intended for use in the following Electromagnetic Environment(s):

E1 (residential), E2 (commercial and light industrial), E3 (urban outdoors) and E4 (controlled EMC environment, ex. TV studio).

Pour les clients européens

Ce produit portant la marque CE est conforme à la Directive sur la compatibilité électromagnétique (EMC) (89/336/CEE) émise par la Commission de la Communauté européenne.

La conformité à cette directive implique la conformité aux normes européennes suivantes:

- EN55103-1: Interférences électromagnétiques (émission)
- EN55103-2: Sensibilité électromagnétique (immunité)

Ce produit est prévu pour être utilisé dans les environnements électromagnétiques suivants:

E1 (résidentiel), E2 (commercial et industrie légère), E3 (urbain extérieur) et E4 (environnement EMC contrôlé, ex. studio de télévision).

Für Kunden in Europa

Dieses Produkt besitzt die CE-Kennzeichnung und erfüllt die EMV-Direktive (89/336/EEC) der EG-Kommission.

Die Erfüllung dieser Direktive bedeutet Konformität für die folgenden Europäischen Normen:

- EN55103-1: Elektromagnetische Interferenz (Emission)
- EN55103-2: Elektromagnetische Empfindlichkeit (Immunität)

Dieses Produkt ist für den Einsatz unter folgenden elektromagnetischen Bedingungen ausgelegt:

E1 (Wohnbereich), E2 (kommerzieller und in beschränktem Maße industrieller Bereich), E3 (Stadtbereich im Freien) und E4 (kontrollierter EMV-Bereich, z.B. Fernsehstudio)

Table of Contents

Chapter 1 Overview

1-1	Features	1-1
	1-1-1 Camera Features	1-1
	1-1-2 VTR Features	1-4
1-2	Precautions	1-7
1-3	Example of System Configuration	1-8

Chapter 2 Locations and Functions of Parts and Controls

2-1	Power Supply	2-1
2-2	Accessory Attachments	2-3
2-3	Audio Functions	2-5
2-4	Shooting and Recording/Playback Functions	2-14
2-5	Menu Operating Section	2-29
2-6	Time Code System	2-33
2-7	Warnings and Indications	2-39
2-8	Warnings and Indications on the Display Panel	2-42
2-9	Indicators on the Viewfinder	2-46

Chapter 3 Recording and Playback

3-1	About Cassettes	3-1
	3-1-1 Loading and Unloading a Cassette	3-1
	3-1-2 Preventing Accidental Erasure	3-5
3-2	Recording	3-6
	3-2-1 Basic Procedures	3-6
	3-2-2 Continuous Recording	3-12
	3-2-3 Recording Good Shot Markers	3-15
	3-2-4 Recording a Recording Start Marker	3-20
	3-2-5 Starting a Shoot with a Few Seconds of Pre-Stored Picture Data (Loop Rec Function) (When Using an HKDW-703 Extension Board)	3-20

(Continued)

3-2-6	Shooting Pictures at Intervals (Interval Rec Function) (When Using an HKDW-703)	3-28
3-2-7	Continuous Recording on the Previous Cut	3-52
3-2-8	Searching for the Last Recorded Portion and Turning in the Recording Pause Mode (End Search Function) ..	3-53
3-3	Checking the Recording — Playback	3-55
3-3-1	Checking the Last Two Seconds of the Recording — Recording Review	3-55
3-3-2	Checking the Recording on the Color Video Monitor — Playback in Color	3-56
3-4	Recording the Recording Start Time Code onto the Memory Label — Tele-File	3-58
3-5	Freezing a Picture during Playback	3-63
3-6	Setting the Stand-by off Timer During Rec-Pause	3-66

Chapter 4 Adjustments and Settings for Recording

4-1	Adjusting the Black Balance and the White Balance	4-1
4-1-1	Adjusting the Black Balance	4-2
4-1-2	Adjusting the White Balance	4-6
4-2	Setting the Electronic Shutter	4-12
4-2-1	Shutter Modes	4-12
4-2-2	Selecting the Shutter Mode and Speed	4-14
4-3	Changing the Reference Value for Automatic Iris Adjustment	4-21
4-4	Adjusting the Audio Level	4-28
4-5	Setting the Time Data	4-36
4-5-1	Setting the Time Code	4-36
4-5-2	Saving the Real Time in the Time Code	4-38
4-5-3	Setting the User Bits	4-39
4-5-4	Synchronizing the Time Code	4-41

4-6	Menu Display on the Viewfinder Screen	4-46
4-6-1	Menu Configuration	4-46
4-6-2	Basic Use of the Menu	4-49
4-6-3	Editing the USER Menu	4-55
4-7	Status Display on the Viewfinder Screen	4-64
4-7-1	Layout of the Status Display on the Viewfinder Screen	4-65
4-7-2	Selecting the Display Items	4-70
4-7-3	Display Mode and Setting Change and Adjustment Progress Messages	4-73
4-7-4	Setting the Marker Display	4-75
4-7-5	Setting the Viewfinder	4-78
4-7-6	Recording Superimposed Shot Data in Color Bars	4-81
4-7-7	Setting the Shot ID	4-84
4-7-8	Displaying the Status Confirmation Windows	4-90
4-7-9	Confirming the Image of the Return Video Signal on the Viewfinder	4-94
4-8	Adjustments and Settings from Menus	4-98
4-8-1	Setting the GAIN Selector Values	4-98
4-8-2	Selecting the Output Signals	4-101
4-8-3	Setting the Color Temperature Manually	4-104
4-8-4	Specifying an Offset for the Auto White Balance Setting	4-106
4-8-5	Assigning Functions to ASSIGN 1/2 Switches	4-109
4-8-6	Setting the Date/Time of the Internal Clock	4-114
4-8-7	Selecting the Lens File	4-116
4-9	Saving/Loading User Menu Data to/from Memory Stick	4-118
4-9-1	Handling the Memory Stick	4-118
4-9-2	Saving/Loading User Menu Data to/from Memory Stick	4-122
4-10	Resetting USER Menu Settings to the Standard Settings	4-133

(Continued)

4-11	Using the Scene Files	4-135
4-11-1	Storing Data in the Scene File	4-135
4-11-2	Loading Scene Files	4-145
4-11-3	Resetting the Settings of the Camcorder to the Standard Settings Saved in the Reference File	4-150
4-12	Jumping to a File-Related Menu Page When Inserting a Memory Stick	4-151

Chapter 5 Setting Up the Camcorder

5-1	Power Supply	5-1
5-1-1	Using a Battery Pack	5-1
5-1-2	Avoiding Breaks in Operation Due to Dead Batteries	5-4
5-1-3	Using an AC Adaptor	5-5
5-1-4	Using the Anton Bauer Ultralight System	5-6
5-2	Adjusting the Viewfinder	5-7
5-2-1	Adjusting the Viewfinder Position	5-7
5-2-2	Adjusting the Viewfinder Focus and Screen	5-9
5-2-3	Detaching the Viewfinder	5-10
5-2-4	Detaching the Eyepiece	5-12
5-3	Mounting the Lens	5-14
5-4	Adjusting the Flange Focal Length	5-15
5-5	Audio Input System	5-17
5-5-1	Using the Supplied Microphone	5-17
5-5-2	Using an External Microphone	5-19
5-5-3	Attaching a UHF Portable Tuner (for a UHF Wireless Microphone System)	5-24
5-5-4	Connecting Line Input Audio Equipment	5-28
5-6	Tripod Mounting	5-29
5-7	Attaching the Shoulder Strap	5-31
5-8	Adjusting the Shoulder Pad Position	5-33
5-9	Putting On the Rain Cover	5-34
5-10	Connecting the Remote Control Unit	5-36

Chapter 6 Maintenance

6-1	Testing the Camcorder Before Shooting	6-1
6-1-1	Preparations for Testing	6-1
6-1-2	Testing the Camera	6-2
6-1-3	Testing the VTR	6-5
6-2	Maintenance	6-11
6-2-1	Cleaning the Video Heads	6-11
6-2-2	Cleaning the Viewfinder	6-11
6-3	Operation Warnings	6-14

Appendix

Specifications	A-1
Video Camera Section	A-2
VTR Section	A-3
Supplied Accessories	A-6
Recommended Additional Equipment	A-6
Menu List	A-9
OPERATION Menu List	A-9
PAINT Menu List	A-19
MAINTENANCE Menu List	A-31
FILE Menu List	A-46
DIAGNOSIS Menu List	A-49
About a “Memory Stick”	A-50
Index	I-1

1-1 Features

The HDW-730/750/750P¹⁾ HD Camcorder combines an HD color video camera, of which the effective picture elements are 1920(H) × 1080(V) and which uses 2/3-type Power HAD²⁾ sensor CCD³⁾ imagers with 2,000,000 picture elements, with an HDCAM portable videocassette recorder. Its excellent image quality, sensitivity, portability, and dust- and water-proof construction make it ideal as a camcorder for ENG⁴⁾ and EFP⁵⁾ in the same way as the earlier BVW-400A/400AP. The introduction of a new integrated circuit technology (LSI) for processing HD digital signals improves the image quality even further and simplifies setup (initialization) operations.

1-1-1 Camera Features

The features of the HDW-730/750/750P camera are described below.

- 2/3-type Power HAD sensor CCDs with 2,000,000 picture elements provide a compact and lightweight unit with excellent image quality. The HDW-750/750P uses FIT⁶⁾-type CCDs and the HDW-730 uses IT⁷⁾-type CCDs.
- Existing 2/3-inch lenses can be used.
- A new integrated circuit technology for digital signal processing has improved picture quality and functionality.
- A setup menu enables you to control features such as status displays, messages, and markers; to select various types of settings; to toggle switches; and to operate a Memory Stick⁸⁾.

1) The HDW-730 can operate with either the 59.94I or the 50I format. The HDW-750 operates with the 59.94I format. The HDW-750P can operate with either the 50I or the 25PsF format. The descriptions given in this manual apply to all models, any differences being clearly noted in the text.

2) Power HAD: Power Hole-Accumulated Diode
“Power HAD” is a registered trademark of Sony Corporation.

3) CCD: Charge-Coupled Device

4) ENG: Electronic News Gathering

5) EFP: Electronic Field Production

6) FIT: Frame Interline Transfer

7) IT: Interline Transfer

8) “Memory Stick” is a trademark of Sony Corporation.

- Blur-free shooting is ensured by a built-in, high-performance electronic shutter that provides a variety of modes, such as ECS¹⁾ mode which reduces flickering on the monitor screen, and EVS²⁾ mode for the HDW-730 and S-EVS³⁾ mode for the HDW-750/750P⁴⁾ which improve vertical resolution.
- Selectable video gain ensures a noise-free image.
- A simple switch operation enables automatic adjustment of the black set, black balance, and white balance. Memory functions make it easy to replicate the white balance setting appropriate for the lighting conditions.
- The ATW⁵⁾ function automatically adjusts the white balance for the varying lighting conditions during shooting.
- The “TruEye”⁶⁾ process is used to ensure naturally colored pictures even when shooting very bright subject.
- The video gain can be boosted to 42 dB instantly using the TURBO GAIN button.
- Character display functions on the viewfinder indicate switch settings, automatic black and white balance adjustment, status indications, and warnings.
- The warning system uses various types of warning indicators and sounds to inform you of VTR faults, end of tape, low battery, etc.
- The camcorder is equipped with a dual-wheel filter disk for adjusting the filter setting to the shooting and lighting conditions.
- Override function which makes fine adjustment of the reference value for brightness of automatic iris control is provided.

1) ECS: Extended Clear Scan

2) EVS: Enhanced Vertical definition System

3) S-EVS: Super Enhanced Vertical definition System

4) When the HDW-750P operates with the 25PsF format, neither S-EVS mode nor EVS mode is available

5) ATW: Auto Tracing White balance

6) TruEye: “TruEye” is a registered trademark of Sony Corporation.

- A built-in circuit produces a color bar signal for easy adjustment of the color monitor.
- The RM-B150 remote control unit (not supplied) controls camera functions and VTR functions.
- Setup data made on the USER menu, including the various marker settings, can be stored on a Memory Stick as a user file. After storage, it can be recalled.
- Setup data specified by video engineers, including the various detail settings, can be stored in the camcorder itself and on a Memory Stick as a reference file. After storage it can be loaded. This makes it possible to shorten setup time by duplicating the stored reference file to other cameras through the Memory Stick.
- Setup data specified by video engineers, including the video settings, can be stored in the camcorder itself and on a Memory Stick as a scene file. This makes it possible to load setup data appropriate for the scene.
- Correction values for lens extenders and individual lenses can be stored as a lens file. The values can then be recalled. This makes it possible to shorten adjustment time when the lens is replaced.
- A high-performance viewfinder is adjustable forward, backward, and sideways, and has a full range of auxiliary equipment.
- The camcorder is provided with the XLR 5-pin connector, which allows connection of a stereo microphone. The ASSIGN 1/2 switches allow microphone mode to be switched between stereo and monaural.
- The HD SDI output (corresponding to Embedded Audio) makes it possible to monitor the camera image and playback image.
- Attaching an HKDW-702 down converter (not supplied) (converting to a 525i/625i signal ¹⁾) allows the camera image and playback image to be monitored on an NTSC/PAL monitor. This board makes it possible to output the SDI signal (corresponding to Embedded Audio).

1) When an HKDW-702 is attached to an HDW-750 or an HDW-730 which operates with the 59.94I format, the HD signal is down-converted to a 525i signal. When an HKDW-702 is attached to an HDW-750P or an HDW-730 with the 50I format, the HD signal is down-converted to a 625i signal.

- Three down converter modes are available: SQUEEZE, LETTER BOX and CROP.
- The camcorder is provided with the LIGHT connector. This feeds power to the light from a battery or AC adaptor connected to the camcorder.
- The viewfinder supplied with NTSC/PAL type camcorders, such as the BVW-400A/400AP, can be attached to HDW-730/750/750P in emergencies (only when an HKDW-702 (not supplied) is attached). Some functions are not available with this viewfinder.
- The camcorder has the ASSIGN 1/2 switches, which can be assigned functions.

1-1-2 VTR Features

The VTR features of this camcorder are described below.

- Use of the HDCAM format allows high performance HD digital recording and playback while preserving the same ease of use as conventional camcorder equipment.
- The same cassette size (S size) as Digital BETACAM can be used to achieve a long recording time of approximately 40 minutes (for 59.94I format) and 48 minutes (for 50I/25PsF format).
- No playback adaptor is needed to see the color playback image on the monitor screen.
- The 4 times normal speed search function provides quick positioning of the tape.
- LTC¹⁾ and VITC²⁾ recording and LTC playback can be performed.
- It is possible to record recording start markers and good shot markers on the tape while shooting, and search automatically for required cuts when editing.

1) LTC: Longitudinal Time Code

2) VITC: Vertical Interval Time Code

- It is possible to automatically rewind and review the last 2 seconds of the recording on the tape for a quick check immediately after shooting.
- Compatible with the Tele-File¹⁾ Memory Label system.
By pressing the RET button on the lens while recording, the timecode valid when you pressed the button is recorded on a MLB-1M-100 memory label (not supplied) attached to the cassette. This is very helpful for management of the cassette tapes and to improve the efficiency of the tape editing.
- The built-in time code generator can be synchronized with an external generator.
- A lithium battery is the back-up power supply for the built-in time code generator enabling the time code to be held for approximately 5 years without charging the camcorder power supply.
- Optional long-life battery packs are available.
- Pressing the VTR START button on the camcorder or the VTR button on the lens ensures recording continuity from the very next frame.
- The time code is displayed in the LCD window screen even when the power is off. The automatic power shut-off function has three time code indication settings.
- The camcorder continuously stores a few seconds of the most recent picture data. Recording is started with this data when the REC button is pressed. This prevents the loss of picture data (Loop Rec function). (This feature is available when an HKDW-703 (not supplied) is attached.)
- The camcorder can shoot pictures at intervals. (This feature is available when an HKDW-703 (not supplied) is attached.)
- A slot-in UHF portable tuner WRR-855A/855B (not supplied) can be attached.

1) Tele-File

The Tele-File system is a non-contact data reading/writing system. It allows a variety of data to be stored on a 1/2-inch tape label with a non-contact IC memory.

- Four channels of analog audio can be converted to 20-bit digital signals. The converted four channels of digital audio can then be recorded.
- Connecting an HDCA-901 camera adaptor (not supplied) allows the input of four audio channels. This also makes it possible for the HD-SDI signal to be output.
- When connecting the audio cable to AUDIO IN CH-1/CH-2 connectors (XLR 3-pin), the audio signals input to the XLR 3-pin are recorded regardless of the AUDIO IN switch setting. This function is called the XLR connection automatic detection function.
- The AUDIO OUT connector (XLR 5-pin) allows the camcorder to output signals from two channels at the same time (stereo recording).
- The camcorder searches for the most recently recorded cut and records the new cut over it. (RE-TAKE function)
- The camcorder searches for the point most recently recorded on the tape and automatically switches to paused recording mode (rec pause). (End Search function)
- The camcorder can record GPS data with the video data on the tape. (This feature is available when an HKDW-704 GPS UNIT is attached.)

1-2 Precautions

Use and Storage

Do not subject the camcorder to severe shocks

The internal mechanism may be damaged or the body warped.

After use

Always turn off the power.

Before storing the camcorder for a long period

Remove the battery pack.

Use and storage locations

Store in a level, ventilated place. Avoid using or storing the camcorder in the following places.

- Places subject to temperature extremes
- Very damp places
- Places subject to severe vibration
- Near strong magnetic fields
- In direct sunlight or close to heaters for extended periods

To prevent electromagnetic interference from portable communications devices

The use of portable telephones and other communications devices near this unit can result in misoperations and interference with audio and video signals.

It is recommended that the portable communications devices near this unit be powered off.

Note on laser beams

Laser beams may damage the CCDs. If you shoot a scene that includes a laser beam, be careful not to let a laser beam become directed into the lens of the camera.

1-3 Example of System Configuration

1

The diagram below shows a typical configuration of the camcorder for ENG and EFP.

For more information about the fittings, connections, or use of additional equipment and accessories, see Chapter 5 as well as the operation manuals for the connected equipment.

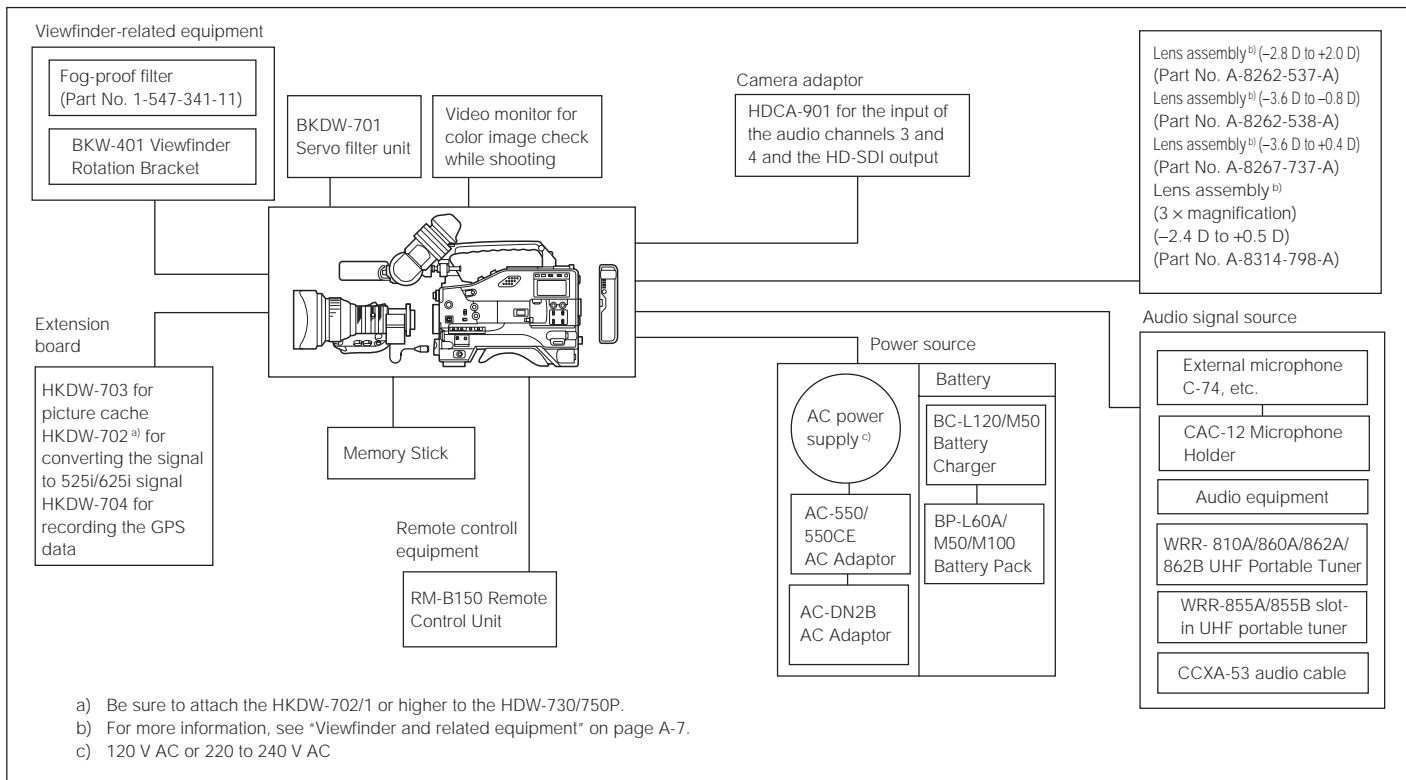

2-1 Power Supply

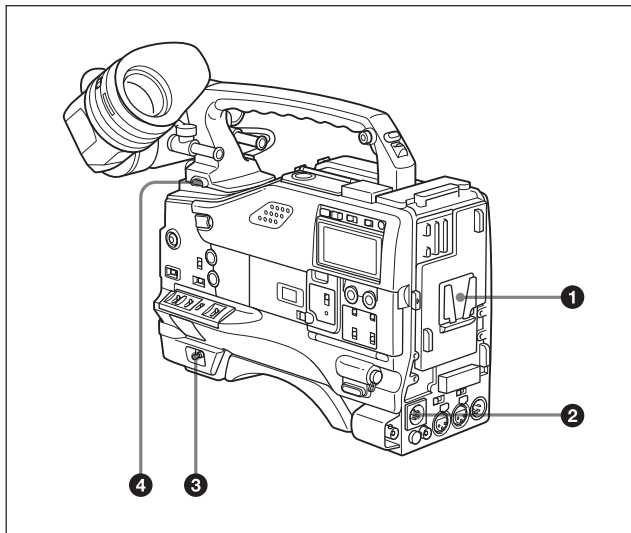

Power supply

❶ Battery attachment

Attach a BP-L60A/M50/M100 battery pack.

Furthermore, by attaching an AC-DN2B AC Adaptor, you can operate the camcorder from AC power.

❷ DC IN (external power input) connector (XLR type, 4-pin, male)

To operate the HDW-730/750/750P using an AC power supply, connect an AC-550/550CE AC Adaptor with the DC output cable supplied with the adaptor.

To use an external battery, connect its DC output cable to the DC IN connector.

③ POWER switch

This switch turns the main power supply on and off.

④ LIGHT switch

This switch selects the way in which a video light connected to the LIGHT connector is switched on and off.

AUTO: When the video light switch is turned on, starting recording with the VTR turns on the light.

MANUAL: The video light switch controls the light, turning it on and off manually.

2-2 Accessory Attachments

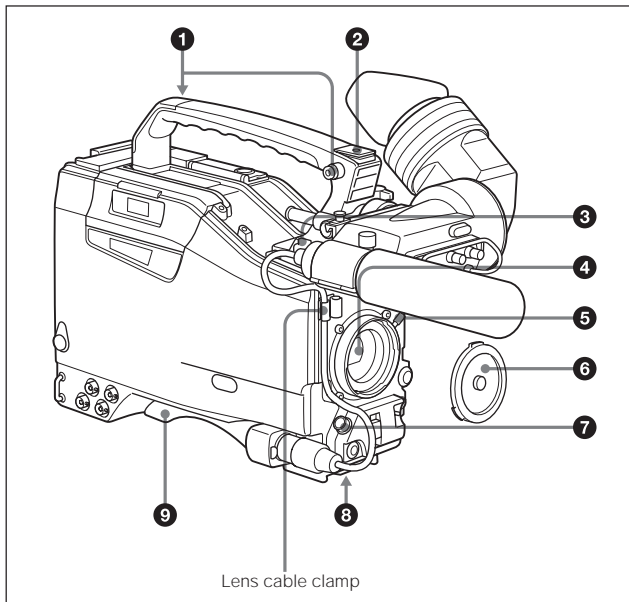

Accessory attachments

❶ Shoulder strap posts

Attach the supplied shoulder strap to these posts.

❷ Light shoe

Attach an optional accessory such as a video light to this shoe.

3 LIGHT connector (2-pin, female)

Connect the cable of the Anton Bauer Ultralight System attached to the light shoe. The system operates with lights powered by 12 V, with a maximum power consumption of 50 W.

4 Lens mount (special bayonet mount)

Use this for mounting the lens.

5 Lens locking lever

After inserting the lens in the lens mount, rotate the lens mount ring with this lever to lock the lens in position.

6 Lens mount cap

Remove this cap by pushing up on the lens locking lever. For protection from dust, always insert this cap when no lens is mounted.

7 LENS connector (12-pin)

Fit the lens cable to this connector. Contact your Sony representative for more information about the lens you are using.

8 Tripod mount

When using the unit on a tripod, attach the supplied tripod adaptor.

9 Shoulder pad

You can move the shoulder pad forwards or backwards by loosening the two screws. Do this to ensure the best balance when shooting with the camcorder on your shoulder.

Note

Do not remove screws instead of loosening them. If you have removed them, be sure to use the screws you removed, or screws of the same length (8 mm). If you fasten the shoulder pad using longer screws, they may damage parts inside the unit.

2-3 Audio Functions

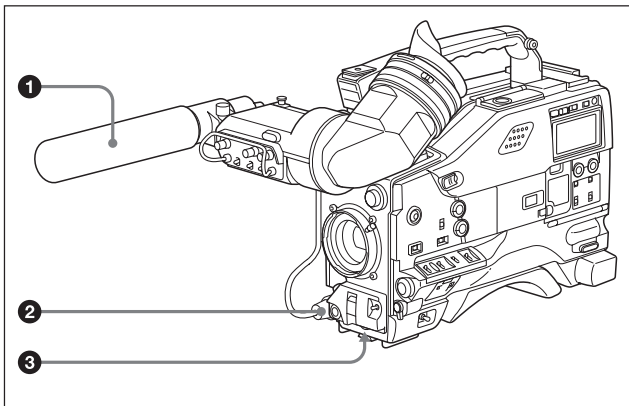

Audio functions (1)

1 Microphone

This is a super-cardioid directional stereo microphone with an external power supply (+48 V) system.

If you assign the Front MIC MONO/STEREO function to either ASSIGN 1 or 2 switch, you can switch the monaural and stereo outputs.

2 MIC IN (microphone input) connector (XLR type, 5-pin, female)

You can connect a supplied stereo microphone with an external power supply system. The connector supplies power (+48 V) to the microphone.

3 MIC LEVEL knob

This knob adjusts the audio level of the microphone connected to the MIC IN connector.

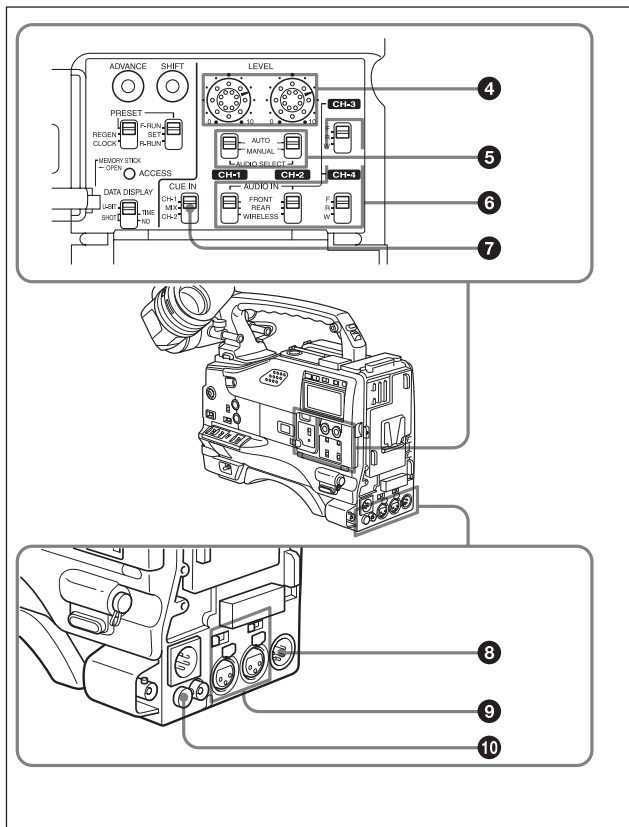

Audio functions (2)

4 LEVEL (CH-1/CH-2) (audio channel 1 and channel 2 recording level) controls

These controls adjust the audio levels of channels 1 and 2 when audio input is from the AUDIO IN CH-1/CH-2 connectors and the AUDIO SELECT switches are set to MANUAL.

5 AUDIO SELECT (CH-1/CH-2) (audio channel-1 and channel-2 adjustment method select) switches

These switches select the audio level adjustment method for each of audio channels 1 and 2.

AUTO: Select this setting for automatic adjustment.

MANUAL: Select this setting for manual adjustment.

6 AUDIO IN CH-1/CH-2 / CH-3/CH-4 (audio input select) switches

AUDIO IN CH-1/CH-2 switches

These switches select the audio input signals to be recorded for audio channels 1 and 2.

FRONT: The input signal source is the microphone connected to the MIC IN connector.

REAR: The input signal source is the audio equipment connected to the AUDIO IN CH-1/CH-2 connectors.

WIRELESS: The input signal source is a WRR-855A/855B UHF Synthesized Tuner Unit (not supplied).

CH-3/CH-4 switches

These switches select the audio input signals to be recorded for audio channels 3 and 4.

Note

To activate CH-3/CH-4 switches, set AUDIO CH3/4 MODE to SW on the VTR MODE 1 page of the MAINTENANCE menu.

F (FRONT): The input signal source is the microphone connected to the MIC IN connector.

R (REAR): The input signal source is the audio equipment connected to the AUDIO IN CH-1/CH-2 connectors.

W (WIRELESS): The input signal source is a WRR-855A/855B UHF Synthesized Tuner Unit (not supplied).

With the HDCA-901 (not supplied) connected to the camcorder, you can record separate sounds in audio channels 3 and 4.

For detailed information, see “When the HDCA-901 camera adaptor is used” on page 4-35.

7 CUE IN (cue track input) switch

This switch selects the input signal to be recorded on the cue track.

CH-1: Signal selected by the AUDIO IN CH-1 switch **6**

MIX: Mixed signals selected by the AUDIO IN CH-1 and CH-2 switches **6**

CH-2: Signal selected by the AUDIO IN CH-2 switch **6**

8 AUDIO OUT (audio output) connector (XLR type, 5-pin, male)

This connector outputs the audio signals recorded to audio channels 1 and 2 or audio channels 3 and 4.

The MONITOR CH-1/2 / CH-3/4 switches **13** allow you to select the audio signal to be played back.

Using a CCXA-53 Audio Cable (not supplied), you can convert from a 5-pin connection to two 3-pin connections.

9 AUDIO IN CH-1/CH-2 (audio channel 1 and channel 2 input) connectors (XLR type, 3-pin, female) and LINE/MIC/+48 V ON (line input/microphone input/external power supply +48 V ON) switches

These are audio input connectors for channels 1 and 2 to which you can connect audio equipment or a microphone.

The LINE/MIC/+48V ON switches select the audio source of the audio input signals connected to each of these connectors.

LINE: Line input audio equipment

MIC: Microphone with an internal power supply

+48V ON: Microphone with an external power supply system

10 DC OUT (DC power output) connector

This connector supplies power for a WRR-810A/860A/862A/862B UHF Portable Tuner (not supplied). Do not connect any equipment other than the UHF portable tuner.

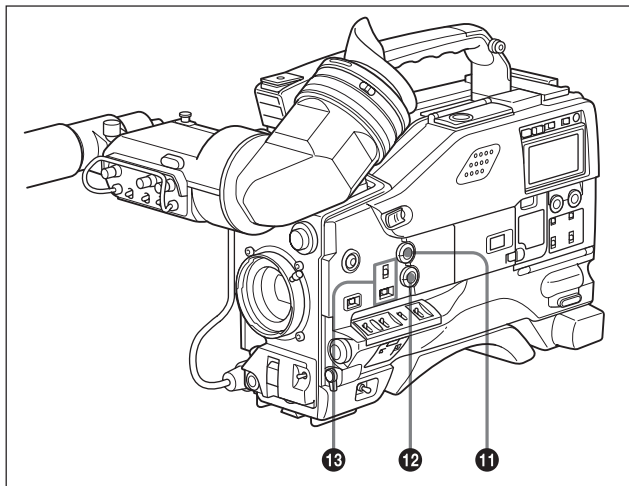

Audio functions (3)

11 ALARM volume control

This control adjusts the speaker or earphone alarm volume. At the minimum position, no sound can be heard.

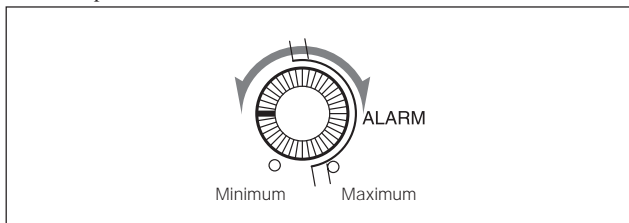

ALARM volume control

The internal volume control can be adjusted so that the alarm is audible even if the ALARM volume control is at the minimum position.

For more information, refer to the Maintenance Manual (not supplied).

12 MONITOR volume control

This control adjusts the speaker or earphone volume for sounds other than the alarm sound. At the minimum position, no sound can be heard.

13 MONITOR (audio channel select) switch /CH-1/2 / CH-3/4 (audio channel 1/2 / audio channel 3/4 select) switch

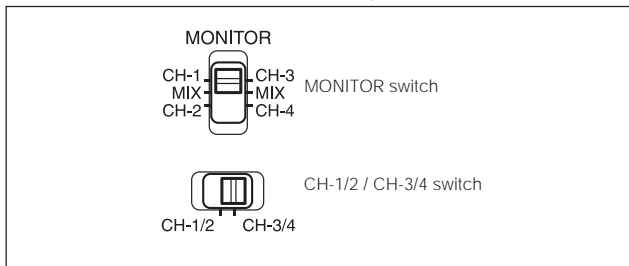

MONITOR switch and CH-1/2 / CH-3/4 switch

CH-1/2 / CH-3/4 switch

This switch decides the audio channel to be selected by the MONITOR switch.

CH-1/2: Audio channels 1 and 2

CH-3/4: Audio channels 3 and 4

The following settings depend on the CH-1/2 / CH-3/4 switch setting:

- The signal output to the AUDIO OUT connector ⑧ is switched.
 - CH-1/2: Audio channels 1 and 2
 - CH-3/4: Audio channels 3 and 4
- The audio signal indicated by the audio level meter in the display window is switched.

MONITOR switch

This switch selects the audio output to the speaker or earphone.

CH-1/2 position	CH-3/4 position	MONITOR switch position	Audio output
CH-1/2		CH-1	Audio channel 1
		MIX	Mix sound of channels 1 and 2
		CH-2	Audio channel 2
CH-3/4		CH-3	Audio channel 3
		MIX	Mix sound of channels 3 and 4
		CH-4	Audio channel 4

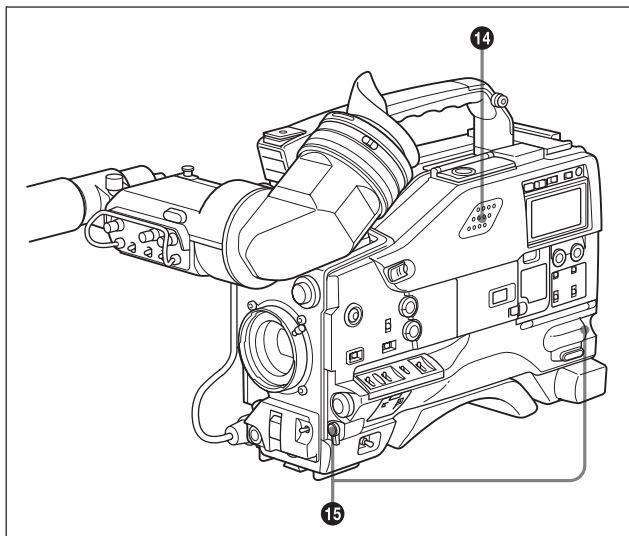

Audio functions (4)

14 Built-in speaker

During recording, the speaker can be used for monitoring the E-E¹⁾ sound, and during playback for monitoring playback sound. The speaker also sounds alarms to reinforce visual warnings.

If an earphone is plugged into the EARPHONE jack, the speaker sound is automatically cut off.

See “6-3 Operation Warnings” on page 6-14 for information about alarms.

1) E-E sound (Electric-to-Electric sound)

The term E-E sound refers to an audio signal that has passed through the amplifier, but has not been recorded on the tape. In other words, you can directly monitor the recording input signal, as opposed to the simultaneous playback (output) signal.

15 EARPHONE jacks (minijack)

You can monitor the E-E sound during recording and playback sound during playback. Plugging an earphone into the jack automatically cuts off the built-in speaker, and you hear the alarms about the camcorder's operation and status through the earphone.

The signals output from these jacks are the same. You can connect two earphones to these jacks at the same time.

2-4 Shooting and Recording/Playback Functions

2

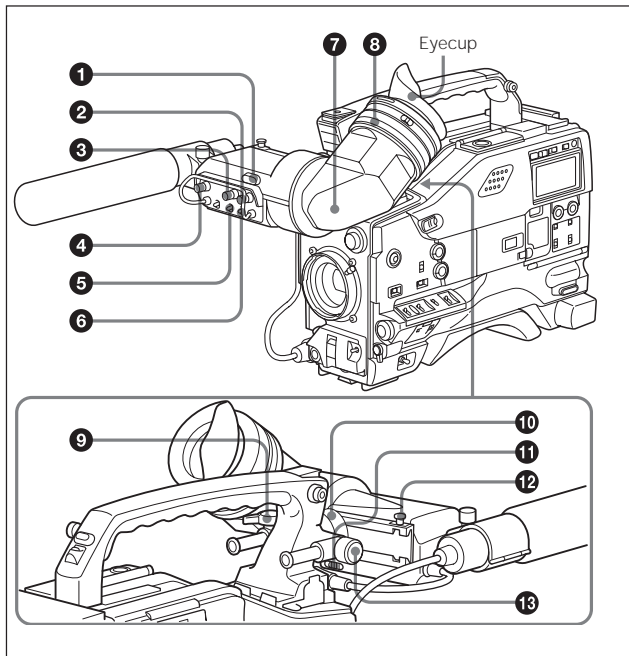

Shooting and recording/playback functions (1)

1 TALLY indicator

Setting the TALLY switch to HIGH or LOW activates this indicator. The indicator lights during recording on the VTR. It also provides the same information as the REC indicator in the viewfinder: it comes on during recording and flashes to indicate a problem.

② BRIGHT (brightness) control

This control adjusts the picture brightness on the viewfinder screen. It has no effect on the camera output signal.

③ CONTRAST control

This control adjusts the picture contrast on the viewfinder screen. It has no effect on the camera output signal.

④ PEAKING control

This control adjusts the sharpness of the picture on the viewfinder screen to make focusing easier. It has no effect on the camera output signal.

⑤ ZEBRA (zebra pattern) switch

This switch controls the zebra pattern on the viewfinder screen.

ON: The zebra pattern ¹⁾ is displayed and stays.

OFF: No zebra pattern is displayed.

MOMENT: The zebra pattern is displayed and stays for 5 to 6 seconds.

The zebra pattern is factory set to indicate picture areas where the video level is approximately 70%. The setup menu can be used to specify that areas where the video level is 100% and above are to be displayed at the same time.

For information about how to set the zebra pattern is to be displayed to indicate areas of 100% or more, see “4-7-5 Setting the Viewfinder” on page 4-78.

1) Zebra pattern

The zebra pattern aids in manual iris adjustment by indicating areas of the picture where the video level is approximately 70% and 100% and above.

6 TALLY switch

This switch controls the TALLY indicator, setting its brightness (HIGH or LOW) or turning it off.

HIGH: The TALLY indicator gets brighter.

OFF: The TALLY indicator does not operate.

LOW: The TALLY indicator gets dimmer.

7 Viewfinder

The viewfinder lets you to view the camera image in black and white while shooting the picture and also see the playback picture from the VTR. It also displays various warnings and messages related to the settings or operating conditions of the camcorder, a zebra pattern, safety zone marker¹⁾, and center marker²⁾.

Also, you can use the BVF-V20/V20CE black and white viewfinder with the 525i/625i method and BVF-VC10 color viewfinder.

8 Diopter adjustment ring

Use this ring to adjust the viewfinder image for your vision.

9 Viewfinder front-rear positioning lever

Locks the viewfinder together with the LOCK knob 13 after adjusting the front-rear positioning.

10 Viewfinder left-right positioning ring

Use this ring to move the viewfinder sideways.

1) Safety zone marker

The safety zone marker is a rectangle indicating the effective picture area.

For more information, see "4-7-4 Setting the Marker Display" on page 4-75.

2) Center marker

The center marker indicates the center of the picture with a crosshair.

11 Cameraman tally indicator

This indicator lights while the camcorder is operating.

Slide the window open when you shoot, keeping your eye away from the viewfinder. This indicator flashes when the battery level is running low or the tape is nearing its end.

12 Viewfinder stopper

Pull up this stopper to detach the viewfinder from the camera.

13 LOCK knob

Locks the viewfinder together with the Viewfinder front-rear positioning lever **9** after adjusting the front-rear positioning.

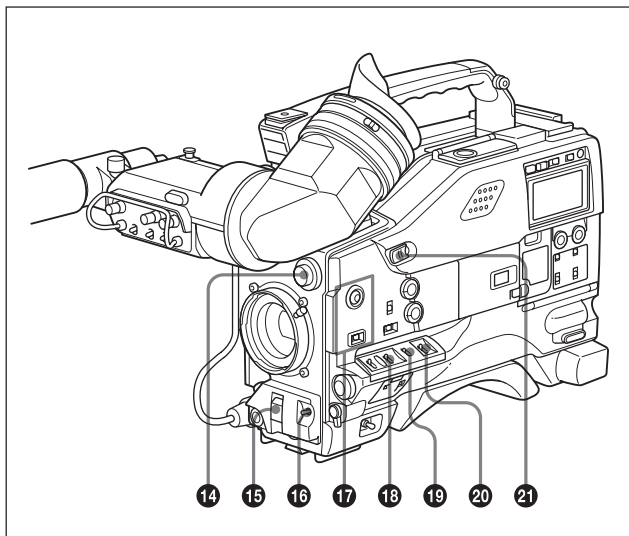

Shooting and recording/playback functions (2)

14 FILTER selector

This selector is a dual knob that selects the most appropriate filter to match the light source illuminating the subject. The outer knob selects the color temperature of the CC (Color Conversion) filter, and the inner knob selects the type of ND (Neutral Density) filter. The white balance is stored in memory for each CC filter.

Note that if the display mode is set to 3, when this selector is adjusted, the new setting will be indicated on the viewfinder screen for about 3 seconds. (e.g.: FILTER: 3)

For detailed information on the display mode, see “4-7-3 Display Mode and Setting Change and Adjustment Progress Messages” on page 4-73.

The relationships between the selector settings and filter selections as well as examples of filters for different shooting conditions are given below.

FILTER selector (outer) setting and CC filter selection

FILTER selector (outer) setting	CC filter selection
A	Cross filter ^{a)}
B	3200K
C	4300K
D	6300K

a) A type of special effect filter. Generates a cross-hair light ray on a highlighted portion.

FILTER selector (inner) setting and ND filter selection

FILTER selector (inner) setting	ND filter selection
1	Clear
2	1/4 ND
3	1/16 ND
4	1/64 ND

Examples of shooting conditions and appropriate filters

Shooting condition	CC filter	ND filter
Sunrise and sunset; inside studio	B (3200 K)	1 (clear)
Clear skies	C(4300 K) or D (6300 K)	2 (1/4 ND) or 3 (1/16 ND)
Cloudy or raining	D (6300 K)	1 (clear) or 2 (1/4 ND)
Very bright conditions such as snow, at high altitudes, or at the seashore	C (4300 K) or D (6300 K)	3 (1/16 ND) or 4 (1/64 ND)

15 SHUTTER selector

Set this selector to ON to use the electronic shutter. Set it to SEL to switch the shutter speed or mode setting within the range that has been previously set from the setup menu.

When this selector is adjusted, the new setting will be indicated on the setting change/adjustment progress message display area for about 3 seconds.

For more information about the shutter speed and mode settings, see “4-2 Setting the Electronic Shutter” on page 4-12.

16 AUTO W/B BAL (automatic white/black balance adjustment) switch

This switch activates the white balance and black balance automatic adjustment functions.

WHT: Automatic adjustment of the white balance. If the WHITE BAL switch is set to A or B, the white balance setting is stored in the corresponding memory. The memory can store the white balance setting for each CC filter.

BLK: Automatic adjustment of the black set and black balance.

17 ASSIGN (assignable) switches 1/2

You can assign the desired functions to each of ASSIGN 1 switch (push-type) and ASSIGN 2 switch (slide-type) on the FUNCTION 1 page of the USER menu.

For details, see “4-8-5 Assigning Functions to ASSIGN 1/2 Switches” on page 4-109.

18 GAIN selector

This selector switches the gain of the video amplifier to match the lighting conditions during shooting. The gains corresponding to the L, M, and H settings are selected from the setup menu before use. The factory settings are L = 0 dB, M = 6 dB, and H = 12 dB.

When this selector is adjusted, the new setting will be indicated on the

setting change/adjustment progress message display area of the viewfinder screen for about 3 seconds.

For information about setting the gain values, see “4-8-1 Setting the GAIN Selector Values” on page 4-98.

19 OUTPUT/DCC (output signal/dynamic contrast control) selector

This selector switches the video signal that is output to the VTR, viewfinder, and video monitor, between the color bar signal and the camera output.

BARS: Outputs the color bar signal.

CAM: Outputs the camera signal. It also switches DCC¹⁾ on and off when output from the camera is selected.

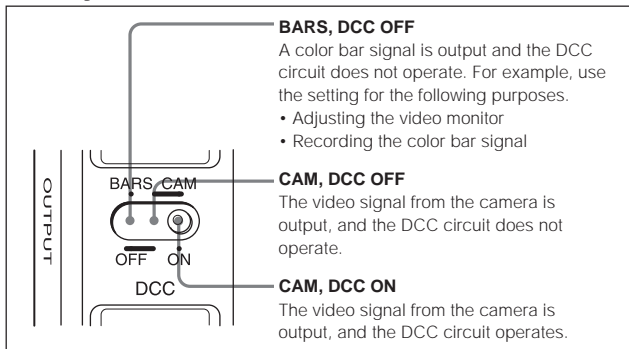

OUTPUT/DCC selector

1) DCC (Dynamic Contrast Control)

Also called automatic knee. Against a very bright background with the iris opening adjusted to the subject, objects in the background will be lost in the glare. The DCC function will suppress the high intensity and restore much of the lost detail and is particularly effective in the following cases.

- Shooting a subject against a bright sky
- Shooting a subject indoors, against a background through a window
- Any high contrast scenes

20 WHITE BAL (white balance memory) switch

This switch determines the source of the white balance settings.

PRST (preset): Adjusts the color temperature corresponding to the position of the FILTER selector (outer knob). Use the PRST setting when you have no time to adjust the white balance.

A or B: When the AUTO W/B BAL switch is pushed to WHT, the white balance is automatically adjusted according to the current position of the FILTER selector (outer knob), and the adjusted value is stored in either memory A or memory B. (There are two memories for each CC filter, so a total of eight adjustments can be stored.) When the FILTER selector (outer knob) is at the same position as it was when this WHITE BAL switch was adjusted, the stored value is called from memory, and the camcorder automatically adjusts itself to that value.

B (ATW): When this switch is set to B whereas, on the FUNCTION 2 page of the OPERATION menu, WHITE B CH is set to ATW¹⁾, the ATW is activated.

When this switch is adjusted, the new setting will be indicated on the setting change/adjustment progress message display area of the viewfinder screen for about 3 seconds.

You can assign the ATW ON/OFF function to the ASSIGN 1 switch (push-type) on the FUNCTION 1 page of the USER menu.

For details, see “4-8-5 Assigning Functions to ASSIGN 1/2 Switches” on page 4-109.

21 TURBO GAIN button

When shooting under extremely poor lighting conditions, slide the cover of this button to the left and press the button once to boost the video gain to the value preset on the GAIN SW page of the USER menu (up to 42 dB, factory setting: 42 dB). To stop boosting the gain, press the button once more.

1) ATW (Auto Tracing White Balance)

The white balance of the picture being shot is adjusted automatically for the varying lighting conditions.

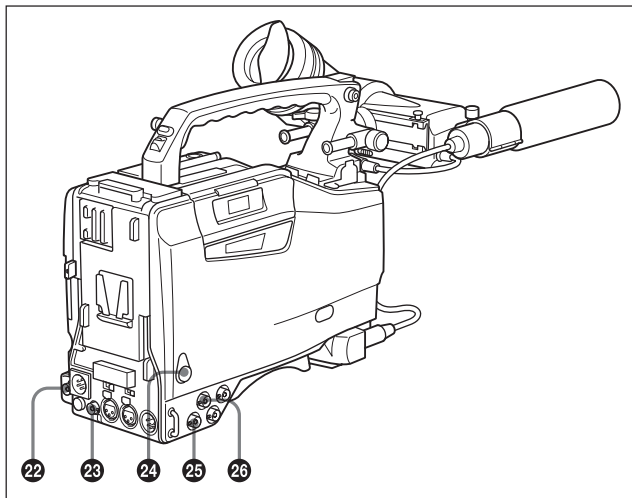

Shooting and recording/playback functions (3)

**22 VBS/SDI OUT (video signal output) connector (BNC type)
(Only when an HKDW-702 extension board (not supplied) is
installed)**

In this manual, the illustration of the camcorder which the BNC connector is attached is used. If you do not install an HKDW-702, ignore this connector.

This connector outputs down-converted 525i/625i signals (75-ohm terminated) to the video monitor. The output signal can be selected as analog composite or SDI. Refer to the FUNCTION 1 page of the USER menu. Selecting OFF stops the converter.

For instructions on how to select the output signal, see “4-8-2 Selecting the Output Signals” on page 4-101.

Note

- The down-converted signal (analog composite/SDI signals) is delayed by several milliseconds, compared with the video signal recorded on the tape.
- When an HKDW-702 is attached to an HDW-750/HDW-730 which operates with the 59.94I format, the HD signal is down-converted to the 525i signal. When an HKDW-702 is attached to an HDW-750P/HDW-730 with the 50I format, the HD signal is down-converted to the 625i signal.

23 HD SDI OUT (HD SDI output) connector (BNC type)

This connector outputs the HD SDI signal to the video monitor.

For instructions on how to select whether or not the signal is output from this connector (ON/OFF), refer to the OUTPUT SEL page of the USER menu.

For details, see “4-8-2 Selecting the Output Signals” on page 4-101.

24 REMOTE (remote control) connector (8-pin)

Connect the RM-B150 Remote Control Unit (not supplied), which makes VTR control possible.

25 TEST OUT (test output) connector (BNC type)

This connector outputs the HD-Y (black and white) signal.

When an HKDW-702 extension board (not supplied) is installed, the output signal can be selected as a down-converted analog composite (color) or HD-Y signal on the OUTPUT SEL page of the USER menu. Depending on the internal board and menu settings, the menu, time code, and shot data can be displayed over the image on the monitor. You can use this connector to synchronize the time code of an external VTR to the time code of the camcorder.

For instructions on how to select the test output signal when an HKDW-702 is installed, see “4-8-2 Selecting the Output Signals” on page 4-101.

26 GENLOCK IN (genlock input) connector (BNC type)

This connector inputs an HD reference signal when the camera is to be genlocked or when the time code is to be synchronized with external equipment. Use the MAINTENANCE menu to adjust the genlock H-phase (phase of Horizontal sync signal).

For details, refer to the Maintenance Manual (not supplied).

This connector also inputs the NTSC/PAL composite video signal as the reference signal when the time code is to be synchronized with external equipment. In this case, the genlock H-phase cannot be adjusted. Beyond that, the subcarrier of the down-converted signal (composite video signal) cannot be synchronized with external equipment when an HKDW-702 (not supplied) is installed.

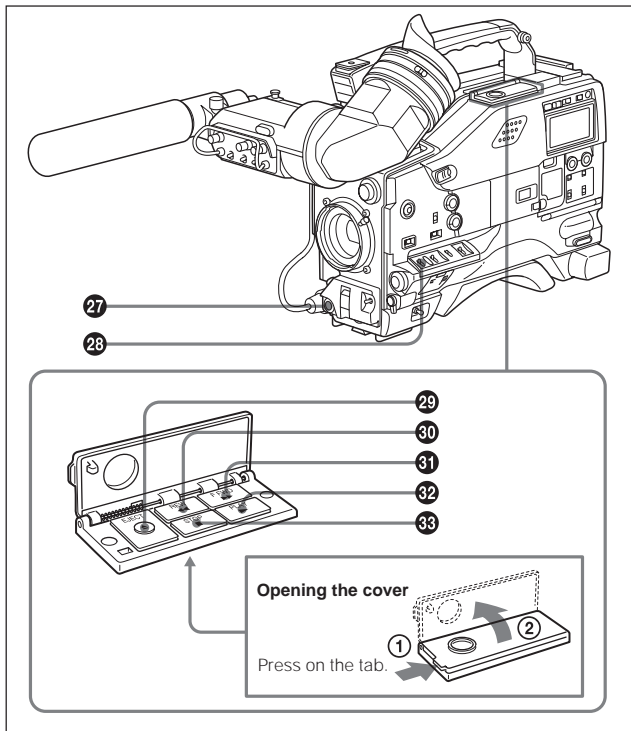

Shooting and recording/playback functions (4)

27 VTR START button

Press this button to start recording. Press it again to stop recording. The effect is exactly the same as that of the VTR button on the lens.

When the REC SWITCH function is assigned to the ASSIGN 1 (push type), you can use the ASSIGN 1 switch as the VTR START button.

28 VTR SAVE/STBY (VTR power saving/standby) switch

This switch controls the VTR power mode during pauses in recording (REC PAUSE).

SAVE: Power saving mode. When you press the VTR START button, there is a short delay before recording starts, but power consumption is less than in standby mode, and battery life is extended. When the switch is set to SAVE, the VTR SAVE indicator in the viewfinder lights.

STBY: Standby mode. Recording starts as soon as you press the VTR START button. Avoid allowing the camcorder to remain in STBY (standby) mode for a long time.

Note

Even if the switch is set to the STBY position, the camcorder can automatically turn to power saving mode when the tape does not run for a certain period. In such a case, the VTR SAVE indicator in the viewfinder lights.

This function is effective when a setting other than OFF is selected for the STILL TIMER item on the VTR MODE 4 page of the MAINTENANCE menu. The STILL TIMER item also allows you to select the time until the camcorder turns to power saving mode.

For detailed information, refer to the Maintenance Manual.

29 EJECT (cassette eject) button

Press this button to eject or load a cassette.

30 REW (rewind) button and indicator

Press this button to rewind the tape. The indicator lights during rewinding.

31 F FWD (fast forward) button and indicator

Press this button to fast forward the tape. The indicator lights during fast forward.

32 PLAY (playback) button and indicator

Press this button to view the recorded picture in the viewfinder or on the color video monitor. The indicator lights during playback.

The 4 times normal speed search function is provided to make it far quicker to find a desired location of the tape. Press the REW button or F FWD button during playback to view the 4 times normal speed search picture.

33 STOP button

Press this button to stop the tape.

2-5 Menu Operating Section

2

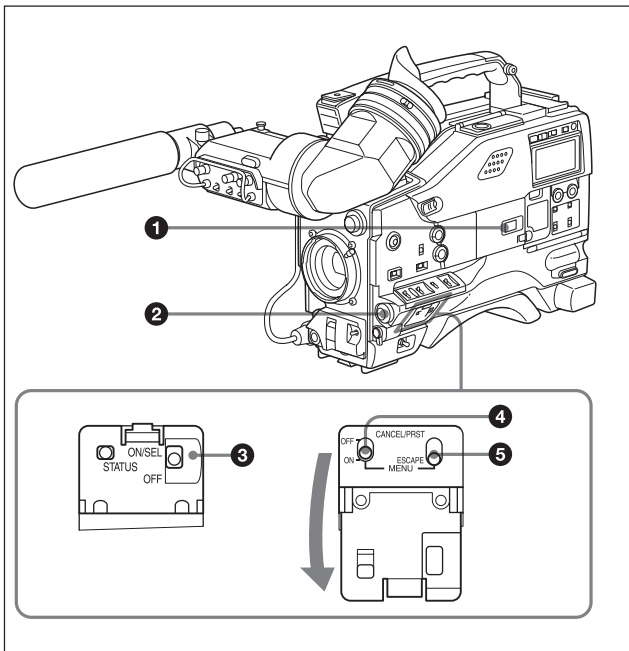

Menu operating section

1 Memory Stick compartment

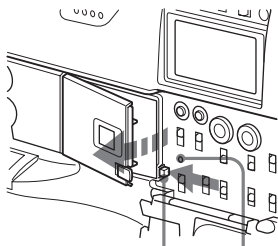

MEMORY STICK OPEN button ACCESS lamp

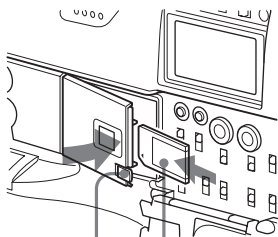

EJECT button

Memory Stick

Open the cover of the Memory Stick compartment by pressing the MEMORY STICK OPEN button. Insert the Memory Stick (not supplied) with the notch facing downward and the label facing toward you into the slot.

Note

Do not insert/remove a Memory Stick while the ACCESS lamp is lit or flashing. Doing so may damage the data.

② MENU knob

Use this knob to change the page selection or a setting within the menu.

Push: If you push this knob when the arrow (→) is placed at the page title on the menu, the arrow (→) changes to the question mark (?) and you can change the page.

When the arrow mark is placed at the position other than the page title, the camcorder turns in mode where you can change the settings by pushing this knob.

Turn: Turn this knob to change the page or change the settings of the items.

③ STATUS ON/SEL / OFF (menu display on/paging/display off) switch

To enable this switch, set the MENU ON/OFF switch to OFF.

Closing the cover automatically sets the MENU ON/OFF switch to OFF.

ON/SEL: Each time this switch is pushed upward, the window to confirm the menu settings and conditions of the camcorder is displayed on the viewfinder screen. There are three windows, which are switched each time the switch is pushed upward. Each window is displayed for about 10 seconds.

OFF: To clear the page immediately after display, push this switch down to the OFF position.

You can select the confirmation window to be displayed on the menu.

For details, see “Display/don’t display status confirmation windows” on page 4-92.

4 MENU ON/OFF (menu display) switch

To use this switch, open the cover.

This switch is used to display the menu on the viewfinder screen or the test signal screen. Closing the cover results in automatically setting this switch to OFF.

ON: Displays the menu on the viewfinder screen or the test signal screen, at the page which was on the screen when the previous menu access ended. (When the menu is first used, the first page is displayed.)

OFF: Removes the menu from the viewfinder screen or the test signal screen.

5 CANCEL/PRST / ESCAPE (menu setting cancellation/menu presetting/returning page) switch

To enable this switch, set the MENU ON/OFF switch to ON.

Closing the cover automatically sets the MENU ON/OFF switch to OFF.

CANCEL/PRST: Pushing this switch up to this position displays the message to confirm whether the previous settings are cancelled or settings are reset to their initial values, depending on the menu operating condition.

Pushing this switch up to this position again cancels the previous settings or resets the settings to their initial values.

ESCAPE: Use this switch when the menu page, which has a hierarchical structure, is opened. Each time the switch is pushed to this position, the page returns to one stage higher in the hierarchy.

2-6 Time Code System

2

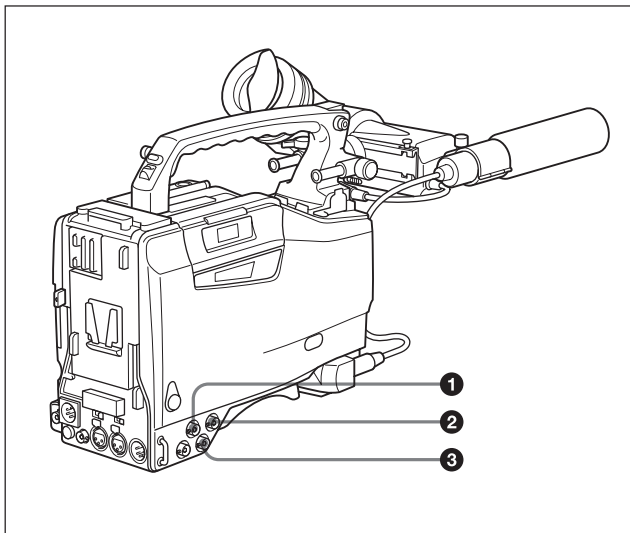

Time code functions (1)

❶ GENLOCK IN (genlock input) connector (BNC type)

- This connector inputs an HD reference signal when the camera is to be genlocked or when the time code is to be synchronized with external equipment.

This connector can input an NTSC/PAL analog composite signal as the reference video signal when the time code is to be synchronized with external equipment.

-
- This connector also inputs a return video signal. You can display the image of the return video signal in the viewfinder screen when you set the RETURN VIDEO to ON on the GENLOCK page of the OPERATION menu.

You can assign the RETURN VIDEO function to ASSIGN 1 switch.

For details, see “4-8-5 Assigning Functions to ASSIGN 1/2 Switches” on page 4-109.

② TC IN (time code input) connector (BNC type)

To synchronize the time code with an external time code, connect the reference time code input here.

③ TC OUT (time code output) connector (BNC type)

To synchronize the time code of an external VTR with that of the camcorder, connect this connector to the time code input lock connector of the external VTR.

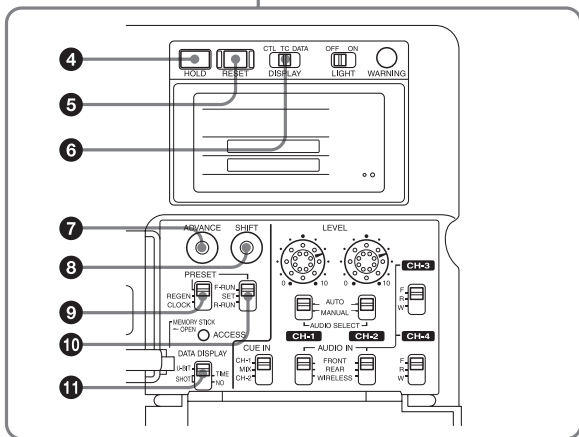
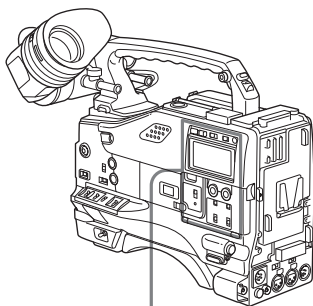

Time code functions (2)

4 HOLD (display hold) button

Pressing this button instantly freezes the time data displayed in the counter display section. (The time code generator continues normal operation.) Pressing this button again releases the hold. One use of this feature is to determine the exact time of a particular shot.

When the HOLD button is activated, the time data is displayed in the following format:

00:00:00:00

See “2-8 Warnings and Indications on the Display Panel” on page 2-42 for more information about the counter display.

5 RESET (counter reset) button

This button resets the time data displayed on the counter display section to “00:00:00:00” and the user bit data to “00000000”.

6 DISPLAY (LCD) switch

CTL: Control signal

TC: Time code

DATA: The item selected by the DATA DISPLAY switch.

For more information, see “Time code displays” on page 2-44.

7 ADVANCE button

For setting the time code, user bits, or real time, each press of this button increments the flashing digit selected by the SHIFT button.

8 SHIFT button

For setting the time code, user bits, or real time, this button selects the digit to be changed. The selected digit flashes.

9 PRESET/REGEN/CLOCK (preset/regeneration/clock) switch

This switch selects whether to set a new time code or to match the existing time code that had been recorded.

PRESET: Starts recording time code values on the tape from the newly set value.

REGEN: Reads the existing time code on the tape and sets the time code starting value accordingly. Thus, even when there is an indefinite break in recording, this setting ensures that time codes on the tape will be continuous. Regardless of the setting of the F-RUN/SET/R-RUN switch, the camcorder operates in R-RUN mode.

CLOCK: Makes the time code value coincide with the built-in clock. Regardless of the F-RUN/SET/R-RUN switch setting, the camcorder always operates in F-RUN mode.

For more information, see “To make the time code continuous” on page 4-37.

10 F-RUN/SET/R-RUN (free run/set/recording run) switch

This switch selects the operating mode for the internal time code generator.

F-RUN: The time code generator keeps running, regardless of the operation state of the VTR. Use this position when matching the time code to real time or for synchronizing the time code with an external time code.

SET: Set the switch to this position to set the time code or user bits.

R-RUN: The time code generator runs only while recording. This produces a tape with consecutive time code value, even when shot intermittently.

For more information, see “4-5-3 Setting the User Bits” on page 4-38 and “4-5-1 Setting the Time Code” on page 4-35.

⑪ DATA DISPLAY switch

U-BIT: Display the user bit value.

SHOT-TIME: Display the date and time from the shot data.

SHOT-NO: Not used.

2-7 Warnings and Indications

The camcorder supplies you visual information and warnings by means of its indicators without you having to use the speaker, earphone or viewfinder.

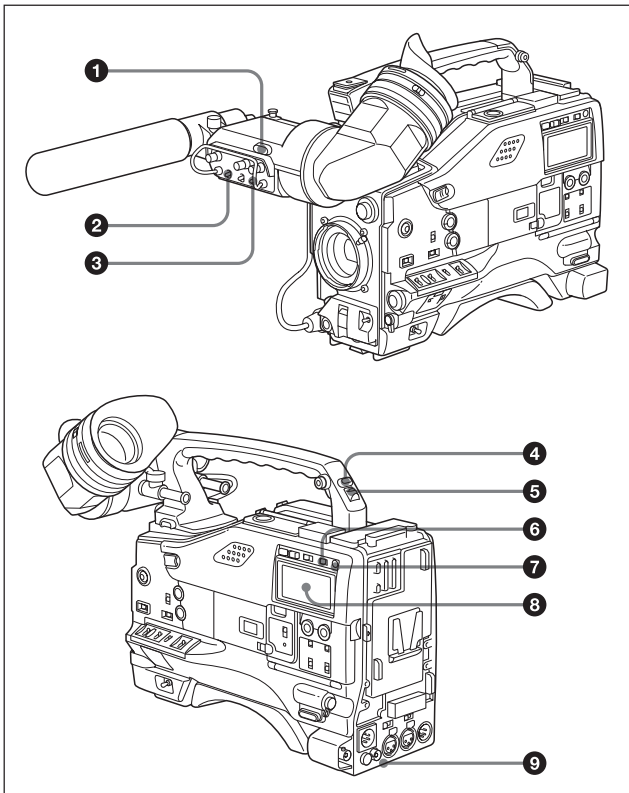

Warning and indication functions

❶ TALLY indicator

Setting the TALLY switch to HIGH or LOW activates this indicator. The indicator lights during recording on the VTR. It also provides the same information as the REC indicator in the viewfinder; it lights up during recording and flashes to indicate a problem. The brightness of this indicator when it is lit can be controlled by the TALLY switch.

❷ DISPLAY/ASPECT (display/aspect control) switch

Use this switch to turn the markers on or off and to change the viewfinder screen aspect ratio.

DISPLAY: When the MARKER is set to ON on the MARKER 1 page of the USER menu, pushing this switch to DISPLAY toggles the markers on the viewfinder screen on and off.

Even if the DISPLAY switch is set to OFF, the USER menu appears by setting the MENU ON/OFF switch is set to ON.

ASPECT: Pushing this switch to ASPECT toggles the viewfinder screen aspect ratio between 16 : 9 and 4 : 3.

For details, see “4-7-4 Setting the Marker Display” on page 4-75.

❸ TALLY switch

This switch controls the TALLY indicator, setting its brightness (HIGH or LOW) or turning it off.

HIGH: The TALLY indicator gets brighter.

OFF: The TALLY indicator does not operate.

LOW: The TALLY indicator gets dimmer.

❹ BACK TALLY indicator

This indicator is identical to the TALLY indicator ❶ when the BACK TALLY switch ❺ is set to ON. (This indicator may not work in the same manner as the TALLY indicator ❶ according to a certain condition.)

5 BACK TALLY switch

This switch turns the BACK TALLY and the REAR TALLY indicators on and off.

ON: Switches on the BACK TALLY and REAR TALLY indicators.

OFF: Switches off the BACK TALLY and REAR TALLY indicators.

6 LIGHT switch

This switch controls the display panel light.

ON: Turns the panel light on.

OFF: Turns the panel light off.

7 WARNING indicator

This indicator lights up or flashes when there is a fault in the VTR.

See “6-3 Operation Warnings” on page 6-14 for more information about the relationships between the operation of the indicator and the meanings of the indications.

8 Display panel

VTR error messages, battery status, tape status, audio level, time data, and so forth are displayed on this panel.

For more information, see “2-8 Warnings and Indications on the Display Panel” on page 2-42.

9 REAR TALLY indicator

This indicator is identical to the BACK TALLY indicator 4 when the BACK TALLY switch is set to ON.

2-8 Warnings and Indications on the Display Panel

Tape status, battery status, and level indicators

Audio channel level meter: When the CH-1/2 / CH-3/4 switch is set to CH-1/2, the audio channel level 1 is displayed.

When the CH-1/2 / CH-3/4 switch is set to CH-3/4, the audio channel level 3 is displayed.

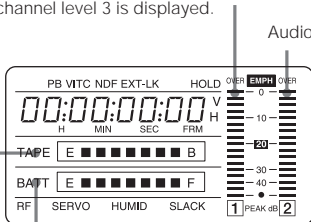

Audio channel level meter:

When the CH-1/2 / CH-3/4 switch is set to CH-1/2, the audio channel level 2 is displayed.

When the CH-1/2 / CH-3/4 switch is set to CH-3/4, the audio channel level 4 is displayed.

Battery status indicator



Fully charged

Nearly dead: "BATT" flashes.

Dead battery (battery must be charged):
"BATT" and "E" flash.

Tape status indicator



Full (at beginning)

Close to end: "TAPE" flashes.

End (tape must be replaced):
"TAPE" and "E" flash.

Tape status, battery status, and level indicators

VTR operation and status indicators

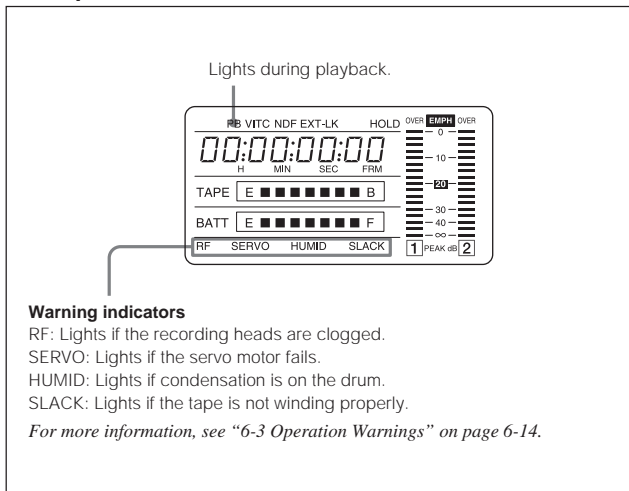

Warning indicators

RF: Lights if the recording heads are clogged.

SERVO: Lights if the servo motor fails.

HUMID: Lights if condensation is on the drum.

SLACK: Lights if the tape is not winding properly.

For more information, see “6-3 Operation Warnings” on page 6-14.

VTR operation and status indicators

Note

If the tape in the VTR becomes slackened, an error code appears automatically on the display section of the display panel.

For more information refer to the Maintenance Manual.

Time code displays

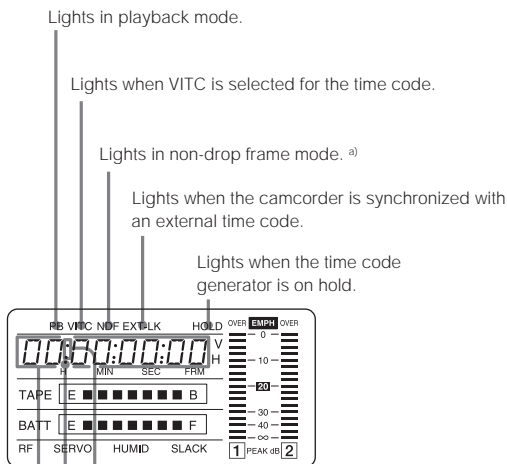

Lights in playback mode.

Lights when VITC is selected for the time code.

Lights in non-drop frame mode. ^{a)}

Lights when the camcorder is synchronized with an external time code.

Lights when the time code generator is on hold.

Lights when the time code, CTL, or real time is displayed.

Lights in the following way when the HOLD button is pressed.

00:00:00:00

Time counter display: Shows the time code, CTL, user bits, and real time.

The table on the next page lists the details of the displayed items and switch settings.

- a) Only for an HDW-750/HDW-730 which operates with the 59.94i format

Time code displays

Relationships between the DISPLAY switch and DATA DISPLAY switch settings and the time counter displays

Except during setting of the time code, the time counter display is determined by the position of the DISPLAY switch and DATA DISPLAY switch.

For details of setting the time code menu operation, see “4-5-1 Setting the Time Code” on page 4-35.

Switch settings related to time code and displayed information

DISPLAY switch position	DATA DISPLAY switch position	Displayed information
CTL	Any position	CTL
TC	Any position	Time code
DATA	U-BIT	User bits
	SHOT-TIME	Data and time from shot data
	SHOT-NO	Not used. (currently zero is displayed)

2-9 Indicators on the Viewfinder

2

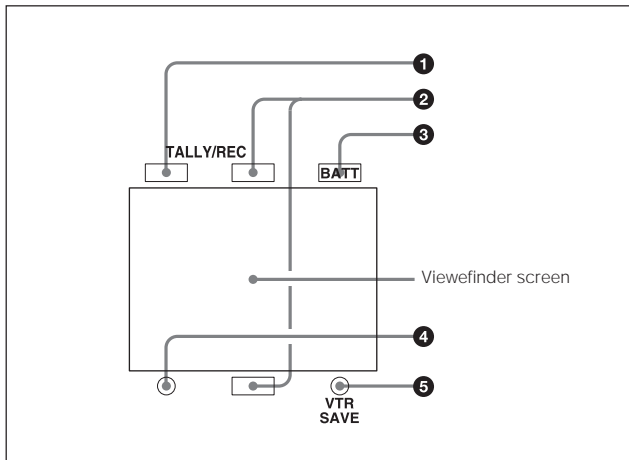

Indicators on the Viewfinder

❶ TALLY indicator

This indicator lights in green when the camcorder is in Loop Rec mode. Also, this indicator blinks in green when the camcorder is in auto Interval Rec mode or manual Interval Rec mode.

❷ REC (recording) indicator

This indicator lights in red during recording. It also warns by flashing. For more information, see “6-3 Operation Warnings” on page 6-14.

③ BATT (battery) indicator

This indicator starts flashing when the battery connected to the camcorder has fallen, and stays lit when the battery is exhausted. To prevent interruption during operation, replace the battery as soon as this indicator starts flashing.

The level at which the indicator starts flashing can be set on the BATTERY page of the MAINTENANCE menu.

For details, see the Maintenance Manual.

④ ! (warning) indicator

This indicator lights up when the camcorder is used under one or more of the following conditions and if the corresponding items have been set to ON on the '!' LED page of the USER menu.

- The gain is set to anything but 0 dB.
- The SHUTTER selector is ON.
- The WHITE BAL switch is set to PRST.
- ATW is being used.
- The lens extender is used.
- The FILTER selector is set to anything but ND:1/CC:A.
- The reference value of the auto iris adjustment is anything but the standard value.

Note

For an HDW-750P which operates with the 25PsF format, this indicator functions as follows.

For the 1/50 shutter speed, this indicator does not light even when the SHUTTER selector is set to ON.

For a shutter speed other than 1/50, this indicator lights up when the SHUTTER selector is set to ON.

⑤ VTR SAVE indicator

Lights up when the VTR section is set to power save mode by setting the VTR SAVE/STBY switch to SAVE.

3-1 About Cassettes

This section describes the procedure for loading and unloading a cassette.

See “Specifications VTR Section ”(page A-3) for information about the cassettes you can use in the camcorder.

3-1-1 Loading and Unloading a Cassette

Loading a cassette

- 1 Turn on the POWER switch.

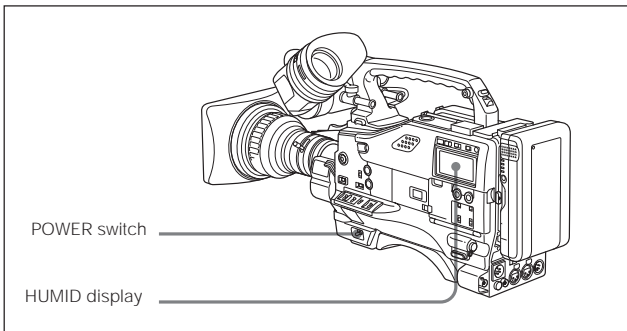

Note

If the interior of the VTR section is damp, the HUMID indicator will light. If this happens, wait until the indicator goes off before going on to step 2.

(Continued)

- 2** Press the EJECT button.
The cassette lid will open.

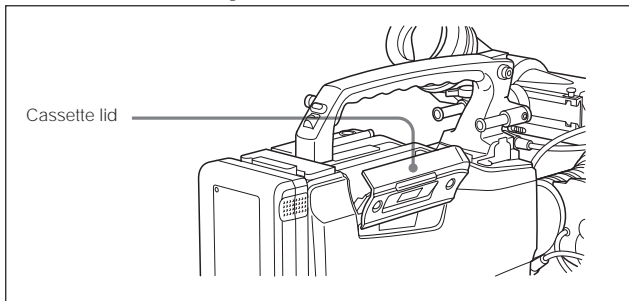

- 3** Check that there is no slack in the tape. Then slide in the cassette until it clicks into position and close the cassette lid completely by pressing near the engraved “PUSH”.

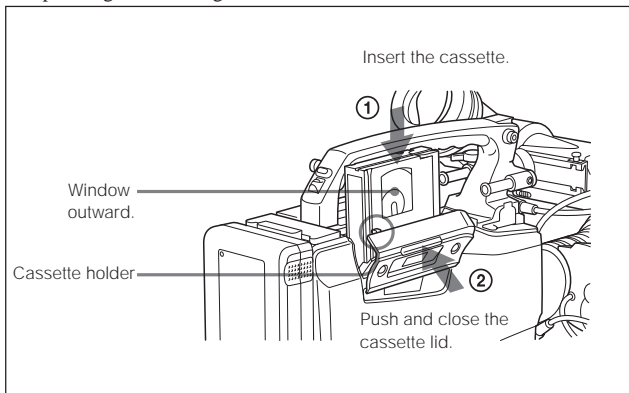

Notes

- To insert the tape correctly, make sure to stand the grip of the camcorder.
- When inserting the tape, be careful that you don't hit the tape against the tape holder.

Checking the tape for slack

Pressing in the reels lightly, turn them gently with your fingers in the directions shown below. If the reels will not move, there is no slack.

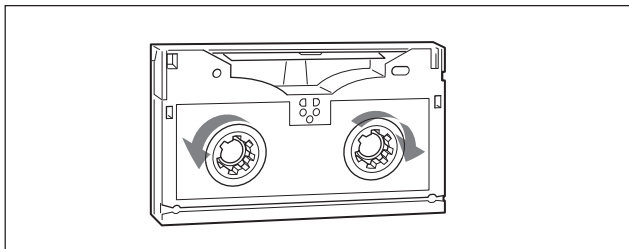

Checking the tape for slack

Unloading a cassette

With the power supply on, press the EJECT button to open the cassette lid. Then take out the cassette. If you are not going to insert another cassette, close the cassette lid.

It is possible to take out the cassette and close the cassette lid unless the battery voltage drops below about 10.5 V. Do not repeat this unloading operation.

Unloading a cassette manually

If the battery voltage drops below about 10.5 V, take out the cassette manually as illustrated below.

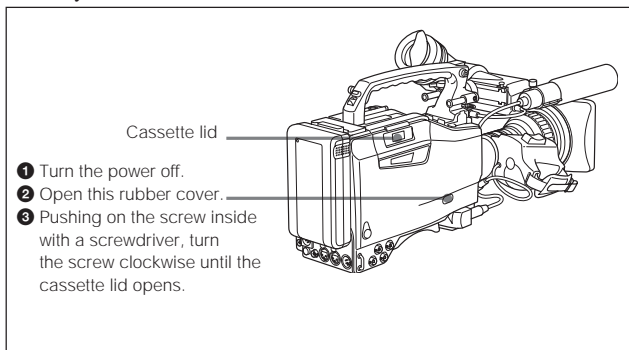

Unloading a cassette manually

You need not return the screw to its original position after taking out the cassette. Although the cassette lid is not locked, turning on the power makes the cassette lid operable again.

3-1-2 Preventing Accidental Erasure

The following procedure prevents cassettes from being recorded inadvertently.

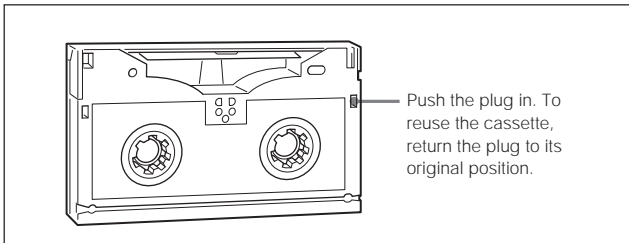

Preventing accidental erasure

3-2 Recording

3-2-1 Basic Procedures

This section describes the basic procedures for shooting and recording. Before a shooting session, ensure that the camcorder is functioning properly.

For more information, see “6-1 Testing the Camcorder Before Shooting” on page 6-1.

Turning on the camcorder and loading a cassette

Follow the procedure below.

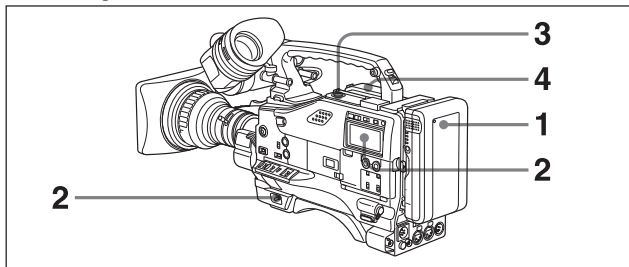

Basic procedure for shooting : from power supply to cassette loading

1 Attach a fully charged battery pack.

For details, see “5-1 Power Supply” on page 5-1.

-
- 2** Set the POWER switch to ON. Check that warnings, such as the HUMID indicator and so on, do not appear and that the BATT indicator shows at least five segments.

- If HUMID indicator appears, wait until it disappears.

Note

After turning off the power, check whether the drum is dry (even if the HUMID indicator is off) when the turning on the power again.

- If the BATT indicator does not show at least five segments, replace the battery pack with a fully charged one.

For detailed information on warnings, see “6-3 Operation Warnings” on page 6-14.

- 3** Check that there are no obstructions near the cassette lid. Then press the EJECT button to open the cassette lid.

- 4** After checking the points below, load the cassette and close the cassette lid.

- The cassette is not write-protected.
- There is no slack in the tape.

Basic procedures for shooting: from adjusting the black balance and white balance to stopping recording

After turning on the power and loading a cassette, set the switches and selectors as shown below and begin operation.

3

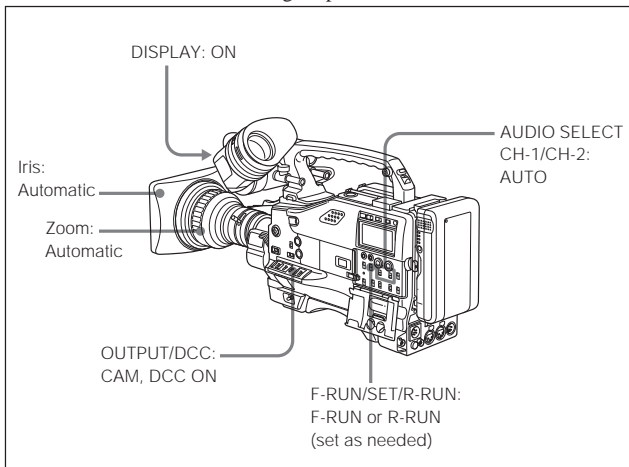

Switch and selector settings before shooting

Shooting

Follow the procedure below.

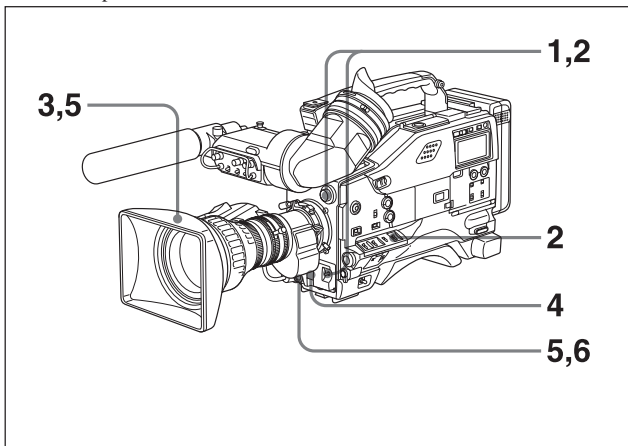

Basic procedure for shooting: from adjusting the black balance and white balance to stopping recording

- 1** Push the AUTO W/B BAL switch to BLK to adjust the black balance.

For detailed information on how to adjust the black balance, see “4-1-1 Adjusting the Black Balance” on page 4-2.

(Continued)

-
- 2** Select the CC filter and ND filter to match the lighting conditions, and adjust the white balance.

When the black balance and white balance settings are already in memory:

Set the WHITE BAL switch to A or B.

When the white balance setting is not in memory and you do not have enough time to adjust the white balance:

Set the WHITE BAL switch to the PRST position. The white balance is automatically set to 3200 K when the FILTER selector is set to B, to 4300 K when the FILTER selector is set to C, and to 6300 K when the FILTER selector is set to D.

For more information, see “4-1-2 Adjusting the White Balance” on page 4-6.

- 3** Aim the camera at the subject and adjust the focus and zoom.
- 4** If necessary, set the electronic shutter for an appropriate mode and speed.

For more information, see “4-2 Setting the Electronic Shutter” on page 4-12.

- 5** To start recording, press the VTR START button or the VTR button on the lens.

Or if the REC BUTTON function is assigned to the ASSIGN 1 switch, this switch functions as VTR START/STOP buttons.

For details, see “4-8-5 Assigning Functions to ASSIGN 1/2 Switches” on page 4-109.

During recording, the REC indicator in the viewfinder goes on. Perform zooming and focus control, if necessary.

-
- 6** To stop recording, press the VTR START button or the VTR button on the lens again.

The REC indicator in the viewfinder goes off.

Cassette control buttons

During recording, the cassette control buttons (EJECT, REW, F FWD, PLAY, STOP) have no effect.

Note on cassettes

When crash-recording without doing continuous recording or recording by using RE-TAKE function, if you use a recorded tape, the timecode previously recorded may be displayed for a few seconds, even though the new video and audio signals have been correctly recorded.

3-2-2 Continuous Recording

If the camcorder is in the recording pause mode, simply pressing the VTR START button on the camcorder or the VTR button on the lens continues recording at exactly the next frame.

In other cases, you first need to position the tape at an appropriate point.

3

When the camcorder is in the recording pause mode

Pressing the VTR START button on the camcorder or the VTR button on the lens positions the tape at the appropriate point automatically.

However, the time taken before recording starts depends on the setting of the VTR SAVE/STBY switch.

- If the VTR SAVE/STBY switch is in the SAVE position, it takes about 4 seconds before recording starts.
- If the VTR SAVE/STBY switch is in the STBY position, recording starts immediately. However, just after the switch position is changed from SAVE to STBY, it takes about 4 seconds before recording starts.

If you turn off the power during a recording pause

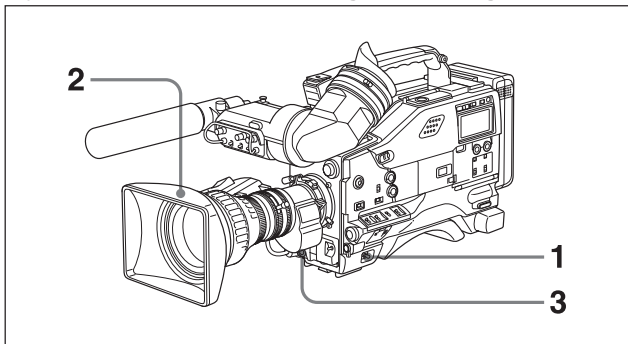

Continuous recording after turning off the power during a recording pause

- 1** Turn on the power again.
- 2** Press the RET button on the lens.

The camcorder positions the tape at the appropriate point. Note, however, that this function works only for continuously recorded material or consecutively joined segments totaling at least 3 seconds in length.

- 3** Press the VTR START button on the camcorder or the VTR button on the lens to start recording.

Continuous recording in other cases

After rewinding or fast forward, after removing the cassette, or on a tape that has been partially recorded, you can obtain a continuous recording by following the procedure below.

The End Search function also allows you to continue recording on the partially recorded tape.

For details, see “3-2-8 Searching for the Last Recorded Portion and Turning in the Recording Pause Mode (End Search Function)” on page 3-53.

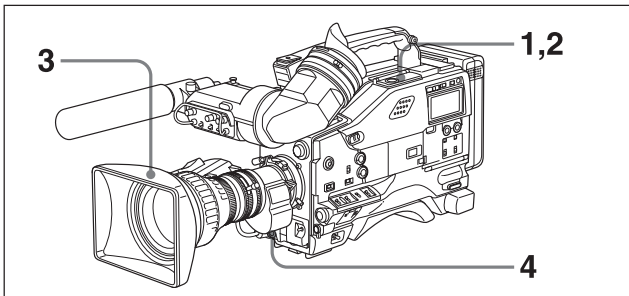

Continuous recording after rewinding or fast forward, after removing the cassette, or on a tape that has been partly recorded

- 1** Looking in the viewfinder, press the PLAY button to start playback.
- 2** Press the STOP button at the desired point to begin recording. To continue from the end of recording already on the tape, press the STOP button immediately after the end of the previous recording (within 0.5 seconds).
- 3** Press the RET button.

The tape will rewind and will be positioned at the desired point to continue recording.

- 4** Press the VTR START button on the camcorder or the VTR button on the lens to start recording.

3-2-3 Recording Good Shot Markers

Good shot markers 1 and 2 are recorded to tape when the RET button on the lens is pressed during recording. Recording shot markers ¹⁾ 1 and 2 for scenes containing important images and sounds enables quick access to the marked points. This increases editing efficiency.

For detailed information on shot marker operations, refer to the manual supplied with your VTR.

A setting on the VTR MODE 5 page of the MAINTENANCE menu determines whether or not good shot markers are recorded to the tape.

Recording markers to the tape

Follow the procedures below to perform settings for recording markers.

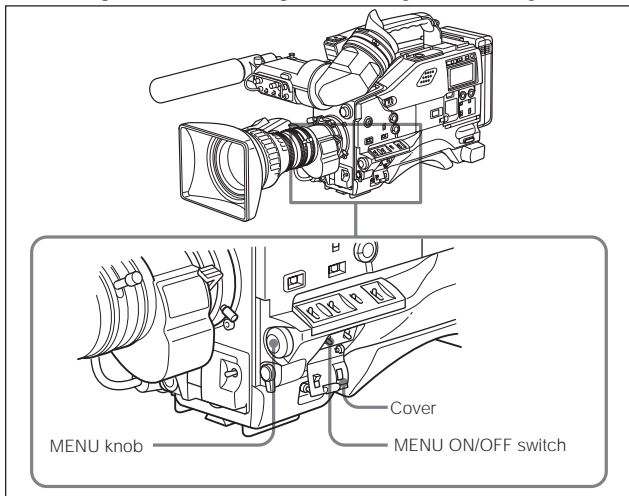

.....
1) Shot marker

Time code of the scene to be used as the editing point when editing.

-
- 1 Open the cover, first. Set the MENU ON/OFF switch to ON while pushing the MENU knob .

The TOP menu appears.

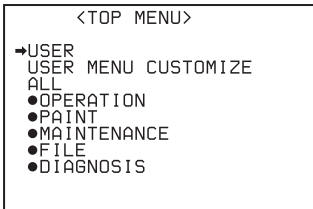

- 2 Turn the MENU knob to move the → mark to MAINTENANCE.
- 3 Push the MENU knob.

When the MAINTENANCE menu is first used, the CONTENTS page appears.

Or if you have used the MAINTENANCE menu already, the page that was on the screen when the last MAINTENANCE menu operation ended appears on the viewfinder screen.

- 4** When the CONTENTS page is displayed, turn the MENU knob to move the → mark to VTR MODE 5, then push the MENU knob. When any page of the MAINTENANCE menu is displayed, turn the MENU knob until the VTR MODE 5 page appears, then push the MENU knob.

The VTR MODE 5 page appears.

```
? 100VTR MODE-5
LTC UB-MARKER      : SET
REC START MARK    : OFF
SHOT MARKER 1     : OFF
SHOT MARKER 2     : OFF

SHOT TIME DISP    : MD:HM
```

- 5** Turn the MENU knob to move the → mark to LTC UB-MARKER.

```
S100VTR MODE-5
→LTC UB-MARKER    : ● SET
REC START MARK    : OFF
SHOT MARKER 1     : OFF
SHOT MARKER 2     : OFF

SHOT TIME DISP    : MD:HM
```

- 6** Push the MENU knob.

The → mark at the left of LTC UB-MARKER changes to a ● mark and the ● mark at the left of the setting changes to a ? mark.

(Continued)

-
- 7** Turn the MENU knob clockwise or counterclockwise until the desired setting appears.

The setting changes in the following sequence: SET ↔ ALL ↔ OFF.

3

```
S100VTR MODE-5
●LTC UB-MARKER   :?  SET
REC START MARK  :   OFF
SHOT MARKER 1   :   OFF
SHOT MARKER 2   :   OFF

SHOT TIME DISP  : MD:HM
```

Item	Contents
SET	Determines whether or not markers are recorded for the items REC START MARK, SHOT MARKER 1 and SHOT MARKER 2 which appear when you select SET.
ALL	Records the recording start markers, good shot marker 1 and good shot maker 2.
OFF	Does not record any markers.

When you select SET, go to step 8.

When you select ALL or OFF, go to step 9.

- 8** Set the marker(s) to be recorded to ON.

- ① Turn the MENU knob to move the → mark to the marker to be set.

S100VTR MODE-5			
LTC UB-MARKER	:	SET	
●REC START MARK	:	? OFF	
SHOT MARKER 1	:	OFF	
SHOT MARKER 2	:	OFF	
SHOT TIME DISP	:	MD:HM	

- ② Turn the MENU knob clockwise or counter clockwise until the desired setting appears.
To record the marker to the tape, select ON.
To not record the marker, select OFF.
- ③ Push the MENU knob.
- ④ Perform settings of the remaining markers repeating steps ①, ② and ③.

- 9 To end the menu operation, set the MENU ON/OFF switch to OFF, or close the cover.

The menu disappears from the viewfinder screen and the display indicating the current status of the camcorder appears along the top and bottom of the viewfinder.

Recording a shot marker 1

Press the RET button once. On the viewfinder screen, “●” and the time code of the marked point are displayed for about 3 seconds.

Recording a shot marker 2

Press the RET button twice. On the viewfinder screen, “X” and the time code of the marked point are displayed for about 3 seconds.

3-2-4 Recording a Recording Start Marker

You can record a recording start marker at the beginning of the recording.

Using recording start markers enables quick access to the marked points, for efficient editing.

For detailed information on recording start marker operations, refer to the manual supplied with your VTR.

You can set whether or not recording start markers are recorded using the VTR MODE 5 page of the MAINTENANCE menu.

For detailed information on setting whether or not recording start markers are recorded, see "Recording markers to the tape" on page 3-15.

3-2-5 Starting a Shoot with a Few Seconds of Pre-Stored Picture Data (Loop Rec Function) (When Using an HKDW-703 Extension Board)

By installing the optional HKDW-703 extension board (not supplied) in the camcorder, the camcorder is able to constantly store a few seconds (up to 7 seconds for the 59.94I format model or up to 8 seconds for the 50I/25PsF format model) worth of the most current picture and sound data in the board's memory.

Thus, when you press the VTR START button or the VTR button on the lens, the recording starts with the data stored a few seconds before.

Setting the Loop Rec time/Loop Rec mode

To record in Loop Rec mode, you need to turn on Loop Rec mode and set the picture data storage time (Loop Rec time) using the USER menu.

Loop Rec time

The Loop Rec time and VTR SAVE/STBY switch settings determine the number of seconds of picture data that will be stored in the HKDW-703's memory and recorded when you press the VTR START button or VTR button on the lens.

The following table shows the approximate number of seconds worth of picture data (counting back from the time you begin recording) that will be recorded from memory. However, when changing from SAVE to STBY, or under the special situations explained in the notes on this page, the actual amount of data recorded may be shorter.

Loop Rec time setting and recording start point

Loop Rec time	VTR STBY mode	VTR SAVE mode
7 (seconds) (for 59.94I format)	About 7 seconds before	About 4 seconds before
8 (seconds) (for 50I/25PsF format)	About 8 seconds before	About 5 seconds before
6 (seconds)	About 6 seconds before	About 4 seconds before (for 59.94I format) About 5 seconds before (for 50I/25PsF format)
5 (seconds)	About 5 seconds before	About 4 seconds before (for 59.94I format) About 5 seconds before (for 50I/25PsF format)
4 (seconds)	About 4 seconds before	About 4 seconds before
3 (seconds)	About 3 seconds before	About 3 seconds before
2 (seconds)	About 2 seconds before	About 2 seconds before
1 (seconds)	About 1 seconds before	About 1 seconds before
0 (seconds)	About 0 seconds before	About 0 seconds before

Notes

- After selecting the Loop Rec mode, immediately changing the Loop Rec time or performing playback or recording review, the picture data stored in memory before this operation are made to be unrecordable. This means that when you press the VTR START button or VTR button on the lens, the previously stored picture data will not be recorded.

- During playback or recording review, the picture data is not stored in the HKDW-703's memory. Picture data corresponding to the duration of playback or recording review will not be in memory and will not be recorded to tape.

3

To set the Loop Rec mode

Follow the procedure below to turn Loop Rec mode on.

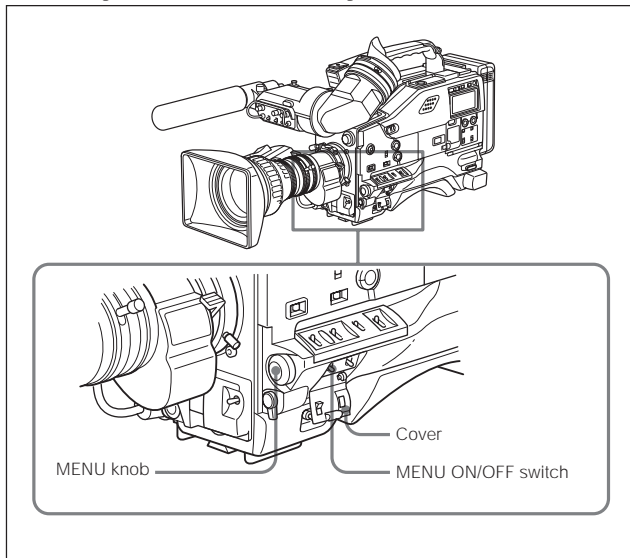

Switches to be used for settings

- 1** Open the cover, first. Set the MENU ON/OFF switch to ON.

The page that was on the viewfinder screen when the last menu operation ended will appear again.

2 Turn the MENU knob until the FUNCTION 1 page appears.

When the question mark appears at the left of the title page, you can switch the pages. Turn the MENU knob clockwise or counterclockwise to display the desired page.

```

? 02OFUNCTION1
  ASSIGN SW <1>      : EZ-FC
  ASSIGN SW <2>      : F.MIC
  →FRONT MIC SELECT : ● MONO
  DF/NDF             : DF
  END SEARCH         : OFF
  LOOP/INTVAL REC   : OFF
  
```

The DF/NDF item on the FUNCTION 1 page appears only for a camcorder which operate with the 59.94i format, that is, HDW-750 and HDW-730 which operates with the 59.94i format. In this manual, menu operation is explained using the menus of a camcorder which operates with the 59.94i format.

3 Push the MENU knob.

The → mark appears at the left of the currently selected item and the ● mark appears at the left of the setting.

```

02OFUNCTION1
  ASSIGN SW <1>      : EZ-FC
  ASSIGN SW <2>      : F.MIC
  →FRONT MIC SELECT : ● MONO
  DF/NDF             : DF
  END SEARCH         : OFF
  LOOP/INTVAL REC   : OFF
  
```

4 Turn the MENU knob to move the → mark to LOOP/INTVAL REC.

(Continued)

5 Push the MENU knob.

The → mark at the left of LOOP/INTVAL REC changes to a ● mark and the ● mark at the left of the setting changes to a ? mark.

3

```
02OFUNCTION1
ASSIGN SW <1> : EZ-FC
ASSIGN SW <2> : F.MIC
FRONT MIC SELECT: MONO
DF/NDF : DF
END SEARCH : OFF
●LOOP/INTVAL REC :? OFF
```

6 Turn the MENU knob clockwise or counterclockwise until LOOP appears.

If you turn the MENU knob clockwise or counterclockwise, the setting changes in the following sequence: OFF ↔ LOOP ↔ A. INT ↔ M. INT.

When LOOP appears, the camcorder is in the Loop Rec mode where picture, sound, and time code are constantly saved in memory. The TALLY lamp (green) is on while the picture data is being stored in the memory.

```
02OFUNCTION1
ASSIGN SW <1> : EZ-FC
ASSIGN SW <2> : F.MIC
FRONT MIC SELECT: MONO
DF/NDF : DF
END SEARCH : OFF
●LOOP/INTVAL REC :? LOOP
LOOP REC TIME : 0SEC
```

7 Push the MENU knob.

The ● mark at the left of LOOP/INTVAL REC changes to a → mark and the ? mark at the left of the setting changes to a ● mark. In this case, you can select another item.

8 Turn the MENU knob to move the → mark to LOOP REC TIME.

```

02OFUNCTION1
ASSIGN SW <1>   : EZ-FC
ASSIGN SW <2>   : F.MIC
FRONT MIC SELECT : MONO
DF/NDF         : DF
END SEARCH     : OFF

LOOP/INTVAL REC : LOOP
→LOOP REC TIME  : ● 0SEC
  
```

9 Push the MENU knob.

The → mark at the left of LOOP REC TIME changes to a ● mark and the ● mark at the left of the setting changes to a ? mark.

10 Turn the MENU knob clockwise or counterclockwise until the desired Loop Rec time appears.

If you turn the MENU knob clockwise or counterclockwise, the Loop Rec time changes in the following sequence: 0 SEC ↔ 1 SEC ↔ 2 SEC ↔ 3 SEC ↔ 4 SEC ↔ 5 SEC ↔ 6 SEC ↔ 7 SEC (for 59.94I) / 8 SEC (for 50 I).

(Continued)

11 Push the MENU knob.

The ● mark at the left of LOOP REC TIME changes to a → mark and the ? mark at the left of the setting changes to a ● mark.

3 12 To end the menu operation, set the MENU ON/OFF switch to OFF, or close the cover.

The menu disappears from the viewfinder screen and the display indicating the current status of the camcorder appears along the top and bottom of the viewfinder.

Settings made in Loop Rec mode are maintained until changed.

You can turn the Loop Rec mode on and off by pressing the ASSIGN 1/2 switch(es) to which the LOOP REC ON/OFF function is assigned.

For detailed information on the ASSIGN 1/2 switches, see “4-8-5 Assigning Functions to ASSIGN 1/2 Switches” on page 4-109.

Notes

- You can change the Loop Rec mode menu settings while recording; any changes that you make, however, do not take effect until after the recording operation is completed.
- When recording in Loop Rec mode, VITC is not recorded when the F-RUN/SET/R-RUN switch is set to R-RUN. When it is set to the F-RUN position, VITC is recorded.

Camcorder operations in Loop Rec mode

The recording procedure in Loop Rec mode is basically the same as that for normal recording. Please note, however, the following differences.

- When you record in Loop Rec mode, the picture you shoot is recorded to tape after the Loop Rec time elapses. For this reason, the tape does

not stop immediately when you press the VTR START button. After the VTR START button is pressed, all tape operation buttons (EJECT, REW, F FWD, PLAY, and STOP) stop functioning until the Loop Rec time has elapsed. During this time, if you press the VTR START button or VTR button on the lens, the recording starts again as if there were no pause in recording

- The time the tape stops after the VTR START button is pressed equals the Loop Rec time set. However, if you start recording within the set Loop Rec time immediately after selecting the Loop Rec mode, changing the Loop Rec time or performing playback or recording review, the picture data for the duration of the Loop Rec time will not be stored in memory. Thus, the time the tape stops after the VTR START button is pressed becomes shorter than the Loop Rec time.
- The time code stops advancing while time data is being set (when the F-RUN/SET/R-RUN switch is set to SET). For this reason, if you start recording immediately after switching to F-RUN or R-RUN (i.e., to a position other than SET), you may overwrite a portion of the previously recorded time code.

Turning off the camera

- When the power is turned off during recording, the camera will switch off by itself after the tape has run for a few seconds.
- If you remove the battery, pull out the DC cable, or cut power to the AC adaptor during recording, recording of picture data ends the instant the tape is stopped. The recorded picture data is interrupted before the recording stop point. For this reason, make sure you do not change the battery while recording.

When the tape runs out during recording

Please note that picture data at the instant the tape stopped is not recorded if the tape runs out and the camcorder stops. The recorded picture data is interrupted before the recording stop point.

3-2-6 Shooting Pictures at Intervals (Interval Rec Function) (When Using an HKDW-703)

Inserting an optional HKDW-703 extension board (not supplied) in the camcorder, enables the camcorder to record pictures intermittently.

There are two kinds of Interval Rec mode:

3

- Auto Interval Rec mode

In Auto Interval Rec mode, pictures are automatically shot a frame at a time at the specified interval and stored in memory. To use this function you must set the total time for shooting (TAKE TOTAL TIME) and the time to be recorded on the tape (REC TIME) on the FUNCTION 1 page of the USER menu.

- Manual Interval Rec mode

There are two kinds of Manual Interval Rec mode:

- Single trigger mode

Setting the number of frames to be recorded at one shooting (NUMBER OF FRAME) enables the camcorder to record the number of frames preset each time the VTR START button or the VTR button on the lens is pressed.

- Continuous trigger mode

Pictures are automatically shot by preset frames at preset intervals by pressing the VTR START button or the VTR button on the lens.

In the Auto Interval Rec and continuous trigger modes of the Manual Interval Rec mode, by setting the PRE-LIGHTING function to ON, the light connected to the LIGHT connector automatically turns on before recording starts. This allows you to record pictures under the stable light and color temperature conditions.

Setting the Auto Interval Rec mode

To record in Auto Interval Rec mode, you need to turn on Auto Interval Rec and set the total time from starting to finishing shooting (TAKE TOTAL TIME) and time to be recorded on the tape (REC TIME), using the USER menu.

Notes

- To make settings for Auto Interval Rec mode, set TAKE TOTAL TIME first, then REC TIME.
- To turn on the light automatically before starting recording by setting the PRE-LIGHTING item to ON, be sure to set the LIGHT switch to AUTO. Also, set the switch of the light connected to the LIGHT connector to on.

Follow the procedure below to turn on Auto Interval Rec mode

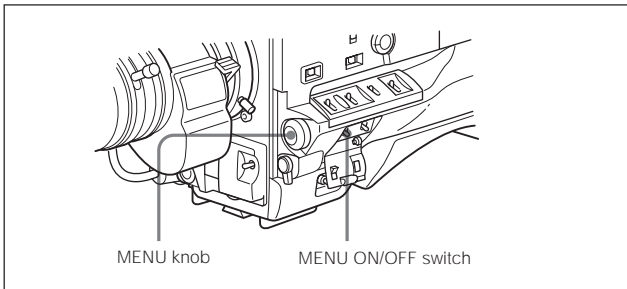

Switches to be used for setting the Auto Interval Rec mode

- 1 Set the MENU ON/OFF switch to ON.

The page that was on the viewfinder screen when the last menu operation ended will appear again.

(Continued)

2 Turn the MENU knob until the FUNCTION 1 page appears.

When a question mark appears at the left of the title page, you can switch the pages. Turn the MENU knob clockwise or counterclockwise to display the desired page.

```
? 02OFUNCTION1
ASSIGN SW <1> : EZ-FC
ASSIGN SW <2> : F.MIC
→FRONT MIC SELECT: ● MONO
DF/NDF       : DF
END SEARCH   : OFF

LOOP/INTVAL REC : OFF
```

The DF/NDF item on the FUNCTION 1 page appears only for a camcorder which operates with the 59.94I format, that is, HDW-750 and HDW-730 which operates with the 59.94I format. In this manual, menu operation is explained using the menus of a camcorder which operates with the 59.94I format.

3 Push the MENU knob.

The → mark appears at the left of the currently selected item and the ● mark appears at the left of the setting.

```
02OFUNCTION1
ASSIGN SW <1> : EZ-FC
ASSIGN SW <2> : F.MIC
→FRONT MIC SELECT: ● MONO
DF/NDF       : DF
END SEARCH   : OFF

LOOP/INTVAL REC : OFF
```

4 Turn the MENU knob to move the → mark to LOOP/INTVAL REC.

5 Push the MENU knob.

The → mark at the left of LOOP/INTVAL REC changes to a ● mark and the ● mark at the left of the setting changes to a ? mark.

```

02OFUNCTION1
ASSIGN SW <1>      : EZ-FC
ASSIGN SW <2>      : F.MIC
FRONT MIC SELECT  : MONO
DF/NDF           : DF
END SEARCH       : OFF
●LOOP/INTVAL REC :? OFF
  
```

6 Turn the MENU knob clockwise or counterclockwise until A. INT appears.

If you turn the MENU knob clockwise or counterclockwise, the setting changes in the following sequence: OFF ↔ LOOP ↔ A. INT ↔ M. INT.

When A. INT appears, the camcorder is in Auto Interval Rec mode. The TALLY indicator (green) flashes (one flash/second) while the camcorder is in this mode. Also, TAKE TOTAL TIME, REC TIME and PRE-LIGHTING appear.

```

02OFUNCTION1
ASSIGN SW <1>      : EZ-FC
ASSIGN SW <2>      : F.MIC
FRONT MIC SELECT  : MONO
DF/NDF           : DF
END SEARCH       : OFF
●LOOP/INTVAL REC :?A.INT
TAKE TOTAL TIME  : 5M
REC TIME         : 5SEC
PRE-LIGHTING     : OFF
  
```

(Continued)

7 Push the MENU knob.

The ● mark at the left of LOOP/INTVAL REC changes to a → mark and the ? mark at the left of the setting changes to a ● mark. In this case, you can select another item.

8 Turn the MENU knob to move the → mark to TAKE TOTAL TIME.

```
02OFUNCTION1
ASSIGN SW <1>      : EZ-FC
ASSIGN SW <2>      : F.MIC
FRONT MIC SELECT  : MONO
DF/NDFF           : DF
END SEARCH        : OFF

LOOP/INTVAL REC   : A.INT
→TAKE TOTAL TIME  : ● 5M
REC TIME          : 5SEC
PRE-LIGHTING      : OFF
```

9 Push the MENU knob.

The → mark at the left of TAKE TOTAL TIME changes to a ● mark and the ● mark at the left of the setting changes to a ? mark.

10 Turn the MENU knob clockwise or counterclockwise until the desired TAKE TOTAL TIME appears.

If you turn the MENU knob clockwise or counterclockwise, TAKE TOTAL TIME changes in the following sequence: 5M ↔ 10M ↔ 15M ↔ 20M ↔ 30M ↔ 40M ↔ 50M ↔ 1H ↔ 2H ↔ 3H ↔ 4H ↔ 5H ↔ 7H ↔ 10H ↔ 15H ↔ 20H ↔ 30H ↔ 40H ↔ 50H ↔ 70H ↔ 100H.

where M means minutes (5M is 5 minutes) and H means hours (1H is one hour).

11 Push the MENU knob.

The ? mark at the left of setting changes to a ● mark and the ● mark at the left of TAKE TOTAL TIME changes to a → mark.

12 Turn the MENU knob to move the → mark to REC TIME.

```

02OFUNCTION1
ASSIGN SW <1>      : EZ-FC
ASSIGN SW <2>      : F.MIC
FRONT MIC SELECT: MONO
DF/NDF            : DF
END SEARCH        : OFF

LOOP/INTVAL REC  : A.INT
TAKE TOTAL TIME  : 20H
→REC TIME        : ● 5SEC
PRE-LIGHTING     : OFF
  
```

13 Push the MENU knob.

The → mark at the left of REC TIME changes to a ● mark and the ● mark at the left of the setting changes to a ? mark.

14 Turn the MENU knob clockwise or counterclockwise until the desired time to be recorded on the tape appears.

If you turn the MENU knob clockwise or counterclockwise, REC TIME changes in the following sequence: 5 SEC ↔ 10SEC ↔ 15SEC ↔ 20SEC ↔ 30SEC ↔ 40SEC ↔ 50SEC ↔ 1MIN ↔ 2MIN ↔38MIN ↔ 39MIN ↔ 40MIN (for 59.94I fomrat)/48MIN (for 50I format).

where SEC means seconds (5SEC is 5 seconds) and MIN means minutes (1MIN is one minute).

(Continued)

You cannot set a REC TIME that is more than one thirtieth of TAKE TOTAL TIME.

For example: When TAKE TOTAL TIME is set to 1H, the maximum value of REC TIME is 2 MIN. (60 minutes divided by 30 gives 2 minutes.)

The time setting to be displayed when turning the MENU knob changes within the available setting times.

Be sure to set REC TIME after setting TAKE TOTAL TIME.

15 Push the MENU knob.

The ? mark at the left of setting changes to a ● mark and the ● mark at the left of TAKE TOTAL TIME changes to an → mark.

16 Turn the MENU knob to move the → mark to PRE-LIGHTING.

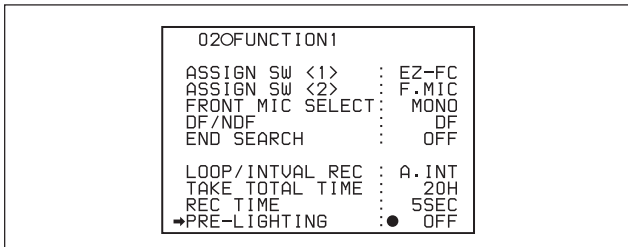

17 Push the MENU knob.

The → mark at the left of PRE-LIGHTING changes to a ● mark and the ● mark at the left of the setting changes to a ? mark.

18 Turn the MENU knob clockwise or counterclockwise until the desired time to turn on the light before starting recording appears.

If you turn the MENU knob clockwise or counterclockwise, the PRE-LIGHTING time changes in the following sequence: OFF ↔ 2SEC ↔ 5SEC ↔ 10SEC.

Notes

- To turn on the light automatically before starting recording by setting the PRE-LIGHTING item to ON, be sure to set the LIGHT switch to AUTO. Also, set the switch of the light connected to the LIGHT connector to on.
The light automatically turns on and off in Auto Interval Rec mode. However, if the duration when the light should be off is less than 5 seconds, the light is on continuously.
- When the LIGHT switch is set to MANUAL and the switch of the light is set to ON, the light is always on.

19 Push the MENU knob.

The ? mark at the left of setting changes to a ● mark and the ● mark at the left of PRE-LIGHTING changes to an → mark.

20 To end the menu operation, set the MENU ON/OFF switch to OFF, or close the cover of the menu operating section.

The menu disappears from the viewfinder screen and the message “AUTO INTERVAL **M**S” indicating Auto Interval Rec mode appears along the bottom of the viewfinder.

MS indicates the shooting interval. For example, when TAKE TOTAL TIME is set to 1H and REC TIME is set to 30 SEC, the message “AUTO INTERVAL 00M04S” appears. The shooting interval is 4 seconds.

The display indicating the current status of the camcorder appears along the top and bottom of the viewfinder.

Note

The settings for Auto Interval Rec mode are maintained until changed. However, if you switch off the camcorder power, Auto Interval Rec mode is cleared except for the TAKE TOTAL TIME, REC TIME and PRE-LIGHTING settings. To use the Auto Interval Rec function again after switching on the power, perform steps 1 to 6.

Camcorder operation in Auto Interval Rec mode

Follow the procedure below to shoot and record the picture in Auto Interval Rec mode after turning on Auto Interval Rec mode and making the required settings.

Note

When you use cassettes on which nothing is recorded, such as brand new cassettes, be sure to record color bars for more than 2 seconds at the beginning of a cassette.

- 1 After performing the basic procedures for shooting and recording, following the instructions in “3-2-1 Basic Procedures” (page 3-6), secure the camcorder so that it will not move.
- 2 Push the VTR START button on the camcorder or the VTR button on the lens.

The camcorder starts recording in Auto Interval Rec mode. When you use the PRE-LIGHTING function, the light turns on when you press the VTR START button. After the preset PRE-LIGHTING time has elapsed, the camcorder captures the picture. After the camcorder stores the picture data (for about five seconds) in memory, and actually records the stored picture data on the tape. Thus the tape runs intermittently. While recording in Auto Interval Rec mode, the TALLY indicator (green) in the viewfinder flashes (4 flashes/second) and the message “AUTO INTERVAL **M**S”

flashes in the viewfinder screen. When the camcorder is capturing the picture in the memory, the REC indicator (red) in the viewfinder lights.

After the time to be recorded on the tape (REC TIME) has elapsed, the camcorder automatically stops shooting and recording.

To continue auto interval recording

Press the VTR START button on the camcorder or the VTR button on the lens again.

The camcorder starts recording in Auto Interval Rec mode again.

To interrupt auto interval recording

Press the VTR START button or VTR button on the lens. The camcorder stops recording.

However, the tape may run to record picture data stored in memory until you interrupt Auto interval recording.

To end auto interval recording

You can clear Auto Interval Rec mode by the following two methods:

- Set the POWER switch to OFF.
- Set LOOP/INTVAL REC to OFF on the FUNCTION 1 page of the USER menu.

Time required for shooting and time required for recording on the tape

The Auto Interval Rec mode is effective for shooting objects that moves very slowly. You do, however, need to set the total time for shooting (TAKE TOTAL TIME) and the time for recording on the tape (REC TIME).

The time for shooting is the time required to shoot objects that moves very slowly. The camcorder stores the picture data a frame at a time as it is shot at the certain specified interval and records the picture data on tape when up to the picture data for about 5 seconds are stored in memory.

The time for recording on the tape is the length of recording the picture data shot during TAKE TOTAL TIME.

The camcorder calculates the shooting interval based on two set values: TAKE TOTAL TIME and REC TIME.

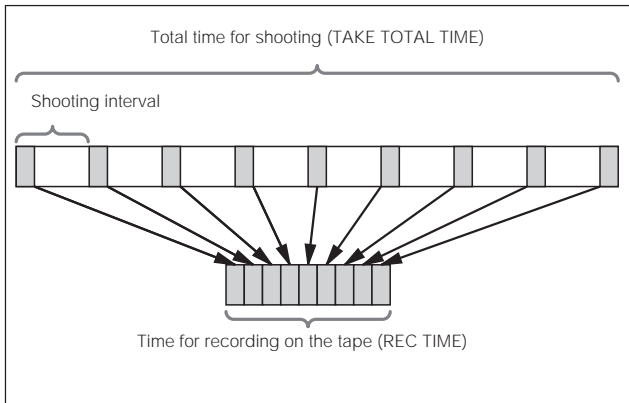

Notes on Auto Interval Rec mode

Take note of the following points.

• Time code

In Auto Interval Rec mode, the internal time code generator runs in R-RUN mode regardless of how the F-RUN/SET/R-RUN switch is set.

The real time of the shooting is saved in the user bits.

When you need to set the internal clock, use the TIME DATE page of the DIAGNOSIS menu.

For details, see “4-8-6 Setting the Date/Time of the Internal Clock” on page 4-114.

• Audio

The audio signal is not recorded in Auto Interval Rec mode.

• Cassette control buttons

While recording in Auto Interval Rec mode (the green tally indicator in the viewfinder flashes (4 flashes/second)), you cannot use cassette control buttons (EJECT, REW, F FWD, PLAY and STOP). To use the cassette control buttons, stop Auto interval recording by pressing the VTR START button or the VTR button on the lens.

• Menu operation

While recording in Auto Interval Rec mode (the green tally indicator in the viewfinder flashes (4 flashes/second)), you cannot change the settings of LOOP/INTVAL REC, TAKE TOTAL TIME and REC TIME. To change the settings, stop Auto interval recording by pressing the VTR START button or VTR button on the lens.

- **When the camcorder power is switched off during recording in Auto Interval Rec mode**
- When you set the POWER switch to OFF, the camcorder will switch off by itself after the tape has run for a few seconds to record the picture data stored in the memory.
- If you remove the battery, unplug the DC cable, or cut power to the AC adaptor while auto interval recording, the picture data shot and stored before recording stops (maximum 5 seconds) will not be recorded. Do not change the battery during auto interval recording.

- **When tape runs out during auto interval recording**

Note that the picture data (maximum 5 seconds) shot and stored before the tape stops is not recorded if the tape runs out and the camcorder stops.

Setting the Manual Interval Rec mode

There are two kinds of Manual Interval Rec mode:

- **Single trigger mode**
Setting the number of frames to be recorded at one shooting (NUMBER OF FRAME) enables the camcorder to record the number of frames preset each time the VTR START button or the VTR button on the lens is pressed.
- **Continuous trigger mode**
Pictures are automatically shot by preset frames at preset intervals by pressing the VTR START button or the VTR button on the lens.

Setting the single trigger mode

- 1 Follow the procedure in steps 1 to 5 in “Setting the Auto Interval Rec mode” on page 3-29 to select LOOP/INTVAL REC on the FUNCTION 1 page.

- 2** Turn the MENU knob clockwise or counterclockwise until M. INT appears.

```
02OFUNCTION1
ASSIGN SW <1> : EZ-FC
ASSIGN SW <2> : F.MIC
FRONT MIC SELECT: MONO
DF/NDF       : DF
END SEARCH   : OFF

●LOOP/INTVAL REC :?M.INT
NUMBER OF FRAME : 1
TRIGGER INTERVAL: 5MIN
PRE-LIGHTING    : OFF
```

If you turn the MENU knob clockwise or counterclockwise, the setting changes in the following sequence: OFF ↔ LOOP ↔ A. INT ↔ M. INT.

When M. INT appears, the camcorder turns in Manual Interval Rec mode and the TALLY indicator (green) flashes. NUMBER OF FRAME, TRIGGER INTERVAL and PRE-LIGHTING appear under LOOP/INTERVAL REC.

- 3** Push the MENU knob.

The ● mark at the left of LOOP/INTVAL REC changes to a → mark and the ? mark at the left of the setting changes to a ● mark. In this case, you can select another item.

(Continued)

- 4 Turn the MENU knob to move the → mark to NUMBER OF FRAME.

```
02OFUNCTION1
ASSIGN SW <1> : EZ-FC
ASSIGN SW <2> : F.MIC
FRONT MIC SELECT: MONO
DF/NDFF       : DF
END SEARCH    : OFF

LOOP/INTVAL REC : M. INT
→NUMBER OF FRAME : ● 1
TRIGGER INTERVAL: 5MIN
PRE-LIGHTING    : OFF
```

- 5 Push the MENU knob.

The → mark at the left of NUMBER OF FRAME changes to a ● mark and the ● mark at the left of the setting changes to a ? mark.

- 6 Turn the MENU knob clockwise or counterclockwise until the desired number of frames to be recorded at shooting appears.

If you turn the MENU knob clockwise or counterclockwise, the number changes in the following sequence: 1 ↔ 2 ↔ 4 ↔ 8.

- 7 Push the MENU knob.

The ? mark at the left of setting changes to a ● mark and the ● mark at the left of NUMBER OF FRAME changes to a → mark.

- 8** Turn the MENU knob to move the → mark to TRIGGER INTERVAL.

```

020FUNCTION1
ASSIGN SW <1>      : EZ-FC
ASSIGN SW <2>      : F.MIC
FRONT MIC SELECT  : MONO
DF/NDF            : DF
END SEARCH        : OFF

LOOP/INTVAL REC  : M.INT
NUMBER OF FRAME  : 8
→TRIGGER INTERVAL: ● 5MIN
PRE-LIGHTING     : OFF
  
```

- 9** Push the MENU knob.

The → mark at the left of TRIGGER INTERVAL changes to a ● mark and the ● mark at the left of the setting changes to a ? mark.

- 10** Turn the MENU knob clockwise or counterclockwise to display M.

If you turn the MENU knob clockwise or counterclockwise, the number changes in the following sequence: M ↔ 1SEC ↔ 2SEC.....12H ↔ 24H.

When M appears, the camcorder is in the single trigger mode of the Manual Interval Rec mode and PRE-LIGHTING disappears.

- 11** Push the MENU knob.

The ? mark at the left of setting changes to a ● mark and the ● mark at the left of TRIGGER INTERVAL changes to a → mark.

(Continued)

- 12** To end the menu operation, set the MENU ON/OFF switch to OFF or close the cover of the menu operating section.

The menu disappears from the viewfinder screen and the message “MANU INTERVAL *FRAME”, indicating the single trigger mode of the Manual Interval Rec mode, appears along the bottom of the viewfinder.

*FRAME indicates the number of frames set in step 6.

The display indicating the current status of the camcorder appears along the top and bottom of the viewfinder.

Note

The settings for the single trigger mode of the Manual Interval Rec mode are maintained until changed. However, if you switch the camcorder power off, Manual Interval Rec mode settings are cleared except for the NUMBER OF FRAME setting and the single trigger mode selection. To use the single trigger mode of the Manual Interval Rec function again after switching on the power, perform steps 1 to 2.

Camcorder operation in the single trigger mode of the Manual Interval Rec mode

Follow the procedure below to shoot a picture in the single trigger mode of the Manual Interval Rec mode.

Note

When you use cassettes on which nothing is recorded, such as brand new cassettes, be sure to record color bars for more than 2 seconds at the beginning of a cassette.

- 1** After performing the basic procedure for shooting and recording following the instructions in “3-2-1 Basic Procedures” (page 3-6), secure the camcorder so that it will not move.

- 2 Push the VTR START button on the camcorder or the VTR button on the lens.

The camcorder starts recording in the single trigger mode of the Manual Interval Rec mode. The TALLY indicator (green) in the viewfinder flashes (2 flashes/second) and the message “MANU INTERVAL *FRAME” flashes on the viewfinder screen.

Each time you press the VTR START button or VTR button, the camcorder captures and stores the picture data of the preset number of frames. The REC indicator (red) is on while the camcorder is capturing the picture in the memory. The camcorder stores picture data (for about 5 seconds) in memory, and actually records the stored picture data on the tape. The tape runs intermittently.

To stop the recording in the single trigger mode

You can stop the recording in the single trigger mode of the Manual Rec Interval mode using the following two methods. However, the tape may continue to run to record the picture data stored in the memory at the instant the tape stopped.

- Press the EJECT button.
- Set the POWER switch to OFF.

Setting the continuous trigger mode

- 1 Follow the procedure in steps 1 to 9 in “Setting the single trigger mode” on page 3-40.

(Continued)

- 2** Turn the MENU knob clockwise or counterclockwise to display the desired trigger interval.

3

```
020FUNCTION1
ASSIGN SW <1> : EZ-FC
ASSIGN SW <2> : F.MIC
FRONT MIC SELECT: MONO
DF/NDF       : DF
END SEARCH   : OFF

LOOP/INTVAL REC : M.INT
NUMBER OF FRAME : 2
● TRIGGER INTERVAL: ? 1SEC
PRE-LIGHTING   : OFF
```

If you turn the MENU knob clockwise or counterclockwise, the number changes in the following sequence: M ↔ 1SEC ↔ 2SEC ↔ 3SEC ↔ 4SEC ↔ 5SEC ↔ 6SEC ↔ 7SEC ↔ 8SEC ↔ 9SEC ↔ 10SEC ↔ 15SEC ↔ 20SEC ↔ 30SEC ↔ 40SEC ↔ 50SEC ↔ 1MIN ↔ 2MIN ↔ 3MIN ↔ 4MIN ↔ 5MIN ↔ 6MIN ↔ 7MIN ↔ 8MIN ↔ 9MIN ↔ 10MIN ↔ 15MIN ↔ 20MIN ↔ 30MIN ↔ 40MIN ↔ 50MIN ↔ 1H ↔ 2H ↔ 3H ↔ 4H ↔ 5H ↔ 6H ↔ 12H ↔ 24H.

When a trigger interval time other than M is displayed, the camcorder is in continuous trigger mode of the Manual Interval Rec mode. The TALLY indicator (green) flashes (1 flash/second).

- 3** Push the MENU knob.

The ? mark at the left of setting changes to a ● mark and the ● mark at the left of TRIGGER INTERVAL changes to a → mark.

- 4 Turn the MENU knob to move the → mark to PRE-LIGHTING.

```

02OFUNCTION1
ASSIGN SW <1>      : EZ-FC
ASSIGN SW <2>      : F.MIC
FRONT MIC SELECT: MONO
DF/NDF            : DF
END SEARCH        : OFF

LOOP/INTVAL REC  : M.INT
NUMBER OF FRAME  : 2
TRIGGER INTERVAL: 1SEC
→PRE-LIGHTING   : ● OFF
  
```

- 5 Push the MENU knob.

The → mark at the left of PRE-LIGHTING changes to a ● mark and the ● mark at the left of the setting changes to a ? mark.

- 6 Turn the MENU knob clockwise or counterclockwise until the desired time interval to turn on the light before recording starts appears.

If you turn the MENU knob clockwise or counterclockwise, the PRE-LIGHTING time changes in the following sequence: OFF ↔ 2SEC ↔ 5SEC ↔ 10SEC.

Notes

- To turn on the light automatically before recording starts by setting the PRE-LIGHTING item to ON, be sure to set the LIGHT switch to AUTO. Also, set the switch of the light connected to the LIGHT connector to ON.

The light automatically turns on and off in the continuous trigger mode of the Manual Interval Rec mode. However, if the duration when the light should be off is less than 5 seconds, the light is on continuously.

(Continued)

-
- When the LIGHT switch is set to MANUAL and the switch of the light is set to ON, the light is always on.

7 Push the MENU knob.

The ? mark at the left of setting changes to a ● mark and the ● mark at the left of PRE-LIGHTING changes to a → mark.

8 To end the menu operation, set the MENU ON/OFF switch to OFF or close the cover of the menu operating section.

The menu disappears from the viewfinder screen and the message “INTERVAL *SEC *FRAME”, indicating the continuous trigger mode of the Manual Interval Rec mode, appears along the bottom of the viewfinder.

*SEC indicates the trigger interval preset and *FRAME indicates the number of frames preset.

The display indicating the current status of the camcorder appears along the top and bottom of the viewfinder.

Note

The settings for the continuous trigger mode of the Manual Interval Rec mode are maintained until changed. However, if you switch the camcorder power off, Manual Interval Rec mode settings are cleared except for the NUMBER OF FRAME, TRIGGER INTERVAL, and PRE-LIGHTING settings. To use the continuous trigger mode of the Manual Interval Rec function again after switching on the power, perform steps 1 to 2 in “Setting the single trigger mode” on page 3-40.

Camcorder operation in the continuous trigger mode of the Manual Interval Rec mode

Follow the procedure below to shoot pictures in the continuous trigger mode of the Manual Interval Rec mode.

Note

When you use cassettes on which nothing is recorded, such as brand new cassettes, be sure to record color bars for more than 2 seconds at the beginning of a cassette.

- 1 After performing the basic procedures for shooting and recording following the instructions in “3-2-1 Basic Procedures”, (page 3-6), secure the camcorder so that it will not move.
- 2 Push the VTR START button on the camcorder or the VTR button on the lens.

The camcorder starts recording in the continuous trigger mode of the Manual Interval Rec mode, and the flashing cycle of the TALLY indicator (green) changes from 1 flash/second to 4 flashes/second, and the message “INTERVAL *SEC *FRAME” flashes on the viewfinder screen.

After you press the VTR START button or VTR button, the camcorder stores preset number of frames at the preset trigger intervals. However, when you use the PRE-LIGHTING function, the light turns on when you press the VTR START button. After the preset PRE-LIGHTING time has elapsed, the camcorder captures the picture in the memory. The camcorder stores picture data (for about 5 seconds) in memory, and actually records the stored picture data on the tape. Thus, the tape runs intermittently. The REC indicator (red) is on while the camcorder is capturing the picture in the memory.

To stop the recording in the continuous trigger mode of the Manual Interval Rec mode

You can stop the recording in the continuous trigger mode of the Manual Interval Rec mode using the following two methods. However, the tape may continue to run to record the picture data stored in the memory at the instant the tape stopped .

- Press the VTR START button or the VTR button on the lens.
- Set the POWER switch to OFF.

Notes on Manual Interval Rec mode

Take note of the following points which are common to the single trigger mode and continuous trigger mode. Any differences are clearly noted, if any.

• Time code

In Manual Interval Rec mode, the internal time code generator runs in R-RUN mode regardless of how the F-RUN/SET/R-RUN switch is set. Also, in the continuous trigger mode of the Manual Interval Rec mode, the real time of the shooting is saved in the user bits.

• Audio

The audio signal is not recorded in Manual Interval Rec mode.

• Cassette control buttons

While recording in the single trigger mode of the Manual Interval Rec mode (the green tally flashes (2 flashes/second)), you cannot use cassette control buttons (REW, F FWD, PLAY and STOP). Note that the camcorder stops recording in the single trigger mode of the Manual Interval Rec mode, if you press the EJECT button.

While recording in the continuous trigger mode of the Manual Interval Rec mode, you cannot use cassette control buttons (EJECT, REW, F FWD, PLAY and STOP). To stop recording, press the VTR START button or the VTR button on the lens.

However, the tape may run to record the picture data stored in the memory before stopping the manual interval recording.

- **Menu operation**

In the single trigger mode of the Manual Interval Rec mode, you cannot change the settings of LOOP/INTVAL REC and NUMBER OF FRAME on the FUNCTION 1 page after the camcorder starts recording. To change the settings, stop the recording pressing the EJECT button or setting the POWER switch to OFF.

In the continuous trigger mode the Manual Interval Rec mode, you cannot change the settings of LOOP/INTVAL REC, NUMBER OF FRAME and TRIGGER INTERVAL after the camcorder starts recording. To change the settings, stop the recording pressing the VTR START button or VTR button on the lens or setting the POWER switch to OFF.

- **When the camcorder power is switched off during recording in Manual Interval Rec mode**

- When you set the POWER switch to OFF, the camcorder will switch off by itself after the tape has run for a few seconds to record the picture data stored in the memory.
- If you remove the battery, unplug the DC cable, or cut the power to the AC adaptor while manual interval recording, the image currently being shot on the camcorder (maximum 5 seconds) will not be recorded. Do not change the battery while recording in Manual Interval Rec mode.

- **When tape runs out during recording in Manual Interval Rec mode**

Note that the picture data (maximum 5 seconds) at the instant the tape stopped is not recorded if the tape runs out and the camcorder stops.

3-2-7 Continuous Recording on the Previous Cut

By assigning the RE-TAKE function to the ASSIGN 1 switch, you can use the ASSIGN 1 switch to position the tape at the most recent cut, clear it and record the new cut.

For detailed information, see “4-8-5 Assigning Functions to ASSIGN 1/2 Switches” on page 4-109.

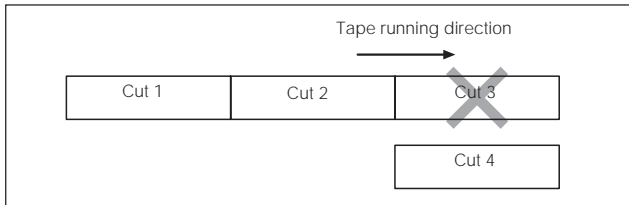

Example: After recording cut 3, clearing cut 3 and recording cut 4 after cut 2

Continuous recording of a new cut after the cut before the most recent cut

In the above example, with the camcorder in the recording pause mode after recording cut 3, press the RET switch on the lens while holding the ASSIGN 1 switch down.

The camcorder automatically positions the tape at the end point of cut 2 and changes to the recording pause mode.

Record cut 4. Cut 4 is recorded after cut 2.

Notes

- When pictures consisting of cuts recorded using the RE-TAKE function are played back by the VTR for professional use, the CHANNEL CONDITION indicator, which indicates the condition of the played back signal of the VTR, may be lit in yellow or noise may be added to the cue audio for the first 2 or 3 seconds. To avoid this, it is recommended that you make the first part of the cut (in the above example, cut 4) about 3 seconds longer.

- If you use a recorded tape, the timecode previously recorded may be displayed, even though the new picture and audio are correctly recorded.

3-2-8 Searching for the Last Recorded Portion and Turning in the Recording Pause Mode (End Search Function)

The End Search Function allows the camcorder to search for the end of the recording on the tape after the recorded portion is rewound and played back.

To use this function, set the END SEARCH function to ON on the FUNCTION 1 page of the USER menu.

For detailed information on menu operation, see “4-6-2 Basic Use of the Menu” on page 4-49.

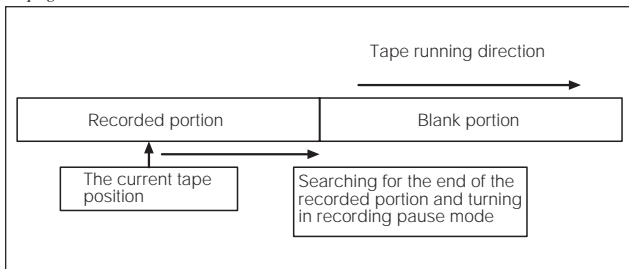

End Search function

Searching for the end of the recording, then switching to recording pause mode

To start the recording again after rewinding the recorded tape, playing it back and stopping the camcorder, follow the procedure below.

Press the RET button on the Lens.

3

The tape automatically runs and stops at the end of the recorded portion of the tape. The camcorder automatically switches to recording pause mode and is ready to start recording again.

Note

When the STOP KEY FREEZE function is set to become active on the VTR MODE 4 page of the MAINTENANCE menu, the picture is frozen once you push the STOP button during playback. To activate the end search function, push the STOP button again to stop the camcorder and press the RET button.

3-3 Checking the Recording — Playback

By pressing the PLAY button, you can review any length of recording in the viewfinder in black and white. There are two other ways to review the recording.

- **Recording review:** You can view the last 2 seconds of the recording in the viewfinder in black and white.
- **Color playback:** You can see the recording in color on a color video monitor without the need for any external adaptor.

You may also view the picture during searching by rewinding or fast forwarding by pressing the PLAY + REW button or PLAY + FWD button.

See “2-3 Audio Functions” on page 2-5 for information about the switches and controls used to select the audio output signal and to adjust the audio level.

3-3-1 Checking the Last Two Seconds of the Recording — Recording Review

If you press the RET button on the lens while recording is paused, the last two seconds of the tape is automatically rewound, and that segment is played back on the viewfinder screen. Use this function to check whether recording went smoothly. If you hold the RET button down longer, at most 10 seconds of the tape is rewound and played back. After playback, the camcorder is ready to start recording again.

By assigning the LENS RET function to the ASSIGN 1 switch, you can use the ASSIGN 1 switch in the same way as the RET button on the lens.

For details, see “4-8-5 Assigning Functions to ASSIGN 1/2 Switches” on page 4-109.

Note

The recording review functions only works if the recording you have made is at least 3 seconds long.

3-3-2 Checking the Recording on the Color Video Monitor — Playback in Color

Connect an HD color video monitor with the HD SDI input connector to the HD SDI OUT connector of the camcorder. By pressing the PLAY button, you can view the recorded picture.

3

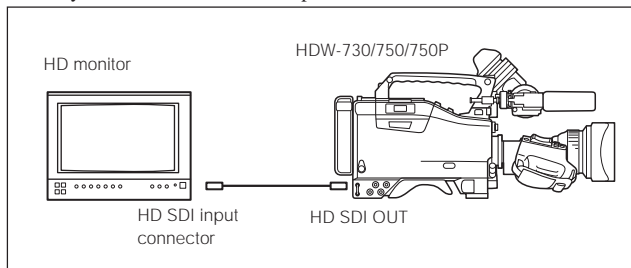

Color playback

Note

If HD SDI OUT is set to OFF on the OUTPUT SEL page of the USER menu, you cannot view the picture. Set HD SDI OUT to ON.

For detailed information, see “4-8-2 Selecting the Output Signals” on page 4-101.

When using an HKDW-702 extension board (not supplied) for down converting

Connect the color video monitor to the TEST OUT connector or VBS/SDI OUT connector of the camcorder (when an HKDW-702 is installed). By pressing the PLAY button, you can view the recorded picture.

The signal output from each connector depends on the menu settings.

For detailed information, see “4-8-2 Selecting the Output Signals” on page 4-101.

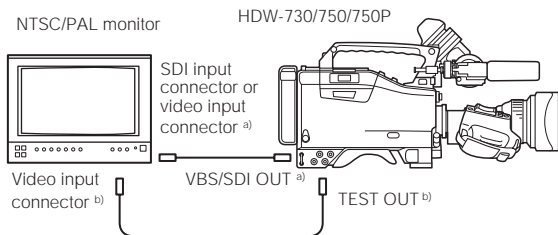

- a) As the output signal from the VBS/SDI OUT connector, when SDI is selected on the OUTPUT SEL page of the USER menu, connect to the SDI input connector. When VBS is selected, connect to the video input connector.

Note

When REAR BNC OUT SEL is set to OFF on the OUTPUT SEL page of the USER menu, the signal is not output from the VBS/SDI OUT connector.

For detailed information, see “4-8-2 Selecting the Output Signals” on page 4-101.

- b) When SD is selected as the output signal from the TEST OUT connector, connect to the video input connector.

Color playback

3-4 Recording the Recording Start Time Code onto the Memory Label — Tele-File

3

The VTR section is compatible with the Tele-File memory label system. This system allows you to record the recording start time code, model name, serial No. and TAPE format onto the MLB-1M-100 memory label (not supplied). This is very helpful for management of the cassette tapes and to improve the efficiency of the tape editing.

The memory label attached to the cassette is automatically detected.

To record the recording start time code onto the memory label

Follow the procedure below to record the recording start time code.

- 1 Insert the cassette onto which the MLB-1M-100 memory label has been attached.

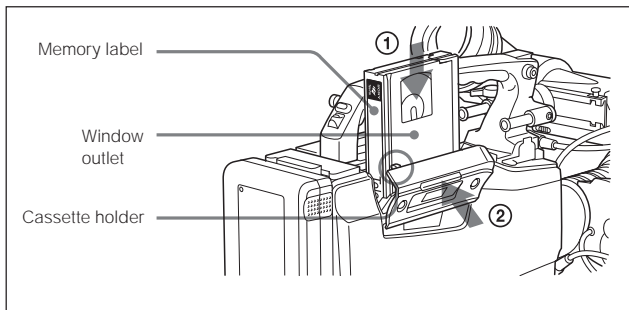

- 2 Press the VTR START button or the VTR button on the lens.

At the instant the recording starts, the time code of the recording start is recorded on the memory label.

To confirm the remaining capacity on the memory label

- 1 Set the MENU ON/OFF switch to ON while pushing the MENU knob .

The TOP menu appears.

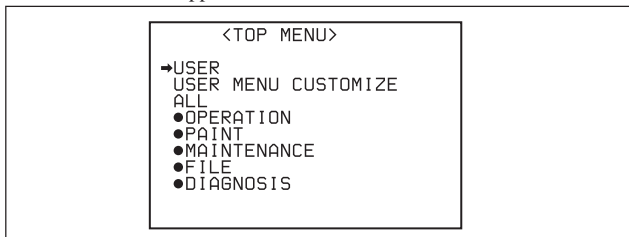

- 2 Turn the MENU knob to move the → mark to FILE.
- 3 Push the MENU knob.

When the FILE menu is first used, the CONTENTS page appears. Or if you used the FILE menu already, the page that was on the screen when the last FILE menu operation ended appears on the viewfinder screen.

- 4 When the CONTENTS page is displayed, turn the MENU knob to move the → mark to TELE FILE, then push the MENU knob. When any page of the FILE menu is displayed, turn the MENU knob until the TELE FILE page appears, then push the MENU knob.

(Continued)

The TELE FILE page appears.

```
?10 TELE FILE      TOP
TELE FILE CLEAR : EXEC
ID:
SIZE   :      1KBYTE
REMAIN :      100%
STATUS :  STANDBY
```

The remaining capacity of the memory label is displayed at the REMAIN column.

You can record the recording start time code about 130 times on the memory label of 1 Kilobyte.

Note

When the remaining capacity of the memory label becomes 0 %, you can not record the recording start time code any more.

“0 %” is displayed at the REMAIN column and the message “MEMORY FULL” is displayed at the STATUS column.

Warnings on the viewfinder screen when the remaining capacity is 0 %

In the following cases, the message “TELE FILE MEMORY FULL” is displayed at the setting change and adjustment progress message display area of the viewfinder.

- When loading the cassette onto which the memory label whose memory capacity is 0 % is attached.
- When loading the cassette onto which the memory label whose memory capacity is 0 % is attached and starting /stopping the recording.

To clear recorded data

- 1 Follow steps 1 to 4 in “To confirm the remaining capacity on the memory label” until the TELE FILE page of the FILE menu is displayed on the viewfinder screen.

The TELE FILE page appears.

```
?10 TELE FILE      TOP
TELE FILE CLEAR : EXEC
ID:
SIZE   :      1KBYTE
REMAIN :      100%
STATUS : STANDBY
```

- 2 Turn the MENU knob to move → mark to TELE FILE CLEAR, then push the MENU knob.

```
S10 TELE FILE      TOP
  CLEAR DATA OK? YES→NO
→TELE FILE CLEAR :▷EXEC
ID:
SIZE   :      1KBYTE
REMAIN :      100%
STATUS : STANDBY
```

The message “CLEAR DATA OK? YES NO” appears. In this case, the → mark is displayed on the front of “NO” and “NO” blinks.

(Continued)

-
- 3** Turn the MENU knob to move → mark to YES (“YES” blinks), then push the MENU knob.

The data recorded on the memory label is cleared.
100 % appears at the REMAIN column.

3

Notes

- When the memory label is protected from accidental erasure, you cannot clear recorded data.
- The time code data is cleared. However, the memory label ID is not cleared.

3-5 Freezing a Picture during Playback

Pressing the STOP button during playback stops playback and freezes the picture.

The VTR MODE 4 page of the MAINTENANCE menu allows you to set the freeze-frame mode where you can view the frozen picture during playback.

3

Performing the settings required for freezing the picture

- 1 Follow steps 1 to 4 in “Recording markers to the tape” on page 3-15 to display the VTR MODE 4 page of the MAINTENANCE menu.

```
? 090VTR MODE-4
REC TALLY BLANK :   ON
REC START STOP  :   OFF
MODE SELECT     :   SEL
TIMER SET       :   1H
STBY OFF TIMER  :  60MIN
STOP KEY FREEZE :   OFF
```

(Continued)

- 2** Turn the MENU knob to move the → mark to STOP KEY FREEZE, then push the MENU knob.

3

```
? 090UTR MODE-4
REC TALLY BLANK : ON
REC START STOP : OFF
MODE SELECT : SEL
TIMER SET : 1H
STBY OFF TIMER : 60MIN
→STOP KEY FREEZE : ● OFF
```

The → mark at the left of STOP KEY FREEZE changes to a ● mark and the ● mark at the left of the setting changes to a ? mark.

- 3** Turn the MENU knob clockwise or counterclockwise until the desired freeze mode appears.

If you turn the MENU knob clockwise or counterclockwise, the freeze mode changes in the following sequence: OFF ↔ FRAME ↔ FIELD.

Setting	Contents
OFF	Deactivates the freeze function.
FRAME	Freezes pictures in frame mode. This mode is effective for freezing pictures of objects that are not moving.
FIELD	Freezes pictures in field mode. This mode is effective for freezing moving pictures.

- 4** Push the MENU knob.

The ? mark at the left of the setting changes to a ● mark and the ● mark at the left of STOP KEY FREEZE changes to a → mark.

- 5 To end menu operation, set the MENU ON/OFF switch to OFF or close the cover of the menu operating section.

Viewing frozen pictures

- 1 Push the PLAY button to start playback.
- 2 Push the STOP button at the instant when you want to freeze the picture.

The tape stops running and the picture is frozen.

The time code is displayed in the counter display and the PLAY indicator blinks (one flash/second).

Changing to another mode

To cancel the freeze-frame mode for viewing the frozen picture and change to another mode, proceed as follows.

To restart playback: Push the PLAY button.

To view the pictures shot by the camcorder: Push the STOP button.

To rewind the tape: Push the REW button.

To fast forward the tape: Push the FF button.

To eject the tape: Push the EJECT button.

Notes

- In the freeze-frame mode, you cannot start recording pictures on the tape. To start recording the shot pictures again, push the STOP button to finish playback and then push the VTR START button.
- When changing to the end search mode from the freeze-frame mode, push the STOP button first, and then push the RET button.

When remotely controlling the camcorder from an RM-B150 remote control unit (not supplied)

You can perform the same operation from an RM-B150.

3-6 Setting the Stand-by off Timer During Rec-Pause

The VTR SAVE/STBY switch allows you to control the VTR power mode during pauses in recording (rec-pause) or when stopped.

However, even in the standby mode (with the VTR SAVE/STBY switch set to STBY), you can set the VTR in such a way that the mode is automatically switched from the standby mode to save mode when the tape does not run for a preset time, using the VTR MODE 4 page of the MAINTENANCE menu.

3

- 1 Follow steps 1 to 4 in “Recording markers on the tape” on page 3-15 to display the VTR MODE 4 page of the MAINTENANCE menu.
- 2 Turn the MENU knob to move the → mark to STBY OFF TIMER, then push the MENU knob.

```
? 09OVTR MODE-4
REC TALLY BLINK :    ON
REC START STOP  :    OFF
MODE SELECT     :    SEL
TIMER SET       :    1H
→STBY OFF TIMER : ●60MIN
STOP KEY FREEZE :    OFF
```

The → mark at the left of STBY OFF TIMER changes to a ● mark and the ● mark at the left of the setting changes to a ? mark.

-
- 3** Turn the MENU knob clockwise or counterclockwise until the desired STBY OFF TIMER appears.

If you turn the MENU knob clockwise or counterclockwise, STBY OFF TIMER changes in the following sequence: 60MIN ↔ 30MIN ↔ 10MIN ↔ 5MIN ↔ OFF.

In order not to enter in the VTR SAVE mode, select OFF.
To enter the VTR SAVE mode, select the desired time.

- 4** Press the MENU knob.

The ● mark at the left of the STBY OFF TIMER changes to an → mark and the ? mark to the left of the setting changes to the ● mark.

- 5** To end menu operations, set the MENU ON/OFF switch to OFF, or close the cover.

4-1 Adjusting the Black Balance and the White Balance

To always obtain excellent image quality when using this camcorder, conditions may require that both the black balance and the white balance be adjusted.

Black balance adjustment

The black balance will require adjustment in the following cases.

- When the camcorder is first used
- When the camcorder is used under conditions in which the surrounding temperature has changed greatly
- When the camcorder has not been used for a long time
- When the GAIN selector values have been changed by using the USER menu

It is not usually necessary to adjust the black balance when using the camcorder after it has been off.

White balance adjustment

Always readjust the white balance when the lighting conditions change.

Viewfinder screen displays

If the black balance or white balance adjustment is started, messages that report on the progress and results are displayed on the viewfinder screen when VF DISP MODE is set to 2 or 3 on the VF DISP 1 page of the USER menu.

Note

Black balance and white balance adjustment values that are automatically set by the camcorder and the various settings are stored in the camcorder memory and retained even when the power is turned off.

4-1-1 Adjusting the Black Balance

In automatic black balance mode, adjustments are performed in the following sequence: clamp level, black set, and black balance. Manual black balance adjustment can be selected from the setup menu.

Follow the procedure below to adjust the black balance.

- 1 Set the OUTPUT/DCC switch to CAM.
- 2 Push the AUTO W/B BAL switch to BLK and release the switch.

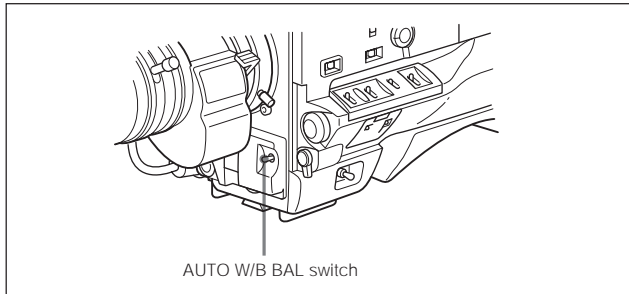

The switch returns to the center position, and the adjustment is executed.

During adjustment, the following message is displayed on the viewfinder screen.

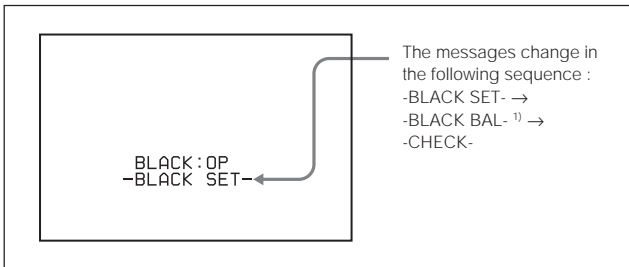

The black balance adjustment ends in a few seconds with the message “BLACK:OK” and the adjustment setting is automatically stored in memory.

Notes

- During the black balance adjustment, the iris is automatically closed.
- During the black balance adjustment, the gain selection circuit is automatically activated so you may see flickering on the viewfinder screen, but this is not a fault.

1) If the existing black balance adjustment is satisfactory, the message “BLACK BAL” may not appear, that is, the automatic black balance adjustment may be omitted to save time.

If automatic black balance adjustment cannot be made

If the black balance adjustment cannot be completed normally, an error message will appear for about 3 seconds on the viewfinder screen (in display mode 2 or 3).

Possible messages are listed below.

Black balance adjustment error messages

Error message	Meaning
BLACK : NG IRIS NOT CLOSED	The lens iris did not close; adjustment was impossible.
BLACK : NG TIME LIMIT	Adjustment could not be completed within the standard number of attempts.
BLACK : NG R (or G or B) : OVERFLOW	The difference between the reference value and the current value is so great that it exceeds the range. Adjustment was impossible.

If any of the above error messages is displayed, retry the black balance adjustment. Keep pushing the AUTO W/B BAL switch to BLK until -BLACK SET- appears after the -CHECK- appears. If the error message occurs again, an internal check is necessary.

For information about this internal check, refer to "Maintenance Manual".

Note

If the lens cable is not firmly connected to the lens connector, it may not be possible to adjust the lens iris. If this happens, the black balance will be incorrect.

Black balance memory

Values stored in memory are held until the black balance is next adjusted.

If a memory error occurs

If the error message “: STORED DATA : NG” flashes on the viewfinder screen when the camcorder is turned on, the black balance and white balance memory contents have been lost.

Adjust the black balance and white balance again. Contact your Sony representative if this message continues to appear even after the black balance and white balance have been adjusted again.

For more information, refer to “Maintenance Manual.”

4-1-2 Adjusting the White Balance

Follow the procedure below to automatically adjust the white balance.

- 1 Adjust the switches as shown in the figure below.

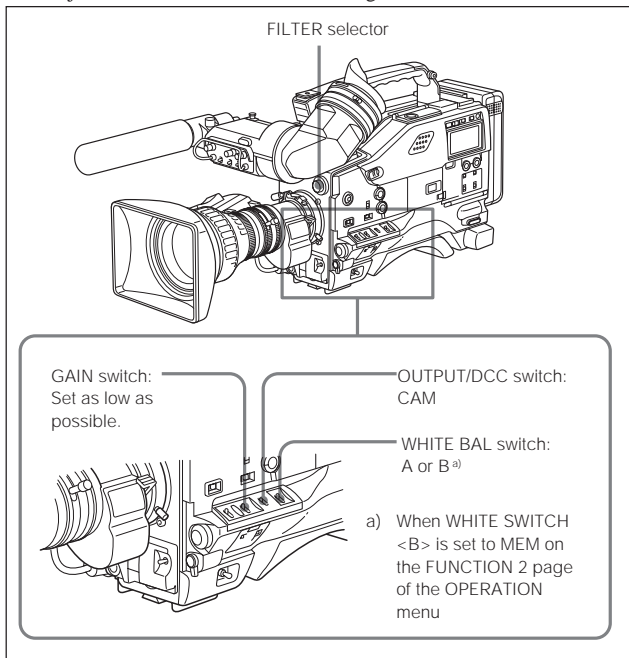

If the setting on the GAIN selector or WHITE BAL switch is changed, a message reporting the set position appears for about 3 seconds in the setting change and adjustment progress message display area of the viewfinder screen.

2 Adjust the FILTER selector to suit the lighting conditions.

ND filter		CC filter	
1	Clear	A	Cross filter
2	1/4 ND	B	3200K
3	1/16 ND	C	4300K
4	1/64 ND	D	6300K

If the setting of the FILTER selector is changed, a message reporting the set position appears for about 3 seconds in the setting change and adjustment progress message display area of the viewfinder screen (in display mode 3).

3 Place a white test card under the same lighting conditions as the subject to be shot and zoom up to it. Alternately, any white object such as a cloth or a wall could be used.

The absolute minimum white area is as follows:

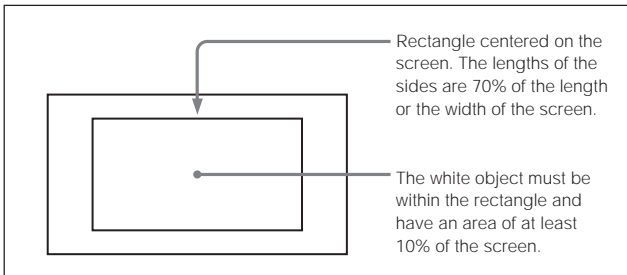

Note

Make sure there are not bright spots in the rectangle.

(Continued)

4 Adjust the lens iris.

If the lens is manually adjusted, adjust it as appropriate.

If the lens has an automatic iris, set the automatic/manual switch on the lens to automatic.

5 Push the AUTO W/B BAL switch to WHT and release the switch.

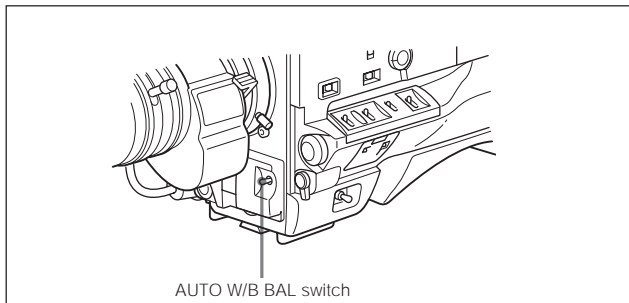

The switch returns to the center position, and the adjustment is executed.

During adjustment, the message “WHITE : OP” is displayed on the viewfinder screen (in display mode 2 or 3).

The white balance adjustment ends in a second with the message “WHITE : OK”, and the adjustment setting is automatically stored in the memory (A or B) that was selected in step 1.

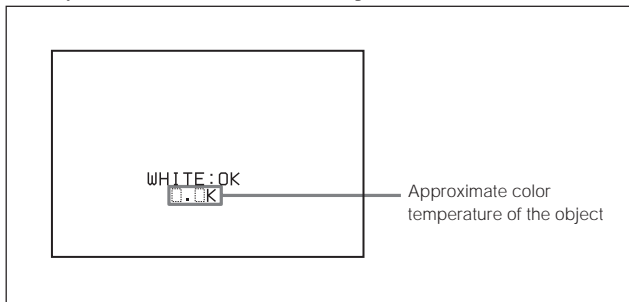
**Note**

If the camera has a zoom lens with an automatic iris, the iris may hunt¹⁾ during the adjustment. To prevent this, adjust the iris gain knob (marked with IG, IS, or S) on the lens.

For more information, refer to the lens operation manual.

.....

1) Hunting

Repeated brightening and darkening of an image, resulting from repeated response to automatic iris control.

If the automatic white balance adjustment cannot be made

If the white balance adjustment cannot be completed normally, an error message will appear for about 3 seconds on the viewfinder screen (in display mode 2 or 3).

Possible messages are listed below.

White balance adjustment error messages

Error message	Meaning
WHITE : NG LOW LEVEL	The white video level is too low. Either make open the lens iris or increase the gain.
WHITE : NG COLOR TEMP HIGH	The color temperature is too high. Select a suitable filter setting.
WHITE : NG COLOR TEMP LOW	The color temperature is too low. Select a suitable filter setting.
WHITE : NG TIME LIMIT	Adjustment could not be completed within the standard number of attempts.
WHITE : NG POOR WHITE AREA	The white area could not be checked.
WHITE : NG LEVEL TOO HIGH	The white video level is too high. Either narrow the lens iris opening or change the ND filter.

If any of the above error messages is displayed, retry the white balance adjustment. If the error message occurs again, an internal check is necessary.

For information about this internal check, refer to "Maintenance Manual".

If you have no time to adjust the white balance

Set the WHITE BAL switch to PRST. The white balance is automatically set to 3200 K when the FILTER selector is in position B, to C for 4300 K and to D for 6300 K.

For details about setting the white balance manually, see “4-1-2 Adjusting the White Balance” on page 4-6.

White balance memory

Values stored in memory are held until the white balance is next adjusted.

There are two sets of white balance memories, A and B, and adjustments for each of the filters can be automatically stored in the memory corresponding to the setting (A or B) of the WHITE BAL switch. The camcorder has four built-in filters, so a total of eight (4×2) adjustments can be stored. The number of memories allocated each A and B can be limited to one each by setting WHT FILTER INH. to ON on the FUNCTION 3 page of the MAINTENANCE menu. In this case, the memory contents are not linked to the filters.

When the WHITE BAL switch is set to B whereas, on the FUNCTION 2 page of the OPERATION menu, “WHITE SWITCH ” is set to ATW, the ATW function is activated to automatically adjust the white balance of the picture being shot for varying lighting conditions.

If a memory error occurs

If the error message “: STORED DATA : NG” flashes on the viewfinder screen when the camcorder is turned on, the white balance and black balance memory contents have been lost.

Adjust the white balance and black balance again. Contact your Sony representative if this message continues to appear even after the white balance and black balance have been adjusted again.

For more information, refer to “Maintenance Manual.”

4-2 Setting the Electronic Shutter

This section describes the shutter modes that can be used with the electronic shutter of the camcorder, and describes the procedure for selecting the shutter speed and mode.

4-2-1 Shutter Modes

The shutter modes that can be used with the electronic shutter and the shutter speeds that can be selected are listed below.

Selectable shutter modes and speeds

Mode	Shutter speed	Application
Standard	HDW-730 (59.94I format)/ HDW-750: 1/100, 1/125, 1/250, 1/500, 1/1000, 1/2000 (sec.)	For shooting fast-moving subjects with little blurring.
	HDW-730 (50I format)/ HDW-750P (50I format): 1/60, 1/125, 1/250, 1/500, 1/1000, 1/2000 (sec.)	
	HDW-750P (25PsF format): 1/33, 1/50, 1/60, 1/100, 1/125, 1/250, 1/500, 1/1000, 1/2000 (sec.)	
ECS (Extended Clear Scan)	HDW-730 (59.94I format): 60.0 to 4300 Hz	For obtaining images with no horizontal bands of noise when shooting subjects such as monitor screens.
	HDW-730 (50I format): 50.0 to 4700 Hz	
	HDW-750: 30.0 to 4300 Hz	
	HDW-750P (50I format): 25.0 to 4700 Hz	
	HDW-750P (25PsF format): 25.0 to 2100 Hz	

Mode	Shutter speed	Application
EVS ^{a)}	HDW-730 (59.94I format)/	Improved vertical resolution. However, the sensitivity and dynamic range are reduced.
(Enhanced Vertical definition System)	HDW-750: 1/60 sec. (fixed)	
	HDW-730 (50I format)/	
	HDW-750P (50I format):	
	1/50 sec. (fixed)	

a) For an HDW-750P, operating with the 25PsF format, this function is not available.

Notes

- Whatever the operating mode of the electronic shutter, the sensitivity of the CCD decreases with increasing shutter speed.
- When the automatic iris is used, the iris opens wider and wider as the shutter speed increases, thus reducing the depth of field.
- Under artificial light, particularly fluorescent or mercury lamps, the light intensity may appear to be constant, but the strengths of each of the R, G and B colors are actually changing in synchronization with the frequency of the power supply (“flicker”). Using an electronic shutter under such lighting could make the flicker even worse. Color flicker is particularly likely to happen when the power supply frequency is 60 Hz (with the 59.94I format) or 50 Hz (with the 50I format). However, if the power frequency is 50 Hz (with the 59.94I format) or 60Hz (50I format), setting the shutter speed to 1/100 or 1/60 can reduce this flicker.
- When a bright object is shot in EVS mode or ECS mode in such a manner that it fills the screen, the upper edge of the picture may have poor quality because of an inherent characteristic of CCD. Before using EVS mode or ECS mode, check the shooting conditions. You can turn on or off the EVS mode on the SW STATUS page of the PAINT menu.

4-2-2 Selecting the Shutter Mode and Speed

Use the SHUTTER selector to select a shutter mode or a standard-mode shutter speed. To set the shutter speed in ECS mode, with the SHUTTER switch set to ON and the ECS mode selected, use the MENU knob for adjustment.

You can use the SHT ENABLE page of the OPERATION menu to narrow the range of choice in advance, or to select in advance whether or not you use ECS.

4

Setting the shutter mode and standard-mode shutter speed

Once the shutter speed is selected, it is retained even when the camcorder power is turned off.

- 1 Follow the procedure described in “4-7-2 Selecting the Display Items” (page 4-70) to set to VF DISPLAY MODE to 2 or 3 from the VF DISP 1 page of the USER menu.

2 Push the SHUTTER selector from ON to SEL.

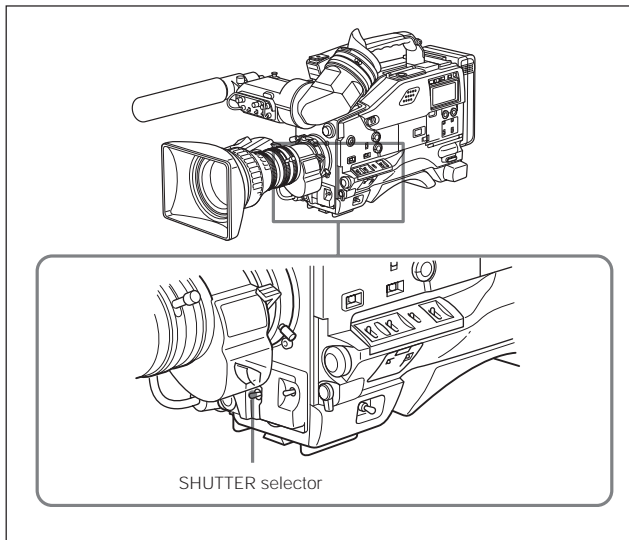

The current shutter setting appears for about 3 seconds in the setting change and adjustment progress message display area of the viewfinder screen.

E.g. “: SS : 1/250” or “: ECS : 60.00 Hz”

(Continued)

- 3** Before the message from step 2 disappears, push the SHUTTER selector to SEL again and repeat until the desired mode or speed appears.

Pushing the SHUTTER selector to SEL repeatedly allows you to cycle through the settings of mode and speed preselected on the SHT ENABLE page of the OPERATION menu.

Note that all modes and all standard-mode speeds listed in the table on page 4-12 are preselected using the SHT ENABLE page of the OPERATION menu.

4

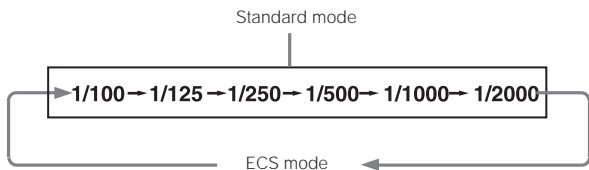

1/100 for the HDW-730 (59.94I format)/HDW-750
1/60 for the HDW-730 (50I format)/HDW-750P (50I format)
For the HDW-750P (25PsF format), the available shutter speeds are 1/33, 1/50, 1/60, 1/100, 1/125, 1/250, 1/500, 1/1000, 1/2000 (sec.)

Setting the shutter speed in ECS mode

Follow the procedure below.

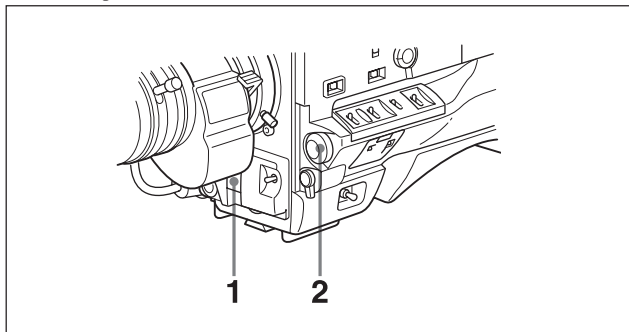

- 1 Set the shutter speed mode to ECS.

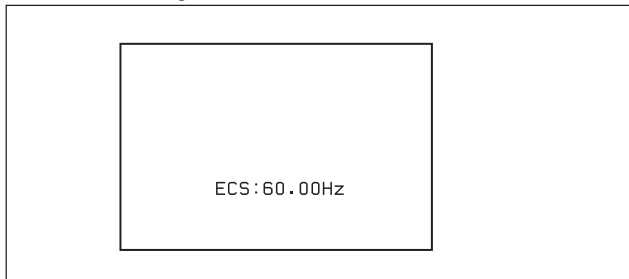

ECS (Extended clear scan) page (factory settings)

- 2 Turn the MENU knob counterclockwise as seen from the front of the camera to increase the value, or clockwise to decrease the value, until the desired frequency appears.

(Continued)

The frequency range can be changed as shown below.

HDW-730 (59.94I format): 60.0 to 4300 Hz

HDW-730 (50I format): 50.0 to 4700 Hz

HDW-750: 30.0 to 4300 Hz

HDW-750P (50I format): 25.0 to 4700 Hz

HDW-750P (25PsF format): 25.0 to 2100 Hz

When an RM-B150 Remote Control Unit is connected

You can set the shutter speed of ECS with the rotary encoder of the RM-B150.

Changing the range of choice of shutter mode and speed settings

You can reduce the time required to select the shutter mode and speed by narrowing the choice of settings in advance. This can be done by using the SHT ENABLE page of the OPERATION menu.

Follow the procedure below.

Note

The settings selected on the SHT ENABLE page of the OPERATION menu become invalid when the RM-B150 Remote Control Unit is connected to the camcorder.

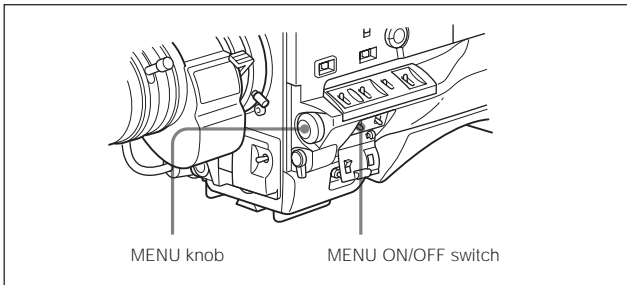

Changing the range of choice of shutter mode and speed settings

-
- 1 Set the MENU ON/OFF switch to ON while pushing the MENU knob.

The TOP menu appears.

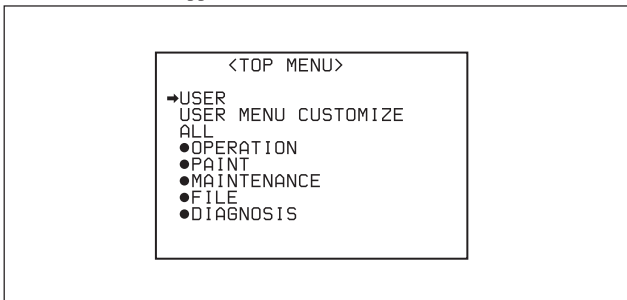

- 2 Turn the MENU knob to move the → mark to OPERATION.
- 3 Push the MENU knob.

When the OPERATION menu is first used, the CONTENTS page appears.

Or if you used the OPERATION menu already, the page that was on the screen when the last OPERATION menu operation ended appears on the viewfinder screen.

- 4 When the CONTENTS page is displayed, turn the MENU knob to move the → mark to SHT ENABLE, then push the MENU knob. When any page of the OPERATION menu is displayed, turn the MENU knob until the SHT ENABLE page appears, then push the MENU knob.

(Continued)

The SHT ENABLE page appears, and the current settings are displayed on the page.

17OSHT ENABLE			
→SHUTTER	ECS	:●	ON
SHUTTER	1/100	:	ON
SHUTTER	1/125	:	ON
SHUTTER	1/250	:	ON
SHUTTER	1/500	:	ON
SHUTTER	1/1000	:	ON
SHUTTER	1/2000	:	ON

The menu is for a camcorder which operates with the 59.94i format.

- 4**
- 5** Turn the MENU knob to move the → mark to the mode or shutter speed you want.

The → mark at the left of the selected item changes to a ● mark and the ● mark at the left of the setting changes to a ? mark.

- 6** Turn the MENU knob until ON appears, then push the MENU knob.

The ● mark at the left of the selected item changes to a → mark and the ? mark at the left of the setting changes to a ● mark. To set another mode or speed continuously, return to step 5.

For only the shutter speed set to ON, you can select the shutter speed using the SHUTTER switch.

- 7** To end the menu operation, set the MENU ON/OFF switch to OFF. Or close the cover of the Menu Operating section.

The menu disappears from the viewfinder screen and the display indicating the current status of the camcorder appears along the top and bottom of the viewfinder.

4-3 Changing the Reference Value for Automatic Iris Adjustment

The reference value for automatic iris adjustment can be changed to enable the shooting of clear pictures of back-lit subjects, or to prevent white crush from the subject on which a spot light is turned. The reference value for the lens iris can be set within the following range with respect to the standard value.

- 0.25: about 0.25 stop further open
- 0.5: about 0.5 stop further open
- 0.75: about 0.75 stop further open
- 1: about 1 stop further open
- -0.25: about 0.25 stop further closed
- -0.5: about 0.5 stop further closed
- -0.75: about 0.75 stop further closed
- -1: about 1 stop further closed

Also you can set the area where light detection occurs.

Changing the reference value

- 1** Set the MENU ON/OFF switch to ON.

When the USER menu is first used, the CONTENTS page appears. Or if you used the USER menu already, the page that was on the screen when the last USER menu operation ended appears on the viewfinder screen.

- 2** When the CONTENTS page is displayed, turn the MENU knob to move → mark to AUTO IRIS, then push the MENU knob. When any page of the USER menu is displayed, turn the MENU knob until the AUTO IRIS page appears, then push the MENU knob.

(Continued)

The AUTO IRIS page appears.

090AUTO IRIS			
→ IRIS OVERRIDE	:	●	ON
IRIS SPEED	:		ON
CLIP HIGH LIGHT	:		OFF
IRIS WINDOW	:		1
IRIS WINDOW	:		OFF
IRIS VAR WIDTH	:		240
IRIS VAR HEIGHT	:		135
IRIS VAR H POS	:		0
IRIS VAR V POS	:		0

- 4** Turn the MENU knob to move the → mark to IRIS OVERRIDE.

The → mark at the left of the selected item changes to a ● mark and the ● mark at the left of the setting changes to a ? mark.

- 4** Turn the MENU knob until ON appears, then push the MENU knob.

The ● mark at the left of the selected item changes to a → mark and the ? mark at the left of the setting changes to a ● mark. The IRIS OVERRIDE is set to ON.

- 5** Set the MENU ON/OFF switch to OFF. Or close the cover of the Menu Operating section.

The AUTO IRIS page disappears from the viewfinder.

- 6** Turn the MENU knob to change the reference value.

Note

Be sure to confirm that the shutter speed is set to any mode other than ECS.

The changed reference value is retained until the power of the camcorder is turned off.

Even if the reference value is changed, it reverts to the standard value every time the power is turned on. The reference value is normally set to the standard value.

To open the iris by 0.25 stop:

Turn the MENU knob further counterclockwise as seen from the front of the camera.

One bar (□) appears in the upper part to the left of the F number in the iris indication.

To open the iris by 0.5 stop:

Turn the MENU knob further counterclockwise as seen from the front of the camera.

One bar (■) appears in the upper part to the left of the F number in the iris indication.

To open the iris by 0.75 stop:

Turn the MENU knob further counterclockwise as seen from the front of the camera.

Two bars (□■) appear in the upper part to the left of the F number in the iris indication.

To open the iris by 1 stop:

Turn the MENU knob counterclockwise as seen from the front of the camera.

Two bars (■■) appear in the upper part to the left of the F number in the iris indication.

To close the iris by 0.25 stop:

Turn the MENU knob clockwise as seen from the front of the camera.

One bar (□) appears in the lower part to the left of the F number in the iris indication.

To close the iris by 0.5 stop:

Turn the MENU knob clockwise as seen from the front of the camera.

One bar (■) appears in the lower part to the left of the F number in the iris indication.

(Continued)

To close the iris by 0.75 stop:

Turn the MENU knob clockwise as seen from the front of the camera.

Two bars (□■) appear in the lower part to the left of the F number in the iris indication.

To close the iris by 1 stop:

Turn the MENU knob further clockwise as seen from the front of the camera.

Two bars (■■) appear in the lower part to the left of the F number in the iris indication.

**Opening the lens iris**

Iris opened by 0.25 stop

■ F5.6

Iris opened by 0.5 stop

■ F5.6

Iris opened by 0.75 stop

■ ■ F5.6

Iris opened by 1 stop

■ ■ F5.6

Closing the lens iris

Iris closed by 0.25 stop

■ F5.6

Iris closed by 0.5 stop

■ F5.6

Iris closed by 0.75 stop

■ ■ F5.6

Iris closed by 1 stop

■ ■ F5.6

Opening or closing the lens iris

When the RM-B150 Remote Control Unit is connected

The IRIS control knob of the RM-B150 can be used for lens iris setting. The bar display (□) will not appear, however.

Selecting the automatic iris window

1 Follow the procedure of steps 1 and 2 described in “Changing the reference value” on page 4-21 to display the AUTO IRIS page.

2 Turn the MENU knob to move the → mark to IRIS WINDOW IND.

The → mark at the left of the selected item changes to a ● mark and the ● mark at the left of the setting changes to a ? mark.

3 Turn the MENU knob until ON appears, then push the MENU knob.

The ● mark at the left of the selected item changes to a → mark and the ? mark at the left of the setting changes to a ● mark.

The setting is executed.

The currently selected auto iris window appears on the viewfinder screen.

If it is not necessary to display the auto iris window on the viewfinder, set to OFF.

4 Turn the MENU knob to move the → mark to IRIS WINDOW.

The → mark at the left of the selected item changes to a ● mark and the ● mark at the left of the setting changes to a ? mark.

(Continued)

- 5** Turn the MENU knob until the desired auto iris window appears, then push the MENU knob.



The shaded parts in the illustrations indicate the area where light detection occurs.

Auto iris window

The ● mark at the left of the selected item changes to a → mark and the ? mark at the left of the setting changes to a ● mark.

If you select VARIABLE, the following items become effective and you can set the window of the desired size.

Set each item to the desired size.

Item	Setting
IRIS VAR WIDTH	The width of the window
IRIS VAR HEIGHT	The height of the window
IRIS VAR H POS	The position of the window in the horizontal direction
IRIS VAR V POS	The position of the window in the vertical direction

-
- 6** Set the MENU ON/OFF switch to OFF. Or close the cover of the Menu Operating section.

The menu disappears from the viewfinder screen and the display indicating the current status of the camcorder appears along the top and bottom of the viewfinder.

To reduce the influence to the auto iris due to shooting a high luminance subject

When shooting a high luminance subject, the auto iris closes too much and a white crush may occur on the image. In such a case, you can reduce the influence to the auto iris by setting CLIP HIGH LIGHT to ON on the AUTO IRIS page of the USER menu.

Since the level exceeding a certain level is clipped, the influence to the auto iris is reduced.

4-4 Adjusting the Audio Level

Setting the AUDIO SELECT CH-1/CH-2 switches to AUTO automatically adjusts the input levels of the audio signal to be recorded in audio channel CH-1 or CH-2. You can also adjust the audio level manually.

For the audio level of the signal to be recorded in audio channel CH-3 or CH-4

Only automatic adjustment of the audio level is available.

When the CH-1/2 / CH-3/4 switch is set to CH-3/4, the audio channel level meters display the level of the audio signals recorded in audio channels CH-3 and CH-4. You can select the audio input signals to be recorded for audio channel CH-3 and 4 by using the AUDIO IN CH-3/CH-4 switches.

Manually adjusting the audio levels of the audio input from the AUDIO IN CH-1/CH-2 connectors

Follow the procedure described below to adjust the audio levels of the audio input from the AUDIO IN CH-1/CH-2 connectors, which are to be recorded in audio channels CH-1 and CH-2.

Note

When **1** and **2** are not displayed under the audio channel level meters, the CH-1/2/ CH-3/4 switch is set to the CH-3/4 position. Set this switch to CH-1/2.

At the factory setting, the XLR connection automatic detection mode of the AUDIO IN CH-1/CH-2 connectors is set to ON. In this case, start the operation from step 2.

When the XLR connection automatic detection mode is set to OFF, start the operation from step 1.

You can set the XLR connection automatic detection mode on the VTR MODE 1 page of the MAINTENANCE menu.

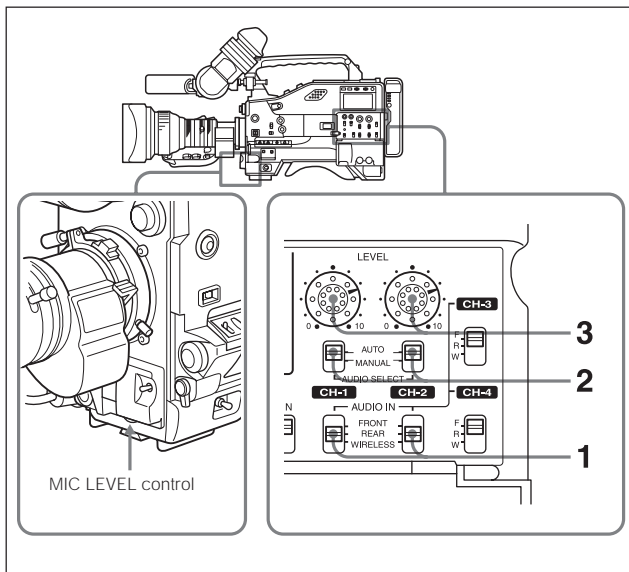

Manual adjustment of the audio levels of AUDIO IN CH-1/CH-2

- 1** Set the AUDIO IN CH-1/CH-2 switch which corresponds to the channels to be adjusted among input signals connected to AUDIO IN CH-1/CH-2 connectors to REAR.
To adjust and record both of channels 1 and 2, set the both AUDIO IN CH-1 and AUDIO IN CH-2 switches to REAR.
- 2** Set the AUDIO SELECT switch(es) corresponding to the channel selected in step 1 to MANUAL.

(Continued)

- 3** Adjust the LEVEL controls corresponding to the channel selected in step 1 so that at the maximum sound level, the level meter indicates -18 dB (segment above 20 segment). The second bar from the top may turn on occasionally, but do not allow the top bar to go on. If it goes on, the audio level is too high.

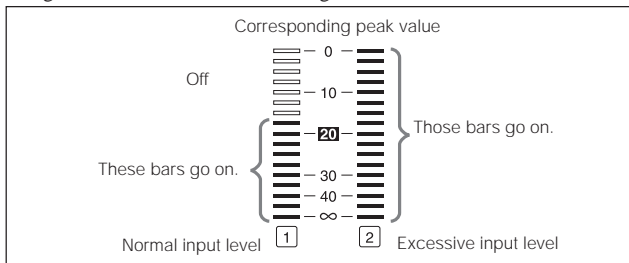

Using the LEVEL (CH-1/CH-2) controls

You can select the audio level controls to be used for adjusting the level of the audio signals input to the AUDIO IN CH-1/CH-2 connectors on the VTR MODE-2 page of the MAINTENANCE menu.

	At the factory setting	Example 1	Example 2
Audio level to the CH-1	LEVEL (CH-1) control	MIC LEVEL control	The MIC LEVEL control is linked with LEVEL (CH-1) control
Audio level to the CH-2	LEVEL (CH-2) control	MIC LEVEL control	The MIC LEVEL control is linked with LEVEL (CH-2) control

Note

When you select that the MIC LEVEL control is linked with the LEVEL (CH-1/CH-2) control(s), if the MIC LEVEL control is turned fully counterclockwise to 0, the audio signal input to AUDIO IN CH-1/CH-2 connectors cannot be recorded. Before adjusting the audio level using the LEVEL (CH-1/CH-2) controls, confirm the setting of the MIC LEVEL control.

Manually adjusting the audio level of the front microphone

You can adjust the audio level input from the front microphone connected to the MIC IN connector, which is to be recorded in audio channels CH-1 and CH-2.

Notes

- When **1** and **2** are not displayed under the audio channel level meters, the CH-1/2 / CH-3/4 switch is set to the CH-3/4 position. Set this switch to CH-1/2.
- If the XLR connection automatic detection mode is set to ON, when the cables are connected to the AUDIO IN CH-1/CH-2 connectors, the camcorder detects the connection to the AUDIO IN CH-1/CH-2 connectors. Thus, the AUDIO IN switch is internally reset to REAR and the audio signals input to the AUDIO IN CH-1/CH-2 connectors are automatically selected.

Before adjusting the audio level of the front microphone, confirm that no cables are connected to the AUDIO IN CH-1/CH-2 connectors. Or set the REAR XLR AUTO to OFF on the VTR MODE 1 page of the MAINTENANCE menu.

(Continued)

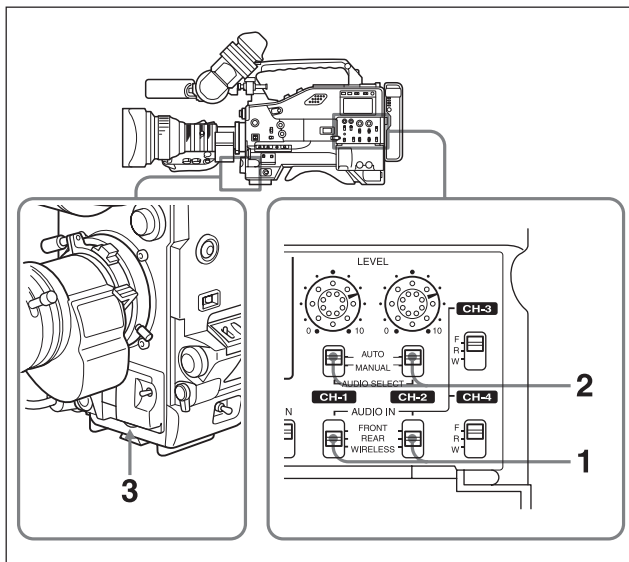

Microphone audio level manual adjustment (1)

- 1** To record the stereo sound, set both AUDIO IN CH-1 and CH-2 switches to FRONT.
To record the monaural sound, set the AUDIO IN CH-1 and/or CH-2 switch(es) corresponding to the channel to be adjusted and recorded to FRONT.
For detailed information, see “Recording the stereo sound” on page 5-18.
- 2** Set the AUDIO SELECT switch(es) for the desired channel(s) selected in step 1 to MANUAL.

- 3** Rotate the MIC LEVEL knob to adjust the audio level so that at the maximum sound level, the level meter indicates -18 dB (segment above 20 segments).
- The 10 bars from the bottom among 17 bars go on with the normal input volume.
 - The second bar from the top may turn on occasionally, but do not allow the top bar to go on. If it goes on, the audio level is too high.

Note

You cannot adjust the audio level of the L channel and R channel separately even if the stereo microphone is connected.

Using the LEVEL controls

You can select the audio level controls to be used to adjust the level of the audio signals input to the MIC IN connectors on the VTR MODE-2 page of the MAINTENANCE menu.

	At the factory setting	Example 1	Example 2
Audio level to the CH-1	MIC LEVEL control	LEVEL (CH-1) control	The LEVEL (CH-1) control is linked with MIC LEVEL control
Audio level to the CH-2	MIC LEVEL control	LEVEL (CH-2) control	The LEVEL (CH-2) control is linked with MIC LEVEL control

Note

When you select that LEVEL (CH-1/CH-2) control(s) is linked with the MIC LEVEL control, if the LEVEL (CH-1/CH-2) control(s) is turned fully counterclockwise to 0, the audio signal input to AUDIO IN CH-1/CH-2 connectors cannot be recorded. Before adjusting the audio level using the MIC LEVEL control, confirm the setting of the LEVEL (CH-1/CH-2) controls.

Input level of the audio channels CH-3 and CH-4

The levels of the audio signals recorded in audio channels CH-3 and CH-4 are automatically adjusted. You cannot adjust them manually.

You can select the audio signal to be recorded in audio channels CH-3 and CH-4 using the AUDIO IN CH-3/CH-4 switches.

The XLR connector automatic detection function does not affect audio signals recorded in audio channels CH-3 and CH-4.

4

Note

At the factory setting, since audio signals to be recorded in audio channels CH-3 and CH-4 are the same as those to be recorded in audio channels CH-1 and CH-2 (CH-1/CH-2 copy mode), the CH-3/CH-4 switches are not activated.

To activate these switches, change the setting of AUDIO CH3/4 MODE from CH1/2 to SW on the VTR MODE-1 page of the MAINTENANCE menu.

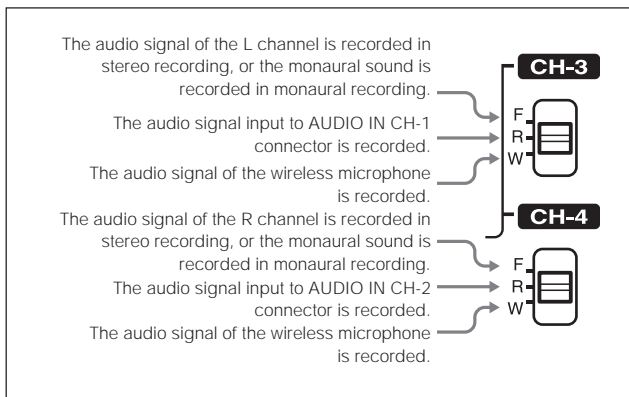

Audio signals to be recorded in audio channels CH-3 and CH-4

When an HDCA-901 camera adaptor is used

With an HDCA-901 (not supplied) connected to the camcorder, you can record separate sounds on audio channels 3 and 4. To record external audio signals from the HDCA-901 on audio channels 3 and 4, change the setting of CAMERA ADAPTER to ENABL on the VTR MODE 1 page of the MAINTENANCE menu. In such a case, the external audio signals are recorded on audio channels 3 and 4 regardless of the settings of AUDIO CH3/4 on the VTR MODE 1 page of the MAINTENANCE menu. Adjust the level of the input signal using the level adjustment knob of the HDCA-901.

4-5 Setting the Time Data

4-5-1 Setting the Time Code

The time code setting range is from 00 : 00 : 00 : 00 to 23 : 59 : 59 : 29 (hour : minute : second : frame).

Follow the procedure below to set the time code.

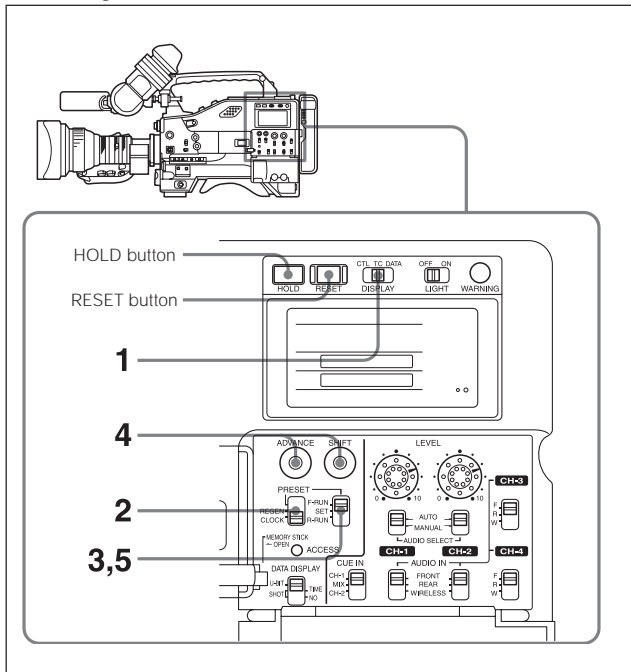

- 1 Set the DISPLAY switch to TC.

-
- 2 Set the PRESET/REGEN/CLOCK switch to PRESET.
 - 3 Set the F-RUN/SET/R-RUN switch to SET.
 - 4 Using the SHIFT and ADVANCE buttons, set the time code.
SHIFT: Selects a digit to set. Each time you press the button, the flashing digit moves one column to the right.
Pressing this button while holding down the HOLD button moves the flashing digit one to the left.
ADVANCE: Increments the value of the flashing digit.
Pressing this button while holding down the HOLD button decrements the flashing digit.

Resetting a modified numeric value to 00:00:00:00

To reset a numeric value that was modified, press the RESET button.

- 5 Set the F-RUN/SET/R-RUN switch to F-RUN or R-RUN.
F-RUN: Free run. The time code generator keeps running, regardless of the operating state of the VTR.
R-RUN: Recording run. The time code generator runs only while recording.

To set the drop frame mode/non-drop frame mode (only for the 59.94I format model, that is, an HDW-750 and an HDW-730 which operates with the 59.94I format)

You can select the drop frame (DF) mode or non-drop frame (NDF) mode on the FUNCTION 1 page of the USER menu or OPERATION menu or on the VTR MODE 3 page of the MAINTENANCE menu.

To make the time code continuous

When the F-RUN/SET/R-RUN switch is set to R-RUN, recording a number of scenes on the tape normally produces continuous time codes. If, however, you take the cassette out at some point, the time code will no longer be continuous.

To make the time code continuous, follow the procedure below.

- 1 Set the PRESET/REGEN/CLOCK switch to REGEN.
- 2 Use the PLAY buttons to play back.
- 3 Watching the playback, find the point of the previous recording on the tape from which you wish to continue recording, and press the STOP button.
- 4 Press the RET button on the lens.

This reads the previous recording and synchronizes the internal time code generator, thus allowing the new time code recorded to follow on consecutively.

4-5-2 Saving the Real Time in the Time Code

Setting the PRESET/REGEN/CLOCK switch to CLOCK saves the real time in the time code.

When it is necessary to set the real time, use the TIME DATE page of the DIAGNOSIS menu.

For details, see “4-8-6 Setting the Date/Time of the Internal Clock” on page 4-114.

4-5-3 Setting the User Bits

By setting the user bits (up to 8 hexadecimal digits), you can record user information such as the date, time, or scene number on the time code track.

Follow the procedure below to set the user bits.

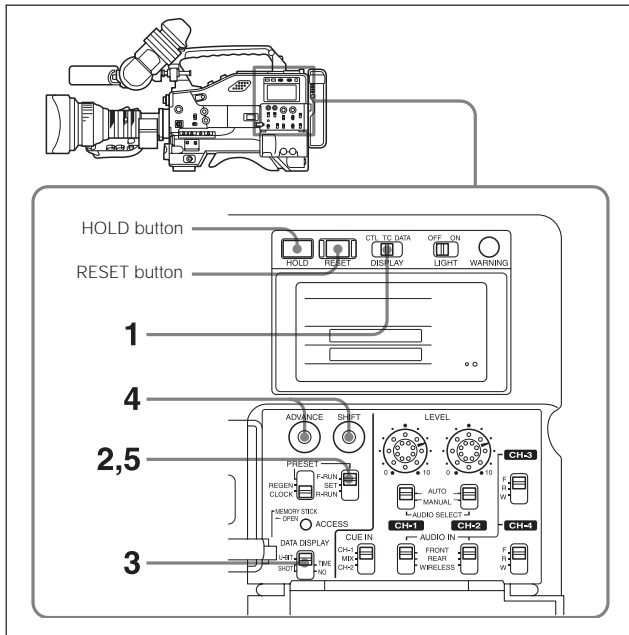

Setting the user bits

- 1 Set the DISPLAY switch to DATA.

(Continued)

- 2 Set the F-RUN/SET/R-RUN switch to SET.
- 3 Set the DATA DISPLAY switch to U-BIT.
- 4 Set the user bits by using the SHIFT and ADVANCE buttons.

SHIFT: Selects a digit to set. Each time you press the button, the flashing digit moves one column to the right.
Pressing this button while holding down the HOLD button moves the flashing digit one to the left.

ADVANCE: Increments the value of the flashing digit.
Pressing this button while holding down the HOLD button decrements the flashing digit.

Hexadecimal digits A to F are displayed as follows:

Hexadecimal	A	B	C	D	E	F
Display	<i>A</i>	<i>b</i>	<i>C</i>	<i>d</i>	<i>E</i>	<i>F</i>

Resetting a modified numeric value to 00:00:00:00

To reset a numeric value that was modified, press the RESET button.

- 5 Set the F-RUN/SET/R-RUN switch to F-RUN or R-RUN, corresponding to the desired time code run mode.

The specified user bits will be recorded for both LTC and VITC.

To store the user bits in memory

The user bits setting (apart from the real time) is automatically retained in memory even when the power is turned off.

4-5-4 Synchronizing the Time Code

You can synchronize the internal time code generator of this camcorder with an external generator for the regeneration of an external time code. You can also synchronize the time code generators of external VTRs with the internal generator of this camcorder.

Connections for time code synchronization

Connect both the reference video signal and the external time code as illustrated below.

Example 1: Synchronizing with an external time code

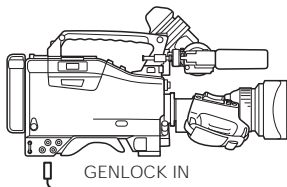

Reference video signal ^{a)}

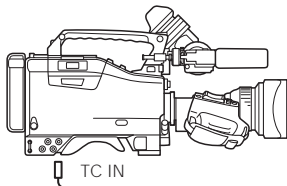

External time code

- a) In addition to the HD-Y signal, the NTSC composite video signal can be input as the reference video signal.

Example 2: Interconnecting a number of camcorders for time code synchronization

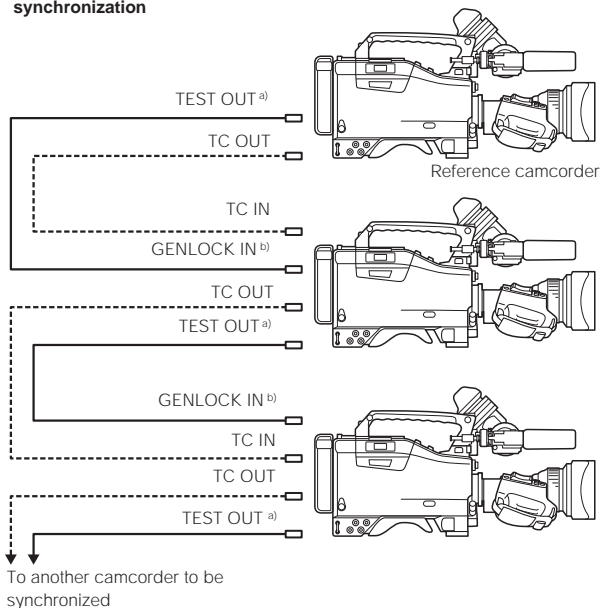

- a) When an HKDW-702 (not supplied) is installed, the down-converted video signal of the camcorder cannot be used as the reference signal. When interconnecting a number of camcorders, output the HD analog component signal (HD-Y signal) from the TEST OUT connector. For details, see "4-8-2 Selecting the Output Signals" on page 4-101.
- b) Set GENLOCK to ON on the GENLOCK page of the MAINTENANCE menu.

Procedure for time code synchronization

Follow the procedure below to synchronize the time code.

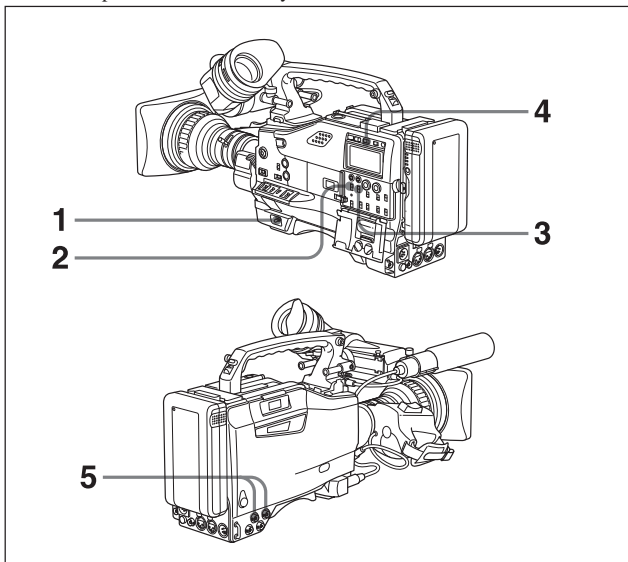

Synchronizing the time code

- 1** Turn the POWER switch to ON.
- 2** Set the PRESET/REGEN/CLOCK switch to PRESET.
- 3** Set the F-RUN/SET/R-RUN switch to F-RUN.
- 4** Set the DISPLAY switch to TC.

(Continued)

-
- 5** Supply the time code and reference video signals that comply with the SMPTE time code standard and are in the proper phase relationship to the TC IN connector and to the GENLOCK IN connector respectively.

This operation synchronizes the internal time code generator with the external time code. After about 10 seconds, you can disconnect the external time code without losing the synchronization. However, the synchronization will be disrupted if you connect or disconnect the time code during recording.

Notes

- When you finish the above procedure, the time code is immediately synchronized with the external time code and the counter display will show the value of the external time code. However, wait for a few seconds until the sync generator stabilizes before recording.
- If the frequency of the reference video signal is not the same as the frame frequency of the camcorder, the camera cannot be correctly genlocked. In such a case, the time code is not correctly synchronized with the external time code.
- When GENLOCK ON/OFF is set to OFF on the GENLOCK page of the MAINTENANCE menu, the time code cannot be synchronized with the reference video signal. In this case, set GENLOCK ON/OFF to ON on the GENLOCK page of the MAINTENANCE menu.

User bit settings during time code synchronization

When the time code is synchronized, only the time data is synchronized with the external time code value. Therefore, the user bits can have their own settings for each camcorder. You can also synchronize the user bits with external user bit data.

For more information, refer to the Maintenance Manual.

To release the time code synchronization

First disconnect the external time code, then set the F-RUN/SET/R-RUN switch to R-RUN.

To change the power supply from the battery pack to an external power supply during time code synchronization

To maintain a continuous power supply, connect the external power supply to the DC IN connector before removing the battery pack. You may lose time code synchronization if you remove the battery pack first.

Camera synchronization during time code synchronization

During time code synchronization, the camera is genlocked to the reference video signal input from the GENLOCK IN connector.

When the NTSC/PAL composite video signal is input as the reference video signal, the genlock H-phase cannot be adjusted. Also, subcarrier of the down-converted signal (composite video signal) of the camcorder cannot be synchronized with external equipment when an HKDW-702 (not supplied) is installed.

4-6 Menu Display on the Viewfinder Screen

4-6-1 Menu Configuration

The following shows the configuration of menus that you can use to make various settings and adjustments.

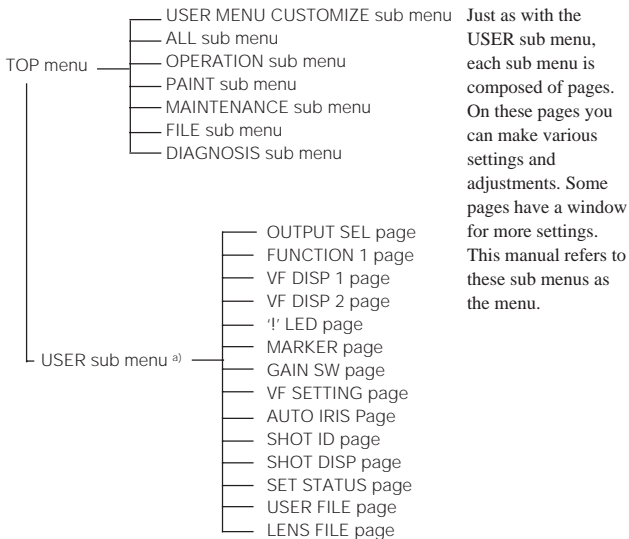

a) In this manual, the USER menu consisting of items and pages registered at the factory is used.

You use the USER MENU CUSTOMIZE menu to add or delete pages according to how the camcorder is being used.

For details, see “4-6-3 Editing the USER Menu” on page 4-55.

TOP menu

The menus of the camcorder are composed of submenus classified into categories according to the frequency of use, purpose of use and so on. The TOP menu allows you to select the desired submenus.

To display the TOP menu screen:

While holding down the MENU knob, set the MENU ON/OFF switch from the OFF position to the ON position.

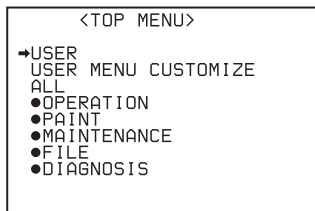

Note

The display of the TOP menu is inhibited according to AT circuit board switch settings inside the camcorder.

Refer to the Maintenance Manual for more information.

The TOP menu has the following submenus.

• USER menu:

This menu contains items for making settings or changing the settings needed to operate the camcorder. This menu is normally displayed when the MENU ON/OFF switch is changed to ON.

• USER MENU CUSTOMIZE menu:

This menu allows you to add the desired pages or delete them to suit your needs.

- **ALL menu:**

This menu contains all items of the OPERATION menu, PAINT menu, MAINTENANCE menu, FILE menu and DIAGNOSIS menu.

- **OPERATION menu:**

This menu contains items for changing settings according to conditions related to the subject when the camcorder is being operated.

- **PAINT menu**

This menu contains items for making detailed image adjustments while using a waveform monitor to monitor the waveforms output by the camera. Support of a video engineer is usually required to use this menu. Although you can also use an external remote control panel or master setup unit to set the items on this menu, this menu is effective when using the camcorder by itself outdoors.

- **MAINTENANCE menu**

This menu contains items for performing camera maintenance operations, such as changing the system or using infrequently used paint items.

- **FILE menu**

This menu is for performing file operations, such as writing the reference file.

- **DIAGNOSIS menu**

This menu enables you to confirm the VTR status or identify a failed circuit board.

To return to the TOP menu

The following two methods are available:

- Point the arrow (→) to TOP on the right top on each page, then press the MENU knob.
- Keep pushing the CANCEL/PRST / ESCAPE switch to the ESCAPE side until the TOP menu appears.

4-6-2 Basic Use of the Menu

When you open the cover, the MENU ON/OFF switch appears. If the MENU ON/OFF switch is set to ON, the USER menu is displayed on the viewfinder screen. Closing the cover automatically sets the MENU ON/OFF switch to OFF.

This section explains operations on the USER menu. If an HKDW-702 (not supplied) and/or HKDW-703 (not supplied) are not equipped with your camcorder, some of items on the USER menu pages are not displayed. But the operations are the same as those on menus other than the USER menu.

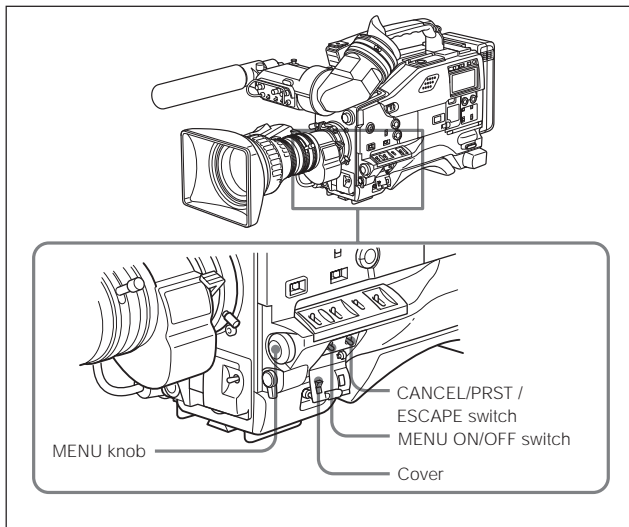

Controls for use of the basic use of the menu

- 1** Switch the MENU ON/OFF switch from OFF to ON.

The USER menu will be displayed.

02OFUNCTION1

ASSIGN SW <1>	:	EZ-FC
ASSIGN SW <2>	:	F.MIC
→FRONT MIC SELECT	:	● MONO
DF/NDF	:	DF
END SEARCH	:	OFF
LOOP/INTVAL REC	:	OFF

When the USER menu is first used, the CONTENTS page appears.

Follow the procedure below.

Or if you used the USER menu already, the page that was on the screen when the last USER menu operation ended appears on the viewfinder screen. In this case, go to step 2.

- ① Turn the MENU knob to move the → mark to desired page.

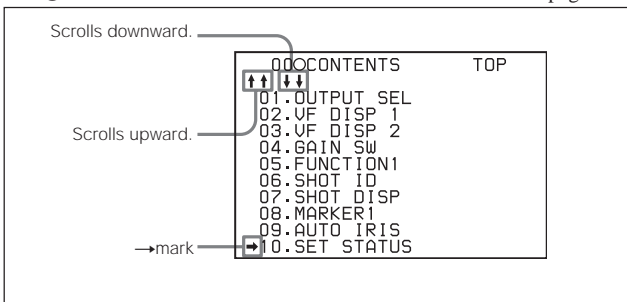

-
- ② Push the MENU knob.

The desired page is displayed. Start step 4.

- 2 Turn the MENU knob until the desired page appears.
- 3 Push the MENU knob.

The → mark appears at the left of the item currently selected on the page.

4

```
010OUTPUT SEL
→HD SDI OUT      :● OFF
REAR BNC OUT SEL: OFF
TEST OUT SELECT  : HD
DOWN CON MODE    : LETTR
```

- 4 Turn the MENU knob to move the → mark to the desired item.

Turning the MENU knob counterclockwise as seen from the front of the camera: Moves the → mark up continuously.

Turning the MENU knob clockwise as seen from the front of the camera: Moves the → mark down continuously.

(Continued)

5 Push the MENU knob.

The → mark at the left of the selected item changes to a ● mark and the ● mark at the left of the setting changes to a ? mark.

4

```
0100OUTPUT SEL
HD SDI OUT      : OFF
REAR BNC OUT SEL: OFF
TEST OUT SELECT : HD
●DOWN CON MODE  : ?LETR
```

6 Turn the MENU knob to change the settings.

To increase a setting value

Turn the MENU knob counterclockwise as seen from the front of the camera.

To decrease a setting value

Turn the MENU knob clockwise as seen from the front of the camera.

As turning the MENU knob, the setting increases or decreases one step by one step.

If you turn the knob quickly, the numeric value changes rapidly. If you turn it slowly, you can make minute adjustments.

To toggle a setting on or off

To select the ON setting, turn the MENU knob counterclockwise as seen from the front of the camera.

To select the OFF setting, turn the MENU knob clockwise as seen from the front of the camera.

To cancel the setting/to reset the setting to the initial setting

You can cancel the setting and reset it to its initial value (one set at the factory, or preset value) by pushing the CANCEL/PRST / ESCAPE switch to CANCEL/PRST before pushing the MENU knob in step 7.

When the CANCEL/PRST / ESCAPE switch is set to CANCEL/PRST, the message “CANCEL?” appears. To cancel the previous setting, push the CANCEL/PRST / ESCAPE switch to CANCEL/PRST again.

To reset the setting to the initial value, push the CANCEL/PRST / ESCAPE switch to CANCEL/PRST a third time. The message “PRESET?” appears. To reset to the initial setting, push the CANCEL/PRST / ESCAPE switch to CANCEL/PRST once more.

The action of the CANCEL/PRST function differs for some setting items. Some items are only affected by PRST. Check the setting procedure for each item for more information.

To interrupt changing the settings

By setting the MENU ON/OFF switch to OFF, the menu disappears from the viewfinder screen. By setting the MENU ON/OFF switch to ON again, the values that were displayed when you interrupted the setting operations will reappear so you can continue making settings.

7 Push the MENU knob.

The ● mark at the left of the selected item changes to a → mark and the ? mark at the left of the setting changes to a ● mark. The setting is executed.

8 To continue setting other items in the same page, repeat steps from 4 to 7.

To move to another page

- 1 Turn the MENU knob to move the → mark to the page number, then push the MENU knob.
Or, when the → mark is placed at a position other than the page number, push the CANCEL/PRST / ESCAPE switch to ESCAPE.

The ? mark appears in front of the page number. The camcorder is in page selecting mode.

- 2 Turn the MENU knob until the desired page appears.
- 3 Push the MENU knob when the desired page appears.

To end menu operations

You can end menu operations by the following two methods:

- Turn the MENU ON/OFF switch to OFF.
- Close the cover of the Menu Operating Section. When you close the cover, the MENU ON/OFF switch is set to OFF automatically.

The menu disappears from the viewfinder screen, and the display indicating the current status of the camcorder appears along the top and bottom of the viewfinder screen (when the viewfinder DISPLAY switch is set to ON or the VF DISP item on the VF DISP 1 page of the USER menu is set to ON).

For detailed information on the viewfinder display, see “4-7-2 Selecting the Display Items” on page 4-70.

4-6-3 Editing the USER Menu

The USER MENU CUSTOMIZE menu allows you to configure a USER menu that consists only of pages and items that you need by adding, deleting or replacing the pages. The USER 1 to USER 5 pages allow you to add, delete or replace the items.

Adding a new page

The USER MENU CUSTOMIZE menu allows you to add the new page to the USER menu.

On the USER 1 page, the items are already set at the factory. USER 2 to USER 5 pages are blank. You can register up to 10 items, including the blank row, on each page.

- 1 While holding down the MENU knob, change the MENU ON/OFF switch from the OFF position to the ON position.

The TOP menu appears.

- 2 Turn the MENU knob to move the → mark to USER MENU CUSTOMIZE, then push the MENU knob.

When the USER MENU CUSTOMIZE menu is first used, the CONTENTS page appears. Follow the procedure below.
Or if you have already used the USER MENU CUSTOMIZE menu, the page that was on the screen when the last USER MENU CUSTOMIZE menu operation ended appears on the viewfinder screen.

(Continued)

- 3** When the CONTENTS page is displayed, turn the MENU knob to move the → mark to one of USER 2 to USER 5, then push the MENU knob.

When another page is displayed, turn the MENU knob until the desired page of USER 2 to USER 5 appears, then push the MENU knob.

Example: When you select the USER 2 page

4

```
? 030USER2 EDIT
→Add New Item
```

- 4** After confirming the → mark at the left of Add New Item, push the MENU knob.

The page on which you can add items appears.

```
270BLACK          ESC
  ●●● SELECT ITEM ●●●
→MASTER BLACK    : 0
R BLACK           : 0
B BLACK           : 0
MASTER FLARE     : 0
R FLARE           : 0
G FLARE           : 0
B FLARE           : 0
FLARE            : ON
HD TESTOUT SEL   : Y
```

5 Add the items.

- ① Turn the MENU knob until the page that has the desired items appears, then push the MENU knob.
- ② Turn the MENU knob to move the → mark to the desired item, then push the MENU knob.

The USER 2 page appears again. The newly added item is displayed and Add New Item is displayed under the new item.

- ③ Add the remaining items by repeating steps ① and ②. You can add up to 10 items on one page. When the 10th item is registered, Add New Item disappears.

Deleting items from a page

- 1 Turn the MENU knob to move the → mark to the item that you want to delete, then push the MENU knob.
- 2 Push the CANCEL/PRST / ESCAPE switch to CANCEL/PRST.

The message “DELETE ITEM OK?” appears.
- 3 Push the CANCEL/PRST / ESCAPE switch to CANCEL/PRST again.

The item is deleted.

Replacing items on the page

- 1 Turn the MENU knob to move the → mark to the item that you want to replace, then push the MENU knob.

The → mark at the left of the selected item changes to the ● mark.

- 2 Turn the MENU knob to move the → mark to the position where you want to move the item, then push the MENU knob.

4

```
? 020USER1 EDIT
      PUSH TO ITEM INSERT
→WHITE <B> CH      :   AWB
TEST OUT MENU      :   OFF
OFFSET WHITE <A> :   OFF
WARM COOL <A>    :  3200
COLOR FINE <A>   :    0
●MASTER BLACK    :    0
Add New Item
```

The item selected in step 1 moves to the position that you selected in step 2.

In the above example, MASTER BLACK is moved to the top and other items are moved down one at a time.

Inserting a blank row

Turn the MENU knob to move the → mark to the position where you want to insert a blank row, and keep pushing the MENU knob for about 1.5 seconds.

A blank row is inserted.

Keep pushing
the MENU knob
for about 1.5
seconds.

```
? 020USER1 EDIT
      PUSH TO ITEM INSERT
●MASTER BLACK      :      0
  WHITE <B> CH      :      AWB

      TEST OUT MENU :      OFF

  OFFSET WHITE <A> :      OFF
  WARM COOL <A>   :     3200
  COLOR FINE <A>  :      0
  Add New Item
```

```
? 020USER1 EDIT
      MASTER BLACK   :      0
→  WHITE <B> CH     :      AWB

      TEST OUT MENU :      OFF

  OFFSET WHITE <A> :      OFF
  WARM COOL <A>   :     3200
  COLOR FINE <A>  :      0
  Add New Item
```

In the above example, a blank row is inserted between MASTER BLACK and WHITE CH.

Note

You cannot insert a blank row on a page where 10 items have been already registered.

Adding/deleting/replacing pages

You can add a new page to the USER menu, delete a page from the USER menu or replace pages.

To add a page

- 1 While holding down the MENU knob, set the MENU ON/OFF switch from the OFF position to the ON position.

The TOP menu appears.

- 2 Turn the MENU knob to move the → mark to USER MENU CUSTOMIZE, then push the MENU knob.

When the USER MENU CUSTOMIZE menu is first used, the CONTENTS page appears. Follow the procedure below.

Or if you have already used the USER MENU CUSTOMIZE menu, the page that was on the screen when the last USER MENU CUSTOMIZE menu operation ended appears on the viewfinder screen.

- 3 Turn the MENU knob to move the → mark to EDIT PAGE, then push the MENU knob, when the CONTENTS page is displayed. When another page is displayed, turn the MENU knob until the EDIT PAGE appears, then push the MENU knob.

The EDIT PAGE appears.

```
010EDIT PAGE
→Add New Page
01.OUTPUT SEL
02.FUNCTION 1
03.VF DISP 1
04.VF DISP 2
05.'!'LED
06.MARKER 1
07.GAIN SW
08.VF SETTING
```

-
- 4** Turn the MENU knob to move the → mark to Add New Page, then push the MENU knob.

The REMAIN PAGE where you can select the page to be added appears.

```
          REMAIN PAGE      ESC
          ●●● SELECT PAGE ●●●
→00.USER 1
 01.USER 2
 02.USER 3
 03.USER 4
 04.USER 5
 05.FUNCTION 2
 06.VF DISP 1
 07.MARKER 2
 08.TEST & RET
 09.OFFSET WHT
```

- 5** Turn the MENU knob to move the → mark to the desired page, then push the MENU knob.

The selected page is added to the last page of the USER menu.

To cancel adding a page

Turn the MENU knob to move the → mark to ESC at the right top of the screen, then push the MENU knob.

The EDIT PAGE appears again.

To delete a page

- 1 Turn the MENU knob to move the → mark to the page to be deleted.
- 2 Push the CANCEL/PRST / ESCAPE switch to CANCEL/PRST.

The message “DELETE PAGE OK?” appears.

4

```
01OEDIT PAGE
      DELETE PAGE OK ?
Add New Page
01.OUTPUT SEL
02.FUNCTION 1
03.VF DISP 1
→04.VF DISP 2
05.'!'LED
06.MARKER 1
07.GAIN Sw
08.VF SETTING
09.USER 1
```

- 3 Push the CANCEL/PRST / ESCAPE switch to CANCEL/PRST again.

In the above example, the VF DISP 2 page is deleted.

To move a page

- 1 Turn the MENU knob to move the → mark to the page that you want to move.

The → mark at the left of the selected page changes to a ● mark. The message “PUSH TO PAGE INSERT” appears at the right top of the screen.

- 2 Turn the MENU knob to move the → mark to the position where you want to move the page selected in step 1.

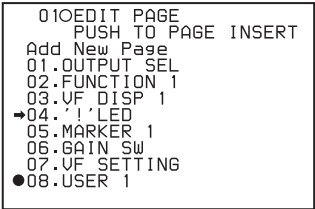

A screenshot of a menu screen with the following text:

```
01.OEDIT PAGE
   PUSH TO PAGE INSERT
Add New Page
01.OUTPUT SEL
02.FUNCTION 1
03.VF DISP 1
→04.'!'LED
05.MARKER 1
06.GAIN SW
07.VF SETTING
●08.USER 1
```

In the above example, USER 1 is inserted in the 04 position, and the ‘!’ LED page and pages after that move down one at a time after the operation in the following step 3 is completed.

- 3 Push the MENU knob.

The page selected in step 1 is moved to the position selected in step 2.

4-7 Status Display on the Viewfinder Screen

The viewfinder screen displays not only the video picture but also characters and messages indicating the camcorder settings and operating status, a center marker, a safety zone marker, etc.

When the MENU ON/OFF switch is set to OFF and the DISPLAY switch is set to ON, the items for which an “ON” setting was made in the VF DISP1 page of the USER menu or with related switches are displayed at the top and bottom of the screen. The messages that give details of the settings and adjustment progress and results can also be made to appear for about 3 seconds while settings are being changed, during adjustment, and after adjustment.

For information about the display item selection, see “4-7-2 Selecting the Display Items” on page 4-70. For information about setting change and adjustment progress messages, see “4-7-3 Display Mode and Setting Change and Adjustment Progress Messages” on page 4-73.

For information about marker display, see “4-7-4 Setting the Marker Display” on page 4-75.

4-7-1 Layout of the Status Display on the Viewfinder Screen

All items that can be displayed on the viewfinder screen are shown below.

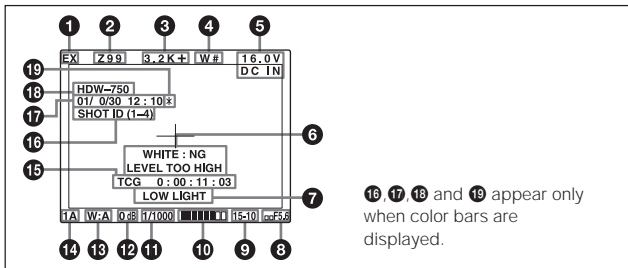

1 Extender

EX is displayed when a lens extender is used.

2 Zoom position indicator ¹⁾

This indicator indicates the approximate position of the variator ²⁾ of the zoom lens, between wide angle and telephoto.

3 Color temperature

This shows the currently selected color temperature.

4 UHF wireless microphone reception level

This shows reception level of the wireless microphone when the UHF wireless microphone is attached, using four ■ which appear at the right of “W”. When four ■ are lit, the receiving condition is good.

1) Zoom position indicator

This indicator appears only when you use a lens that has a zoom position display function.

2) Variator

A group of lenses that are moved to adjust the focal length.

5 DC IN/battery indicator

This shows the battery voltage of an internal battery pack or an external battery connected to the DC IN connector.

When the power is supplied from an external battery pack connected to the DC IN connector, DC IN appears.

When the DISP VOLT item is set to OFF on the VF DISP 2 page of the USER menu, the battery indicator does not appear, except when the Anton Bauer battery or BP-M50/M100 battery pack is used. The remaining battery capacity of those batteries is automatically detected and the battery indicator shows the detected remaining battery capacity as a percentage even when the DISP VOLT item is set to OFF. It changes in units of 10 %. Until the remaining battery capacity is reduced to 40 %, the indicators MAX, 90 %, 80 %...40 % are displayed for three seconds on the viewfinder each time the remaining battery capacity reduces by 10 %. When the remaining battery capacity is less than 40 %, this battery indicator is displayed all the time. When the remaining battery capacity is less than 10 % ^{a)}, the battery indicator blinks. When the remaining battery capacity is reduced further, the LOW indicator blinks.

a) This value can be set to either 10 % or 20 % on the FUNCTION 2 page of the OPERATION menu.

6 Setting change and adjustment progress message display area

For detailed information, see “4-7-3 Display Mode and Setting Change and Adjustment Progress Message” on page 4-73.

7 Operation/error message area

For detailed information, see “Operation/error messages” on page 6-15.

8 Iris setting/auto iris override

This indicator indicates the f-stop (iris setting) of the lens.

Also, the auto iris override is displayed using two ■ which appear in the upper and lower parts to the left of the F number respectively.

9 Remaining tape

This indicator indicates the remaining tape recording time (in minutes) of the VTR.

Example of remaining tape indicator

Display	Tape time remaining
F - 30	Full to 30 minutes
30 - 25	30 to 25 minutes
25 - 20	25 to 20 minutes
20 - 15	20 to 15 minutes
15 - 10	15 to 10 minutes
10 - 5	10 to 5 minutes
5 - 0	5 to 2 minutes
5 - 0 (flashing)	Less than 2 minutes

10 Audio level

These indicators indicate the level of audio channel 1 and channel 2. The peak indication of the VTR level meter is related as follows to the audio level when an 1-kHz sine wave is input.

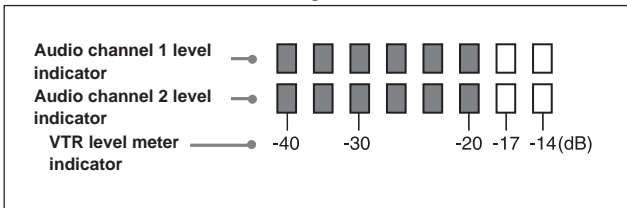

11 Shutter speed

This indicator indicates the shutter speed or the shutter mode. However, if the SHUTTER switch is set to OFF, nothing is displayed.

1/33, 1/60, 1/100, 1/125, 1/250, 1/500, 1/1000, 1/2000 Shutter speed (in seconds): in standard mode. ^{a)}

ECS: ECS mode

EVS: S-EVS mode

a) The available shutter speeds depend on the model. For details, see “4-2-1 Shutter Modes” on page 4-12.

12 Gain

This indicator indicates the gain (in dB) of the video amplifier, as set by the GAIN selector.

13 White balance memory

This indicator indicates the currently selected white balance automatic adjustment memory.

A: Displayed when the WHITE BAL switch is set to A.

B: Displayed when the WHITE BAL switch is set to B.

P: Displayed when the WHITE BAL switch is set to PRST or when the preset button on the RM-B150 has been pushed.

T: ATW is being used.

14 Filter

This indicator indicates the currently selected filter types.

15 Time code indicator

This indicates the time code, user bits or other information selected by the DISPLAY switch and DATA DISPLAY switch settings.

For more information, see “Relationships between the DISPLAY switch and DATA DISPLAY switch settings and the time counter displays” on page 2-45.

16 ID number indicator

This indicates the ID number selected from ID 1 to ID 4. This indicator is displayed when the color bars are displayed and recorded together with the color bars.

17 Date and time indicator

This shows the date and time of recording. This indicator is displayed when the color bars are displayed and recorded together with the color bars.

18 Model name and serial number indicator

This shows the model name and serial number of the camcorder. This indicator is displayed when the color bars are displayed and recorded together with the color bars.

19 * indicator

This blinks when the color bars are displayed and is recorded with the color bars.

4-7-2 Selecting the Display Items

To select the items to be displayed on the viewfinder screen from the VF DISP 1 and VF DISP 2 pages of the USER menu, turn on or off the indication next to each item.

Follow the procedure below to select the items to be displayed on the viewfinder screen.

4

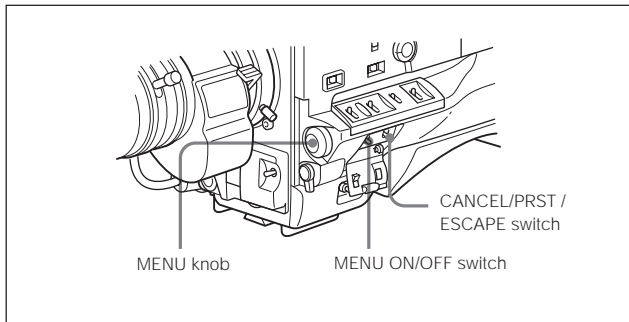

- 1 Set the MENU ON/OFF switch to ON.

The page that was on the screen when the last menu operation ended appears on the viewfinder screen.

- 2 Turn the MENU knob until the VF DISP 1 or VF DISP 2 page appears, and push the MENU knob.

The VF DISPLAY page appears.

The current settings of items appear to the right of each item.

030VF DISP 1		
→VF DISP	: ●	ON
VF DISPLAY MODE	:	3
DISP EXTENDER	:	ON
DISP FILTER	:	ON
DISP WHITE	:	ON
DISP GAIN	:	ON
DISP SHUTTER	:	ON
DISP AUDIO	:	ON
DISP TAPE	:	ON
DISP IRIS	:	ON

You can select the following items to be displayed on the viewfinder screen on the VF DISP 1 or VF DISP 2 page.

VF DISP 1 page

Item	Contents
VF DISP	ON or OFF of the viewfinder display ^{a)}
VF DISPLAY MODE	Selecting the display mode ^{b)}
DISP EXTENDER	Extender indicator
DISP FILTER	Types of the ND filter
DISP WHITE	White balance memory indicator
DISP GAIN	Gain indicator
DISP SHUTTER	Shutter speed and ECS mode indicator
DISP AUDIO	Audio level indicator
DISP TAPE	Remaining tape indicator
DISP IRIS	Iris opening indicator

a) The viewfinder display can be also turned on or off by pressing the DISPLAY switch on the viewfinder.

b) For detailed information on the display mode, see “4-7-3 Display Mode and Setting Change and Adjustment Progress Messages” on page 4-73.

(Continued)

VF DISP 2 page

Item	Contents
DISP ZOOM	Zoom position indicator
DISP COLOR TEMP	Displays the color temperature.
DISP VOLT ^{a)}	Displays the battery voltage of an internal battery pack or an external battery connected to the DC IN connector.
DISP DC IN	Displayed when the power is supplied from an external battery connected to the DC IN connector.
DISP WRR RF LVL	Displays the reception level of the wireless microphone.
DISP TIME CODE	Displays the time code.

a) When an Anton Bauer Intelligent Battery System or the BP-M50/M100 battery pack is used, the remaining battery capacity of those battery is displayed as a percentage when DISP VOLT is set to OFF.

- 3** Turn the MENU knob to move the → mark to the item you want to set, and push the MENU knob.

The → mark at the left of the selected item changes to a ● mark and the ● mark at the left of the setting changes to a ? mark.

- 4** Turn the MENU knob whether the selected item should appear in the viewfinder display (the “ON” setting), or not appear (the “OFF” setting), and push the MENU knob.

The ● mark at the left of the selected item changes to a → mark and the ? mark at the left of the setting changes to a ● mark.

Note that pushing the CANCEL/PRST / ESCAPE switch to CANCEL/PRST on this page has no effect.

- 5** To turn the setting of another item ON or OFF, repeat steps 3 and 4.
- 6** To end menu operations, set the MENU ON/OFF switch to OFF, or close the cover.

4-7-3 Display Mode and Setting Change and Adjustment Progress Messages

You can limit or suppress the messages that give details of setting changes and adjustment progress and results by setting a display mode. The conditions under which messages are displayed and their correspondence with the display mode are as follows:

Setting change and adjustment progress messages and display modes

Y: Message is displayed.

N: Message is not displayed.

Message display condition	Message	Display mode setting		
		1	2	3
When the filter selection has been changed	FILTER : n (where n = 1, 2, 3, 4)	N	N	Y
When the gain setting has been changed	GAIN : n (where n = -3dB, 0dB, 3dB, 6dB, 9dB, 12dB, 18dB, 24dB, 30dB, 36dB, 42dB)	N	N	Y
When the setting of the WHITE BAL switch has been changed	WHITE : n (where n = A CH, B CH, PRESET) or ATW : RUN	N	N	Y
When the OUTPUT/DCC selector has been set to DCC ON or OFF	DCC : ON (or OFF)	N	Y	Y
When the shutter speed and mode setting has been changed ^{a)}	: SS : 1/100 (for the 59.94I or 25PsF format model), 1/60 (for the 50I or 25PsF format model), or 1/33 or 1/50 (for 25PsF format model) (or 1/125, 1/250, 1/500, 1/1000, 1/2000, ECS, EVS)	N	Y	Y

(Continued)

Message display condition	Message	Display mode setting		
		1	2	3
When the black or white balance has been adjusted	E.g. WHITE : OK For more information, see Section "4-1 Adjusting the Black Balance and the White Balance" (page 4-1).	N	Y	Y

a) This is also displayed for about 3 seconds when the SHUTTER selector is set to ON.

Changing the display mode

The currently set display mode appears on the VF DISP 1 page of the USER menu. Follow the procedure below to change it.

1 Follow steps 1 to 2 in "4-7-2 Selecting the Display Items" (page 4-70), until the VF DISP 1 page of the USER menu is on the viewfinder screen.

2 Turn the MENU knob to move the → mark to VF DISPLAY MODE, and push the MENU knob.

The → mark at the left of the selected item changes to a ● mark and the ● mark at the left of the setting changes to a ? mark.

3 Turn the MENU knob until the desired display mode appears, and push the MENU knob.

The ● mark at the left of the selected item changes to a → mark and the ? mark at the left of the setting changes to a ● mark.

4 To end menu operations, set the MENU ON/OFF switch to OFF, or close the cover.

4-7-4 Setting the Marker Display

Use the MARKER page of the USER menu to switch the display of the center and safety zone markers on or off and to select whether the area indicated by the safety zone marker is 80%, 90% or 100% of the screen area.

Note

When an HKDW-702 is installed and the NTSC viewfinder and/or the NTSC monitor are connected, all markers and zebra patterns are not displayed if DOWN CON MODE is set to CROP on the OUTPUT SEL page of the USER menu, even if the marker display is set to ON.

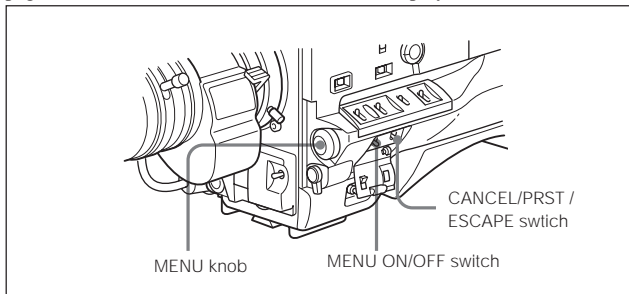

- 1 Set the MENU ON/OFF switch to ON.

The page that was on the screen when the last menu operation ended appears on the viewfinder screen.

- 2 Turn the MENU knob until the MARKER page appears, and push the MENU knob.

(Continued)

The current setting of an item appears to the right of the item.

060MARKER 1		
→MARKER	: ●	OFF
CENTER	:	OFF
CENTER MARK	:	3
SAFETY ZONE	:	OFF
SAFETY AREA	:	92.5%
ASPECT	:	OFF
ASPECT SELECT	:	4:3
ASPECT MASK	:	OFF
ASPECT MASK LVL	:	0
100% MARKER	:	OFF

You can select displaying or not-displaying for the following item.

Item	Contents
MARKER	Not to display all markers, set to OFF.
CENTER	To display the center marker, set to ON.
CENTER MARK	To select the type center marker (1 to 4), when CENTER is set to ON.
SAFETY ZONE	To display the safety zone, set to ON.
SAFETY AREA	To select the safety zone range (80%, 90%, 92.5 % or 95 %), when SAFETY ZONE is set to ON.
ASPECT	To display the aspect marker, set to ON.
ASPECT SELECT	To select the aspect mode.
ASPECT MASK	To make the areas out of the selected aspect marker dimmer, set to ON.
ASPECT MASK LVL	To set the mask level (0 to 8), when the ASPECT MASK is set to ON.
100 % MARKER	To display the effective pixel area, set to ON.

3 Perform the settings for each item.

- ① Turn the MENU knob to move the → mark to the item you want to set, and push the MENU knob.

The → mark at the left of the selected item changes to a ● mark and the ● mark at the left of the setting changes to a ? mark.

- ② Turn the MENU knob to change the desired setting, and push the MENU knob.

The ● mark at the left of the selected item changes to a → mark and the ? mark at the left of the setting changes to a ● mark.

Note that the CANCEL/PRST / ESCAPE function can be used for the ASPECT MASK LVL item.

If the CANCEL/PRST / ESCAPE switch is pressed twice to CANCEL/PRST before pushing the MENU knob in step ②, the previous setting is canceled. If the switch is pressed twice more to CANCEL/PRST, the setting is reset to its initial value.

4 To continue setting other items, repeat step 3.

5 To end menu operations, set the MENU ON/OFF switch to OFF, or close the cover.

4-7-5 Setting the Viewfinder

Use the VF SETTING page of the USER menu to select items related to the viewfinder.

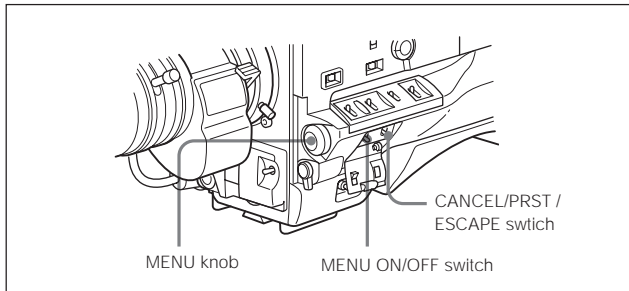

- 1 Set the MENU ON/OFF switch to ON.

The page that was on the screen when the last menu operation ended appears on the viewfinder screen.

- 2 Turn the MENU knob until the VF SETTING page appears, and push the MENU knob.

The VF SETTING page appears.

The current setting of an item appears to the right of the item.

080UF SETTING	
→ZEBRA	: ● OFF
ZEBRA SELECT	: 1
ZEBRA1 DET. LVL	: 0
ZEBRA2 DET. LVL	: 0
ASPECT	: OFF
VF DETAIL LEVEL	: 0
VF DTL H LEVEL	: 0
VF DTL V LEVEL	: 0

Item	Content
ZEBRA	Turns the zebra display on or off. ^{a)}
ZEBRA SELECT	Selects ZEBRA 1, ZEBRA 2 or BOTH.
ZEBRA 1 DET. LVL	Adjusts the level of the zebra 1 (70%) display.
ZEBRA 2 DET. LVL	Adjusts the level of the zebra 2 (100%) display.
ASPECT	Turns the aspect MARKER display on or off.
VF DETAIL LEVEL	Adjusts the sharpness in the viewfinder (–99 to 0 to 99). ^{b)} Turns the VF detail function on or off and adjusts the level.
VF DTL H LEVEL	Adjusts the VF H detail. ^{b)} (–99 to 0 to 99).
VF DTL V LEVEL	Adjusts the VF V detail. ^{b)} (–99 to 0 to 99).

- a) When you use the viewfinder which is not equipped with the ZEBRA switch, turns the display on or off using this item. When you use the viewfinder with the ZEBRA switch, the latest operation between the ZEBRA switch and this menu operation is effective.
- b) The sharpness setting in the viewfinder does not affect the recorded image.

(Continued)

-
- 3** Turn the MENU knob to move the → mark to the item you want to set, and push the MENU knob.

The → mark at the left of the selected item changes to a ● mark and the ● mark at the left of the setting changes to a ? mark.

- 4** Turn the MENU knob to change the desired setting, and push the MENU knob.

The ● mark at the left of the selected item changes to a → mark and the ? mark at the left of the setting changes to a ● mark.

- 5** To continue setting other items, repeat steps **3** and **4**.

- 6** To end menu operations, turn the MENU ON/OFF switch to OFF, or close the cover.

4-7-6 Recording Superimposed Shot Data in Color Bars

In the SHOT DISP page of the USER menu, you can select which shot data is recorded superimposed on the color bars. You can also select which of the shot IDs (1 to 4) set in the SHOT ID page is recorded superimposed on the picture.

Use the following procedure.

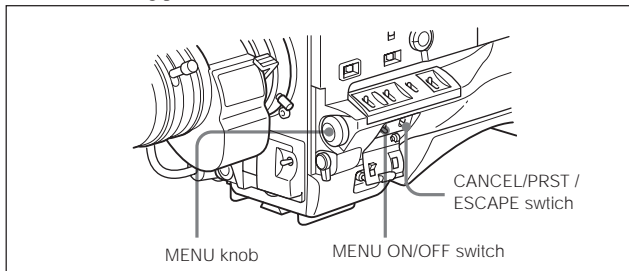

Selecting the shot data for superimposed recording

- 1 Set the MENU ON/OFF switch to ON.

The page that was on the screen when the last menu operation ended appears on the viewfinder screen.

- 2 Turn the MENU knob until the SHOT DISP page appears, and push the MENU knob.

(Continued)

The SHOT DISP page appears.

The current setting of an item appears to the right of the item.

110SHOT DISP		
→SHOT DATE	: ●	OFF
SHOT TIME	:	OFF
SHOT MODEL NAME	:	OFF
SHOT SERIAL NO	:	OFF
SHOT ID SEL	:	OFF
SHOT BLINK CHARA:		OFF

Item	Content
SHOT DATE	Selects whether or not the shot data is superimposed (ON or OFF).
SHOT TIME	Selects whether or not shot time is superimposed (ON or OFF).
SHOT MODEL NAME	Selects whether or not the model name is superimposed (ON or OFF).
SHOT SERIAL NO	Selects whether or not the serial number is superimposed (ON or OFF).
SHOT ID SEL	Selects whether or not the shot ID set in the SHOT ID page is superimposed (1 to 4 or OFF). ^{a)}
SHOT BLINK CHARA	Selects whether or not the blinking * is superimposed (ON or OFF).

- a) To carry out superimposed recording, select the SHOT ID number (1 to 4). Not to carry out superimposed recording, select OFF.

-
- 3** Turn the MENU knob to move the → mark to the item you want to set, and push the MENU knob.

The → mark at the left of the selected item changes to a ● mark and the ● mark at the left of the setting changes to a ? mark.

- 4** Turn the MENU knob to select whether or not to record the selected item superimposed on the picture, and push the MENU knob.

The ● mark at the left of the selected item changes to a → mark and the ? mark at the left of the setting changes to a ● mark.

- 5** To continue setting other items, repeat steps 3 and 4.

- 6** To end menu operations, turn the MENU ON/OFF switch to OFF, or close the cover.

To carry out superimposed recording

To actually record the items selected for superimposed recording in the SHOT DISP page, set the OUTPUT/DCC switch to BARS, DCC OFF. The items selected for superimposed recording appear in the viewfinder screen and are recorded superimposed on the picture.

4-7-7 Setting the Shot ID

In the SHOT ID page of the USER menu, you can set a shot ID of up to 12 alphanumeric characters, spaces, and symbols.

When the OUTPUT/DCC switch is set to BARS, DCC OFF, this shot ID is output with the color bar signal. The shot ID comprises ID1 to ID4, and the setting can be changed using the SHOT DISP page of the USER menu.

Note

When the menu is displayed, the shot ID is not displayed even if the color bar signal is output.

Follow the procedure below to set the shot ID.

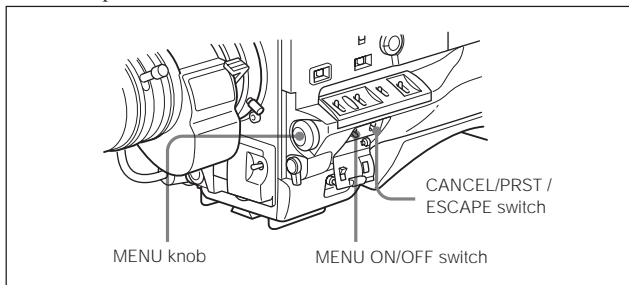

Setting the shot ID

- 1 Set the MENU ON/OFF switch to ON.

The page that was on the screen when the last menu operation ended appears on the viewfinder screen.

- 2** Turn the MENU knob until the SHOT ID page appears, and push the MENU knob.

```
100SHOT ID
→ID-1 : SHOT-IS NAME
ID-2 : 00000000000000
ID-3 : 00000000000000
ID-4 : 00000000000000
```

- 3** Turn the MENU knob to move the → mark to the ID (one of ID-1 to ID-4) you want to set, and push the MENU knob.

The window for entering the shot ID appears.

The ↓ mark appears over the top of the character on the character entry row. You can now enter the characters (character setting mode).

```
          ID-1          ESC
↓
■SHOT-IS NAME■          END
          ABCDEFGHIJKLMNOPQRSTUVWXYZ
          XYZ 0123456789 !#$%&()*+
          ,-. / : ; < = > ? @
          RET INS DEL
```

(Continued)

4 Enter or change the shot ID.

When you enter the shot ID first, go to step ②.

- ① Turn the MENU knob to move the ↓ mark to the character which you want to change, then push the MENU knob.

The ↓ mark changes to the ? mark and the character table appears.

The ↓ mark moves to the character table.

```

ID-1                               ESC
      ?
■SHOT-IS NAME■                     END
      ↓
      ABCDEFGHIJKLMNOPQRSTUVWXYZ
      XYZ 0123456789 !#$%&()*+
      ,-. / : ; < = > ? @
                               RET INS DEL
```

- ② Turn the MENU knob until the ↓ mark moves to the character position that you want to select, then push the MENU knob.

Example: To change the "S" to "D"

Move the ↓ mark to D.
D appears under the ? mark.

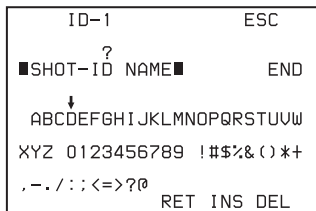

Push the MENU knob.
The ? mark changes to the ↓ mark.

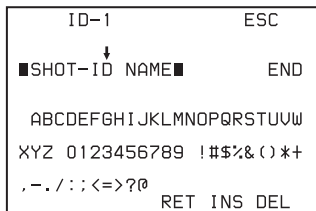

(Continued)

To enter a space

Move the ↓ mark over the INS, then push the MENU knob. The space is entered in the position under the ? mark on the character entry row.

When there is a character under the ? mark, the space is entered in that position, and that and subsequent characters move to the right one at a time.

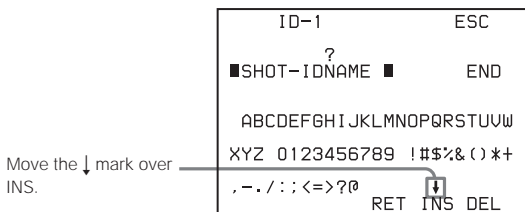

Push the MENU knob.

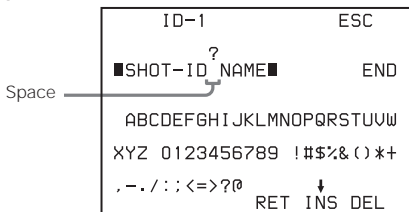

Move the ↓ mark over RET, then push the MENU knob. The ? mark over the space on the character entry row changes to a ↓ mark.

To delete a character

Move the ↓ mark over DEL, then push the MENU knob. The character under the ? mark is deleted and the subsequent characters move to the left one at a time.

To cancel deleting the character

Move the ↓ mark over RET, then push the MENU knob. The ? mark on the character entry row changes to a ↓ mark.

- 5 Repeat step 4 to enter remaining characters.
- 6 When you finish entering characters, turn the MENU knob to move the ↓ mark over END, then push the MENU knob.

The character setting mode is cleared and the SHOT ID page appears.

To cancel entering or changing shot ID

Before performing step 6 operations, move the → mark to ESC at top right of the window, then push the MENU knob.

All changes or entered characters are discarded and the SHOT ID page appears.

4-7-8 Displaying the Status Confirmation Windows

You can confirm the settings or status of the camcorder on the viewfinder screen by displaying the following windows.

- ABNORMAL <!> window
- FUNCTION window
- AUDIO STATUS window
- GPS window (only when an HKDW-704 GPS UNIT is attached)

For detailed information on the GPS window, refer to the OPERATION MANUAL supplied with an HKDW-704.

ABNORMAL <!> window

ABNORMAL <!>		
!GAIN	: ON	12dB
!SHUTTER	: ON	EVS
WHT PRESET	: ON	WB
ATW RUN	: ON	OFF
EXTENDER	: ON	OFF
!FILTER	: OFF	2
OVERRIDE	: ON	0

This window allows you to confirm why the **!** (warning) indicator lights. You can use the '**!**' LED page of the USER menu to set whether or not the **!** (warning) indicator lights.

FUNCTION window

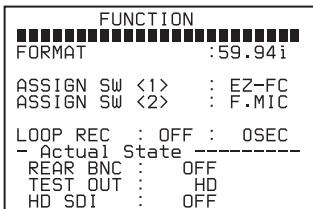

This menu is for a camcorder which operates with 59.94i format.

This window allows you to confirm the assigned function of the ASSIGN 1/2 switches, ON/OFF of the Loop Rec function, ON/OFF of the output, the output signal of BNC connectors (HD SDI connector, VBS/SDI OUT connector and TEST OUT connectors) and the currently selected format.

AUDIO STATUS window

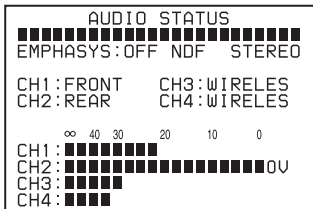

This window allows you to confirm the following items related to audio.

- ON/OFF of EMPHASIS, setting conditions of DF/NDF (only for an HDW-730 operating with 59.94I format and the HDW-750) and FRONT MIC MONO/STEREO
- Type of input signal to audio channels CH1/CH2/CH3/CH4
- Input level of audio channels CH1/CH2/CH3/CH4

Display/don't display status confirmation windows

You can use the SET STATUS page of the USER menu to set whether or not the status confirmation windows are displayed.

To display the status confirmation windows

You can use the CANCEL/PRST / ESCAPE switch as the STATUS ON/SEL / OFF switch when the MENU ON/OFF switch is set to OFF (when the cover is closed, OFF is automatically selected).

4

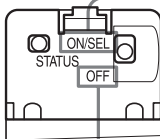
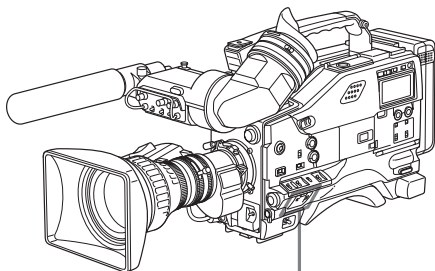

By pushing the STATUS ON/SEL / OFF switch up to ON/SEL, the confirmation window appears.

Each time you push this switch up to ON/SEL, the window switches. After 10 seconds, the window disappears automatically.

To disappear the window promptly after displaying the window, push this switch down to OFF.

To disable display of the status confirmation windows

- 1 Set the MENU ON/OFF switch to ON.

The page that was on the screen when the last menu operation ended appears on the viewfinder screen.

- 2 Turn the MENU knob until the SET STATUS page appears, and push the MENU knob.

The SET STATUS page appears.

The current setting of an item appears to the right of the item.

120SET STATUS			
→STATUS	ABNORMAL	: ●	ON
	STATUS	FUNCTION	: ON
	STATUS	AUDIO	: ON
	GPS	:	ON

Item	Content
ABNORMAL	Selects whether or not the ABNORMAL window is displayed (ON or OFF).
FUNCTION	Selects whether or not the FUNCTION window is displayed (ON or OFF).
STATUS AUDIO	Selects whether or not the STATUS AUDIO window is displayed (ON or OFF).
GPS ^{a)}	Selects whether or not the GPS window is displayed (ON or OFF).

- a) When the HKDW-704 (not supplied) is installed, this item appears. For the GPS window, refer to the Operation Manual supplied with an HKDW-704.

(Continued)

-
- 3** Turn the MENU knob to move the → mark to the item you want to set, and push the MENU knob.

The → mark at the left of the selected item changes to a ● mark and the ● mark at the left of the setting changes to a ? mark.

- 4** Turn the MENU knob to select whether or not to DISPLAY the selected window, then push the MENU knob.

The ● mark at the left of the selected item changes to a → mark and the ? mark at the left of the setting changes to a ● mark.

- 5** To continue setting other windows, repeat steps 3 and 4.

- 6** To end menu operations, turn the MENU ON/OFF switch to OFF, or close the cover.

4-7-9 Confirming the Image of the Return Video Signal on the Viewfinder

You can set whether or not the image of the return video signal is displayed on the viewfinder, using the GENLOCK page of the MAINTENANCE menu.

- 1** Set the MENU ON/OFF switch to ON while pushing the MENU knob.

The TOP menu appears.

- 2** Turn the MENU knob to move the → mark to MAINTENANCE, then push the MENU knob.

When the MAINTENANCE menu is first used, the CONTENTS page appears.

Or if you used the MAINTENANCE menu already, the page that was on the screen when the last MAINTENANCE menu operation ended appears on the viewfinder screen.

- 3** When the CONTENTS page is displayed, turn the MENU knob to move → mark to GENLOCK, then push the MENU knob. When any page of the MAINTENANCE menu is displayed, turn the MENU knob until the GENLOCK page appears, then push the MENU knob.

The GENLOCK page appears, and the current settings are displayed on the page.

```
? 150GENLOCK
GENLOCK          :    ON
RETURN VIDEO     :    OFF
GL H PHASE COARSE :    0
GL H PHASE FINE  :    0
```

(Continued)

4 Perform the following setting.

- ① Turn the MENU knob to move the → mark to GENLOCK, and push the MENU knob.

The → mark at the left of GENLOCK setting changes to a ● mark and the ● mark at the left of GENLOCK setting changes to a ? mark.

- ② Turn the MENU knob until OFF appears, then push the MENU knob.

The ● mark at the left of GENLOCK changes to a → mark and the ? mark at the left of GENLOCK setting changes to a ● mark.

And the setting is executed.

- ③ Turn the MENU knob to move the → mark to RETURN VIDEO, and push the MENU knob.

The → mark changes to a ● mark and the ● mark changes to a ? mark.

- ④ Turn the MENU knob until ON appears, then push the MENU knob.

The ● mark changes to the → mark and the ? mark changes to a ● mark.

And the setting is executed.

5 To end the menu operation, set the MENU ON/OFF switch to OFF, or close the cover.

To see the image of the return video signal on the viewfinder screen

Press the RET switch on the lens. The image of the return video signal input in to the GENLOCK IN connector is displayed on the viewfinder screen while you are pressing the RETURN switch on the lens.

When the RETURN VIDEO function is assigned to the ASSIGN 1 switch, you can see the image of the return video signal on the viewfinder screen while you are pressing the ASSIGN 1 switch even if RETURN VIDEO is set to OFF on the GENLOCK page of the MAINTENANCE menu.

Note

When any signal is not input to the GENLOCK IN connector, the image is not changed even if you press the RET switch on the lens.

However, the image is switched while you are pressing the ASSIGN 1 switch to which the RETURN VIDEO function is assigned, even if any signal is not input to the GENLOCK IN connector.

4-8 Adjustments and Settings from Menus

The camcorder provides menus for adjustments and settings.

4-8-1 Setting the GAIN Selector Values

Before using the camcorder, use the GAIN SW page of the USER menu to set the gains corresponding to the L, M, and H positions of the GAIN selector, which switches the gain of the video amplifier.

4

Follow the procedure below to set the gain.

- 1 Set the MENU ON/OFF switch to ON.

The page that was on the screen when the last menu operation ended appears on the viewfinder screen.

- 2 Turn the MENU knob until the GAIN SW page appears, and push the MENU knob.

The GAIN SW page appears.

The current setting of an item appears to the right of the item.

070GAIN SW	
→GAIN LOW	: ● 0dB
GAIN MID	: 6dB
GAIN HIGH	: 12dB
GAIN TURBO	: 42dB
TURBO SW IND	: OFF

Item	Content
GAIN LOW	Sets the gain value corresponding to the L position of the GAIN selector.
GAIN MID	Sets the gain value corresponding to the M position of the GAIN selector.
GAIN HIGH	Sets the gain value corresponding to the H position of the GAIN selector.
GAIN TURBO	Sets the gain value corresponding to TURBO GAIN button selection.
TURBO SW IND	OFF: When you operate the GAIN switch after pressing the TURBO GAIN button once, the video gain is changed according to the GAIN switch operation. ON: When the video gain is boosted to the video gain to the value preset by pressing the TURBO GAIN button once, the video gain is not changed even if you operate the GAIN switch if you do not press the TURBO GAIN button once more.

(Continued)

-
- 3** Turn the MENU knob to move the → mark to the item you want to set, and push the MENU knob.

The → mark at the left of the selected item changes to a ● mark and the ● mark at the left of the setting changes to a ? mark.

- 4** Turn the MENU knob to change the desired setting, and push the MENU knob.

The ● mark at the left of the selected item changes to a → mark and the ? mark at the left of the setting changes to a ● mark.

Any of -3, 0, 3, 6, 9, 12, 18, 24, 30, 36 or 42 dB can be set for each of the L, M, and H positions, in any sequence.

For TURBO, any of -3, 0, 3, 6, 9, 12, 18, 24, 30, 36 or 42 dB can be selected.

To change the gain corresponding to another switch position, return to step 3.

- 5** To end menu operations, turn the MENU ON/OFF switch to OFF, or close the cover.

4-8-2 Selecting the Output Signals

The OUTPUT SEL page of the USER menu allows you to select the type of video signals from the VBS/SDI OUT connector and the TEST OUT connector (these settings are effective only when the HKDW-702 is installed). You can also set whether or not the video signal is output from the HD SDI OUT connector.

Follow the procedure below to select the output signal.

- 1 Set the MENU ON/OFF switch to ON.

The page that was on the screen when the last menu operation ended appears on the viewfinder screen.

- 2 Turn the MENU knob until the OUTPUT SEL page appears, and push the MENU knob.

The OUTPUT SEL page appears.

The current setting of an item appears to the right of the item.

```
010OUTPUT SEL
→HD SDI OUT      : ● OFF
REAR BNC OUT SEL : OFF
TEST OUT SELECT  : HD
DOWN CON MODE    : LETTR
```

(Continued)

Item	Content
HD SDI OUT	Sets whether or not the video signal is output from the HD SDI OUT connector. When OFF is selected, the HD SDI circuit is disconnected, which saves power.
REAR BNC OUT SEL ^{a)}	Selects the type of the video signal to be output from the VBS/SDI OUT connector (one of VBS/SDI ^{b)} /OFF). When OFF is selected, the down converter stops. This saves power. ^{c)}
TEST OUT SELECT ^{a)}	Selects the type of the video signal to be output from the TEST OUT connector. When HD is selected, the HD-Y signal is output. When SD is selected, the down-converted color composite signal is output. ^{d)}
DOWN CON MODE ^{a)}	Selects the conversion mode of the down converter among SQUEZE, LETTR and CROP. SQUEZE: The picture is displayed without distortion on a monitor with the 16:9 aspect ratio. On a monitor with the 4:3 aspect ratio, the picture is distorted horizontally. LETTR: Displays the picture without distortion on a monitor with the 4:3 aspect ratio, the video signal of the 16:9 aspect ratio is output by adding a blank area (no signal, black) top and bottom. CROP ^{e)} : Cropping both the left and right sides of a video image with the 16:9 aspect ratio, a video signal with the 4:3 aspect ratio is output.

- a) When an HKDW-702 (not supplied) is not installed, these items are not displayed on the OUTPUT SEL page.

- b) When SDI is selected, connect the VBS/SDI OUT connector to the SDI IN connector of the monitor.
When VBS is selected, connect the VBS/SDI OUT connector to the VIDEO IN connector of the monitor.
- c) If you connect the TEST OUT connector to the monitor by setting TEST OUT SELECT to SD, the down converter automatically operates even if REAR BNC OUT SEL is set to OFF.
- d) When no picture is displayed on the monitor with the TEST OUT connector feeding the monitor, make sure the type of monitor (HD monitor / NTSC/PAL monitor) and the signal format of the output signal of the camcorder (1080i/525i/625i) match.
- e) When the NTSC/PAL viewfinder or NTSC/PAL monitor is connected, the markers and zebra patterns are not displayed when CROP is selected.

- 3** Turn the MENU knob to move the → mark to the item you want to set, and push the MENU knob.

The → mark at the left of the selected item changes to a ● mark and the ● mark at the left of the setting changes to a ? mark.

- 4** Turn the MENU knob to change the desired setting, and push the MENU knob.

The ● mark at the left of the selected item changes to a → mark and the ? mark at the left of the setting changes to a ● mark.

To continue the setting of another output signal, repeat steps 3 and 4.

- 5** To end menu operations, turn the MENU ON/OFF switch to OFF, or close the cover.

4-8-3 Setting the Color Temperature Manually

You can adjust the value of the white balance manually by setting the color temperature.

The WHITE page of the PAINT menu allows you to do this setting.

- 1 Follow the procedure of steps 1 to 3 described in “4-7-9 Confirming the Image of the Return Video Signal on the Viewfinder” on page 4-94 to display the WHITE page of the PAINT menu.

The WHITE page appears.

The current setting of an item appears to the right of the item.

02OWHITE		
→COLOR TEMP.	<A>: ●	3200
COLOR FINE	<A>:	0
R GAIN	<A>:	0
B GAIN	<A>:	0
COLOR TEMP.	:	3200
COLOR FINE	:	0
R GAIN	:	0
B GAIN	:	0

Item	Content
COLOR TEMP <A>	Sets the color temperature for the desired value. Adjust the value while looking at the real image because error tends to be bigger for adjustment of high color temperature.
COLOR FINE <A>	Adjusts the value more precisely when the color temperature adjustment through COLOR TEMP is not satisfactory.
R GAIN <A>	Only the value of R GAIN is changed.
B GAIN <A>	Only the value of B GAIN is changed.

The above table shows the adjustment of the white balance of channel A.

The items to which is attached are used to adjust the white balance of channel B.

- Turn the MENU knob to move the → mark to the item you want to set, and push the MENU knob.

The → mark at the left of the selected item changes to a ● mark and the ● mark at the left of the setting changes to a ? mark.

- Turn the MENU knob to change the desired setting, and push the MENU knob.

The ● mark at the left of the selected item changes to a → mark and the ? mark at the left of the setting changes to a ● mark.

To continue another setting, repeat steps 2 and 3.

- To end menu operations, turn the MENU ON/OFF switch to OFF, or close the cover.

4-8-4 Specifying an Offset for the Auto White Balance Setting

By setting an offset for the value of auto white balance, you can make the picture warmer or colder.

The OFFSET WHT page of the OPERATION menu allows you to do this setting.

4

- 1 Follow the procedure of steps 1 to 3 described in “4-7-9 Confirming the Image of the Return Video Signal on the Viewfinder” on page 4-94 to display the OFFSET WHT page of the OPERATION menu.

The OFFSET WHT page appears.

The current setting of an item appears to the right of the item.

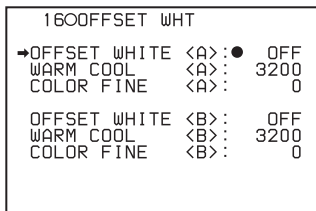

Item	Content
OFFSET WHITE <A>	Turns the setting of the offset for channel A ON or OFF. ON: Adds the offset adjusted on this page to the white balance.
WARM-COOL <A>	Sets the offset for the white balance of channel A, using the color temperature. Adjust the value while looking at the real image because error tends to be bigger for adjustment of high color temperature.
COLOR FINE <A>	Adjusts the value more precisely if the adjustment by WARM-COOL <A> is not satisfactory.
OFFSET WHITE 	Turns the setting of the offset for channel B ON or OFF. ON: Adds the offset adjusted on this page to the white balance.
WARM-COOL 	Sets the offset for the white balance of channel B, using the color temperature. Adjust the value while looking at the real image because error tends to be bigger for adjustment of high color temperature.
COLOR FINE 	Adjusts the value more precisely if the adjustment by WARM-COOL is not satisfactory.

- 2** Set the WHITE BAL switch to the position corresponding to the desired channel (A or B).

Note

If the WHITE BAL switch is not set to A or B when you operate the camcorder, the adjustment value will not be reflected in the output signal.

(Continued)

-
- 3** Turn the MENU knob to move the → mark to the item you want to set, and push the MENU knob.

The → mark at the left of the selected item changes to a ● mark and the ● mark at the left of the setting changes to a ? mark.

- 4** Turn the MENU knob to change the desired setting, and push the MENU knob.

The ● mark at the left of the selected item changes to a → mark and the ? mark at the left of the setting changes to a ● mark.

- 5** To continue another setting, repeat steps **3** and **4**.
To continue the settings of the other white balance channel, go back to step 2.
- 6** To end menu operations, set the MENU ON/OFF switch to OFF, or close the cover.

4-8-5 Assigning Functions to ASSIGN 1/2 Switches

You can assign the desired function to ASSIGN 1 and 2 switches.

- 1 Set the MENU ON/OFF switch to ON.

The page that was on the screen when the last menu operation ended appears on the viewfinder screen.

- 2 Turn the MENU knob until the FUNCTION 1 page appears, and push the MENU knob.

The FUNCTION 1 page appears.

The current setting of an item appears to the right of the item.

02OFUNCTION1	
→ASSIGN SW <1>	:⇒EZ-FC
ASSIGN SW <2>	: F.MIC
FRONT MIC SELECT:	MONO
DF/NDP	: DF
END SEARCH	: OFF
LOOP /INTVAL REC:	OFF
LOOP REC TIME	: 0SEC

Item	Content
ASSIGN SW 1	Assigns the function to ASSIGN 1 (push-type) switch.
ASSIGN SW 2	Assigns the function to ASSIGN 2 (slide-type) switch.

(Continued)

- 3** Turn the MENU knob to move the → mark to either ASSIGN SW 1 or 2 to which you want to assign the function, and push the MENU knob.

The ASS <1> or <2> SEL window corresponding to the selected switch appears.

ASS <1> SEL window

Scrolls down on the window.

```
ASS <1> SEL ESC
→00.OFF
01.F.MIC MONO/STEREO
02.LOOP REC ON/OFF
03.TEST OUT CHARACTER
04.MARKER ON/OFF
05.EZ FOCUS
06.RE-TAKE
07.ATW
08.RETURN VIDEO
09.LENS RET
```

ASS <2> SEL window

```
ASS <2> SEL ESC
→00.OFF
01.F.MIC MONO/STEREO
02.LOOP REC ON/OFF
03.TEST OUT CHARACTER
04.MARKER ON/OFF
05.ZEBRA ON/OFF
```

Functions to be assigned to the ASSIGN 1 (push-type) switch

Function	Content
OFF	Disables the switch.
F.MIC MONO/STEREO	Assigns the monaural/stereo switch function when the stereo microphone is connected to the MIC IN connector.
LOOP REC ON/OFF	Assigns the Loop Rec mode ON or OFF function. ^{a)}
TEST OUT CHARACTER	Assigns the function to switch whether or not the characters are mixed to the video signal to be output from the TEST OUT connector.
MARKER ON/OFF	Assigns the ON/OFF function to display all markers. ^{b)}
EZ FOCUS	Assigns the ON/OFF function of the EZ FOCUS ^{c)} function.
RE-TAKE	Assigns the RE-TAKE function to the switch.
ATW	Assigns the ON/OFF function of auto-tracing white balance.
RETURN VIDEO	Assigns the ON/OFF function to display the image of the return video signal on the viewfinder to the switch. ^{d)}
LENS RET	Assigns the same function as that of the RET switch on the lens to the switch.
REC SWITCH	Assigns the VTR S/S (start/stop) function to the switch.
TURBO SWITCH	Assigns the turbo gain function to the switch.
ZEBRA ON/OFF	Assigns the zebra pattern display function to the switch.

(Continued)

- a) When an HKDW-703 is not installed, even though you can assign this function to the ASSIGN 1 switch on the ASS <1> SEL window, the ASSIGN 1 switch does not work.
- b) Even when MARKER is set to OFF on the MARKER page of the USER menu, the ASSIGN 1 switch allows you to display or not to display all markers.
- c) EZ FOCUS

When EZ FOCUS is set to ON, the iris stays open and the video level is automatically adjusted to the proper level by the electronic shutter when an excessive amount of light passes through the lens. The depth of field is shallow because the iris stays open, and it is easy to check whether the object is in clear focus.

Pressing the switch again sets the EZ FOCUS function to OFF. This function automatically returns to OFF about 10 seconds after being set to ON.

- d) Even if RETURN VIDEO is set to OFF on the GENLOCK page of the MAINTENANCE menu, you can use this switch to display the image of the return video signal on the viewfinder.

Functions to be assigned to the ASSIGN 2 (slide-type) switch

Function	Content
OFF	Disables the switch.
F.MIC MONO/STEREO	Assigns the monaural/stereo switch function when the stereo microphone is connected to the MIC IN connector.
LOOP REC ON/OFF	Assigns the Loop Rec mode ON or OFF function.
TEST OUT CHARACTER	Assigns the function to switch whether or not the characters are mixed to the video signal to be output from the TEST OUT connector.

Function	Content
MARKER ON/OFF	Assigns the ON/OFF function to display all markers. ^{a)}
ZEBRA ON/OFF	Assigns the zebra pattern display function to the switch.

- a) Even when MARKER is set to OFF on the MARKER page of the USER menu, the ASSIGN 2 switch allows you to display or not to display all markers.

Note

For functions that are assigned to the ASSIGN 2 switch, you cannot change those settings using other menus. The function assigned to ASSIGN 2 switch takes precedence over the menu setting.

- 4** Turn the MENU knob to move the → mark to the item you want to set, and push the MENU knob.

To return to the FUNCTION 1 page

Turn the MENU knob to move the → mark to ESC on the right top of the window and push the MENU knob.

Or push the CANCEL/PRST / ESCAPE switch down to the ESCAPE side.

To end menu operations

Set the MENU ON/OFF switch to OFF. Or close the cover.

4-8-6 Setting the Date/Time of the Internal Clock

You can set or change the date and time of the internal clock. The date and time set are stored in the time code.

- 1 Follow the procedure of steps 1 to 3 described in “4-7-9 Confirming the Image of the Return Video Signal on the Viewfinder” on page 4-94 to display the TIME/DATE page of the DIAGNOSIS menu.

4

02OTIME/DATE		
→ ADJUST	:	EXEC
HOUR	:	12
MIN	:	55
SEC	:	58
YEAR	:	00
MONTH	:	07
DAY	:	31

The → mark is placed at ADJUST.

- 2 Push the MENU knob.

The TIME ADJUST setting window appears.

TIME ADJUST		
HOUR	:	12
MIN	:	55
SEC	:	58
YEAR	:	00
MONTH	:	07
DAY	:	31
OK		

Item	Contents
HOUR	Sets the hour value.
MIN	Sets the minutes value.
SEC	Sets the seconds value.
YEAR	Sets the year.
MONTH	Sets the month.
DAY	Sets the day.

- 3** Turn the MENU knob to move the → mark to the item you want to set, and push the MENU knob.

The → mark at the left of the selected item changes to a ● mark and the ● mark at the left of the setting changes to a ? mark.

- 4** Turn the MENU knob to display the desired value, and push the MENU knob.

The ● mark at the left of the selected item changes to a → mark and the ? mark at the left of the setting changes to a ● mark.

- 5** To continue the remaining settings, repeat steps 3 and 4.

- 6** When you finish the settings, turn the MENU knob to move the → mark to OK, then push the MENU knob.

The internal clock is set with the date and time set in steps 3 to 5. The TIME/DATE page of the DIAGNOSIS menu appears again. The time set on the TIME ADJUST setting window is displayed.

To cancel the setting

Before performing the operation in step 6, move the → mark to ESC on the right top of the window and push the MENU knob.

Or push the CANCEL/PRST / ESCAPE switch down to the ESCAPE side.

All settings or changes are discarded and the TIME/DATE page of the DIAGNOSIS menu appears.

4 4-8-7 Selecting the Lens File

The LENS FILE page of the USER menu allows you to change the lens file according to the lens in use.

- 1 Set the MENU ON/OFF switch to ON.

The page that was on the screen when the last menu operation ended appears on the viewfinder screen.

- 2 Turn the MENU knob until the LENS FILE page appears, and push the MENU knob.

The LENS FILE page appears.

The name and the f-stop (iris setting) of the lens currently selected appears.

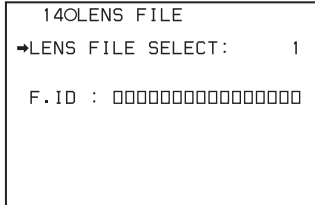

```
14OLENS FILE
→LENS FILE SELECT:      1
F.ID : 0000000000000000
```

-
- 3** Turn the MENU knob to move the → mark to LENS FILE SELECT, and push the MENU knob.

The → mark at the left of the selected item changes to a ● mark and the ● mark at the left of the setting changes to a ? mark.

- 4** Turn the MENU knob until the lens file No. in use appears, and push the MENU knob.

The ● mark changes to the → mark and the ? mark at the left of the lens No. changes to a ● mark.

The selected lens file is loaded.

- 5** To end menu operations, set the MENU ON/OFF switch to OFF, or close the cover.

4-9 Saving/Loading User Menu Data to/from Memory Stick

The camcorder is equipped with a memory stick drive, which enables you to save the user file, scene files, lens files, reference files and ALL files.

This section explains how to handle the Memory Stick and save/load a user file to/from the Memory Stick. You can use a Memory Stick with memory capacity of up to 64 MB with the camcorder.

For detailed information on the scene file, see “4-11 Using the Scene Files” on page 4-135.

For detailed information on the lens files, reference files and ALL files, refer to the Maintenance Manual.

4-9-1 Handling the Memory Stick

The Memory Stick can be inserted or removed from the camcorder with the power turned on or off.

Inserting the Memory Stick

- 1 Push the MEMORY STICK OPEN button.

The cover of the Memory Stick compartment opens.

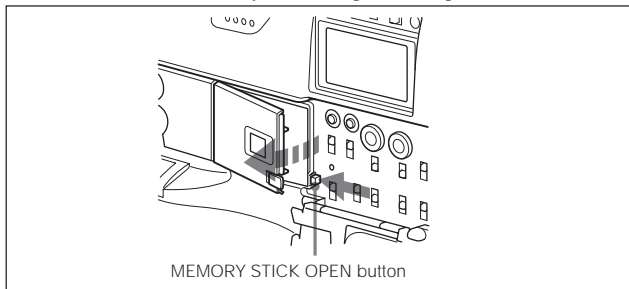

- 2** Hold the Memory Stick with the notch facing downward and the arrow facing toward you, and insert the Memory Stick into the memory stick insertion slot until it clicks into place. Then, close the cover.

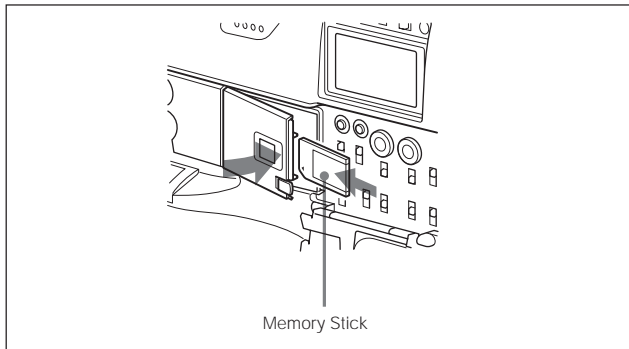

Inserting the Memory Stick.

Note

If it does not fit into the slot properly or if there is some resistance when you insert it, the Memory Stick may be turned around or upside down. Do not force the Memory Stick into the slot. Confirm the direction of the notch and arrow on the Memory Stick before inserting the Memory Stick, and then try inserting it again.

Removing the Memory Stick

Open the cover of the Memory Stick compartment.

Push the eject button after confirming that the ACCESS indicator (access indicator) is not lit. The Memory Stick pops out.

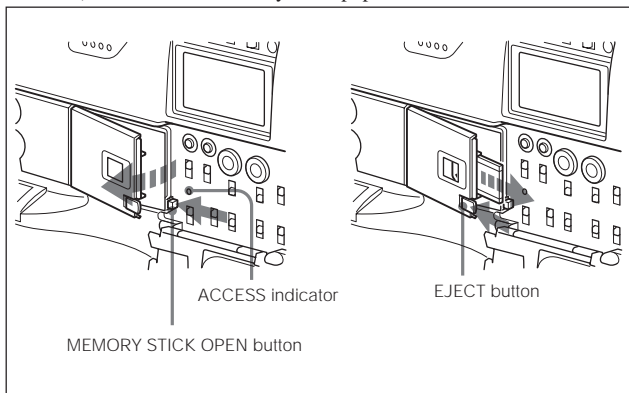

Removing the Memory Stick

Note

Do not remove the Memory Stick while the ACCESS indicator is lit. The camcorder is reading or writing data on the Memory Stick.

Protecting saved data

To prevent accidental erasure of important setup data, use the write protect switch on the Memory Stick.

Slide the switch right to the write protect position. It is now impossible to write or delete data on the Memory Stick.

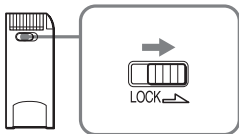

Write protect switch on the Memory Stick

Notes on using and storing the Memory Stick

- Avoid touching the connector of the Memory Stick or contacting it with a metal object.
 - When attaching a label to the Memory Stick, use only the label supplied for the Memory Stick.
 - Do not drop, bend, or submit the Memory Stick to external shock.
 - Do not disassemble or modify the Memory Stick.
 - Avoid getting liquids on the Memory Stick.
 - Avoid using or storing the Memory Stick in a location subject to:
 - extremely high temperature such as the hot inside of a car or the outdoors exposed to a burning sun, or a place near a heater
 - direct sunlight
 - high humidity
 - excessive dust
 - When storing and carrying the Memory Stick, keep it in its original case to ensure protection of important data.
 - When carrying the camcorder with the Memory Stick inserted, close the cover.
 - Avoid removing the Memory Stick from the insertion slot while the ACCESS indicator is lit.
 - Do not format the Memory Stick using a PC.
- The MEMORY STICK page of the FILE menu allows you to format the Memory Stick.

For detailed information on how to format, refer to the maintenance manual.

4-9-2 Saving/Loading User Menu Data to/from Memory Stick

The section explains the operations to save data to and load it from the Memory Stick. Operations are done from the USER FILE page of the USER menu.

You can recreate suitable setup condition rapidly using data in the Memory Stick.

4 Saving data to the Memory Stick

You can save up to 100 user files in the Memory Stick.

Insert the Memory Stick, then follow the procedure below.

- 1 Set the MENU ON/OFF switch to ON.

The page that was on the screen when the last menu operation ended appears on the viewfinder screen.

- 2 Turn the MENU knob until the USER FILE page appears, and push the MENU knob.

```
130USER FILE
→USER FILE LOAD  :D EXEC
USER FILE SAVE   : EXEC
F.ID : 0000000000000000
USER PRESET      : EXEC
```

If you want to set a file ID for the data to be saved, set the file ID before going to the step 3.

For detailed information on setting the file ID, see “Setting the file ID” on page 4-130.

- 3 Turn the MENU knob to move the → mark to USER FILE SAVE, and push the MENU knob.

The P00 USER SAVE window appears.

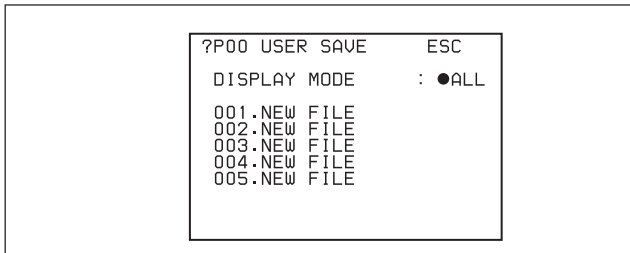

The ? mark is displayed to the left of P00 at the top left of the window. In this case, you can change the page. You can use up to 20 pages, from P00 to P19, to save user files in the Memory Stick. Each page can hold up to 5 files.

(Continued)

- 4** Turn the MENU knob until the page which contains the desired file number appears, and push the MENU knob.

When P00 page is selected

By pushing the MENU knob when the ? mark is placed at the left of P00, the → mark moves to DISPLAY MODE.

```
P00 USER SAVE      ESC
→DISPLAY MODE      : ●ALL
001.NEW FILE
002.NEW FILE
003.NEW FILE
004.NEW FILE
005.NEW FILE
```

- 5** Turn the MENU knob to move the → mark to the desired file No., and push the MENU knob.

The file number indicated as NEW FILE is vacant.

The file number where data already has been saved, the file name is displayed.

```
P00 USER SAVE      ESC
MEMORY STICK ACCESS
DISPLAY MODE       : ●ALL
→001.NEW FILE
002.NEW FILE
003.NEW FILE
004.NEW FILE
005.NEW FILE
```

The message “MEMORY STICK ACCESS ” appears and the ACCESS indicator is on.

The setting data is saved in the Memory Stick as the user file.

When the saving is completed, the message “COMPLETE!” appears and the ACCESS indicator also goes off.

If no Memory Stick has been inserted, the message “NO MEMORY STICK” will appear. Insert a Memory Stick.

When you select the file number where the data has been saved

The message “OVERWRITE OK YES NO” appears. In this case, the → mark is placed at the left of NO, and NO blinks.

To stop overwriting, press the MENU knob.

To overwrite, move the → mark to YES (YES blinks) and push the MENU knob.

You can select the contents of the user file to be displayed on the page.

For details, see “Selecting the display contents” on page 4-132.

To cancel the saving and return to the USER FILE page

Before pushing the MENU knob in step 5, move the → mark to ESC at the right top of the window by turning the MENU knob and push the MENU knob.

The USER FILE page appears again and the → mark is placed at the USER FILE SAVE item.

- 6** To end menu operations, set the MENU ON/OFF switch to OFF, or close the cover.

USER menu settings to be saved in the Memory Stick

Settings for items on all pages of the USER menu are saved in the Memory Stick as a user file. However, you can select the settings which are not to be saved in the Memory Stick.

For details, see the Maintenance Manual.

If data cannot be saved

If one of the following error messages appears when you push the MENU knob in step 5 of the procedure in the previous section (page 4-124), then the data was not saved.

Data save error messages

Error message	Reason	Action
NO MEMORY STICK (flashing)	No Memory Stick is inserted.	Insert or reinsert the Memory Stick.
MEMORY STICK LOCKED	The write protect switch on the Memory Stick is set to the write protect position.	Set the write protect switch to the write enable position.
MEMORY STICK ERROR (flashing)	Circuit or Memory Stick fault.	Check the circuitry, or replace the Memory Stick .

Loading saved data from a Memory Stick

Follow the procedure below.

- 1 Set the MENU ON/OFF switch to ON.

The page that was on the screen when the last menu operation ended appears on the viewfinder screen.

- 2 Turn the MENU knob until the USER FILE page appears, and push the MENU knob.

- 3** Turn the MENU knob to move the → mark to USER FILE LOAD, and push the MENU knob.

The P00 USER LOAD window appears.

?P00 USER LOAD	ESC
DISPLAY MODE	: ALL
001.USER1	00/08/01
002.USER2	00/08/10
003.NO FILE	
004.USER4	00/09/20
005.USER5	00/10/03

4

- 4** Turn the MENU knob until the page which contains the desired file No. appears, and push the MENU knob.

When P00 page is selected

By pushing the MENU knob when the ? mark is placed at the left of P00, the → mark moves to DISPLAY MODE.

P00 USER LOAD	ESC
→DISPLAY MODE	: ALL
001.USER1	00/08/01
002.USER2	00/08/10
003.NO FILE	
004.USER4	00/09/20
005.USER5	00/10/03

(Continued)

- 5** Turn the MENU knob to move the → mark to the desired file number to be loaded, and push the MENU knob.

P00.USER LOAD	ESC
MEMORY STICK ACCESS	
DISPLAY MODE	: ALL
001.USER1	00/08/01
→002.USER2	00/08/10
003.NO FILE	
004.USER4	00/09/20
005.USER5	00/10/03

The message “MEMORY STICK ACCESS ” appears and the ACCESS indicator is on.

When the loading is completed, the message “COMPLETE!” appears and the ACCESS indicator also goes off.

The setting data is loaded in the camcorder from the Memory Stick.

Note

The data loaded from the Memory Stick overwrite the data saved in the camcorder.

To cancel the loading and return to the USER FILE page

Before pushing the MENU knob in step 5, move the → mark to ESC at the right top of the window by turning the MENU knob and push the MENU knob.

The USER FILE page appears again and the → mark is placed at the USER FILE LOAD item.

- 6** To end menu operations, set the MENU ON/OFF switch to OFF, or close the cover.

If data cannot be loaded

If one of the following error messages appears when you push the MENU knob in step 5 (on page 4-128), then the data was not loaded.

Data load error messages

Error message	Reason	Action
NO MEMORY STICK (flashing)	No Memory Stick is inserted.	Insert or reinsert the Memory Stick.
MEMORY STICK ERROR (flashing)	Circuit or Memory Stick fault.	Recheck, and consult a Sony representative.
FILE ERROR (flashing)	The Memory Stick contains data that cannot be loaded with this camcorder.	Do not try to load data saved with another camcorder.

Setting the File ID

Before data is saved to a Memory Stick, it is useful to set a file ID for the Memory Stick to identify it.

When data is saved to a Memory Stick, a file ID is saved to the Memory Stick together with the data.

- 1 Turn the MENU knob to move the → mark to F. ID on the USER FILE page.

4

```
130USER FILE
USER FILE LOAD : EXEC
USER FILE SAVE : EXEC
→F.ID : □□□□□□□□□□□□□□□□
USER PRESET   : EXEC
```

- 2 Push the MENU knob.

The F. ID window where you can set the file ID appears.

```
F.ID          ESC
█ ↓          █ END
ABCDEF GHIJ KLMNOP QRSTUVW
XYZ 0123456789 !#$%&()*+
,-./:;<=>?@
RET INS DEL
```

-
- 3** Follow the procedure of steps 4 and 5 described in “4-7-7 Setting the Shot ID” on page 4-84 to enter the file ID.

Note

Execute the file ID before saving data in the Memory Stick. Otherwise, the file ID is not saved with the other data.

- 4** When you finish entering the file ID, turn the MENU knob to move the ↓ mark to END, then push the MENU knob.

The USER FILE page appears.

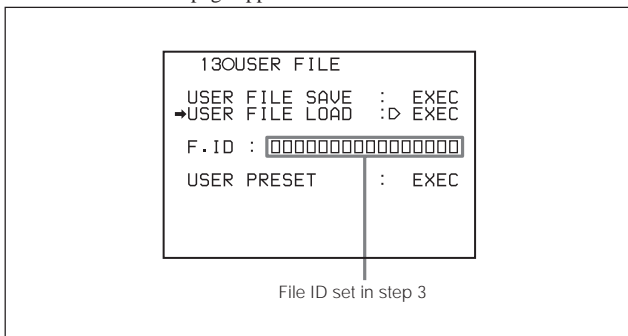

Perform operations from step 3 in “Saving data to the Memory Stick” on page 4-122.

This file ID is stored in the Memory Stick with data.

Selecting the display contents

You can select the contents of the file to be displayed on the USER SAVE window and USER LOAD window.

- 1 Turn the MENU knob to move the → mark to DISPLAY MODE, and push the MENU knob.
- 2 Turn the MENU knob until the desired type of the display contents appears, and then push the MENU knob.

```
P00 USER SAVE      ESC
→DISPLAY MODE      :●F.ID

001.USER1
002.USER2
003.NO FILE
004.USER4
005.USER5
```

Item	Contents
ALL	File ID (10 characters) and store date (year/month/date)
F.ID	File ID (16 characters)
DATE	Store date (year/month/date/hours/minutes/seconds)

4-10 Resetting USER Menu Settings to the Standard Settings

You can clear all current settings for items of the USER menu and return settings to the standard settings (factory settings or preset settings). When you first use the camcorder, the standard settings are the same as the factory settings. You can change them. The changed data are treated as preset settings.

For detailed information on how to change the factory settings, see the Maintenance Manual.

Follow the procedure below to reset all settings to the standard setting.

- 1 Set the MENU ON/OFF switch to ON.

The page that was on the screen when the last menu operation ended appears on the viewfinder screen.

- 2 Turn the MENU knob until the USER FILE page appears, and then push the MENU knob.

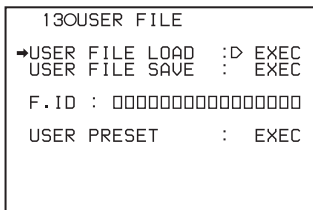

```
130USER FILE
→USER FILE LOAD  :▷ EXEC
  USER FILE SAVE  :  EXEC
F.ID  : □□□□□□□□□□□□□□□□
USER PRESET      :  EXEC
```

(Continued)

- 3** Turn the MENU knob to move the → mark to USER PRESET, and push the MENU knob.

```
130USER FILE
PRESET DATA OK? YES→NO
USER FILE LOAD   : EXEC
USER FILE SAVE   : EXEC

F.ID : 00000000000000000000

→USER PRESET    :▷ EXEC
```

The message “PRESET OK? YES NO ” appears. In this case, the → mark is placed at the left of NO and NO blinks.

- 4** Turn the MENU knob to move the → mark to YES (YES blinks), and push the MENU knob.

Settings for all items in the USER menu are reset to the standard settings.

4-11 Using the Scene Files

You can save various detail-adjusted data customized to certain shooting scenes as a scene file. Loading the scene file, you can quickly recreate setup conditions suitable for the scene.

You can store up to five scene files in the camcorder memory and up to 100 scene files in a Memory Stick.

Beyond that, you can load data stored in the Memory Stick into the camcorder memory.

Data that can be stored in the scene file

You can store the following data in a scene file:

- Adjusted values using the PAINT menu

For detailed information on the PAINT menu, see “PAINT Menu List” on page A-19.

- Shutter speed settings in the standard mode and ECS mode
- Settings of ND/CC filter knob (when the optional BKDW-701 servo filter unit is equipped)
- White balance data to be stored or loaded depends on settings of the SCENE WHITE DATA on the REFERENCE page of the FILE menu.

For details, see “Data of the white balance to be stored in the scene file” on page 4-140.

4-11-1 Storing Data in the Scene File

Follow the procedure below to store data as the scene file in the camcorder memory or the Memory Stick.

To store the data as the scene file in the Memory Stick, insert the Memory Stick before starting the operation.

- 1** Follow the procedure of steps 1 to 3 described in “4-7-9 Confirming the Image of the Return Video Signal on the Viewfinder” on page 4-94 to display the SCENE FILE page of the FILE menu.

The SCENE FILE page appears.

04OSCENE FILE

01	:	□□□□□□□□□□□□□□□□
02	:	□□□□□□□□□□□□□□□□
03	:	□□□□□□□□□□□□□□□□
04	:	□□□□□□□□□□□□□□□□
05	:	□□□□□□□□□□□□□□□□

□STANDARD

SCENE RECALL	:	EXEC
SCENE STORE	:	EXEC
F.ID	:	

If you want to set a file ID for the data to be stored, set the file ID before going to the step 2.

For detailed information on setting the file ID, see “Setting the file ID” on page 4-144.

- 2** Turn the MENU knob to move the → mark to SCENE STORE, and then push the MENU knob.

04OSCENE FILE

01	:	□□□□□□□□□□□□□□□□
02	:	□□□□□□□□□□□□□□□□
03	:	□□□□□□□□□□□□□□□□
04	:	□□□□□□□□□□□□□□□□
05	:	□□□□□□□□□□□□□□□□

□STANDARD

SCENE RECALL	:	EXEC
→SCENE STORE	:	DEXEC
F.ID	:	

When no Memory Stick has been inserted, the SCENE STORE window appears.

When a Memory Stick has been inserted, the P00 SCENE STORE window appears.

SCENE STORE window (When no Memory Stick has been inserted)

```
SCENE STORE    ESC
→DISPLAY MODE :  ALL
MEM(1) :NEW FILE
MEM(2) :NEW FILE
MEM(3) :NEW FILE
MEM(4) :NEW FILE
MEM(5) :NEW FILE
```

P00 SCENE STORE window (When a Memory Stick has been inserted)

```
?P00 SCENE STORE  ESC
DISPLAY MODE      :  ALL
MEM(1) :NEW FILE
MEM(2) :NEW FILE
MEM(3) :NEW FILE
MEM(4) :NEW FILE
MEM(5) :NEW FILE
```

(Continued)

3 Select the file No.

When no Memory Stick has been inserted:

Turn the MENU knob to move the → mark to the desired file No., and push the MENU knob.



```
SCENE STORE  ESC
DISPLAY MODE  :  ALL
MEM(1) : NEW FILE
MEM(2) : NEW FILE
→MEM(3) : NEW FILE
MEM(4) : NEW FILE
MEM(5) : NEW FILE
```

When the storing is completed, the SCENE FILE page appears again.

When you select the file number where the data has been stored:

The message “OVERWRITE OK YES NO” appears. In this case, the → mark is placed at the left of NO, and NO blinks.

To stop overwriting, press the MENU knob.

To overwrite, move the → mark to YES (YES blinks) and push the MENU knob.

When a Memory Stick has been inserted:

The ? mark is displayed to the left of P00 at the top left of the window. In this case, you can change the page. You can use up to 20 pages, from P01 to P20, to store scene files in the Memory Stick.

Each page can hold up to 5 files.

- ① Turn the MENU knob until the page which contains the desired file No. appears, and then push the MENU knob.

```

P01 SCENE STORE   ESC
→DISPLAY MODE    : ●ALL

001.SCENE10 00/08/01
002.NEW FILE
003.NEW FILE
004.NEW FILE
005.NEW FILE

***.5FILE SAVE ← MEM1-5

```

- ② Turn the MENU knob to move the → mark to the desired file No., and then push the MENU knob.

```

P01 SCENE STORE   ESC
MEMORY STICK ACCESS
DISPLAY MODE     : ALL

001.SCENE1      00/08/01
002.NEW FILE
003.NEW FILE
→004.NEW FILE
005.NEW FILE

***.5FILE SAVE ← MEM1-5

```

The message “MEMORY STICK ACCESS ” appears.

When the storing is completed, the message “COMPLETE!” appears, and the ACCESS indicator also goes off.

To cancel the storing and return to the SCENE FILE page:

Before pushing the MENU knob in step ②, move the → mark to ESC at the right top of the window by turning the MENU knob and push the MENU knob.

The SCENE FILE page appears again.

(Continued)

When you select the file No. where the data has been saved:

The message “OVERWRITE OK YES NO” appears. In this case, the → mark is placed at the left of NO, and NO blinks. To stop overwriting, press the MENU knob. Repeat step ②. To overwrite, move the → mark to YES (YES blinks) and push the MENU knob.

You can select the contents of the user file to be displayed on the page.

For details, see “Selecting the display contents” on page 4-144.

- 4** To end menu operations, set the MENU ON/OFF switch to OFF, or close the cover.

To return to the SCENE FILE page

After the message “COMPLETE!” is displayed in step 3, move the → mark to ESC at the right top of the window by turning the MENU knob and push the MENU knob.

The SCENE FILE page appears again.

Data of the white balance to be stored in the scene file

Data of the white balance to be stored in the scene file depends on the setting of SCENE WHITE DATA on the REFERENCE page of the FILE menu.

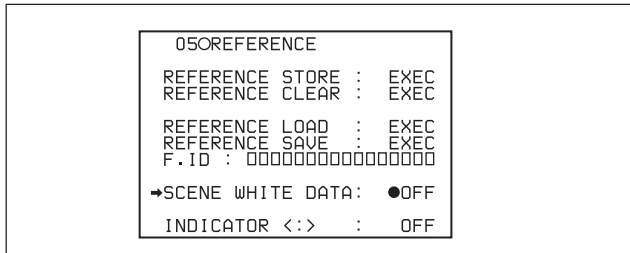

When SCENE WHITE DATA is set to ON:

Data of the white balance selected when you store the scene file is stored. For example, when the WHITE BAL switch is set to A, the adjusted values in memory A are stored in the scene file, when the WHITE BAL switch is set to PRST, the preset value is stored.

When SCENE WHITE DATA is set to OFF:

Data of the white balance is not stored in the scene file.

Saving scene files stored in the camcorder memory to the Memory Stick

You can save five scene files stored in the camcorder to the Memory Stick at once.

Follow the procedure below.

- 1 Turn the MENU knob until the desired SCENE STORE page appears, and then push the MENU knob.

```

P01 SCENE STORE   ESC
→DISPLAY MODE    : ●ALL
001.SCENE1       00/08/01
002.SCENE2       00/08/10
003.NO FILE
004.SCENE4       00/09/20
005.SCENE5       00/10/03
***.5FILE SAVE ← MEM1-5
  
```

(Continued)

- 2** Turn the MENU knob to move the → mark to 5FILE SAVE ← MEM 1-5, and then push the MENU knob.

```
P01 SCENE STORE      ESC
MEMORY STICK ACCESS
DISPLAY MODE        : ALL

001.SCENE1          00/08/01
002.SCENE2          00/08/10
003.NO FILE
004.SCENE4          00/09/20
005.SCENES         00/10/03

→***.5FILE SAVE ← MEM1-5
```

The message “MEMORY STICK ACCESS ” appears.

When the storing is completed, the message “COMPLETE!” appears and the ACCESS indicator goes off.

To cancel the storing

Before pushing the MENU knob in step 2, move the → mark to ESC at the right top of the window by turning the MENU knob and push the MENU knob.

The SCENE STORE page appears again.

- 3** To end menu operations, set the MENU ON/OFF switch to OFF, or close the cover.

Note

If files have been stored in the page selected in step 1, those files are replaced with files loaded from the camcorder memory. For example, files from 001 to 005 are replaced in the page selected in step 1.

Setting the file ID

Before the file is saved as a scene file, it is useful to set a file ID to identify it.

When a file is stored in the camcorder memory or in a Memory Stick, a file ID is stored in the Memory Stick together with the file.

- 1 Turn the MENU knob to move the → mark to F. ID on the SCENE FILE page.

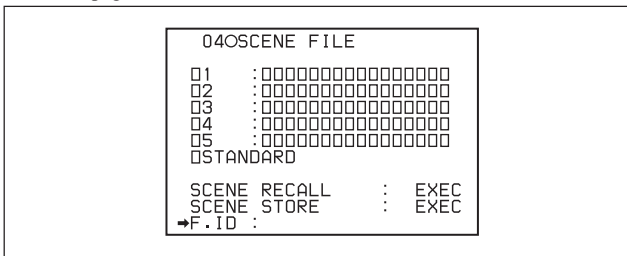

- 2 Push the MENU knob.

The F. ID window where you can set the file ID appears.

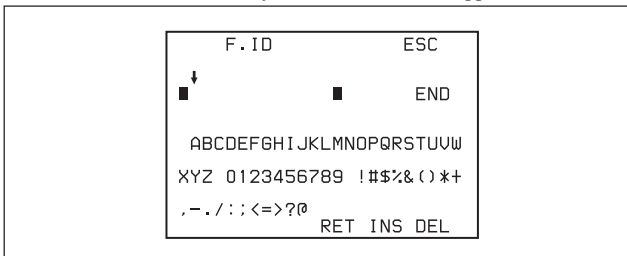

(Continued)

-
- 3** Follow the procedure of steps 4 and 5 described in “4-7-7 Setting the Shot ID” on page 4-84 to enter the file ID.

Note

Execute the file ID before storing the scene file in the Memory Stick or the camcorder memory. Otherwise, the file ID is not stored with the other data.

4

- 4** When you finish entering the file ID, turn the MENU knob to move the ↓ mark to END, and then push the MENU knob.

The SCENE FILE page appears.

```
040SCENE FILE
□1 :
□2 :
□3 :
□4 :
□5 :
□STANDARD
SCENE RECALL : EXEC
SCENE STORE : EXEC
→F.ID : AAAAAAAAAAAAAAAAAA
```

Perform operations from step 2 in “4-11-1 Storing Data in the Scene File ” on page 4-135.

This file ID is saved in the Memory Stick with data.

Selecting the display contents

You can select the contents of the file to be displayed on the SCENE STORE window and SCENE RECALL window.

For detailed information on how to select the display contents, see “Selecting the display contents” on page 4-132.

4-11-2 Loading Scene Files

Follow the procedure below.

- 1 Follow the instructions in steps 1 to 3 described in “4-7-9 Confirming the Image of the Return Video Signal on the Viewfinder” on page 4-94 to display the SCENE FILE page of the FILE menu.

The SCENE FILE page appears.

- 2 Load the scene file.

To load the scene file stored in the camcorder

Turn the MENU knob to move the → mark to the desired file No., and push the MENU knob.

The □ which is displayed at the left of the file No. changes to ■. The camcorder is set up according to the loaded scene file.

040SCENE FILE	
□1	:AAAAAAAAAAAAAA
→■2	:BBBBBBBBBBBBBB
□3	:CCCCCCCCCCCC
□4	:DDDDDDDDDDDD
□5	:NO FILE
□STANDARD	
SCENE RECALL	: EXEC
SCENE STORE	: EXEC
F.ID	:

To cancel the selected scene file

Turn the MENU knob to move the → mark to ■, and push the MENU knob. ■ changes to □.

The camcorder returns to the settings before selecting the scene file.

(Continued)

You can load the scene file stored in the camcorder on the SCENE RECALL window to be displayed in step ① covered in “To load the scene file saved in the Memory Stick.”

To load the scene file saved in the Memory Stick

- ① Turn the MENU knob to move the → mark to SCENE RECALL, and push MENU knob.

4

```
04SCENE FILE
01 :AAAAAAAAAAAAAA
02 :BBBBBBBBBBBBBB
03 :CCCCCCCCCCCCC
04 :DDDDDDDDDDDDDD
05 :NO FILE
0STANDARD
→SCENE RECALL : DEXEC
SCENE STORE : EXEC
F.ID : 0000000000000000
```

The P00 SCENE RECALL window appears. On the P00 page, the scene files saved in the camcorder memory are displayed. You can also recall the scene file stored in the camcorder memory on this page.

```
?P00 SCENE RECALL ESC
DISPLAY MODE : F.ID
MEM(1):AAAAAAAAAAAA
MEM(2):BBBBBBBBBBBBBB
MEM(3):CCCCCCCCCCCCC
MEM(4):DDDDDDDDDDDDDD
MEM(5):NO FILE
```

The ? mark is displayed to the left of P00 at the top left of the window. In this case, you can change the page.

- ② Turn the MENU knob until the page which contains the desired file No. appears, and push MENU knob.
- ③ Turn the MENU knob to move the → mark to the desired file No., and then push the MENU knob.

```
P01 SCENE RECALL ESC
MEMORY STICK ACCESS
DISPLAY MODE : ALL

001 .SCENE1      00/08/01
→002 .SCENE2      00/08/10
003 .NO FILE
004 .SCENE4      00/09/20
005 .SCENE5      00/10/03

***.5FILE LOAD → MEM1-5
```

The message “MEMORY STICK ACCESS ” appears.

When the loading is completed, the message “COMPLETE!” appears. The camcorder is set up according to the loaded scene file.

For the file No. of the file where no data is stored, NO FILE is displayed in the column of that file.

To cancel the loading

Before pushing the MENU knob in step ③, move the → mark to ESC at the right top of the window by turning the MENU knob and push the MENU knob.

The SCENE FILE page appears again.

Loading the scene file stored in the Memory Stick into the camcorder memory

You can load up to five scene files stored in the Memory Stick into the camcorder memory at once.

- 1 Turn the MENU knob until the SCENE RECALL page which contains the desired scene files appears, and push the MENU knob.
- 2 Turn the MENU knob to move the → mark to 5FILE LOAD → MEM 1-5, and then push the MENU knob.

4

```
P01 SCENE RECALL ESC
MEMORYSTICK ACCESS
DISPLAY MODE      : ALL

001.SCENE1       00/08/01
002.SCENE2       00/08/10
003.NO FILE
004.SCENE4       00/09/20
005.SCENES5     00/10/03

→***.5FILE LOAD → MEM1-5
```

The message “MEMORY STICK ACCESS ” appears.

When loading is complete, the message “COMPLETE!” appears and the ACCESS indicator goes off.

Notes

- The scene files loaded from the Memory Stick overwrite data stored in the camcorder memory.
- To load the scene file stored in the camcorder memory under the condition where the Memory Stick has been inserted, return to the P00 SCENE RECALL page and load the desired scene file in the camcorder memory.
- When there is a file where no data is stored (NO FILE is displayed), a file that has the same file number is not overwritten in the camcorder. In the window displayed in step 2, the content of the scene file 3 in the camcorder memory is not replaced.

To cancel the loading

Before pushing the MENU knob in step 2, move the → mark to ESC at the right top of the window by turning the MENU knob and push the MENU knob.

The SCENE FILE page appears again.

4-11-3 Resetting the Settings of the Camcorder to the Standard Settings Saved in the Reference File

You can reset the settings of the camcorder to the settings saved in the reference file (standard settings).

For detailed information on the items subject to the reference file, see the Maintenance Manual.

4

On the SCENE FILE page, turn the MENU knob to move the → mark to STANDARD, then push the MENU knob.

```
04OScene FILE
□1 :AAAAAAAAAAAAAAAA
□2 :BBBBBBBBBBBBBBBB
□3 :CCCCCCCCCCCCCC
□4 :DDDDDDDDDDDDDD
□5 :NO FILE
→■STANDARD

SCENE RECALL : DEXEC
SCENE STORE  : EXEC
F.ID :
```

The □, which is displayed at the left of STANDARD, changes to ■. When ■ changes to □, the settings of the camcorder are reset to the settings stored in the reference file.

If you press the MENU knob again while ■ is lit, operation is canceled, and the camcorder returns to the settings before STANDARD was selected.

4-12 Jumping to a File-Related Menu Page When Inserting a Memory Stick

A Memory Stick enables you to save user files, scene files, lens files, reference files and ALL files. When you insert a Memory Stick with a menu opened, a preset menu page related to the desired file from among five kinds of files is automatically displayed. This allows you to jump to the file page saved and used in the Memory Stick. You can select the file page to be displayed using the MEMORY STICK page of the FILE menu.

- 1 Follow steps 1 to 3 in “4-7-9 Confirming the Image of the Return Video Signal on the Viewfinder” on page 4-94 to display the MEMORY STICK page of the FILE menu.

The MEMORY STICK page appears.

- 2 Turn the MENU knob to move the → mark to MS IN > JUMP TO, then push the MENU knob.

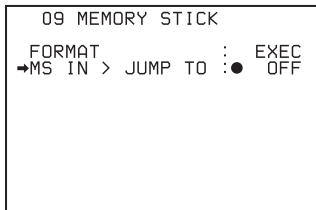

The → mark at the left of MS IN > JUMP TO changes to a ● mark and the ● mark at the left of the setting changes to a ? mark.

(Continued)

- 3** Turn the MENU knob clockwise or counterclockwise until the desired file page appears.

Item	Contents
OFF	Disables this function.
USER	Jumps to the USER FILE page.
ALL	Jumps to the ALL FILE page.
SCENE	Jumps to the SCENE FILE page.
LENS	Jumps to the LENS FILE 1 page.
REFER	Jumps to the REFERENCE page.
USER 1	Jumps to the USER 1 page.

- 4** Press the MENU knob.

The ● mark at the left of MS IN > JUMP TO changes to an → mark and the ? mark at the left of the setting changes to the ● mark.

Notes

In the following cases, the camcorder does not jump to the preset page.

- When the power is turned on after you insert a Memory Stick.
- When OFF is selected for the MS IN > JUMP TO item.
- When a file-related menu page has already been displayed.
 - When a page related to FILE category, such as the USER FILE page is displayed.
 - When one of the following, MEMORY STICK, USER FILE, ALL FILE, SCENE FILE, LENS FILE, REFERENCE FILE or ROM VERSION registered in other categories, is displayed.

5-1 Power Supply

The following power supplies can be used with the camcorder.

- BP-L60A Lithium-ion Battery Pack
- BP-M50/M100 Nickel Metal Hydride Rechargeable Battery Pack
- AC power using the AC-550/550CE or AC-DN2B AC adaptor

5-1-1 Using a Battery Pack

When a BP-L60A Battery Pack is used, the camcorder will operate continuously for about 90 minutes. Before use, charge the battery pack with a BC-L120 Battery Charger. It takes about 2.5 hours to charge one BP-L60A.

For more information, refer to the BC-L120 manual.

When a BP-M50 or M100 Battery Pack is used, the camcorder will operate continuously for about 40 minutes with the BP-M50 and about 120 minutes with the BP-M100. Before use, charge the battery pack with a BC-M50 Battery Charger. It takes about 2 hours to charge one BP-M50 and about 4 hours to charge one BP-M100.

For more information, refer to the BC-M50 manual.

Note on using the battery pack

A warm battery pack may not be able to be fully recharged.

Attaching a battery pack

- 1 Press a battery pack against the back of the camcorder, aligning the side line of a battery pack with the line on the camcorder.

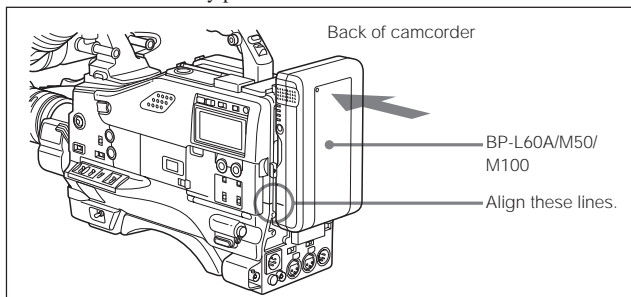

- 2 Slide a battery pack down until its "LOCK" arrow points at the matching line on the camcorder.

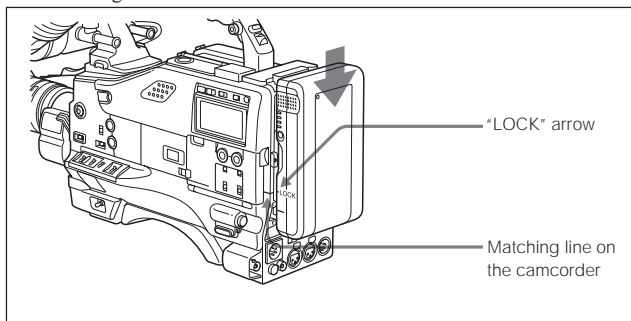

Detaching a battery pack

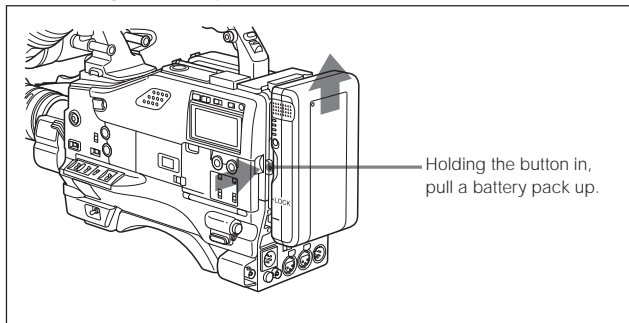

Detaching a battery pack

5-1-2 Avoiding Breaks in Operation Due to Dead Batteries

If you use both an internal battery pack and an external battery connected to the DC IN connector at the same time, you can avoid breaks in operation due to dead batteries.

When an external battery begins to fail and an internal battery pack is also used

Remove the DC output cable from the DC IN connector. The power source will switch to an internal battery pack.

5

When an external battery begins to fail and an internal battery pack is not used

First load the camcorder with a fully charged internal battery pack, then remove the DC output cable of an external battery from the DC IN connector. The power source will switch to the internal battery pack. To use an external battery again, connect a fully charged external battery to the DC IN connector before unloading the internal battery pack. The power source will switch to the external battery.

Continuous operation when operating with only an internal battery pack

First, connect a fully charged external battery to the DC IN connector, then change an internal battery.

Notes

- When an internal battery pack is loaded and an external battery is connected to the DC IN connector, the external battery is always used as the power source.
- There may be some noise on the video signal at the instant the power sources are switched.

5-1-3 Using an AC Adaptor

Using the AC-550/550CE AC adaptor

Connect the camcorder to the AC power supply through the AC-550/550CE AC Adaptor as shown in the following figure, and turn the POWER switch of the AC-550/550CE on.

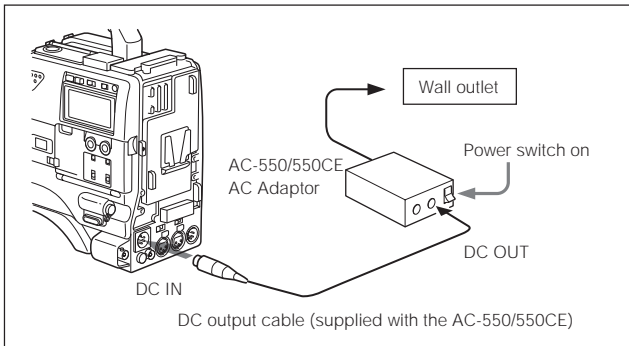

Using an AC Adaptor

Using the AC-DN2B AC adaptor

Mount an AC-DN2B on the camcorder in the same way as a battery pack, then connect to the AC power supply. The AC-DN2B can supply up to 150 W of power.

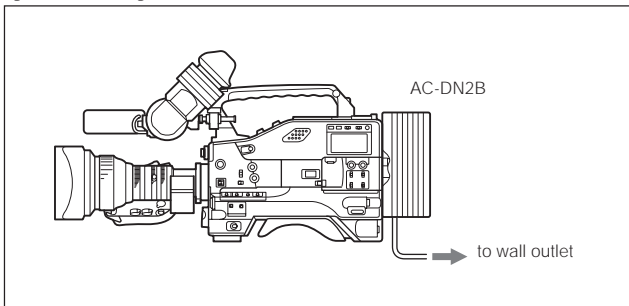

Connecting to an AC power source using the AC-DN2B AC Adaptor

5-1-4 Using the Anton Bauer Ultralight System

By fitting the camcorder with the Anton Bauer Ultralight system, and setting the LIGHT switch to AUTO, you can switch the light on and off automatically as you start and stop VTR operation. This system operates with lights powered by 12 V, with a maximum power consumption of 50 W.

5-2 Adjusting the Viewfinder

For maximum viewing convenience, you can adjust the viewfinder position in the left-right and backward-forward directions.

5-2-1 Adjusting the Viewfinder Position

Adjusting the position to the left or right

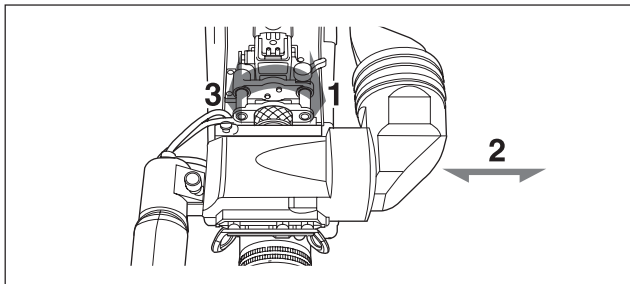

Adjusting the position to the left or right

- 1** Loosen the viewfinder left-right positioning ring.
- 2** Slide the viewfinder to the most convenient position.
- 3** Tighten the viewfinder left-right positioning ring.

To store the camcorder in a carrying case

Always store the camcorder with the viewfinder moved fully in the direction opposite to the barrel and the viewfinder left-right positioning ring tightened.

Adjusting the position backward or forward

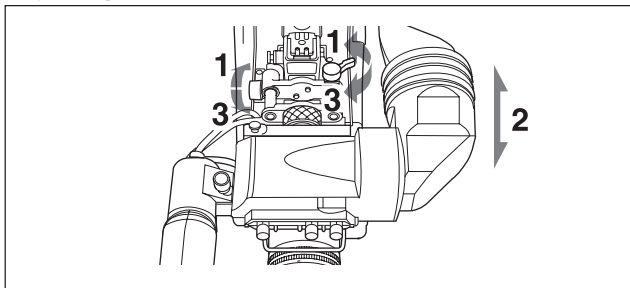

Adjusting the position backward or forward

- 1** Loosen the viewfinder front-rear positioning lever and the LOCK knob.
- 2** Slide the viewfinder longitudinally to the most convenient position.
- 3** Tighten the viewfinder front-rear positioning lever and the LOCK knob.

5-2-2 Adjusting the Viewfinder Focus and Screen

Adjusting the viewfinder focus

Turn the diopter adjustment ring until the viewfinder image is sharpest.

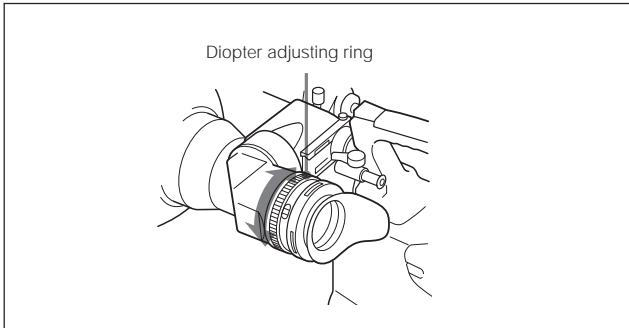

Adjusting the viewfinder focus

Adjusting the viewfinder screen

Adjust the brightness, contrast, and peaking of the viewfinder screen with the control shown below.

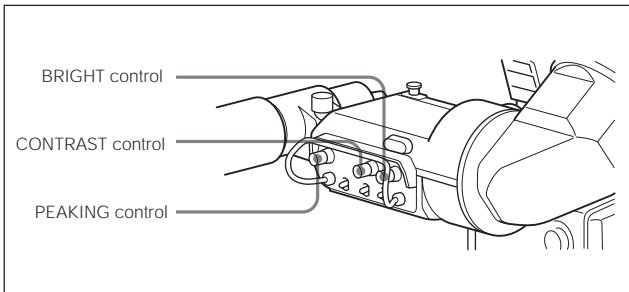

Adjusting the viewfinder screen

5-2-3 Detaching the Viewfinder

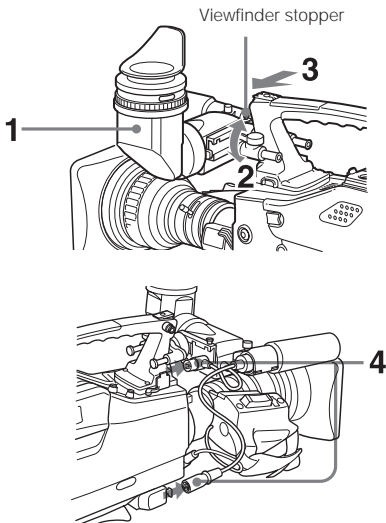

Detaching the viewfinder

- 1** Point the viewfinder barrel up or down.
- 2** Loosen the viewfinder left-right positioning ring.
- 3** Holding the viewfinder stopper up, slide the viewfinder in the direction indicated by the arrow and detach it.

-
- 4** Remove the viewfinder cable and microphone cable from the clamps and disconnect them.

The viewfinder rotation bracket

By fitting a BKW-401 Viewfinder Rotation Bracket (not supplied), you can rotate the viewfinder out of the way so that your right leg does not hit the viewfinder while you are carrying the camcorder.

For more information, refer to the BKW-401 manual.

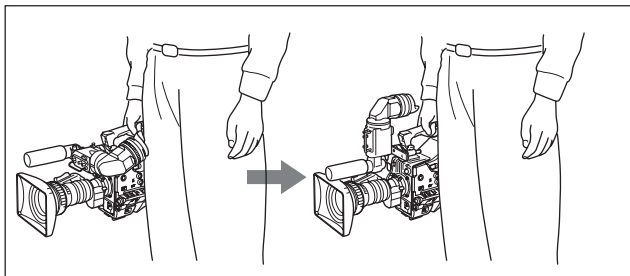

Using the BKW-401 Viewfinder Rotation Bracket

5-2-4 Detaching the Eyepiece

Removing the eyepiece gives a clear view of the screen further away. It is also easy to remove dust from the viewfinder screen and mirror when the eyepiece is detached.

- 1 Turn the eyepiece locking ring fully counterclockwise to line up the red match mark on the locking ring with the red match mark on the viewfinder barrel.

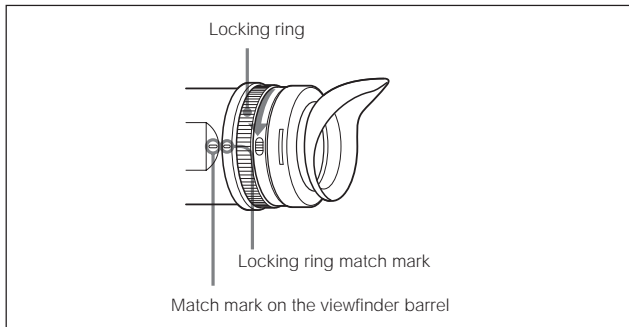

- 2 Detach the eyepiece.

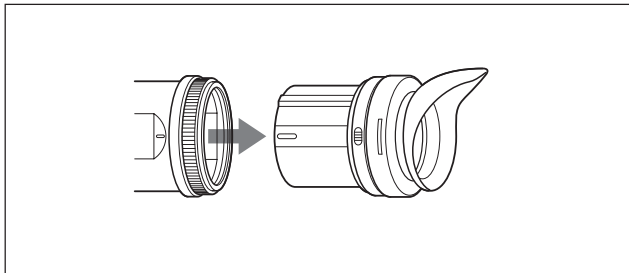

Refitting the eyepiece

- 1 Align the match mark on the eyepiece locking ring with that on the viewfinder barrel.
- 2 Align the match mark on the end of the eyepiece with that of the eyepiece locking ring, then insert the eyepiece into the viewfinder barrel.

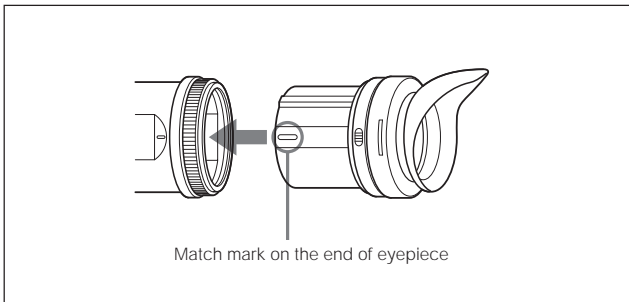

- 3 Turn the eyepiece locking ring clockwise until its “LOCK” indication arrow points to the match mark on the viewfinder barrel.

Note

When the eyecup is worn out, replace it with a new one (service part number 3-723-079-03).

5-3 Mounting the Lens

Follow the procedure below to mount the lens.

For information about using the lens, refer to the lens manual.

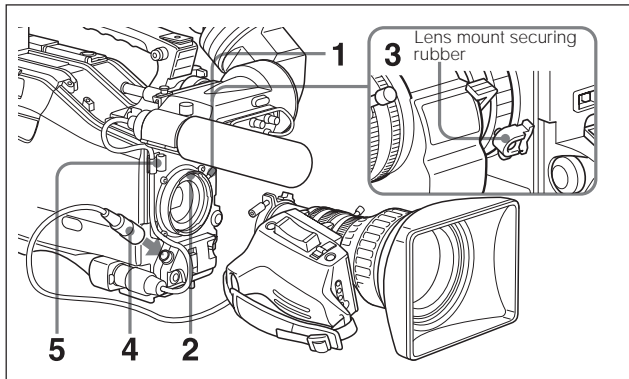

Mounting the lens

- 1 Push the lens locking lever up and remove the lens mount cap from the lens mount.
- 2 Align the center slot in the lens mount with the center pin on the lens, and insert the lens into the mount.
- 3 Holding the lens in place, push the lens locking lever down to mount the lens.

Note

If the lens is not firmly locked, it may come off while the camcorder is being used. This could cause a serious accident. Make sure the lens is firmly locked. It is recommended that the lens mount securing rubber be put on the lens-locking lever as illustrated above.

- 4 Connect the lens cable to the LENS connector.
- 5 Secure the lens cable with the cable clamps.

5-4 Adjusting the Flange Focal Length

If the lens does not stay in focus properly as you zoom from telephoto to wide angle, adjust the flange focal length (the distance from the plane of the lens mounting flange to the imaging plane). Make this adjustment after mounting or changing the lens.

Adjusting the flange focal length

The position of the controls for adjusting the flange focal length vary somewhat from lens to lens. Check the identification of the various controls in the lens manual.

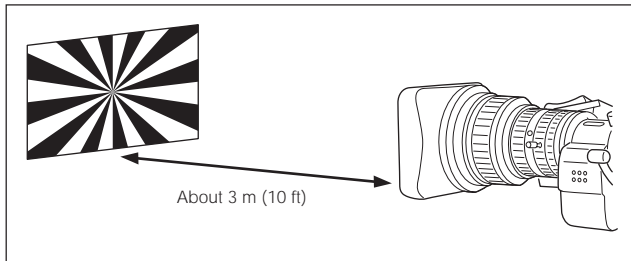

Adjusting the flange focal length

- 1 Set the iris to manual.
- 2 Open the iris. Place the flange focal length adjustment chart about 3 m (10 ft) away from the camera, lit well enough to provide a satisfactory video output level.
- 3 Loosen the fixing screws on the F.f or F.B ring (flange focal length adjustment ring).
- 4 Use manual or power zoom to set the lens to telephoto.

(Continued)

-
- 5** Point the camera at the chart by turning the focus ring and focus on it.
- 6** Set the zoom ring to wide angle.
- 7** Turn the F.f or F.B ring until the chart is in focus, being careful not to disturb the focus ring.
- 8** Repeat steps **4** to **7** until the chart stays in focus all the way from wide angle to telephoto.
- 9** Tighten the F.f or F.B ring fixing screws.

5-5 Audio Input System

5-5-1 Using the Supplied Microphone

The MIC IN connector is the XLR-5-pin (female), so the supplied stereo microphone attached to the camcorder can be used.

Attaching in the supplied microphone in the microphone holder

- 1 Loosen the screw and open the microphone holder clamp.

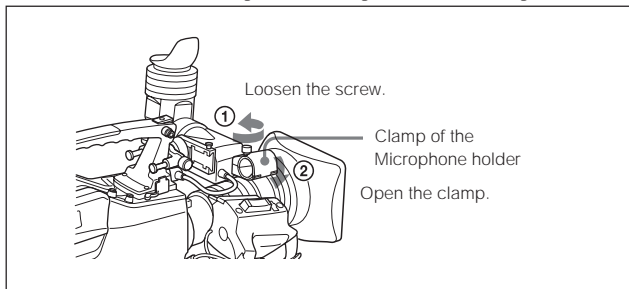

- 2 Place the microphone in the microphone holder.

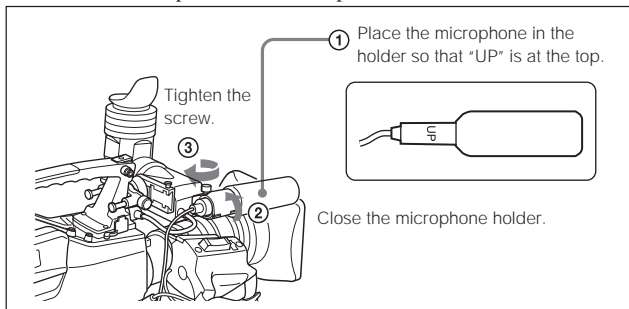

(Continued)

- 3** Plug the microphone cable into the MIC IN connector, then set the AUDIO IN switch for the desired recording channel to FRONT or F.

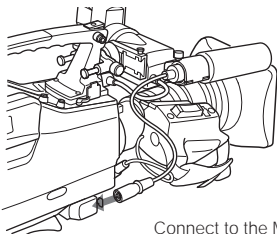

Connect to the MIC IN connector.

5

Recording the stereo sound

You can record either stereo sound or monaural sound using the supplied stereo microphone.

To record the stereo sound:

To record the L and R audio signals of the stereo sound in channels 1 and 2, set both AUDIO IN CH-1 and CH-2 switches to FRONT.

To record the L and R audio signals of the stereo sound in channels 3 and 4, set both AUDIO IN CH-3 and CH-4 switches to F.

Confirm that the front microphone selection function is set to STEREO.

At the factory, the function of FRONT MIC SELECT is assigned to ASSIGN 2 (slide type). Slide the ASSIGN 2 switch to the front (lens side). If you have removed the FRONT MIC SELECT function from the ASSIGN 2 switch, set FRONT MIC SELECT to STEREO on the FUNCTION 1 page of the USER menu or OPERATION menu.

To record the monaural sound:

Set the appropriate AUDIO IN CH-1, CH-2, CH-3 and/or CH-4 switch(es) corresponding to the channel(s) to which you want to record the monaural sound to FRONT or F.

Set the front microphone selection function to MONO.

5-5-2 Using an External Microphone

You can connect up to two external monaural microphones using the AUDIO IN CH-1 and CH-2 connectors. When using a condenser microphone that requires external power (phantom power), set the LINE/MIC/+48 V ON switch to +48 V ON.

If the microphone being used does not require external power (dynamic microphone), set the LINE/MIC/+48 V ON switch to MIC.

Using a detached external microphone

5

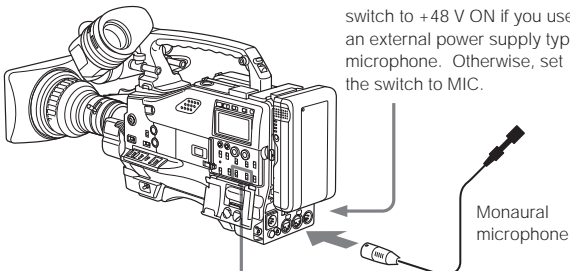

Set the LINE/MIC/+48 V ON switch to +48 V ON if you use an external power supply type microphone. Otherwise, set the switch to MIC.

AUDIO IN switch: At the factory setting, when the audio cable is connected to either the AUDIO IN CH-1 or CH-2 connector, the signal input to the AUDIO IN CH-1 or CH-2 connector is automatically selected as the signal to be recorded. This is true regardless of the AUDIO IN switch setting. (This is called XLR connection automatic detection function.)

When the XLR connection automatic detection function is set to OFF on the VTR MODE 1 page of the MAINTENANCE menu, set the AUDIO IN switch corresponding to the channel to which the microphone is connected to REAR.

Using a detached external microphone

Note

AUDIO IN CH-1 and CH-2 are female XLR (3-pin) connectors. When the microphone cable connector is female, use a converting adaptor.

Using an external microphone attached to the camcorder

You can attach an external microphone to the camcorder by using the CAC-12 Microphone Holder (not supplied). Additionally, by using the CRS-3P Cradle Suspension (not supplied), you can reduce the mechanical vibration noise from the VTR, and can also attach a long microphone. Note, however, that use of the CRS-3P requires a microphone holder (A) (Part No. 3-680-581-01), which is not supplied with the CRS-3P.

The procedure for attaching an external microphone using a CAC-12 and CRS-3P is shown below.

For more information, refer to the manual supplied with the microphone holder or cradle suspension manual.

- 1 Assemble the CRS-3P Cradle Suspension and microphone holder (A) (Part No. 3-680-581-01).

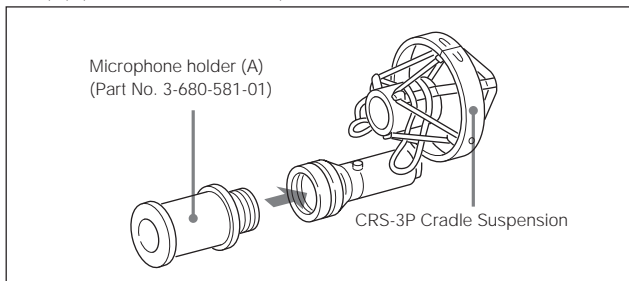

2 Remove the external microphone holder attachment screws.

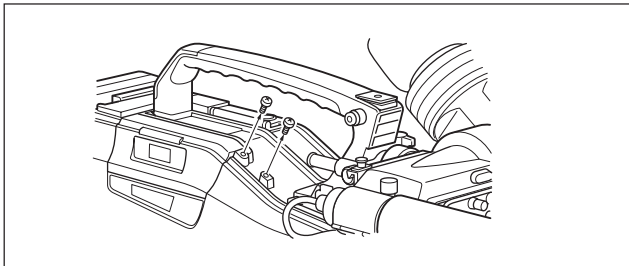

3 Attach the CAC-12 Microphone Holder.

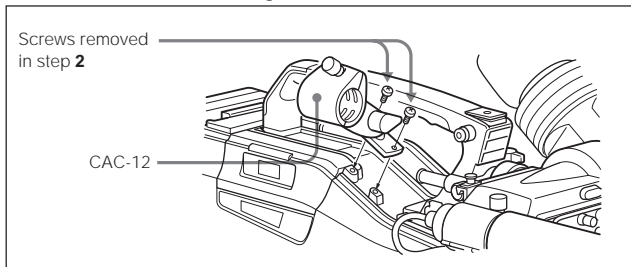

(Continued)

4 Open the CAC-12 and remove the microphone adaptor.

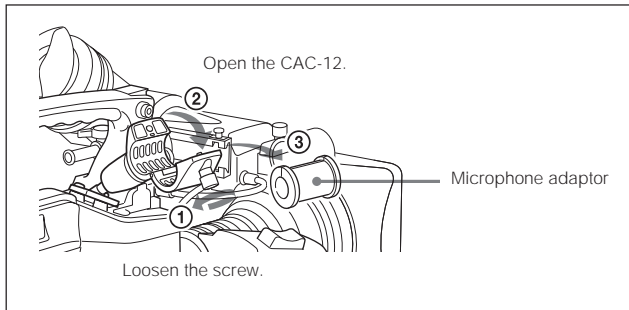

5 Mount the assembly from step 1 in the CAC-12.

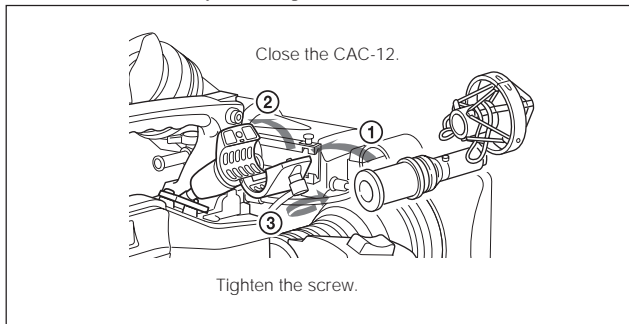

6 Mount the microphone into the cradle suspension.

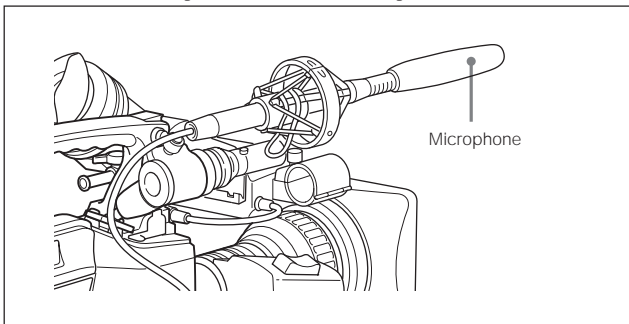

7 Connect the microphone cable to the AUDIO IN CH-1 or AUDIO IN CH-2 connector. Set the corresponding AUDIO IN switch to REAR.

Set the LINE/MIC/+48V ON switch to +48V ON or MIC in accordance with the type of the microphone power supply.

If the microphone you connect to AUDIO IN CH-1 or CH-2 is of the internal batteries type, set the appropriate LINE/MIC/+48V ON switch to MIC.

If the microphone you connect to AUDIO IN CH-1 or CH-2 is of the external power supply type, set the appropriate LINE/MIC/+48V ON switch to +48V ON.

5-5-3 Attaching a UHF Portable Tuner (for a UHF Wireless Microphone System)

To use a Sony UHF wireless microphone system, fit one of the following UHF portable tuners.

- WRR-855A/855B UHF Synthesized Tuner Unit
- WRR-810A/860A/862A/862B UHF Portable Tuner

For each of these UHF portable tuners, use the following attachment procedure. (The WRR-860A is taken as an example below.)

Refer to the UHF portable tuner manual for more information.

5

Fitting the WRR-855A/855B

You can use the WRR-855A/855B UHF Synthesized Tuner Unit simply by inserting it into the slot in the camcorder, and fastening the fixing screws.

- 1 Undo the four fixing screws holding the cover of the slot, and remove the cover.

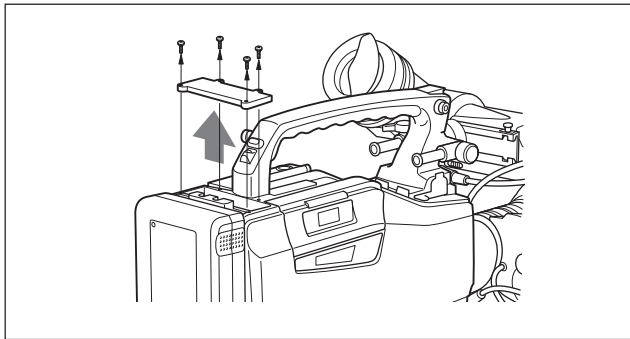

2 Insert the WRR-855A/855B, and fasten the four fixing screws.

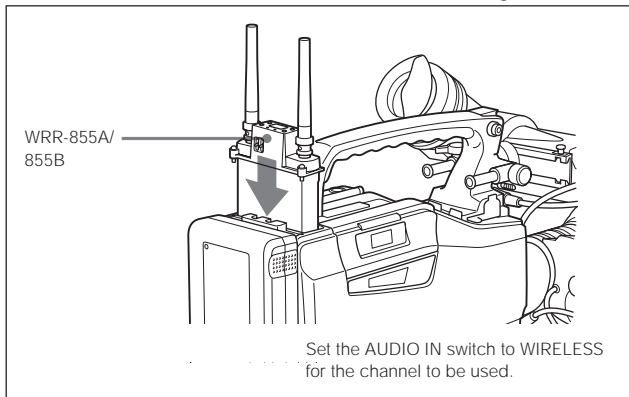

5

For the operation of the WRR-855A/855B, refer to the manual supplied with the WRR-855A/855B.

Note

When the XLR connection automatic detection function is effective, even if the AUDIO IN switch is set to WIRELESS, the signal input to the AUDIO IN CH-1 or CH-2 connector is automatically selected when the audio cable is connected to the AUDIO IN CH-1 or CH-2 connector. In such a case, set REAR XLR AUTO to OFF on the VTR MODE 1 page of the MAINTENANCE menu.

Fitting the WRR-860A (Using a Battery Pack)

- 1** (1) Attach the WRR tuner fitting (not supplied, service part number: A-8278-057-A) to the back of the camcorder.
- ① Pass a screwdriver through the holes and tighten the screws.
 - ② Loosen the adjustment screws.
 - ③ Adjust the tuner fitting position for a BP-L60A/M50/M100 Battery Pack to be attached, and tighten the adjustment screws to fix its position.
 - ④ Attach the BETACAM holder kit supplied with the tuner.
- (2) Attach the battery pack.

For more information about attaching the BP-L60A/M50/M100 Battery Pack, see “5-1-1 Using a Battery Pack” on page 5-1.

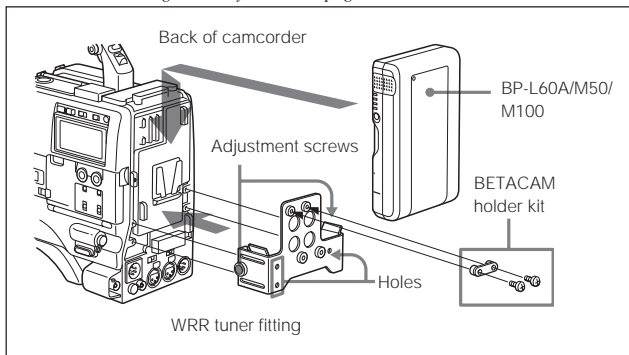

2 Mount the tuner on the WRR tuner fitting.

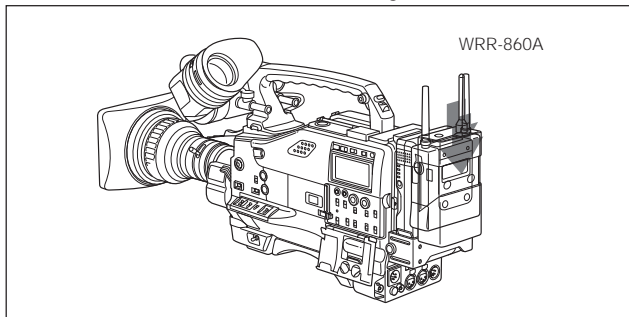

3 Connect the tuner power cord to the DC OUT connector of the camcorder, and the audio output cable to the AUDIO IN CH-1 or CH-2 connector.

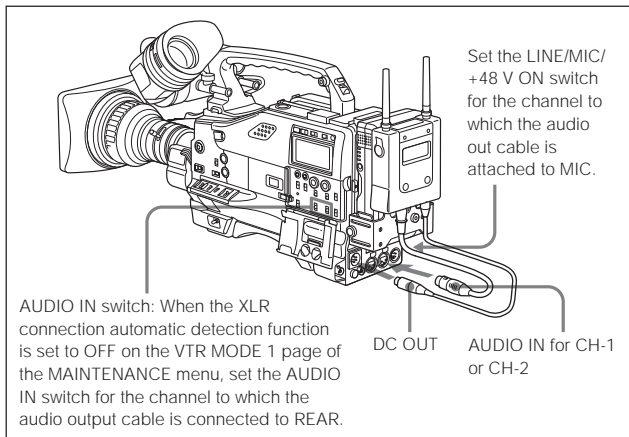

5-5-4 Connecting Line Input Audio Equipment

Connect the audio output connector of the audio equipment that supplies the line input signal to the AUDIO IN CH-1 or CH-2 connector.

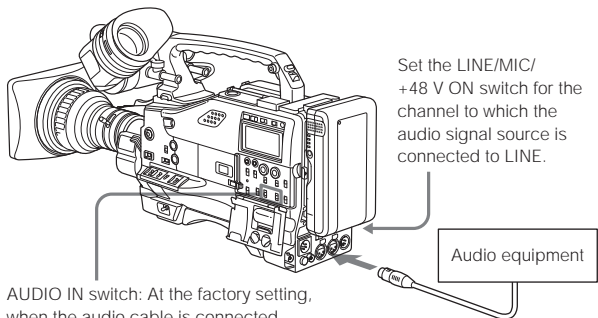

Set the LINE/MIC/
+48 V ON switch for the
channel to which the
audio signal source is
connected to LINE.

Audio equipment

AUDIO IN switch: At the factory setting, when the audio cable is connected to either the AUDIO IN CH-1 or CH-2 connector, the signal input to the AUDIO IN CH-1 or CH-2 connector is automatically selected as the signal to be recorded. This is true regardless of the AUDIO IN switch setting. (This is called XLR connection automatic detection function.)

When the XLR connection automatic detection function is set to OFF on the VTR MODE 1 page of the MAINTENANCE menu, set the AUDIO IN switch corresponding to the channel to which the audio equipment is connected to REAR.

AUDIO IN for CH-1
or CH-2

Line input connection

5-6 Tripod Mounting

You can easily mount and dismount the camcorder on a tripod by using the VCT-14 tripod adaptor (not supplied).

1 Attach a tripod adaptor to the tripod.

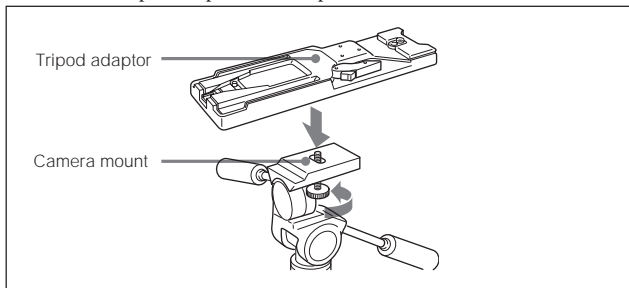

2 Mount the camcorder on a tripod adaptor.

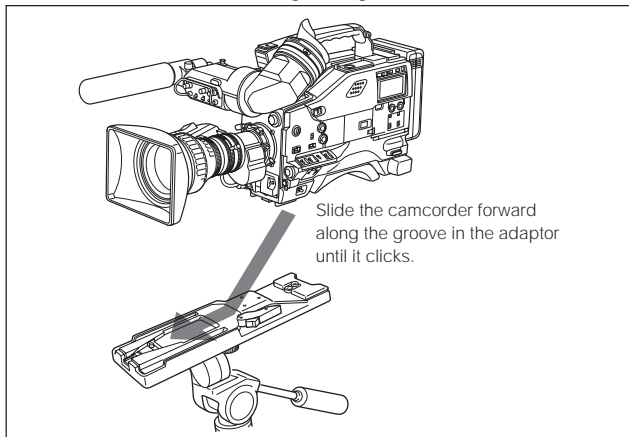

Removing the camcorder from a tripod adaptor

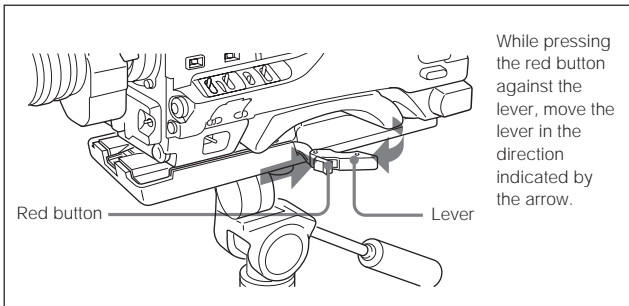

Removing the camcorder from a tripod adaptor

Note

A tripod adaptor pin may remain in the engaged position even after the camcorder is removed. If this happens, press the red button against the lever a second time and move the lever as shown below until the pin returns to the stowed position. If the pin remains in the engaged position, you will not be able to mount the camcorder on the tripod adaptor.

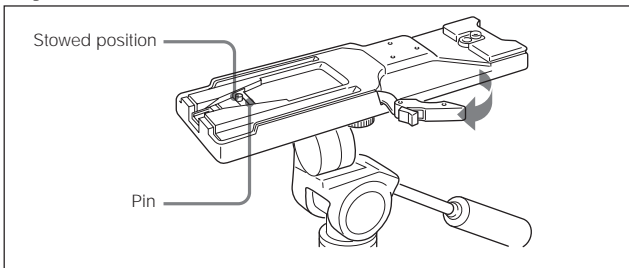

If the pin remains in the engaged position

5-7 Attaching the Shoulder Strap

Attach the supplied shoulder strap as shown below.

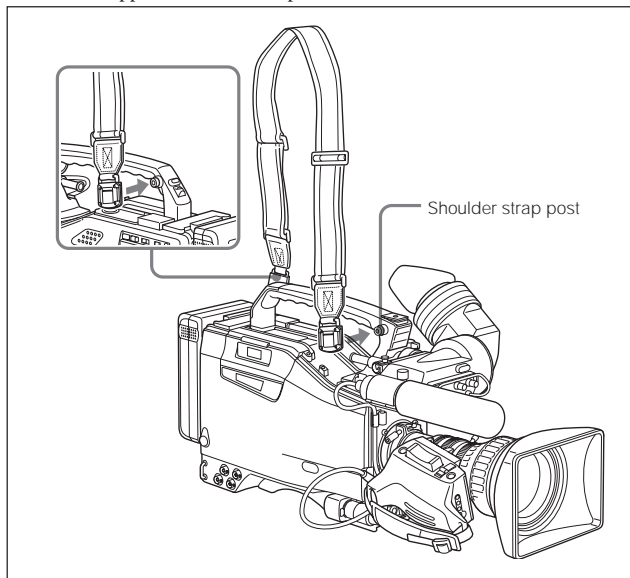

Attaching the shoulder strap

Attaching Clip

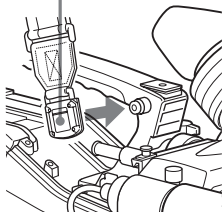

Pull up the strap to lock the fitting.

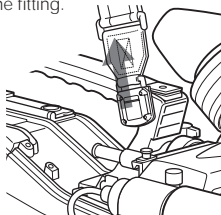

Attaching the shoulder strap

Removing

Press here and pull in the direction shown by the arrow to release.

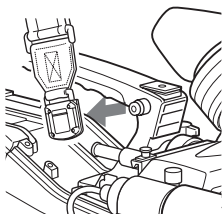
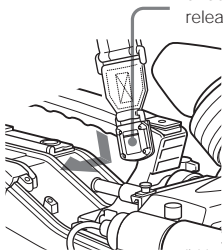

Removing the shoulder strap

5-8 Adjusting the Shoulder Pad Position

You can shift the shoulder pad from its center position (factory setting) backward by up to 10 mm (3/8 inch) or forward by up to 25 mm (1 inch). This adjustment helps you get the best balance for shooting with the camcorder on your shoulder.

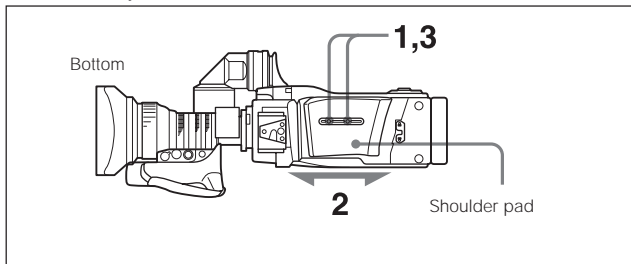

Adjusting the shoulder pad position

- 1** Loosen the two screws.
- 2** Slide the shoulder pad backward or forward until it is in the most convenient position.
- 3** Tighten the screws.

Note

Do not remove screws instead of loosening them. If you have removed them, be sure to use the screws you removed, or screws of the same length (8 mm). If you fasten the shoulder pad using longer screws, they may damage parts inside the unit.

5-9 Putting On the Rain Cover

Attach a rain cover as illustrated below. You can operate various switches and controls, and mount the camcorder on the tripod adaptor with the rain cover attached.

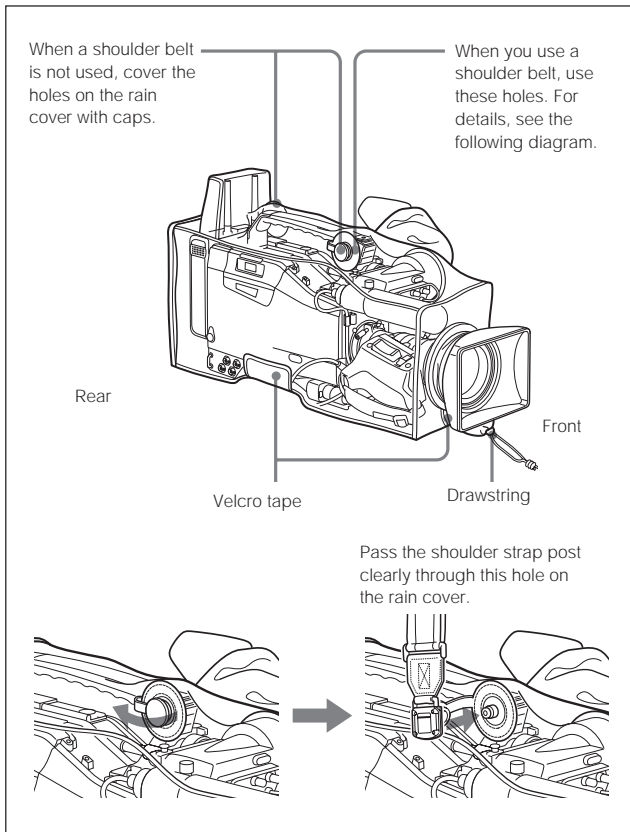

Insert the viewfinder barrel here with the eyecup out and fasten the drawings around the eyecup.

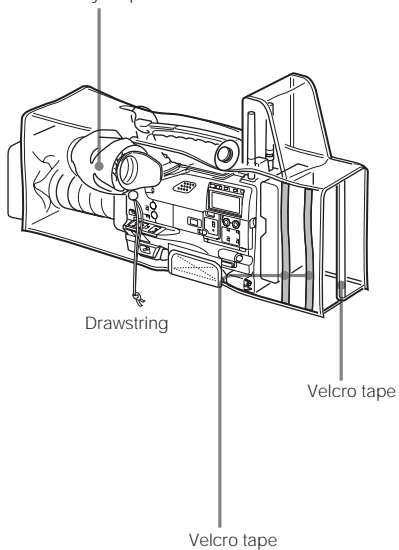

5-10 Connecting the Remote Control Unit

Connecting the RM-B150 Remote Control Unit (not supplied) enables remote control of the principal camera functions.

Connecting the remote control unit to the REMOTE connector (8-pin) automatically puts the camcorder into remote control mode. If you disconnect the remote control unit, remote control mode is canceled.

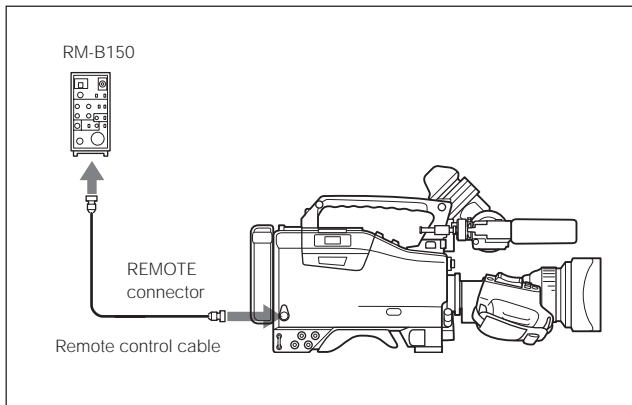

Connecting the remote control unit

When connecting the remote control unit to the camcorder

- The following switches on the camcorder will not function:
 - GAIN switch
 - OUTPUT/DCC switch
 - WHITE BAL switch
 - AUTO W/B BAL switch
 - SHUTTER ON/OFF/SEL switch
 - TURBO GAIN button (ASSIGN 1 switch to which the TURBO GAIN function is assigned)

-
- VTR START button (VTR button on the lens and the ASSIGN 1 switch to which the REC SWITCH function is assigned) (When the VTR START/STOP item on the FUNCTION 3 page of the MAINTENANCE menu is set to RM.)

For detailed information on this function, see the following “Function of the VTR START button when the remote control unit is connected”.

- When you connect the remote control unit, the settings of the paint adjustment that were in effect the last time the remote control unit was used are recalled.

Function of the VTR START button when the remote control unit is connected:

You can select the function of the VTR START button on the camcorder (also, VTR button on the lens and the ASSIGN 1 switch to which the REC START/STOP function is assigned) when the remote control unit is connected, using the VTR START/STOP item on the FUNCTION 3 page of the MAINTENANCE menu.

Not to activate the VTR START button on the camcorder: Select RM.

To activate the VTR START button on the camcorder: Select CAM. In this case, the VTR START button on the remote control unit is not activated.

To activate the VTR START button on both the camcorder and the remote control unit: Select PARA.

When removing the remote control unit from the camcorder

The setting of the camcorder returns to the setting in effect before the remote control unit was connected.

By setting the menu setting, the setting of the paint adjustment made with the remote control unit can be retained even after the remote control unit is removed from the camcorder.

For details, see “Structure of the paint adjustment data” on the next page.

5 When connecting the monitor to the MONITOR OUT connector of the remote control unit

The MONITOR connector of the RM-B150 (BNC type) outputs the same signal as that from the TEST OUT connector on the camcorder. When the HKDW-702 is installed, you can also connect an NTSC monitor.

When you connect the HD monitor, select the HD-Y signal as the output signal from the TEST OUT connector on the OUTPUT SET page of the USER menu.

When connecting an NTSC monitor, select the SD signal (analog composite video).

For details, see “4-8-2 Selecting the Output Signals” on page 4-101.

Use the black cable supplied with the RM-B150 to connect the monitor to the MONITOR connector on the RM-B150.

Structure of the paint adjustment data

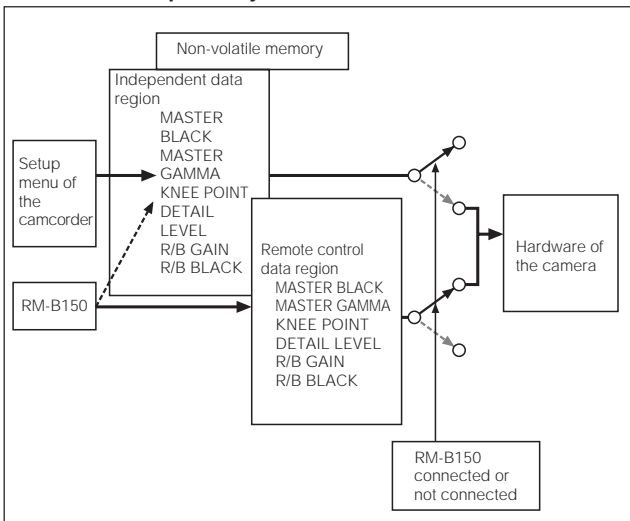

As the illustration above shows, non-volatile memory of the camcorder consists of two regions: one is the independent data region that becomes effective when the remote control unit is not connected, and the other is the remote control data region that becomes effective when the remote control unit is connected. Paint adjustment data is automatically selected depending on whether or not the remote control unit is connected to the camcorder.

Thus, when the remote control unit is connected to the camcorder, the effective data region is switched to the remote control data region and the settings of the paint adjustment that were in effect the last time the remote control unit was used are recalled.

Settings of the absolute value volume controls ¹⁾ and absolute value switches ²⁾ are overwritten by those on the remote control unit after the remote control unit is connected.

When the remote control unit is removed from the camcorder, the independent data region becomes effective. Thus the camcorder will return to the settings that were in effect before the remote control unit was connected.

When RM COMMON MEMORY is set to ON on the FUNCTION 3 page of the MAINTENANCE menu, you can use settings of the paint adjustment data stored in the independent data region even if you connect the remote control unit. In this case, the settings stored in the independent data region will be renewed when you change the settings on the remote control unit. Thus, the settings of the paint data made with the remote control unit can be retained even if the remote control unit is removed. However, if the switch position on the remote control unit differs from the one on the camcorder, the switch position on the camcorder takes precedence over that on the remote control unit. Also, it is possible to keep the settings that are in effect before you connect the remote control unit. In this case, you should set the volume to the relative mode on the remote control unit.

For details, refer to the instruction manual supplied with the RM-B150.

1) Absolute value volume control

The data corresponding to the rotation degree (position) of the volume controls is output. The data corresponding to the rotation amount is called the relative value volume.

2) Absolute value switch

Like the toggle switches or slide switches (except the momentary switches), the switches (or controls) whose positions must coincide with their functions are called absolute value switches.

6-1 Testing the Camcorder Before Shooting

Check the functions of the camcorder before setting out for a shooting session, preferably by operating the camcorder together with a color video monitor.

6-1-1 Preparations for Testing

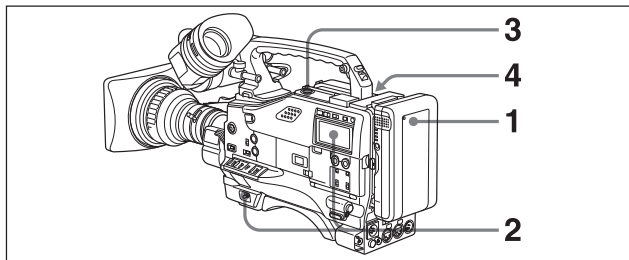

- 1 Attach a fully charged battery pack.
- 2 Set the POWER switch to ON and check that the HUMID indicator does not appear and that the BATT indicator shows at least five segments.
 - If the HUMID indicator appears, wait until it disappears.
 - If the BATT indicator does not show at least five segments, replace the battery pack with a fully charged one.
- 3 Check that there are no obstructions near the cassette lid, and then press the EJECT button to open the cassette lid.
- 4 After checking the points below, load the cassette and close the cassette lid.
 - The cassette is not write-protected.
 - There is no slack in the tape.
 - Condensation does not form in the tape.

Condensation

If you move the camcorder from a very cold place to a warm place, or use it in a damp location, condensation may form on the head drum. Then, if the camcorder is operated in this state, the tape may adhere to the drum and cause a failure or even permanent damage. Do the following to prevent this from happening.

- When moving the camcorder from a cold place to a warm place, be sure no cassette is loaded in the camcorder.
- Whenever you turn on the power, check that the HUMID indicator does not appear. If it appears, wait until it disappears before loading a cassette.

For more information, see “3-1-1 Loading and Unloading a Cassette” on page 3-1 and Section “6-3 Operation Warnings” on page 6-14.

6 6-1-2 Testing the Camera

Set the switches and selectors as follows.

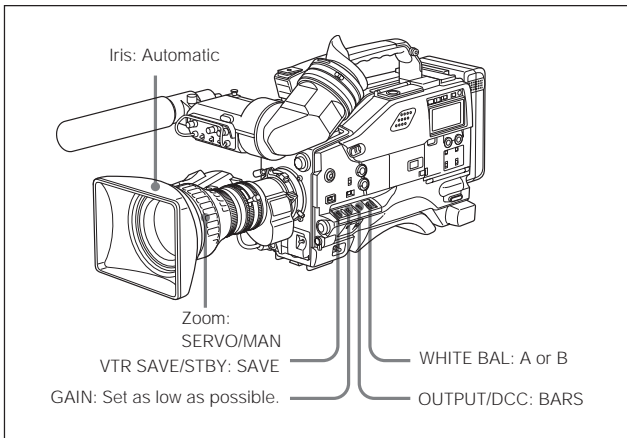

Testing the viewfinder

- 1 Adjust the position of the viewfinder.
- 2 Check that the color bars are displayed in the viewfinder, and adjust the BRIGHT, CONTRAST, and PEAKING controls to give the best color bar display.
- 3 Check each of the following operations.
 - The menu is displayed on the viewfinder screen.
 - Turn the MENU knob and check that the menu page changes to the next page.
 - Push the MENU knob and check that settings of each item of the selected page are displayed.
 - Turn the MENU knob and check that the arrow (→) mark moves within the page.
 - Push the MENU knob and check that the arrow (→) mark placed before the item changes to the circle (●) and the circle (●) placed before the setting of the item changes to the question mark (?).
 - Turn the MENU knob and check that the setting of the selected item or ON/OFF changes.
- 4 Set the OUTPUT/DCC switch to CAM, and change the ND FILTER selector position in the sequence of 1, 2, 3, 4. Check that the FILTER indicator on the viewfinder screen displays the correct numbers.
- 5 Check each of the following operations and make sure that the **!** indicator lights if the corresponding item has been turned on in the '!' LED page of the USER menu.
 - Set the gain to anything but 0 dB by using the GAIN selector and the GAIN SW page of the OPERATION menu.
 - Set the SHUTTER selector to ON.
 - Set the WHITE BAL switch to PRST.

(Continued)

-
- Use the lens extender.
 - Set the ND FILTER selector to anything but “1”.
 - Set the reference value of the auto iris to other than the standard value.

- 6** Push the SHUTTER selector from ON to SEL repeatedly, and check that the shutter setting changes on the viewfinder screen.
- 7** Pointing the camera at a suitable subject, focus the camera and check the picture on the viewfinder screen.
- 8** Set both of the AUDIO IN switches to FRONT, and check that when sound is input to a microphone connected to the MIC IN connector on the front of the camcorder, the audio level indicators appear on the viewfinder screen.
- 9** Check that setting the ZEBRA switch to ON and OFF makes the zebra pattern appear and disappear on the viewfinder screen.

Note

The current display status may inhibit one or more of the displays or operations mentioned in steps **3** to **9**. If this happens, set the desired items in the VF DISP1 and VF DISP 2 pages of the USER menu.

For details, see “4-7-2 Selecting the Display Items” on page 4-70.

Testing the iris and zoom functions

- 1** Set the zoom to automatic zoom mode and check that the power zoom operates correctly.
- 2** Set the zoom to manual zoom mode and check the zoom functions manually.

-
- 3** Set the iris switch on the lens to **AUTO** and point the camera at objects of different brightness. Check that the automatic iris adjustment operates correctly.
 - 4** Set the iris switch on the lens to **MANUAL** and check that turning the iris ring manually adjusts the iris correctly.
 - 5** Set the iris switch on the lens back to **AUTO** and check the following points when the **GAIN** selector is moved from **L** to **M** to **H**.
 - For objects of the same brightness, the iris is adjusted to correspond to the change in setting.
 - The gain indicator on the viewfinder screen changes to correspond to the change in setting.
 - 6** If an extender mechanism is incorporated in your lens, put the extender lever of the lens into the **2x** position and check the following points.
 - **EX** appears at the left top on the viewfinder.
 - The auto iris functions correctly.

6-1-3 Testing the VTR

Perform tests (1) to (7) consecutively.

(1) Testing the tape transport functions

- 1** Set the **VTR SAVE/STBY** switch to **SAVE** and check that the **VTR SAVE** indicator in the viewfinder goes on.
- 2** Set the **VTR SAVE/STBY** switch to **STBY** and check that the **VTR SAVE** indicator in the viewfinder goes off.
- 3** Set the **F-RUN/SET/R-RUN** switch to **R-RUN**. *(Continued)*

-
- 4** Set the DISPLAY switch to CTL.
 - 5** Press the VTR START button and check the following points.
 - The tape reels are turning.
 - The counter indication is changing.
 - The REC indicator in the viewfinder is on.
 - The RF and SERVO indicators on the display panel are off.
 - 6** Press the VTR START button again and check that the tape stops and that the REC indicator in the viewfinder goes off.
 - 7** Repeat the checks of steps **5** and **6**, this time using the VTR button on the lens.
If the REC SWITCH function is assigned to the ASSIGN 1 switch, repeats the checks of steps 5 and 6, this time using the ASSIGN 1 button.
 - 8** Press the RESET button and check that the counter display goes to “00:00:00:00”.
 - 9** Turn on the LIGHT switch and check that the display panel is illuminated.
 - 10** Hold down the REW button to rewind the tape for a while, then press the PLAY button. Check that the rewind and playback functions operate normally.
 - 11** Press the STOP button and press the F FWD button. Check that the fast forward function operates normally.

(2) Testing the automatic audio level adjusting functions

- 1** Set the AUDIO IN CH-1 and CH-2 switches to FRONT.

-
- 2** Set the AUDIO SELECT CH-1 and CH-2 switches to AUTO.
 - 3** Set the CH-1/2 / CH-3/4 switch to CH-1/2.
 - 4** Aim the microphone connected to the MIC IN connector at a suitable sound source. Check that the level indications for both channels 1 and 2 correspond to the sound level.
 - 5** Set the AUDIO IN CH-3 and CH-4 switches to F.
 - 6** Set the CH-1/2 / CH-3/4 switch to CH-3/4.
 - 7** Aim the microphone connected to the MIC IN connector at a suitable sound source. Check that the level indications for both channels 3 and 4 correspond to the sound level.
 - 8** Be sure to reset the CH-1/2 / CH-3/4 switch to CH-1/2 after checking the channels 3 and 4.

(3) Testing the manual audio level adjusting functions

- 1** Set the AUDIO IN CH-1 and CH-2 switches to FRONT.
- 2** Set the AUDIO SELECT CH-1 and CH-2 switches to MANUAL.
- 3** Turn the MIC LEVEL knob. Check that the audio level meter in the display panel increases by turning it counterclockwise as seen from the front of the camera.

(4) Testing the earphone and speaker

- 1** Turn the MONITOR control and check that the speaker volume changes accordingly.

-
- 2** Connect an earphone to one EARPHONE jack. Check that the speaker sound is cut off and that you can hear the sound from the microphone in the earphone.
 - 3** Turn the MONITOR control and check that the earphone volume changes accordingly.
 - 4** Connect the earphone to the other EARPHONE jack. Check the earphone by repeating step 3.

(5) Testing external microphones

- 1** Connect external microphones to the AUDIO IN CH-1/CH-2 connectors.
- 2** Set the LINE/MIC/+48V ON switch to +48V ON or MIC in accordance with the type of the microphone power supply.
If the microphone you connect to AUDIO IN CH-1 or CH-2 is of the internal batteries type, set the appropriate LINE/MIC/+48V ON switch to MIC.
If the microphone you connect to AUDIO IN CH-1 or CH-2 is of the external power supply type, set the appropriate LINE/MIC/+48V ON switch to +48V ON.
- 3** Set the AUDIO IN switches to REAR.
- 4** Aim the microphones at a sound source.
- 5** Check that the audio level meter in the display panel and the audio level indicators in the viewfinder reflect the changing sound level.

(6) Checking the XLR connection automatic detection function

Before starting to check, remove the microphone connected to the MIC IN connector if it is connected.

- 1** Perform operations of steps 1 and 2 explained in “(5) Testing external microphones”.
- 2** Set the AUDIO IN switches to FRONT.
- 3** Perform operations of steps 4 and 5 explained in “(5) Testing external microphones”.

When performing the operation of step 5 in “(5) Testing external microphones”, if the audio level meters in the display panel and audio level indicators in the viewfinder reflect the changing sound level, the function of the XLR connection automatic detection works correctly.

If it does not reflect the changing sound level, the function of the XLR connection automatic detection is set to OFF. Set REAR XLR AUTO to ON on the VTR MODE 1 page of the MAINTENANCE menu.

If it does not reflect even after you set REAR XLR AUTO to ON, the XLR connection automatic detection function does not work correctly.

(Continued)

(7) Checking the functions of the user bits and time code

- 1** Set the user bits as required.

For more information see “4-5-3 Setting the User Bits” on page 4-38.

- 2** Set the time code.

For more information, see “4-5-1 Setting the Time Code” on page 4-35.

- 3** Set the F-RUN/SET/R-RUN switch to R-RUN.

- 4** Press the VTR START button, and check that the tape starts and that the counter indication changes.

6

- 5** Press the VTR START button again, and check that the tape stops and that the counter indication also stops changing.

- 6** Set the F-RUN/SET/R-RUN switch to F-RUN, and check that the counter indication changes regardless of whether the tape is running.

- 7** Set the DISPLAY switch to DATA and the DATA DISPLAY switch to U-BIT, and check that the user bit value that was set is displayed.

6-2 Maintenance

6-2-1 Cleaning the Video Heads

To clean the video heads, use a Sony BCT-HD12CL Cleaning Cassette. Follow the instructions given with the cleaning cassette, as incorrect or excessive use could damage the video heads.

To clean the heads, follow the procedure below.

- 1** Load the cleaning cassette according to the procedure described in “Loading a cassette” (page 3-1).
- 2** After the cleaning cassette is inserted, the tape runs automatically in PLAY mode for about 3 seconds to clean the head.
- 3** After the tape runs, the cleaning cassette is automatically ejected.

Note

Do not run the cleaning cassette 5 or more times consecutively.

6-2-2 Cleaning the Viewfinder

Use a dust blower to clean the CRT screen and mirror inside the barrel. Clean the lens and protecting filter with a commercially available lens cleaner.

Caution

Never use organic solvents such as thinners.

Disassembling the eyepiece for cleaning

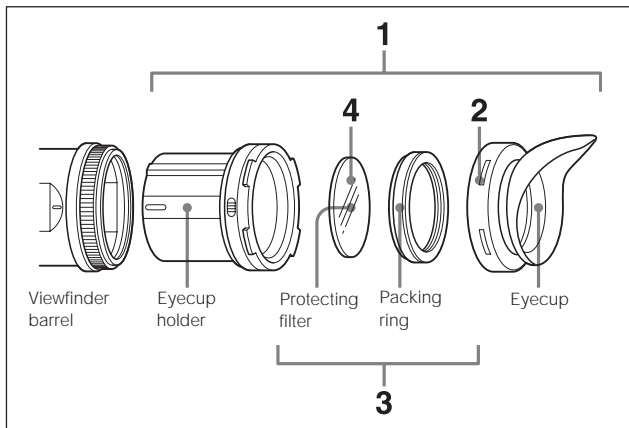

- 1** Detach the eyepiece from the viewfinder barrel.

For the detaching procedure, see the following “5-2-4 Detaching the Eyepiece” on page 5-12.

- 2** Remove the eyecup from the eyecup holder.
- 3** Remove the protecting filter, together with the packing ring, from inside the eyecup folder.
- 4** Detach the protecting filter from the packing ring.

Fog-proof filter

Depending on the temperature and humidity, the protecting filter may mist because of vapor or your breath. To ensure that the viewfinder is always clear, replace the protecting filter with a fog-proof filter (Part No. 1-547-341-11, not supplied).

Fitting the fog-proof filter

Replace the protecting filter on the packing ring with the fog-proof filter. Be sure to correctly assemble the fog-proof filter, the packing ring, and the eyecup so that the reassembled eyepiece is waterproof.

Note

When cleaning the fog-proof filter, wipe it very gently with a soft cloth to avoid impairing the anti-fogging coating.

6-3 Operation Warnings

When a problem occurs either at power on or during operation, warnings are given by the WARNING indicator and TALLY indicator, in the display panel, and in the viewfinder. The speaker and earphone also give audible warnings.

Operation warnings

Display panel	Indicators in the viewfinder			Warning sounds	Problem	VTR action	Corrective action	
Warning/Battery status indication	Flashing/continuous	:Continuous :1 flash/s	:2 flashes/s :4 flashes/s	●●●●●●●●●● 4 beeps/s ●●●●●●●●●● :1 beep/s ●●●●●●●●●● : Continuous beep				
RF	Continuous ^{a)}			●●●●●●●●●● ^{a)}	Video head gap clogged or problem in recording circuit.	After clogged head is detected, recording continues but is substandard.	Clean the heads. If recording is still substandard, turn off the power and consult your Sony representative.	
SERVO	Continuous			●●●●●●●●●●	Servo lock lost.	Recording continues but is substandard.	Turn off the power and consult your Sony representative. Note that this indication may be given momentarily when the tape starts moving, but this does not indicate a problem.	
HUMID	Continuous			●●●●●●●●●● ^{a)} ●●●●●●●●●● ^{b)}	Condensation on the head drum.	Recording continues but stops if the tape sticks to the head drum. Playback, fast forward, and rewind do not operate.	Stop the tape and wait until the HUMID indicator disappears.	
SLACK	Continuous			●●●●●●●●●●	The tape cannot be wound properly.	VTR stops. An error code appears in the time code display section of the display panel. Look up the error code in the Maintenance Manual.	Remove the cassette by the method described in the Maintenance Manual. Close the cassette lid without loading a cassette, turn off the power, and consult your Sony representative.	
TAPE ^{e)}	Flashing ^{a)}	^{a)}		●●●●●●●●●●	Near the end of tape.	Operation continues.	Be prepared to change the cassette.	
TAPE and E	Flashing			●●●●●●●●●●	End of tape.	Record, playback, and fast forward do not operate.	Change the cassette or rewind the tape.	
BATT	Flashing				●●●●●●●●●● ^{d)}	Low battery.	Operation continues. ^{e)}	Change the battery.
BATT and E	Flashing				●●●●●●●●●●	Dead battery.	Operation stops.	Change the battery.
Time counter ^{f)}					Playback of a tape recorded with a format different from that of the camcorder	Audio is muted even though the picture is played back.		

a) During recording

b) During playback, fast forward, or rewind

c) Also, "5-0" appears for the tape remaining indication.

d) During recording or stop mode

e) During auto interval recording mode, once the VTR stops.

f) The current format of the camcorder and the format with which the tape has been recorded are displayed in turn on the time counter display.

Operation/error messages

An operation or error message is displayed in the operation/error message display area in the viewfinder.

Operation/error message	Meaning
AUTO INTERVAL **M**S	Indicates the camera is in the Auto Interval Rec mode. **M**S indicates the shooting interval.
MANU INTERVAL *FRAME	Indicates the camera is in the single trigger mode of the Manual Interval Rec mode. *FRAME indicates the number of frames.
INTERVAL **S(M/H)*FRAME	Indicates the camera is in the continuous trigger mode of the Manual Interval Rec mode. **S(M/H) indicates the trigger interval and *FRAME indicates the number of frames.
LOW LIGHT	Appears, depending on the setting, to indicate the subject illumination is inadequate.
TAPE REC INH.	Appears when recording on a write-protected cassette.
TELE FILE MEMORY FULL	Appears when you load a cassette with a full memory label.
TELE FILE NEAR FULL	Appears when you load a cassette with a memory label that is nearly full.

Operation/error message	Meaning
Retake Search Failed	Appears when the camcorder fails to position the tape at recording starting point when recording using the re-take function. ^{a)}
Humid Disturbed INT REC	Appears when there are portions where recording has failed due to condensation while shooting pictures at intervals (using the interval rec function).
ON-BOARD BATTERY EMPTY	Appears when the backup battery for the internal clock has been used up. ^{b)}

- a) In this case, position the tape at the point where you want to start the recording manually.
- b) To replace the backup battery, contact your nearest Sony dealer.

Notes on CCD image sensors

Vertical smear

Smear tends to be produced when an extremely bright object is being shot; it is more likely to occur with a faster electronic shutter speed.

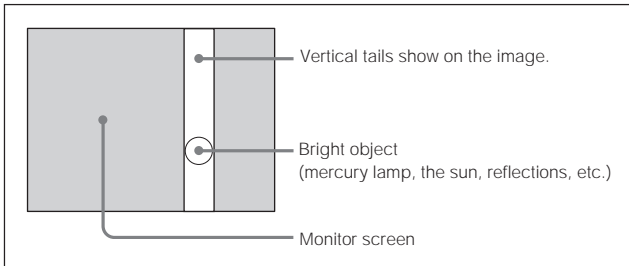

Vertical smear

Aliasing

When patterns of stripes or lines are shot, they may appear jagged.

Specifications

Power voltage

12 $^{+5.0}_{-1.0}$ V DC

Power consumption

HDW-730: 33 W (with 12 V DC supply, when recording)

HDW-750/750P: 34 W (with 12 V DC supply, when recording)

Operating temperature

0°C to +40°C (32°F to 104°F)

Operating humidity

25% to 85% (relative humidity)

Storage temperature

-20°C to +60°C (-4°F to +140°F)

Mass

Approx. 5.4 kg (11 lb 14 oz) (with viewfinder, cassette, and BP-L60A Battery Pack)

Dimensions

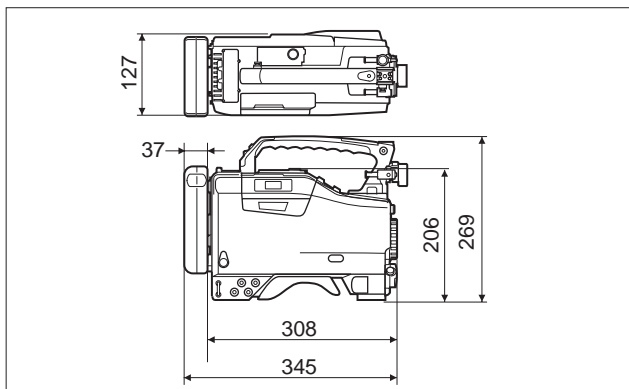

Dimensions in mm

Video Camera Section

General

Imager

$\frac{2}{3}$ -type CCD with 2,000,000 pixels

Effective picture elements

1920 (H) \times 1080 (V)

Imager Configuration

RGB 3 CCDs

Spectral system

F1.4 prism system (with quartz filter)

Built-in filters

CC filter

A: Cross filter

B: 3200K

C: 4300K

D: 6300K

ND filter

1: Clear

2: $\frac{1}{4}$ ND

3: $\frac{1}{16}$ ND

4: $\frac{1}{64}$ ND

Lens mount

Special bayonet type

Sensitivity

89.9% reflection chart, 2000 lx (F10 standard)

VTR Section

General

Usable cassette tapes

BCT-22HD/40HD 1/2-inch HDCAM cassette tapes

Tape speed

Approx. 96.7 mm/s (at 30 frames) (for 59.94I format)

Approx. 80.6 mm/s (at 25 frames) (for 50I/25PsF format)

Record/playback time

40 minutes (using BCT-40HD video cassette) (for 59.94I format)

48 minutes (using BCT-40HD video cassette) (for 50I/25PsF format)

Fast forward time

Approx. 5 minutes (using BCT-40HD video cassette)

Rewind time

Approx. 5 minutes (using BCT-40HD video cassette)

Continuous recording time

Approx. 90 minutes (using BP-L60A Battery Pack)

Approx. 40 minutes (using BP-M50 Battery Pack)

Approx. 120 minutes (using BP-M100 Battery Pack)

Digital video

Digital video signal

Sampling frequency	Y	74.25 MHz
	P _B /P _R	37.125 MHz
Quantization	10 bits/sample (8 bits/sample for compression processing)	
Compression	Coefficient recording system	
Channel coding	S-NRZI PR-IV	
Error correction	Reed-Solomon code	
Error concealment	Adaptive three dimensional	

Audio (with standard playback machine)

Frequency response	20 Hz to 20 kHz ^{+0.5} _{-1.0} dB
Dynamic range	85 dB min. (emphasis ON)
Distortion	0.08% max.
Cross talk	-70 dB max.
Wow and flutter	Below measurable limit

Input/output connectors

Signal inputs

AUDIO IN CH-1/CH-2 (XLR, 3-pin, female)

-60 dBu/+4 dBu

(0 dBu = 0.775 V_{rms}.)

MIC IN (XLR, 5-pin, female)

-60 dBu

A

GENLOCK IN (BNC type)

1.0 V_{p-p}, 75 Ω

TC IN (BNC type)

0.5 V to 18 V_{p-p}, 10 k Ω

Signal outputs**TEST OUT (BNC type)**

1.0 V_{p-p}, 75 Ω, unbalanced

VBS/SDI OUT (BNC type) (only when an HKDW-702 is installed)

75 Ω, unbalanced

VBS OUT: 1.0 V_{p-p}

SDI OUT: 0.8 V_{p-p}

HD SDI OUT (BNC type)

0.8 V_{p-p}, 75 Ω, unbalanced

AUDIO OUT (XLR, 5-pin, male)

0 dBm

TC OUT (BNC type)

1.0 V_{p-p}, 75 Ω

EARPHONE (minijack)

8 Ω, $-\infty$ to -18 dBs variable

Others**DC IN (XLR, 4-pin, male)**

11 to 17 V DC

DC OUT (4-pin)

11 to 17 V DC, maximum current 0.1 A

LENS (12-pin)**REMOTE (8-pin)**

Supplied Accessories

HD Electronic Viewfinder (HDVF-20A) (1)

Stereo microphone (super cardioid directional, external power supply type) (1)

Shoulder Strap (1)

Lens mount securing rubber (1)

Operation Manual (1)

CD-ROM (1) (Only for an HDW-750P)

A**Recommended Additional Equipment****Power supply and related equipment**

BP-L60A Battery Pack

BC-L120 Battery Charger (for BP-L60A Battery Pack)

BP-M50/M100 Battery Pack

BC-M50 Battery Charger (for BP-M50/M100 Battery Pack)

AC-550/550CE AC Adaptor

AC-DN2B AC Adaptor

HDCAM cassette tapes

BCT-22HD/40HD

Memory label

MLB-1M-100

Camera adaptor

HDCA-901

Memory Stick

MSA-8A (8MB)

MSA-16A (16MB)

MSA-32A (32MB)

MSA-64A (64 MB)

Viewfinder and related equipment

BKW-401 Viewfinder Rotation Bracket

Fog-proof filter (Part No. 1-547-341-11)

Lens assembly (farsighted) (Part No. A-8262-537-A)

Lens assembly (low magnification) (Part No. A-8262-538-A)

Lens assembly (standard magnification with special compensation for aberrations) (Part No. A-8267-737-A)

Optical attachments

ND filter ($1/8$ ND) (Part No. 3-174-685-01)

ND filter ($1/32$ ND) (Part No. 3-174-683-01)

Cross filter (Part No. 3-174-682-01)

Mount ring (Part No. 3-186-442-01)

Consult your Sony representative for more information about these filters.

Equipment for remote control

RM-B150 Remote Control Unit

Audio equipment

C-74 microphone

ECM-MS5 stereo microphone

CAC-12 Microphone Holder

CCXA-53 Audio Cable

CRS-3P Cradle Suspension

WRR-855A/855B UHF Synthesized Tuner Unit

WRR-810A/860A/862A/862B UHF Portable Tuner

WRT-27 UHF Transmitter

BTA-27 UHF Portable Tuner Attachment Kit

For Audio equipment described above, confirm whether the connector is male or female and the number of pins on the connector.

The audio input connectors of the camcorder are female and 3-pin and the audio output connectors are male and 5-pin. A converting adaptor may be required depending on the audio equipment to be connected to the camcorder.

Extension boards

HKDW-702 DOWN CONVERTER BOARD

HKDW-703 PICTURE CACHE BOARD

HKDW-704 GPS UNIT

Equipment for maintenance and easier handling

BCT-HD12CL Cleaning Cassette

Hard Carrying Case

LC-DS300SFT Soft Carrying Case

Tripod Adaptor VCT-14

Rain cover

WRR Tuner Fitting (service part number: A-8278-057-A)

Maintenance Manual

Design and specifications are subject to change without notice.

A

Menu List

This section briefly explains menus that the camcorder provides for adjustments and settings using tables.

For the menu configuration, see “4-6-1 Menu Configuration” on page 4-47. Chapter 4 elaborates on adjustments and settings to be made using the USER menu.

This manual also explains some of adjustments and settings to be made using the OPERATION menu, PAINT menu, MAINTENANCE menu, FILE menu and DIAGNOSIS menu.

For detailed information on these menus, refer to the Maintenance Manual.

OPERATION Menu List

Some pages of the OPERATION menu have been registered in the USER menu at the factory. The USER MENU CUSTOMIZE menu allows you to edit the USER menu to suit your requirements.

This section describes the list of the OPERATION menu pages first registered in the USER menu. For detailed information on functions, see the reference pages given in the table.

The section then describes the list of the pages on the OPERATION menu excluding those registered in the USER menu.

A

Page	Setting items	Reference page
OUTPUT SEL	HD SDI OUT	4-101
	REAR BNC OUT SEL	
	TEST OUT SELECT	
	DOWN CON MODE	
FUNCTION 1	ASSIGN SW <1>	3-22, 3-29, 3-52, 4-37, 4-109, 5-18
	ASSIGN SW <2>	
	FRONT MIC SELECT	
	DF/NDF ^{a)}	
	END SEARCH	
	LOOP/INTVAL REC	
	LOOP REC TIME	
	TAKE TOTAL TIME	
	REC TIME	
	PRE-LIGHTING	
	NUMBER OF FRAME	
TRIGGER INTERVAL		
VF DISP 1	VF DISP	4-71
	VF DISPLAY MODE	
	DISP EXTENDER	
	DISP FILTER	
	DISP WHITE	
	DISP GAIN	
	DISP SHUTTER	
	DISP AUDIO	
	DISP TAPE	
	DISP IRIS	

a) Only for a camcorder which operates with the 59.94I format

Page	Setting items	Reference page
VF DISP 2	DISP ZOOM	4-72
	DISP COLOR TEMP.	
	DISP VOLT	
	DISP DC IN	
	DISP TIME CODE	
	DISP WRR RF LVL	
"!LED	GAIN < >	2-47
	SHUTTER < >	
	WHT PRESET < >	
	ATW RUN < >	
	EXTENDER < >	
	FILTER < >	
	OVERRIDE < >	
MARKER 1	MARKER	4-75
	CENTER	
	CENTER MARK	
	SAFETY ZONE	
	SAFETY AREA	
	ASPECT	
	ASPECT SELECT	
	ASPECT MASK	
	ASPECT MASK LVL	
	100% MARKER	
GAIN SW	GAIN LOW	4-98
	GAIN MID	
	GAIN HIGH	
	GAIN TURBO	
	TURBO SW IND.	

Page	Setting items	Reference page
VF SETTING	ZEBRA	4-78
	ZEBRA SELECT	
	ZEBRA1 DET.LVL	
	ZEBRA2 DET.LVL	
	ASPECT	
	VF DETAIL LEVEL	
	VF DTL H LEVEL	
	VF DTL V LEVEL	
AUTO IRIS	IRIS OVERRIDE	4-21
	IRIS SPEED	
	CLIP HIGH LIGHT	
	IRIS WINDOW	
	IRIS WINDOW IND.	
	IRIS VAR WIDTH	
	IRIS VAR HEIGHT	
	IRIS VAR H POS	
	IRIS VAR V POS	
SHOT ID	ID-1	4-84
	ID-2	
	ID-3	
	ID-4	
SHOT DISP	SHOT DATE	4-81
	SHOT TIME	
	SHOT MODEL NAME	
	SHOT SERIAL NO	
	SHOT ID SEL	
	SHOT BLINK CHARA	

Page	Setting items	Reference page
SET STATUS	STATUS ABNORMAL	4-93
	STATUS FUNTION	
	STATUS AUDIO	
	STATUS GPS ^{a)}	
USER FILE	USER FILE SAVE	4-122, 4-126, 4-130,
	USER FILE LOAD	
	F.ID	
	USER PRESET	
LENS FILE	LENS FILE SELECT	4-116
	F.ID	
	F STOP	

a) Only when an HKDW-704 is installed.

The following is the list of the pages of the OPERATION menu that are not included in the USER menu at the factory.

Note

When the range of setting is surrounded by parenthesis () in the setting column, the setup value is the relative value. The range of setting in parenthesis () can be different from what shown in the manual depending on the setting in the layer lower than this menu.

Page	Items	Setting	Contents
FUNCTION 2	WHITE SWITCH 	MEM/ATW	Sets the function of the WHITE BAL B switch
	SHOCKLESS WHITE	OFF/1/2/3	Changes the white gain smoothly when operating the WHITE BAL switch
	LOW LIGHT	OFF/ON	Turns the warning display on or off when the video average level is less than the preset value.
	LOW LIGHT LEVEL	(-99 to 99)	Sets the level at which the LOW LEVEL function becomes effective.
	BATTERY WARNING	10%/20%	Selects the remaining amount of the alarm voltage when the Anton battery is connected.

Page	Items	Setting	Contents
MARKER 2	USER BOX	OFF/ON	Turns the box cursor on or off.
	USER BOX WIDTH	1 to 479	Width (from the center to right or left side)
	USER BOX HEIGHT	1 to 269	Height (from the center to top or bottom)
	USER BOX H POS.	(-480 to 479)	H position of the center
	USER BOX V POS.	(-270 to 269)	V position of the center
	CENTER H POS.	(-480 to 479)	H position of the center marker
	CENTER V POS.	(-270 to 269)	V position of the center marker
	ASPECT SAFE ZONE	OFF/ON	Turns the SAFETY MODE display on or off for the aspect mode selected in the ASPECT SELECT item on the MARKER 1 page.
	ASPECT SAFE AREA	80%/90%/92.5%/95%	Select the range of the aspect safety zone.

Page	Items	Setting	Contents
TEST OUT	TEST OUT MARKER	OFF/ON	Selects whether or not the marker signal is mixed to the output signal from the TEST OUT connector.
	TEST OUT VF DISP	OFF/ON	Selects whether or not the VF DISP display signal is mixed to the output signal from the TEST OUT connector.
	TEST OUT MENU	OFF/ON	Selects whether or not the MENU display signal is mixed to the output signal from the TEST OUT connector.
	TEST OUT ZEBRA	OFF/ON	Selects whether or not the ZEBRA display signal is mixed to the output signal from the TEST OUT connector.
	OUTPUT SELECT ^{a)}	Y/R/G/B	Selects the output signal from the TEST OUT or VBS/SDI OUT connector.

- a) When an HKDW-702 is installed, if Y is selected, the color signal is output from the connector with SD selected as its signal.

Page	Items	Setting	Contents
OFFSET WHT	OFFSET WHITE <A>	OFF/ON	ON: Adds the offset adjusted on this page to the white balance of channel A.
	WARM COOL <A>	Color temperature display	Sets the offset for the white balance of channel A, using the color temperature. Adjust the value while looking at the real image because error tends to be greater for adjustment of high color temperature.
	COLOR FINE <A>	(-99 to 99)	Adjusts the value more precisely if the adjustment by WARM-COOL <A> is not satisfactory.
	OFFSET WHITE 	OFF/ON	ON: Adds the offset adjusted on this page to the white balance of the channel B.
	WARM COOL 	Color temperature display	Sets the offset for the white balance of channel B, using the color temperature. Adjust the value while looking at the real image because error tends to be greater for adjustment of high color temperature.
	COLOR FINE 	(-99 to 99)	Adjusts the value more precisely if the adjustment by WARM-COOL is not satisfactory.

Page	Items	Setting	Contents
SHT ENABLE	SHUTTER ECS	OFF/ON	Sets the ECS mode to ON or OFF.
	SHUTTER 1/33 ^{a)}	OFF/ON	Set 1/33 shutter mode to ON or OFF.
	SHUTTER 1/50 ^{b)}	OFF/ON	Set 1/50 shutter mode to ON or OFF.
	SHUTTER 1/100 (1/60) ^{c)}	OFF/ON	Sets 1/100 (1/60) shutter mode to ON or OFF.
	SHUTTER 1/125	OFF/ON	Sets 1/125 shutter mode to ON or OFF.
	SHUTTER 1/250	OFF/ON	Sets 1/250 shutter mode to ON or OFF.
	SHUTTER 1/500	OFF/ON	Sets 1/500 shutter mode to ON or OFF.
	SHUTTER 1/1000	OFF/ON	Sets 1/1000 shutter mode to ON or OFF.
	SHUTTER 1/2000	OFF/ON	Sets 1/2000 shutter mode to ON or OFF.

a) only for a camcorder which operates with the 25PsF format

b) only for a camcorder which operates with the 25PsF format

c) 1/100 for a camcorder which operates with the 25 PsF/59.94I format
1/60 for a camcorder which operates with the 25 PsF/50I format

PAINT Menu List

Page	Items	Setting	Contents
SW STATUS	GAMMA	OFF/ON	Turns the gamma correction on or off.
	BLACK GAMMA	OFF/ON	Turns the black gamma correction on or off.
	MATRIX	OFF/ON	Turns the linear matrix correction on or off.
	KNEE	OFF/ON	Turns the knee correction on or off.
	WHITE CLIP	OFF/ON	Turns the white clipping correction on or off.
	DETAIL	OFF/ON	Turns the detail signal on or off.
	APERTURE	OFF/ON	Turns the aperture function on or off.
	FLARE	ON/OFF	Turns the flare function on or off.
	EVS	OFF/ON	Turns the EVS shutter on or off.
	TEST SAW	OFF/ ANALOG/ DIGITAL	Selects the test signal.

Page	Items	Setting	Contents
WHITE	COLOR TEMP <A>	Color temperature display	Sets the temperature of WHITE A.
	COLOR FINE <A>	(-99 to 99)	Adjusts the value more precisely when the color temperature adjustment through COLOR TEMP is not satisfactory.
	R GAIN <A>	(-99 to 99)	Only the value of R GAIN is changed.
	B GAIN <A>	(-99 to 99)	Only the value of B GAIN is changed.
	COLOR TEMP 	Color temperature display	Sets the temperature of WHITE B.
	COLOR FINE 	(-99 to 99)	Adjusts the value more precisely when the color temperature adjustment through COLOR TEMP is not satisfactory.
	R GAIN 	(-99 to 99)	Only the value of R GAIN is changed.
	B GAIN 	(-99 to 99)	Only the value of B GAIN is changed.

Page	Items	Setting	Contents
BLACK	MASTER BLACK	(-99 to 99)	Adjusts the master black level.
	R BLACK	(-99 to 99)	Adjusts the R black level.
	B BLACK	(-99 to 99)	Adjusts the B black level.
	MASTER FLARE	(-99 to 99)	Adjusts the flare level of the master.
	R FLARE	(-99 to 99)	Adjusts the R flare level.
	G FLARE	(-99 to 99)	Adjusts the G flare level.
	B FLARE	(-99 to 99)	Adjusts the B flare level.
	FLARE	OFF/ON	Turns the flare correction circuit on or off.
	OUTPUT SELECT ^{a)}	Y/R/G/B	Selects the output signal of VBS/SDI OUT and TEST OUT.

a) For detailed information on OUTPUT SELECT, see a) on page A-16.

A

Page	Items	Setting	Contents
GAMMA	GAMMA	OFF/ON	Turns the gamma correction function on or off.
	MASTER GAMMA	(-99 to 99)	Sets the master gamma correction curve.
	R GAMMA	(-99 to 99)	Sets the R gamma correction curve.
	G GAMMA	(-99 to 99)	Sets the G gamma correction curve.
	B GAMMA	(-99 to 99)	Sets the B gamma correction curve.
	OUTPUT SELECT ^{a)}	Y/R/G/B	Selects the output signal of VBS/SDI OUT and TEST OUT.
	GAMMA SELECT	STD/FILM	Selects the gamma table.
	GAM SEL (STD/FILM)	1 to 4	Select the gamma table of STD/FILM.

a) For detailed information on OUTPUT SELECT, see a) on page A-16.

Page	Items	Setting	Contents
BLK GAMMA	BLACK GAMMA	OFF/ON	Turns the black gamma correction on or off.
	BLK GAMMA RANGE	LOW/L.MID/H.MID/HIGH	Sets the range affected by black gamma.
	MASTER BLK GAMMA	(-99 to 99)	Adjusts the master black gamma.
	R BLACK GAMMA	(-99 to 99)	Sets the correction curve of the R black gamma.
	G BLACK GAMMA	(-99 to 99)	Sets the correction curve of the G black gamma.
	B BLACK GAMMA	(-99 to 99)	Sets the correction curve of the B black gamma.
	OUTPUT SELECT ^{a)}	Y/R/G/B	Selects the output signal of VBS/SDI OUT and TEST OUT.

a) For detailed information on OUTPUT SELECT, see a) on page A-16.

Page	Items	Settings	Contents
KNEE	KNEE	OFF/ON	Turns the knee correction circuit on or off.
	KNEE POINT	50 to 109	Sets the knee point level.
	KNEE SLOPE	(-99 to 99)	Set the knee slope level.
	KNEE SATURATION	OFF/ON	Turns the knee saturation function on or off.
	KNEE SAT LEVEL	(-99 to 99)	Sets the knee saturation level.
	WHITE CLIP	OFF/ON	Turns the white clipping function on or off.
	WHITE CLIP LEVEL	100.0 to 109.5	Adjusts the white clipping level.

Page	Items	Setting	Contents
DETAIL 1	DETAIL	OFF/ON	Sets the detail correction function on or off.
	APERTURE	OFF/ON	Turns the aperture correction function on or off.
	DETAIL LEVEL	(-99 to 99)	Sets the general level of the detail signal.
	APERTURE LEVEL	(0 to 15)	Sets the aperture level.
	DETAIL H/V RATIO	(-99 to 99)	Sets the level of the V detail signal.
	CRISPENING	(-99 to 99)	Sets the crispening level.
	LEVEL DEPEND	OFF/ON	Turns the level depend function on or off.
	LEVEL DEPEND LVL	(-99 to 99)	Sets the level of level depend.
	DETAIL FREQ	(-99 to 99)	Sets the frequency of the H detail signal.

Page	Items	Setting	Contents
DETAIL 2	KNEE APERTURE	OFF/ON	Turns the knee aperture function on or off.
	KNEE APT LEVEL	(0 to 199)	Sets the knee aperture level.
	DETAIL WHT LIMIT	(-99 to 99)	Sets the detail white limiter.
	DETAIL BLK LIMIT	(-99 to 99)	Sets the detail black limiter.
	DETAIL V-BLK LMT	(-99 to 99)	Sets the V detail black limiter.

Page	Items	Setting	Contents
SD DETAIL	SD DETAIL	OFF/ON	Turns the detail function on or off.
	SD DETAIL LEVEL	(-99 to 99)	Turns the general level of the detail signal.
	SD CRISPENING	(0 to 15)	Sets the crispening level.
	SD DTL WHT LIMIT	(-99 to 99)	Sets the detail white limiter.
	SD DTL BLK LIMIT	(-99 to 99)	Sets the detail black limiter.
	SD LEVEL DEPEND	OFF/ON	Turns the level depend function on or off.
	SD LV DEPEND LVL	(0 to 15)	Sets the level depend level.
	SD DTL FREQ.	(0 to 3)	Sets the frequency of the H detail signal.
	SD DTL H/V RATIO	(0 to 7)	Sets the V detail.
	SD CROSS COLOR ^{a)}	(0 to 15)	Sets the cross color suppression level.

a) Only for a camcorder which operates with the 59.94I format

Page	Items	Setting	Contents
SKIN DETAIL	SKIN DETAIL ALL	OFF/ON	Turns on all of 1, 2 and 3 of the skin detail setting.
	SKIN DETECT		Executes auto hue detection function.
	SKIN AREA IND	OFF/ON	Turns the zebra indication on or off in the area of the currently selected type of the skin detail setting.
	SKIN DTL SELECT	1/2/3	Selects one of three skin detail settings, which you want to set. The settings of the following items belong to the setting number selected in this item.
	SKIN DETAIL	OFF/ON	Turns the skin detail function on or off.
	SKIN DETAIL LVL	(-99 to 99)	Sets the level of the skin detail signal.
	SKIN DTL SAT.	(-99 to 99)	Adjusts the saturation level of the hue.
	SKIN DTL HUE	0 to 359	Adjusts the center phase of the hue.
	SKIN DTL WIDTH	0 to 359	Adjusts the width of the hue.

Page	Items	Setting	Contents
MTX LINEAR	MATRIX	OFF/ON	Turns the linear matrix correction and user-set matrix correction functions on or off.
	MATRIX (USER)	OFF/ON	Turns the user-set matrix correction function on or off.
	MATRIX (PRESET)	OFF/ON	Turns the preset matrix on or off.
	MATRIX (PRST) SEL	1/2/3/4/5/6	Select the preset matrix.
	MATRIX (USER) R-G	(-99 to 99)	Sets the arbitrary R-G user-set matrix coefficients.
	MATRIX (USER) R-B	(-99 to 99)	Sets the arbitrary R-B user-set matrix coefficients.
	MATRIX (USER) G-R	(-99 to 99)	Sets the arbitrary G-R user-set matrix coefficients.
	MATRIX (USER) G-B	(-99 to 99)	Sets the arbitrary G-B user-set matrix coefficients.
	MATRIX (USER) B-R	(-99 to 99)	Sets the arbitrary B-R user-set matrix coefficients.
	MATRIX (USER) B-G	(-99 to 99)	Sets the arbitrary B-G user-set matrix coefficients.

Page	Items	Setting	Contents
MTX MULTI	MATRIX	OFF/ON	Turns the linear matrix correction and multi matrix correction functions on or off.
	MATRIX (MULTI)	OFF/ON	Turns the multi matrix correction function on or off.
	MATRIX AREA IND	OFF/ON	Turns the zebra indication on or off in the area corresponding to the currently selected setting.
	MATRIX COLOR DET		Executes the automatic color detection function.
	MTX (MULTI)AXIS	B/B+/MG-/MG/MG+/R/R+/YL-/YL/YL+/G-/G/G+/CY/CY+/B-	Sets the region in which the multi matrix correction function can be changed. (sixteen-axis mode)
	MTX (MULTI) HUE	(-99 to 99)	Adjusts the color phase affected by the multi matrix correction function in every sixteen-axis mode.
	MTX (MULTI) SAT	(-99 to 99)	Adjusts the saturation level affected by the multi matrix correction function in every sixteen-axis mode.

Page	Items	Setting	Contents
V MODULATION	V MOD	OFF/ON	Turns the V modulation function on or off.
	MASTER V MOD	(-99 to 99)	Turns the master V modulation function on or off.
	R V MOD	(-99 to 99)	Turns the R V modulation function on or off.
	G V MOD	(-99 to 99)	Turns the G V modulation function on or off.
	B V MOD	(-99 to 99)	Turns the B V modulation function on or off.
	OUTPUT SELECT ^{a)}	Y/R/G/B	Selects the output signal of VBS/SDI OUT and TEST OUT.

a) For detailed information on OUTPUT SELECT, see a) on page A-16.

Page	Items	Setting	Contents
LOW KEY SAT.	LOW KEY SAT.	OFF/ON	Turns the low key saturation function on or off.
	L.KEY.SAT. LEVEL	(-99 to 99)	Sets the saturation level of the low luminance part.
	L.KEY.SAT. RANGE	LOW/L.MID/ H.MID/HIGH	Sets the luminance level at which the low key saturation function becomes effective.
	Y BLACK GAMMA	OFF/ON	Turns the Y black gamma function on or off.
	Y BLK GAM LEVEL	(-99 to 99)	Sets the gamma curve in the low luminance part.
	Y BLK GAM RANGE	LOW/L.MID/ H.MID/HIGH	Sets the luminance level at which the Y black gamma becomes effective.

A

Page	Items	Contents
SCENE FILE	1	Recalls the scene file saved in the memory of the camcorder.
	2	
	3	
	4	
	5	
	STANDARD	Clears all current detail-adjusted settings and switch settings and returns the settings to the standard settings saved in the reference file.
	SCENE RECALL	Recalls the scene file from the memory of the camcorder or the memory stick.
	SCENE STORE	Stores the scene file in the memory of the camcorder or the memory stick.
F.ID	16 characters	

A

MAINTENANCE Menu List

Page	Items	Setting
WHT SHADING	SHADING CH SEL	R/G/B / TEST
	OUTPUT SELECT ^{a)}	Y/R/G/B
	R/G/B WHITE H SAW	(-99 to 99)
	R/G/B WHITE H PARA	(-99 to 99)
	R/G/B WHITE V SAW	(-99 to 99)
	R/G/B WHITE V PARA	(-99 to 99)
	WHITE SAW/PARA	OFF/ON
BLK SHADING	SHADING CH SEL	R/G/B / TEST
	OUTPUT SELECT ^{a)}	Y/R/G/B
	R/G/B BLACK H SAW	(-99 to 99)
	R/G/B BLACK H PARA	(-99 to 99)
	R/G/B BLACK V SAW	(-99 to 99)
	R/G/B BLACK V PARA	(-99 to 99)
	BLACK SAW/PARA	OFF/ON
	MASTER BLACK	(-99 to 99)
MASTER GAIN(TMP)	-3/0/3/6/9/12/18/24/30/ 36/42 dB	
LEVEL ADJ	Y LEVEL	(-99 to 99)
	SYNC LEVEL	(-99 to 99)
	Pr LEVEL	(-99 to 99)
	Pb LEVEL	(-99 to 99)
	TEST SAW	OFF/ANALOG/DIGITAL
	OUTPUT SELECT ^{a)}	Y/R/G/B

a) For detailed information on OUTPUT SELECT, see a) on page A-16.

Page	Items	Setting
SD LEVEL ADJ	SD VBS LEVEL	(-99 to 99)
	SD VBS SETUP LVL	0 %/7.5 % ^{a)}
	SD VF Y LEVEL	(-99 to 99)
	SD VF R-Y LEVEL	(-99 to 99)
	SD VF B-Y LEVEL	(-99 to 99)
BATTERY	BEFORE END 1	5/10/15%
	END 1	0/1/2/3/4/5%
	BEFORE END 2	11.0 to 13.0V
	END 2	10.5 to 11.5V
	BEFORE END 3	11.0 to 13.0V
	END 3	10.5 to 11.5V
VTR MODE-1	VIDEO OUT (F/R)	EE/PB
	AUDIO OUT(F/R)	CUE/EE
	REC AUDIO OUT	EE/SAVE
	CAMERA ADAPTER	ENBLE/DISABLE
	AUDIO CH3/4 MODE	CH1/2 or SW
	REAR XLR AUTO	OFF/ON
VTR MODE-2	AU REC EMPHASYS	OFF/ON
	CUE REC	OFF/ON
	AU REF LEVEL	-18 dB/-20 dB
	AU REF OUT	0 dB/+4 dB/-3 dB
	AU SG (1KHz)	ON/OFF/AUTO
	MIC CH1 VR SEL	SIDE 1/FRONT/F + S1
	MIC CH2 VR SEL	SIDE 2/FRONT/F + S2
	REAR1/WRR LEVEL	SIDE 1/FRONT/F + S1
REAR2/WRR LEVEL	SIDE 2/FRONT/F + S2	

a) Only for a camcorder which operates with the 59.94I format

Page	Items	Setting
VTR MODE-3	TC OUT	AUTO/GENE
	DF/NDF ^{a)}	DF/NDF
	EXT-LK DF/NDF ^{a)}	INT/EXT
	EXT-LK UBIT	INT/EXT
	LTC UBIT	FIX/TIME
	VITC UBIT	FIX/TIME
	WATCH AUTO ADJ	OFF/ON
	UBIT GROUP ID	000/101
VTR MODE-4	REC TALLY BLINK	OFF/ON
	REC START STOP	OFF/ON
	MODE SELECT	SEL/OFF/CONT
	TIMER SET	1H/3H/8H
	STABY OFF TIMER	OFF/5MIN/10MIN/ 30MIN/60MIN
	STOP KEY FREEZE	DSABL/FRAME/FIELD
VTR MODE-5	LTC UB-MARKER	SET/ALL/OFF
	REC START MARK	OFF/ON
	SHOT MARKER 1	OFF/ON
	SHOT MARKER 2	OFF/ON
	SHOT TIME DISP	MD:HM/DM:HM/D:HMS
PRESET WHT	COLOR TEMP. <P>	3200
	COLOR FINE <P>	(-99 to 99)
	R GAIN <P>	(-99 to 99)
	B GAIN <P>	(-99 to 99)
	AWB ENABLE <P>	OFF/ON

a) Only for a camcorder which operates with the 59.94I format

Page	Items	Setting
DCC ADJUST	DCC FUNCTION SEL	DCC/AdaptiveKNEE/FIX
	DCC RANGE	400/450/500/550/600%
	DCC POINT	(-99 to 99)
	DCC GAIN	(-99 to 99)
	DCC PEAK FILTER	0 to 3
	DCC DELAY TIME	(-99 to 99)
AUTO IRIS 2	IRIS WINDOW	1/2/3/4/5/6/Variable
	IRIS WINDOW IND.	OFF/ON
	IRIS LEVEL	(-99 to 99)
	IRIS APL RATIO	(-99 to 99)
	IRIS VAR WIDTH	20 to 479
	IRIS VAR HEIGHT	20 to 269
	IRIS VAR H POS	(-480 to 479)
	IRIS VAR V POS	(-270 to 269)
	IRIS SPEED	0/1/2/3/4/5
	CLIP HIGH LIGHT	OFF/ON
FUNCTION 3	WHT FILTER INH	OFF/ON
	COLOR BAR SEL	SMPTE/100%/75%/ SMPTE(4:3)/100%(4:3)/ 75%(4:3)
	RM COMMON MEMORY	OFF/ON
	VTR START/STOP	RM/CAM/PARA
GENLOCK	GENLOCK	OFF/ON
	RETURN VIDEO	OFF/ON
	GL H PHASE COASE	(-99 to 99)
	GL H PHASE FINE	(-99 to 99)

Page	Items	Setting
ND COMP	ND OFFSET ADJUST	OFF/ON
	CLEAR ND OFFSET	EXEC
FORMAT	CURRENT	Displays the curent format.
	NEXT	59.94i/50i ^{a)} 50i/25P ^{b)}

a) For an HDW-730

b) For an HDW-750P

Detailed information on items related to the VTR section on the MAINTENANCE menu

In this section, detailed information on items in the MAINTENANCE menu related to the VTR section are described.

Page	Items	Setting	Contents
A	BEFORE END 1	5/10/15%	Used when a BP-M50/ M100 Battery Pack is used. Sets the voltage warning level just before the battery ends.
	END 1	0/1/2/3/4/ 5%	Used when a BP-M50/ M100 Battery Pack is used. Sets the voltage level at which the battery ends and the camcorder stops operation, just before the battery ends.
	BEFORE END 2	11.0 to 13.0V(in 0.1V steps)	Used when a BP-L60A Battery Pack is used. Sets the voltage warning level just before the battery ends.
	END 2	10.5 to 11.5 V(in 0.1V steps)	Used when a BP-L60A Battery Pack is used. Sets the voltage level at which the battery ends and the camcorder stops operation, just before the battery ends.

Page	Items	Setting	Contents
BATTERY (Continued)	BEFORE END 3	11.0 to 13.0V (in 0.1V steps)	Used when a battery pack other than a BP-M50/M100/L60A or an external power connected to the DC IN connector is used. Sets the voltage warning level just before the battery ends.
	END3	10.5 to 11.5 V (in 0.1V steps)	Used when a battery pack other than a BP-M50/M100/L60A or an external power connected to the DC IN connector is used. Sets the voltage level at which the battery ends and the camcorder stops operation, just before the battery ends.
VTR MODE-1	VIDEO (F/R) OUT (FF/REW)	EE/PB	Selects the video output signal during FF/REW.
	AUDIO (F/R) OUT (FF/REW)	CUE/EE	Selects the audio output signal during FF/REW.
	REC AUDIO OUT	EE/SAVE	Selects the audio output signal during recording.
	CAMERA ADAPTOR	ENABL/ DSABL	Selects whether the camera adaptor is enabled to use or not enabled. ENABL: Camera adaptor can be used. DSABL: Camera adaptor cannot be used.

Page	Items	Setting	Contents
VTR MODE-1 (Continued)	AUDIO MODE	CH1/2/ SW	Selects the sources to be recorded to channels CH-3/4. CH1/2: Same sources as CH-1/2. SW: Signals selected by the AUDIO IN CH-3/CH-4 switches.
	REAR XLR AUTO	OFF/ON	Turns the XLR connection automatic detection on or off .
VTR MODE-2	AU REC EMPHASIS	OFF/ON	Turns the audio emphasis during recording on or off.
	CUE REC	OFF/ON	Turns recording the input signal in a cue track on or off.
	AU REF LEVEL	-18dB/ -20dB	Sets the reference level (Head Room).
	AU REC OUT	0dB/+4dB/ -3dB	Sets the output reference level.
	AU SG (1kHz)	ON/OFF/ AUTO	Sets whether to output a 1 kHz test tone during the Color Bar mode or not. ON: a 1 kHz test tone is output during the Color Bar mode. OFF: a 1 kHz test tone is not output during the Color Bar mode. AUTO: a 1 kHz test tone is output only when the CH 1 AUDIO SELECT switch on the inside panel is in the AUTO position.

Page	Items	Setting	Contents
VTR MODE-2 (Continued)	MIC CH1 LEVEL	SIDE1/ FRONT/ F+S1	<p>When recording the front microphone sound on CH 1, selects which control knob is to be used for the level adjustment.</p> <p>SIDE 1: Adjust it with the LEVEL knob (left side) on the side panel.</p> <p>FRONT: Adjust it with the MIC LEVEL knob on the front panel.</p> <p>F + S1: It can be adjusted using either the LEVEL knob (left side) or the MIC LEVEL knob. (The two knobs are linked to each other.)</p>
	MIC CH2 LEVEL	SIDE2/ FRONT/ F+S2	<p>When recording the front microphone sound on CH 2, selects which control knob is to be used for the level adjustment.</p> <p>SIDE 2: Adjust it with the LEVEL knob (right side) on the side panel.</p> <p>FRONT: Adjust it with the MIC LEVEL knob on the front panel.</p> <p>F + S2: It can be adjusted using either the LEVEL knob (right side) or the MIC LEVEL knob. (The two knobs are linked to each other.)</p>

Page	Items	Setting	Contents
VTR MODE-2 (Continued)	REAR1/WRR LEVEL	SIDE1/ FRONT/ F+S1	<p>Selects any of these knobs to adjust the audio level of the equipment that is connected to the wireless microphone and whatever is connected to the AUDIO IN CH-1 connector on the rear panel.</p> <p>SIDE 1: Adjust it with the LEVEL knob (left side) on the side panel.</p> <p>FRONT: Adjust it with the MIC LEVEL knob on the front panel.</p> <p>F + S1: It can be adjusted using either the LEVEL knob (left side) or the MIC LEVEL knob. (The two knobs are linked to each other.)</p>

Page	Items	Setting	Contents
VTR MODE-2 (Continued)	REAR2/WRR LEVEL	SIDE2/ FRONT/ F+S2	<p>Selects any of these knobs to adjust the audio level of the equipment that is connected to the wireless microphone and whatever is connected to the AUDIO IN CH-2 connector on the rear panel.</p> <p>SIDE 2: Adjust it with the LEVEL knob (right side) on the side panel.</p> <p>FRONT: Adjust it with the MIC LEVEL knob on the front panel.</p> <p>F + S2: It can be adjusted using either the LEVEL knob (right side) or the MIC LEVEL knob. (The two knobs are linked to each other.)</p>
VTR MODE-3	TC OUT	AUTO/ GENE	<p>Selects the time code signal output.</p> <p>AUTO: Outputs the time code generator output during recording and outputs the time code reader output during playback.</p> <p>GENE: Outputs the time code generator output during recording and playback.</p>

Page	Items	Setting	Contents
VTR MODE-3 (Continued)	DF/NDF ^{a)}	DF/NDF	Sets DF or NDF mode. DF: Drop frame mode NDF: Non drop frame mode
	EXT-LK DF/ NDF ^{a)}	INT/EXT	Selects either internal setting or external setting for DF/ NDF. INT: Internal EXT: External
	EXT-LK UBIT	INT/EXT	Sets whether the LTC UBIT setup value locks to an INT or an EXT source when the time code is locked to an external source. INT: Internal lock EXT: External lock
	LTC UBIT	FIX/ TIME	Sets the data to be recorded in UBIT of LTC. FIX: Records the data that is set by the user. TIME: Records the present time.
	VITC UBIT	FIX/ TIME	Sets the data to be recorded in UBIT of VITC. FIX: Records the data that is set by the user. TIME: Records the present time.

a) Only for a camcorder which operates with the 59.94I format

Page	Items	Setting	Contents
VTR MODE-3 (Continued)	WATCH AUTO ADJ	OFF/ON	Matches the time of the built-in clock with the time data of the user bits of an external time code. Turns the automatic time correction function of the built-in clock on or off .
	UBIT GROUP ID	000/101	Selects the UBIT GROUP ID.
VTR MODE-4	REC TALLY BLINK	OFF/ON	Turns the tally illumination control on or off in the event of BATTERY BEFORE END/ TAPE BEFORE END.
	REC START/ STOP	OFF/ON	Turns on or off the alarm sound at REC START/ STOP.
	MODE SELECT	SEL/ OFF/ CONT	Sets the time code (TC) display after power-off as follows. SEL: The TC display turns off after the elapse of the time set by the TIMER SET below. OFF: Not displayed. CONT: Displayed.

Page	Items	Setting	Contents
VTR MODE-4 (Continued)	TIMER SET	1H/3H/ 8H	Sets the duration of time after which the TC display is to be turned off after power-off, when the MODE SELECT item, above, is set to SEL (H: hours).
	STBY OFF TIMER	OFF/ 5MIN/ 10MIN/ 30MIN/ 60MIN	Sets the length of time for the stand-by off timer.
	STOP KEY FREEZE	OFF/ FRAME/ FIELD	Selects the freeze function.

A

Page	Items	Setting	Contents
VTR MODE-5	LTC UB-MARKER	SET/ALL/ OFF	<p>Sets whether to write the marker in UBIT of LTC or not.</p> <p>SET: Whether to write the marker or not is determined by the ON/OFF setting of the following items REC START MARK, SHOT MARKER 1 and SHOT MARKER 2, as described below.</p> <p>ALL: REC START MARK, SHOT MARKER 1 and SHOT MARKER 2 are all written.</p> <p>OFF: None are written.</p>
	REC START MARK	OFF/ON	Turns REC START MARK on or off.
	SHOT MARKER 1	OFF/ON	Turns SHOT MARKER 1 on or off.
	SHOT MARKER 2	OFF/ON	Turns SHOT MAKER 2 on or off.
	SHOT TIME DISP	MD:HM/ DM:HM/ D:HMS	<p>Sets the format of the time to be displayed on the LCD.</p> <p>MD:HM: Month, day, hour, minute.</p> <p>DM:HM: Day, month, hour, minute.</p> <p>D:HMS: Day, hour, minute, second.</p>

FILE Menu List

Page	Items	Setting
USER FILE	USER FILE LOAD	
	USER FILE SAVE	
	F. ID	16 characters
	USER PRESET	
USER FILE2	STORE USR PRESET	
	CLEAR USR PRESET	
	CUSTOMIZE RESET	
	LOAD CUSTOM DATA	OFF/ON
	LOAD OUT OF USER	OFF/ON
	BEFORE FILE PAGE	OFF/ON
	USER LOAD WHITE	OFF/ON
ALL FILE	ALL FILE LOAD	
	ALL FILE SAVE	
	F. ID	16 characters
	ALL PRESET	
	STORE ALL PRESET	
	CLEAR ALL PRESET	
	3SEC CLR PRESET	OFF/ON
SCENE FILE	1	
	2	
	3	
	4	
	5	
	STANDARD	
	SCENE RECALL	
	SCENE STORE	
	F. ID	16 characters

Page	Items	Setting
REFERENCE	REFERENCE STORE	
	REFERENCE CLEAR	
	REFERENCE LOAD	
	REFERENCE SAVE	
	F. ID	16 characters
	SCENE WHITE DATA	OFF
LENS FILE 1	LENS FILE RECALL	
	LENS FILE STORE	
	F. ID	16 characters
	LENS NO OFFSET	
	SOURCE MEMORY	
LENS FILE 2	LENS M VMOD	(-99 to 99)
	LENS CENTER H	-480 to 479
	LENS CENTER V	-270 to 269
	OUTPUT SELECT ^{a)}	Y/R/G/B
	LENS R FLARE	(-99 to 99)
	LENS G FLARE	(-99 to 99)
	LENS B FLARE	(-99 to 99)

a) For detailed information on OUTPUT SELECT, see a) on page A-16.

Page	Items	Setting
LENS FILE 3	SHADING CH SEL	R/G/B
	OUTPUT SELECT ^{a)}	Y/R/G/B
	LENS RGB H SAW	(-99 to 99)
	LENS RGB H PARA	(-99 to 99)
	LENS RGB V SAW	(-99 to 99)
	LENS RGB V PARA	(-99 to 99)
MEMORY STICK	FORMAT	
	MS IN > JUMP TO	OFF/USER/ALL/ SCENE/LENS/REFER
TELE FILE	TELEFILE CLEAR	

a) For detailed information on OUTPUT SELECT, see a) on page A-16.

A

DIAGNOSIS Menu List

Page	Itmes
HOURS METER	RESET METER
	DRUM RUNNING
	TAPE RUNNING
	OPERATION
	THREADING
	DRUM RUNNING - 2
	TAPE RUNNING - 2
	OPERATION - 2
	THREADING - 2
TIME/DATE	ADJUST
	HOUR
	MIN
	SEC
	YEAR
	MONTH
	DAY
ROM VERSION	AT: Ver X.XX
	SS: Ver X.XX
	FP: Ver X.XX
	EQ: Ver X.XX
DEV STATUS	I/O EEPROM LSI
OPTION BOARD	DOWN CONVERTER
	HD - SDI OUTPUT
	PICTURE CHACHE

About a “Memory Stick”

What is “Memory Stick”?

“Memory Stick” is a new compact, portable and versatile IC (Integrated Circuit) recording medium with a data capacity that exceeds a floppy disk. “Memory Stick” is specially designed for exchanging and sharing digital data among “Memory Stick” compatible products. Because it is removable, “Memory Stick” can also be used for external data storage. “Memory Stick” is available in two sizes: standard size and compact “Memory Stick Duo” size. Once attached to a Memory Stick Duo adapter, “Memory Stick Duo” turns to the same size as standard “Memory Stick” and thus can be used with products compliant with standard “Memory Stick.”

Types of “Memory Stick”

“Memory Stick” is available in the following four types to meet various requirements in functions.

- **“Memory Stick-R”**

Stored data are not overwritten. You can write data to “Memory Stick-R” with “Memory Stick-R” compatible products only. Copyright protected data that requires MagicGate copyright protection technology cannot be written to “Memory Stick-R.”

- **“Memory Stick”**

Stores any type of data except copyright-protected data that requires the MagicGate copyright protection technology.

- **“MagicGate Memory Stick”**

Equipped with the MagicGate copyright protection technology.

- **“Memory Stick-ROM”**

Stores pre-recorded, read-only data. You cannot record on “Memory Stick-ROM” or erase the pre-recorded data.

Available types of “Memory Stick”

You can use a “Memory Stick” with your product.

Note

You can not use a “Memory Stick Duo” with your product.

Note on data read/write speed

Data read/write speed may vary depending on the combination of the “Memory Stick” and “Memory Stick” compliant product you use.

What is MagicGate ?

MagicGate is copyright protection technology that uses encryption technology.

Before using a “Memory Stick”

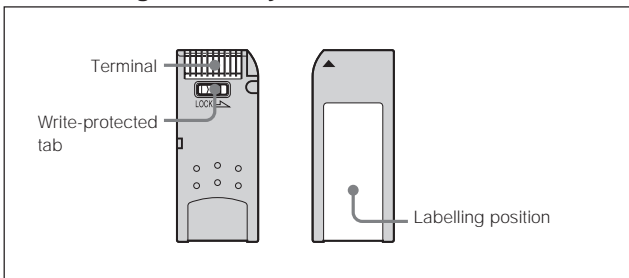

- When you set the “Memory Stick” erasure prevention switch to “LOCK,” data cannot be recorded, edited, or erased.
- Data may be damaged if:
 - You remove the “Memory Stick” or turn off the unit while it is reading or writing data.
 - You use the “Memory Stick” in a location subject to the effects of static electricity or electric noise.
- We recommend that you make a backup copy of important data that you record on the “Memory Stick.”

Notes

- Do not attach anything other than the supplied label to the “Memory Stick” labeling position.

-
- Attach the label so that it does not stick out beyond the labeling position.
 - Carry and store the “Memory Stick” in its case.
 - Do not touch the connector of the “Memory Stick” with anything, including your finger or metallic objects.
 - Do not strike, bend, or drop the “Memory Stick.”
 - Do not disassemble or modify the “Memory Stick.”
 - Do not allow the “Memory Stick” to get wet.
 - Do not use or store the “Memory Stick” in a location that is:
 - Extremely hot, such as in a car parked in the sun
 - Under direct sunlight
 - Very humid or subject to corrosive substances

ACCESS Indicator

A If the ACCESS indicator is turned on or is flashing, data is being read from or written to the “Memory Stick.” At this time, do not shake the computer or product or subject them to shock. Do not turn off the power of the computer and product or remove the “Memory Stick.” This may damage the data.

Precautions

- To prevent data loss, make backups of data frequently. In no event will Sony be liable for any loss of data.
- Unauthorized recording may be contrary to the provisions of copyright law. When you use a “Memory Stick” that has been pre-recorded, be sure that the material has been recorded in accordance with copyright and other applicable laws.
- The “Memory Stick” application software may be modified or changed by Sony without prior notice.
Note that there are certain restrictions on recording stage performances and other entertainment events, even if they are recorded for personal use only.

“Memory Stick” and  are trademarks of Sony Corporation.

Index

A

AC-550/550CE AC Adaptor 1-8, 2-1, 5-1, 5-5

AC-DN2B AC Adaptor 1-8, 2-1, 5-1, 5-6

Accessory attachments 2-3

AC power supply 1-8, 5-5

Adjusting the flange focal length 5-15

Adjustments and settings for recording

- assigning the functions to the ASSIGN 1/2 switches 4-109

- audio level 4-28

- black balance and white balance 4-1

- electronic shutter 4-12

- memory stick operations 4-118

- menu display on the viewfinder screen 4-46

- selecting the output signals 4-101

- setting the color temperature 4-104

- setting the date/time of the internal clock 4-114

- Setting the stand-by off timer during rec-pause 3-66

- specifying an offset for the auto white balance setting 4-106

- status display on the viewfinder screen 4-64

- time data 4-35

ADVANCE button 2-36

ALARM volume control 2-9

Aliasing 6-17

ALL menu 4-46

Anton Bauer Ultralight System 5-6

ASSIGN switches 2-20, 4-109

Attaching a UHF portable tuner 5-24

Audio

- audio functions 2-5

- audio level adjustment 4-28

- audio level indicator 4-67

- level meter 2-42, 4-30

- line input 5-28

- testing the audio

- functions 6-7

AUDIO IN switches 2-7

AUDIO IN CH-1/CH-2 connectors and LINE/MIC/+48 V ON switches 2-8

AUDIO IN CH-1/CH-2 / CH-3/ CH-4 switches 2-7

AUDIO OUT connector 2-8

AUDIO SELECT switches 2-7

Auto Interval Rec function 3-29

Automatic iris adjustment 4-21

AUTO W/B BAL switch 2-20

B

BACK TALLY switch 2-41

BACK TALLY indicator 2-40

Battery (See also Power supply.)

- Anton Bauer Ultralight System 5-6

-
- Avoiding breaks in operation due to dead batteries 5-4
 - BATT indicator 2-47, 3-7, 6-1, 6-14
 - Battery attachment 2-1
 - Battery status indicator 2-47, 6-14
 - BC-L120/M50 Battery Charger 1-8, 5-1, A-6
 - Hunting 4-9
 - Using the BP-L60A/M50/M100 Battery Pack 1-8, 2-1, 5-1, 5-26
 - BC-L120 1-8, 5-1, A-6
 - BCT-HD12CL 6-11, A-8
 - BKW-401 1-8, 5-11, A-7
 - Black balance
 - adjusting 4-2
 - error message 4-4
 - memory 4-5
 - BP-L60A/M50/M100 1-8, 2-1, 5-1, 5-26, A-6
 - BRIGHT control 2-15
 - Built-in speaker 2-12
-
- C
- C-74 1-9, A-7
 - CAC-12 Microphone Holder 1-8, 5-22
 - CAC-12 1-8, 5-22, A-7
 - Camera section
 - features 1-1
 - specifications A-2
 - testing 6-2
 - Camera synchronization
 - camera synchronization 4-44
 - changing to an external power supply 4-44
 - connection example 4-40
 - procedure 4-42
 - releasing time code
 - synchronization 4-44
 - setting the user bits 4-43
 - Cameraman tally indicator 2-17
 - CANCEL/PRST / ESCAPE switch 2-32
 - Cassette tape
 - loading 3-1
 - preventing accidental erasure 3-5
 - slack checking 3-3
 - unloading 3-3
 - usable cassettes A-6
 - CC filter 2-18, 4-7
 - Center marker 2-16
 - Cleaning
 - BCT-HD12CL cleaning
 - cassette 6-11, A-8
 - video heads 6-11
 - viewfinder 6-11
 - Color playback 3-56
 - Condensation 6-2
 - Continuous recording
 - continuous recording 3-12
 - continuous recording on previous cut (RE-TAKE function) 3-52

Continuous trigger mode in Manual Interval Rec mode 3-44
CONTRAST control 2-15
CRS-3P Cradle Suspension 5-20, A-7
CTL 2-36
CUE IN switch 2-8

D

DATA DISPLAY switch 2-38
DCC function 2-21
DC IN connector 2-1
DC OUT connector 2-8
DIAGNOSIS menu 4-46, A-39
Diopter adjustment ring 2-16
Display panel
 tape status, battery status, and level indicators 2-42
 status and warning indicators 2-43, 6-14
 time code displays 2-44
DISPLAY switch 2-36
DISPLAY (LCD) switch 2-36
DISPLAY/ASPECT switch 2-40
Drop frame/non-drop frame mode 4-37

E

Earphone checking 6-7
EARPHONE jacks 2-13
ECS mode 4-12, 4-17
E-E sound 2-12
EJECT button 2-27

Electronic shutter
 See Shutter.
End Search function 3-53
Equipment setup
 adjusting the flange focal length 5-15
 adjusting the shoulder pad position 5-33
 adjusting the viewfinder 5-7
 attaching the shoulder strap 5-31
 audio input system 5-17
 connecting the remote control unit 5-36
 mounting the lens 5-14
 power supply 5-1
 putting on the rain cover 5-34
 storing the camcorder in the carrying case 5-7
 tripod mounting 5-29
Error messages
 adjusting the black balance 4-4
 adjusting the white balance 4-10
 memory stick operations 4-126, 4-129
EVS mode 4-13
Extended Clear Scan mode
 See ECS mode.
Extender indicator 4-65
Extension board 1-8, A-8
External microphone
 testing 6-8
 use 5-19

External time code 4-40
Eyecup 2-14, 6-12
Eypiece
 detaching 5-12
 refitting 5-13

F

F-stop indicator 4-66
F FWD button and indicator 2-27
FILE menu 4-46, A-36
Filter
 CC filter 2-18, 4-7
 filter indicator 4-68
 fog-proof filter 6-13
 ND filter 2-18, 4-7
 protecting filter 6-12
 selecting 2-19, 4-7
FILTER selector 2-18
Flicker 4-13
F-RUN/SET/R-RUN switch 2-37
 free run/recording run
 switch 2-37, 4-36, 4-39
Fog-proof filter 1-8, 6-13, A-7

G

Gain
 gain indicator 4-68
 setting the GAIN selector
 values 4-98
GAIN selector 2-20
GENLOCK IN connector 2-25,
2-33
Good shot marker 3-15

H

HD SDI OUT connector 2-24
HDCA-901 2-8, A-7
HDVF-20A A-6
Head cleaning 6-11
HKDW-702 1-8, 2-23, 2-24, 3-57,
4-101
HKDW-703 1-8, 3-20, 3-28
HKDW-704 1-8, 4-90
HOLD button 2-36
HUMID indicator 2-43, 3-7, 6-1,
6-14

I, J, K

Internal clock setting 4-114
Interval recording
 Auto Interval Rec mode 3-29
 Manual Interval Rec mode
 3-40
Iris setting indicator 4-66

L

Lens
 lens mount securing rubber
 5-14
 locking lever 2-4
 mounting 5-14
 mount 2-4
 mount cap 2-4
LENS connector 2-4
LEVEL controls 2-7
LIGHT connector 2-4
Light shoe 2-3
LIGHT switch 2-2, 2-41

Line input (audio) 5-28
LOCK ring 2-17
Loop Rec function 3-20
LTC 1-4, 4-39

M

Maintenance

video head cleaning 6-11
viewfinder cleaning 6-11

MAINTENANCE menu 4-46,
A-31

Manual Interval Rec mode

continuous trigger mode 3-45
single trigger mode 3-40

Memory stick

compartment 2-30
handling 4-118

Menu list

DIAGNOSIS menu list A-39
FILE menu list A-36
MAINTENANCE menu list
A-31
OPERATION menu list A-9
PAINT menu list A-19

Microphone

supplied microphone 2-5
using an external
microphone 5-20
using the supplied
microphone 5-17

Microphone level adjustment

external microphone 4-28
front microphone 4-31

Microphone holder 5-21

MENU knob 2-31

MENU ON/OFF switch 2-32

MIC IN connector 2-5

MIC LEVEL knob 2-5

MLB-1M-100 3-58, A-6

MONITOR volume control 2-10

MONITOR switch /CH-1/2 /CH-3/
4 switch

CH-1/2 /CH-3/4 switch 2-10

MONITOR switch 2-11

N

ND filter 2-18, 4-7

Notes on CCD image sensors 6-17

O

OPERATION menu 4-47, A-9

OUTPUT/DCC selector 2-21

P, Q

PAINT menu 4-47, A-19

PEAKING control 2-15

Playback

checking the recording 3-55
color playback 3-56
freezing a picture during
playback 3-63
parts and controls 2-14
recording review 3-55
using a color video monitor
3-56

PLAY button and indicator 2-28

POWER switch 2-2

Power supply (See also Battery.)

- Anton Bauer Ultralight System 5-6
- dead battery 5-4
- power supply 2-1
- using the AC-550/550CE AC adaptor 1-8, 5-5
- using the AC-DN2B AC adaptor 1-8, 5-6
- using the BP-L60A Battery Pack 1-8, 5-1

Precautions 1-7

PRESET/REGEN/CLOCK

switch 2-37

Protecting filter 6-12

Putting on the rain cover 5-34

R

Real time 4-37, 4-114

REAR TALLY switch 2-41

Recording

- basic procedure 3-6
- cassette tape 3-1, A-6
- checking the recording 3-55
- continuous recording 3-12
- continuous recording on previous cut (RE-TAKE function) 3-52
- interval recording 3-28
- recording start marker 3-20
- recording start time code 3-58
- searching for the last recorded portion (End search function) 3-53

shooting pictures at intervals (Interval Rec function) 3-28, 3-40

shooting and recording/
playback functions 2-14

starting a shoot with a few seconds of pre-stored picture (Loop Rec function) 3-20

superimposed shot data 4-81

Recording review 3-55

Recording run

See F-RUN/SET/R-RUN switch.

Reference video signal 4-40

REMOTE connector 2-24

Remote control

connecting a remote control unit 5-36

RM-B150 Remote Control Unit 1-8, 2-24, 5-36, 5-38, A-7

RESET button 2-36

RE-TAKE function 3-52

REW button and indicator 2-27

RF indicator 2-43, 6-14

RM-B150 1-8, 2-24, 5-36, 5-38, A-7

S

Safety zone marker 2-16

SCENE file

loading 4-145

resetting the camcorder setting to the standard setting 4-150

setting the File ID 4-143
storing 4-135

SERVO indicator 2-43, 6-14

SHIFT button 2-36

Shooting
See Recording.

Shot ID 4-84

Shoulder pad
adjusting the position 5-33
feature 2-4

Shoulder strap
attaching the shoulder strap
5-31
shoulder strap posts 2-3

Shutter
changing the range of choice
of shutter mode and speed
settings 4-18
indicator 4-68
ECS mode 4-12, 4-17
EVS mode 4-13
selecting mode and speed
4-14
setting the electronic
shutter 4-12
shutter modes 4-12
standard mode 4-12

SHUTTER selector 2-20

SLACK indicator 2-43, 6-14

Speaker
operation 2-12
testing 6-7

Specifications A-1

STATUS ON/SEL / OFF switch
2-31

Status confirmation window 4-90

STOP button 2-28

Storage precautions 1-7

Supplied accessories A-6

System configuration 1-8

T

TALLY indicator 2-14, 2-40

TALLY switch 2-16, 2-40

TAPE and E indicator 2-42, 6-14

Tape (See also Cassette tape.)
remaining tape indicator 2-42,
4-67, 6-14
testing the tape transport
functions 6-5

TC IN connector 2-34

TC OUT connector 2-34

TEST OUT connector 2-24

Tele-File 3-58

Testing
See Testing the camcorder
before shooting.

Testing the camcorder before
shooting
audio level adjusting
functions 6-7
camera section 6-2
earphone 6-7
external microphones 6-8
front microphone 6-6
iris function 6-4
preparations for testing 6-1
speaker 6-7
tape transport functions 6-5

- time code function 6-10
- user bit functions 6-10
- viewfinder 6-3
- VTR section 6-5
- XLR connection automatic detection function 6-9
- zoom function 6-4

Testing the iris and zoom functions 6-4

Time code

- checking 6-10
- displaying 2-36, 2-44
- free run mode 2-37
- free run/recording run switch 2-37
- preset/regeneration switch 2-37
- resetting 2-36
- setting 4-35
- switch settings and displayed information 2-45
- synchronizing 4-40
- time code system 2-33

Time counter display 2-44

Time data

- displaying 2-44
- resetting 4-36
- setting 4-35

TOP menu 4-46

Tripod

- adaptor 5-29
- mount 2-4
- mounting 5-29

TURBO GAIN button 2-22

U

User bits

- checking 6-10
- displaying 2-45
- memory 4-38
- resetting 4-39
- setting 4-37
- synchronization 4-43

User file

See USER menu setting.

USER menu setting

- data to be saved as a user file 4-125
- loading from the memory stick 4-126
- resetting 4-133
- saving as the user file to the memory stick 4-122
- setting the file ID 4-130

USER MENU CUSTOMIZE

menu 4-46, 4-55

Using the supplied microphone 5-17

V

Vertical smear 6-16

Video

- head cleaning 6-11
- monitor 1-8, 3-56, 3-57

Viewfinder

- adjusting the focus 5-9
- adjusting the position 5-7
- adjusting the screen 5-9
- BATT indicator 2-47

BKW-401 Rotation
Bracket 1-8, 5-11
cleaning 6-11
detaching 5-10
display mode and setting
change and adjustment
progress message 4-73
eyepiece 5-12
front-rear positioning lever
2-16, 5-8
indicators on the viewfinder
2-46
left-right positioning ring
2-16, 5-7
REC indicator 2-46
related equipment A-7
selecting display items 4-70
setting 4-78
status display 4-64
stopper 2-17, 5-10
testing 6-3
VTR SAVE indicator 2-47
VITC 1-4, 4-39
VTR
specifications A-3
testing 6-5
operation and status
indicators 2-43
features 1-4
VTR SAVE/STBY switch 2-27
VTR START button 2-26
VBS/SDI OUT connector 2-23

W

WARNING indicator 2-41, 6-14
Warnings and indications
display panel indications
2-42, 6-14
parts and controls 2-39
status confirmation window
4-90
TALLY indicator 2-40, 6-14
viewfinder screen displays
6-14
warning sound 2-9, 6-14
warning system 6-14

White balance

adjusting 4-6
error messages 4-10
if you have no time to adjust
the white balance 4-11
memory indicator 4-68
memory 4-11

WHITE BAL switch 2-22

WRR-810A/860A/862A/862B 1-8,
5-24, A-7

WRR-855A/855B 1-8, 5-24, A-7

Z

Zebra pattern 2-15

ZEBRA switch 2-15

Zoom

position indicator 4-65
testing 6-4

Name

Office

Address

Phone

The material contained in this manual consists of information that is the property of Sony Corporation and is intended solely for use by the purchasers of the equipment described in this manual. Sony Corporation expressly prohibits the duplication of any portion of this manual or the use thereof for any purpose other than the operation or maintenance of the equipment described in this manual without the express written permission of Sony Corporation.

Sony Corporation

B & P Company

2003.04

©2002

HDW-730/750/750P (SY)

3-620-217-12 (1)

<http://www.sony.net/>