

SONY®

PROFESSIONAL DISC CAMCORDER

PDW-510/510P

PDW-530/530P

XDCAM[™]
Professional Disc System

Professional Disc

MPEG IMX

DVCAM[™]



MEMORY STICK[™]

OPERATION MANUAL
1st Edition (Revised 4)

English

WARNING

To prevent fire or shock hazard, do not expose the unit to rain or moisture.

To avoid electrical shock, do not open the cabinet. Refer servicing to qualified personnel only.

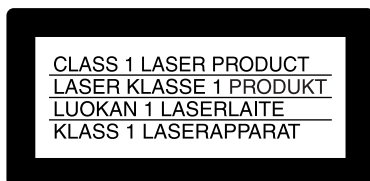

This Professional Disc Camcorder is classified as a CLASS 1 LASER PRODUCT.

Laser diode properties

Wavelength: 403 to 410 nm

Emission duration: Continuous

Laser output power: 65 mW (max. of pulse peak), 35 mW (max. of CW)

Tekniska data för laserdiod

Våglängd: 403 till 410 nm

Emissionslängd: Kontinuerlig

Laserut effekt: 65 mW (max. för pulstopp), 35 mW (max. för kontinuerlig våg)

Spesifikasjoner laserdiode

Bølgelengde: 403 til 410 nm

Strålingens varighet: Kontinuerlig

Laserens effekt: 65 mW (maks stråletpunkt), 35 mW (maks ved kontinuerlig stråling)

Laserdiodin ominaisuudet

Aallon pituus: 403 - 410 nm

Välityksen kesto: Jatkuva

Laserlähdon teho: 65 mW (sykehuipun maks.), 35 mW (jatkuvan aallon maks.)



This label is located inside the outside panel of the unit.

CAUTION

As the laser beam used in this Professional Disc Camcorder is harmful to the eyes, do not attempt to disassemble the cabinet. Refer servicing to qualified personnel only.

CAUTION

The use of optical instruments with this product will increase eye hazard.

CAUTION

Use of controls or adjustments or performance of procedures other than those specified herein may result in hazardous radiation exposure.

VAROITUS!

LAITTEEN KÄYTTÄMINEN MUULLA KUIN TÄSSÄ KÄYTTÖOHJEESSA MAINITULLA TAVALLA SAATTAAL TISTAA KÄYTTÄJÄN TURVALLISUUSLUOKAN 1 YLITTÄVÄLLE NÄKYMÄTTÖMÄLLE LASERSÄTEILYLLE.

VARNING

OM APPARATEN ANVÄNDS PÅ ANNAT SÄTT ÄN I DENNA BRUKSANVISNING SPECIFICERATS, KAN ANVÄNDAREN UTSÄTTAS FÖR OSYNLIG LASERSTRÅLNING, SOM ÖVERSKRIDER GRÄNSEN FÖR LASERKLASS 1.

For the customers in the USA

This equipment has been tested and found to comply with the limits for a Class B digital device, pursuant to Part 15 of the FCC Rules. These limits are designed to provide reasonable protection against harmful interference in a residential installation. This equipment generates, uses, and can radiate

radio frequency energy and, if not installed and used in accordance with the instructions, may cause harmful interference to radio communications. However, there is no guarantee that interference will not occur in a particular installation. If this equipment does cause harmful interference to radio or television reception, which can be determined by turning the equipment off and on, the user is encouraged to try to correct the interference by one or more of the following measures;

- Reorient or relocate the receiving antenna.
- Increase the separation between the equipment and receiver.
- Connect the equipment into an outlet on a circuit different from that to which the receiver is connected.
- Consult the dealer or an experienced radio/TV technician for help.

You are cautioned that any changes or modifications not expressly approved in this manual could void your authority to operate this equipment.

The shielded interface cable recommended in this manual must be used with this equipment in order to comply with the limits for a digital device pursuant to Subpart B of Part 15 of FCC Rules.

For the customers in the USA

This product contains mercury. Disposal of this product may be regulated if sold in the USA. For disposal or recycling information, please contact your local authorities or the Electronics Industries Alliance (www.eiae.org <http://www.eiae.org>).

For the customers in the USA and Canada

• RECYCLING LITHIUM-ION BATTERIES

Lithium-Ion batteries are recyclable. You can help preserve our environment by returning your used rechargeable batteries to the collection and recycling location nearest you.



For more information regarding recycling of rechargeable batteries, call toll free 1-800-822-8837, or visit <http://www.rbrc.org/>

Caution: Do not handle damaged or leaking lithium-ion batteries.

• RECYCLING NICKEL METAL HYDRIDE BATTERIES

Nickel metal hydride batteries are recyclable. You can help preserve our environment by returning your used rechargeable batteries to the collection and recycling location nearest you.



For more information regarding recycling of rechargeable batteries, call toll free 1-800-822-8837, or visit <http://www.rbrc.org/>

Caution: Do not handle damaged or leaking lithium-ion batteries.

For the customers in Europe

This product with the CE marking complies with the EMC Directive (89/336/EEC) issued by the Commission of the European Community.

Compliance with this directive implies conformity to the following European standards:

- EN55103-1: Electromagnetic Interference (Emission)
- EN55103-2: Electromagnetic Susceptibility (Immunity)

This product is intended for use in the following Electromagnetic Environment(s):

E1 (residential), E2 (commercial and light industrial), E3 (urban outdoors) and E4 (controlled EMC environment, ex. TV studio).

For the customers in Taiwan only



廢電池請回收

Table of Contents

Chapter 1 Overview

1-1 Features	7
1-1-1 Principal Differences Between the PDW-510/510P and PDW-530/530P.....	7
1-1-2 Camera Features	8
1-1-3 Features of the Optical Disc Drive (VDR)	8
1-1-4 Input and Outputs	9
1-1-5 Other Functions	10
1-2 Example of System Configuration ..	11
1-3 Precautions	12
1-4 MPEG-4 Visual Patent Portfolio License	12

Chapter 2 Locations and Functions of Parts and Controls

2-1 Power Supply	13
2-2 Accessory Attachments	15
2-3 Audio Functions.....	16
2-4 Shooting and Recording/Playback	
Functions	19
2-5 Output Video Operating Section	26
2-6 Menu Operating Section.....	27
2-7 Time Code System.....	29
2-8 Warnings and Indications	31
2-9 Warnings and Indications on the LCDs	
33	
2-9-1 Monochrome LCD.....	33
2-9-2 Color LCD	34
2-10 Indicators in the Viewfinder	35

Chapter 3 Recording and Playback

3-1 Handling Discs	37
3-1-1 Discs Used for Recording and Playback	
37	
3-1-2 Notes on Handling	37
3-1-3 Write-Protecting Discs	37
3-1-4 Loading and Unloading a Disc	38
3-1-5 Formatting a Disc	39
3-1-6 Handling of Discs When Recording	
Does Not End Normally (Salvage	
Function).....	39

3-2 Recording	41
3-2-1 Basic Procedures.....	41
3-2-2 Deleting Clips	43
3-2-3 Recording Essence Marks.....	43
3-2-4 Starting a Shoot with a Few Seconds of	
Pre-Stored Picture Data (Picture Cache	
Function)	45
3-2-5 Time-Lapse Video (Interval Rec	
Function)	47
3-2-6 Retaking the Most Recent Clip.....	52
3-2-7 Auto Clip List Recoding for Automatic	
Inclusion of Recorded Clips in Clip Lists	
53	

3-3 Checking Recording and Playback . 54

3-3-1 Normal Playback	54
3-3-2 Checking the Last Two Seconds of the	
Recording — Recording Review	55
3-3-3 Checking the Recording on the Color	
Video Monitor — Playback in Color.....	55
3-3-4 Thumbnail Search.....	55
3-3-5 Clip List Playback.....	57

3-4 Recording Video Signals from External Equipment..... 58

3-4-1 Recording a DV Stream From External	
Equipment	58
3-4-2 Recording Analog Composite Signals	
(with the CBK-SC01 Installed).....	59

3-5 Freezing a Picture During Playback 60

Chapter 4 Scene Selection

4-1 Overview	61
4-2 Basic Operations	62
4-2-1 Creating Clip Lists	62
4-2-2 Editing Clip Lists	63
4-3 Clip List Operations.....	66
4-3-1 Displaying the CLIP Menu	66
4-3-2 Saving the Current Clip List to Disc.....	66
4-3-3 Loading a Clip List From Disc Into the	
Current Clip List	67
4-3-4 Deleting Clip Lists From Disc	67
4-3-5 Clearing the Current Clip List	68
4-3-6 Setting the Start Time code of the	
Current Clip List	68

4-4 Using the PDZ-1 Proxy Browsing

Software 69

Chapter 5 Adjustments and Settings for Recording

5-1 Setting the Recording Format (PDW-530/530P only) 70
5-1-1 Setting the Video Recording Format 70
5-1-2 Setting the Audio Recording Format 71

5-2 Adjusting the Black Balance and the White Balance 72
5-2-1 Adjusting the Black Balance 72
5-2-2 Adjusting the White Balance 73

5-3 Setting the Electronic Shutter 76
5-3-1 Shutter Modes 76
5-3-2 Selecting the Shutter Mode and Shutter Speed 76

5-4 Changing the Reference Value for Automatic Iris Adjustment 79

5-5 Adjusting the Audio Level 81
5-5-1 Manually Adjusting the Audio Levels of the Audio Inputs From the AUDIO IN CH1/CH2 Connectors 81
5-5-2 Manually Adjusting the Audio Level of the Front Microphone 82
5-5-3 Recording Audio on Channels 3 and 4 83

5-6 Setting the Time Data 84
5-6-1 Setting the Time Code 84
5-6-2 Saving the Actual Time in the Time Code 84
5-6-3 Setting the User Bits 84
5-6-4 Synchronizing the Time Code 85

5-7 Setting the Thumbnail Image 87

Chapter 6 File Operations

6-1 Overview 88
6-1-1 Directory Structure 88
6-1-2 File Operation Restrictions 89

6-2 File Access Mode File Operations... 91

6-3 FTP File Operations 93
6-3-1 Command List 95

Chapter 7 Menu Displays and Detailed Settings

7-1 Menu Organization and Operation 100

7-1-1 Menu Organization 100
7-1-2 Displaying Menus 101
7-1-3 Basic Menu Operations 101
7-1-4 Editing the USER Menu 103

7-2 Status Display on the Viewfinder

Screen 107
7-2-1 Layout of the Status Display on the Viewfinder Screen 107
7-2-2 Selecting the Display Items 109
7-2-3 Display Modes and Setting Change Confirmation/Adjustment Progress Messages 110
7-2-4 Setting the Marker Display 111
7-2-5 Setting the Viewfinder 111
7-2-6 Recording Shot Data Superimposed on the Color Bars 112
7-2-7 Setting the Shot ID 113
7-2-8 Displaying the Status Confirmation Windows 114
7-2-9 Confirming the Image of the Return Video Signal in the Viewfinder 116

7-3 Adjustments and Settings from Menus 117

7-3-1 Setting Gain Values for the GAIN Selector Positions 117
7-3-2 Selecting the Output Signals 117
7-3-3 Setting the Color Temperature Manually 118
7-3-4 Specifying an Offset for the Auto White Balance Setting 119
7-3-5 Assigning Functions to ASSIGN 1/2/3/4 Switches 120
7-3-6 Setting the Date/Time of the Internal Clock 122
7-3-7 Selecting the Lens File 122
7-3-8 Selecting the Aspect Ratio 123
7-3-9 Setting the CCD Scan Mode 124
7-3-10 Using UMID Data 126
7-3-11 Making Network Settings 128

7-4 Resetting USER Menu Settings to the Standard Settings 130

Chapter 8 Saving and Loading User Setting Data

8-1 Saving and Loading User Files to and from a “Memory Stick” 131
8-1-1 Handling the “Memory Stick” 131
8-1-2 Saving User Menu Data to the “Memory

- Stick” 132
- 8-1-3 Loading saved data from a “Memory Stick” 134
- 8-2 Saving and Loading Scene Files .. 136**
- 8-2-1 Saving a Scene File..... 136
- 8-2-2 Loading Scene Files..... 138
- 8-2-3 Resetting the Settings of the Camcorder to the Standard Settings Saved in the Reference File 139
- 8-3 Jumping to a File-Related Menu Page When Inserting a “Memory Stick” 140**

Chapter 9 Setting Up the Camcorder

- 9-1 Power Supply 142**
- 9-1-1 Using a Battery Pack 142
- 9-1-2 Avoiding Breaks in Operation Due to an exhausted Battery..... 143
- 9-1-3 Using an AC Adaptor 143
- 9-1-4 Using the Anton Bauer Ultralight System..... 143
- 9-2 Adjusting the Viewfinder 144**
- 9-2-1 Adjusting the Viewfinder Position 144
- 9-2-2 Adjusting the Viewfinder Focus and Screen..... 144
- 9-2-3 Detaching the Viewfinder..... 145
- 9-2-4 Moving the viewfinder shoe up 145
- 9-2-5 Using the BKW-401 Viewfinder Rotation Bracket 145
- 9-2-6 Detaching the Eyepiece 146
- 9-3 Mounting the Lens 147**
- 9-4 Adjusting the Flange Focal Length 148**
- 9-5 Audio Input System 148**
- 9-5-1 Using the Supplied Microphone 148
- 9-5-2 Using an External Microphone..... 149
- 9-5-3 Attaching a UHF Portable Tuner (for a UHF Wireless Microphone System)150
- 9-5-4 Connecting Line Input Audio Equipment..... 152
- 9-6 Tripod Mounting..... 153**
- 9-7 Attaching the Shoulder Strap 154**
- 9-8 Adjusting the Shoulder Pad Position.. 154**
- 9-9 Connecting the Remote Control Unit.. 155**

Chapter 10 Maintenance

- 10-1 Testing the Camcorder Before**

- Shooting..... 157**
- 10-1-1 Preparations for Testing..... 157
- 10-1-2 Testing the Camera..... 157
- 10-1-3 Testing the VDR..... 158
- 10-2 Maintenance 161**
- 10-2-1 Cleaning the Viewfinder..... 161
- 10-3 Operation Warnings..... 162**

Appendixes

- Specifications..... 165**
- General 165
- Video Camera Section..... 165
- Optical Disc Drive Section..... 166
- Recommended Additional Equipment 167
- Menu List 168**
- OPERATION Menu List..... 168
- PAINT Menu List..... 175
- MAINTENANCE Menu List 180
- FILE Menu List 189
- DIAGNOSIS Menu List..... 191
- About a “Memory Stick” 193**
- Glossary..... 195**
- Index..... 198**

1-1 Features

The PDW-510/510P/530/530P is a camcorder for ENG ¹⁾ and EFP ²⁾, in which a color video camera using $\frac{2}{3}$ -inch high-definition CCDs of a 16:9 aspect ratio and a Professional Disc drive are combined integrally. The camera's CCDs have approximately 1,000,000 picture elements (pixels) (the number of effective pixels: approximately 500,000).

In addition to the well-established high image quality and vibration resistant, dustproof, and dripproof constructions of the Betacam SP/SX camcorders, this unit adds a range of new functionality exploiting the capabilities of optical discs.

1) ENG: Electronic News Gathering

2) EFP: Electronic Field Production

1-1-1 Principal Differences Between the PDW-510/510P and PDW-530/530P

There are the following differences between the PDW-510/510P and PDW-530/530P in the specifications of recording format, internal optical filters, and so on.

PDW-510/510P recording format and internal optical filters

Recording format	DVCAM compatible recording	Video	25 Mbps DVCAM ¹⁾ format
		Audio	16 bits, 48 kHz, 4 channels
		Recording time	85 minutes
Optical filters	Single integrated filter system for CC (color correction) and ND (neutral density)		

PDW-530/530P recording format and internal optical filters

Recording format	DVCAM compatible recording	Video	25 Mbps DVCAM format
		Audio	16 bits, 48 kHz, 4 channels
		Recording time	85 minutes
	MPEG IMX compatible recording	Video	MPEG IMX ²⁾ format (4:2:2 high image quality video recording using MPEG2 intra frames)
		Audio	16 bits or 24 bits ³⁾ , 48 kHz sampling, 4 channels
		Recording time	50 Mbps: 45 minutes 40 Mbps: 55 minutes 30 Mbps: 68 minutes

Optical filters	Separate CC filters and ND filters; two filters can be used simultaneously
------------------------	--

- 1) DVCAM is a trademark of Sony Corporation.
- 2) MPEG IMX is a trademark of Sony Corporation.
- 3) For analog audio input, the effective bit length is maximum 20 bits.

The following characteristics are common to the PDW-510/510P and PDW-530/530P.

1-1-2 Camera Features

2/3-inch Power HAD EX CCDs

The three high sensitivity, low smear 2/3-inch Power HAD¹⁾ EX CCDs provide high image quality which is at the top of its class for a standard definition camcorder.

- The unit is switchable between a 16:9 aspect ratio wide image and 4:3 standard aspect ratio.
- You can select an interlaced scan mode or progressive scan mode (30 fps (frames per second)²⁾ for the PDW-510/530, 25 fps for the PDW-510P/530P).
- With the optional CBK-FC01 Pull Down Board installed, a 24 fps³⁾ progressive scan video can be recorded subjected to pull-down, providing imaging quality close to that of film. (PDW-510/530 only)

- 1) Abbreviation of "Power Hole-Accumulated Diode." "Power HAD" is a registered trademark of Sony Corporation.
- 2) More precisely, 29.97 fps
- 3) More precisely, 23.98 fps

Camera signal processing for high quality video

- The 12-bit A/D converter provides high image quality, stability, and reliability.
- The high-performance electronic shutter allows you to select extended clear scan mode (ECS¹⁾) and high vertical resolution mode (EVS²⁾), to obtain clear, high-quality video.

- 1) ECS: Extended Clear Scan
- 2) EVS: Super Enhanced Vertical Definition System

Shooting functions to cope with different shooting conditions

- A slow shutter function (up to 1/2 second) is provided as a standard feature. This allows noiseless shooting under very poor lighting conditions and a variety of expressive possibilities, such as shots of flowing streams which are smoothed out by afterimages.
- You can easily recall sets of adjustment values from memory, to match the particular lighting conditions.
- The ATW¹⁾ function provides automatic white balance adjustment in response to changing lighting conditions.
- The TruEye^{TM 2)} process yields distortion-free video, even with high intensity colors.

- The TURBO GAIN button enables an instantaneous boost of the video gain to the maximum 48 dB.

- 1) ATW: Auto Tracing White balance
- 2) TruEye: "TruEye" is a registered trademark of Sony Corporation.

Freeze mix function

This allows a still image from the previously captured video to be aligned with the video output from the camera. Thus you can adjust the camera position to get exactly the same framing for new shooting.

Wide range of menu settings

The menus provide the following operations, among others.

- Status display, message, and marker display settings
- Camera adjustment settings
- Switch function assignment
- "Memory Stick" operations

You can also assign any settings to the USER menu, to create customized menus.

Saving and recalling settings in a "Memory Stick"

Using an optional "Memory Stick"¹⁾, you can save menu settings for particular shooting conditions, for recall as required.

- 1) "Memory Stick" is a trademark of Sony Corporation.

High-functionality viewfinder

The 2-inch monochrome viewfinder allows accurate focusing.

The switch settings, automatic black balance and white balance items, status, warnings and so on appear on the viewfinder screen.

1-1-3 Features of the Optical Disc Drive (VDR)

Recording and playback in clip units

Each time you start and stop recording, this creates an independent clip.

- During recording, material is always written to unused parts of the disc. Therefore, even when playing back between shooting sessions, there is no danger of inadvertently overwriting the previous recording.
- Immediately after recording, you can delete clips you decide not to keep, allowing efficient use of the available disc capacity.
- During playback, you can check the recorded video and audio by viewing thumbnail images of clips on the disc and jumping instantly to the first frames of other clips.

- The i.LINK ¹⁾ (FAM (File Access Mode)) function allows you to transfer clip files by connecting a computer, or by connecting the unit to a network with the CBK-NC01 Network Adaptor (option).

1) i.LINK is a trademark of Sony Corporation.

Picture cache recording

Video and audio for a maximum of 10 seconds is always held in memory, so that when you start recording, it is possible to record from just before the REC START button was pressed.

Time-lapse video (intermittent recording) function

You can record video intermittently, capturing any number of frames at any desired time interval.

Proxy AV data

- Proxy AV data is low-resolution data with a video bandwidth of 1.5 Mbps and an audio bandwidth of 64 Kbps per channel. This unit records proxy AV data on the Professional Disc whenever MPEG IMX or DVCAM format data is recorded on the main channel.
- Proxy AV data is much smaller in size than the full-resolution IMX or DVCAM data. It can be transferred quickly over computer networks, easily edited in the field with laptop computers, and readily used in a wide variety of applications, such as content management on small-scale servers.

Wide range of metadata recording

In addition to video and audio, various types of additional information can be recorded on the Professional Disc ¹⁾ as metadata.

- Essence marks can be added to mark important locations in the video and audio data. Essence marks can be added manually at any frame by pressing the lens RET button or an assignable button. They can also be added automatically at locations where there is a sudden change in luminance or audio input above a specified threshold.
- The supplied logging software can be used to add titles, comments, and other text data to clips.
- Computer-readable text files can be recorded on the Professional Disc to enable systematic content management.

The ability to search metadata for the required audio and video scenes brings greater efficiency to various stages of the video production process, such as editing, and archiving.

1) Professional Disc is a trademark of Sony Corporation.

Thumbnail search

Thumbnail images of the clips on the disc can be displayed on the LCD panel and in the viewfinder by pressing the THUMBNAIL button. They can also be shown in external video output.

You can check the content of a clip simply by moving the cursor to its thumbnail and pressing the play button.

Scene selection

You can create and play back clip lists of selected clips from the disc, arranged in any order.

One disc can store up to 99 clip lists.

Clip lists make it simple to perform offline editing in the field for later use with full-scale nonlinear editing systems (XPRI ¹⁾, etc.).

1) XPRI is a trademark of Sony Corporation.

High reliability under tough operating conditions

With resistance to vibration and dust comparable to tape based camcorders, this unit can be relied on just like a conventional unit.

1-1-4 Input and Outputs

Range of audio inputs and outputs

- A super-cardioid directional monaural microphone with external power supply is supplied as standard equipment. By changing the connector (service component replacement), a stereo microphone can be fitted.
- The optional slot-in type WRR-855A/855B UHF Synthesized Tuner Unit can be installed in the unit.
- The two AUDIO IN connectors (XLR type, 3-pin) on the rear panel of the unit can be switched to line input, microphone input, or + 48V external power, and also to AES/EBU digital audio inputs (maximum 24 bits).
- When audio cables are connected to the two AUDIO IN connectors (XLR type, 3-pin) on the rear panel of the unit, an automatic detection function forces the recording of the audio input signals from these connectors as channels 1 and 2.
- The AUDIO OUT connectors (XLR type, 5-pin) provide two channels of audio output.

i (i.LINK) connector

The i.LINK connector of this unit supports the following two functions.

Input and output of DV streams (AV/C (Audio/Video Control) mode)

DV streams can be output from this unit and recorded on standard DV equipment. ¹⁾

In the same way, the output from external DV devices (VTRs, nonlinear editors, etc.) can be input to this unit and recorded on Professional Discs.²⁾

DV-compliant nonlinear editors may also be connected.

- 1) In the case of the PDW-530/530P, DV stream output is also possible when the unit is set to IMX recording mode. Audio data is recorded after conversion according to the specifications of this unit.
- 2) In the case of the PDW-530/530P, this is possible only when the unit is set to DVCAM recording mode.

Computer access to files (File Access Mode)

Use of application software¹⁾ which supports the XDCAM series enables random access to video, audio, and metadata files on Professional Discs, with the ability to display file lists and perform file-based reads and writes.

Files can be transferred at high speed, and thumbnail lists of disc contents can be viewed on computer screens.

- 1) Such software includes the supplied PDZ-1 Proxy Browsing Software and the XPRI series.

Remote control connectors

By connecting an optional RM-B150/B750 or similar remote control unit, you can control the shooting functions of this unit externally.

Function extension interface

- Installing the optional CBK-SD01 SDI Output Board enables SDI signal output from the VIDEO OUT connectors.
- By installing the optional CBK-SC01 Analog Composite Input Board, a composite video signal input to the GENLOCK connector can be recorded on this unit.
- An extension connector can be attached to the battery attachment on the rear panel, to allow various camera adapters to be fitted.

Network connector (option)

The optional CBK-NC01 Network Adaptor can be installed on this unit to enable connections to computers and networks. This makes it possible to transfer files at high speeds, and to display of lists of the video, audio, and metadata files stored on Professional Discs. Workflows can be improved by the ability to use FTP commands to transfer files to remote locations over networks.

1-1-5 Other Functions

Usability-oriented design

- There is more space around the rear panel connectors than on previous models, making cable connections and switch operations easier.
- The adjustment range of the shoulder pad in the front to rear direction is increased, making it easier to ensure proper balance when using the unit.

2.5-inch color LCD panel

The side of the unit has an LCD that can be switched to show the following images and data.

- Status information, including audio level meters and time code
- Thumbnails of the video recorded on the Professional Disc
- A playback image of the video recorded on the Professional Disc
- The camera image

Monochrome LCD panel

Even when this unit is powered off, the time code, remaining disc capacity, battery capacity, and other status information appears on the monochrome LCD. (This requires either a battery or a DC power supply connected.)

Instant operation assignable switches

Two switches provided on the side panel and on the top of the grip, respectively, can be assigned to any functions, by a menu operation.

Furthermore, the TURBO GAIN button can also be used as an assignable switch.

Alarm function

If a fault is detected on the optical disc drive, or if the disc or battery capacity is low, notification is provided by warning indicators and audible alarms.

SMPTE (PDW-510/530)/EBU (PDW-510P/530P) color bars, and 1 kHz reference signal output

Adjustment of a color monitor or external audio device is easy. Color bars for an SNG¹⁾ uplink are also provided.

- 1) SNG: Satellite News Gathering

Viewfinder height adjustable

In addition to the front to rear and left to right directions, the viewfinder can be adjusted vertically in two steps.

Supports SNMP¹⁾ for maintenance and service (option)

The SNMP-compliant Sony Remote Maintenance and Monitoring Software can be used when the optional CBK-NC01 Network Adaptor is installed on this unit. Via a TCP/IP network connection, this software can monitor the hardware status of this unit in real time and record monitoring logs. This allows you to analyze the problem immediately and take the necessary steps whenever a hardware failure is detected.

- 1) To be supported shortly.

1-2 Example of System Configuration

The diagram below shows a typical configuration of the camcorder for ENG and EFP.

For more information about the fittings, connections, or use of additional equipment and accessories, see Chapter 9 as well as the operation manuals for the connected equipment.

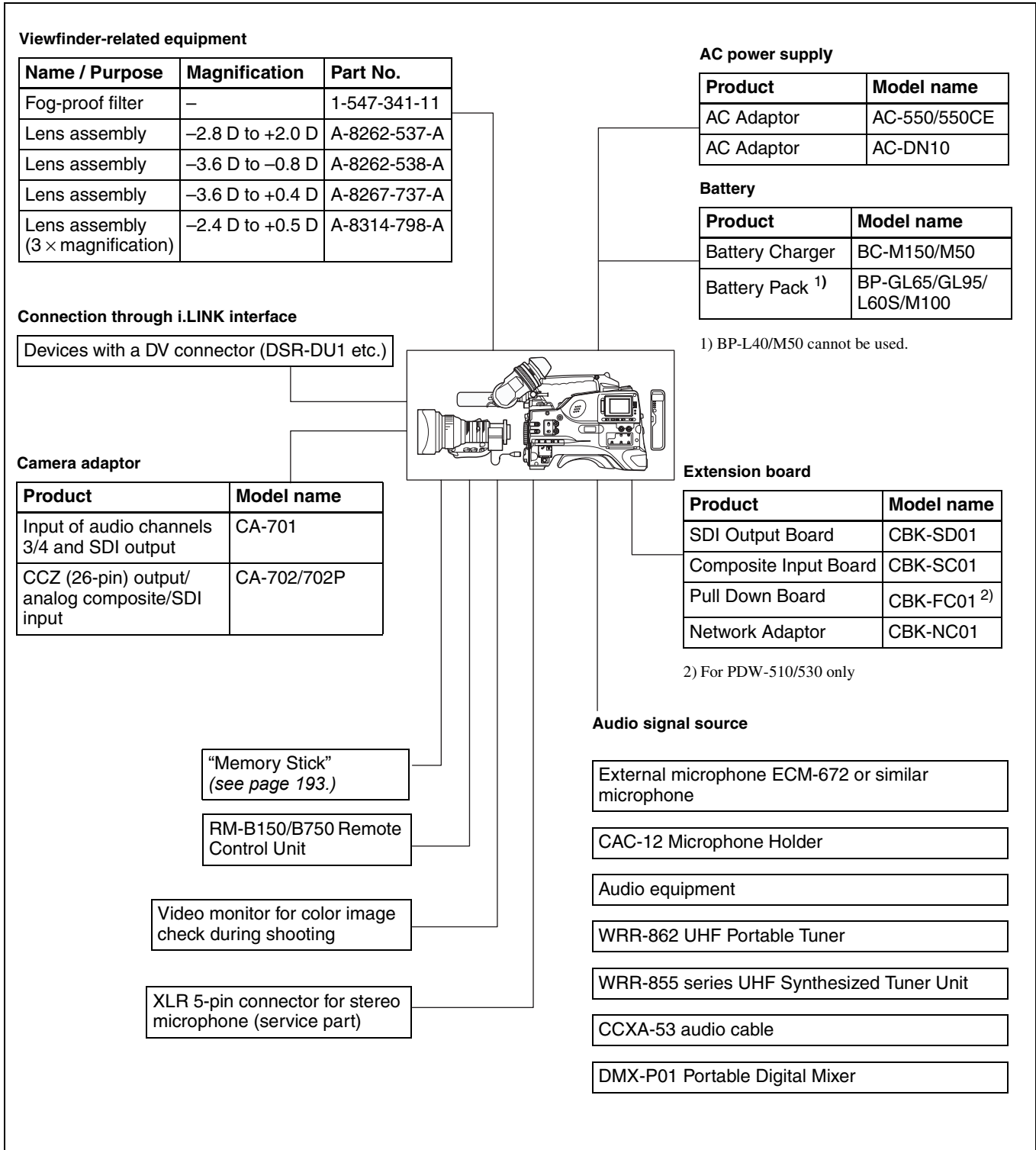

1-3 Precautions

Use and Storage

Do not subject the unit to severe shocks

The internal mechanism may be damaged or the body warped.

After use

Always turn off the power.

Before storing the unit for a long period

Remove the battery pack.

Use and storage locations

Store in a level, ventilated place. Avoid using or storing the unit in the following places.

- Places subject to temperature extremes
- Very damp places
- Places subject to severe vibration
- Near strong magnetic fields
- In direct sunlight or close to heaters for extended periods

To prevent electromagnetic interference from portable communications devices

The use of portable telephones and other communications devices near this unit can result in malfunctions and interference with audio and video signals.

It is recommended that the portable communications devices near this unit be powered off.

Note on laser beams

Laser beams may damage the CCDs. If you shoot a scene that includes a laser beam, be careful not to let the laser beam be directed into the lens of the camera.

Use at a high temperature

If the unit is used at a high temperature, white flecks may appear on the screen.

About the LCD panels

LCD panels are manufactured with extremely high-precision technology that yields effective pixel rates of 99.99% or higher. However, very rarely, one or more pixels may be permanently dark or permanently lit in white, red, blue, or green.

This phenomenon is not a malfunction. Such pixels have no effect on the recorded data, and the unit may be used with confidence even if they are present.

1-4 MPEG-4 Visual Patent Portfolio License

This product is licensed under the MPEG-4 Visual Patent Portfolio License. For the personal and non-commercial use of a consumer for (i) encoding video in compliance with the MPEG-4 Visual Standard (“MPEG-4 Video”) and/or (ii) decoding MPEG-4 Video that was encoded by a consumer engaged in a personal and non-commercial activity and/or was obtained from a video provider licensed by MPEG LA to provide MPEG-4 Video.

No license is granted or shall be implied for any other use. Additional information including that relating to promotional, internal and commercial uses and licensing may be obtained from MPEG LA, LLC.

See <http://www.mpegla.com>

Locations and Functions of Parts and Controls

Chapter 2

2-1 Power Supply

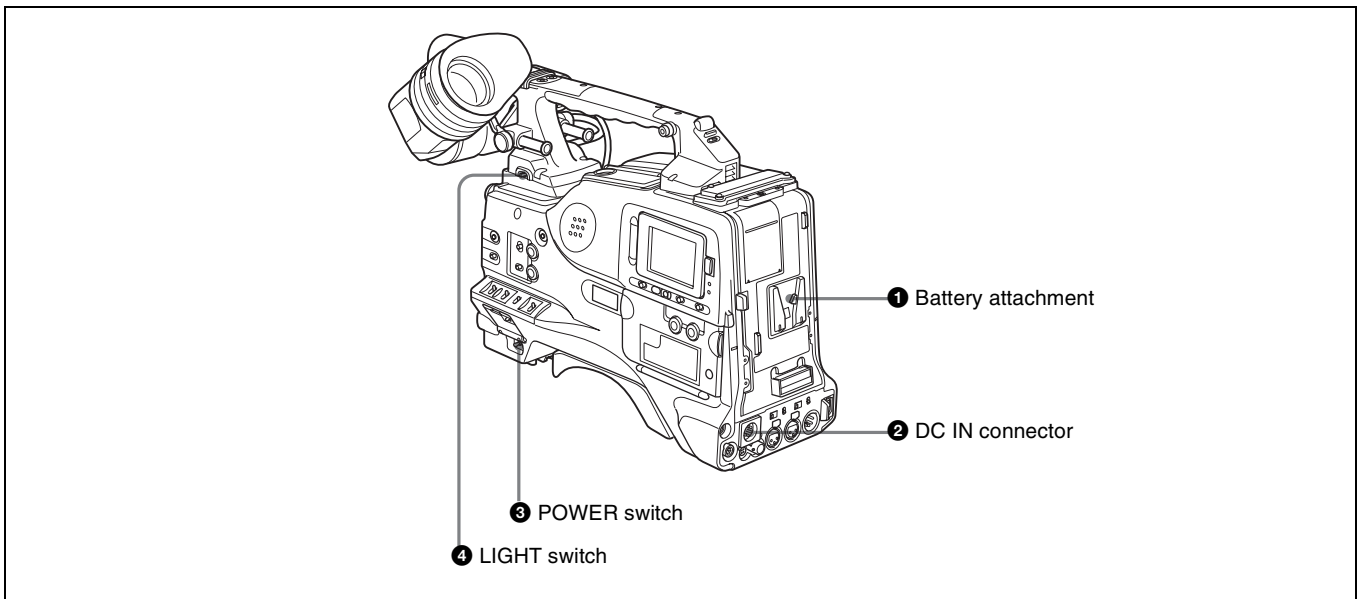

1 Battery attachment

Attach a BP-GL65/GL95/L60S/M100 battery pack. Furthermore, by attaching an AC-DN10 AC Adaptor, you can operate the camcorder from AC power.

Note

For your safety, and to ensure proper operation of the unit, Sony recommends the use of the following battery packs: BP-GL65, BP-GL95, BP-L60S, and BP-M100.

2 DC IN connector (XLR type, 4-pin, male)

To operate the camcorder using an AC power supply, connect an AC-550/550CE AC Adaptor with the DC output cable supplied with the adaptor.

3 POWER switch

This switch turns the main power supply on and off.

4 LIGHT switch

This determines how a video light connected to the LIGHT connector is turned on and off.

AUTO: When the switch on the video light is in the on position, putting the camcorder in recording mode turns the video light on automatically. When using the auto interval recording mode, the video light is automatically turned on immediately before recording starts.

MANUAL: You can turn the video light on or off manually, using its own switch.

Notes

- When AUTO is selected, unevenly lit video is recorded between the start of recording and the time when the light comes on. We recommend that you select MANUAL when the start of a recording is important.

However, the light can be turned on before the start of recording in auto interval recording mode.

- To ensure proper operation of the video light with the unit, Sony recommends the use of the following battery packs: BP-GL65, BP-GL95, BP-L60S, and BP-M100.

2-2 Accessory Attachments

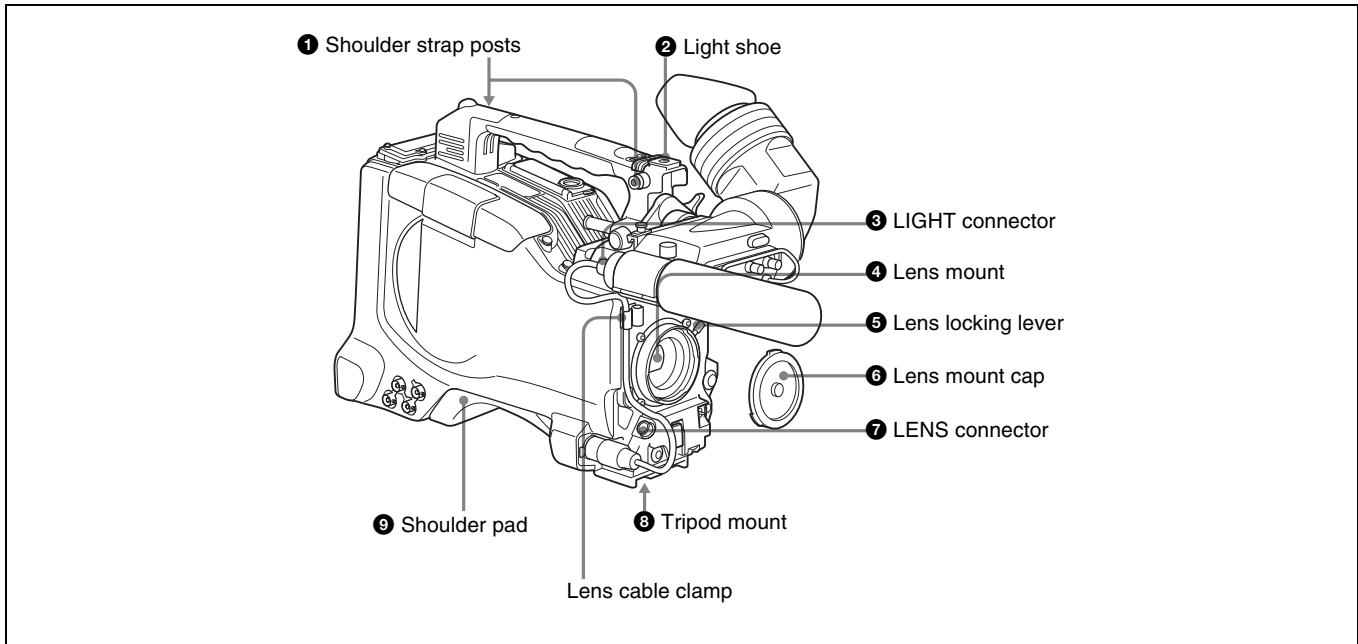

1 Shoulder strap posts

Attach the supplied shoulder strap to these posts.

For details, see 9-7 “Attaching the Shoulder Strap” on page 154.

2 Light shoe

Attach an optional accessory such as a video light to this shoe.

3 LIGHT connector (2-pin, female)

Connect the cable of an Anton Bauer Ultralight System attached to the light shoe. The system operates with lights powered by 12 V, with a maximum power consumption of 50 W.

4 Lens mount (special bayonet mount)

Use this for mounting the lens.

5 Lens locking lever

After inserting the lens in the lens mount, rotate the lens mount ring with this lever to lock the lens in position.

6 Lens mount cap

Remove this cap by pushing up the lens locking lever. When no lens is mounted, keep this cap fitted for protection from dust.

7 LENS connector (12-pin)

Fit the lens cable to this connector. Contact your Sony representative for more information about the lens you can use.

8 Tripod mount

When using the camcorder on a tripod, attach the tripod adaptor (option).

9 Shoulder pad

You can move the shoulder pad forwards or backwards by raising up the shoulder pad locking lever. Do this to ensure the best balance when shooting with the camcorder on your shoulder.

For details, see 9-8 “Adjusting the Shoulder Pad Position” on page 154.

2-3 Audio Functions

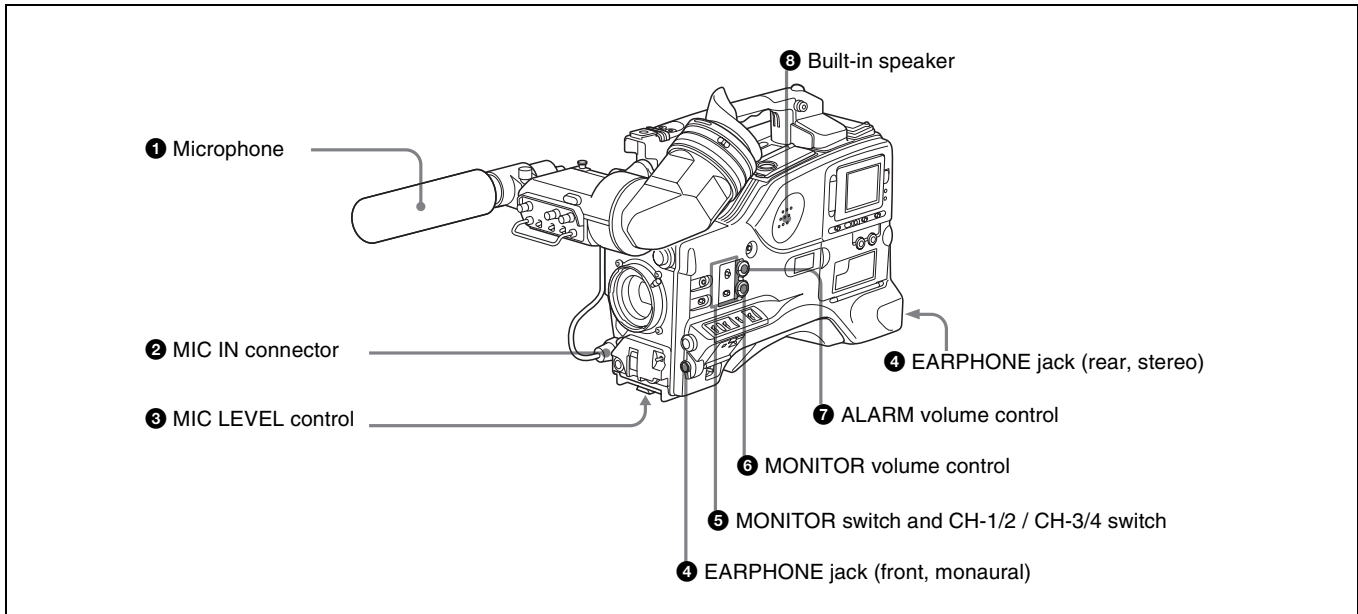

Audio functions (1)

1 Microphone

This is a super-cardioid directional monaural microphone with an external power supply (+48 V) system.

2 MIC IN (microphone input) connector (XLR type, 3-pin, female)

Connect the supplied microphone to this connector. A microphone other than the supplied one may also be connected as long as it can operate with the power (+48 V) supplied from this connector.

By fitting a 5-pin connector (service part number: A-1053-453-A), you can also use a stereo microphone.

3 MIC (microphone) LEVEL control

This control adjusts the audio level of the microphone connected to the MIC IN connector.

4 EARPHONE jack (front) (monaural, minijack) / EARPHONE jack (rear) (monaural/stereo switchable, minijack)

You can monitor the E-E sound ¹⁾ during recording and playback sound during playback. Plugging an earphone into the jack automatically cuts off the built-in speaker. When an alarm is indicated, you can hear the alarm sound through the earphone.

You can use the rear EARPHONE jack for stereo output, by setting the HEADPHONE OUT item in the AUDIO-1 page of the MAINTENANCE menu to "STREO". You can also connect a monaural earphone to the front jack and a monaural/stereo earphone set to the rear jack simultaneously.

1) E-E: Abbreviation of "Electric-to-Electric." In E-E mode, video and audio signals input to the camcorder are output after passing through internal electric circuits only. This can be used to check input signals.

5 MONITOR switch and CH-1/2 / CH-3/4 switch

These switches together determine the channel selection for audio monitor output.

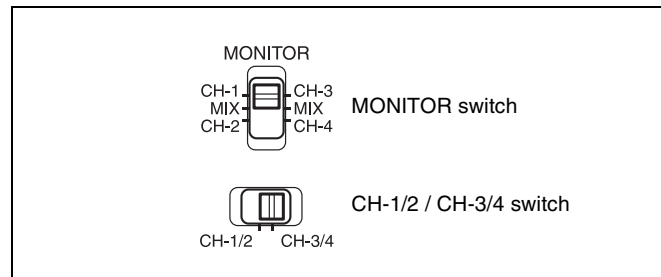

MONITOR switch and CH-1/2 / CH-3/4 switch

CH-1/2 / CH-3/4 switch:

This determines the pair of audio channels selected with the MONITOR switch.

CH-1/2 position: channels 1 and 2

CH-3/4 position: channels 3 and 4

The signals output from the AUDIO OUT connector and EARPHONE jacks also depend on the setting of this switch.

MONITOR switch:

This selects the audio monitor channels output to the monaural earphone or speaker, depending on the setting of the CH-1/2 / CH-3/4 switch.

CH-1/2 CH-3/4 switch position	MONITOR switch position	Audio output
CH-1/2	CH-1	Audio channel 1
	MIX	Mix sound of channels 1 and 2
	CH-2	Audio channel 2
CH-3/4	CH-3	Audio channel 3
	MIX	Mix sound of channels 3 and 4
	CH-4	Audio channel 4

6 MONITOR volume control

This control adjusts the speaker or earphone volume for sounds other than the alarm sound. At the minimum position, no sound can be heard.

7 ALARM volume control

This control adjusts the speaker or earphone alarm volume. At the minimum position, no sound can be heard. However, if in the AUDIO-1 page of the MAINTENANCE menu the MIN ALARM VOL item is set to "SET", the alarm tone is audible even when this volume control is at the minimum position.

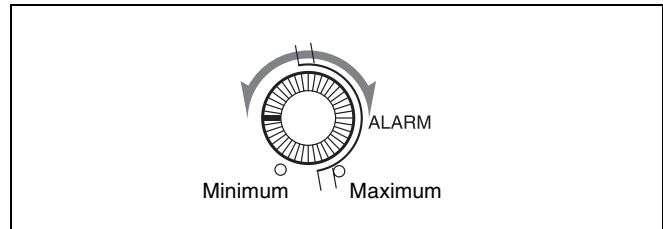

ALARM volume control

8 Built-in speaker

The speaker can be used to monitor E-E sound during recording, and playback sound during playback. The speaker also sounds alarms to reinforce visual warnings. The output level of the speaker can be lowered by changing the setting of the SP ATT LEVEL item on the AUDIO-1 page of the MAINTENANCE menu. If you connect an earphone to the EARPHONE jack, the speaker is automatically muted.

See 10-3 "Operation Warnings" on page 162 for information about alarms.

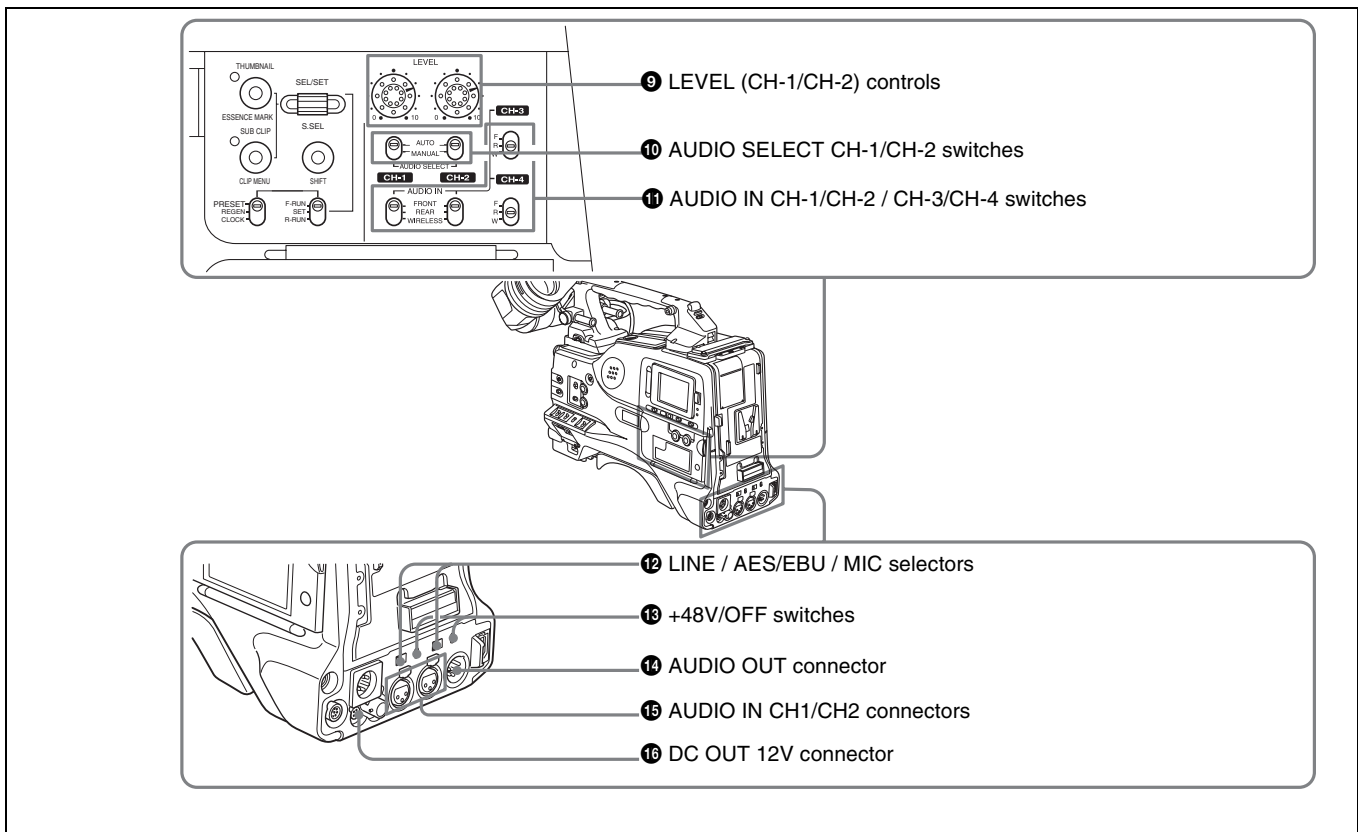

Audio functions (2)

9 LEVEL (CH-1/CH-2) (audio channel-1 and channel-2 recording level) controls

These controls adjust the audio levels of channels 1 and 2 when the AUDIO SELECT switches are set to MANUAL.

⑩ AUDIO SELECT CH-1/CH-2 (audio channel-1 and channel-2 adjustment method selection) switches

These switches select the audio level adjustment method for each of audio channels 1 and 2.

AUTO: Select this setting for automatic adjustment.

MANUAL: Select this setting for manual adjustment.

⑪ AUDIO IN CH-1/CH-2 / CH-3/CH-4 (audio input selection) switches

AUDIO IN CH-1/CH-2 switches

These switches select the audio input signals to be recorded on audio channels 1 and 2.

FRONT: The input signal source is the microphone connected to the MIC IN connector.

REAR: The input signal source is the audio equipment connected to the AUDIO IN CH1/CH2 connectors.

WIRELESS: The input signal source is a WRR-855A/855B UHF Synthesized Tuner Unit (option).

AUDIO IN CH-3/CH-4 switches

These switches select the audio input signals to be recorded on audio channels 3 and 4.

F (front): The input signal source is the microphone connected to the MIC IN connector.

R (rear): The input signal source is the audio equipment connected to the AUDIO IN CH1/CH2 connectors.

W (wireless): The input signal source is a WRR-855A/855B UHF Synthesized Tuner Unit.

With a CA-701 Camera Adaptor (option) connected to the camcorder, you can record separate sounds on audio channels 3 and 4.

⑫ LINE /AES/EBU / MIC selectors

These select the audio source of the audio input signals input to the AUDIO IN CH1/CH2 connectors.

LINE: Line input audio equipment

AES/EBU: AES/EBU format audio signal

MIC: Microphone input

Note

When these switches are in the MIC position, and the +48V switch described below is on, if you inadvertently connect any audio device other than a microphone to the AUDIO IN CH1/CH2 connectors, the device may be damaged.

⑬ +48V/OFF switches

Select either of the following positions for the microphones to be connected.

+48V: For a microphone to use an external power supply

OFF: For a microphone to use an internal power supply

⑭ AUDIO OUT (audio output) connector (XLR type, 5-pin, male)

This connector outputs the audio signals recorded on audio channels 1 and 2 or audio channels 3 and 4.

The MONITOR CH-1/2 / CH-3/4 switches allow you to select the audio signal to be monitored.

⑮ AUDIO IN CH1/CH2 (audio channel-1 and channel-2 input) connectors (XLR type, 3-pin, female)

These are audio input connectors for channels 1 and 2 to which you can connect audio equipment or a microphone. When the LINE / AES/EBU / MIC selector is set to AES/EBU, the CH1 connector is used for channel-1 and -2 inputs, and the CH2 connector, for channel-3 and -4 inputs.

⑯ DC OUT 12 V (DC power output) connector (4-pin, female)

This connector supplies power for a WRR-862 UHF Portable Tuner (option). Do not connect any equipment other than the UHF portable tuner.

2-4 Shooting and Recording/Playback Functions

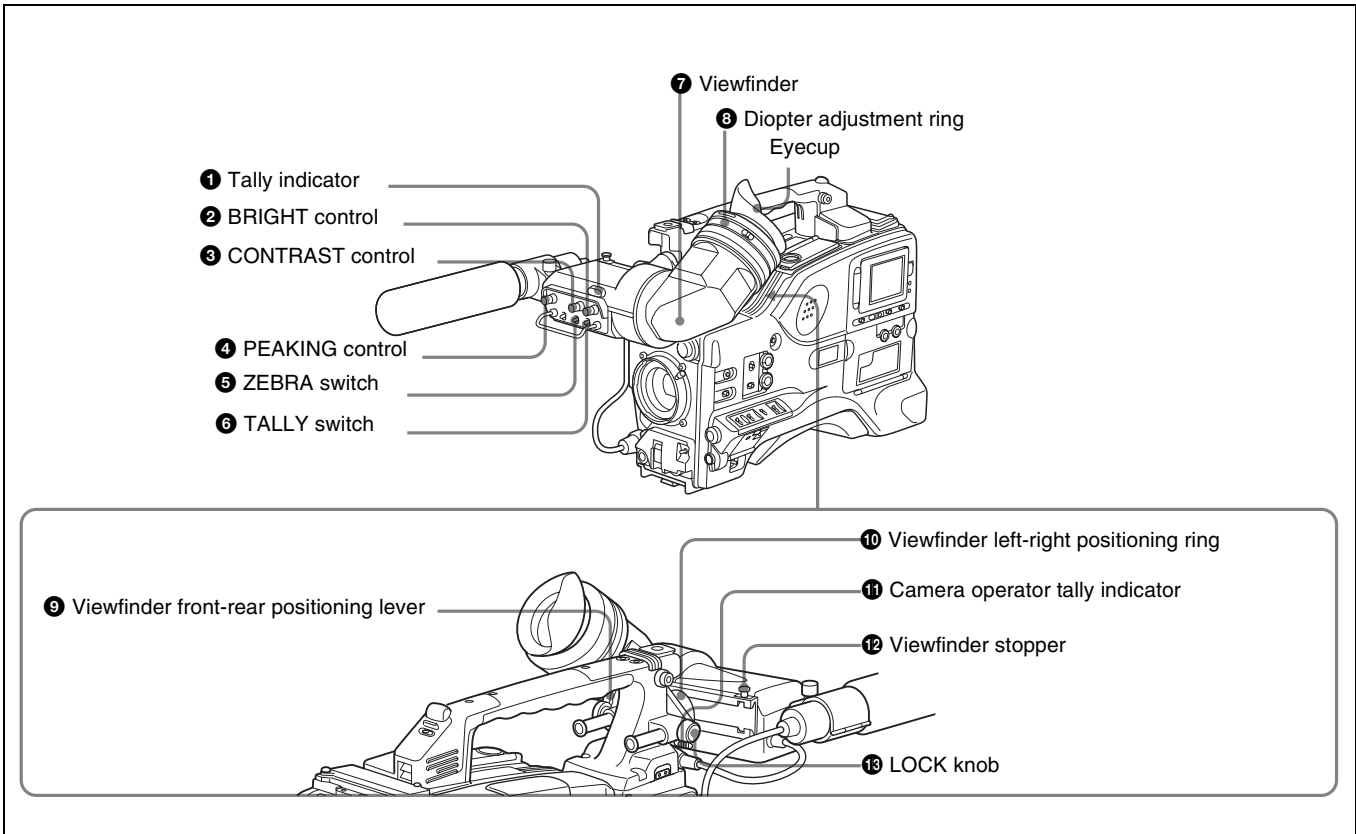

Shooting and recording/playback functions (1)

1 Tally indicator

Setting the TALLY switch to HIGH or LOW enables this indicator. The indicator lights during recording on the VDR (video disc recorder). Like the REC indicator in the viewfinder, it flashes to indicate a problem. You can set the indicator brightness with the TALLY switch.

2 BRIGHT (brightness) control

This control adjusts the picture brightness on the viewfinder screen. It has no effect on the camera output signal.

3 CONTRAST control

This control adjusts the picture contrast on the viewfinder screen. It has no effect on the camera output signal.

4 PEAKING control

This control adjusts the sharpness of the picture on the viewfinder screen to make focusing easier. It has no effect on the camera output signal.

5 ZEBRA switch

This switch controls the zebra pattern on the viewfinder screen.

ON: The zebra pattern ¹⁾ is displayed and stays.

OFF: No zebra pattern is displayed.

MOMENT: The zebra pattern is displayed and stays for 5 to 6 seconds.

The zebra pattern is factory set to indicate picture areas where the video level is approximately 70%. You can use the setup menu to change the setting so that areas where the video level is 100% and above are also displayed at the same time.

For information about how to change the zebra pattern setting in the setup menu, see 7-2-5 "Setting the Viewfinder" on page 111.

1) The zebra pattern aids in manual iris adjustment by indicating areas of the picture where the video level is approximately 70% and 100% and above.

6 TALLY switch

This switch controls the tally indicator, setting its brightness (HIGH or LOW) or turning it off.

HIGH: The tally indicator brightness is high.

OFF: The tally indicator is disabled.

LOW: The tally indicator brightness is low.

7 Viewfinder

The viewfinder lets you view the image in black and white while shooting, recording or playing back. It also displays various warnings and messages related to the settings or operating conditions of the camcorder, a zebra pattern, safety zone marker ¹⁾, and center marker ²⁾.

- 1) The safety zone marker is a rectangle indicating the effective picture area.
2) The center marker indicates the center of the picture with a crosshair.

For details, see 7-2-4 “Setting the Marker Display” on page 111.

8 Diopter adjustment ring

Use this ring to adjust the viewfinder image for your vision.

9 Viewfinder front-rear positioning lever

To adjust the viewfinder position in the front-rear direction, loosen this lever and the LOCK knob. After adjustment, retighten this lever and the LOCK knob.

10 Viewfinder left-right positioning ring

Loosen this ring to move the viewfinder sideways.

11 Camera operator tally indicator

This indicator lights while the camcorder is recording. Slide the window open when you shoot with your eye away from the viewfinder. This indicator flashes when the battery level is running low or the disc is almost full.

12 Viewfinder stopper

Pull up this stopper to detach the viewfinder from the camera.

13 LOCK knob

To adjust the viewfinder position in the front-rear direction, loosen this knob and the viewfinder front-rear positioning lever. After adjustment, retighten this knob and the viewfinder front-rear positioning lever.

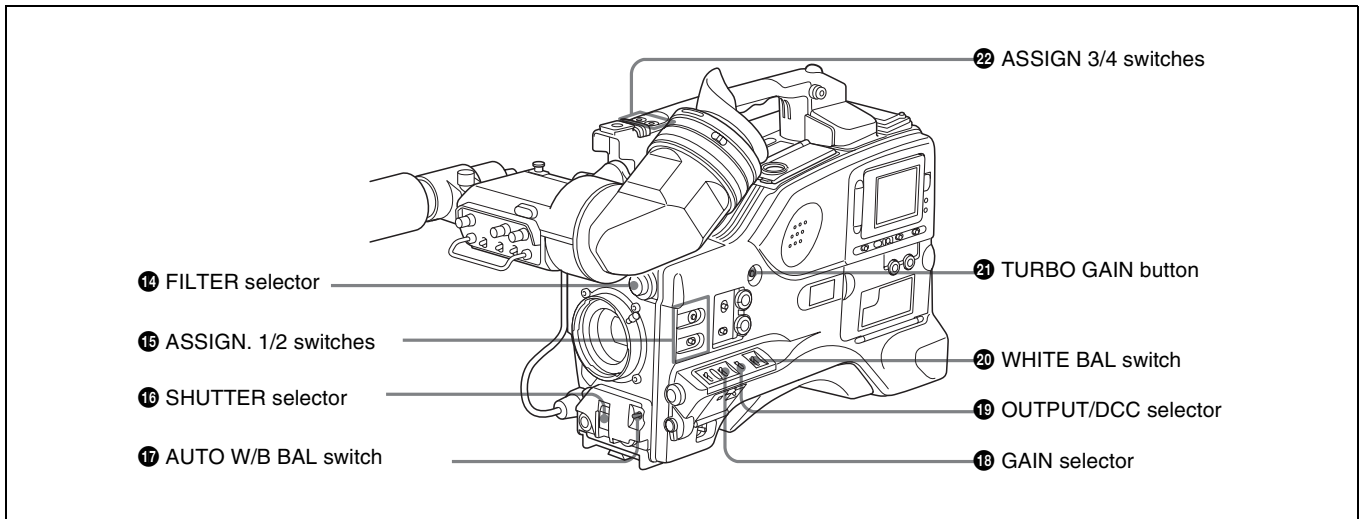

Shooting and recording/playback functions (2)

14 FILTER selector

Use this selector to select the most appropriate filter to match the light source illuminating the subject. When this selector is used with the display mode set to 3, the new setting appears on the viewfinder screen for about 3 seconds. (e.g.: FILTER: 3)

The PDW-510/510P has one switchable filter, and the PDW-530/530P has two switchable filters.

The relationships between the selector settings and filter selections as well as examples of filters for different shooting conditions are as follows.

For the PDW-510/510P

FILTER selector setting and filter selection

FILTER selector setting	Filter selection
1	3200 K
2	5600 K + $\frac{1}{8}$ ND
3	5600 K
4	5600 K + $\frac{1}{64}$ ND

Examples of shooting conditions and appropriate filters

Shooting condition	Filter
Sunrise and sunset; inside studio	1 (3200 K)
Clear skies	2 (5600 K + $\frac{1}{8}$ ND)
Cloudy or raining	3 (5600 K)

Examples of shooting conditions and appropriate filters

Shooting condition	Filter
Very bright conditions such as snow, at high altitudes, or at the seashore	4 (5600 K + 1/64 ND)

For the PDW-530/530P**FILTER selector (outer knob) setting and CC filter selection**

FILTER selector (outer knob) setting	CC filter selection
A	Cross filter ¹⁾
B	3200 K
C	4300 K
D	6300 K

1) A type of special effect filter. Generates a cross of light on a highlighted portion.

FILTER selector (inner knob) setting and ND filter selection

FILTER selector (inner knob) setting	ND filter selection
1	Clear
2	1/4 ND
3	1/16 ND
4	1/64 ND

Examples of shooting conditions and appropriate filters

Shooting condition	CC filter	ND filter
Sunrise and sunset; inside studio	B (3200 K)	1 (clear)
Clear skies	C (4300 K) or D (6300 K)	2 (1/4 ND) or 3 (1/16 ND)
Cloudy or raining	D (6300 K)	1 (clear) or 2 (1/4 ND)
Very bright conditions such as snow, at high altitudes, or at the seashore	C (4300 K) or D (6300 K)	3 (1/16 ND) or 4 (1/64 ND)

15 ASSIGN. 1/2 switches

You can assign the desired functions to each of the ASSIGN. 1 switch (push button) and ASSIGN. 2 switch (sliding) on the FUNCTION 1 page of the USER menu.

For details, see 7-3-5 “Assigning Functions to ASSIGN 1/ 2/3/4 Switches” on page 120.

16 SHUTTER selector

Set this selector to ON to use the electronic shutter. Push it down to SELECT to switch the shutter speed or mode setting within the range previously set with the setup menu.

When this selector is operated, the new setting appears on the setting change/adjustment progress message display area for about 3 seconds.

For details about the shutter speed and mode settings, see 5-3 “Setting the Electronic Shutter” on page 76.

17 AUTO W/B BAL (automatic white/black balance adjustment) switch

This switch activates the white balance and black balance automatic adjustment functions.

WHITE: Automatic adjustment of the white balance. If the WHITE BAL switch is set to A or B, the white balance setting is stored in the corresponding memory. On the PDW-530/530P models with two switchable filters, the memory stores a separate white balance setting for each CC filter setting.

BLACK: Automatic adjustment of the black set and black balance.

18 GAIN selector

This selector switches the gain of the video amplifier to match the lighting conditions during shooting. The gains corresponding to the L, M, and H settings can be selected from the setup menu. The factory settings are L = 0 dB, M = 9 dB, and H = 18 dB.

When this selector is adjusted, the new setting appears on the setting change/adjustment progress message display area of the viewfinder screen for about 3 seconds.

For details about setting the gain values, see 7-3-1 “Setting Gain Values for the GAIN Selector Positions” on page 117.

19 OUTPUT/DCC (output signal/dynamic contrast control) selector

This selector switches the video signal that is output to the VDR, viewfinder, and video monitor, between the following two.

BARS: Outputs the color bar signal.

CAM: Outputs the video signal from the camera. When this is selected, you can switch DCC ¹⁾ on and off with this selector.

1) DCC (Dynamic Contrast Control)

Against a very bright background with the iris opening adjusted to the subject, objects in the background will be lost in the glare. The DCC function will suppress the high intensity and restore much of the lost detail and is particularly effective in the following cases.

- Shooting people in the shade on a sunny day
- Shooting a subject indoors, against a background through a window
- Any high contrast scene

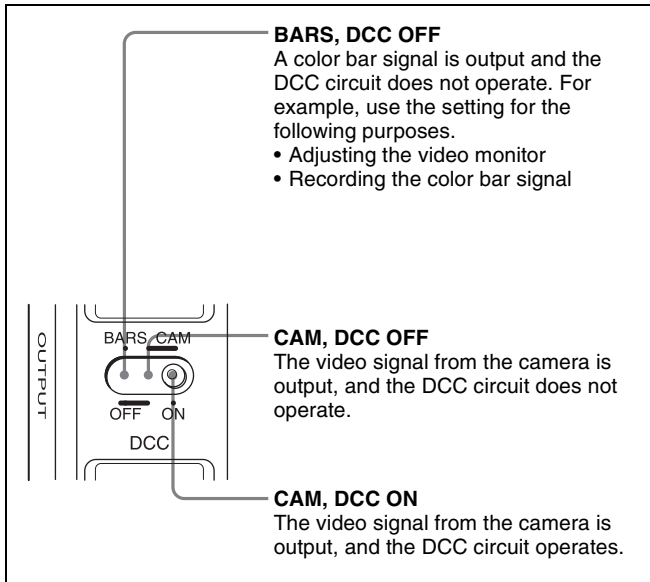

OUTPUT/DCC selector

20 WHITE BAL (white balance memory) switch

This switch controls the white balance setting.

PRST (preset): Adjusts the color temperature corresponding to the position of the FILTER selector. Use the PRST setting when you have no time to adjust the white balance.

A or B: When the AUTO W/B BAL switch is pushed to WHT, the white balance is automatically adjusted according to the current position of the FILTER selector, and the adjusted value is stored in either memory A or memory B. (There are two memories for each CC filter, allowing a total of eight adjustments to be stored.) When this switch is set to A or B, the camcorder automatically adjusts itself to the stored value corresponding to the current settings of this

switch and the FILTER selector.

You can use the AUTO W/B BAL switch even when ATW¹⁾ is in use.

B (ATW): When this switch is set to B and on the FUNCTION 2 page of the OPERATION menu, “WHITE B CH” is set to “ATW”¹⁾, ATW is activated.

1) ATW (Auto Tracing White Balance)

The white balance of the picture being shot is adjusted automatically for varying lighting conditions.

When this switch is adjusted, the new setting appears on the setting change/adjustment progress message display area of the viewfinder screen for about 3 seconds.

You can assign the ATW ON/OFF function to the ASSIGN 1 switch (push button) on the FUNCTION 1 page of the USER menu.

For details, see 7-3-5 “Assigning Functions to ASSIGN 1/2/3/4 Switches” on page 120.

21 TURBO GAIN button

When shooting under extremely poor lighting conditions, press the button once to boost the video gain to the value preset on the GAIN SW page of the USER menu (up to 48 dB). To stop boosting the gain, press the button once more.

22 ASSIGN 3/4 switches

You can assign the desired functions to each of the ASSIGN 3 switch and ASSIGN 4 switch on the FUNCTION 1 page of the USER menu.

For details, see 7-3-5 “Assigning Functions to ASSIGN 1/2/3/4 Switches” on page 120.

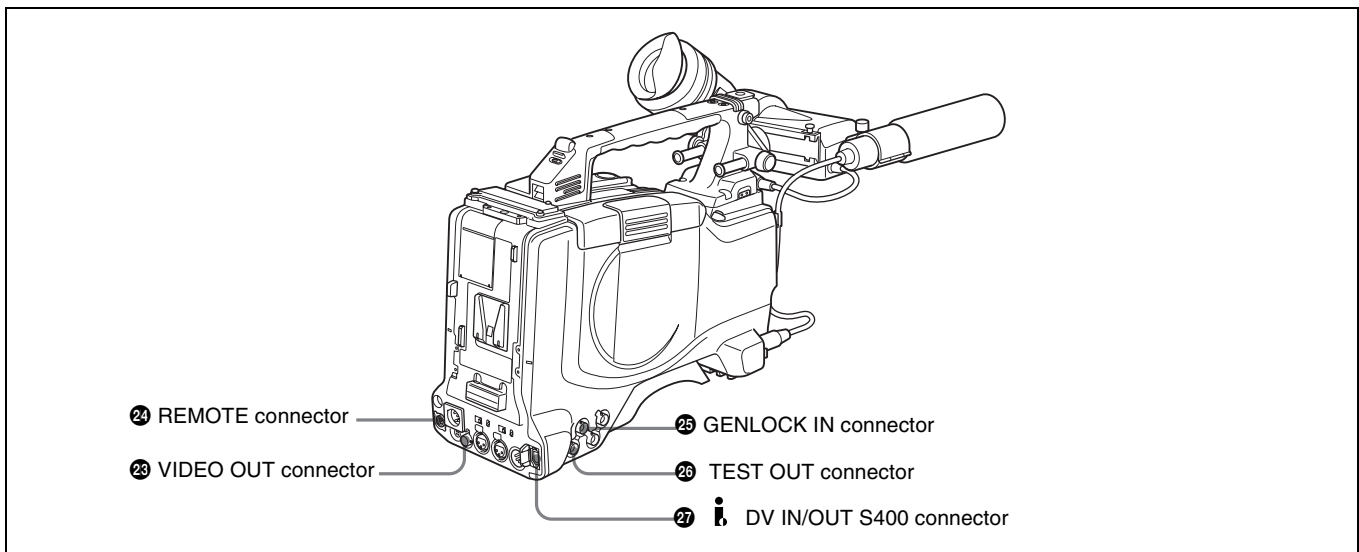

Shooting and recording/playback functions (3)

23 VIDEO OUT connector (BNC type)

This connector outputs a composite video signal for a video monitor. With a video monitor connected to this connector, you can monitor the picture being shot by the camera or the picture played back by the VDR. To choose between the composite video signal output and SDI signal output, use the menu. When synchronizing the time code of an external VDR with that of the camcorder, connect this connector to the GENLOCK IN connector of the external VDR.

By installing the CBK-SD01 extension board (not supplied), you can output an SDI signal (supporting embedded audio and the EDH function) from this connector.

For details on how to select the output signal, see 7-3-2 "Selecting the Output Signals" on page 117.

24 REMOTE connector (8-pin)

Connect the RM-B150/B750 Remote Control Unit, which makes it possible to control the VDR and camera remotely.

25 GENLOCK IN connector (BNC type)

- This connector inputs a reference signal when the camera is to be genlocked or when time code is to be synchronized with external equipment. Use the MAINTENANCE menu to adjust the genlock H-phase (phase of horizontal sync signal) and the sub-carrier phase.

For details, refer to the Maintenance Manual.

- This connector also inputs a return video signal. You can display the return video signal in the viewfinder screen while holding the RET button down with "RETURN VIDEO" set to "ON" on the GENLOCK page of the OPERATION menu.
- This connector also inputs an external analog composite video signal. When the CBK-SC01 extension board is installed, you can record the external analog composite video signal input to this connector.

26 TEST OUT connector (BNC type)

This connector outputs the video signal for a video monitor. The output signal can be selected from composite or RGB. The factory setting is composite, and the setting returns to composite whenever the unit is powered on. Depending on internal board and menu settings, menus, time code, and shot data can be superimposed on the image on the monitor. Like the VIDEO OUT connector, this connector can also be used to synchronize the time code of an external VTR with the time code of the camcorder.

For details on how to select the test output signal, refer to the Maintenance Manual.

27 i.LINK (i.LINK) DV IN/OUT S400 connector (6-pin, IEEE1394 compliant)

Connect to a device supporting the DV format or a computer, using a i.LINK cable.

Notes

- If video and audio signals are not output to an external device connected to the i.LINK DV IN/OUT S400 connector, try disconnecting the i.LINK cable and then reconnecting it, making sure that it is firmly seated.
- When you connect this unit to an external device with a 6-pin i.LINK connector, always power this unit off and disconnect the DC cable from the DC IN connector, or remove the battery pack, before connecting or disconnecting the i.LINK cable. If you connect or disconnect the i.LINK cable while power is being supplied to this unit, high voltage (8 to 40 V) can flow into this unit from the i.LINK connector of the connected equipment, possibly damaging this unit.
- When you connect this unit to an external device with a 6-pin i.LINK connector, always connect the 6-pin i.LINK connector on the external device first.

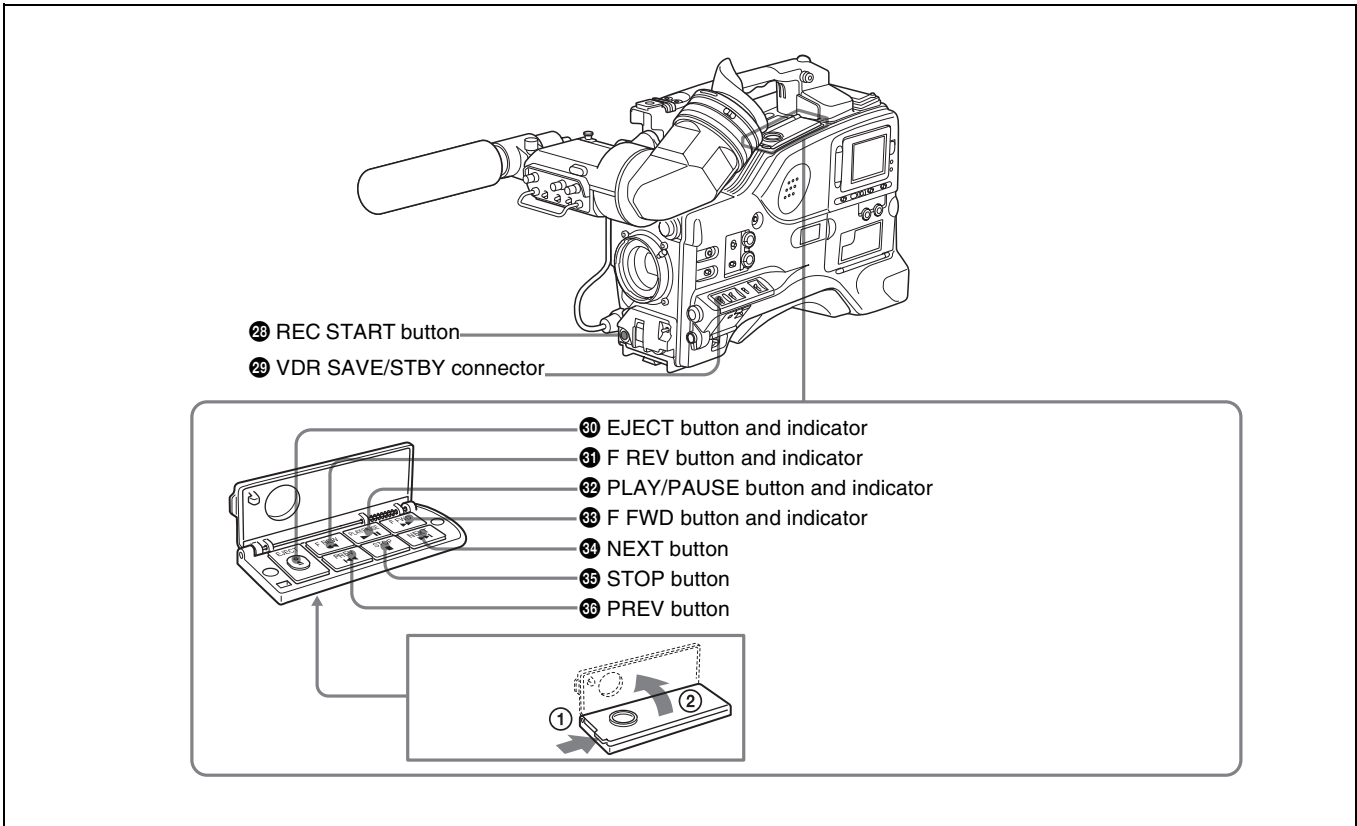

Shooting and recording/playback functions (4)

28 REC START button

Press this button to start recording. Press it again to stop recording. The effect is exactly the same as that of the VTR button on the lens.

When the REC SWITCH function is assigned to the ASSIGN 1, 3 or 4 switch (push button), you can use the switch as the REC START button.

29 VDR SAVE/STBY (standby) switch

This switch controls the VDR power mode during pauses in recording.

SAVE: Power saving mode. Although an internal operating sound is recorded as noise when you start recording, power consumption in this mode is less than in standby mode, so that battery life is extended. When the switch is set to SAVE, the SAVE indicator in the viewfinder lights.

STBY: Standby mode. Recording starts as soon as you press the REC START button.

30 EJECT button and indicator

Press this button to eject or load a disc. The indicator flashes while the disc is being ejected.

31 F REV (fast reverse) button and indicator

Plays back at high speed in the reverse direction. The indicator lights during high-speed playback in the reverse direction.

32 PLAY/PAUSE button and indicator

Press this to view a playback image using the viewfinder screen or a color video monitor. The indicator lights during playback.

During playback, pressing this button pauses the playback, showing a still image. At this time, the indicator flashes. This camcorder is capable of color-image search at approximately four-times normal playback speed, making it easy to check recorded material. To use the color-image search, press the F REV button or F FWD button during playback. When the buttons are pressed, the PLAY indicator and the F REV or F FWD indicator light.

33 F FWD (fast forward) button and indicator

Plays back at high speed in the forward direction. The indicator lights during high-speed playback in the forward direction.

34 NEXT button

This jumps to the beginning of the next clip, and pauses. During the jump, the F FWD indicator flashes. Pressing this button together with the F FWD button jumps to the last frame of the last clip recorded on the disc.

35 STOP button

Press this button to stop disc playback.



36 PREV button

This jumps to the beginning of the current clip, and pauses. During the jump, the F REV indicator flashes. Pressing this button together with the F REV button jumps to the first frame of the first clip recorded on the disc.

2-5 Output Video Operating Section

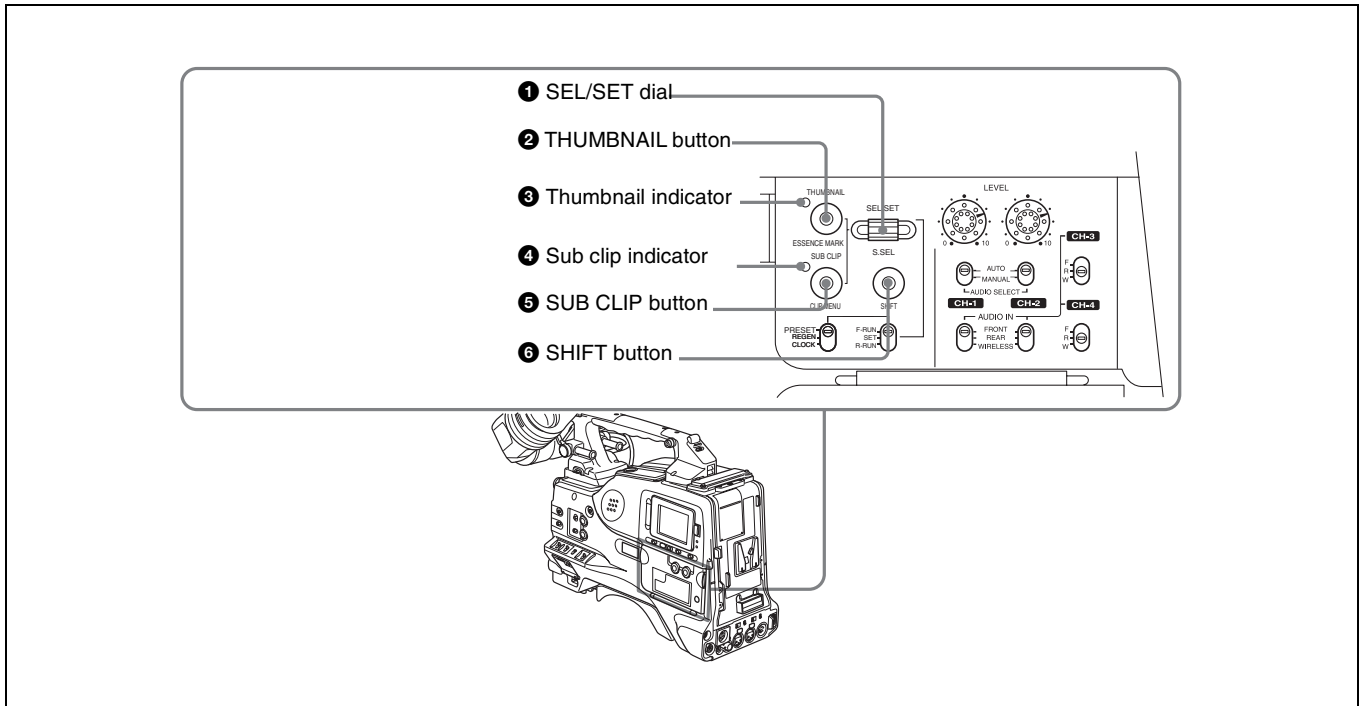

Output video operating section

❶ SEL/SET (select/set) dial

When thumbnails (each representing a clip) are shown on the color LCD, you can select a particular thumbnail with this dial.

Turning the dial upward moves the cursor to the left, and when it reaches the left edge, to the rightmost position in the row above. Turning the dial downward moves the cursor to the right, and when it reaches the right edge, to the leftmost position in the row below. After selecting the desired thumbnail with the cursor, press the dial in to confirm.

To carry out a scene selection setting, hold down the SHIFT button, and press in this dial.

❷ THUMBNAIL button

To carry out a search using thumbnails, or to create a clip list, press this button.

Pressing it switches from the whole-screen display to a thumbnail display. Press once more to return to the whole-screen display.

To search thumbnails by essence marks, hold down the SHIFT button and press this button.

❸ Thumbnail indicator

This lights when thumbnails are shown.

❹ Sub clip indicator

This lights when playing back following a clip list.

❺ SUB CLIP button

Press this to play back according to a clip list.

You can play back a particular clip or sequential clips, or carry out a search of the selected clip list.

When no clip list is selected, pressing this button has no effect, and the operation is invalid.

To carry out operations such as saving, recalling, or deleting a clip list, hold down the SHIFT button and press this button.

❻ SHIFT button

Use this in combination with other buttons.

2-6 Menu Operating Section

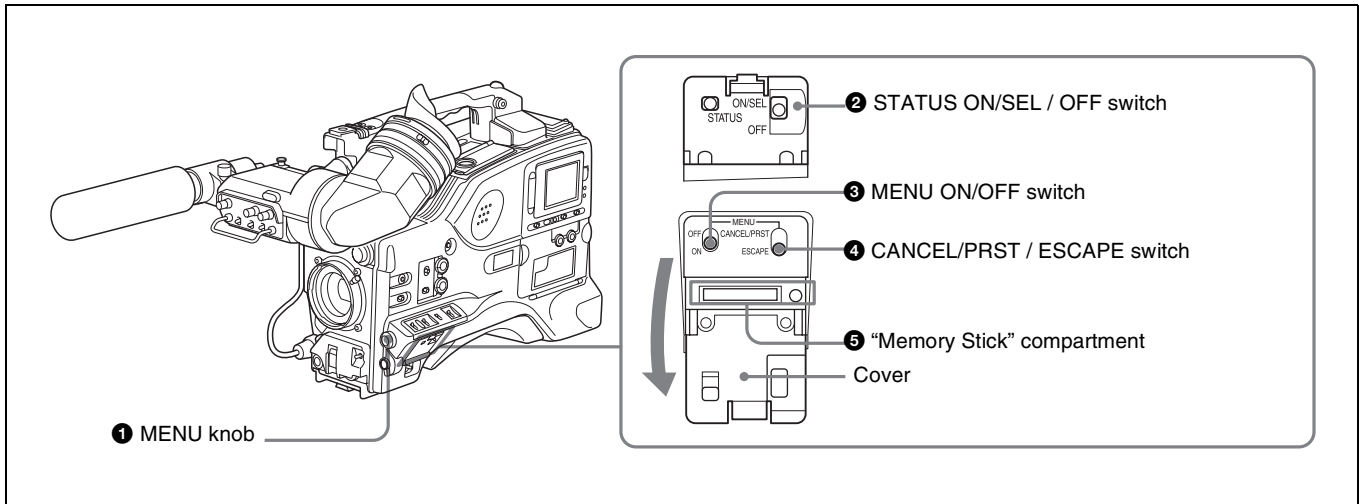

1 MENU knob

Use this knob to change the page selection or a setting within the menu.

Press: If you press this knob when the arrow (➡) is placed at the page title on the menu, the arrow changes to a question mark (?) and you can change the page by turning this knob.

When the arrow mark is placed at a position other than the page title, you can change the setting of the current item by pressing and turning this knob.

Turn: Turn this knob to change the page or change item settings.

2 STATUS ON/SEL / OFF (menu display on/page selection/display off) switch

To enable this switch, set the MENU ON/OFF switch to OFF.

Closing the cover automatically sets the MENU ON/OFF switch to OFF.

ON/SEL: Each time this switch is pushed upward, a window to confirm the menu settings and status of the camcorder appears on the viewfinder screen. The window consists of three pages, which are switched each time the switch is pushed upward. Each page is displayed for about 10 seconds.

OFF: To clear the page immediately after display, push this switch down to the OFF position.

You can select the pages to be displayed on the menu.

For details, see 7-2-8 "Displaying the Status Confirmation Windows" on page 114.

3 MENU ON/OFF switch

To use this switch, open the cover.

This switch is used to display the menu on the viewfinder screen or the test signal screen.

Closing the cover automatically sets this switch to OFF.

ON: Displays the menu on the viewfinder screen or the test signal screen, at the last accessed page. When the menu is used for the first time, the first page is displayed.

OFF: Removes the menu from the viewfinder screen or the test signal screen.

4 CANCEL/PRST (preset) / ESCAPE switch

To enable this switch, set the MENU ON/OFF switch to ON.

Closing the cover automatically sets the MENU ON/OFF switch to OFF.

CANCEL/PRST: Pushing this switch up to this position displays the message to confirm whether the previous settings are cancelled or settings are reset to their initial values, depending on the menu operating condition.

Pushing this switch up to this position again cancels the previous settings or resets the settings to their initial values.

ESCAPE: Use this switch when the menu page, which has a hierarchical structure, is opened. Each time the switch is pushed to this position, the page returns to one stage higher in the hierarchy.

5 “Memory Stick” compartment

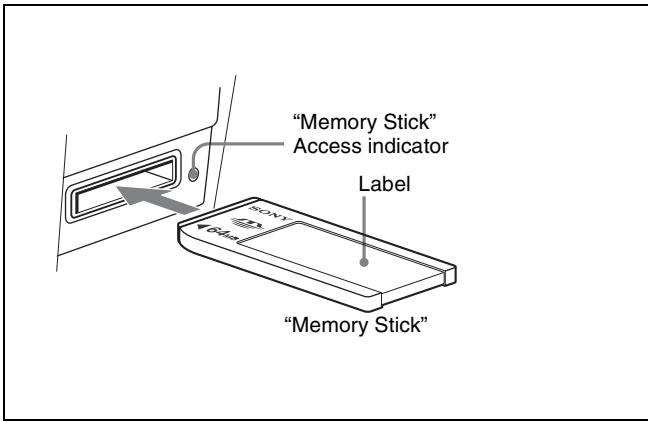

How to insert a “Memory Stick”

Open the lid of the menu operating section, and insert a “Memory Stick”, with the notch facing downward, in the direction shown by the arrow, so that it clicks into place. To remove a “Memory Stick”, first press it in to release the lock, then withdraw.

The “Memory Stick” access indicator lights when the “Memory Stick” is being accessed (for reading or writing).

For details about types of “Memory Stick”, see “About a “Memory Stick”” on page 193.

Notes

- Do not insert/remove a “Memory Stick” while the “Memory Stick” access indicator is lit or flashing. Doing so may cause a loss of data.
- This device uses a standard “Memory Stick” and a “MagicGate Memory Stick” equipped with MagicGate copyright protection technology. It is not possible to use a “Memory Stick PRO”.

2-7 Time Code System

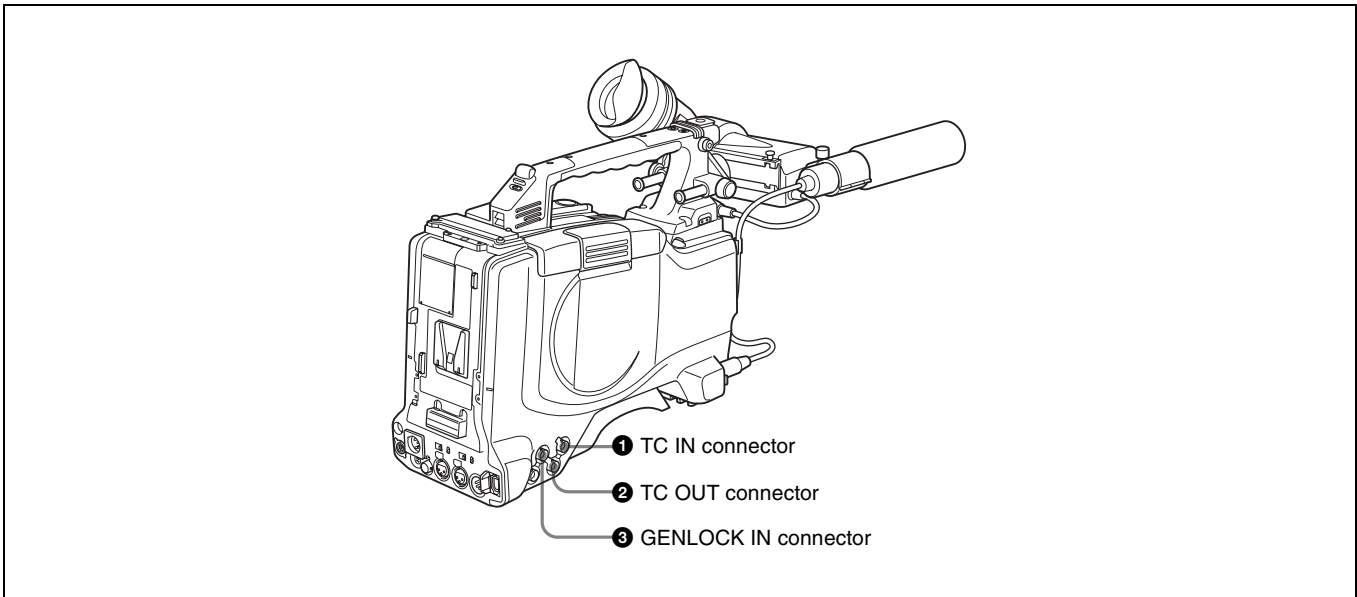

Time code functions (1)

1 TC IN (time code input) connector (BNC type)

To synchronize the time code of this unit to an external time code, input the reference time code to this connector.

2 TC OUT (time code output) connector (BNC type)

To synchronize the time code of an external VTR to that of the camcorder, connect this connector to the reference time code input connector of the external VTR.

3 GENLOCK IN connector (BNC type)

- This connector inputs a reference signal when the camera is to be genlocked or when the time code is to be synchronized with external equipment. Use the MAINTENANCE menu to adjust the genlock H-phase (phase of horizontal sync signal) and the sub-carrier phase.

For details, refer to the Maintenance Manual.

- This connector also inputs a return video signal. You can display the return video signal in the viewfinder screen while holding the RET button down with “RETURN VIDEO” set to “ON” on the GENLOCK page of the OPERATION menu.
- This connector also inputs an external analog composite video signal. When the CBK-SC01 extension board is installed, you can record the external analog composite video signal input to this connector.

For details, see 3-4 “Recording Video Signals from External Equipment” on page 58.

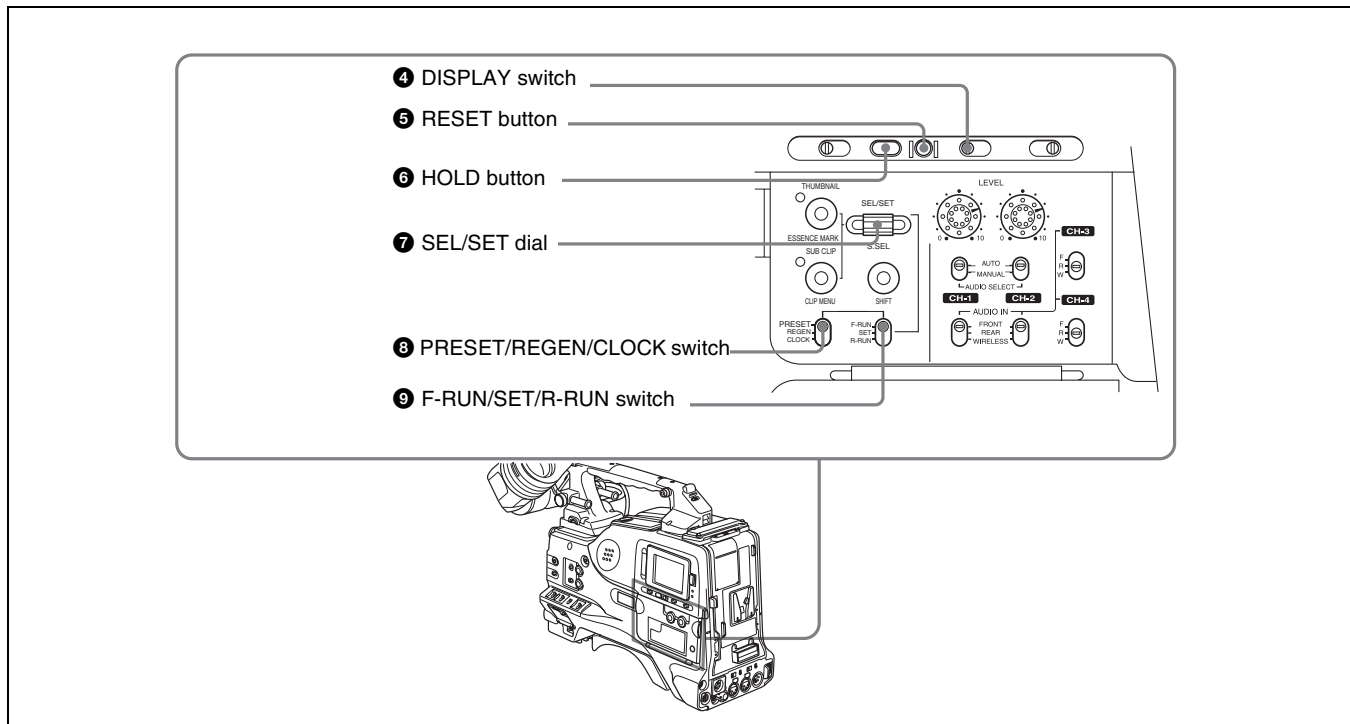

Time code functions (2)

4 DISPLAY switch

This cycles the data displayed in the counter display through the sequence COUNTER, TC, and U-BIT.

COUNTER: Display the elapsed recording/playback time (hours, minutes, seconds, frames).

TC: Display time code.

U-BIT: Display user bit data.

For details, see “Time code display” on page 35.

5 RESET button

Pressing this button resets the time data displayed on the counter display section to “00:00:00:00” or the user bit data to “00000000.”

6 HOLD (display hold) button

Pressing this button instantly freezes the time data displayed in the counter display section. (The time code generator continues running.) Pressing this button again releases the hold. You can use this button, for example, to determine the exact time of a particular shot.

When the HOLD button is activated, the time data is displayed in the following format:

00:00:00:00

For details of the counter display, see 2-9 “Warnings and Indications on the LCDs” on page 33.

7 SEL/SET (select/set) dial

To set a time code, user bit, or real time value, press this dial so that the digit you want to change flashes.

Turning the dial upward increases the value of the flashing digit, and turning it downward decreases the value.

8 PRESET/REGEN (regeneration)/CLOCK switch

This switch selects whether to set a new time code or to follow the already recorded time code.

PRESET: Records time code with a preset initial value.

REGEN: Records time code continuous with the existing time code recorded on the disc. Regardless of the setting of the F-RUN/SET/R-RUN switch, the camcorder operates in R-RUN mode.

CLOCK: Records time code synchronized to the internal clock. Regardless of the setting of the F-RUN/SET/R-RUN switch, the camcorder operates in F-RUN mode.

9 F-RUN/SET/R-RUN (free run/set/recording run) switch

This switch selects the operating mode for the internal time code generator.

F-RUN: Time code keeps advancing, regardless of the operating state of the VDR. Use this setting when aligning the time code with real time or when synchronizing the time code with an external time code.

SET: Set the switch to this position to set the time code or user bits.

R-RUN: The time code value advances only during recording. Use this setting to have a consecutive time code on the disc.

For details, see 5-6-3 “Setting the User Bits” on page 84 and 5-6-1 “Setting the Time Code” on page 84.

2-8 Warnings and Indications

Besides the viewfinder, speaker and earphones, the indicators and displays described in this section also

provide you with information such as the operating state of the camcorder and warnings.

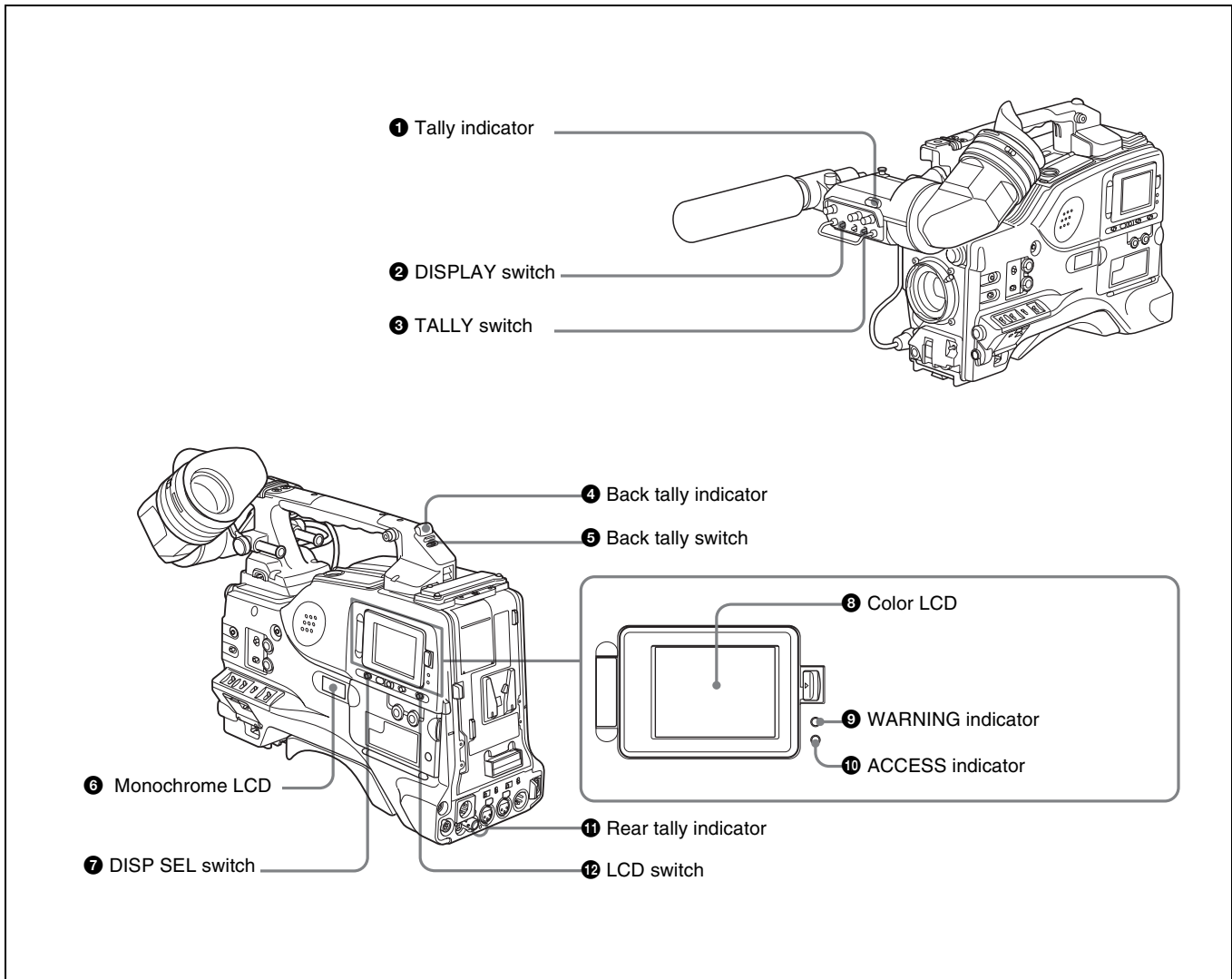

Warning and indication functions

1 Tally indicator

Setting the TALLY switch on the viewfinder to HIGH or LOW enables this indicator. It lights when the VDR starts recording. Like the REC indicator in the viewfinder, it also flashes to provide warnings. The brightness of this indicator when it is lit can be switched with the TALLY switch.

2 DISPLAY switch

This switches the indications on the viewfinder screen on or off.

ON: The indications appear on the viewfinder screen.

OFF: The indications do not appear on the viewfinder screen.

Note

Setting the MENU ON/OFF switch to ON displays the menu on the viewfinder screen even if the DISPLAY switch is set to OFF.

3 TALLY switch

This switch controls the tally indicator as follows.

HIGH: The tally indicator brightness is high.

OFF: The tally indicator is disabled.

LOW: The tally indicator brightness is low.

4 Back tally indicator

When the back tally switch is set to ON, this indicator has the same function as the tally indicator.

5 Back tally switch

This switch enables or disables the back tally and rear tally indicators.

ON: The back tally and rear tally indicators are enabled.

OFF: The back tally and rear tally indicators are disabled.

6 Monochrome LCD

This shows the remaining battery capacity, remaining disc capacity, time data, and so on.

For details, see 2-9-1 “Monochrome LCD” on page 33.

7 DISP SEL (display selection) switch

This switches the display in the color LCD.

CHAR: Display video with superimposed text. With the MENU ON/OFF switch set to OFF, also display camcorder status indications similar to those displayed in the viewfinder (*see 7-2 “Status Display on the Viewfinder Screen” on page 107*).

MONI: Display video without superimposed text.

STATUS: Display counter, warnings, and audio levels.

8 Color LCD

This displays VDR-related warnings, remaining battery capacity, remaining disc capacity, audio levels, time data, and so on.

For details, see 2-9-2 “Color LCD” on page 34.

9 WARNING indicator

This indicator lights up or flashes when there is a fault in the VDR.

For details, see 10-3 “Operation Warnings” on page 162.

10 ACCESS indicator

This lights when data is written to or read from the disc.

11 Rear tally indicator

When the back tally switch is set to ON, this indicator has the same function as the tally indicator.

12 LCD switch

This controls the backlights of the color LCD and the monochrome LCD.

OFF: The color LCD is turned off (the backlight of the monochrome LCD is off).

L: The color LCD is adjusted for viewing indoors (the backlight of the monochrome LCD is on).

H: The color LCD is adjusted for viewing outdoors (the backlight of the monochrome LCD is on).

2-9 Warnings and Indications on the LCDs

2-9-1 Monochrome LCD

Disc status and battery status

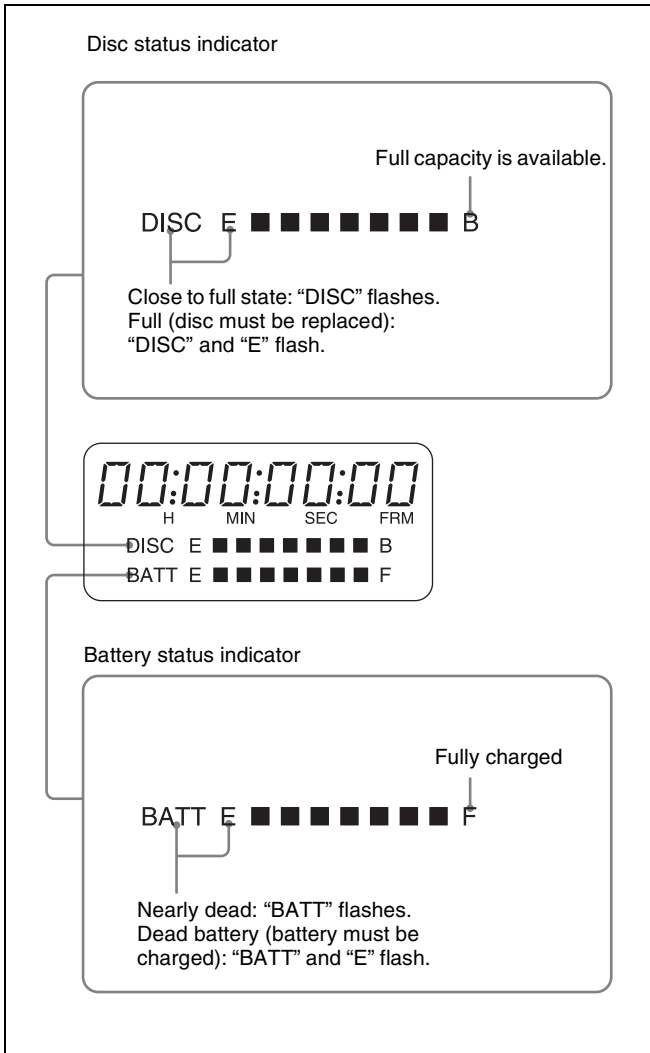

Display of remaining disc capacity and remaining battery capacity on the monochrome LCD

Time code display

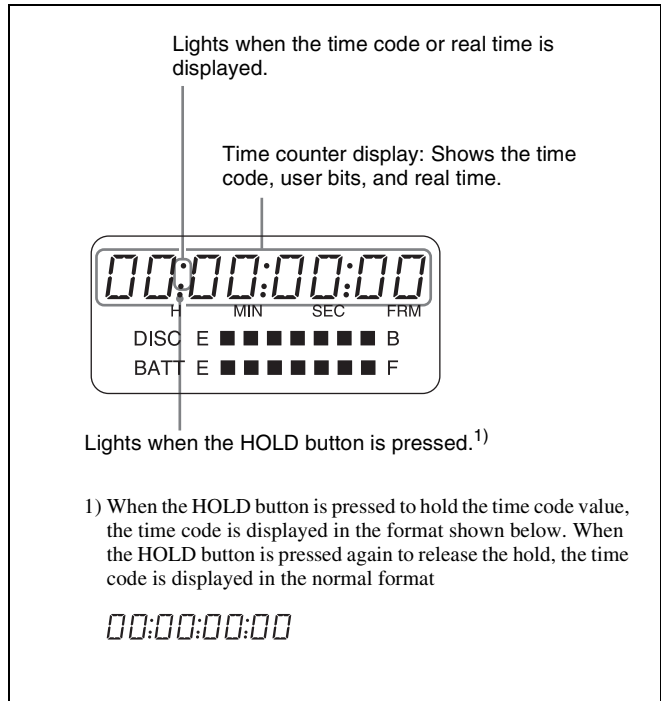

Time code display on the monochrome LCD

2-9-2 Color LCD

Disc status, battery status and audio level

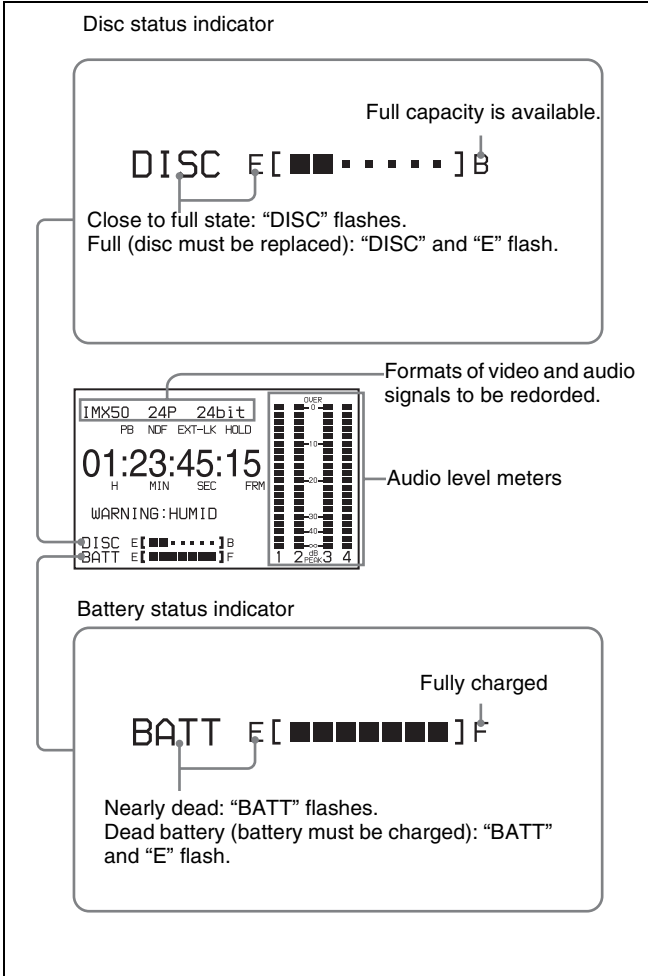

Display of remaining disc capacity, remaining battery capacity, and audio levels on the color LCD

VDR operation status and status indicators

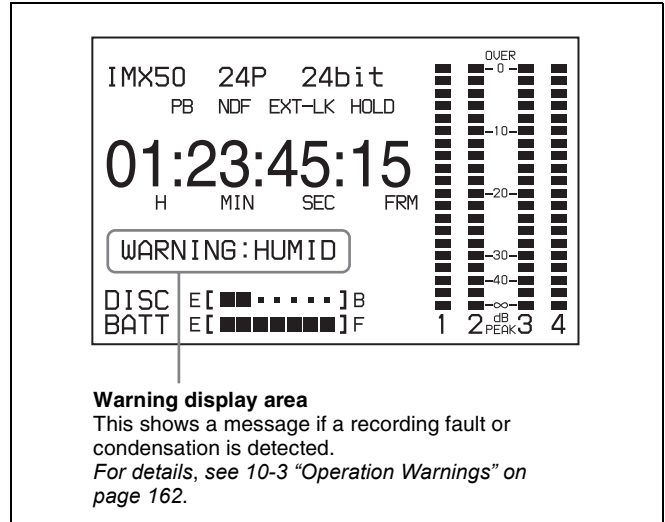

VDR operation and status indicators on the color LCD

Time code display

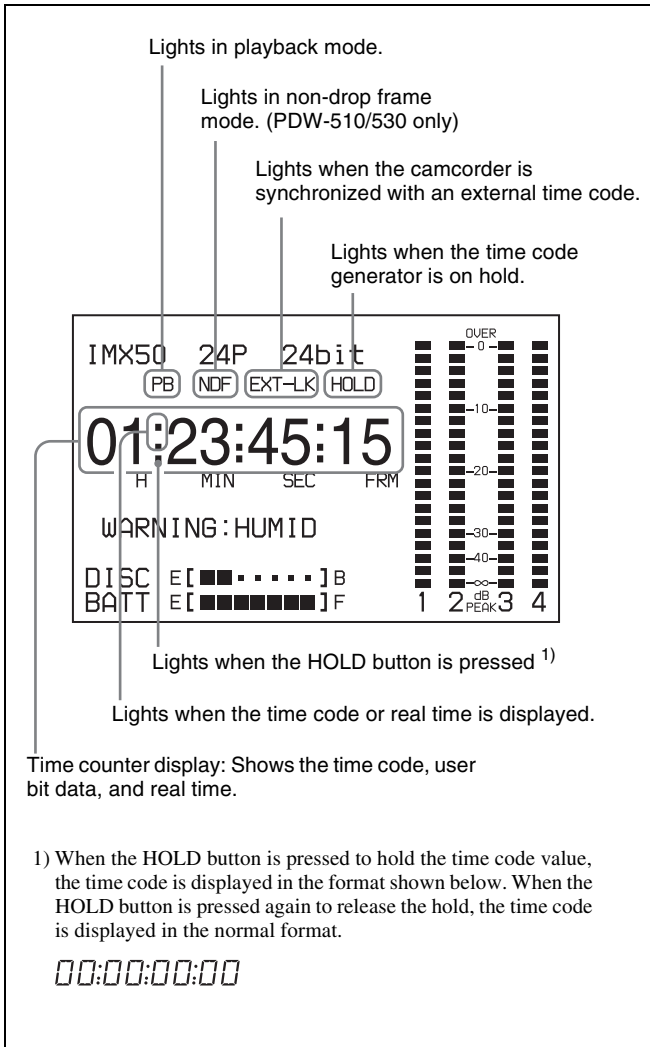

Time code display on the color LCD

2-10 Indicators in the Viewfinder

Several indicators are provided above and below the viewfinder screen to indicate the current state and adjustments of the camera.

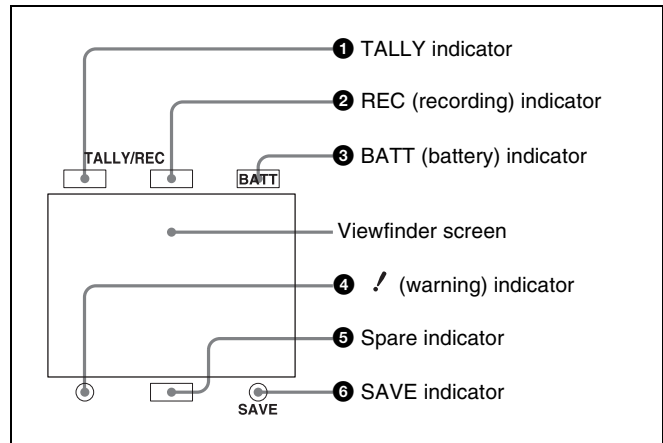

Indicators on the viewfinder

1 TALLY (green tally) indicator

This indicator lights when the camcorder is in Picture Cash mode. Also, this indicator lights when a green tally signal is received from the camera control unit.

2 REC (recording, red tally) indicator

This indicator lights red when recording starts and remains lit during recording. It also lights when a red tally signal is received from the camera control unit and flashes to give a warning.

For details, see 10-3 “Operation Warnings” on page 162.

3 BATT (battery) indicator

This indicator starts flashing when the battery connected to the camcorder is nearly exhausted, and stays lit when the battery is completely exhausted. The battery power level at which the indicator starts flashing can be set on the BATTERY 1 page of the MAINTENANCE menu.

For details, refer to the Maintenance Manual.

4 ! (warning) indicator

This indicator lights when any of the following conditions occurs with the corresponding item set to ON on the “!” LED page of the USER menu.

- The gain is set to other than 0 dB.
- The SHUTTER selector is set to ON (scan mode I).
- The shutter speed is set to a value other than 1/60 (scan mode PsF).

- The WHITE BAL switch is set to PRST.
- ATW is enabled.
- The lens extender is used.
- The FILTER selector is set to other than ND:1/CC:B.
- The reference value of auto iris adjustment is not the standard value.

⑤ Spare indicator

This is a spare indicator.

This can be used as a REC indicator by setting REC TALLY to BOTH in the FUNCTION 3 page of the MAINTENANCE menu.

⑥ SAVE indicator

This indicator lights when the VDR SAVE/STBY switch is set to SAVE, putting the VDR into power save mode.

3-1 Handling Discs

3-1-1 Discs Used for Recording and Playback

This camcorder uses the following disc for recording and playback:

PFD23 Professional Disc (capacity 23.3 GB)

Note

It is not possible to use the following discs for recording or playback:

- Blu-ray Disc
- Professional Disc for Data

3-1-2 Notes on Handling

Handling

The Professional Disc is housed in a cartridge, and is designed to allow handling free of risk from dust or fingerprints. However, if the cartridge is subjected to a severe shock, for example by dropping it, this can result in damage or scratching of the disc. If the disc is scratched, it may be impossible to record video/audio, or to play back the content recorded on the disc. The discs should be handled and stored carefully.

- Do not touch the surface of the disc itself within the cartridge.
- Deliberately opening the shutter may cause damage.
- Do not disassemble the cartridge.
- The supplied adhesive labels are recommended for indexing discs. Apply the label in the correct position.

Storage

- Do not store discs where they may be subjected to direct sunlight, or in other places where the temperature or humidity is high.

- Do not leave cartridges where dust may be able to gain ingress.
- Store cartridges in their cases.

Care of the discs

- Remove dust and dirt on the outside of a cartridge using a soft dry cloth.
- If condensation forms, allow ample time to dry before use.

3-1-3 Write-Protecting Discs

To protect the content recorded on the disc from accidental erasure, move the write-protect tab on the lower surface of the disc in the direction of the arrow, as shown in the following figure.

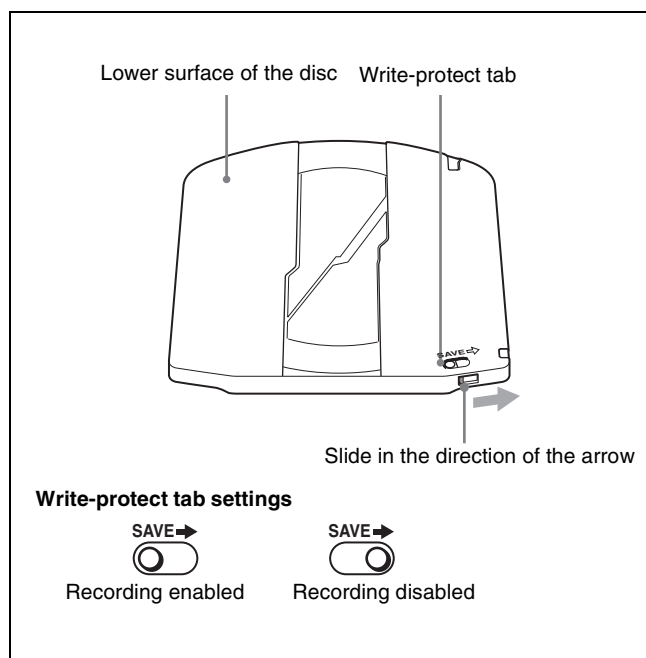

3-1-4 Loading and Unloading a Disc

Loading a disc

Proceed as follows.

- 1 Turn on the POWER switch.

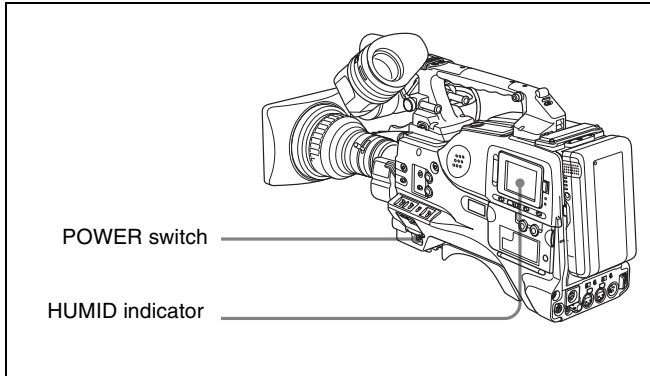

Note

If there is condensation inside the VDR section, the message “HUMID” appears in the viewfinder screen and the color LCD. If this happens, wait until the indicator goes off before going on to step 2.

- 2 Press the EJECT button.

This opens the lid of the disc compartment.

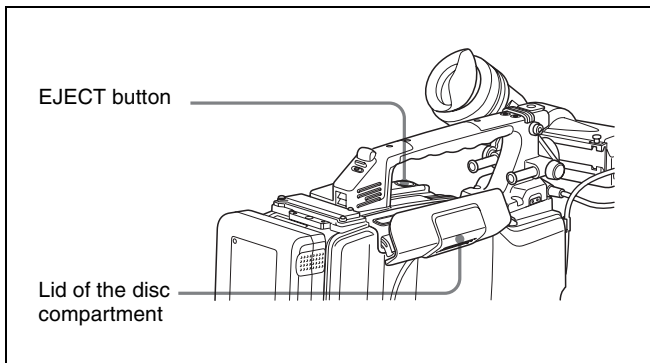

- 3 Insert the disc in the ▼ direction, and close the disc compartment lid manually.

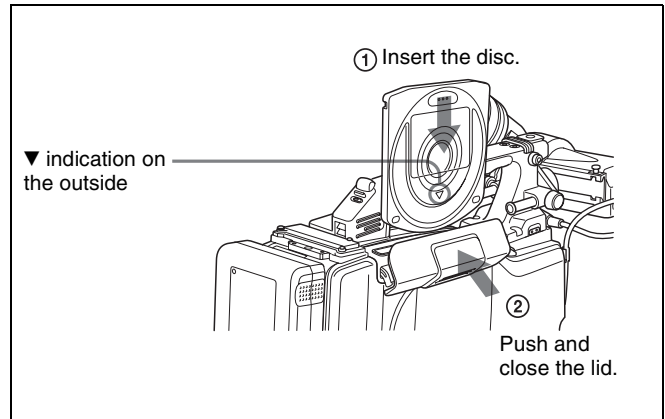

The disc is loaded.

Note

To insert the disc correctly, make sure that the camcorder is in the upright position (the grip upside, the bottom downside).

Unloading a disc

With the power supply on, press the EJECT button to open the disc compartment lid and eject the disc. Then remove the disc. If you are not going to insert another disc, close the disc compartment lid.

Unloading a disc when the power supply is off

If the battery is exhausted, it is not possible to remove the disc by pressing the EJECT button. In such cases, use the following emergency procedure to remove the disc manually.

- 1 Turn off the POWER switch.
- 2 Carry out the operation shown in the following figure.

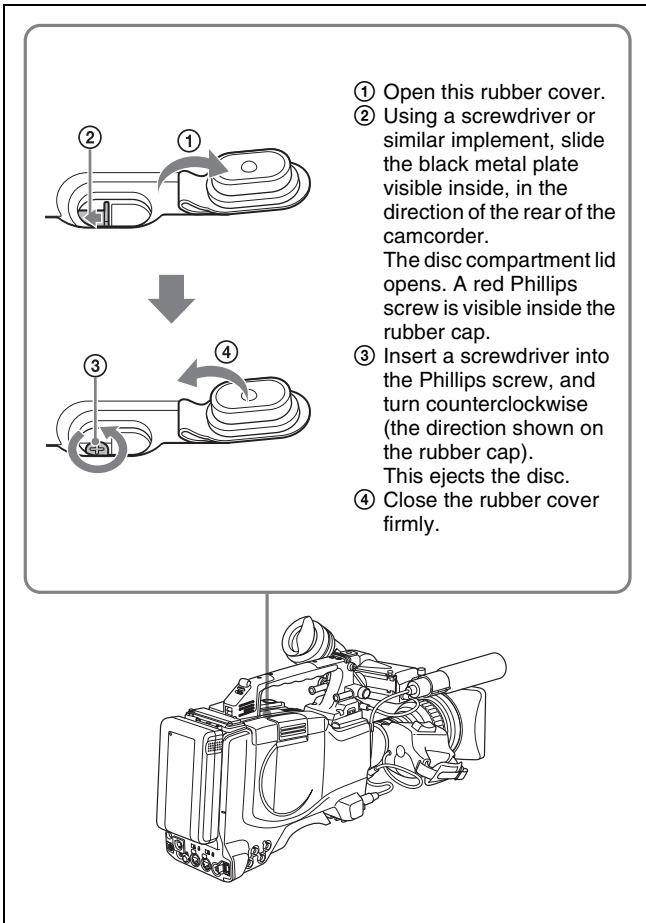

Unloading a disc manually when the power supply is off

You need not return the screw to its original position after taking out the disc. Turning on the power makes the disc compartment mechanism operable again.

3-1-5 Formatting a Disc

Using a new disc

An unused disc requires no formatting operation. The disc is automatically formatted so that it is ready to use when loaded into this unit.

Using a disc on which material is recorded

To format a recorded disc, load the disc into the unit then do as follows.

Note

When a recorded disc is formatted, all the data on the disc is erased.

- 1 Holding down the MENU knob, move the MENU ON/OFF switch from OFF to ON.

The TOP menu appears.

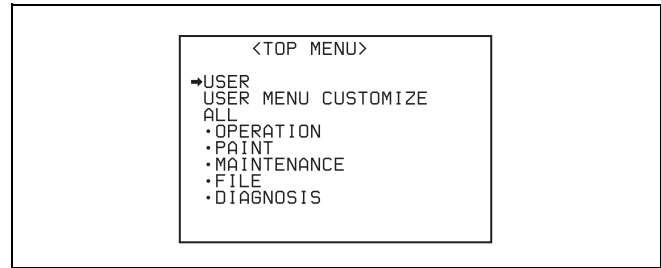

- 2 Turn the MENU knob to move the → mark to “MAINTENANCE”, and press the MENU knob.

If this is the first time the MAINTENANCE menu has been displayed, the CONTENTS page of the MAINTENANCE menu appears. If the menu has been used before, the last accessed page appears.

- 3 If the CONTENTS page is displayed, turn the MENU knob to move the → mark to “DISC”, and press the MENU knob to display the DISC page.

If a different page is displayed, turn the MENU knob until the DISC page appears, then press the MENU knob to select the page.

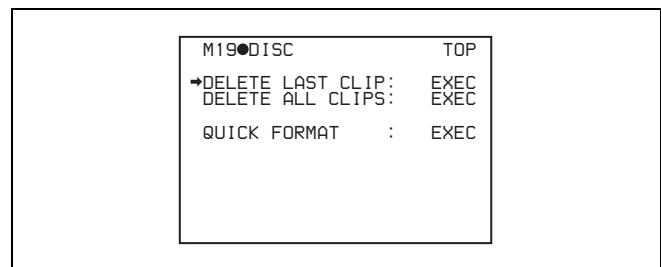

- 4 Press the MENU knob, then turn it to move the → mark to “QUICK FORMAT”, and press the MENU knob again.

The message “EXECUTE OK? YES → NO” appears.

- 5 Turn the MENU knob to move the → mark to “YES”, and press the MENU knob again.

Formatting is completed and the message “COMPLETE” appears.

3-1-6 Handling of Discs When Recording Does Not End Normally (Salvage Function)

Recording processing does not end normally if, for example, the battery pack is removed during recording, or if the power cord is disconnected during recording. Because the file system is not updated, video and audio data recorded in real time is not recognized as files and clip contents recorded up to that point are lost.

However, this unit has a salvage function which can hold losses to the minimum by reconstructing clips on such discs.

Note that no recorded clip contents are lost when the POWER switch is turned off and when battery exhaustion is detected, because the unit does not enter power saving mode until after the end of recording processing.

Notes

- Do not disconnect the battery pack or power cord until recording processing has finished and the ACCESS indicator has gone out.
 - This function salvages as much recorded material as possible after an unforeseen accident, but 100% restoration cannot be guaranteed.
 - Even when this function is used, it is not possible to recover data from immediately before the interruption of recording. The amount of data lost is as follows.
 - Quick salvage: From 2 to 4 seconds of data before the interruption of recording.
 - Full salvage: From 4 to 6 seconds of data before the interruption of recording.
- More data may be lost when functions such as Picture Cache and Interval Rec are being used.

Quick salvage

When the unit is powered on again after a recording interruption due to a power interruption, with the disc still loaded in the unit, clips are reconstructed on the basis of backup data stored in nonvolatile memory and markers recorded on the disc.

Processing time is about 5 seconds.

Full salvage

When recording on an XDCAM device is interrupted because of a power interruption, and a disc is manually ejected from that device with the power off, clips are reconstructed on the basis of markers recorded on the disc when the disc is loaded in this unit. Therefore, processing takes longer than for a quick salvage (about 30 seconds, although it depends on the state of the disc).

Proceed as follows to perform a full salvage.

- 1 Insert the disc on which recording did not end normally.

The following salvage message appears.

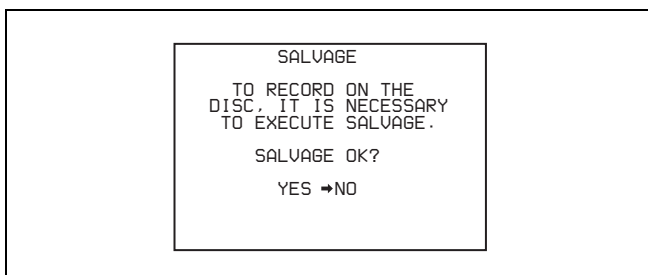

- 2 Turn the MENU knob to move the → mark to YES, then press the MENU knob.

Salvage processing starts, and the message “EXECUTING.” appears.

A results message appears when the processing finishes.

- If the salvage succeeded, the message “COMPLETED.” appears.
- If the salvage failed, the message “INCOMPLETED.” appears. Clips for which recording did not end normally are lost.

To exit without salvaging

Select NO in step 2 to exit without performing salvage processing.

However, the status of the disc does not change. Salvage is still required to recover the clips for which recording did not end normally. The salvage message will appear again when that disc is inserted again, or when the camcorder is powered on again.

Note

If salvage processing is not done, sections which were recorded normally can be played back, but no new recording can be done on the disc.

3-2 Recording

3-2-1 Basic Procedures

This section describes the basic procedures for shooting and recording.

Before a shooting session, ensure that the camcorder is functioning properly.

For details, see 10-1 “Testing the Camcorder Before Shooting” on page 157.

Recording format settings (PDW-530/530P only)

With the PDW-530/530P you can select the recording formats for each of video and audio.

Note that it is not possible to use different recording formats on a single disc.

Be sure to select the same format as the existing recording if you use a disc on which material is recorded, or otherwise use a different disc.

For details of the setting operations, see 5-1-1 “Setting the Video Recording Format” on page 70 and see 5-1-2 “Setting the Audio Recording Format” on page 71.

Thumbnail image setting

As required, you can select the frame to display as the thumbnail image of a clip.

(The factory default setting is to display the first frame in the clip as the thumbnail image.)

See 5-7 “Setting the Thumbnail Image” on page 87 for more information about how to make this setting.

Basic procedure for shooting: from turning on the camcorder to loading a disc

Proceed as follows.

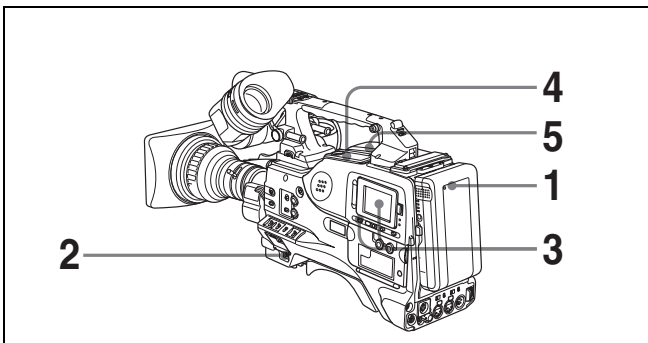

Basic procedure for shooting: from power supply to disc loading

- 1 Attach a fully charged battery pack.

For details, see 9-1 “Power Supply” on page 142.

- 2 Turn on the POWER switch.

- 3 Set the DISP SEL switch to STATUS, and check on the color LCD that the following conditions are met.

- The HUMID indicator is not showing. If it is, wait until it disappears.
- The battery status indicator (■) shows at least five segments. If it does not, replace the battery pack with a fully charged one.

- 4 Check that there are no obstructions such as cables near the disc compartment lid. Then press the EJECT button to open the disc compartment lid.

- 5 After checking that the disc is not write-protected (see page 37), load it and close the disc compartment lid.

Basic procedure for shooting: from adjusting the black balance and white balance to stopping recording

Switch settings

After turning on the power and loading a disc, set the switches and selectors as shown below and begin operation.

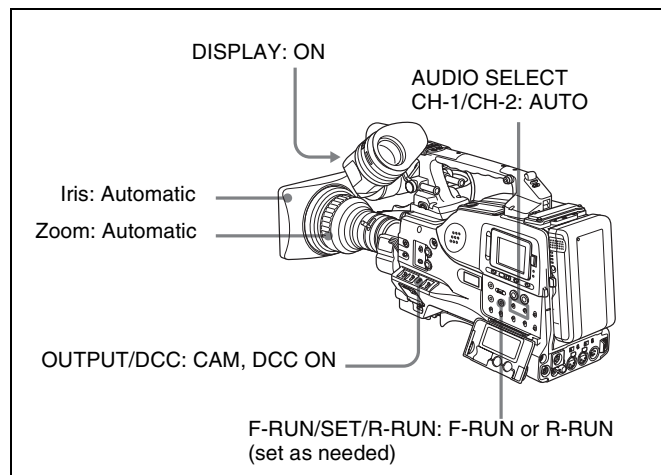

Switch and selector settings before shooting

Shooting

Proceed as follows.

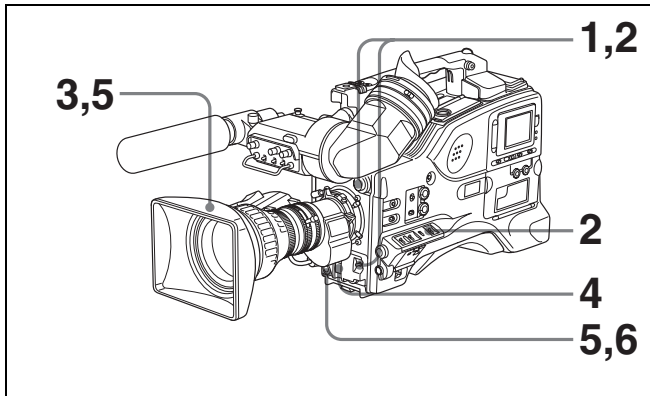

Basic procedure for shooting: from adjusting the black balance and white balance to stopping recording

- 1 Push the AUTO W/B BAL switch to BLK to adjust the black balance.

For details of black balance adjustment, see 5-2-1 “Adjusting the Black Balance” on page 72.

- 2 Select the CC filter and ND filter to match the lighting conditions, and adjust the white balance.

When the white balance settings are already in memory

Set the WHITE BAL switch to A or B.

When the white balance setting is not in memory and you do not have enough time to adjust the white balance

Set the WHITE BAL switch to PRST.

This automatically adjusts the white balance as follows, depending on the setting of the FILTER knob.

- For the PDW-530/530P:
B: 3200 K, C: 4300 K, D: 6300 K
- For the PDW-510/510P:
1: 3200 K, 3: 5600 K

For details, see 5-2-2 “Adjusting the White Balance” on page 73.

- 3 Aim the camera at the subject and adjust the focus and zoom.
- 4 If necessary, set the electronic shutter for an appropriate mode and speed.

For details, see 5-3 “Setting the Electronic Shutter” on page 76.

- 5 To start recording, press the REC START button or the VTR button on the lens.

If the recording start/stop function is assigned to the ASSIGN 1/3/4 switch, this switch functions as REC START button.

For details, see 7-3-5 “Assigning Functions to ASSIGN 1/2/3/4 Switches” on page 120.

During recording, the REC indicator lights in the viewfinder. Perform zooming and focus control, if necessary.

Note

During recording (while the ACCESS indicator is lit) do not remove the battery pack. If you do, the internal processing for recording may not finish properly, which may cause the last few seconds of recording to be lost.

For details, see 3-1-6 “Handling of Discs When Recording Does Not End Normally (Salvage Function)” (page 39).

- 6 To stop recording, press the REC START button or the VTR button on the lens again.

The REC indicator in the viewfinder goes off. The material recorded from step 5 to step 6 is saved as a single clip.

To play back the recorded clip

Press the PREV button, then press the PLAY/PAUSE button to play from the beginning of the clip.

- 7 Repeat steps 5 and 6 as required for shooting.

Each time you repeat steps 5 and 6, successive clips are recorded on the disc.

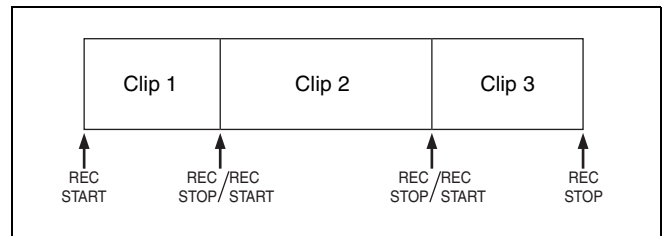

Notes

- It is not possible to record a clip shorter than 2 seconds. If you stop recording within 2 seconds of starting, this results in a 2-second clip. If you stop recording and restart within 2 seconds of the original start, this creates a single continuous clip from the original start time.
- The maximum number of clips that can be recorded on a single disc is 300. If an attempt is made to record more than 300 clips, the error message “DISC FULL!” appears, even if there is free capacity on the disc.

Playback control buttons

During recording, the playback control buttons (EJECT, F REV, F FWD, NEXT, PREV, PLAY/PAUSE, STOP) have no effect.

3-2-2 Deleting Clips

With this camcorder you can delete clips one at a time, in sequence from the last recorded clip, or you can delete all clips in a single operation.

To delete the last recorded clip

Proceed as follows.

- 1 Holding down the MENU knob, move the MENU ON/OFF switch from OFF to ON.

The TOP menu appears.

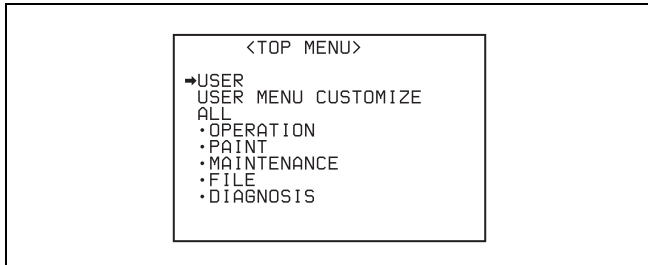

- 2 Turn the MENU knob to move the → mark to “MAINTENANCE”, and press the MENU knob.

If this is the first time the MAINTENANCE menu has been displayed, the CONTENTS page of the menu appears. If the menu has been used before, the last accessed page appears.

- 3 If the CONTENTS page is displayed, turn the MENU knob to move the → mark to “DISC”, and press the MENU knob.

If a different page is displayed, turn the MENU knob until the DISC page appears, then press the MENU knob to select the page.

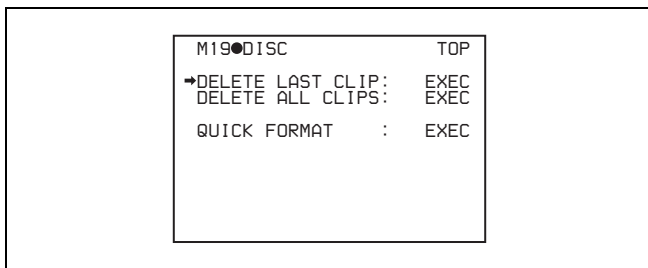

- 4 Press the MENU knob, then turn it to move the → mark to “DELETE LAST CLIP”, and press the MENU knob again.

The message “EXECUTE OK? YES → NO” appears.

- 5 Turn the MENU knob to move the → mark to “YES”, and press the MENU knob again.

The last recorded clip is deleted.

- 6 By repeating steps 4 and 5, you can delete a number of clips in sequence from the last recorded clip.

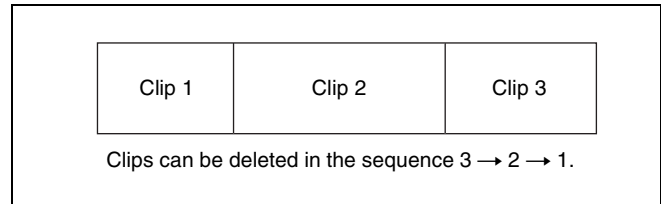

To delete all clips within the disc

Proceed as follows.

- 1 On the DISC page (see the previous item), move the → mark to “DELETE ALL CLIPS”, and press the MENU knob.

The message “EXECUTE OK? YES → NO” appears.

- 2 To execute deleting, turn the MENU knob to move the → mark to “YES”, and press the MENU knob.

This deletes all clips within the disc.

3-2-3 Recording Essence Marks

Shot marks and other essence marks can be recorded on the disc.

Recording essence marks for scenes containing important images and sounds enables quick access to the marked points. This increases editing efficiency. Some essence marks are recorded automatically, for example when recording starts and when the flash operates. Others are recorded manually.

To specify essence marks to be recorded on the disc

Proceed as follows.

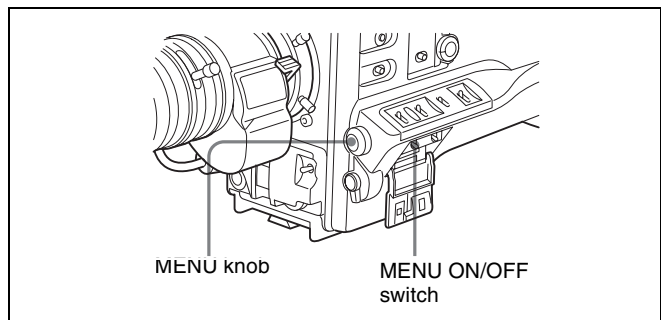

- 1 Holding down the MENU knob, move the MENU ON/OFF switch from OFF to ON.

The TOP menu appears.

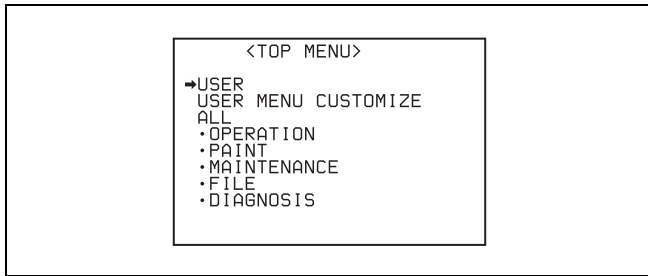

2 Turn the MENU knob to move the ➔ mark to “MAINTENANCE”.

3 Press the MENU knob.

If this is the first time the MAINTENANCE menu has been displayed, the CONTENTS page of the menu appears. If the menu has been used before, the last accessed page appears.

4 If the CONTENTS page is displayed, turn the MENU knob to move the ➔ mark to “ESSENCE MARK”, then press the MENU knob.

If a different page is displayed, turn the MENU knob until the ESSENCE page appears, then press the MENU knob to select the page.

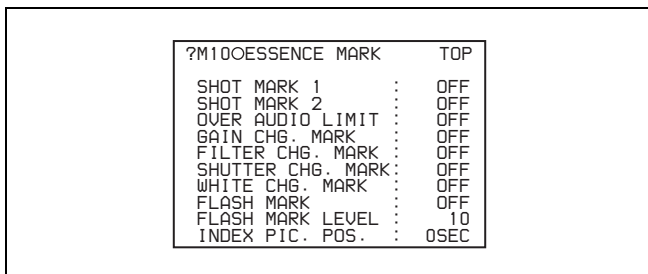

The items show the following types of essence marks.

SHOT MARK 1/2: Recorded manually.

OVER AUDIO LIMIT: Recorded when the audio level exceeds 0 dBFS.

GAIN CHG. MARK: Recorded when the gain value is changed.

FILTER CHG. MARK: Recorded when the filter is changed.

SHUTTER CHG. MARK: Recorded when the shutter speed is changed.

WHITE CHG. MARK: Recorded when the white balance is changed.

FLASH MARK: Recorded when a sudden brightness change occurs as when the flash operates or when the camcorder in recording mode is suddenly moved into an indoor space from a bright outdoor space.

5 Turn the MENU knob to move the ➔ mark to “SHOT MARK 1”.

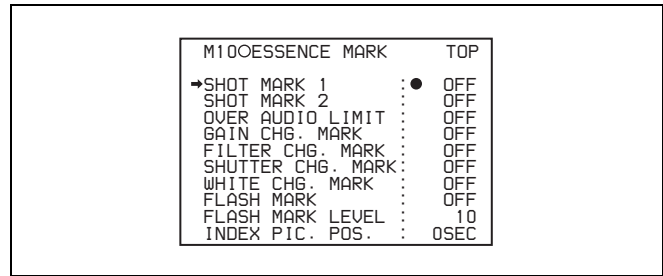

6 Press the MENU knob.

The ➔ mark to the left of “SHOT MARK 1” changes to a ● mark and the ● mark to the left of the setting changes to a ? mark.

7 If you want to record the essence mark, turn the MENU knob to display “ON”. If you do not want to record it, turn the MENU knob to display “OFF”.

8 Press the MENU knob.

9 Repeat steps **5** to **8** to set the remaining essence marks.

10 When FLASH MARK is “ON”, use the FLASH MARK LEVEL item to set the threshold brightness value (in the range 1 to 20) for essence mark recording.

11 Set the MENU ON/OFF switch to OFF to end the menu operation.

Recording a SHOT MARK 1 essence mark

Press the RET button once.

“ShotMark1” appears on the viewfinder screen for about one second near the time code display.

If SHOT MARK 1 recording has been assigned to one of the assignable switches, you can also use that switch to record a SHOT MARK 1 essence mark.

See section 7-3-5 “Assigning Functions to ASSIGN 1/2/3/4 Switches” (page 120) for more information about how to make assignments.

Recording a SHOT MARK 2 essence mark

Press the RET button twice in quick succession during recording or playback.

“ShotMark2” appears in the viewfinder screen for about one second near the time code display.

If SHOT MARK 2 recording has been assigned to one of the assignable switches, you can also use that switch to record a SHOT MARK 2 essence mark.

3-2-4 Starting a Shoot with a Few Seconds of Pre-Stored Picture Data (Picture Cache Function)

The camcorder has a large capacity internal memory, in which you can cache the last few seconds (maximum 12 seconds) of captured video and audio, so that recording starts from a point just before you press the REC START button or VTR button on the lens.

Setting the Picture Cache time/Picture Cache mode

To record in Picture Cache mode, you need to turn on Picture Cache mode and set the picture data storage time (Picture Cache time) using the USER menu.

The Picture Cache time determines the number of seconds recorded from the Picture Cache, counting back from the time when you press the REC START button or the VTR button on the lens to start recording. However, the number of seconds actually recorded from the Picture Cache may be shorter immediately after the setting of the VDR SAVE/STBY switch is changed, and in the special situations explained in the following notes.

Notes

- The contents of picture cache memory are unstable for a short time immediately after you select Picture Cache mode or change the Picture Cache time. Therefore, if you put the unit into recording mode by pressing the REC START button or the VTR button on the lens immediately after such operation, pictures just before such operation cannot be recorded. Also, a certain amount of time is required to actually start recording to a disc immediately after you insert a disc and when the VDR SAVE/STBY switch is set to SAVE. In these cases, the number of seconds that can actually be recorded from the picture cache may be fewer than the specified picture cache time.
- During playback or recording review, no data is saved to the picture cache memory. Thus it is not possible to use this function to rerecord the last few seconds of material from playback or recording review.

To turn Picture Cache mode on, proceed as follows.

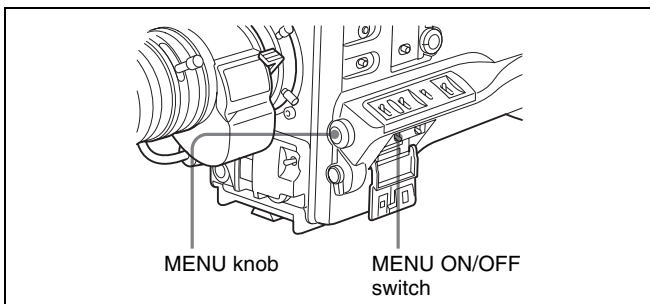

- 1 Set the MENU ON/OFF switch to ON.
The last accessed menu page appears on the screen.
- 2 Turn the MENU knob until the FUNCTION 1 page appears.

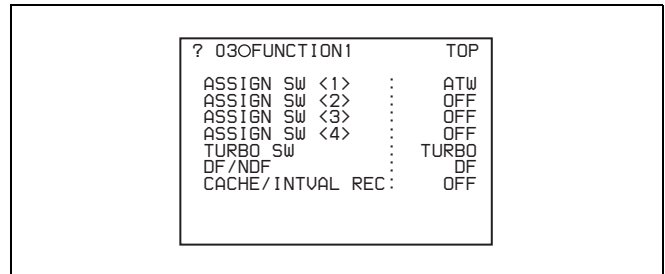

- 3 Press the MENU knob.
A \blacktriangleright mark appears on the left of the currently selected item and a \bullet mark appears on the left of the setting.

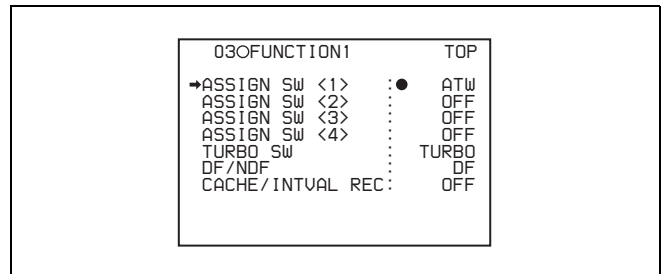

- 4 Turn the MENU knob to move the \blacktriangleright mark to "CACHE/INTVAL REC".
- 5 Press the MENU knob.
The \blacktriangleright mark on the left of "CACHE/INTVAL REC" changes to a \bullet mark and the \bullet mark on the left of the setting changes to a ? mark.

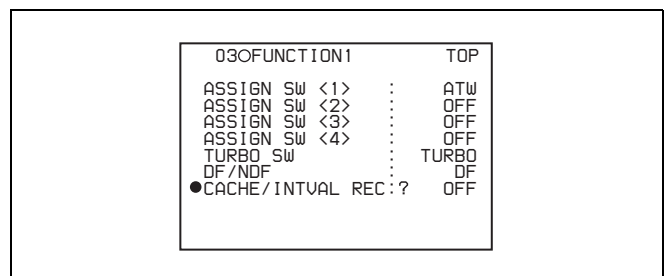

- 6 Turn the MENU knob until "CACHE" appears.
As you turn the MENU knob, the setting changes in the following sequence: OFF \leftrightarrow CACHE \leftrightarrow A. INT \leftrightarrow M. INT.
When "CACHE" appears, the camcorder is in Picture Cache mode, where picture, sound, and time code are constantly saved in memory. The TALLY indicator (green) is on while picture data is being stored in memory.

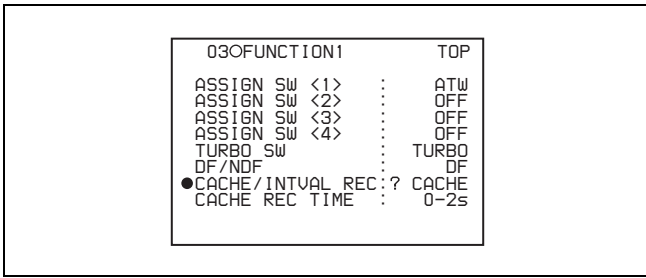

7 Press the MENU knob.

The ● mark changes to a ➔ mark and the ? mark changes to a ● mark.

8 Turn the MENU knob to move the ➔ mark to “CACHE REC TIME”.

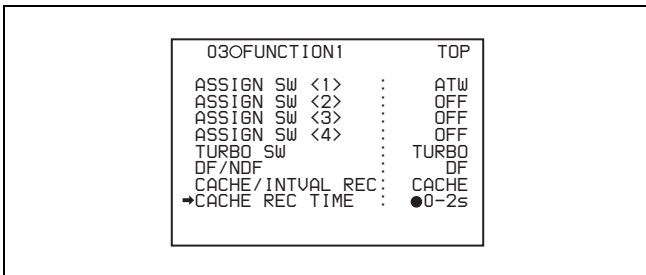

9 Press the MENU knob.

The ➔ mark on the left of “CACHE REC TIME” changes to a ● mark and the ● mark on the left of the setting changes to a ? mark.

10 Turn the MENU knob until the desired Picture Cache time appears.

As you turn the MENU knob, the Picture Cache time changes in the following sequence: 0-2s ↔ 2-4s ↔ 4-6s ↔ 6-8s ↔ 8-10s ↔ 10-12s.

11 Press the MENU knob.

The ● mark changes to a ➔ mark and the ? mark changes to a ● mark.

12 To end the menu operation, set the MENU ON/OFF switch to OFF.

The menu disappears, and the display indicating the current status of the camcorder appears along the top and bottom of the screen.

Settings made in Picture Cache mode are maintained until changed.

You can turn Picture Cache mode on and off by assigning the Picture Cache ON/OFF function to one of the assignable switches (ASSIGN 1/2/3/4 and TURBO GAIN buttons), and pressing the switch.

For detailed information on the ASSIGN 1/2/3/4 switches, see 7-3-5 “Assigning Functions to ASSIGN 1/2/3/4 Switches” on page 120.

Notes

- You can change the Picture Cache mode menu settings while recording; any changes that you make, however, do not take effect until after the recording operation is completed.
- In Picture Cache mode, the internal time code generator operating mode is always F-RUN regardless of the setting of the F-RUN/SET/R-RUN switch.

Camcorder operations in Picture Cache mode

The recording procedure in Picture Cache time is basically the same as that for normal recording. However, note the following differences.

- When you record in Picture Cache mode, the picture you are shooting now is recorded to disc after the picture data stored in memory (equal to the Picture Cache time) is recorded to disc. For this reason, disc access may continue for a short time after you press the REC START button to stop recording. During this time, the playback control buttons are disabled, as in recording mode. Also, if you press the REC START button or the VTR button on the lens to restart recording during this time, a separate clip is recorded.
- When you press the REC START button or the VTR button on the lens to restart recording during disc access, the start point of the recorded clip may be later than the Picture Cache time, especially when there are a large number of clips recorded on the disc. In Picture Cache mode, you should avoid stop and start recording operations in quick succession.
- The time disc access stops after the REC START button is pressed equals the Picture Cache time. However, if you start recording within the Picture Cache time immediately after selecting Picture Cache mode, changing the Picture Cache time or performing playback or recording review, the picture data for the duration of the Picture Cache time will not be stored in memory. Thus, the time disc access stops after the STOP button is pressed becomes shorter than the Picture Cache time.
- In Picture Cache mode, time code setting cannot be made by setting the F-RUN/SET/R-RUN switch to SET. To make time code settings, first exit Picture Cache mode.

When power is lost during recording

- When the power is turned off during recording, the camcorder will switch itself off after disc access has continued for a few seconds to record the picture in the instant of power off.
- If you remove the battery, pull out the DC cable, or cut power to the AC adaptor during recording, video and audio stored in memory will be lost without being recorded to the disc. For this reason, make sure you do not change the battery while recording.

3-2-5 Time-Lapse Video (Interval Rec Function)

Using the memory in the camcorder, you can capture time-lapse video. There are two modes for this function, which is known as “Interval Rec.”

• Auto Interval Rec mode

In Auto Interval Rec mode, pictures are automatically shot a frame at a time at the specified interval and stored in memory. To use this function you must set the total time for shooting (TAKE TOTAL TIME) and the length of time for recording on the disc (REC TIME).

• Manual Interval Rec mode

A specified number of frames (NUMBER OF FRAME) is recorded when you press the REC START button or the lens VTR button.

There are two Manual Interval Rec modes: a single shot mode in which recording is done once with each press of the button, and a consecutive mode in which recording is done repeatedly at a specified interval after the button is pressed.

A pre-lighting function is available in Auto Interval Rec mode and the consecutive mode of Manual Interval Rec mode. This function automatically turns on the light before recording starts, which allows you to record pictures under stable light and color temperature conditions.

Note

The camcorder cannot be put into Interval Rec mode when the scanning mode is 24P (with the CBK-FC01 expansion board (see page 125) installed).

Auto Interval Rec mode settings and shooting

To make settings before shooting

To record in Auto Interval Rec mode, you need to turn on Auto Interval Rec and set the total time from start to finish of shooting (TAKE TOTAL TIME) and the length of time for recording on the disc (REC TIME), using the USER menu.

Notes

- To make settings for Auto Interval Rec mode, set “TAKE TOTAL TIME” first, then “REC TIME”.
- To turn on the light automatically before starting to record, set the LIGHT switch to AUTO.

To turn on Auto Interval Rec mode, proceed as follows.

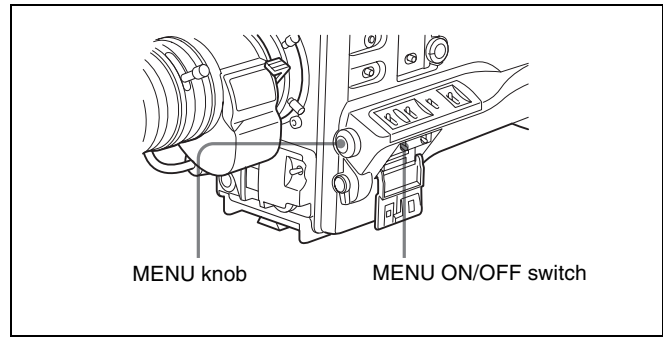

- 1 Set the MENU ON/OFF switch to ON.
The last accessed menu page appears on the screen.
- 2 Turn the MENU knob until the FUNCTION 1 page appears.

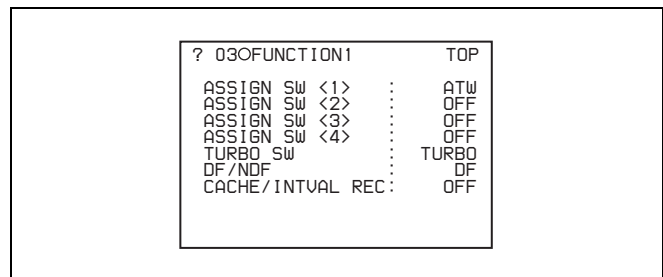

- 3 Press the MENU knob.

A ➔ mark appears on the left of the currently selected item and a ● mark appears on the left of the setting.

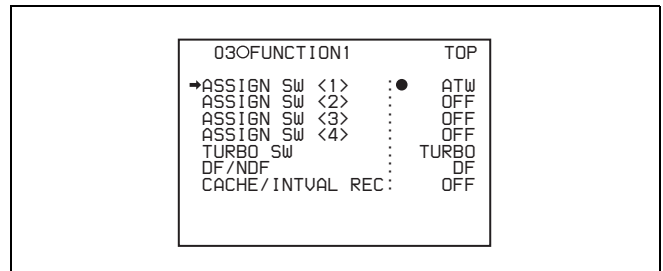

- 4 Turn the MENU knob to move the ➔ mark to “CACHE/INTVAL REC”.
- 5 Press the MENU knob.

The ➔ mark on the left of “CACHE/INTVAL REC” changes to a ● mark and the ● mark on the left of the setting changes to a ? mark.

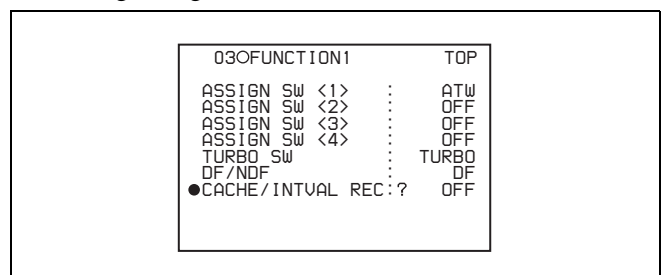

- 6** Turn the MENU knob until A. INT appears.

As you turn the MENU knob, the setting changes in the following sequence: OFF ↔ CACHE ↔ A. INT ↔ M. INT.

When A. INT appears, the camcorder is in Auto Interval Rec mode. The TALLY indicator (green) in the viewfinder flashes (one flash/second) while the camcorder is in this mode. Also, TAKE TOTAL TIME, REC TIME and PRE-LIGHTING appear.

03OFUNCTION1		TOP
ASSIGN SW <1>	:	ATW
ASSIGN SW <2>	:	OFF
ASSIGN SW <3>	:	OFF
ASSIGN SW <4>	:	OFF
TURBO SW	:	TURBO
DF/NDF	:	DF
● CACHE/INTVAL REC	:	? A. INT
TAKE TOTAL TIME	:	5MIN
REC TIME	:	5SEC
PRE-LIGHTING	:	OFF

- 7** Press the MENU knob.

The ● mark changes to a ➔ mark and the ? mark changes to a ● mark.

- 8** Turn the MENU knob to move the ➔ mark to “TAKE TOTAL TIME” (see “Time required for shooting and time required for recording on the disc” (page 49)).

? 03OFUNCTION1		TOP
ASSIGN SW <1>	:	ATW
ASSIGN SW <2>	:	OFF
ASSIGN SW <3>	:	OFF
ASSIGN SW <4>	:	OFF
TURBO SW	:	TURBO
DF/NDF	:	DF
● CACHE/INTVAL REC	:	A. INT
➔ TAKE TOTAL TIME	:	● 5MIN
REC TIME	:	5SEC
PRE-LIGHTING	:	OFF

- 9** Press the MENU knob.

The ➔ mark on the left of “TAKE TOTAL TIME” changes to a ● mark and the ● mark on the left of the setting changes to a ? mark.

- 10** Turn the MENU knob until the desired setting of “TAKE TOTAL TIME” appears.

As you turn the MENU knob, the setting of TAKE TOTAL TIME changes in the following sequence: 5MIN ↔ 10MIN ↔ 15MIN ↔ 20MIN ↔ 30MIN ↔ 40MIN ↔ 50MIN ↔ 1H ↔ 2H ↔ 3H ↔ 4H ↔ 5H ↔ 7H ↔ 10H ↔ 15H ↔ 20H ↔ 30H ↔ 40H ↔ 50H ↔ 70H ↔ 100H.

Here MIN means minutes (5MIN is 5 minutes) and H means hours (1H is one hour).

- 11** Press the MENU knob.

The ● mark changes to a ➔ mark and the ? mark changes to a ● mark.

- 12** Turn the MENU knob to move the ➔ mark to “REC TIME”.

? 03OFUNCTION1		TOP
ASSIGN SW <1>	:	ATW
ASSIGN SW <2>	:	OFF
ASSIGN SW <3>	:	OFF
ASSIGN SW <4>	:	OFF
TURBO SW	:	TURBO
DF/NDF	:	DF
● CACHE/INTVAL REC	:	A. INT
TAKE TOTAL TIME	:	20M
➔ REC TIME	:	● 5SEC
PRE-LIGHTING	:	OFF

- 13** Press the MENU knob.

The ➔ mark on the left of “REC TIME” changes to a ● mark and the ● mark on the left of the setting changes to a ? mark.

- 14** Turn the MENU knob until the desired time to be recorded on the disc appears.

As you turn the MENU knob, the setting of REC TIME changes in the following sequence: 5SEC ↔ 10SEC ↔ 15SEC ↔ 20SEC ↔ 30SEC ↔ 40SEC ↔ 50SEC ↔ 1MIN ↔ 2MIN ↔85MIN.

Here SEC means seconds (5SEC is 5 seconds) and MIN means minutes (1MIN is one minute).

You cannot set a REC TIME that is more than one thirtieth of TAKE TOTAL TIME.

For example: When TAKE TOTAL TIME is set to 1H, the maximum value of REC TIME is 2 MIN. (60 minutes divided by 30 gives 2 minutes.)

- 15** Press the MENU knob.

The ● mark changes to a ➔ mark and the ? mark changes to a ● mark.

- 16** Turn the MENU knob to move the ➔ mark to “PRE-LIGHTING”.

? 03OFUNCTION1		TOP
ASSIGN SW <1>	:	ATW
ASSIGN SW <2>	:	OFF
ASSIGN SW <3>	:	OFF
ASSIGN SW <4>	:	OFF
TURBO SW	:	TURBO
DF/NDF	:	DF
● CACHE/INTVAL REC	:	A. INT
TAKE TOTAL TIME	:	20M
REC TIME	:	5SEC
➔ PRE-LIGHTING	:	● OFF

- 17** Press the MENU knob.

The **▶** mark on the left of “PRE-LIGHTING” changes to a **●** mark and the **●** mark on the left of the setting changes to a **?** mark.

- 18** Turn the MENU knob until the desired time to turn on the light before starting to record appears.

As you turn the MENU knob, the PRE-LIGHTING time changes in the following sequence: OFF ↔ 2SEC ↔ 5SEC ↔ 10SEC.

Notes

- Set the LIGHT switch on the camcorder to AUTO to turn on the light before recording. The light switch must also be set to ON. With these settings, the light turns on and off automatically. (However, the light remains on continuously if the off time is less than 5 seconds.)
- When the LIGHT switch is set to MANUAL and the light switch is set to ON, the light remains on continuously.

- 19** Press the MENU knob.

The **●** mark changes to a **▶** mark and the **?** mark changes to a **●** mark.

- 20** To end the menu operation, set the MENU ON/OFF switch to OFF.

The menu disappears from the screen and the message “AUTO INTERVAL **M**S” indicating Auto Interval Rec mode appears along the bottom of the screen.

“**M**S” indicates the shooting interval. For example, the message “AUTO INTERVAL 00M04S” indicates that the shooting interval is four seconds.

Note

The camcorder exits Auto Interval Rec mode whenever it is powered off. However, the TAKE TOTAL TIME and REC TIME settings are maintained. You do not need to set them again the next time you use Auto Interval Rec mode.

To shoot and record in Auto Interval Rec mode

Proceed as follows.

- 1** After performing the basic procedures for shooting and recording, following the instructions in 3-2-1 “Basic Procedures” (page 41), secure the camcorder so that it will not move.
- 2** Press the REC START button on the camcorder or the VTR button on the lens.

The camcorder starts recording in Auto Interval Rec mode. When you use the PRE-LIGHTING function, recording starts after the light is switched on.

The actual recording to disc begins when the camcorder has saved about ten seconds of video in memory, so disc access is intermittent.

While recording in Auto Interval Rec mode, the TALLY indicator (green) in the viewfinder flashes (4 flashes/second) and the message “AUTO INTERVAL **M**S” flashes on the viewfinder screen.

When the camcorder is capturing the picture in memory, the REC indicator (red) in the viewfinder lights.

After the length of time for recording on the disc (REC TIME) has elapsed, the camcorder automatically stops recording.

To continue auto interval recording

Press the REC START button on the camcorder or the VTR button on the lens again.

The camcorder starts recording in Auto Interval Rec mode again.

To interrupt auto interval recording

Press the REC START button or the VTR button on the lens. The camcorder stops recording.

However, disc access may occur for recording picture data already stored in memory.

To end auto interval recording

You can exit Auto Interval Rec mode using the following two methods:

- Set the POWER switch to OFF.
- Set CACHE/INTVAL REC to OFF on the FUNCTION 1 page.

Time required for shooting and time required for recording on the disc

Auto Interval Rec mode is effective for shooting objects that move very slowly. To use this function, you need to set the total time for shooting (TAKE TOTAL TIME) and the length of time for recording on the disc (REC TIME). The time required for shooting is the time required to capture the very slowly moving subject, and the camcorder must be arranged so that during this time the subject is always in the frame.

The disc recording time indicates the running time of the completed recording. The camcorder calculates the time-lapse interval from these two times.

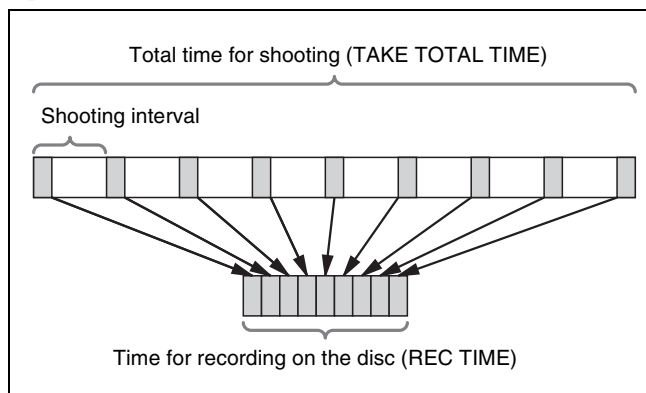

Notes on Auto Interval Rec mode

Note the following points.

i.LINK

During interval recording, signal input/output through the i.LINK interface is impossible.

Time code

In Auto Interval Rec mode, the internal time code generator runs in R-RUN mode regardless of how the F-RUN/SET/R-RUN switch is set.

Audio

Audio signals are not recorded in Auto Interval Rec mode.

Playback control buttons

While recording in Auto Interval Rec mode, you cannot use the playback control buttons (EJECT, F REV, F FWD, NEXT, PREV, PLAY/PAUSE and STOP). To use these buttons, stop recording by pressing the REC START button or the VTR button on the lens.

Menu operation

While recording in Auto Interval Rec mode, you cannot change the settings of CACHE/INTVAL REC, TAKE TOTAL TIME and REC TIME. To change the settings, stop recording by pressing the REC START button or the VTR button on the lens.

When the camcorder power is switched off during recording in Auto Interval Rec mode

- When you set the POWER switch to OFF, the camcorder will switch off by itself after disc access has continued for a few seconds to record the picture data stored in memory.
- If you remove the battery, unplug the DC cable, or cut power to the AC adaptor during auto interval recording, picture data stored before recording stops (a maximum of ten seconds) may be lost. Take care when changing the battery.

Manual Interval Rec mode settings and shooting

Manual Interval Rec has the following two modes.

Single shot mode: Each time the REC START button or VTR button on the lens is pressed, the camcorder captures to memory a single shot consisting of the specified number of video frames.

Consecutive mode: Once the REC START button or VTR button on the lens is pressed, the camcorder captures consecutive shots to memory at the specified interval, with each shot consisting of the specified number of video frames.

To make settings before shooting

Proceed as follows.

- 1 Carry out steps 1 to 5 of the procedure “To make settings before shooting” (page 47), to select CACHE/INTVAL REC on the FUNCTION 1 page.
- 2 Turn the MENU knob until “M. INT” appears.

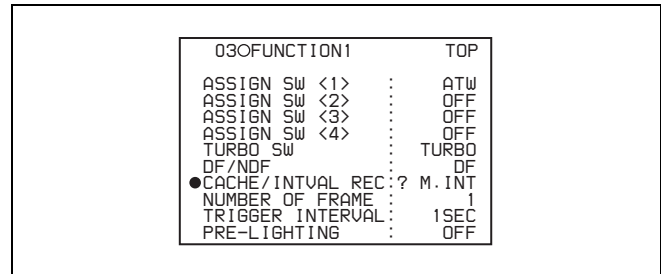

As you turn the MENU knob, the setting changes in the following sequence: OFF ↔ CACHE ↔ A. INT ↔ M. INT.

When M. INT appears, the camcorder is in Manual Interval Rec mode and the TALLY indicator (green) in the viewfinder flashes. “NUMBER OF FRAME” and “TRIGGER INTERVAL” appear. When TRIGGER INTERVAL is set to other than “M”, “PRE-LIGHTING” also appears.

- 3 Press the MENU knob.

The ● mark on the left of “CACHE/INTVAL REC” changes to a ➔ mark and the ? mark on the left of the setting changes to a ● mark.

- 4 Turn the MENU knob to move the ➔ mark to “NUMBER OF FRAME”.

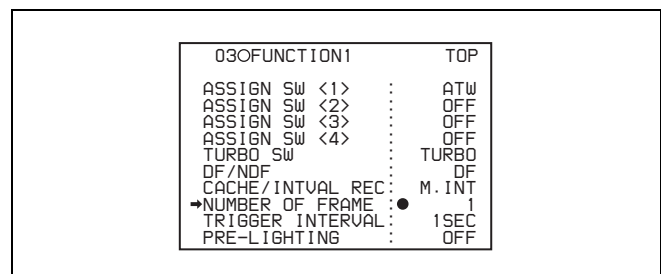

- 5 Press the MENU knob.

The ➔ mark on the left of “NUMBER OF FRAME” changes to a ● mark and the ● mark on the left of the setting changes to a ? mark.

- 6 Turn the MENU knob until the desired number of frames to be recorded in each shot appears.

As you turn the MENU knob, the number changes in the following sequence: 1 ↔ 2 ↔ 4 ↔ 8.

- 7 Press the MENU knob.

The ● mark changes to a ➔ mark and the ? mark changes to a ● mark.

- 8** Turn the MENU knob to move the ➔ mark to “TRIGGER INTERVAL”.

- 9** Press the MENU knob.

The ➔ mark on the left of “TRIGGER INTERVAL” changes to a ● mark and the ● mark on the left of the setting changes to a ? mark.

- 10** Turn the Menu knob to select the desired Manual Interval Rec mode.

- To select the single shot mode (recording only one shot after one operation), set “TRIGGER INTERVAL” to “M”. In the viewfinder, the TALLY indicator (green) flashes twice per second.
- To select the consecutive mode (recording shots repeatedly after one operation), set “TRIGGER INTERVAL” to the desired length of interval. In the viewfinder, the TALLY indicator (green) flashes once per second.

03OFUNCTION1	TOP
ASSIGN SW <1>	ATW
ASSIGN SW <2>	OFF
ASSIGN SW <3>	OFF
ASSIGN SW <4>	OFF
TURBO SW	TURBO
DF/NDP	DF
CACHE/INTVAL REC	M. INT
NUMBER OF FRAME	2
● TRIGGER INTERVAL: ?	2SEC
PRE-LIGHTING	OFF

As you turn the MENU knob, the setting changes in the following sequence: M ↔ 1SEC ↔ 2SEC.....12H ↔ 24H.

- 11** Press the MENU knob.

The ● mark changes to a ➔ mark and the ? mark changes to a ● mark.

- 12** If you selected the consecutive mode in step 10 (anything other than “M”), turn the MENU knob to move the ➔ mark to “PRE-LIGHTING”.

03OFUNCTION1	TOP
ASSIGN SW <1>	ATW
ASSIGN SW <2>	OFF
ASSIGN SW <3>	OFF
ASSIGN SW <4>	OFF
TURBO SW	TURBO
DF/NDP	DF
CACHE/INTVAL REC	S. INT
NUMBER OF FRAME	2
TRIGGER INTERVAL	1SEC
➔PRE-LIGHTING ●	OFF

- 13** Press the MENU knob.

The ➔ mark to the left of “PRE-LIGHTING” changes to a ● mark, and the ● mark to the left of the setting changes to a ? mark.

- 14** Turn the MENU knob to display the length of time to light before recording.

The setting changes in the following sequence: OFF ↔ 2SEC ↔ 5SEC ↔ 10SEC.

Notes

- Set the LIGHT switch on the camcorder to AUTO to turn on the light before recording. The light switch must also be set to ON. With these settings, the light turns on and off automatically. However, the light remains on continuously if the off time is less than 5 seconds.
- When the LIGHT switch is set to MANUAL and the light switch is set to ON, the light remains on continuously.

- 15** Press the MENU knob.

The ● mark changes to a ➔ mark and the ? mark changes to a ● mark.

- 16** To end the menu operation, set the MENU ON/OFF switch to OFF.

The menu disappears from the viewfinder screen and the following message appears along the bottom of the screen, indicating the current Manual Interval Rec mode.

In single shot mode: MANU INTERVAL *FRAME

In consecutive mode: MANU INTERVAL *SEC *FRAME

“*FRAME” means the number of frames and “*SEC”, the length of interval for the consecutive mode.

Note

The camcorder exits Manual Interval Rec mode whenever it is powered off. However, the NUMBER OF FRAME, TRIGGER INTERVAL and PRE-LIGHTING settings are maintained. You do not need to set them again the next time you use Manual Interval Rec mode.

To shoot and record in Manual Interval Rec mode
After making the required settings, proceed as follows.

- 1 After performing the basic procedure for shooting and recording following the instructions in 3-2-1 “Basic Procedures” (page 41), secure the camcorder so that it will not move.
- 2 Press the REC START button on the camcorder or the VTR button on the lens.

The camcorder starts recording in Manual Interval Rec mode. In the viewfinder, “MANU INTERVAL *FRAME” and the TALLY indicator (green) flash.

- In the single shot mode, the TALLY indicator flashes twice per second.
- In the consecutive mode, the TALLY indicator flashes four times per second.

To exit Manual Interval Rec mode

Do one of the following.

- In the single shot mode, press the EJECT button.
- In the consecutive mode, press the camcorder REC START button or the lens VTR button to stop recording.
- Set the camcorder POWER switch to OFF.

After the camcorder has exited from Manual Interval Rec mode, it records picture data stored in memory to the disc.

Notes on Manual Interval Rec mode

Take note of the following points.

i.LINK

During interval recording, signal input/output through the i.LINK interface is impossible.

Time code

In Manual Interval Rec mode, the internal time code generator runs in R-RUN mode regardless of how the F-RUN/SET/R-RUN switch is set.

Audio

Audio signals are not recorded in Manual Interval Rec mode.

Playback control buttons

While recording in the single shot mode of Manual Interval Rec mode (the TALLY indicator (green) in the viewfinder flashes twice per second), you cannot use most of playback control buttons (F REV, F FWD, NEXT, PREV, PLAY/PAUSE, and STOP). To exit the single shot mode, press the EJECT button.

While recording in the consecutive mode of Manual Interval Rec mode (the TALLY indicator (green) flashes four times per second), you cannot use the disc control buttons (EJECT, F REV, F FWD, NEXT, PREV, PLAY/PAUSE and STOP). To use these buttons, stop recording by pressing the REC START button or the VTR button on the lens.

Menu operation

In the single shot mode of Manual Interval Rec mode, you cannot change the settings of “CACHE/INTVAL REC” and “NUMBER OF FRAME” on the FUNCTION 1 page after the camcorder starts recording. To change the settings, stop recording by pressing the EJECT button or setting the POWER switch to OFF.

While recording in the consecutive mode of Manual Interval Rec mode, you cannot change the settings of CACHE/INTVAL REC, NUMBER OF FRAME and

TRIGGER INTERVAL on the FUNCTION 1 page. To change these settings, stop recording by pressing the REC START button or the VTR button on the lens.

When the camcorder power is switched off during recording in Manual Interval Rec mode

- When you set the POWER switch to OFF, the camcorder will switch off by itself after disc access has continued for a few seconds to record the picture data stored in memory.
- If you remove the battery, unplug the DC cable, or cut the power to the AC adaptor during manual interval recording, picture data stored before recording stops (a maximum of ten seconds) may be lost. Take care when changing the battery.

3-2-6 Retaking the Most Recent Clip

A retake function is available, making it easy to erase and retake the most recently recorded clip.

To use the retake function, you need use the FUNCTION 1 menu to assign it to one of the assignable switches (ASSIGN 1, ASSIGN 3, ASSIGN 4, or TURBO GAIN).

For details about operation, see section 7-3-5 “Assigning Functions to ASSIGN 1/2/3/4 Switches” (page 120).

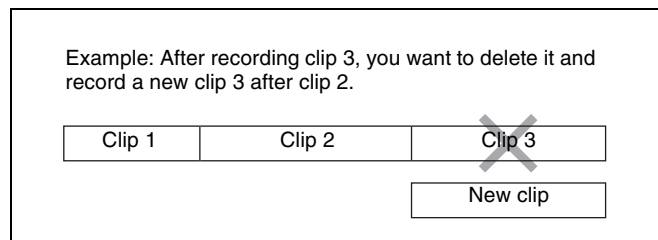

To retake the most recent clip

With recording paused or after the end of a preview (*see page 55*), proceed as follows.

- 1 Press the switch or button to which the retake function has been assigned.

While the button is pressed, the last frame of the recorded clip and the message “PUSH RET FOR CLIP DELETE” appears.

- 2 In this state, press the RET button.

The message “DELETING LAST CLIP” appears, and the processing for deleting the last recorded clip begins.

When the deleting has finished, the message “LAST CLIP WAS DELETED” appears.

Note

If an operation (other than recording review) which is not a retake operation is carried out after the last clip has been

recorded, the retake function does not work even when the camcorder is in the recording pause state. In this case, the message “RE-TAKE NOT ALLOWED!” appears. When you want to replace the last clip with a new clip, see 3-2-2 “Deleting Clips” (page 43). Once you carry out a retake operation, the last clip is deleted even if you do not carry out a recording operation afterwards.

3-2-7 Auto Clip List Recoding for Automatic Inclusion of Recorded Clips in Clip Lists

Auto clip list recoding is a function for automatically including the clips generated by recording operations in a selected clip list. The updated clip list is saved to the disc. Proceed as follows.

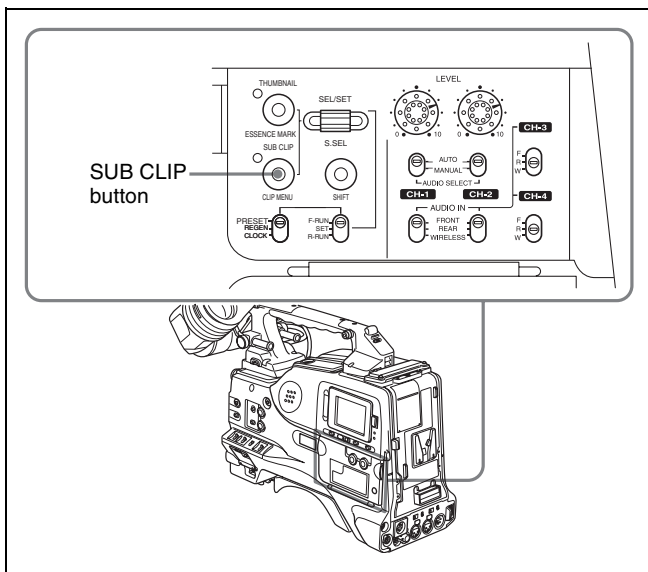

- 1 Insert a disc.
- 2 Load a clip list from the disc.
 - To create a new clip list, load a NEW FILE (empty) clip list.
 - To add clips to an existing clip list, load that clip list.

Note

Always load either a new or existing clip list from disc.

For operations, see 4-3-3 “Loading a Clip List From Disc Into the Current Clip List” (page 67).

- 3 Press the SUB CLIP button, turning on the sub clip indicator.

The camcorder enters auto clip list recording mode. The viewfinder screen shows the number of the clip list loaded in the current clip list.

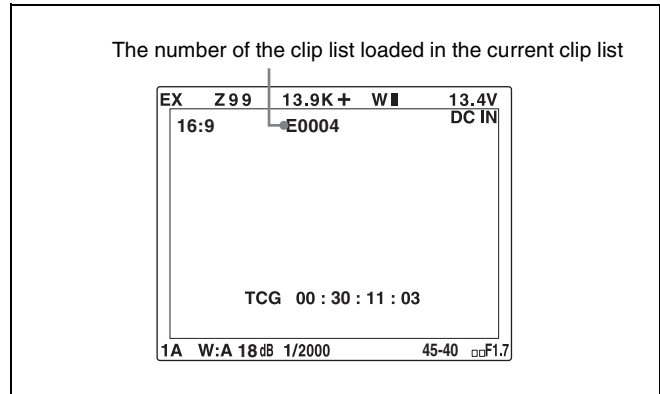

- 4 Press the REC START button or the VTR button on the lens to start recording, and press again to stop recording.

A clip is generated automatically from the video and audio recorded in this interval, and added as a sub clip to the the currently loaded clip list. The updated list is also written to disc automatically.

- 5 Repeat the process of recording and stopping until you have included all the required clips.

To change target clip lists, carry out step 2 once more to load the desired clip list into the current clip list.

To exit auto clip list coding mode

Press the SUB CLIP button, turning off the sub clip indicator.

3-3 Checking Recording and Playback

Disc playback start position

Although this unit uses optical discs, it is designed to offer the most convenient features of tape playback by VTRs. One of these is the playback start position, which works in the same way as tape, as described below.

After playback stop

The unit stops at the position where the STOP button was pressed.

Press the PLAY/PAUSE button to resume playback at the stop position.

After recording

The unit stops at the position where recording ended. To play back a clip, press the PREV button to move to the start frame of any clip, or press the PREV button with the PLAY/PAUSE button held down to move to any position.

After disc insertion

The unit stops at the position of the disc when it was most recently ejected.

Press the PLAY/PAUSE button to resume playback at the most recent position.

The playback position is saved to the disc when the disc is ejected, which allows playback to start at that position whenever it is loaded into any XDCAM player.

Note

The playback position is not recorded to the disc if the disc is set to REC INH.

3-3-1 Normal Playback

By pressing the PLAY/PAUSE button, you can review any length of recording on the viewfinder screen in black and white or in color on the color LCD. There are two other ways to review the recording.

- **Recording review:** You can view the last two seconds of the recording on the viewfinder screen in black and white or in color on the color LCD.
- **Color playback:** You can see the recording in color on a color video monitor without the need for any external adaptor.

You may also view the picture during a fast forward or reverse search.

See 2-3 “Audio Functions” on page 16 for details about the switches and controls used to select the audio output signal and to adjust the audio level.

Deteriorating playback conditions

Deteriorating playback may be due to the following causes.

- **Scratches and dust on the disc surface**
This includes fingerprints, dust from the air, tar from cigarette smoke, and so on.
Scratches and soiling which occur before recording are not a problem because they are registered in advance as defects, and recording avoids them. However, scratches and soiling which occur after recording can lead to deteriorating playback conditions.
- **Aging of disc recording layers**
Over several decades, the recording layers of optical discs can age and cause deteriorating playback conditions.
You can use this function to check archival discs and other discs which have been stored for extended periods, so that you can take action before the deterioration progresses further.
- **Deteriorating laser diodes performance**
The performance of the laser diodes used in optical heads can worsen with age, leading to deteriorating playback conditions.
You can use the digital clock to check the total optical output time of optical heads.

Refer to the Maintenance Manual for an approximate guide to when it is time to replace optical heads.

To prevent playback conditions from deteriorating

Pay attention to the following points when handling discs.

- Do not open disc cartridges and touch discs directly with your hands.
- Do not store for long periods in locations which are dusty or exposed to air circulated by fans.
- Do not store for long periods under high temperatures or in locations exposed to direct sunlight.

If playback conditions have deteriorated

Read errors occur when playback conditions continue to deteriorate.

When a read error occurs, the message “DISC DEFECT” appears, the video freezes, and audio is muted.

If this happens, check the following points.

Whether the disc displays the same playback condition on other XDCAM devices:

If so, the surface of the disc may be dirty or scratched, or the performance of the recording layers on the disc may have worsened due to age. Do not use discs with these symptoms.

Whether every disc inserted into an XDCAM device displays the same playback conditions:

If so, the performance of the laser diodes may have deteriorated. Check the total optical output time.

3-3-2 Checking the Last Two Seconds of the Recording — Recording Review

If you press the RET button on the lens while recording is paused, the last two seconds of the recording is played back on the viewfinder screen and the color LCD. Use this function to check whether recording went smoothly. If you hold down the RET button, a low-speed reverse search begins at a position two seconds before the recording end position. When you release the RET button, the reverse search stops and playback in the forward direction begins. After playback, the camcorder is ready to start recording again.

By assigning the the same function as that of the RET button on the lens to the ASSIGN 1/3/4 switch, you can use the switch in the same way as the lens RET button.

For details, see 7-3-5 “Assigning Functions to ASSIGN 1/2/3/4 Switches” on page 120.

3-3-3 Checking the Recording on the Color Video Monitor — Playback in Color

Connect a color video monitor to the VIDEO OUT connector of the camcorder. By pressing the PLAY/PAUSE button, you can view the recorded picture. When the CBK-SD01 SDI Output Board is installed, you can connect a color video monitor provided with an SDI input connector.

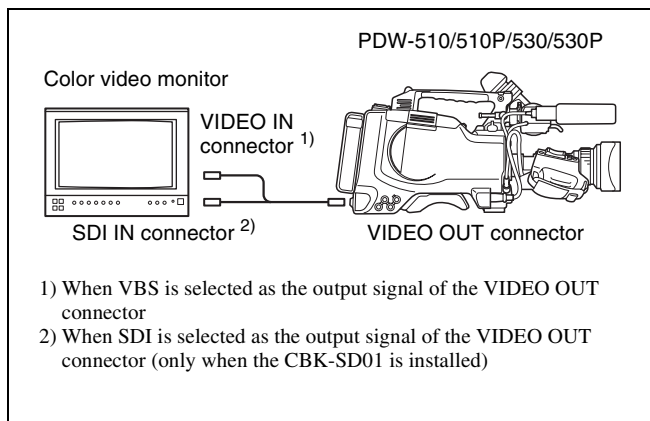

Color playback

Note

You can select either VBS or SDI as the output signal of the VIDEO OUT connector when the CBK-SD01 is installed.

For details, see 7-3-2 “Selecting the Output Signals” on page 117.

3-3-4 Thumbnail Search

Cuing up a desired clip

To display the thumbnail images of all clips on the disc, and cue up a desired clip, proceed as follows.

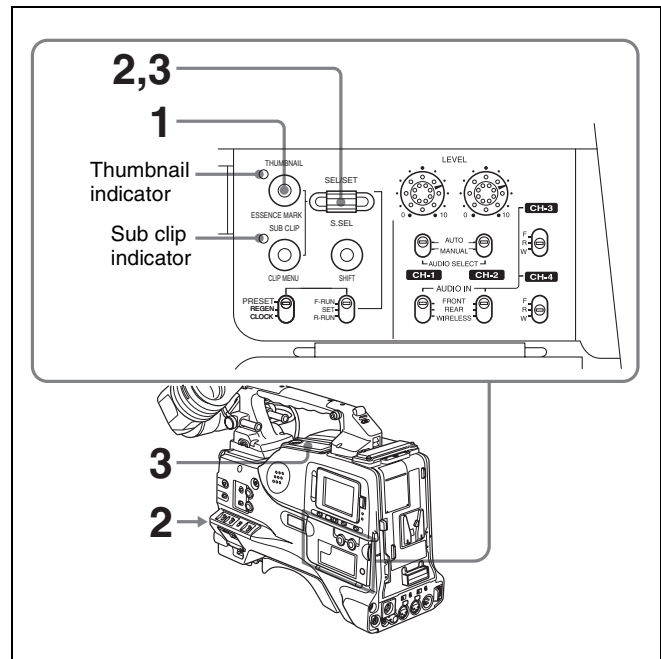

- 1 With the sub clip indicator off, press the THUMBAIL button, turning on the thumbnail indicator.

The thumbnails of all clips on the disc appear.

Notes

- If the MENU ON/OFF switch is set to ON, set it to OFF and press the THUMBAIL button.
- If you set the MENU ON/OFF to ON during thumbnail display, thumbnail display is cancelled and replaced with menu display.

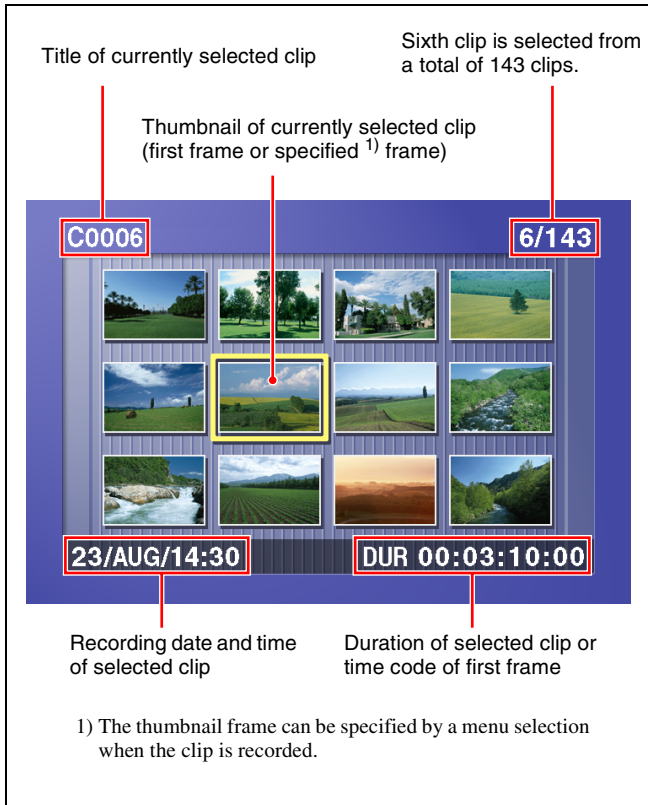

To switch between duration and timecode display in the thumbnail display

Press the HOLD button. Each press of the HOLD button switches the display between duration and time code.

To escape from the thumbnail display to the full-screen display

Press the THUMBNAIL button, turning off the indicator.

- Turn the SEL/SET dial or the MENU knob to select the desired clip.

You can also select clips with the following operations.

Press the PREV or NEXT button: Select the previous or next clip.

Press the PREV or NEXT button with the F REV or F FWD button held down: Select the first or last clip.

- To cue up the selected clip, press the SEL/SET dial or the MENU knob.

To start playback from the selected clip, press the PLAY/PAUSE button.

Cuing up a frame including an essence mark

Proceed as follows.

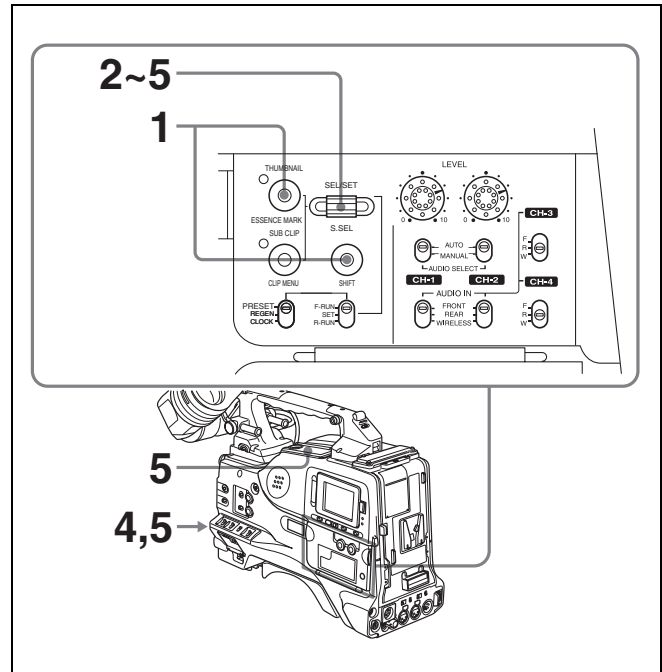

- Hold down the SHIFT button, and press the THUMBNAIL button.

The essence mark selection screen appears.

Notes

- If the MENU ON/OFF switch is set to ON, set it to OFF and press the THUMBNAIL button.
- If you set the MENU ON/OFF to ON during thumbnail display, thumbnail display is cancelled and replaced with menu display.



To escape from the essence mark selection screen to the previous screen

Press the RESET button.

- Turn the SEL/SET dial or the MENU knob to select the desired essence mark.

- Press the SEL/SET dial or the MENU knob.

Thumbnails of the frames including the selected essence mark appear.

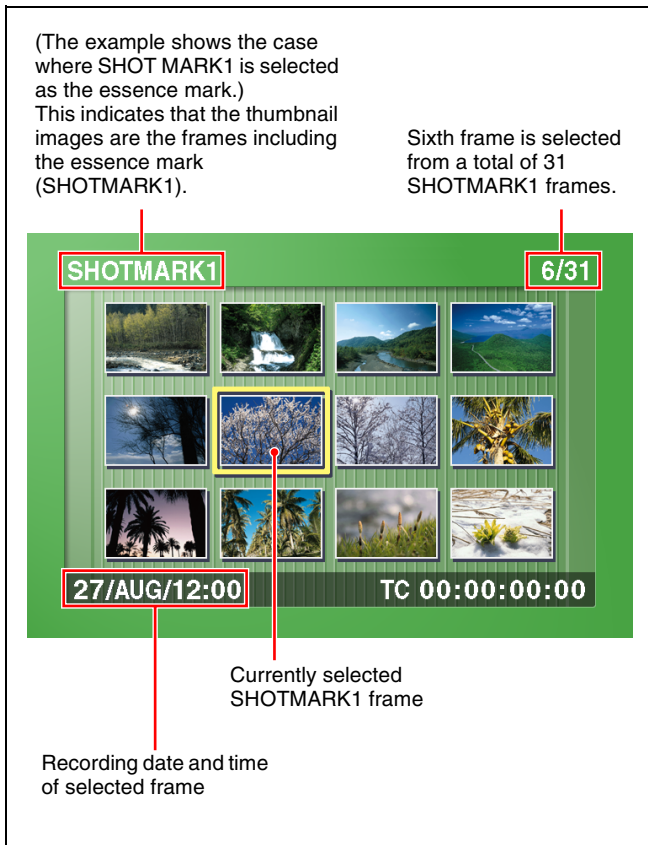

- 4** Turn the SEL/SET dial or the MENU knob to select the desired frame.

You can also select frames with the following operations.

Press the PREV or NEXT button: Select the previous or next frame.

Press the PREV or NEXT button with the F REV or F FWD button held down: Select the first or last frame.

- 5** Press the SEL/SET dial or the MENU knob to cue up the selected clip.

To start playback from the selected frame, press the PLAY/PAUSE button.

3-3-5 Clip List Playback

You can play back clips in the order of clip lists created with the scene selection function (see page 61).

Playing back in clip list order

Proceed as follows.

- 1** If the clip list that you want to play exists on the disc, load it into the current clip list (see page 61).

For the clip list loading operation, see 4-3-3 “Loading a Clip List From Disc Into the Current Clip List” (page 67).

- 2** Press the SUB CLIP button, turning it on.

- 3** Press the PLAY/PAUSE button.

Playback begins from the first sub clip in the current clip list.

Note

Depending on the length of sub clips in the clip list and their arrangement on the disc, playback may freeze momentarily between sub clips.

Cuing up with sub clip thumbnails

With the desired clip list loaded in the current clip list, proceed as follows.

- 1** Press the SUB CLIP button and the THUMBNAIL button, turning on the indicators.

Thumbnails of the first frames in the sub clips appear.

Notes

- If the MENU ON/OFF switch is set to ON, set it to OFF and press the THUMBNAIL button.
- If you set the MENU ON/OFF to ON during thumbnail display, thumbnail display is cancelled and replaced with menu display.

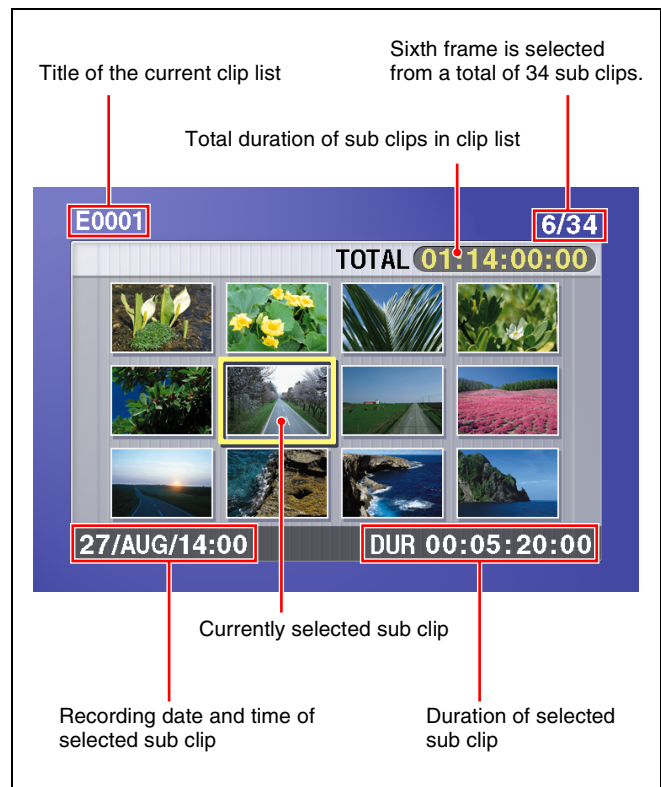

To escape from the thumbnail display to the full-screen display

Press the THUMBNAIL button, turning it off.

- 2** Turn the SEL/SET dial or the MENU knob to select the sub clip you want to cue up.
- 3** To cue up the selected sub clip, press the SEL/SET dial or the MENU knob.

To start playback from the selected sub clip, press the PLAY/PAUSE button.

3-4 Recording Video Signals from External Equipment

With this camcorder, you can select in the OPERATION menu whether to record the video captured by the camera, or whether to record a signal from an external video device.

If this switching function is assigned to the ASSIGN 2 switch, regardless of the setting in the OPERATION menu, you can make the selection with the ASSIGN 2 switch. While recording video from an external device, the indication “EXT” appears on the viewfinder screen.

Notes

- You can switch the signals to be recorded using the ASSIGN 2 switch or by a menu operation at any time while recording on the disc. However, the signals recorded at the point where the signal is switched may be distorted. If the camera/external switching function is assigned to the ASSIGN 2 switch, you cannot use the following menu operations to switch between camera and external source input.
- Even when the REC VIDEO SOURCE item is set to “EXT”, if the external video signal is not input to the i.LINK DV IN/OUT S400 connector or the GENLOCK IN connector, the camcorder does not switch to EXT mode, and the pictures being shot by the camcorder are recorded on the disc.

3-4-1 Recording a DV Stream From External Equipment

Note

Recording a DV stream is possible only when the video recording format is DVCAM.

If the currently set video recording format is other than DVCAM, change it to DVCAM referring to 5-1-1 “Setting the Video Recording Format” on page 70.

Proceed as follows.

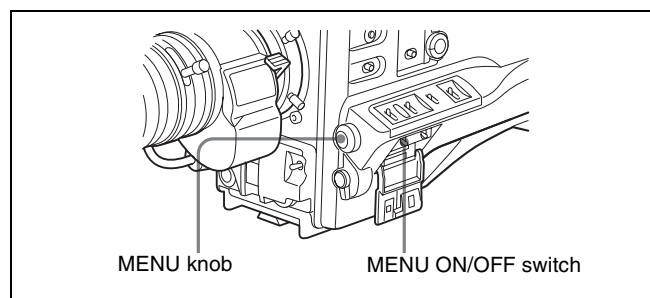

- 1 Holding down the MENU knob, set the MENU ON/OFF switch to ON.

The TOP menu appears.

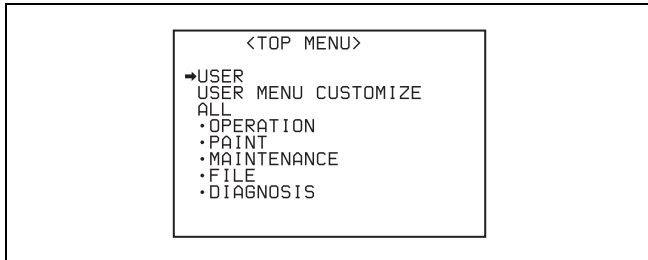

- 2 Turn the MENU knob to move the ➔ mark to "OPERATION".

- 3 Press the MENU knob.

If this is the first time the OPERATION menu has been displayed, the CONTENTS page of the OPERATION menu appears. If the menu has been used before, the last accessed page appears.

- 4 If the CONTENTS page is displayed, turn the MENU knob to move the ➔ mark to "SOURCE SEL", and press the MENU knob.

If a different page is displayed, turn the MENU knob until the SOURCE SEL page appears, then press the MENU knob to select the page.

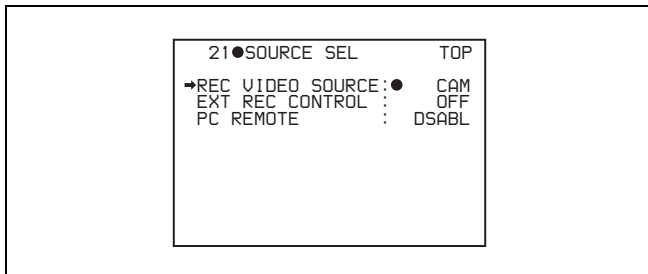

- 5 Turn the MENU knob to move the ➔ mark to "REC VIDEO SOURCE", then press the MENU knob.

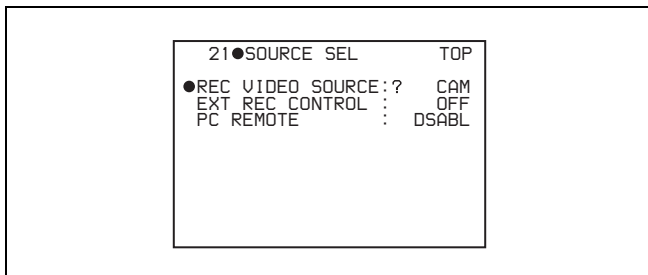

Item	Description
CAM	Records the pictures being shot by the camcorder.

Item	Description
EXT	Records video signals from the external equipment connected to the i.LINK DV IN/OUT or GENLOCK IN connector.

The ➔ mark on the left of "REC VIDEO SOURCE" changes to a ● mark and the ● mark on the left of the setting changes to a ? mark.

- 6 Turn the MENU knob to display "EXT".

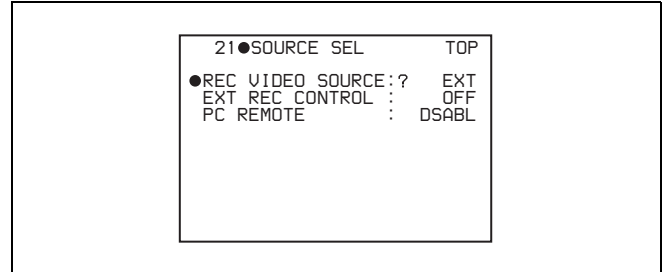

- 7 Press the MENU knob.

The ● mark changes to a ➔ mark and the ? mark changes to a ● mark.

Notes

- During i.LINK DV stream input, the image on the viewfinder screen and the color LCD may occasionally show an overlapped frame or skipped frame, but this does not affect the recording on the disc.
- During i.LINK DV stream input, the audio within the DV stream is recorded as the audio input.
- During i.LINK DV stream input, a black picture is shown on the viewfinder screen and on the color LCD, and nothing is recorded, if the DV device on the sending side of the i.LINK DV connection is also in a stream input state.

3-4-2 Recording Analog Composite Signals (with the CBK-SC01 Installed)

Installing the CBK-SC01 Composite Input Board in the camcorder enables you to record analog composite signals from external equipment connected to the GENLOCK IN connector.

Proceed as follows.

- 1 Display the SOURCE SEL page on the screen.

For the operation, see 3-4-1 "Recording a DV Stream From External Equipment" on page 58.

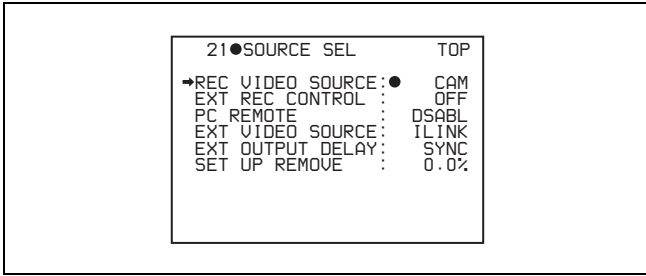

- 2 Move the **▶** mark to “EXT VIDEO SOURCE”, and press the MENU knob.
- 3 Turn the MENU knob to display “CMPST”.

This ends the setting.

When you input analog composite signals to the GENLOCK IN connector of the camcorder, these signals are displayed on the viewfinder screen and the color LCD, and can be recorded on the disc.

Note

Even when the GENLOCK ON/OFF item is set to “OFF” on the GENLOCK page of the MAINTENANCE menu, the camcorder is automatically synchronized with the external reference video signal when the external video signal is input to the GENLOCK IN connector in EXT mode. When the setting is switched to CAM mode, or when no signals are input to the GENLOCK IN connector even in EXT mode, the camcorder is reset to the original setting.

3-5 Freezing a Picture During Playback

Viewing frozen pictures

Proceed as follows.

- 1 Press the PLAY/PAUSE button to start playback.
- 2 Press the PLAY/PAUSE button again at the instant when you want to freeze the picture.

A frozen picture appears.

The time code is displayed in the counter display and the PLAY/PAUSE indicator flashes (one flash/second).

- 3 To restart playback, press the PLAY/PAUSE button once again.

When remotely controlling the camcorder from an RM-B150/B750 remote control unit

You can perform the same operation from the RM-B150/B750.

4-1 Overview

Clip lists and sub clips

Scene selection is a function which allows you to save, load, and edit clip lists consisting of clips recorded on disc, or parts of clips, arranged in any order. Clips or parts of clips which have been inserted into clip lists are called sub clips.

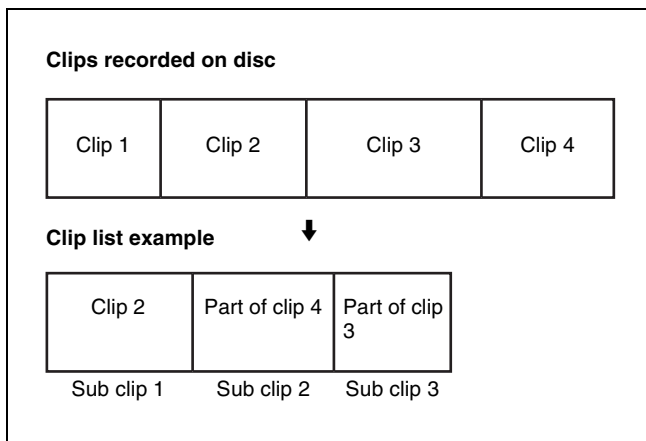

Clip lists on disc and the current clip list

Up to 99 clip lists can be saved on disc. These clip lists can be loaded, one at a time, into the camcorder's memory for playback and editing. Newly created clip lists are also saved in the camcorder's memory.

This manual refers to the clip list which is currently loaded into the camcorder's memory as the "current clip list".

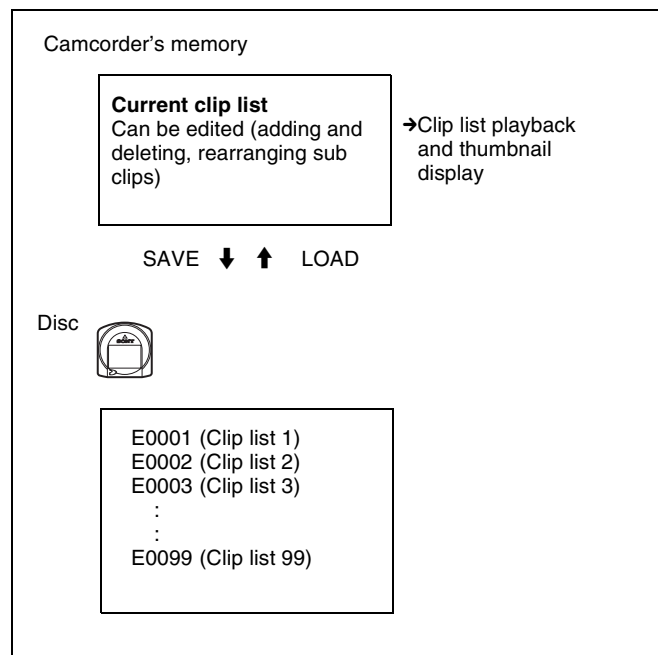

The current clip list is always the target of sub clip creation and editing.

Notes

- Data in the camcorder's memory is lost when the camcorder is powered off or the disc is ejected. After creating or editing a clip list, be sure to save it to disc.
- The current clip list cannot be saved to disc when the disc's write-protect tab is set to the recording disabled position.

4-2 Basic Operations

4-2-1 Creating Clip Lists

You can create a clip list by selecting a desired clip from the thumbnail display, and including it in the clip list as a sub clip.

Note

Up to 99 clip lists can be handled in the CLIP menu.

Including a clip selected from the thumbnail display in the clip list

Proceed as follows.

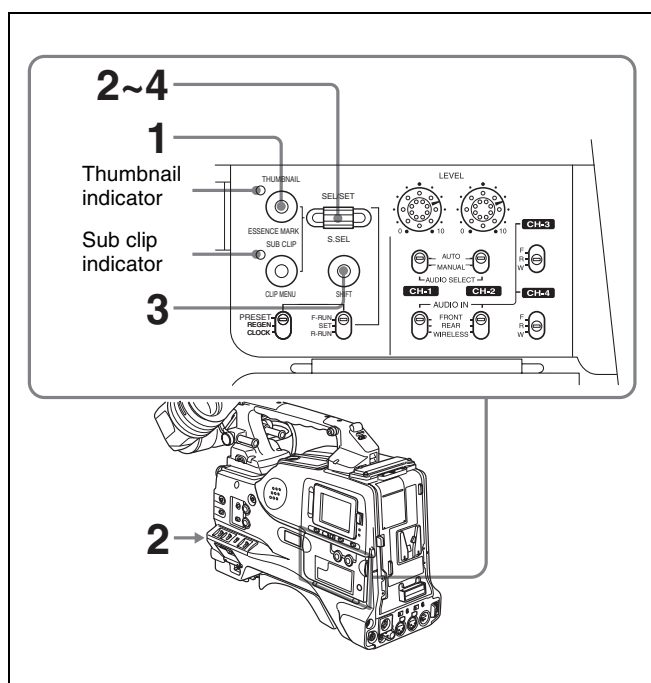

- 1 With the sub clip indicator off, press the THUMBNAIL button, turning on the thumbnail indicator.

The thumbnails of the clips on the disc appear.

Notes

- If the MENU ON/OFF switch is set to ON, set it to OFF and press the THUMBNAIL button.
- If you set the MENU ON/OFF to ON during thumbnail display, thumbnail display is cancelled and replaced with menu display.



- 2 Use the SEL/SET dial or the MENU knob to select the clip you want to include in the clip list.
- 3 Hold down the SHIFT button, and press the SEL/SET dial.

The scene selection window appears.

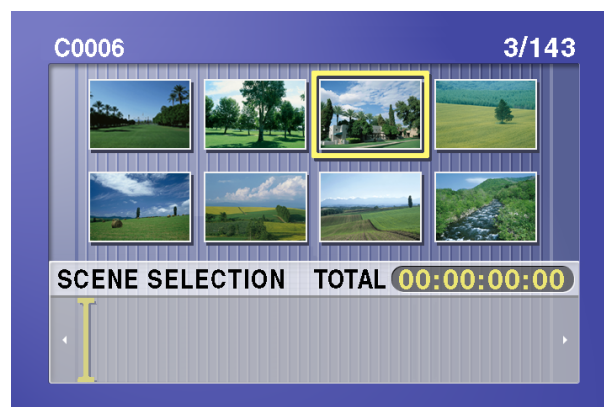

To escape from the scene selection window to the previous screen

Press the RESET button.

- 4 Press the SEL/SET dial or the MENU knob.
This adds the selected clip to the clip list as a sub clip. At the same time, this closes the scene selection window and returns to the original thumbnail display.
- 5 Repeat steps 2 to 4 until all desired clips have been added to the clip list.

The scene selection window shows the thumbnails of the sub clips that have already been included in the clip list. The cursor within the window indicates the position in which the next sub clip will be included.

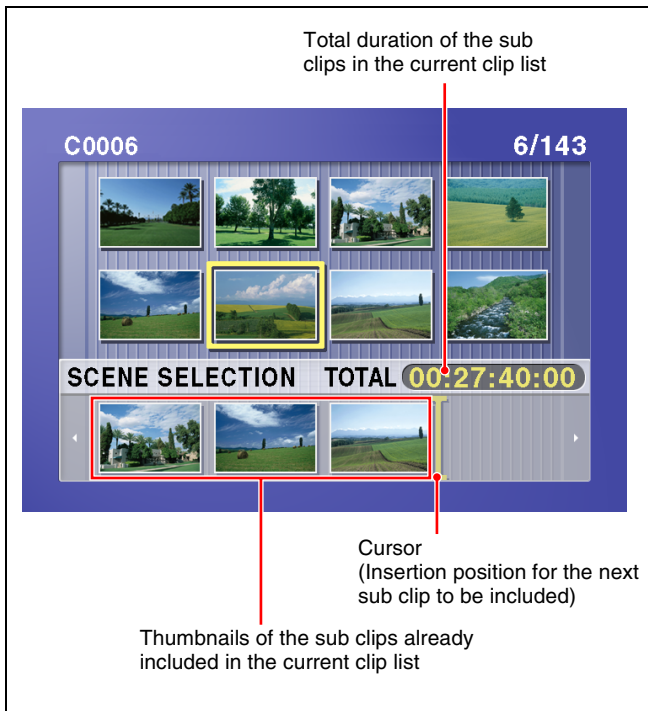

To move the cursor within the scene selection window

When the scene selection window appears as you carry out step 3, use the SEL/SET dial to move in the desired direction.

- 6 When you have added all of the desired clips, save the current clip list to disc.

For details, see 4-3-2 “Saving the Current Clip List to Disc” (page 66).

Note

Unless the current clip list has been saved to disc, its contents will be lost when the camcorder is powered off or the disc is ejected. After creating a clip list, be sure to save it.

4-2-2 Editing Clip Lists

You can carry out the following operations on sub clips within a clip list.

- Moving sub clips (changing the sequence)
- Trimming sub clips
- Deleting sub clips

For details of how to add sub clips, see the procedure in 4-2-1 “Creating Clip Lists” (page 62).

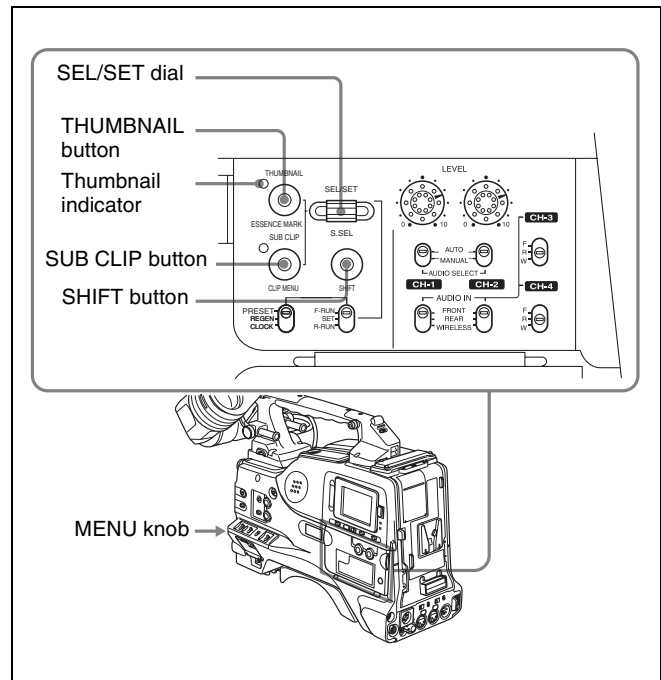

Loading a clip list to edit from disc

Proceed as follows.

- 1 With the thumbnail indicator off, hold down the SHIFT button, and press the SUB CLIP button.

The CLIP menu appears.

Notes

- If the MENU ON/OFF switch is set to ON, set it to OFF, then press the SUB CLIP button with the SHIFT button held down.
- If you set the MENU ON/OFF switch to ON while the CLIP menu is being displayed, thumbnail display is cancelled and replaced with menu display.

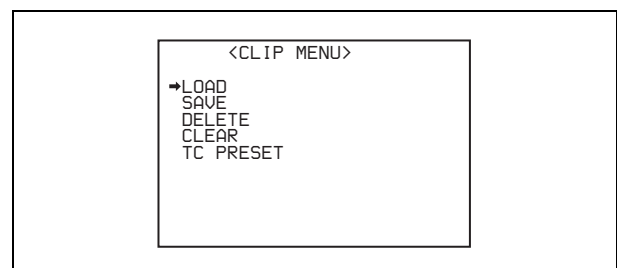

- 2 Use the SEL/SET dial or the MENU knob to move the cursor to LOAD, and press the dial/knob.

A list of the clip lists on the disc appears.

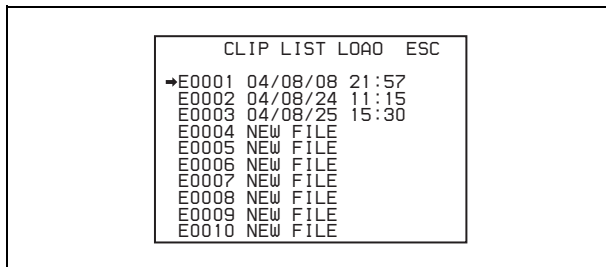

- 3 Select the desired clip list (except for NEW FILE), and press the SEL/SET dial or the MENU knob.

The message “LOAD OK? YES ▶ NO” appears.

- 4 Turn the SEL/SET dial or the MENU knob to move the ▶ mark to “YES” and press the dial/knob.

The selected clip list is loaded into the current clip list.

- 5 Hold down the SHIFT button and press the SUB CLIP button.

CLIP menu operations end.

Moving a sub clip

Proceed as follows.

- 1 Press the SUB CLIP button, turning on the indicator.
- 2 Press the THUMBNAIL button, turning on the indicator.

Thumbnails of the sub clips within the current clip list appear.

Notes

- If the MENU ON/OFF switch is set to ON, set it to OFF and press the THUMBNAIL button.
- If you set the MENU ON/OFF to ON during thumbnail display, thumbnail display is cancelled and replaced with menu display.



To escape from the thumbnail display to the full-screen display

Press the THUMBNAIL button, turning off the indicator.

- 3 Use the SEL/SET dial or the MENU knob to select the desired sub clip.
- 4 Hold down the SHIFT button, and press the SEL/SET dial.

The sub clip operation menu appears.



To return to the thumbnail display without moving the sub clip

Do either of the following.

- Use the SEL/SET dial or the MENU knob to select EXIT, and press the dial/knob.
- Press the RESET button.

- 5 Use the SEL/SET dial or the MENU knob to select MOVE, and press the dial/ knob.

The sub clip movement screen appears. The sub clip selected in step 3 appears surrounded by a frame.

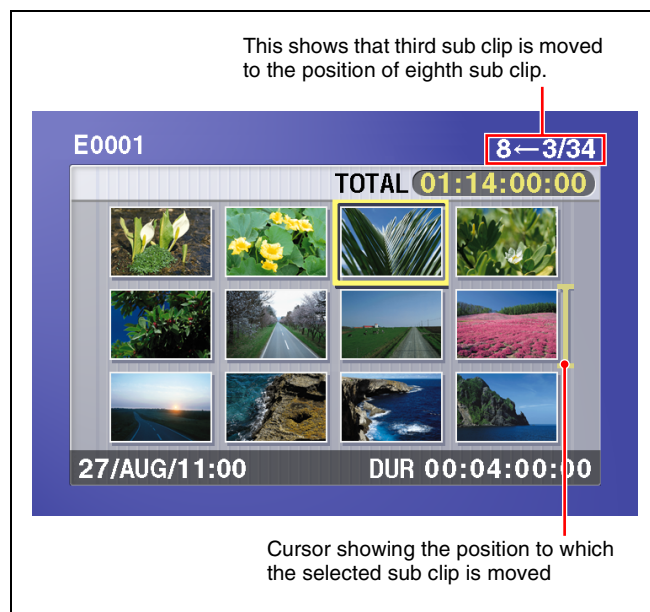

To escape from the sub clip movement screen to the previous screen

Press the RESET button.

- 6 Use the SEL/SET dial or the MENU knob to move the cursor to the position where you want to move the selected sub clip.

Note

You can press the THUMBNAIL button to return to full-screen sub clip display, without moving a sub clip.

- 7 Press the SEL/SET dial or the MENU knob.

The sub clip thumbnail display appears, and you can check the new position of the sub clip.



Trimming a sub clip

Proceed as follows.

- 1 Carry out steps 1 to 4 in the procedure, “Moving a sub clip” above.
- 2 Use the SEL/SET dial or the MENU knob to select TRIM, and press the dial/knob.

The first frame of the selected sub clip appears. In this state, you can carry out playback and search all clips on the disc.



To cancel the trim and escape from the sub clip trim screen

Hold down the SHIFT button and press the SEL/SET dial.

- 3 Carry out playback and search to find the new location of the IN point or OUT point of the selected sub clip.

- 4 At the point where you want to set the new IN point or OUT point, select the IN (when changing the IN point) or the OUT (when changing the OUT point), and press the SEL/SET dial or the MENU knob.

To change both the IN point and the OUT point, repeat steps 3 and 4.

New sub clips are created if the IN and OUT points span several clips after the change. The number of new sub clips equals the number of clips.

To reset the IN point or OUT point, selecting IN or OUT, hold down the RESET button and press the SEL/SET dial.

To cue up the IN point or OUT point, hold down the SHIFT button and press the NEXT or PREV button.

Note

You can press the THUMBNAIL button to return to full-screen sub clip display, without trimming a sub clip.

- 5 When the new IN and/or OUT points are set, hold down the SHIFT button and press the SEL/SET dial.

This carries out the trimming, and the screen returns to the sub clip thumbnail display.



To cancel the trim operation

Reset the IN point and the OUT point to return to the state before the sub clip trimming screen was displayed, then hold down the SHIFT button and press the SEL/SET dial.

This cancels the trim, and the screen returns to the sub clip thumbnail display.

Deleting a sub clip

Proceed as follows.

- 1 Carry out steps 1 to 4 in the procedure, “Moving a sub clip” (page 64).
- 2 Use the SEL/SET dial or the MENU knob to select DELETE, and press the dial/knob.

The sub clip deletion screen appears.

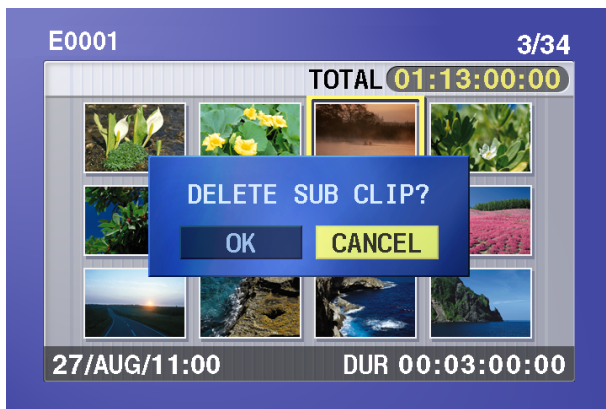

To cancel the deletion, and escape from the sub clip deletion screen

Do either of the following.

- Select CANCEL, and press the SEL/SET dial or the MENU knob.
- Press the RESET button.

The screen returns to the sub clip thumbnail display.

- 3 Use the SEL/SET dial or the MENU knob to select OK, and press the dial/knob.

This deletes the sub clip, and the screen returns to the sub clip thumbnail display.



Saving edited clip lists to disc

The operations described above (moving, trimming, and deleting sub clips) are carried out on the current clip list. Execute the procedure in 4-3-2 “Saving the Current Clip List to Disc” (page 66) to save the current clip list to disc again as a clip list.

Note

Unless the current clip list has been saved to disc, its contents will be lost when the camcorder is powered off or the disc is ejected. After creating a clip list, be sure to save it.

4-3 Clip List Operations

4-3-1 Displaying the CLIP Menu

Proceed as follows.

Note

The CLIP menu can handle up to 99 clip lists.

With the thumbnail indicator off, hold down the SHIFT button and press the SUB CLIP button.

The CLIP menu appears.

Notes

- If the MENU ON/OFF switch is set to ON, set it to OFF, then press the SUB CLIP button with the SHIFT button held down.
- If you set the MENU ON/OFF switch to ON while the CLIP menu is being displayed, thumbnail display is cancelled and replaced with menu display.

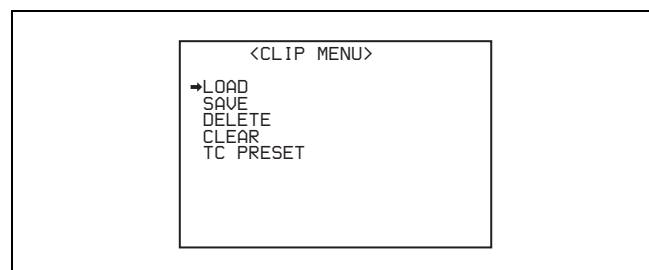

Use this menu to carry out the following operations.

- Save the current clip list to disc.
- Load a clip list on disc into the current clip list.
- Delete a clip list from disc.
- Clear the current clip list.
- Set the start time code of the current clip list.

4-3-2 Saving the Current Clip List to Disc

Proceed as follows.

- 1 Use the SEL/SET dial or the MENU knob to select SAVE in the CLIP menu, and press the dial/knob.

A list of clip lists appears.

“NEW FILE” is shown for lists which do not exist on the disc, having names only.

CLIP LIST SAVE		
E0001	04/08/08	21:57
E0002	04/08/24	11:15
E0003	04/08/25	15:30
→E0004	NEW FILE	
E0005	NEW FILE	
E0006	NEW FILE	
E0007	NEW FILE	
E0008	NEW FILE	
E0009	NEW FILE	
E0010	NEW FILE	

The date of creation or the title of each clip list is shown in the list of clip lists. To switch between the date and the title, hold down the SHIFT button and press the SEL/SET dial or the MENU button. (The date of creation is always shown for clip lists without titles.)

- Use the SEL/SET dial or the MENU knob to select the desired clip list name, and press the dial/knob.

The message “SAVE OK? YES → NO” appears.

- Turn the SEL/SET dial or the MENU knob to move the → mark to “YES” and press the dial/knob.

The current clip list is saved to disc.

- Hold down the SHIFT button and press the SUB CLIP button.

CLIP menu operations end.

4-3-3 Loading a Clip List From Disc Into the Current Clip List

Proceed as follows.

- In the CLIP menu, move the cursor to LOAD and press the SEL/SET dial or the Menu Knob.

A list of clip lists appears.

CLIP LIST LOAD ESC		
→E0001	04/08/08	21:57
E0002	04/08/24	11:15
E0003	04/08/25	15:30
E0004	NEW FILE	
E0005	NEW FILE	
E0006	NEW FILE	
E0007	NEW FILE	
E0008	NEW FILE	
E0009	NEW FILE	
E0010	NEW FILE	

The date of creation or the title of each clip list is shown in the list of clip lists. To switch between the date and the title, hold down the SHIFT button and press the SEL/SET dial or the MENU button. (The date of creation is always shown for clip lists without titles.)

- Select the desired clip list and press the SEL/SET dial or the MENU knob.

The message “LOAD OK? YES → NO” appears.

- Turn the SEL/SET dial or the MENU knob to move the → mark to “YES” and press the dial/knob.

The selected clip list is loaded into the current clip list.

- Hold down the SHIFT button and press the SUB CLIP button.

CLIP menu operations end.

- To check the contents of the loaded clip list, press the SUB CLIP button and the THUMBNAIL button, turning on the indicators.

Thumbnails of the sub clips in the clip list appear.

Notes

- If the MENU ON/OFF switch is set to ON, set it to OFF and press the THUMBNAIL button.
- If you set the MENU ON/OFF to ON during thumbnail display, thumbnail display is cancelled and replaced with menu display.
- Unless the current clip list has been saved to disc, its contents will be lost when you load a new clip list from the disc.

4-3-4 Deleting Clip Lists From Disc

Proceed as follows.

- Select DELETE in the CLIP menu, and press the SEL/SET dial or the MENU knob.

A list of clip lists appears.

The date of creation or the title of each clip list is shown in the list of clip lists. To switch between the date and the title, hold down the SHIFT button and turn the SEL/SET dial or the MENU button. (The date of creation is always shown for clip lists without titles.)

- Select the name of the clip list to delete and press the SEL/SET dial or the MENU knob.

The message “DELETE OK? YES → NO” appears.

- Turn the SEL/SET dial or the MENU knob to move the → mark to “YES” and press the dial/knob.

The selected clip list is deleted from the disc.

- Hold down the SHIFT button and press the SUB CLIP button.

CLIP menu operations end.

4-3-5 Clearing the Current Clip List

Proceed as follows to clear the current clip list, leaving it with no clip list loaded.

- 1 Select CLEAR in the CLIP menu, and press the SEL/SET dial or the MENU knob.

The following screen display appears.

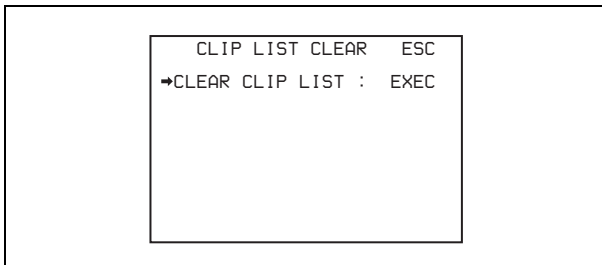

- 2 Press the SEL/SET dial or the Menu knob.

The message “EXECUTE OK? YES → NO” appears.

- 3 Turn the SEL/SET dial or the MENU knob to move the → mark to “YES” and press the dial/knob.

The current clip list is cleared, leaving it with no clip list loaded.

- 4 Hold down the SHIFT button and press the SUB CLIP button.

CLIP menu operations end.

4-3-6 Setting the Start Time code of the Current Clip List

The start time code (LTC) of the current clip list is set to 00:00:00:00 when the camcorder is powered on and when a disc is inserted.

You can set the start time code to any value. Proceed as follows.

- 1 Select TC PRESET in the CLIP menu, and press the SEL/SET dial or the MENU knob.

The following screen display appears.

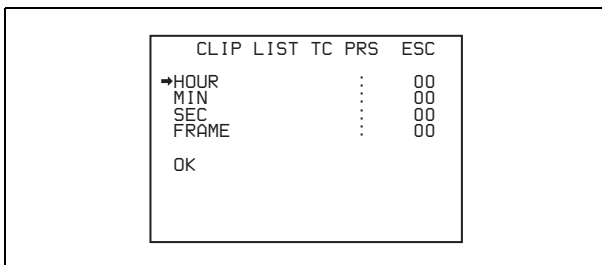

- 2 Turn the SEL/SET dial or the Menu knob to select the item (HOUR, MIN, SEC, or FRAME) which you want to set, then press the dial/knob.

- 3 Turn the SEL/SET dial or the Menu knob until the desired value is displayed, then press the dial/knob.

- 4 After all items have been set, select OK, and press the SEL/SET dial or the MENU knob.

The starting time code of the current clip list is set to the specified LTC value. The count starts from that value when playback starts.

- 5 Hold down the SHIFT button and press the SUB CLIP button.

CLIP menu operations end.

4-4 Using the PDZ-1 Proxy Browsing Software

When a computer with the PDZ-1 Proxy Browsing Software installed is connected to this unit, you can transfer the proxy AV data and metadata files recorded on a disc to the computer. On the computer side, PDZ-1 enables you to browse the proxy AV data, add or modify metadata (titles, comments, essence marks, etc.), or create a clip list.

The modified metadata and the created clip list can then be written back to the disc loaded in this unit.

System requirements

The following are required to use PDZ-1.

- Computer: PC with Intel Pentium III CPU, at least 1 GHz
Installed memory: at least 512 MB
- Operating system: Microsoft Windows 2000 Service Pack 4 or higher, or Microsoft Windows XP Professional Service Pack 1 or higher
- Web browser: Internet Explorer 6.0 Service Pack 1 or higher
- DirectX: DirectX 8.1b or higher

To install the PDZ-1

Insert the supplied CD-ROM in the CD-ROM drive of the computer and execute the Setup.exe file, then follow the installation instructions.

For details, refer to the ReadMe file in the CD-ROM.

Notes

- Make sure that the hard disk drive on which the work folder to store the material transferred from this unit has adequate free space. The amount of proxy AV data transferred is about 1.4 GB per disc (when recording in the DVCAM format).
- To transfer files between the computer and this unit requires this unit's IP address and other network-related settings to be made.

Adjustments and Settings for Recording

Chapter

5

5-1 Setting the Recording Format (PDW-530/530P only)

Before recording with the PDW-530/530P, it is necessary to set the recording format for each of video and audio.

Video recording format: MPEG IMX 50 Mbps, 40 Mbps, 30 Mbps, or DVCAM

Audio recording format: 16-bit/48 kHz or 24-bit/48 kHz

Note

It is not possible to combine different recording formats on a single disc.

5-1-1 Setting the Video Recording Format

You can select the video recording format in a menu, from MPEG IMX 50 Mbps, MPEG IMX 40 Mbps, MPEG IMX 30 Mbps, and DVCAM.

The factory default selection is “IMX50”.

Proceed as follows.

For menu operations, see 7-1-3 “Basic Menu Operations” on page 101.

- 1 Turn on the POWER switch.
- 2 Holding down the MENU knob, move the MENU ON/OFF switch from OFF to ON.

The TOP menu appears.

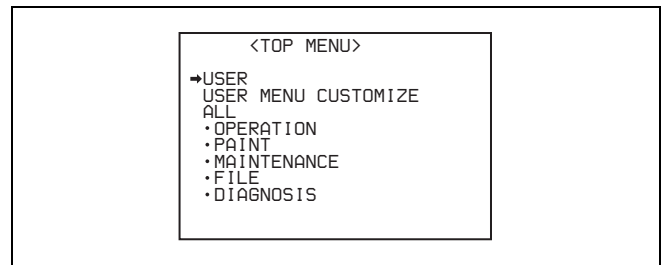

- 3 Turn the MENU knob to move the ► mark to “MAINTENANCE”.

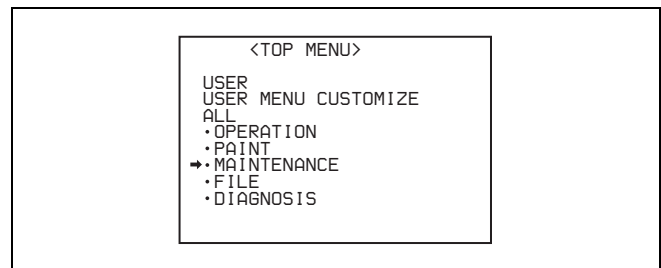

- 4 Press the MENU knob.

If this is the first time the MAINTENANCE menu has been displayed, the CONTENTS page of the MAINTENANCE menu appears.

If the menu has been used before, the last accessed page appears.

- 5 If the CONTENTS page is displayed, turn the MENU knob to move the ► mark to “VDR MODE”, and press the MENU knob to display the VDR MODE page.

If a different page is displayed, turn the MENU knob until the VDR MODE page appears, then press the MENU knob to select the page.

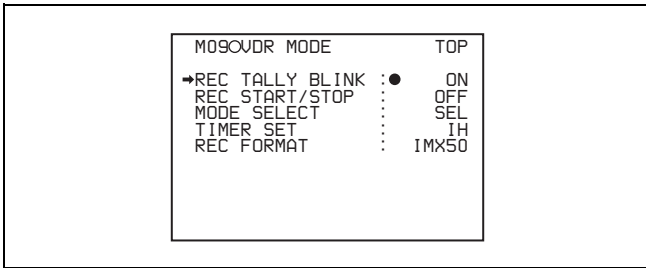

- 6** Turn the MENU knob to move the ➔ mark to “REC FORMAT”, and press the MENU knob again.

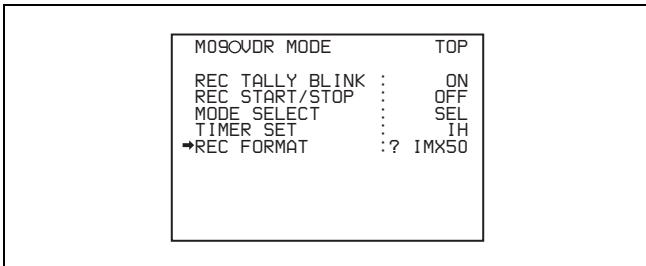

The ➔ mark at the side of “REC FORMAT” changes to a ● mark, and the ● mark by “IMX50” changes to a ? mark.

- 7** Turn the MENU knob to display the desired recording format.

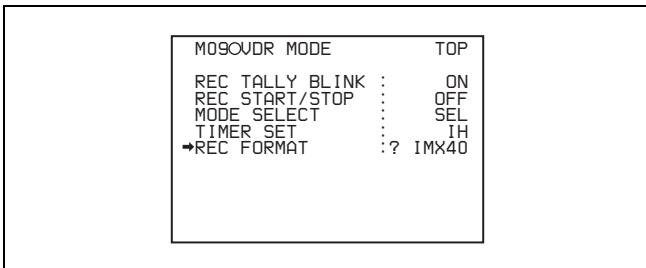

- 8** Press the MENU knob.

This confirms the selection.

- 9** Align the ➔ mark with “TOP” at the top right of the menu page, and press the MENU knob.

This returns to the TOP menu.

5-1-2 Setting the Audio Recording Format

On the PDW-530/530P, when the video recording format is IMX50/40/30, you can select the audio recording format in a menu, from 16-bit/48 kHz and 24-bit/48 kHz. The factory default selection is “16bit”.

Proceed as follows.

- 1** Display the AUDIO-2 page of the MAINTENANCE menu.

For the operation, see the descriptions of steps **1** to **5** of the procedure “Setting the Video Recording Format” on page 70.

- 2** Press the MENU knob, then turn it to move the ➔ mark to “AU DATA LEN (IMX)”, and press the MENU knob.

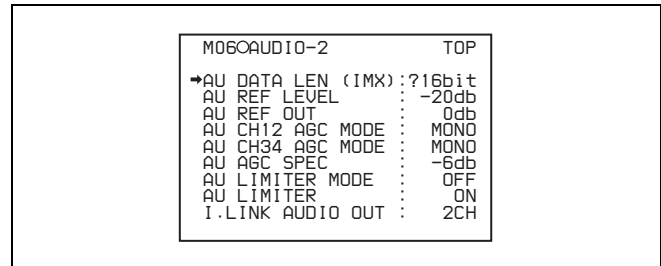

- 3** Turn the MENU knob to display the desired format, and press the MENU knob.

- 4** Move the MENU ON/OFF switch to OFF.

This ends the menu operation.

The above procedure completes the setting of the recording format.

5-2 Adjusting the Black Balance and the White Balance

To ensure excellent image quality when using this camcorder, conditions may require that both the black balance and the white balance be adjusted.

Black balance adjustment

The black balance will require adjustment in the following cases.

- When the camcorder is used for the first time
- When the camcorder has not been used for a long time
- When the camcorder is used under conditions in which the surrounding temperature has changed greatly
- When the GAIN selector (L/M/H) values have been changed by using the USER menu

It is not usually necessary to adjust the black balance when using the camcorder after it has been off.

White balance adjustment

Always readjust the white balance when the lighting conditions change.

Viewfinder screen displays

If the black balance or white balance adjustment is started, messages that report on the progress and results are displayed on the viewfinder screen when the VF DISP MODE item is set to “2” or “3” on the VF DISP 1 page of the USER menu.

Note

Black balance and white balance adjustment values that are automatically set by the camcorder and the various settings are stored in the camcorder memory and retained even when the power is turned off.

5-2-1 Adjusting the Black Balance

In automatic black balance mode, adjustments are performed in the following order: clamp level, black set, and black balance. Manual black balance adjustment can be selected from the setup menu.

Note that the automatic black balance adjustment includes a function to correct for white flecks caused in the CCDs by cosmic rays, in addition to the normal black balance operation.

For details of manual black balance adjustment, refer to the Maintenance Manual.

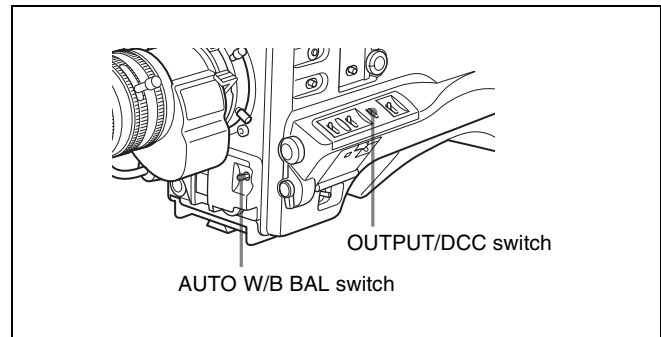

To adjust the black balance, proceed as follows.

- 1 Set the OUTPUT/DCC switch to CAM.
- 2 Push the AUTO W/B BAL switch to BLK and release the switch.

The switch returns to the center position, and the adjustment is executed.

During adjustment, the following message is displayed on the viewfinder screen.

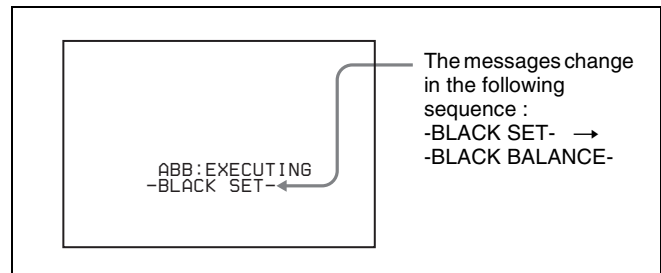

The black balance adjustment ends in a few seconds with the message “ABB:OK” and the adjustment value is automatically stored in memory.

Notes

- During the black balance adjustment, the iris is automatically closed.
- During the black balance adjustment, the gain selection circuit is automatically activated so you may see flickering on the viewfinder screen, but this is not a fault.

If automatic black balance adjustment cannot be made

If the black balance adjustment cannot be completed normally, an error message will appear for about 3 seconds on the viewfinder screen (in display mode 2 or 3). Possible messages are listed below.

Black balance adjustment error messages

Error message	Meaning
ABB : NG IRIS NOT CLOSED	The lens iris did not close; adjustment was impossible.
ABB : NG TIME LIMIT	Adjustment could not be completed within the standard number of attempts.
ABB : NG R (or G or B) : OVERFLOW	The difference between the reference value and the current value is so great that it exceeds the range. Adjustment was impossible.

If any of the above error messages is displayed, retry the black balance adjustment.

Keep pushing the AUTO W/B BAL to BLK until “-BLACK SET-” appears after “-BLACK BALANCE-” appears. If the error message occurs again, an internal check is necessary.

For information about this internal check, refer to the Maintenance Manual.

Note

If the lens cable is not firmly connected to the LENS connector, it may not be possible to adjust the lens iris. If this happens, the black balance will be incorrect.

Black balance memory

Values stored in memory are held until the black balance is next adjusted.

If a memory error occurs

If the error message “: STORED DATA : NG” flashes on the viewfinder screen when the camcorder is turned on, the black balance and white balance memory contents have been lost.

Adjust the black balance and white balance again. Contact your Sony representative if this message continues to appear even after the black balance and white balance have been adjusted again.

For details, refer to the Maintenance Manual.

5-2-2 Adjusting the White Balance

To automatically adjust the white balance

When you make automatic white balance adjustment, the adjustment value obtained is saved in memory. Proceed as follows.

- 1 Set the switches and selectors as shown in the figure below.

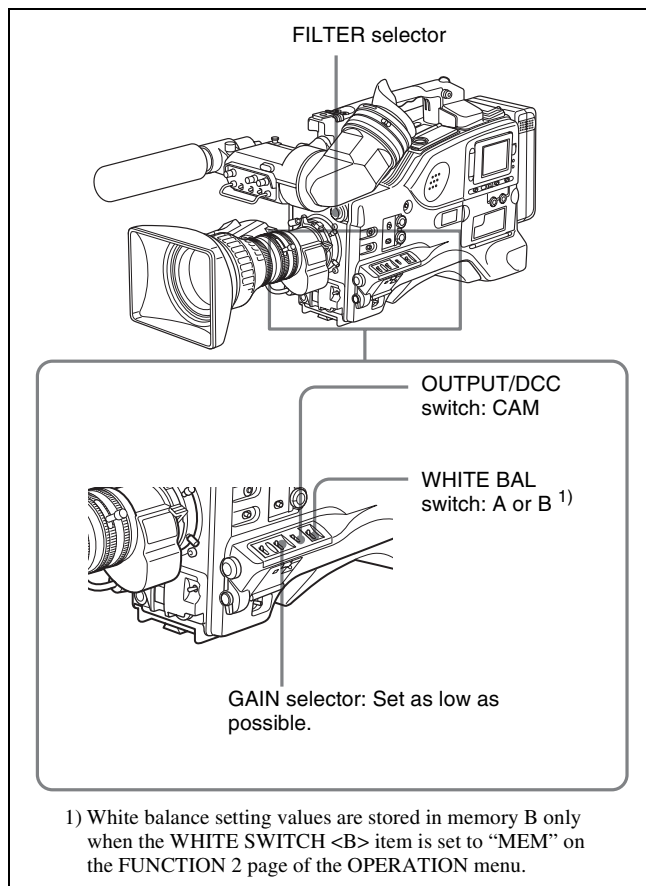

If the setting of the GAIN selector or WHITE BAL switch is changed, a message reporting the new setting position appears for about 3 seconds in the setting change and adjustment progress message display area of the viewfinder screen.

- 2 Set the FILTER selector to suit the lighting conditions as follows.

For the PDW-530/530P:

FILTER selector (outer knob) setting and CC filter selection

FILTER selector (outer knob) setting	CC filter
A	Cross filter
B	3200 K
C	4300 K
D	6300 K

FILTER selector (inner knob) setting and ND filter selection

FILTER selector (inner knob) setting	ND filter
1	Clear
2	1/4 ND
3	1/16 ND

FILTER selector (inner knob) setting and ND filter selection

FILTER selector (inner knob) setting	ND filter
4	1/64 ND

**For the PDW-510/510P:
FILTER selector setting and filter selection**

FILTER selector setting	Filter selection
1	3200 K
2	5600 K + 1/8 ND
3	5600 K
4	5600 K + 1/64 ND

If the setting of the FILTER selector is changed, a message reporting the setting appears for about 3 seconds in the setting change and adjustment progress message display area of the viewfinder screen (in display mode 3).

- Place a white test card under the same lighting conditions as for the subject to be shot and zoom up to it.

Alternatively, any white object such as a cloth or a wall can be used.
The absolute minimum white area is as follows.

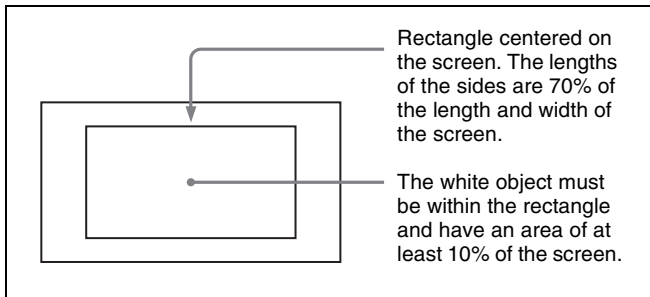

Note

Make sure there are not bright spots in the rectangle.

- Adjust the lens iris.

Manually adjusted lens: set the iris to an appropriate setting.

Lens with automatic iris: set the automatic/manual switch on the lens to automatic.

- Push the AUTO W/B BAL switch to WHT and then release the switch.

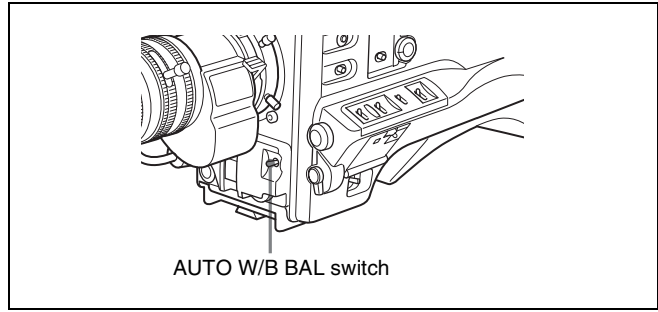

The switch returns to the center position, and the adjustment is executed.

During adjustment, the message “WHITE : OP” is displayed on the viewfinder screen (in display mode 2 or 3).

The white balance adjustment ends in about one second with the message shown in the following figure, and the adjustment setting is automatically stored in the memory (A or B) that was selected in step 1.

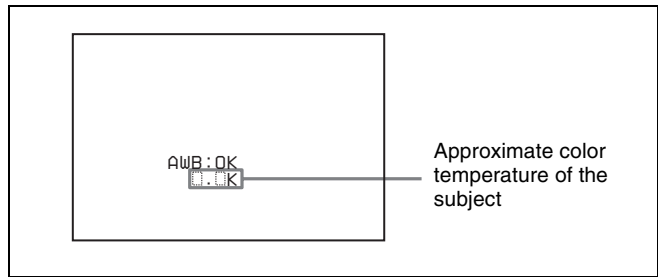

Note

If the camera has a zoom lens with an automatic iris, the iris may hunt ¹⁾ during the adjustment. To prevent this, adjust the iris gain knob (indicated as IG, IS, or S) on the lens.

For details, refer to the lens operation manual.

¹⁾Hunting

Repeated brightening and darkening of the image, resulting from repeated response to automatic iris control.

If the automatic white balance adjustment cannot be made

If the white balance adjustment cannot be completed normally, an error message will appear for about 3 seconds on the viewfinder screen.

Possible messages are listed below.

White balance adjustment error messages

Error message	Meaning
WHITE : NG LOW LEVEL	The white video level is too low. Either open the lens iris or increase the gain.

Error message	Meaning
WHITE : NG COLOR TEMP HIGH	The color temperature is too high. Select a suitable filter setting.
WHITE : NG COLOR TEMP LOW	The color temperature is too low. Select a suitable filter setting.
WHITE : NG TIME LIMIT	Adjustment could not be completed within the standard number of attempts.
WHITE : NG POOR WHITE AREA	The white area could not be checked.
WHITE : NG OVER LEVEL	The white video level is too high. Either stop down the lens iris or change the ND filter.

If any of the above error messages is displayed, retry the white balance adjustment. If the error message occurs again, an internal check is necessary.

For information about this internal check, refer to the Maintenance Manual.

If you have no time to adjust the white balance

Set the WHITE BAL switch to PRST.

The white balance is automatically set as follows, depending on the FILTER selector setting.

- PDW-530/530P:
B: 3200K, C: 4300 K, D: 6300K
- PDW-510/510P:
1: 3200 K, 3: 5600 K

For details about setting the white balance manually, see “To automatically adjust the white balance” on page 73.

White balance memory

Values stored in memory are held until the white balance is next adjusted.

There are two sets of white balance memories, A and B, and adjustments for each of the filters can be automatically stored in the memory corresponding to the setting (A or B) of the WHITE BAL switch. The camcorder has four built-in filters, so a total of eight (4 × 2) adjustments can be stored. The number of memories allocated to each of A and B can be limited to one by setting the WHT FILTER INH. item to “ON” on the FUNCTION 3 page of the MAINTENANCE menu. In this case, the memory contents are not linked to the filter settings.

If the WHITE BAL switch is set to B, and on the FUNCTION 2 page of the OPERATION menu, the WHITE SWITCH item is set to “ATW”, the ATW function is activated to automatically adjust the white balance of the picture being shot for varying lighting conditions.

If a memory error occurs

If the error message “: STORED DATA : NG” flashes on the viewfinder screen when the camcorder is turned on, the white balance and black balance memory contents have been lost.

Adjust the white balance and black balance again. Contact your Sony representative if this message continues to appear even after the white balance and black balance have been adjusted again.

For details, refer to the Maintenance Manual.

5-3 Setting the Electronic Shutter

This section describes the shutter modes that can be used with the electronic shutter of the camcorder, and describes the procedure for selecting the shutter speed and shutter mode.

5-3-1 Shutter Modes

The shutter modes that can be used with the electronic shutter and the shutter speeds that can be selected are listed below.

Selectable shutter modes and shutter speeds

Shutter mode	Shutter speed		Application
Standard	PDW-510/530	Scan Mode:I 1/100, 1/125, 1/250, 1/500, 1/1000, 1/2000 (sec.) Scan Mode:PsF 1/40, 1/60, 1/120, 1/125, 1/250, 1/500, 1/1000, 1/2000 (sec.) Scan Mode:24P ¹⁾ 1/32, 1/48, 1/96, 1/125, 1/250, 1/500, 1/1000, 1/2000 (sec.):	For shooting fast-moving subjects with little blurring.
	PDW-510P/530P	Scan Mode:I 1/60, 1/125, 1/250, 1/500, 1/1000, 1/2000 (sec.) Scan Mode:PsF 1/33, 1/50, 1/100, 1/125, 1/250, 1/500, 1/1000, 1/2000 (sec.)	
ECS (Extended Clear Scan)	PDW-510/530	Scan Mode:I 60.0 to 6000 Hz Scan Mode:PsF 30.0 to 7000 Hz Scan Mode:24P ¹⁾ 24.0 Hz to 5000 Hz	For obtaining images with no horizontal bands of noise when shooting subjects such as monitor screens.
	PDW-510P/530P	Scan Mode:I 50.0 to 6000 Hz Scan Mode:PsF 25.0 to 6000 Hz	
SLS ²⁾ (slow speed shutter)	1 (1/30 sec for PDW-510/530, 1/25 sec for PDW-510P/530P) to 8, 16 frames (1/2 sec for PDW-510/530, 2/3 sec for PDW-510P/530P)		For shooting subjects in low level lighting conditions

Shutter mode	Shutter speed	Application
EVS (Enhanced Vertical definition System)	Shutter speed currently selected in the Standard or ECS mode	Improved vertical resolution. However, the sensitivity and dynamic range are reduced.

1) Only when the CBK-FC01 is installed.

2) The SLS mode can only be selected when the CCD scan mode(see page 124) is set to "I (interlace scan)".

Notes

- Whatever the operating mode of the electronic shutter, the sensitivity of the CCD decreases with increasing shutter speed.
- When the automatic iris is used, the iris opens wider as the shutter speed increases, thus reducing the depth of field.
- Under artificial light, particularly fluorescent or mercury lamps, the light intensity may appear to be constant, but the red, green, and blue intensities are actually changing in synchronization with the frequency of the power supply causing flicker. Using an electronic shutter under such lighting could make the flicker even worse. Color flicker is particularly likely to happen when the power supply frequency is 60 Hz (with the PDW-510/530) or 50 Hz (with the PDW-510P/530P). However, if the power frequency is 50 Hz (with the PDW-510/530) or 60 Hz (with the PDW-510P/530P), setting the shutter speed to 1/100 or 1/60 can reduce this flicker.
- When a bright object is shot in EVS mode or ECS mode in such a manner that it fills the screen, the upper edge of the picture may have poor quality because of an inherent characteristic of CCDs. Before using EVS mode or ECS mode, check the shooting conditions.

You can turn on or off the EVS mode on the SW STATUS page of the PAINT menu.

5-3-2 Selecting the Shutter Mode and Shutter Speed

Use the SHUTTER selector to select a shutter mode or a standard-mode shutter speed. To set the shutter speed in ECS or SLS mode, with the SHUTTER selector set to ON and the ECS or SLS mode selected, use the MENU knob for adjustment.

You can use the SHT ENABLE page of the OPERATION menu to narrow the range of choice in advance, or to select in advance whether or not you use ECS/SLS.

Setting the shutter mode and standard-mode shutter speed

Once the shutter speed is selected, it is retained even when the camcorder power is turned off.

- 1 Follow the procedure described in 7-2-2 “*Selecting the Display Items*” (page 109) to set the VF DISPLAY MODE item to “2” or “3” on the VF DISP 1 page of the USER menu.
- 2 Push the SHUTTER selector from ON to SELECT.

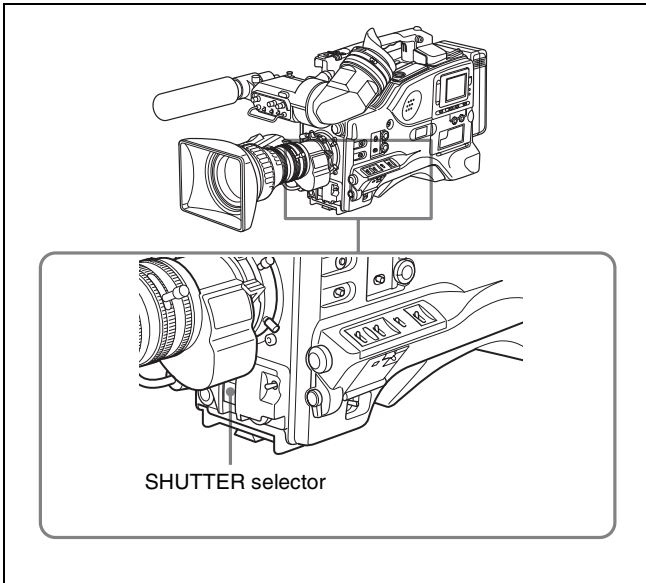

The current shutter setting indication appears for about 3 seconds in the setting change and adjustment progress message display area of the viewfinder screen.

Examples: “: SS : 1/250”, “: SLS : 1/30 : 1FRAME”, “: ECS : 60.0 Hz”

- 3 Before the shutter setting indication disappears, push the SHUTTER selector down to SELECT again and repeat this until the desired mode or speed appears.

Pushing the SHUTTER selector down to SELECT repeatedly allows you to cycle through the settings of mode and speed preselected on the SHT ENABLE page of the OPERATION menu.

Note that all modes and all standard-mode speeds listed in the table on page 76 are preselected using the SHT ENABLE page of the OPERATION menu. By factory default, all available shutter modes and shutter speeds are displayed in the sequence shown in the following figure. (You can use the SHT ENABLE page of the OPERATION menu to make a setting so that only the desired (or most frequently used) modes and speeds are displayed.)

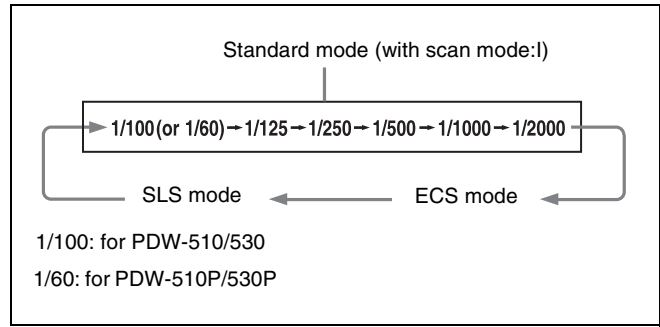

Shutter speeds in standard mode can also be switched to angle display by using SHT DISP MODE in the FUNCTION 3 page of the MAINTENANCE menu.

Setting the shutter speed in ECS mode

Proceed as follows.

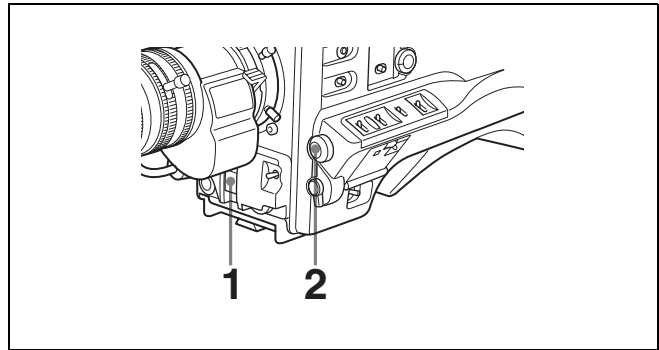

Setting the shutter speed in ECS (Extended Clear Scan) mode

- 1 Set the shutter speed mode to ECS.

For the operation, see the previous item “*Setting the shutter mode and standard-mode shutter speed*”.

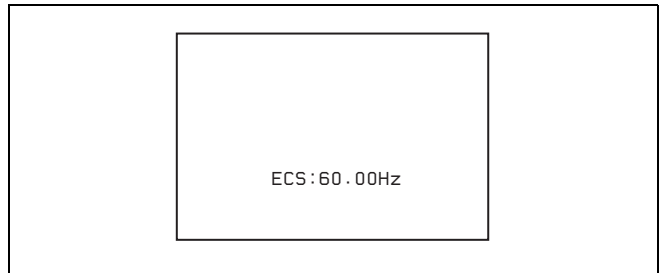

Example of view finder screen display for ECS setting operation

- 2 Turn the MENU knob clockwise or counterclockwise until the desired frequency appears.

See the table “*Selectable shutter modes and shutter speeds*” (page 76) for the frequency range which can be changed.

When the RM-B150 Remote Control Unit is connected

You can set the shutter speed of ECS with the rotary encoder of the RM-B150.

Setting the shutter speed in SLS mode

Proceed as follows.

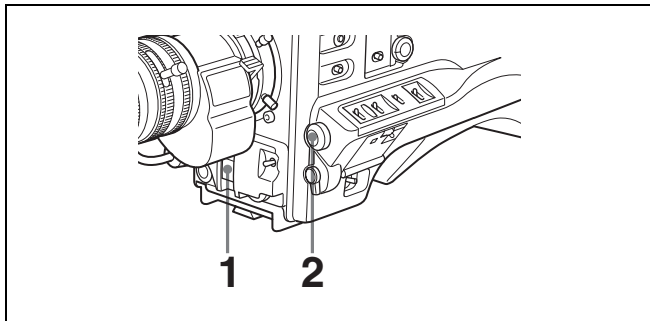

Setting the shutter speed in SLS (Slow Speed Shutter) mode

- 1 Set the shutter speed mode to SLS.

For the operation, see “Setting the shutter mode and standard-mode shutter speed” on page 77.

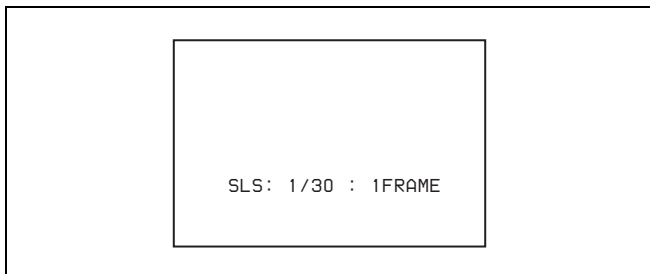

Example of viewfinder screen display for SLS setting operation

- 2 Turn the MENU knob until the desired number of frames appears.

The number of frames can be set to values in the range 1 to 8, and 16. (1 frame nearly equals to 1/30 second (PDW-510/530) or 1/25 second (PDW-510P/530P)).

Changing the range of choice of shutter mode and speed settings

You can reduce the time required to select the shutter mode and speed by narrowing the choice of settings in advance. This can be done by using the SHT ENABLE page of the OPERATION menu.

Proceed as follows.

Note

The settings selected on the SHT ENABLE page of the OPERATION menu become invalid when the RM-B150 Remote Control Unit is connected to the camcorder.

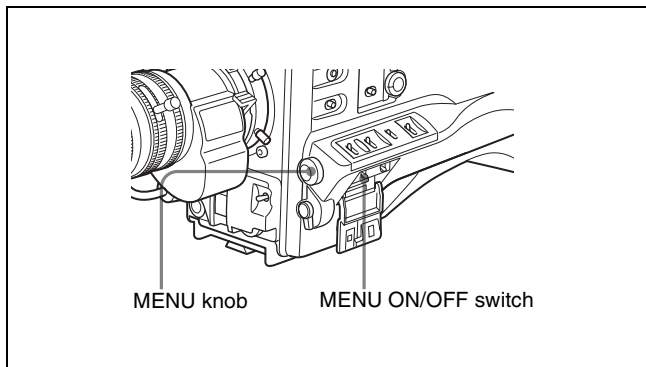

Changing the range of choice of shutter mode and speed settings

- 1 Set the MENU ON/OFF switch to ON while holding down the MENU knob.

The TOP menu appears.

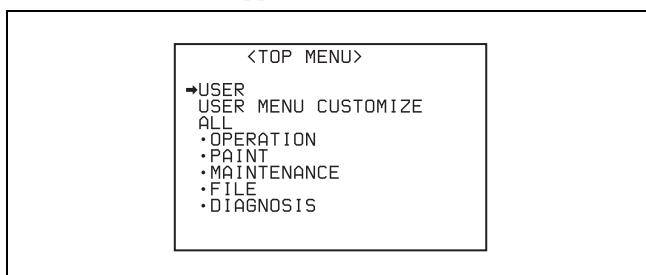

- 2 Turn the MENU knob to move the ► mark to OPERATION.

- 3 Press the MENU knob.

If this is the first time the OPERATION menu has been displayed, the CONTENTS page of the OPERATION menu appears. If the menu has been used before, the last accessed page appears.

- 4 If the CONTENTS page is displayed, turn the MENU knob to move the ► mark to “SHT ENABLE”, then press the MENU knob to display the SHT ENABLE page.

If a different page is displayed, turn the MENU knob until the SHT ENABLE page appears, then press the MENU knob to select the page.

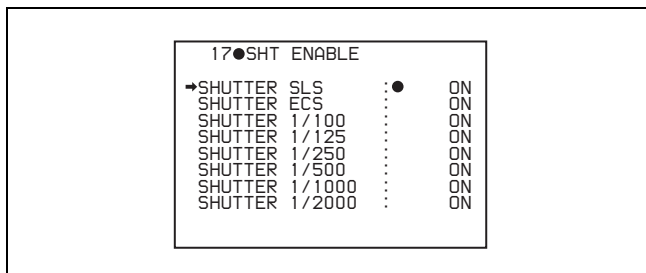

(This menu display is for the PDW-510/530. For the PDW-510P/530P, “SHUTTER 1/60” is displayed instead of “SHUTTER 1/100”.)

- 5** Turn the MENU knob to move the ➔ mark to the shutter mode or shutter speed you want, then press the MENU knob.

The ➔ mark on the left of the selected item changes to a ● mark and the ● mark on the left of the setting changes to a ? mark.

- 6** Turn the MENU knob until “ON” appears, then press the MENU knob.

The ● mark on the left of the selected item changes to a ➔ mark and the ? mark on the left of the setting changes to a ● mark.

To set another mode or speed, return to step 5.

Note that only the shutter speeds set to “ON” can be selected with the SHUTTER selector.

- 7** To end the menu operation, set the MENU ON/OFF switch to OFF or close the cover of the menu operating section.

The menu disappears from the screen and the display indicating the current status of the camcorder appears along the top and bottom of the screen.

5-4 Changing the Reference Value for Automatic Iris Adjustment

The reference value for automatic iris adjustment can be changed to aid the shooting of clear pictures of back-lit subjects, or to prevent blown-out highlights. The reference value for the lens iris can be set within the following range with respect to the standard value.

- 0.5: about 0.5 stop further open
- 1: about 1 stop further open
- -0.5: about 0.5 stop further closed
- -1: about 1 stop further closed

Also you can set the area where light detection occurs.

Changing the reference value

Proceed as follows.

- 1** Set the MENU ON/OFF switch to ON.

If this is the first time the USER menu has been displayed, the CONTENTS page of the USER menu appears. If the menu has been used before, the last accessed page appears.

- 2** If the CONTENTS page is displayed, turn the MENU knob to move the ➔ mark to AUTO IRIS, then press the MENU knob to display the AUTO IRIS page.

If a different page is displayed, turn the MENU knob until the AUTO IRIS page appears, then press the MENU knob to select the page.

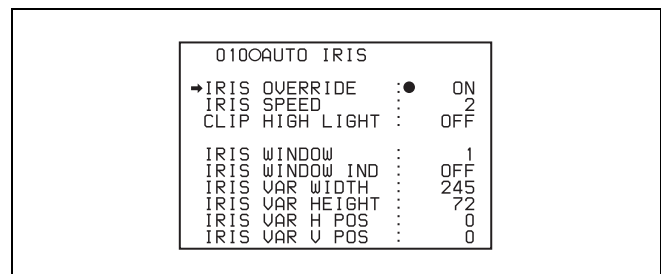

- 3** Turn the MENU knob to move the ➔ mark to “IRIS OVERRIDE”, then press the MENU knob.

The ➔ mark on the left of the selected item changes to a ● mark and the ● mark on the left of the setting changes to a ? mark.

- 4** Turn the MENU knob until “ON” appears, then press the MENU knob.

The ● mark on the left of the selected item changes to a ➔ mark and the ? mark on the left of the setting changes to a ● mark.

The IRIS OVERRIDE item is set to “ON”.

5 Set the MENU ON/OFF switch to OFF.

The AUTO IRIS page disappears from the screen.

6 Turn the MENU knob to change the reference value.

Note

Be sure to confirm that the current shutter mode is not ECS.

The changed reference value is retained until the power of the camcorder is turned off. Even if the reference value is changed, it reverts to the standard value every time the power is turned on.

To open the iris by 0.5 stop:

Turn the MENU knob counterclockwise as seen from the front of the camera.

One bar (□) appears in the upper part to the left of the F number in the iris indication.

To open the iris by 1 stop:

Turn the MENU knob counterclockwise as seen from the front of the camera.

Two bars (□□) appear in the upper part to the left of the F number in the iris indication.

To stop down the iris by 0.5 stop:

Turn the MENU knob clockwise as seen from the front of the camera.

One bar (□) appears in the lower part to the left of the F number in the iris indication.

To stop down the iris by 1 stop:

Turn the MENU knob further clockwise as seen from the front of the camera.

Two bars (□□) appear in the lower part to the left of the F number in the iris indication.

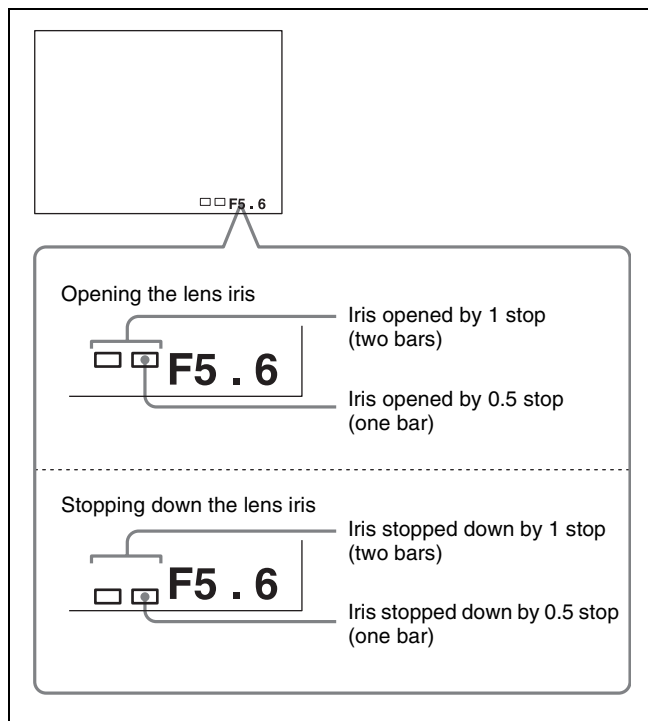

Adjusting the reference value for automatic iris adjustment

When the RM-B150 Remote Control Unit is connected

The IRIS control knob of the RM-B150 can be used for lens iris setting. In this case, the bar display (□) does not appear.

Selecting the automatic iris window

Proceed as follows.

1 Follow the procedure of steps 1 and 2 described in the previous item “Changing the reference value” to display the AUTO IRIS page.

2 Turn the MENU knob to move the ➔ mark to “IRIS WINDOW IND”, then press the MENU knob.

The ➔ mark on the left of “IRIS WINDOW IND” changes to a ● mark and the ● mark on the left of the setting changes to a ? mark.

3 Turn the MENU knob until “ON” appears, then press the MENU knob.

The ● mark changes to a ➔ mark and the ? mark changes to a ● mark.

The currently selected auto iris window appears on the screen.

If it is not necessary to display the auto iris window on the screen, set to “OFF”.

4 Turn the MENU knob to move the ➔ mark to “IRIS WINDOW”, then press the MENU knob.

The ► mark changes to a ● mark and the ● mark changes to a ? mark.

- Turn the MENU knob until the desired auto iris window appears, then press the MENU knob.

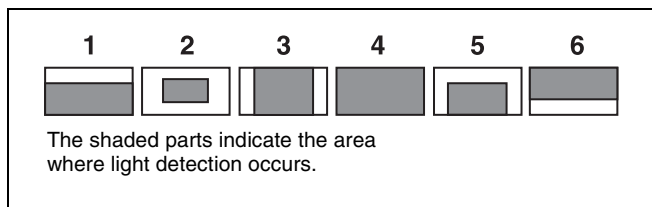

Auto iris window

The ● mark on changes to a ► mark and the ? mark changes to a ● mark.

If you select “VARIABLE”, the following items become effective and you can set the window of the desired size. Set each item to the desired size.

Item	Setting
IRIS VAR WIDTH	The width of the window
IRIS VAR HEIGHT	The height of the window
IRIS VAR H POS.	The position of the window in the horizontal direction
IRIS VAR V POS.	The position of the window in the vertical direction.

- Set the MENU ON/OFF switch to OFF or close the cover of the menu operating section.

The menu disappears from the screen and the display indicating the current status of the camcorder appears along the top and bottom of the screen.

To counter problems with very bright highlights

If the subject is too bright, the iris may close too much, leaving the overall image dark, or the highlights may be blown out. In such cases, setting the highlight clip function on reduces the luminance range, avoiding problems from the automatic iris correction.

In the AUTO IRIS page of the USER menu, set the CLIP HIGH LIGHT item to “ON”.

5-5 Adjusting the Audio Level

Setting the AUDIO SELECT CH-1/CH-2 switches to AUTO automatically adjusts the input levels of the audio signal to be recorded in audio channels 1 and 2. You can also adjust the audio level manually.

For the audio level of the signal to be recorded in audio channels 3 and 4

The input levels for audio channels 3 and 4 are either automatically adjusted, or are fixed.

5-5-1 Manually Adjusting the Audio Levels of the Audio Inputs From the AUDIO IN CH1/CH2 Connectors

Proceed as follows to adjust the audio levels of the audio inputs from the AUDIO IN CH1/CH2 connectors, which are to be recorded in audio channels 1 and 2.

With the XLR connection automatic detection function being on, when a cable is connected to the AUDIO IN CH1 or CH2 connector, the input from these connectors is automatically selected for audio recording. In this case, start the operation from step 2.

You can turn on and off the XLR connection automatic detection function on the AUDIO-1 page of the MAINTENANCE menu.

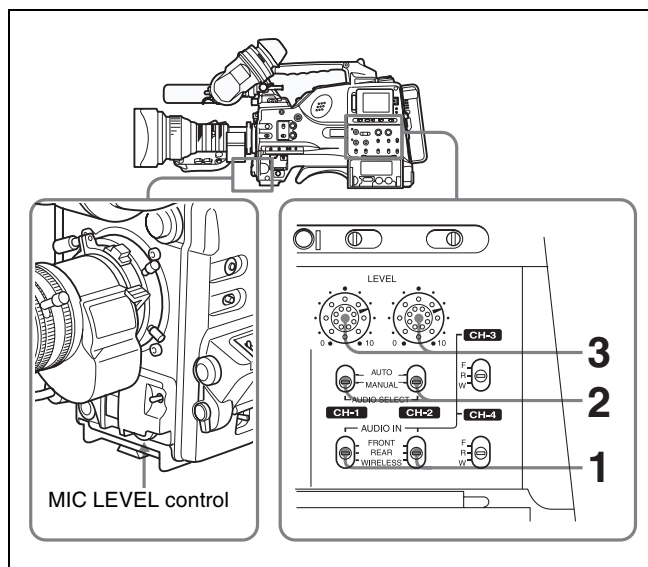

Manual adjustment of the audio levels of channels 1 and 2

- 1 To adjust the signal input to the AUDIO IN CH1 or AUDIO IN CH2 connector, set the AUDIO IN CH-1 or AUDIO IN CH-2 switch to REAR. To adjust both input signals, set both switches to REAR.
- 2 Set the AUDIO SELECT switch(es) corresponding to the channel(s) selected in step 1 to MANUAL.
- 3 With the LEVEL control for the channel selected in step 1, adjust so that the audio level meter shows up to -20 dB for a normal input volume.

The second bar from the top may turn on occasionally, but do not allow the top bar (0 dB) to go on. If it goes on, the audio level is too high.

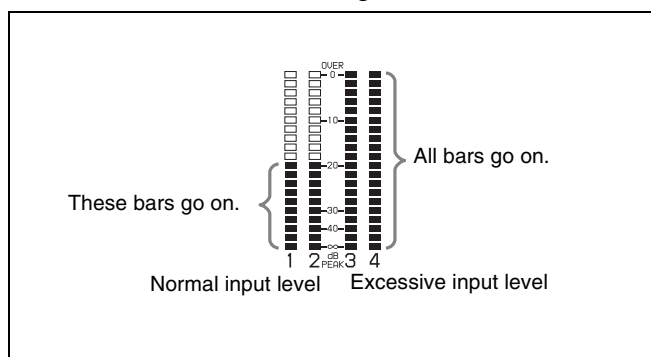

Correspondence between recording level adjustments and audio level controls

In the AUDIO-3 page of the MAINTENANCE menu, you can select which audio level control controls the audio recording level of the input to each of the AUDIO IN CH1/CH2 connectors. The correspondence between the controls and the menu items and settings is as follows.

Level to be adjusted	Control	Menu item	Setting
Channel-1 recording level	LEVEL (CH-1) control (on the left)	REAE1/WRR LEVEL	SIDE1
	MIC LEVEL control		FRONT
	LEVEL (CH-1) control is linked with MIC LEVEL control.		F+S1
Channel-2 recording level	LEVEL (CH-2) control (on the right)	REAE2/WRR LEVEL	SIDE2
	MIC LEVEL control		FRONT
	LEVEL (CH-2) control is linked with MIC LEVEL control.		F+S2

Note

When you have operation of the LEVEL (CH-1/CH-2) controls and MIC LEVEL control linked together, if the MIC LEVEL control is set to 0, the audio signals on channels 1 and 2 cannot be recorded. Check the position of the MIC LEVEL control before adjusting the LEVEL (CH-1/CH-2) controls.

5-5-2 Manually Adjusting the Audio Level of the Front Microphone

You can adjust the audio level input from the front microphone connected to the MIC IN connector, which is to be recorded on audio channels 1 and 2.

Note

If the XLR connection automatic detection mode is on, when the cables are connected to the AUDIO IN CH1/CH2 connectors, the camcorder detects the connection to the AUDIO IN CH1/CH2 connectors. Thus, the AUDIO IN switches are internally reset to REAR and the audio signals input to the AUDIO IN CH1/CH2 connectors are automatically selected.

Before adjusting the audio level of the front microphone, confirm that no cables are connected to the AUDIO IN CH1/CH2 connectors. Alternatively, set the REAR XLR AUTO item to "OFF" on the AUDIO-1 page of the MAINTENANCE menu.

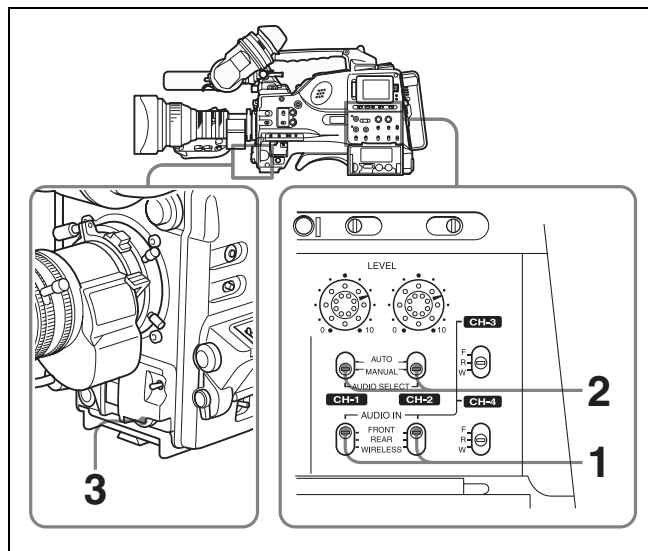

- 1 Set either or both of the AUDIO IN switch(es) to FRONT as follows:
 - When using the front microphone input for both channels 1 and 2:** Set both AUDIO IN switches to FRONT.
 - When using the front microphone input for either channel 1 or 2:** Set the AUDIO IN switch for the desired channel to FRONT.
- 2 Set the AUDIO SELECT switch(es) for the desired channel(s) selected in step 1 to MANUAL.
- 3 Turn the MIC LEVEL control, and adjust so that the audio level meter shows up to -20 dB for a normal input volume.
 - The 10 bars from the bottom among 20 bars go on with the normal input volume.

- The second top bar may turn on occasionally, but do not allow the top bar to go on. If it goes on, the audio level is too high.

Correspondence between recording level adjustments and audio level controls

In the AUDIO-3 page of the MAINTENANCE menu, you can select which audio level control controls the audio recording level of the front microphone input. The correspondence between the controls and the menu items and settings is as follows.

Level to be adjusted	Control	Menu item	Setting
Channel-1 recording level	MIC LEVEL control	MIC CH1 LEVEL	FRONT
	LEVEL (CH-1) control (on the left)		SIDE
	LEVEL (CH-1) control is linked with MIC LEVEL control.		F+S1
Channel-2 recording level	MIC LEVEL control	MIC CH2 LEVEL	FRONT
	LEVEL (CH-2) control (on the right)		SIDE2
	LEVEL (CH-2) control is linked with MIC LEVEL control.		F+S1

Note

When you have operation of the MIC LEVEL control and LEVEL (CH-1/CH-2) controls linked together, if the LEVEL (CH-1/CH-2) controls are set to 0, the audio signals on channels 1 and 2 cannot be recorded. Check the position of the LEVEL (CH-1/CH-2) controls before adjusting the MIC LEVEL control.

5-5-3 Recording Audio on Channels 3 and 4

Selecting the recorded audio

You can select the audio recorded on audio channels 3 and 4 with the AUDIO IN CH-3/CH-4 switches, or you can have the selection made automatically, as follows.

To automatically select the same audio as on channels 1 and 2

In the AUDIO-1 page of the MAINTENANCE menu, set the AUDIO CH3/4 MODE item to “CH 1/2”.

Adjusting the audio recording levels

In the AUDIO-2 page of the MAINTENANCE menu, set the AU CH34 AGC MODE item as follows.

For automatic adjustment: select “STREO” or “MONO”.

For fixed settings: select “OFF”.

Note

The type of audio recorded on audio channels 3 and 4 does not depend on the XLR connection automatic detection function. It is determined only by the switch settings.

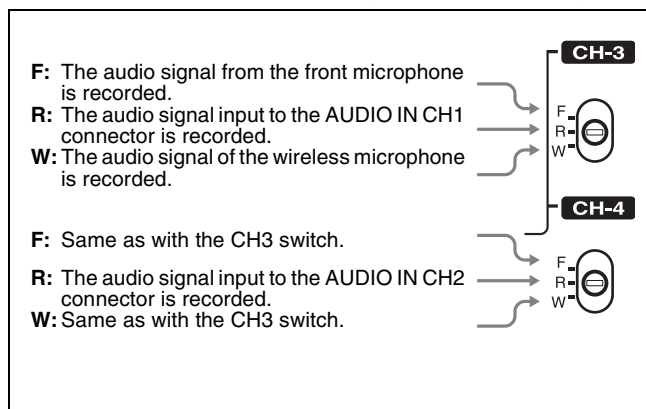

Audio signals to be recorded on audio channels 3 and 4

5-6 Setting the Time Data

5-6-1 Setting the Time Code

The time code setting range is from 00 : 00 : 00 : 00 to 23 : 59 : 59 : 29 (hours : minutes : seconds : frames) for the PDW-510/530, and from 00 : 00 : 00 : 00 to 23 : 59 : 59 : 24 for the PDW-510P/530P.

Note

When the scan mode is 24P (with the CBK-FC01 expansion board installed) and the frame mode is NDF (non-drop frame mode), the value of the least significant digit is limited to 0 or 5.

To set the time code, proceed as follows.

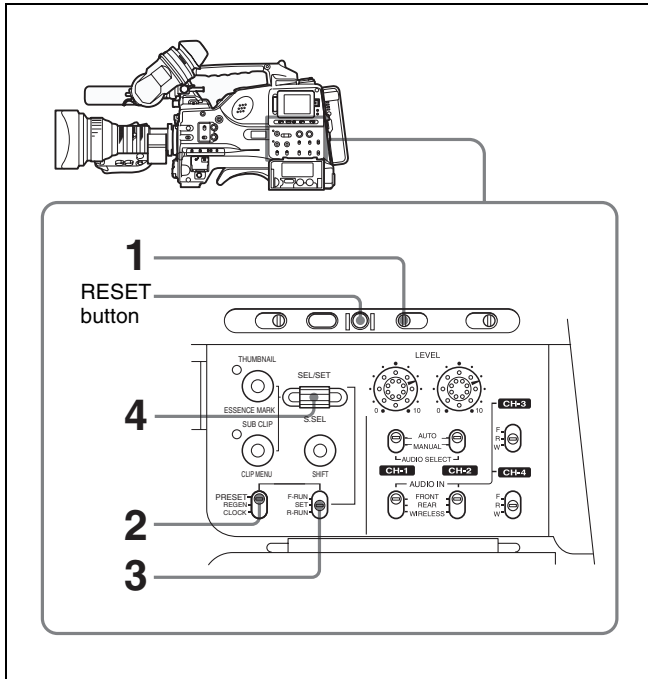

Setting the time code

- 1 Set the DISPLAY switch to TC.
- 2 Set the PRESET/REGEN/CLOCK switch to PRESET.
- 3 Set the F-RUN/SET/R-RUN switch to SET.
The first (leftmost) digit of time code flashes.
- 4 Use the SEL/SET dial to set the time code value.
To change the value of the flashing digit, turn the dial, and to shift to the next digit, press the dial. Repeat this until all desired digits are set.

To reset the time code value to 00:00:00:00

Press the RESET button.

- 5 Set the F-RUN/SET/R-RUN switch to F-RUN or R-RUN.

F-RUN: Free run. The time code generator keeps running.

R-RUN: Recording run. The time code generator runs only while recording.

To set the drop frame mode/non-drop frame mode (only for the PDW-510/530)

You can select the drop frame (DF) mode or non-drop frame (NDF) mode on the FUNCTION 1 page of the USER menu or OPERATION menu or on the TIMECODE page of the MAINTENANCE menu.

To make the time code consecutive

When the F-RUN/SET/R-RUN switch is set to R-RUN, recording a number of scenes on the disc normally produces consecutive time code. However, once you remove the disc and record on another disc, the time code will no longer be contiguous when you use again the original disc for recording. In this case, to make the time code consecutive, proceed as follows.

- 1 Set the PRESET/REGEN/CLOCK switch to REGEN.
- 2 Press the RET button on the lens.

This reads the previous recording and synchronizes the internal time code generator, thus allowing the new time code recorded to follow on consecutively.

5-6-2 Saving the Actual Time in the Time Code

Setting the PRESET/REGEN/CLOCK switch to CLOCK saves the actual time in the time code.

When it is necessary to set the actual time, use the TIME/DATE page of the DIAGNOSIS menu.

For details, see 7-3-6 “Setting the Date/Time of the Internal Clock” on page 122.

5-6-3 Setting the User Bits

By setting the user bits (up to 8 hexadecimal digits), you can record user information such as the date, time, or scene number on the time code track.

To set the user bits, proceed as follows.

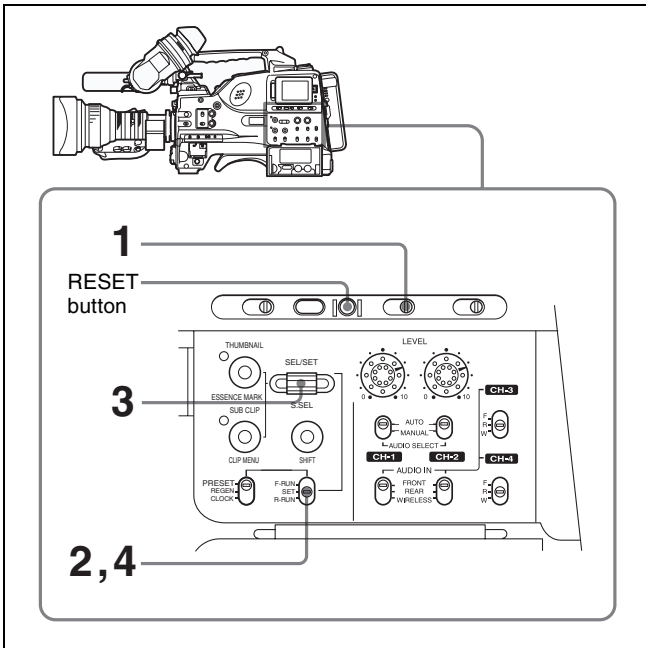

Setting the user bits

- 1 Set the DISPLAY switch to U-BIT.
- 2 Set the F-RUN/SET/R-RUN switch to SET.
The first (leftmost) digit flashes.
- 3 Use the SEL/SET dial to set the user bit data.
To change the value of the flashing digit, turn the dial, and to shift to the next digit, press the dial. Repeat this until all desired digits are set.

Hexadecimal digits A to F are displayed as follows:

Hexadecimal	A	B	C	D	E	F
Display	A	b	C	d	E	F

To reset the user bit data to 00:00:00:00
Press the RESET button.

- 4 Set the F-RUN/SET/R-RUN switch to F-RUN or R-RUN, corresponding to the desired operating mode for the time code generator.

The set user bit data will be recorded for both LTC and VITC.

To store the user bit setting in memory

The user bit setting (apart from the real time) is automatically retained in memory even when the power is turned off.

5-6-4 Synchronizing the Time Code

You can synchronize the internal time code generator of this camcorder with an external generator for the

regeneration of an external time code. You can also synchronize the time code generators of other camcorders/ VTRs with the internal generator of this camcorder.

Connections for time code synchronization

Connect both the reference video signal and the external time code as illustrated below.

Example 1: Synchronizing with an external time code

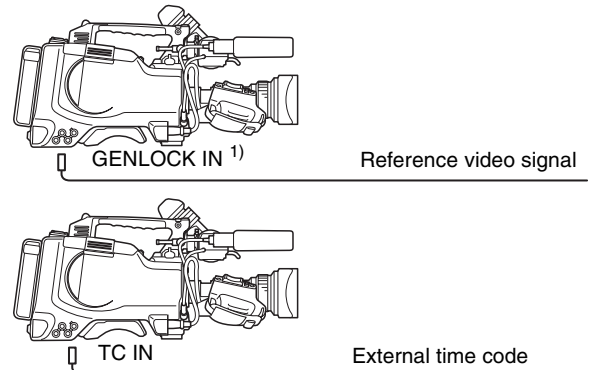

1) Set GENLOCK to ON on the GENLOCK page of the MAINTENANCE menu, if GENLOCK is set to OFF.

Example 2: Interconnecting a number of camcorders for time code synchronization

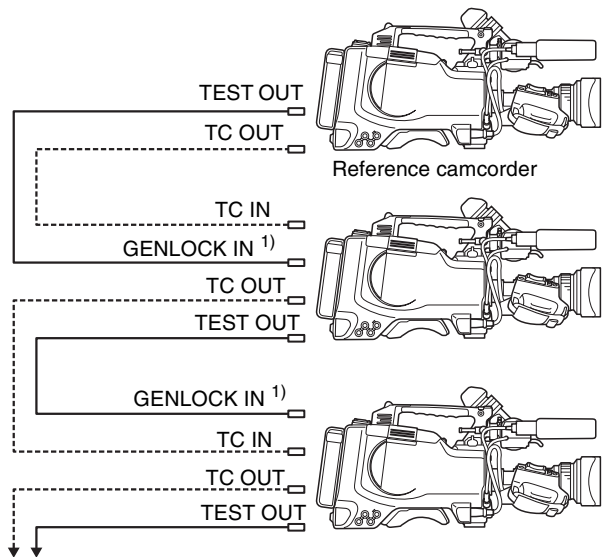

To another camcorder to be synchronized

1) Set GENLOCK to ON on the GENLOCK page of the MAINTENANCE menu, if GENLOCK is set to OFF.

Procedure for time code synchronization

To synchronize the time code, proceed as follows.

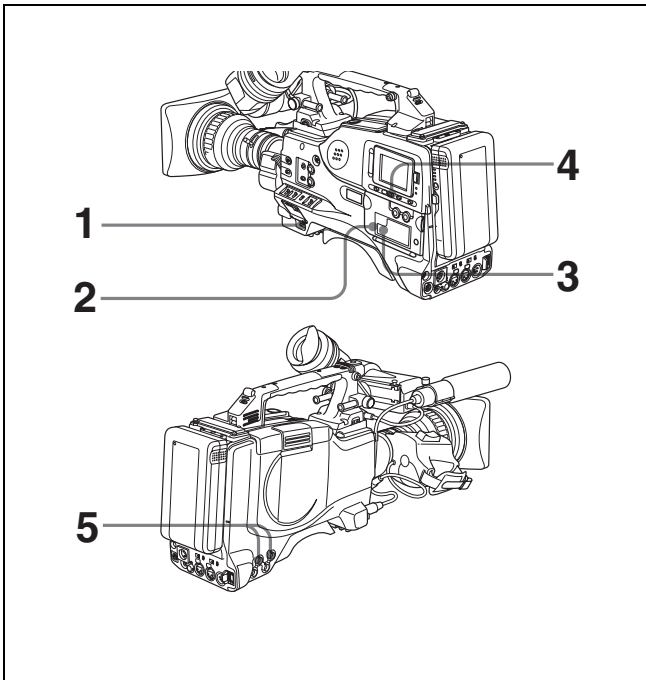

Synchronizing the time code

- 1 Turn on the POWER switch.
- 2 Set the PRESET/REGEN/CLOCK switch to PRESET.
- 3 Set the F-RUN/SET/R-RUN switch to F-RUN.
- 4 Set the DISPLAY switch to TC.
- 5 Supply a time code signal and a reference video signal complying with the SMPTE (for PDW-510/530) or EBU (for PDW-510P/530P) standard and in proper phase relationship, to the TC IN connector and to the GENLOCK IN connector, respectively.

This operation synchronizes the internal time code generator with the external time code. After about 10 seconds, you can disconnect the external time code without losing the synchronization. However, there will be noise on the recorded image if you connect or disconnect the time code signal during recording.

Notes

- When you finish the above procedure, the internal time code is immediately synchronized with the external time code and the counter display will show the value of the external time code. However, wait for a few seconds until the sync generator stabilizes before recording.
- If the frequency of the reference video signal is not the same as the frame frequency of the camcorder, the camera cannot be correctly genlocked. In such a case, the internal time code is not correctly synchronized with the external time code.
- When the GENLOCK ON/OFF item is set to “OFF” on the GENLOCK page of the MAINTENANCE menu, the

time code cannot be synchronized with the reference video signal. In this case, set the GENLOCK item to “ON” on the GENLOCK page of the MAINTENANCE menu.

User bit settings during time code synchronization

When the time code is synchronized, only the time data is synchronized with the external time code value. Therefore, the user bits can have their own settings for each camcorder.

You can also synchronize the user bits with external user bit data.

For details, refer to the Maintenance Manual.

To release the time code synchronization

First disconnect the external time code, then set the F-RUN/SET/R-RUN switch to R-RUN.

To change the power supply from the battery pack to an external power supply during time code synchronization

To maintain a continuous power supply, connect the external power supply to the DC IN connector before removing the battery pack. You may lose time code synchronization if you remove the battery pack first.

Camera synchronization during time code synchronization

During time code synchronization, the camera is genlocked to the reference video signal input from the GENLOCK IN connector.

5-7 Setting the Thumbnail Image

When the unit is shipped from the factory, it is set up to display the first frame of a clip as the clip's thumbnail image (*see page 55*). As required, you can select another frame to display as a clip's thumbnail image. For example, if all clips have the same image in their first frames, you can specify a frame a few seconds after the start of the clip, so that all thumbnails will not show the same image.

To select the frame to display as a clip's thumbnail image

Proceed as follows.

- 1 Turn the POWER switch on.
- 2 Holding down the MENU knob, move the MENU ON/OFF switch to ON.

The TOP menu appears.

- 3 Turn the MENU knob to move the \blacktriangleright mark to "MAINTENANCE".

- 4 Press the MENU knob.

If this is the first time the MAINTENANCE menu has been displayed, the CONTENTS page of the MAINTENANCE menu appears. If the menu has been used before, the last accessed page appears.

- 5 If the CONTENTS page is displayed, turn the MENU knob to move the \blacktriangleright mark to "ESSENCE MARK", then press the MENU knob.

If a different page is displayed, turn the MENU knob until the ESSENCE MARK page appears, then press the MENU knob to select the page.

- 6 Press the MENU knob, then turn it to move the \blacktriangleright mark to "INDEX PIC.POS.", and press the MENU knob again.

The \blacktriangleright mark changes to a \bullet mark, and the \bullet mark changes to a ? mark.

?M10O	ESSENCE MARK	TOP
SHOT MARK 1	:	OFF
SHOT MARK 2	:	OFF
OVER AUDIO LIMIT	:	OFF
GAIN CHG. MARK	:	OFF
FILTER CHG. MARK	:	OFF
SHUTTER CHG. MARK	:	OFF
WHITE CHG. MARK	:	OFF
FLASH MARK	:	OFF
FLASH MARK LEVEL	:	10
\bullet INDEX PIC. POS.	:	? 0SEC

- 7 Turn the MENU knob to select the desired time.

- 8 Press the MENU knob.

The selection is confirmed.

- 9 Set the MENU ON/OFF switch to OFF to end the menu operation.

6-1 Overview

A remote computer can be connected to this unit and used to operate on recorded data which has been saved in data files, such as video and audio data files.

There are two way to connect a remote computer.

- FAM connection

Connect the **i**S400 (i.LINK) connector on this unit to the i.LINK (IEEE1394) connector on the remote computer, using an i.LINK cable (*see page 91*).

- FTP connection

Connect the network connectors on this unit and the remote computer, using a network cable (*see page 93*).

6-1-1 Directory Structure

The following figure shows the directory structure of discs visible to a remote computer.

Note

This structure is not the same as the actual structure recorded on the disc.

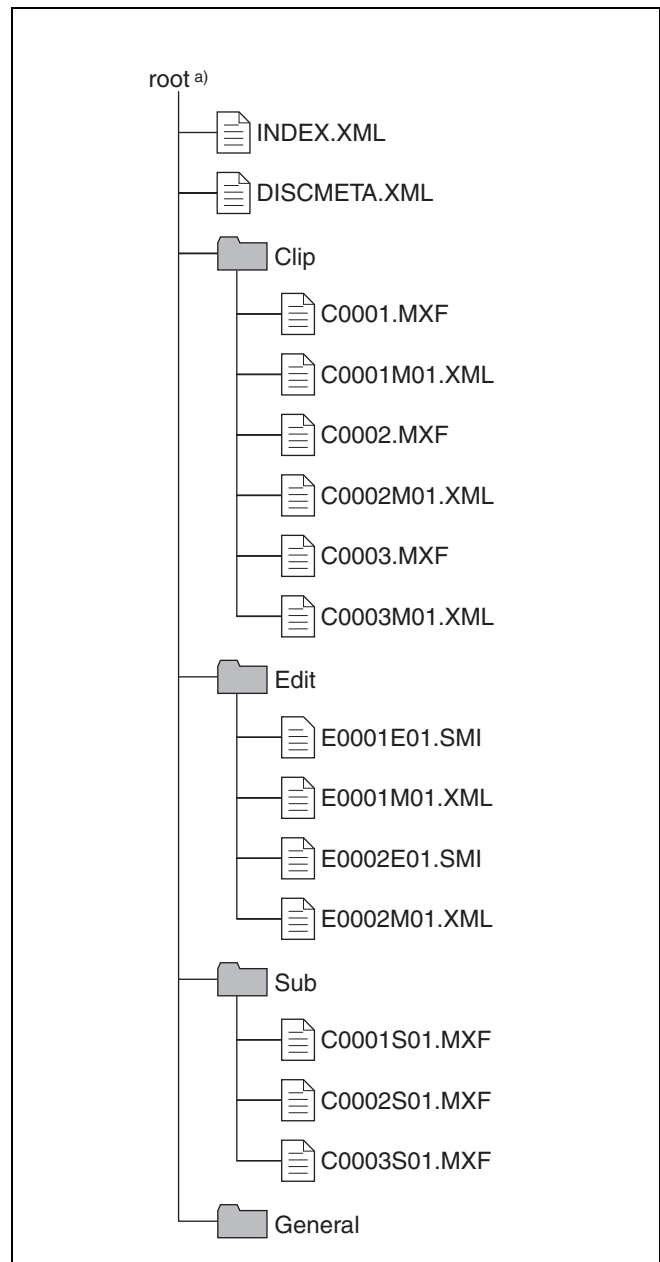

a) Root directory

6-1-2 File Operation Restrictions

This section explains which operations are possible on files stored in each directory.

When required, the following operation tables distinguish reading and writing from partial reading and writing.

Read: Read data sequentially from the start to the end of the file.

Partial read: Read only a part of the data in the file.

Write: Write data sequentially from the start to the end of the file.

Partial write: Write data to a part of the file only.

Root directory

File name	Content	Operations				
		Read/ Partial read	Write/ Partial write	Rename	Create	Delete
INDEX.XML	Contains information about all material on the disc.	Yes	No	No	No	No
DISCMETA.XML	Contains the disc ID and disc label.	Yes	Yes ^{a)}	No	No	No
Other files	Files other than the above	–	No	–	No	–

a) Only files which can be written by XDCAM

Notes

- Directories cannot be created in the root directory.
- The directories in the root directory (Clip, Edit, Sub, and General) cannot be deleted or renamed.

Clip Directory

File name	Content	Operations				
		Read/ Partial read	Write/ Partial write	Rename	Create	Delete
C*.MXF	Clip file created by recording (MXF file) *: 0001 to 0300	Yes	No	No	Yes ^{a)}	Yes ^{b)}
C*M01.XML	Metadata file generated automatically when C*.MXF file is created. *: 0001 to 0300	Yes	Yes ^{c)}	No	No ^{d)}	No ^{e)}
Other files	Files other than the above	–	No	–	No	–

a) Only files which are 2 seconds or longer in length, in a format matching the line mode format (525/625) and recording format (IMX50/IMX40/IMX30/DVCAM and number of audio channels) of the recorded sections of the disc, and which can be overwritten by XDCAM.

b) Only most recently recorded clip

c) Only files which can be written by XDCAM

d) When a C*.MXF file is created, a C*M01.XML file with the same number is generated automatically.

e) When a C*.MXF is deleted, the C*M01.XML file with the same number is also deleted automatically.

Note

Directories cannot be created in the Clip directory.

Edit Directory

File name	Content	Operations				
		Read/ Partial read	Write/ Partial write	Rename	Create	Delete
E*E01.SMI	Clip list file *: 0001 to 0099	Yes	Yes ^{a)}	No	Yes ^{b)}	Yes ^{c)}

File name	Content	Operations				
		Read/ Partial read	Write/ Partial write	Rename	Create	Delete
E*M01.XML	Metadata file generated automatically when E*E01.MXF file is created. *: 0001 to 0099	Yes	Yes ^{a)}	No	No ^{d)}	No ^{e)}
Other files	Files other than the above	–	No	–	No	–

- a) Only files which can be written by XDCAM. Partial writing is not possible.
b) Only files which can be written by XDCAM
c) Only when the write-protect tab on the disc is set to enable recording, and when expanded menu item 310 REC INHIBIT is set to "off".
d) When an E*E01.MXF file is created, an E*M01.XML file with the same number is generated automatically.

- e) When an E*E01.MXF is deleted, the E*M01.XML file with the same number is also deleted automatically.

Note

Directories cannot be created in the Edit directory.

Sub Directory

File name	Content	Operations				
		Read/ Partial read	Write/ Partial write	Rename	Create	Delete
C*S01.MXF	Proxy AV data (MXF) file generated automatically when a C*.MXF file is created. *: 0001 to 0300	Yes	No	No	No ^{a)}	No ^{b)}
Other files	Files other than the above	–	No	–	No	–

- a) When a C*.MXF file is created, a C*S01.MXF file with the same number is generated automatically.
b) When a C*.MXF is deleted, the C*S01.MXF file with the same number is also deleted automatically.

Note

Directories cannot be created in the Sub directory.

General Directory

File name	Content	Operations				
		Read/ Partial read	Write/ Partial write	Rename	Create	Delete
Any file		Yes	Yes	Yes ^{a)}	Yes	Yes ^{b)}

- a) File name up to 63 characters
b) Only when the write-protect tab on the disc is set to enable recording, and when expanded menu item 310 REC INHIBIT is set to "off".

The following directory operations are possible in the General directory.

- Directory creation (up to 64 levels, including the General directory)
- Deletion and renaming of directories

Note

- The maximum number of files that can be created on one disc, including directories, is 5000.
- The following characters can be used in file names and directory names
0 to 9 (digits), a to z (lowercase alphabetic), A to Z (uppercase alphabetic), @ (at mark), – (minus), _ (underscore), . (period), ~ (tilde), and (space).

6-2 File Access Mode File Operations

File access mode operating environment

Operating system requirements for file operations by file access mode (called FAM below) are as follows.

- Computer operating system: Microsoft Windows 2000 Service Pack 4 or higher, or Microsoft Windows XP

Preparations

Do the following on the remote computer and this unit.

- Install the FAM driver on the remote computer.
- Enable FAM connections over the i.LINK connector.

To install the FAM driver

Insert the supplied CD-ROM (Proxy Browsing Software PDZ-1) in the CD-ROM drive of the computer and execute the Setup.exe file, then follow the installation instructions.

For details, refer to the ReadMe file contained on the CD-ROM disc.

To enable FAM connections over the i.LINK connector

Proceed as follows.

- 1 Set the MENU ON/OFF switch to ON.
The last accessed page appears.
- 2 Turn the MENU knob to scroll to the OUTPUT page, then press the MENU knob.
The OUTPUT page appears. The current settings appear on the right side of each item.
- 3 Move the \blacktriangleright mark to "i.LINK MODE", then press the MENU knob.
The \blacktriangleright mark changes to a \bullet mark, and the \bullet mark changes to a ? mark.

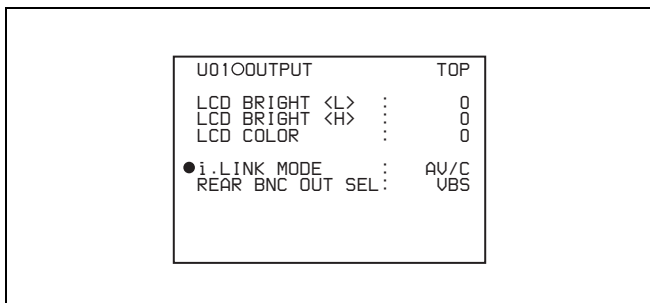

- 4 Turn the MENU knob to select FAM, then press the MENU knob.

The setting is confirmed. The \bullet mark changes to a \blacktriangleright mark and the ? mark changes to a \bullet mark.

- 5 Set the MENU ON/OFF switch to OFF to end the menu operation.

Making FAM connections

Proceed as follows.

- 1 If there is a disc loaded in this unit, put the unit into the following state.
 - Recording, playback, search and other disc operations: Stopped
 - Thumbnail indicator (see page 26): Off
 - Disc access by DELETE LAST CLIP, DELETE ALL CLIPS (see page 43), QUICK FORMAT (see page 39), and so on: Stopped
 - Picture Cache function and Interval Rec function: Off
 - MENU ON/OFF switch: OFF
 - F-RUN/SET/R-RUN switch: F-RUN or R-RUN
- 2 If this unit is connected to a remote computer by FTP, log out from the FTP session (see page 94).
- 3 Connect the i.LINK DV IN/OUT S400 connector on this unit to the i.LINK (IEEE1394) connector on the remote computer, using an i.LINK cable.

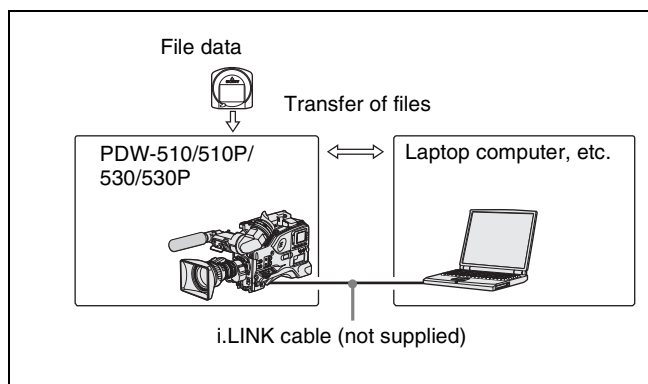

Windows recognizes this unit as a removable disc, and displays one of the following icons on the remote computer's task bar:

- Windows 2000:
- Windows XP:

The remote computer is now able to perform file operations when a disc is inserted into this unit.

Operation limitations during FAM connections

- With the exception of the EJECT button, recording buttons and playback control buttons are disabled.

- VDR of this unit cannot be controlled from devices connected to the REMOTE connector (8-pin) and i.S400 (i.LINK) connector.
- There is no signal output from this unit while video is being input to this unit from external equipment.

Operating on files

Proceed as follows.

1 Start Explorer.

Check that a drive letter has been assigned to this unit. (The drive letter will differ depending on the number of other peripherals connected to the remote computer.)

2 Use Explorer to perform file operations on the disc loaded in this unit.

You can operate in the same way that you operate on local drives and files on network computers.

Notes

- If you power this unit off during an FAM connection, the data transferred thus far is discarded.
- All file operations are not possible for some types of files.

For details, see 6-1-2 “File Operation Restrictions” (page 89).

To eject discs from a remote computer

Right click the icon representing this unit in Explorer, and select Eject from the menu which appears.

Exiting file operations

Proceed as follows.

Note

Do not disconnect the cable before performing steps 1 to 3.

1 Do one of the following on the or icon displayed in the remote computer’s taskbar.

- Double click.
- Right click, and select one of the following commands from the menu which appears.
 - **Windows 2000:** Unplug or eject hardware
 - **Windows XP:** Safely Remove Hardware
- **Windows 2000:** The Unplug or Eject Hardware dialog appears.
- **Windows XP:** The Safely Remove Hardware dialog appears.

2 Select “Sony XDCAM PDW-530 (or 530p/510/510P) IEEE 1394 SBP2 Device” and click Stop.

The Stop a Hardware device dialog appears.

3 Select “Sony XDCAM PDW-530 (or 530p/510/510P) IEEE 1394 SBP2 Device” and click OK.

- **Windows 2000:** A confirmation message appears.
- **Windows XP:** “Sony XDCAM PDW-530 (or 530p/510/510P) IEEE 1394 SBP2 Device” is deleted from the Hardware devices list.

This unit can now resume normal operations. (The limitations described in “Operation limitations during FAM connections” (*see page 91*) no longer apply.)

4 Disconnect the i.LINK cable as required.

Reconnecting

To reconnect after exiting file operations, do one of the following, depending on whether an i.LINK cable is connected.

i.LINK cable is not connected: Connect this unit and a remote computer with an i.LINK cable.

i.LINK cable is connected: Disconnect the i.LINK cable from either this unit or the remote computer, wait for at least 10 seconds, and then reconnect the disconnected cable.

The unit is powered off and an i.LINK cable is connected: Power the unit on.

To disable FAM connections

Execute one of the procedures described in the previous section “Reconnecting” to make a FAM connection between this unit and the remote computer. To disable FAM connections, set the menu item PC REMOTE to “DSABL.”

For more information about how to make this setting, see “To enable FAM connections over the i.LINK connector” (page 91).

6-3 FTP File Operations

File operations between this unit and a remote computer can be carried out by the File Transfer Protocol (called FTP below).

A CBK-NC01 Network Adaptor (option) is required to enable file operations by FTP.

For installation and use, see the *Installation Manual* supplied with the CBK-NC01.

Preparations

- 1 Connect the network connectors of this unit and a remote computer with a network cable. Or connect this unit to the network to which the remote computer is connected.

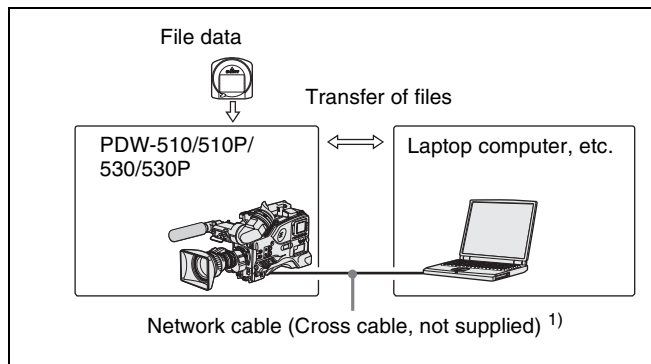

1) To make connections to the LAN through a hub, use straight type network cables (not supplied).

- 2 Set the IP address and other network setting items for this unit.

For details, see 7-3-11 "Making Network Settings" (page 128).

If network settings have already been made
Check the IP address of this unit.

- 3 Set the remote control switch to NETWORK.

Making FTP connections

FTP connections between this unit and a remote computer can be made with either of the following.

- The command prompt
- FTP client software

This section explains how to use the command prompt. For more information about using FTP client software, refer to the documentation of the FTP client software on your system.

To log in

If this unit is connected to a remote computer with a FAM connection, first exit file operations on the FAM connection (see page 92).

- 1 Load a disc into this unit and put the unit into the following state.
 - Recording, playback, search, and other disc operations: Stopped
 - Thumbnail indicator (see page 26): Off
 - Picture Cache function and Interval Rec function: Off
 - MENU ON/OFF switch: OFF
 - F-RUN/SET/R-RUN switch: F-RUN or R-RUN

Note

Login is not possible unless the unit is in the state described above.

- 2 Start the command prompt.
- 3 Enter "ftp <SP> <IP address>," and press the Enter key. (<SP> refers to a space.)

For example, if the IP address of this unit is set to 192.168.001.010, enter "ftp 192.168.1.10."

Refer to the Windows help for more information about the FTP command.

If the connection succeeds, you are prompted to enter a user name.

- 4 Enter the user name "admin" and press the Enter key.
When the user name is verified, you are prompted to enter a password.
- 5 Enter the password and press the Enter key.

The password is set to "pdw-530 (or 510)" when the unit is shipped from the factory.
The login is complete when the password is verified.

See 6-3-1 "Command List" (page 95) for the FTP commands supported by this unit.

If the connection times out

This unit terminates FTP connections if no command is received within 90 seconds of the last command. If this occurs, log out (see the next section) and repeat steps 2 to 4.

Note

If you power this unit off during an FTP connection, the data transferred thus far is discarded.

To log out

To log out after finishing file operations, enter “QUIT” at the command prompt and press the Enter key.



6-3-1 Command List

This unit supports standard FTP commands (*see the next section*), and extended FTP commands (*see page 99*).

Standard commands

The following table shows the standard FTP commands supported by this unit.

In the command syntax column, <SP> means a space, entered by pressing the space bar, and <CRLF> means a new line, entered by pressing the Enter key.

Command name	Description	Command syntax
USER	Send this command to begin the login process.	USER <SP> <username> <CRLF> Input example: USER admin
PASS	After sending the USER command, send this command to complete the login process.	PASS <SP> <password> <CRLF> Input example: PASS pdw-530 (or 510)
QUIT	Terminates the FTP connection. If a file is being transferred, terminates after completion of the transfer.	QUIT <CRLF>
PORT	Specifies the IP address and port to which this unit should connect for the next file transfer (for data transfer from this unit).	PORT <SP> <h1,h2,h3,h4,p1,p2> <CRLF> <ul style="list-style-type: none"> • h1 (most significant byte) to h4 (least significant byte): IP address • p1 (most significant byte), p2 (least significant byte): Port address Input example: PORT 10,0,0,1,242,48 (IP address: 10.0.0.1, Port number: 62000)
PASV	This command requests this unit to “listen” on a data port (which is not its default data port). It puts this unit into passive mode, waiting for the remote computer to make a data connection.	PASV <CRLF>
TYPE	Specifies the type of data to be transferred.	TYPE <SP> <type-code (options delimited by <SP>)> <CRLF> <type-code> can be any of the following. However, for XDCAM, data is always transferred as “I,” regardless of the type-code specification. <ul style="list-style-type: none"> • A: ASCII <ul style="list-style-type: none"> - N: Non-print (default) - T: Telnet format - C: ASA Carriage Control • E: EBCDIC <ul style="list-style-type: none"> - N: Non-print - T: Telnet format - C: ASA Carriage Control • I: IMAGE (Binary) • L: LOCAL BYTE <ul style="list-style-type: none"> - SIZE: byte size Input example: TYPE I

Command name	Description	Command syntax
STRU	Specifies the data structure.	<p>STRU <SP> <structure-code> <CRLF></p> <p><structure-code> can be any of the following. However, for XDCAM, the structure is always "F," regardless of the structure-code specification.</p> <ul style="list-style-type: none"> • F: File structure (default) • R: Record structure • P: Page structure <p>Input example: STRU F</p>
MODE	Specifies the transfer mode.	<p>MODE <SP> <mode-code> <CRLF></p> <p><mode-code> can be any of the following. However, for XDCAM, the mode is always "S," regardless of the mode-code specification.</p> <ul style="list-style-type: none"> • S: Stream mode (default) • B: Block mode • C: Compressed mode <p>Input example: MODE S</p>
LIST	Sends a list of files from this unit to the remote computer.	<p>LIST <SP> <options> <SP> <path-name> <CRLF></p> <p><options> can be any of the following.</p> <ul style="list-style-type: none"> • -a: Also display file names that begin with "." • -F: Append "/" to directory names. <p>The following data is transferred, depending on whether <path-name> specifies a directory or file.</p> <ul style="list-style-type: none"> • Directory specified: A list of the files in the specified directory • File specified: Information about the specified file • No specification: A list of the files in the current directory. <p>The wildcard characters "*" (any string) and "?" (any character) may be used in <path-name>.</p> <p>Input example 1: LIST -a Clip Input example 2: LIST Clip/*.MXF</p>
NLST	Sends a list of file names from this unit to the remote computer, with no other information.	<p>NLST <SP> <options or path-name> <CRLF></p> <p>The following options may be specified when no path name is specified.</p> <ul style="list-style-type: none"> • -a: Also display file names that begin with "." • -l: Display information other than file name (gives the same result as the LIST command). • -F: Append "/" to directory names. <p>The following data is transferred, depending on whether <path-name> specifies a directory or file.</p> <ul style="list-style-type: none"> • Directory specified: A list of the file names only in the specified directory • No specification: A list of the file names only in the current directory. <p>The wildcard characters "*" (any string) and "?" (any character) may be used in <path-name>.</p> <p>Input example 1: NLST l Input example 2: NLST Clip/*.MXF</p>
RETR	Begins transfer of a copy of a file in the specified path on this unit to the current directory on the remote computer.	<p>RETR <SP> <path-name> <CRLF></p> <p>Input example: RETR Clip/C0001.MXF</p>

Command name	Description	Command syntax
STOR	<p>Begins transfer of a copy of a file in the specified path on the remote computer to the current directory on this unit. Depending on the type of file transferred, the following items are created.</p> <ul style="list-style-type: none"> • C*.MXF file <ul style="list-style-type: none"> - C*M01.XML file (metadata) - C*S01.MXF file (proxy AV data) - UMID (The UMID of the copy source file is not saved. However, it is saved if an immediately preceding SITE UMMD extended command has been issued.) • E*E01.SMI file <ul style="list-style-type: none"> - E*M01.XML file (metadata) <p>*: 0001 to 0300</p> <p>Notes</p> <ul style="list-style-type: none"> • For C*.MXF files, some data, such as file header metadata, may be missing. • Depending on the transfer destination directory and the file type, transfer may not be possible. <p><i>For details, see 6-1-2 “File Operation Restrictions” (page 89).</i></p>	<p>STOR <SP> <path-name> <CRLF></p> <p>Input example: STOR Data/E0001E01.SMI</p>
RNFR RNTO	<p>Rename a file. Specify the file to be renamed with the RNFR command, and specify the new name with the RNTO command. (Always follow a RNFR command with a RNTO command.)</p> <p>Note</p> <p>Files in directories other than the General directory cannot be renamed.</p> <p><i>For details, see 6-1-2 “File Operation Restrictions” (page 89).</i></p>	<p>RNFR <SP> <path-name (before change)> <CRLF> RNTO <SP> <path-name (after change)> <CRLF></p> <p>Input example: RNFR General/info.txt RNTO General/clip_info.txt</p>
DELE	<p>Deletes the specified file on this unit.</p> <p>Note</p> <p>Depending on the directory and file type, deletion may not be possible.</p> <p><i>For details, see 6-1-2 “File Operation Restrictions” (page 89).</i></p>	<p>DELE <SP> <path-name> <CRLF></p> <p>Input example: DELE Clip/C0099.MXF</p>

Command name	Description	Command syntax
STAT	Sends information about properties of the specified file, or about data transfer status, from this unit to the remote computer. The following property information is sent, depending on the file type. <ul style="list-style-type: none"> • MXF file <ul style="list-style-type: none"> - File name - File type - CODEC type - Frame rate - Number of audio channels - Duration • non-MXF file <ul style="list-style-type: none"> - File name 	STAT <SP> <path-name> <CRLF> The following data is transferred, depending on whether a file is specified with <path-name>. <ul style="list-style-type: none"> • File specified: The properties of the specified file • No specification: The size of the data transferred thus far (unit: bytes) Input example: STAT Clip/C0001.MXF
ABOR	Requests this unit to abort a file transfer currently in progress.	ABOR <CRLF>
SYST	Displays the system name of this unit.	SYST <CRLF>
HELP	Displays a list of the commands supported by this unit, or an explanation of the specified command.	HELP <SP> <command-name> <CRLF> The following data is transferred, depending on whether a command name is specified with <command-name>. <ul style="list-style-type: none"> • Command name specified: Explanation of the specified command. • No specification: Command list Input example: HELP RETR
NOOP	Does nothing except return a response. (Used to check whether this unit is running.)	NOOP <CRLF>
PWD	Displays the current directory ("/" if the directory is the root directory).	PWD <CRLF>
CWD	Changes the current directory (moves from the current directory to another directory).	CWD <SP> <path-name> <CRLF> Moves to a directory as follows, depending on whether a directory is specified with <path-name>. <ul style="list-style-type: none"> • Directory specified: To the specified directory • No specification: To the root directory Input example: CWD General
CDUP	Moves one level up in the directory structure (makes the parent of the current directory be the current directory).	CDUP <CRLF>
MKD	Creates a new directory. Note Directories can be created only in the General directory. <i>For details, see 6-1-2 "File Operation Restrictions" (page 89).</i>	MKD <SP> <path-name> <CRLF>
RMD	Deletes a directory. Note Directories can be deleted only in the General directory. <i>For details, see 6-1-2 "File Operation Restrictions" (page 89).</i>	RMD <SP> <path-name> <CRLF>

Extended commands

The following table shows the extended FTP commands supported by this unit.

In the command syntax column, <SP> means a space, entered by pressing the space bar, and <CRLF> means a new line, entered by pressing the Enter key.

Command name	Description	Command syntax
SITE REPF	<p>Sends an MXF file from the specified path on this unit to the remote computer. This command allows you to specify a segment in the body of the MXF file (composed of video and audio data), for transfer of the required segment only.</p> <p>Note A segment greater than the file size cannot be specified.</p>	<p>SITE REPF <SP> <path-name> <SP> <start-frame> <SP> <transfer-size> <CRLF></p> <p><start-frame> specifies an offset from the start of the file. Data is transferred from the video frame at the offset (the first frame is 0). <transfer-size> specifies the number of video frames to transfer (specify 0 to transfer to the end of the file).</p> <p>Input example: SITE REPF Clip/C0001.MXF 5 150 (Transfer C0001.MXF. Body data is transferred only from frame 6 to frame 155.)</p>
SITE FSTS	<p>Acquires the system status of this unit. One of the following status codes is sent. 0: Initial state, or no disc is loaded. 1: File system mount is OK. 3: File system mount is not OK.</p>	SITE FSTS <CRLF>
SITE MEID	Acquires the media ID of the disc loaded in this unit.	SITE MEID <CRLF>
SITE FUNC	<p>Acquires the function and version of the expanded commands. Information is sent in the following format. <main function> <SP> <branch function> <SP> <branch function version> For XDCAM, sent in a format like "200 MXF DISK 1" (200 is a response code).</p>	SITE FUNC <CRLF>
SITE UMMD	When C*.MXF file (*: 0001 to 0300) is sent with the STOR, the copy source UMID is saved if this command is invoked immediately before the STOR command.	SITE UMMD <CRLF>

Menu Displays and Detailed Settings

Chapter

7

7-1 Menu Organization and Operation

7-1-1 Menu Organization

The following shows the organization of menus that you can use to make various settings and adjustments.

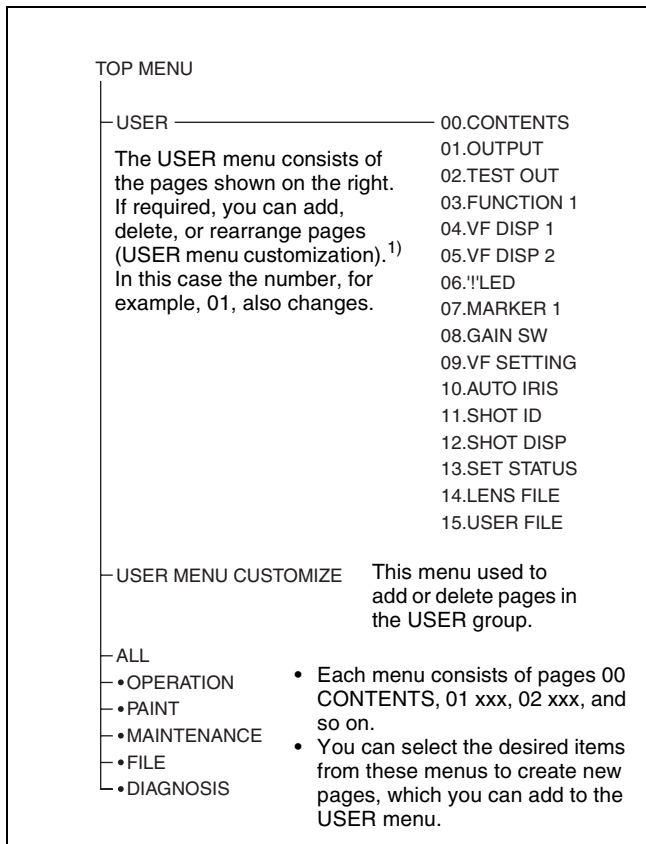

1) In this manual, the USER menu consisting of items and pages registered at the factory is used.

For details of customizing the USER menu, see 7-1-4 “Editing the USER Menu” on page 103.

TOP menu

The TOP menu consists of the following submenus.

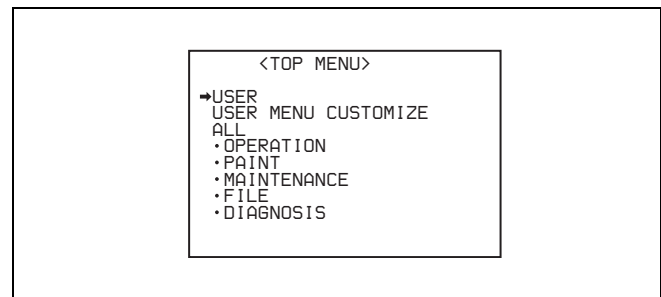

When you select an item in the TOP menu, this displays the most recently shown page of the corresponding submenu. When the submenu is selected for the first time, the 00 CONTENTS page appears.

Submenus selected in the TOP menu

These are the following menus.

• USER menu:

This menu includes monitor output settings, viewfinder settings, and commonly used functions. This menu is normally displayed when the MENU ON/OFF switch is changed to ON.

• USER MENU CUSTOMIZE menu:

This menu allows you to add pages to or delete pages from the USER menu to suit your needs.

• ALL menu:

This menu contains all items of the OPERATION menu, PAINT menu, MAINTENANCE menu, FILE menu and DIAGNOSIS menu.

• **OPERATION menu:**

This menu contains items for changing settings according to conditions related to the subject when the camcorder is being operated.

• **PAINT menu**

This menu contains items for making detailed image adjustments while using a waveform monitor to monitor the waveforms output by the camera. Support of a video engineer is usually required to use this menu. Although you can also use an external remote control panel or master setup unit to set the items on this menu, this menu is effective when using the camcorder by itself outdoors.

• **MAINTENANCE menu**

This menu contains items for performing camera maintenance operations, such as changing the VDR system or using infrequently used “paint” items.

• **FILE menu**

This menu is for performing file operations, such as writing the reference file.

• **DIAGNOSIS menu**

This menu enables you to confirm the VDR status or identify a failed circuit board.

7-1-2 Displaying Menus

The camcorder can display menus both on the viewfinder screen and on the color LCD.

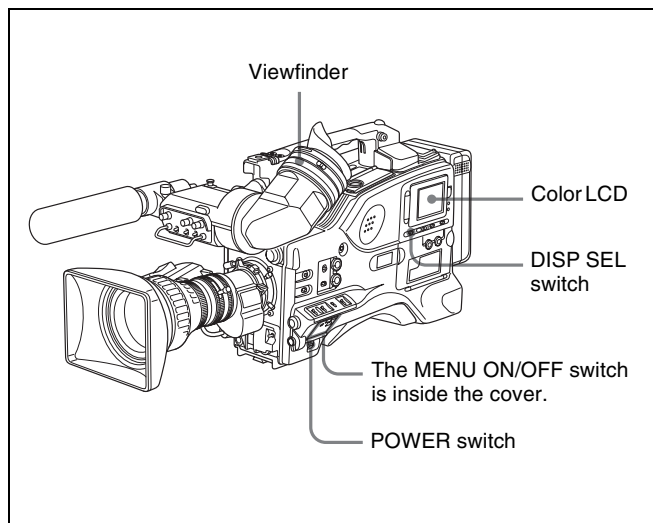

Displaying menus on the viewfinder screen

When the camcorder is powered on, open the cover of the menu operating section, and set the MENU ON/OFF switch to the ON position.

This displays menus on the viewfinder screen, regardless of the ON/OFF setting of the viewfinder DISPLAY switch.

Displaying menus on the color LCD

With the camcorder powered on, proceed as follows.

- 1 Open the cover of the menu operating section, and set the MENU ON/OFF switch to the ON position.
- 2 Set the DISP SEL switch at the lower left of the color LCD to CHAR.

This displays menus on the color LCD.

In the remainder of this section, the viewfinder display is generally shown as an example menu display, but the display on the color LCD is similar.

7-1-3 Basic Menu Operations

When you open the cover of the menu operating section, the MENU ON/OFF switch appears. If the MENU ON/OFF switch is set to ON, the USER menu is displayed on the screen. Closing the cover automatically sets the MENU ON/OFF switch to OFF.

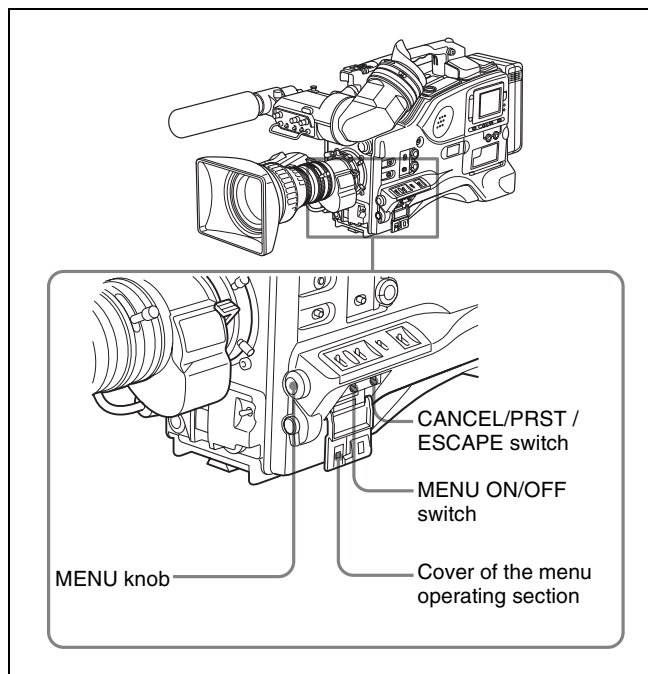

Controls used for the basic use of the menu operations

Displaying the TOP menu

Hold down the MENU button, and move the MENU ON/OFF switch from the OFF to the ON position.

Note

Depending on the internal switch settings, display of the TOP menu may be disabled.

For details, refer to the Maintenance Manual.

Returning to the TOP menu from other menus

There are two methods.

- Align the **▶** mark with “TOP” at the top right of the menu page, and press the MENU knob.
- Push the CANCEL/PRST / ESCAPE switch down to the ESCAPE position repeatedly until the TOP menu appears.

Menu operations in the USER menu

This section explains operations on the USER menu. But the operations are the same as those on menus other than the USER menu. Also, if the optional extension boards are not installed in your camcorder, some items on the USER menu pages are not displayed. But the operations are the same as those on the menus other than the USER menu. To carry out menu operations in the USER menu, proceed as follows.

- 1 Switch the MENU ON/OFF switch from OFF to ON.

The USER menu normally appears. If it does not, in the TOP menu select USER, and press the MENU knob.

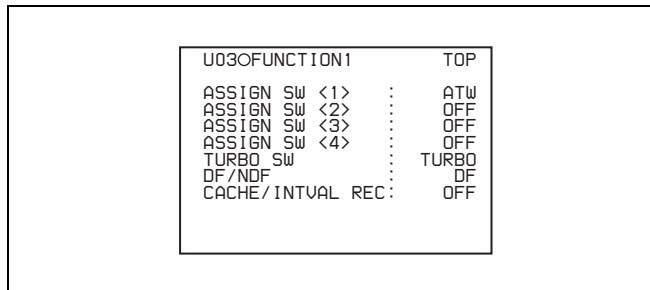

(For the PDW-530P/510P, the DF/NDF item is not included.)

If the USER menu has been used before, the last accessed page appears. In this case, go to step 2. If this is the first time the USER menu has been displayed, the CONTENTS page of the USER menu appears. In this case, follow the procedure below.

- ① Turn the MENU knob to move the **▶** mark to the desired page number.

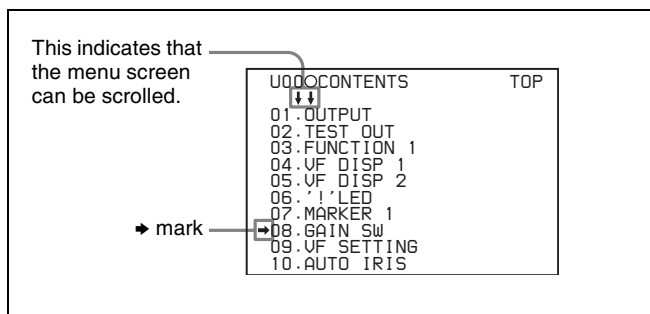

- ② Press the MENU knob.
The selected page is displayed. Go to step 4.

- 2 Turn the MENU knob until the desired page appears.

- 3 Press the MENU knob.

A **▶** mark appears on the left of the item currently selected on the page.

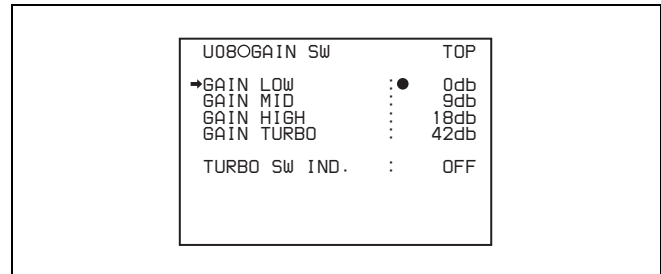

- 4 Turn the move MENU knob to move the **▶** mark to the desired item.

- Turning the MENU knob counterclockwise as seen from the front of the camera moves the **▶** mark up continuously.
- Turning the MENU knob clockwise as seen from the front of the camera moves the **▶** mark down continuously.

- 5 Press the MENU knob.

The **▶** mark on the left of the selected item changes to a **●** mark and the **●** mark on the left of the setting changes to a **?** mark.

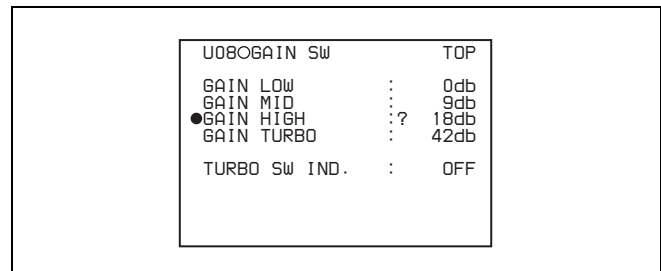

- 6 Turn the MENU knob to change the setting.

Before going to the next step, you can cancel a change or return to the standard settings. For this operation, see the next item “*To cancel a change or return to the standard settings*” on page 103.

To interrupt changing the settings

By setting the MENU ON/OFF switch to OFF, the menu disappears from the screen. By setting the MENU ON/OFF switch to ON again, the values that were displayed when you interrupted the setting operations will reappear so you can continue making settings.

- 7 Press the MENU knob.

The **●** mark changes to a **▶** mark and the **?** mark changes to a **●** mark. The setting is confirmed.

- To continue setting other items in the same page, repeat steps from 4 to 7.

To cancel a change or return to the standard settings

Proceed as follows.

- Before pressing the MENU button in step 7 of the above procedure, push the CANCEL/PRST / ESCAPE switch up to the CANCEL/PRST position.

Under the page name, a message “CANCEL DATA OK?” appears.

- Push the CANCEL/PRST / ESCAPE switch up to the CANCEL/PRST position once more.

A message “CANCEL DATA” appears to indicate that the change has been cancelled.

- To return to the standard settings, push the CANCEL/PRST / ESCAPE switch up to the CANCEL/PRST position.

A message “PRESET DATA OK?” appears on the screen.

- Push the CANCEL/PRST / ESCAPE switch up to the CANCEL/PRST position once more.

This returns to the standard settings.

Depending on the setting item, in some cases only the function to return to the standard setting is valid. Check this for each individual item.

To move to another page

Proceed as follows.

- Turn the MENU knob to move the ➔ arrow to the page number, then press the MENU knob.

If the ➔ mark is placed at a position other than the page number, push the CANCEL/PRST / ESCAPE switch to ESCAPE.

A ? mark appears in front of the page number. The camcorder is now in page selecting mode.

- Turn the MENU knob until the desired page appears.
- Press the MENU knob when the desired page appears.

To end menu operations

You can end menu operations using the following two methods:

- Turn the MENU ON/OFF switch to OFF.

- Close the cover of the menu operating section. When you close the cover, the MENU ON/OFF switch is set to OFF automatically.

The menu disappears from the screen, and the display indicating the current status of the camcorder appears along the top and bottom of the screen (when the viewfinder DISPLAY switch is set to ON or the VF DISP item on the VF DISP 1 page of the USER menu is set to “ON”).

For details of the viewfinder display, see 7-2-2 “Selecting the Display Items” on page 109.

7-1-4 Editing the USER Menu

The USER MENU CUSTOMIZE menu allows you to configure a USER menu that consists only of pages and items that you need by adding, deleting or replacing the pages.

Adding a new page

The USER MENU CUSTOMIZE menu allows you to add a new page to the USER menu.

While the EDIT page contains factory-preset items, the USER 1 EDIT to USER 19 EDIT pages and the ASSIGN SEL EDIT page are all blank in their initial state. You can register up to 10 items, including blank lines, on each of these pages.

To add a new page, proceed as follows.

- While holding down the MENU knob, move the MENU ON/OFF switch from the OFF position to the ON position.

The TOP menu appears.

- Turn the MENU knob to move the ➔ mark to “USER MENU CUSTOMIZE”, then press the MENU knob.

If this is the first time the USER MENU CUSTOMIZE menu has been displayed, the CONTENTS page of the menu appears.

U000CONTENTS		TOP
01.	EDIT PAGE	
02.	USER 1	EDIT
03.	USER 2	EDIT
04.	USER 3	EDIT
05.	USER 4	EDIT
06.	USER 5	EDIT
07.	USER 6	EDIT
08.	USER 7	EDIT
09.	USER 8	EDIT
10.	USER 9	EDIT

If the USER MENU CUSTOMIZE menu has been used before, the last accessed page appears.

- If the CONTENTS page is displayed, turn the MENU knob to move the ➔ mark to one of USER 1 EDIT to

USER 19 EDIT and ASSIGN SEL EDIT, then press the MENU knob to display the page.

If a different page is displayed, turn the MENU knob until the desired page appears, then press the MENU knob to select the page.

Example: When you select the USER 2 EDIT page

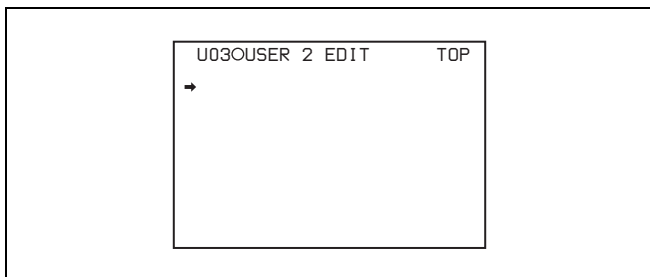

- 4 Move the ➔ mark to the item to be added (this operation is unnecessary, if no item exists on the page as shown in the figure for step 3), then press the MENU knob.

The EDIT FUNCTION page appears.

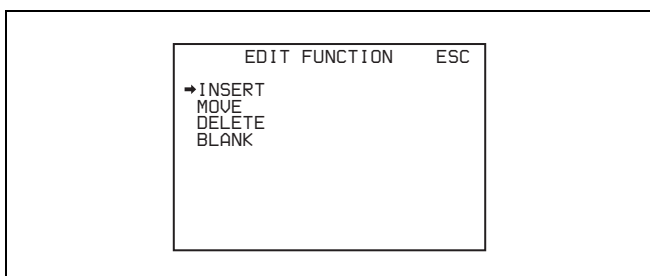

- 5 Move the ➔ mark to "INSERT", and press the MENU knob.

The page for the last added item appears.

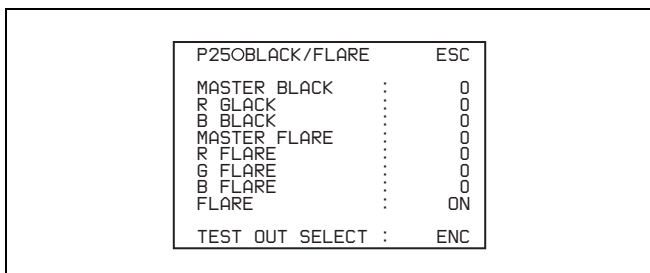

- 6 Add the items.
 - ① Turn the MENU knob until the page that has the desired items appears, then press the MENU knob.
 - ② Turn the MENU knob to move the ➔ mark to the desired item, then press the MENU knob.

The USER P2 EDIT page appears again, displaying the newly added item.

- 7 Add the remaining items by repeating steps 4 to 6.

You can add up to 10 items on one page.

Deleting items from a page by using the CANCEL/PRST / ESCAPE switch

You can delete items from any of the USER 1 EDIT to USER 19 EDIT pages. Proceed as follows.

- 1 Turn the MENU knob to move the ➔ mark to the item to be deleted.
- 2 Push the CANCEL/PRST / ESCAPE switch to CANCEL/PRST.

The message "PRESET DATA OK?" appears.

- 3 Push the CANCEL/PRST / ESCAPE switch to CANCEL/PRST again.

The item is deleted.

Deleting items from a page by using the menu

Proceed as follows.

- 1 Move the ➔ mark to the item to be deleted, and press the MENU knob.

The EDIT FUNCTION page appears.

- 2 Select "DELETE", and press the MENU knob.

The previously displayed page appears again, and the message "DELETE OK? Yes ➔ No" appears at the upper right.

- 3 To delete, turn the MENU knob to move the ➔ mark to "YES", and press the MENU knob.

Replacing items on a page

You can replace the items on any of the USER 1 EDIT to USER 5 EDIT pages. Proceed as follows.

- 1 Turn the MENU knob to move the ➔ mark to the item to be replaced, then press the MENU knob.

The EDIT FUNCTION page appears.

- 2 Select MOVE, then press the MENU knob.

The previously displayed page appears again.

- 3 Turn the MENU knob to move the ➔ mark to the position where you want to move the item, then press the MENU knob.

```

E020USER 1 EDIT      TOP
→WHITE<B>CH       :  AWB
TEST OUT MENU       :  OFF
OFFSET WHITE <A>    :  OFF
WARM COOL <A>      : 3200
COLOR FINE <A>     :    0
●MASTER BLACK      :    0

```

The item selected in step 1 moves to the position that you selected in step 3. In the above example, “MASTER BLACK” is moved to the top and the other items are moved down one line.

Inserting a blank line

You can insert a blank line above the selected item. Proceed as follows.

- 1 Turn the MENU knob to move the ➔ mark to the item above which you want to insert a blank line.

The EDIT FUNCTION page appears.

- 2 Select “BLANK”, and press the MENU knob.

The previously displayed page appears again, and a blank line is inserted above the specified item.

Note

You cannot insert a blank line on a page where 10 items have already been registered.

Adding/deleting/replacing pages

You can add a new page to the USER menu, delete a page from the USER menu or replace pages, using the EDIT PAGE of the USER MENU CUSTOMIZE menu.

To add a page

Proceed as follows.

- 1 While holding down the MENU knob, move the MENU ON/OFF switch from the OFF position to the ON position.

The TOP menu appears.

- 2 Turn the MENU knob to move the ➔ mark to “USER MENU CUSTOMIZE”, then press the MENU knob.

If this is the first time the USER MENU CUSTOMIZE menu has been displayed, the CONTENTS page of the menu appears. If the menu has been used before, the last accessed page appears.

- 3 If the CONTENTS page is displayed, turn the MENU knob to move the ➔ mark to “EDIT PAGE”, then press the MENU knob to display the EDIT PAGE screen.

If a different page is displayed, turn the MENU knob until the EDIT PAGE screen appears, then press the MENU knob to select the page.

```

E010EDIT PAGE      TOP
↓
01.OUTPUT
→02.TEST OUT
03.FUNCTION 1
04.VF DISP 1
05.VF DISP 2
06.'1'LED
07.MARKER 1
08.GAIN SW
09.VF SETTING
10.AUTO IRIS

```

- 4 Turn the MENU knob to move the ➔ mark to where you want to add the page, then press the MENU knob.

The EDIT FUNCTION page appears.

```

EDIT FUNCTION      ESC
→INSERT
MOVE
DELETE
BLANK

```

- 5 Select INSERT, and press the MENU knob.

The selection screen appears.

```

CONTENTS          ESC
→01.USER PAGE 1
02.USER PAGE 2
03.USER PAGE 3
04.USER PAGE 4
05.USER PAGE 5
06.USER PAGE 6
07.USER PAGE 7
08.USER PAGE 8
09.USER PAGE 9

```

- 6 Turn the MENU knob to move the ➔ mark to the desired page, then press the MENU knob.

This adds the number and name of the selected page above the item selected in step 4.

To cancel adding a page

Before pressing the MENU knob in step 6, turn the MENU knob to move the ➔ mark to “ESC” at the top right of the screen, then press the MENU knob. The EDIT PAGE screen appears again.

To delete a page by using the CANCEL/PRST / ESCAPE switch

Proceed as follows.

- 1 Open the EDIT PAGE and turn the MENU knob to move the ➔ mark to the page to be deleted.

- 2 Push the CANCEL/PRST / ESCAPE switch to CANCEL/PRST.

The message “PRESET DATA OK?” appears.

```
E01OEDIT PAGE
      DELETE PAGE OK ?
01.OUTPUT
02.TEST OUT
03.FUNCTION 1
→04.VF DISP 1
05.VF DISP 2
06.'!'LED
07.MARKER 1
08.GAIN SW
09.VF SETTING
10.AUTO IRIS
```

- 3 Push the CANCEL/PRST / ESCAPE switch to CANCEL/PRST again.

In the above example, the VF DISP 2 page is deleted.

To delete a page by using the menu

Proceed as follows.

- 1 On the EDIT PAGE screen of the USER MENU CUSTOMIZE menu, move the ► mark to the page to be deleted, and press the MENU knob.

The EDIT FUNCTION page appears.

- 2 Select DELETE, and press the MENU knob.

The previously displayed page appears again, and the message “DELETE PAGE OK?” appears at the upper right.

- 3 To delete, turn the menu knob to move the ► mark to “YES”, and press the MENU knob.

To move a page

Proceed as follows.

- 1 Display the EDIT PAGE screen of the USER MENU CUSTOMIZE menu. Turn the MENU knob to move the ► mark to the page that you want to move.

The EDIT FUNCTION page appears.

- 2 Select MOVE, then press the MENU knob.

The EDIT PAGE screen appears again.

- 3 Turn MENU knob to move the ► mark to the position to where you want to move the page selected in step 1.

```
E01OEDIT PAGE
      PUSH TO PAGE INSERT
01.OUTPUT
02.TEST OUT
03.FUNCTION 1
→04.VF DISP 1
05.'!'LED
06.MARKER 1
07.GAIN SW
08.VF SETTING
●09.AUTO IRIS
```

- 4 Press the MENU knob.

The page selected in step 1 is moved to the position selected in step 3.

In the above example, “AUTO IRIS” moves to the “04” position and the “VF DISP 1” and following items move down one line.

7-2 Status Display on the Viewfinder Screen

The viewfinder screen displays not only the video picture but also characters and messages indicating the camcorder settings and operating status, a center marker, a safety zone marker, etc.

When the MENU ON/OFF switch is set to OFF and the DISPLAY switch is set to ON, the items for which an “ON” setting was made in the VF DISP1 page of the USER menu or with related switches are displayed at the top and bottom of the screen. The messages that give details of the settings and adjustment progress and results can also be made to appear for about 3 seconds while settings are being changed, during adjustment, and after adjustment.

For information about the display item selection, see 7-2-2 “Selecting the Display Items” on page 109. For information about setting change and adjustment progress messages, see 7-2-3 “Display Modes and Setting Change Confirmation/Adjustment Progress Messages” on page 110. For information about marker display, see 7-2-4 “Setting the Marker Display” on page 111.

7-2-1 Layout of the Status Display on the Viewfinder Screen

All items that can be displayed on the viewfinder screen are shown below.

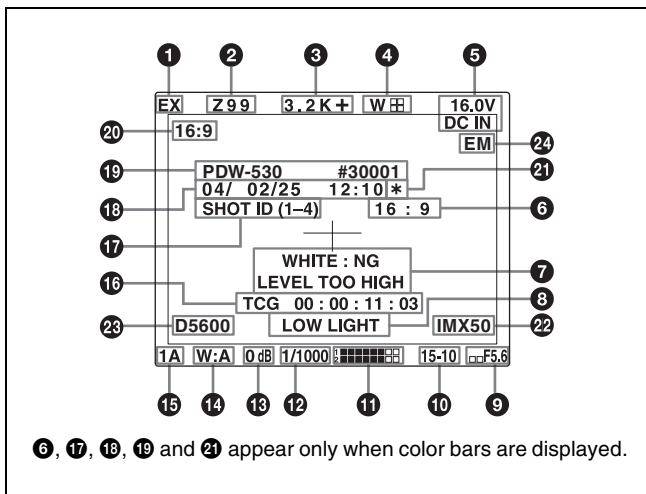

Status display on the viewfinder

1 Extender

“EX” is displayed when a lens extender is used.

2 Zoom position

This indicator appears only when you use a lens that has a zoom position display function. It indicates the approximate position of the variator ¹⁾ of the zoom lens, between wide angle and telephoto.

1) Variator

A group of lenses that are moved to adjust the focal length.

3 Color temperature

This indicates the currently selected color temperature.

4 UHF wireless microphone reception level

This indicates reception level of the wireless microphone when the UHF wireless microphone is attached, using four ■ which appear at the right of “W”. When four ■ are lit, the receiving condition is good.

5 DC IN / battery voltage or remaining capacity

This shows the battery voltage or remaining capacity of an internal battery pack.

When the power is supplied from an AC adaptor connected to the DC IN connector, “DC IN” appears.

When the DISP BATT REMAIN item is set to “INT” on the VF DISP 2 page of the USER menu, the battery voltage is not indicated. However, when the Anton Bauer intelligent battery system or the BP-IL75/GL95/M100 battery pack is used, the remaining battery capacity is automatically detected and indicated as a percentage even when the DISP BATT REMAIN item is set to “OFF”. The indicated value changes in steps of 10 %.

- Until the remaining battery capacity is reduced to 40 %, the indications MAX, 90 %, 80 %...40 % are displayed for three seconds in the viewfinder each time the remaining battery capacity reduces by 10 %.
- When the remaining battery capacity is less than 40 %, the indication is displayed all the time.
- When the remaining battery capacity is less than 10 % ¹⁾, the the indication flashes. When the remaining battery capacity is reduced further, the LOW indication flashes.

1) This value can be set to either 10 % or 20 % on the FUNCTION 2 page of the OPERATION menu.

6 16:9 mode recording indicator

This indicates recording in the 16:9 mode. This indicator is recorded together with the color bars.

7 Setting change and adjustment progress message display area

For details, see 7-2-3 “Display Modes and Setting Change Confirmation/Adjustment Progress Messages” on page 110.

8 Operation/error message display area

For details, see “Operation/error messages” on page 163.

9 Iris setting/auto iris override

This indicates the f-stop (iris setting) of the lens. Also, the auto iris override is displayed using bars which appear in the upper and lower parts to the left of the F number respectively.

For details, see “Changing the reference value” on page 79.

10 Remaining disc capacity

This indicator indicates the remaining disc recording time (in minutes) of the VDR.

Examples of remaining disc recording time indication

Indication	Remaining disc recording time
F - 30	Full to 30 minutes
30 - 25	30 to 25 minutes
25 - 20	25 to 20 minutes
20 - 15	20 to 15 minutes
15 - 10	15 to 10 minutes
10 - 5	10 to 5 minutes
5 MIN	5 to 4 minutes
4 MIN	4 to 3 minutes
3 MIN	3 to 2 minutes
2 MIN	2 to 1 minutes
1 (flashing)	1 to 0 minute
0 MIN (flashing)	0 minute

11 Audio level

These indicate the level of audio channel 1 and channel 2. The peak indication of the VDR level meter is related as follows to the audio level when an 1-kHz sine wave is input.

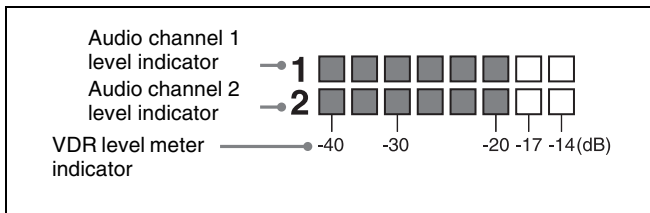

12 Shutter speed

This indicates the shutter speed or the shutter mode. However, if the SHUTTER selector is set to OFF, nothing is displayed.

1/100 (PDW-510/530) or 1/60 (PDW-510P/530P), 1/125, 1/250, 1/500, 1/1000, 1/2000: Shutter speed (in seconds) in standard mode (scan mode:I)

1/40, 1/100 (PDW-510/530) or 1/33, 1/50, 1/100 (PDW-510P/530P), 1/125, 1/250, 1/500, 1/1000, 1/2000: Shutter speed (in seconds) in standard mode (scan mode:PsF)

ECS: ECS mode

EVS: EVS mode

1F to 8F, 16F: Number of frames in SLS mode

13 Gain

This indicates the gain of the video amplifier, as set by the GAIN selector.

14 White balance memory

This indicates the currently selected white balance automatic adjustment memory.

A: Displayed when the WHITE BAL switch is set to A.

B: Displayed when the WHITE BAL switch is set to B.

P: Displayed when the WHITE BAL switch is set to PRST or when the preset button on the RM-B150 has been pushed.

T: Displayed when ATW is being used.

15 Filter

This indicates the currently selected filter types.

16 Time code

This indicates the time code, user bits or other information selected by the DISPLAY switch.

17 ID number

This indicates the ID number selected from ID 1 to ID 4. The ID number is recorded together with the color bars.

18 Date and time

This indicates the date and time of recording, which are recorded together with the color bars.

19 Model name and serial number

This indicates the model name and serial number of the camcorder, which are recorded together with the color bars.

20 16:9/4:3 mode

“16:9” or “4:3” is displayed depending on the currently selected aspect ratio.

21 *

This flashes when the color bars are displayed and is recorded together with the color bars

22 Recording format

This indicates the current recording format.

23 D5600 indication

This appears when the electric 5600 K color temperature filter function is on.

24 EM indicator

This appears when essence marks are recorded on the disc.

For details, see 3-2-3 “Recording Essence Marks” (page 43).

7-2-2 Selecting the Display Items

To select the items to be displayed on the viewfinder screen from the VF DISP 1 and VF DISP 2 pages of the USER menu, turn on or off the indication next to each item.

To select the items to be displayed on the viewfinder screen, proceed as follows.

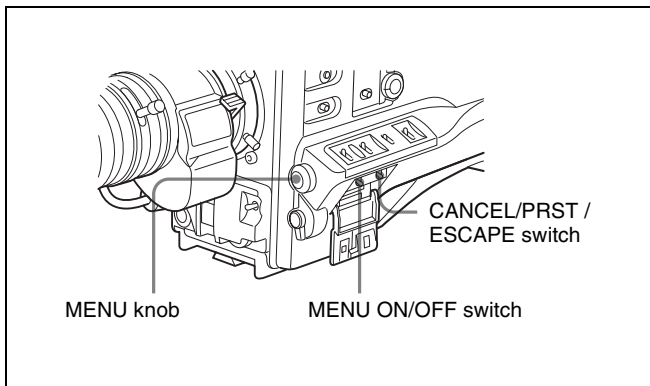

- 1 Set the MENU ON/OFF switch to ON.

The last accessed menu page appears on the viewfinder screen.

- 2 Turn the MENU knob until the VF DISP 1 or VF DISP 2 page appears, and press the MENU knob to select the page.

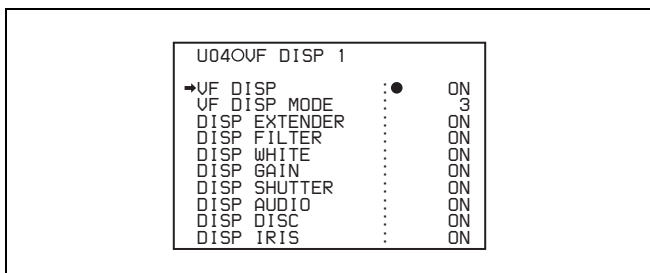

VF DISP 1 page

You can select the following items to be displayed on the screen on the VF DISP 1 or VF DISP 2 page.

VF DISP 1 page

Item	Description
VF DISP	Turning on or off the viewfinder display ¹⁾
VF DISPLAY MODE	Selecting the display mode ²⁾
DISP EXTENDER	Extender indicator
DISP FILTER	Types of the ND filter
DISP WHITE	White balance memory indicator
DISP GAIN	Gain indicator

Item	Description
DISP SHUTTER	Shutter speed and ECS mode indicator
DISP AUDIO	Audio level indicator
DISP DISC	Remaining disc capacity indicator
DISP IRIS	Iris opening indicator

- 1) The viewfinder display can be also turned on or off by using the DISPLAY switch on the viewfinder.
- 2) For detailed information on the display mode, see 7-2-3 "Display Modes and Setting Change Confirmation/Adjustment Progress Messages" on page 110.

VF DISP 2 page

Item	Description
DISP ZOOM	Zoom position indicator
DISP COLOR TEMP.	Displays the color temperature.
DISP BATT REMAIN ¹⁾	Displays the battery voltage/remaining capacity of an internal battery pack or an external battery connected to the DC IN connector.
DISP DC IN	Displayed when the power is supplied from an external battery connected to the DC IN connector.
DISP 16:9/4:3 ID	Displays the 16:9/4:3 mode indicator.
DISP WRR RF LVL	Displays the reception level of the wireless microphone.
DISP TIME CODE	Displays the time code.
DISP REC FORMAT	Displays the recording format.

- 1) When an Anton Bauer Intelligent Battery System or the BP-IL75/GL95/M100 battery pack is used, the setting of this item determines the display as follows.

INT: The remaining battery capacity is shown as a percentage when there is a change, and when the capacity is low.

AUTO: The remaining battery capacity is shown as a percentage, except that when this is impossible the battery voltage appears.

VOLT: The battery voltage is shown.

- 3 Turn the MENU knob to move the ➔ mark to the item you want to set, and press the MENU knob.

The ➔ mark on the left of the selected item changes to a ● mark and the ● mark on the left of the setting changes to a ? mark.

- 4 Turn the MENU knob to select whether the selected item should appear in the viewfinder display (the "ON" setting), or not appear (the "OFF" setting), and press the MENU knob.

The ● mark changes to a ➔ mark and the ? mark changes to a ● mark.

Note that pressing the CANCEL/PRST / ESCAPE switch to CANCEL/PRST on this page has no effect.

- 5 To set another item to “ON” or “OFF”, repeat steps 3 and 4.
- 6 To end the menu operation, set the MENU ON/OFF switch to OFF or close the cover of the menu operating section.

7-2-3 Display Modes and Setting Change Confirmation/ Adjustment Progress Messages

You can limit or suppress the messages that give details of setting changes and adjustment progress and results by setting a display mode.

The conditions under which messages are displayed and their correspondence with the display mode are as follows:

Setting change confirmation/adjustment progress messages and display modes

Y: Message is displayed.

N: Message is not displayed.

Message display condition	Message	Display mode setting		
		1	2	3
When the filter selection has been changed	ND : n, CC : m (where n = 1, 2, 3, 4, m = A, B, C, D)	N	N	Y
When the gain setting has been changed	GAIN : n (where n = -3dB, 0dB, 3dB, 6dB, 9dB, 12dB, 18dB, 24dB, 30dB, 36dB, 42dB, 48dB)	N	N	Y
When the setting of the WHITE BAL switch has been changed	WHITE : n (where n = A CH, B CH, PRESET) or ATW : RUN	N	N	Y
When the OUTPUT/DCC selector has been set to DCC ON or OFF	DCC : ON (or OFF)	N	Y	Y
When the shutter speed and mode setting has been changed ¹⁾	SS : 1/100 (PDW-510/530) or 1/60 (PDW-510P/530P) (or 1/125, 1/250, 1/500, 1/1000, 1/2000, ECS, SLS)	N	Y	Y
When the black or white balance has been adjusted	E.g. WHITE : OK	N	Y	Y

1) This is also displayed for about 3 seconds when the SHUTTER selector is set to ON.

Changing the display mode

The currently set display mode appears on the VF DISP 1 page of the USER menu. To change it, proceed as follows.

- 1 Follow steps 1 and 2 in 7-2-2 “*Selecting the Display Items*” on page 109, until the VF DISP 1 page of the USER menu appears on the screen.



- 2 Turn the MENU knob to move the ➔ mark to “VF DISPLAY MODE”, and press the MENU knob.
The ➔ mark on the left of “VF DISPLAY MODE” changes to a ● mark and the ● mark on the left of the setting changes to a ? mark.
- 3 Turn the MENU knob until the desired display mode appears, and press the MENU knob.
The ● mark changes to a ➔ mark and the ? mark changes to a ● mark.
- 4 To end the menu operation, set the MENU ON/OFF switch to OFF or close the cover of the menu operating section.

7-2-4 Setting the Marker Display

Use the MARKER 1 page of the USER menu to switch the display of the center and safety zone markers on or off and to select whether the area indicated by the safety zone marker is 80%, 90% or 100% of the screen area.

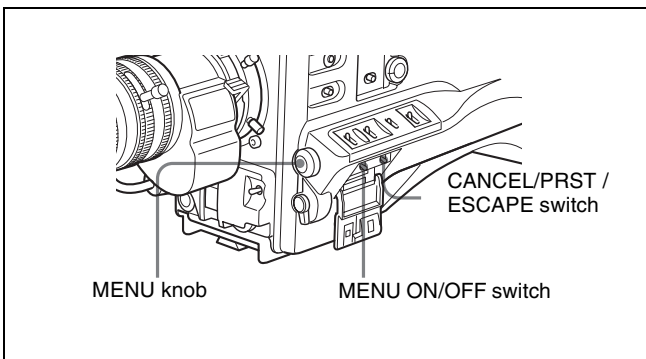

- 1 Set the MENU ON/OFF switch to ON.
The last accessed menu page appears on the screen.
- 2 Turn the MENU knob until the MARKER 1 page appears, and press the MENU knob to select the page.

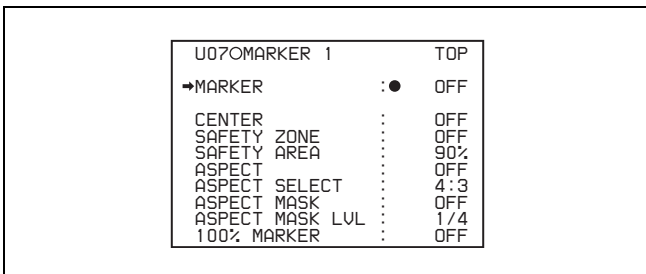

You can set the following items on the MARKER 1 page.

Item	Description
MARKER	Not to display all markers, set to OFF.
CENTER	To display the center marker, set to ON.

Item	Description
SAFETY ZONE	To display the safety zone, set to ON.
SAFETY AREA	To select the safety zone range (80%, 90%, 92.5 % or 95 %), when SAFETY ZONE is set to ON.
ASPECT	To display the aspect marker, set to ON.
ASPECT SELECT	To select the type of the aspect marker.
ASPECT MASK (4:3) ¹⁾	To make the areas out of the selected aspect marker dimmer, set to ON.
ASPECT MASK LVL	To set the mask level (1/2, 1/4 or 1/8), when the ASPECT MASK is set to ON.
100 % MARKER	To display the effective pixel area, set to ON.

1) The ASPECT MASK item is for processing the signal to be output to the viewfinder. When R, G, or B is selected for the TEST OUT SELECT item from the menu, the same video signal is output to the viewfinder and the TEST OUT connector. Thus, when the ASPECT MASK (4:3) item is set to “ON” with R/G/B selected, the masked video signal is output to the TEST OUT connector.

- 3 Perform the settings for each item.
 - ① Turn the MENU knob to move the ➔ mark to the item you want to set, and press MENU knob.
The ➔ mark on the left of the selected item changes to the ● mark and the ● mark on the left of the setting changes to a ? mark.
 - ② Turn the MENU knob to change the setting, and press the MENU knob.
The ● mark on the left of the selected item changes to a ➔ mark and the ? mark on the left of the setting changes to a ● mark.
- 4 To continue setting other items, repeat step 3.
- 5 To end the menu operation, set the MENU ON/OFF switch to OFF or close the cover of the menu operating section.

The menu disappears from the screen, and the display indicating the current status of the camcorder appears along the top and bottom of the screen.

7-2-5 Setting the Viewfinder

Use the VF SETTING page of the USER menu to select items related to the viewfinder.

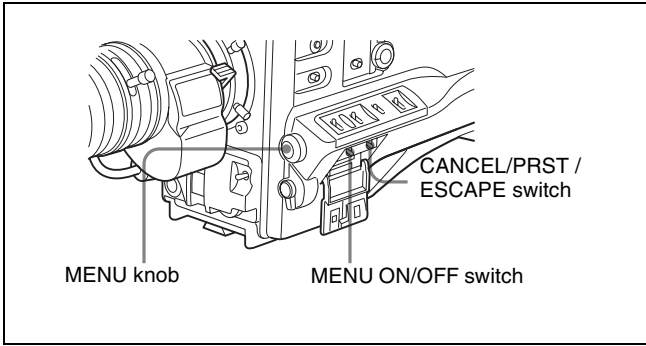

- 1 Set the MENU ON/OFF switch to ON.
The last accessed menu page appears on the screen.
- 2 Turn the MENU knob until the VF SETTING page appears, and press the MENU knob to select the page.

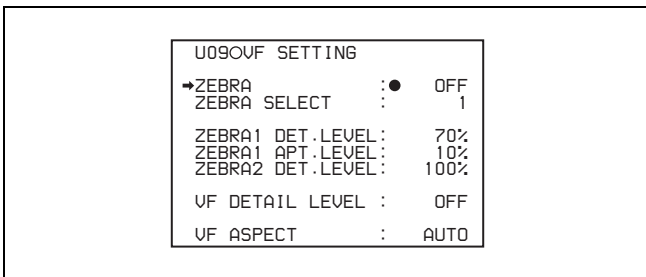

Item	Description
ZEBRA	Turns the zebra display on or off. ¹⁾
ZEBRA SELECT	Selects ZEBRA 1, ZEBRA 2 or BOTH.
ZEBRA 1 DET. LVL	Adjusts the level of the zebra 1 (70%) display.
ZEBRA 1 APT. LVL	Adjusts the aperture level of the zebra 1 display. (1 to 10 to 20)
ZEBRA 2 DET. LVL	Adjusts the level of the zebra 2 (100%) display.
VF DETAIL LEVEL	Adjusts the sharpness of the viewfinder (-99 to 0 to 99). ²⁾ Turns the VF detail function on or off and adjusts the level.
VF ASPECT	Selects the viewfinder aspect ratio. (AUTO/16:9) ³⁾

- 1) When you use the viewfinder which is not equipped with the ZEBRA switch, turns the display on or off using this item. When you use the viewfinder with the ZEBRA switch, the most recent operation of the ZEBRA switch and this menu operation is effective.
- 2) The sharpness setting at the viewfinder does not affect the recorded image.
- 3) When the VF ASPECT item is set to "AUTO", this is linked to the 16:9/4:3 selection on the FORMAT page.
When the VF ASPECT item is set to "16:9", but "4:3" is selected on the FORMAT page, then it is not possible to mix the zebra display and marker display signals on the output signal from the TEST OUT connector.

- 3 Turn the MENU knob to move the ▶ mark to the item you want to set, and press the MENU knob.

The ▶ mark on the left of the selected item changes to a ● mark and the ● mark on the left of the setting changes to a ? mark.

- 4 Turn the MENU knob to change the setting, and press the MENU knob.

The ● mark changes to a ▶ mark and the ? mark changes to a ● mark.

- 5 To continue setting other items, repeat steps 3 and 4.
- 6 To end the menu operation, set the MENU ON/OFF switch to OFF or close the cover of the menu operating section.

The menu disappears from the screen, and the display indicating the current status of the camcorder appears along the top and bottom of the screen.

7-2-6 Recording Shot Data Superimposed on the Color Bars

In the SHOT DISP page of the USER menu, you can select which shot data is recorded superimposed on the color bars. You can also select which of the shot IDs (1 to 4) in the SHOT DATA page is recorded superimposed on the picture.
Proceed as follows.

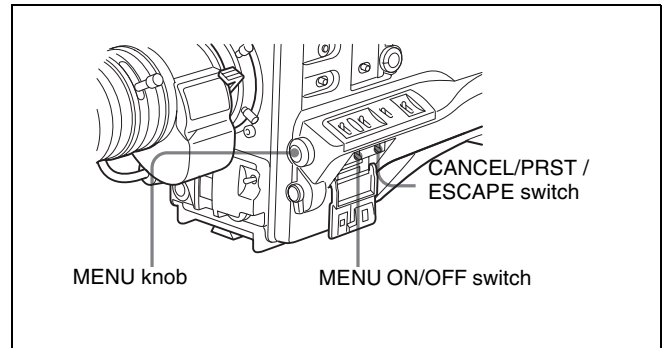

Selecting the shot data for superimposed recording

- 1 Set the MENU ON/OFF switch to ON.
The last accessed menu page appears on the screen.
- 2 Turn the MENU knob until the SHOT DISP page appears, and press the MENU knob to select the page.

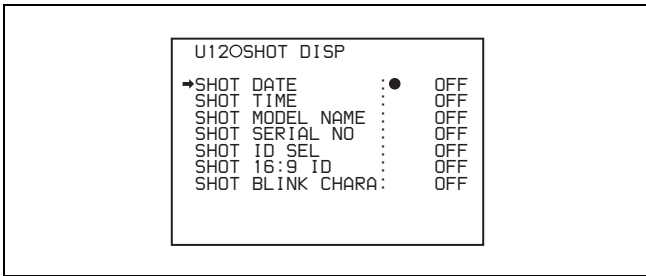

You can set the following items on the SHOT DISP page.

Item	Description
SHOT DATE	Selects whether or not the shot data is superimposed (ON or OFF).
SHOT TIME	Selects whether or not shot time is superimposed (ON or OFF).
SHOT MODEL NAME	Selects whether or not the model name is superimposed (ON or OFF).
SHOT SERIAL NO.	Selects whether or not the serial number is superimposed (ON or OFF).
SHOT ID SEL	Selects whether or not the shot ID set on the SHOT ID ¹⁾ page is superimposed (1 to 4 or OFF).
SHOT 16:9 ID	Selects whether or not the 16:9 mode indicator is superimposed (ON or OFF).
SHOT BLINK CHARA	Selects whether or not the blinking * is superimposed (ON or OFF).

1) To carry out superimposed recording, select the SHOT ID number (1 to 4).
Not to carry out superimposed recording, select "OFF".

3 Turn the MENU knob to move the ➔ mark to the item you want to set, and press MENU knob.

The ➔ mark on the left of the selected item changes to a ● mark and the ● mark on the left of the setting changes to a ? mark.

4 Turn the MENU knob to select whether or not to record the selected item superimposed on the color bars, and press the MENU knob.

The ● mark on changes to a ➔ mark and the ? mark changes to a ● mark.

5 To continue setting other items, repeat steps **3** and **4**.

6 To end the menu operation, set the MENU ON/OFF switch to OFF or close the cover of the menu operating section.

To carry out superimposed recording

To actually record the items selected for superimposed recording on the SHOT DISP page, set the OUTPUT/DCC switch to BARS, DCC OFF.

The items selected for superimposed recording appear on the screen and are recorded superimposed on the color bars.

7-2-7 Setting the Shot ID

On the SHOT ID page of the USER menu, you can set a shot ID of up to 12 alphanumeric characters, spaces, and symbols.

When the OUTPUT/DCC switch is set to BARS, DCC OFF, this shot ID is output with the color bar signal. The shot ID comprises ID1 to ID4, and the setting can be changed using the SHOT DISP page of the USER menu. You can select the SHOT ID to be recorded superimposed on the color bars on the SHOT DISP page.

Note

When the menu is displayed, the shot ID is not displayed even if the color bar signal is output.

To set the shot ID, proceed as follows.

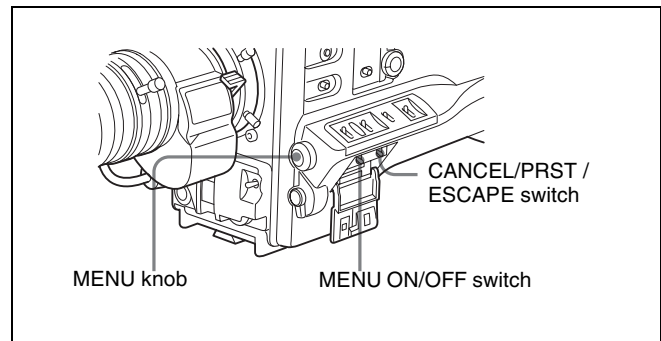

Setting the shot ID

1 Set the MENU ON/OFF switch to ON.

The last accessed menu page appears on the screen.

2 Turn the MENU knob until the SHOT ID page appears, and press the MENU knob to select the page.

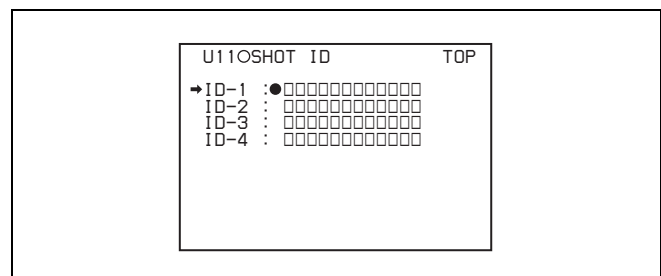

3 Turn the MENU knob to move the ➔ mark to the ID (one of ID-1 to ID-4) you want to set, and press the MENU knob.

A ■ mark appears over the first character position in the string, and characters can now be input.

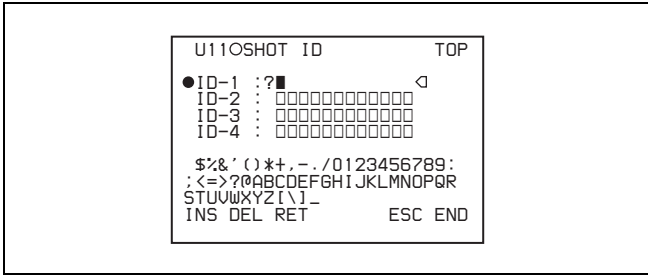

4 Enter or change the shot ID.

When you are entering the whole shot ID, go to step ②.

- ① Turn the MENU knob to move the ■ mark to the character which you want to change, then press the MENU knob. A character table appears.

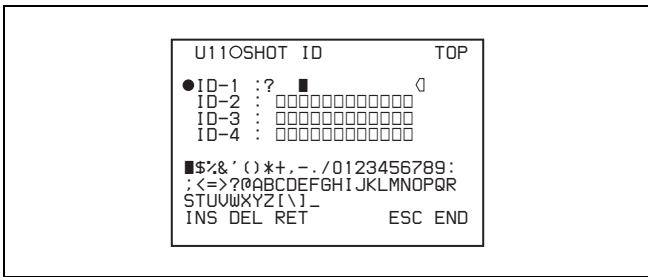

- ② Turn the MENU knob until the ■ mark moves to the character position that you want to select, then press the MENU knob.

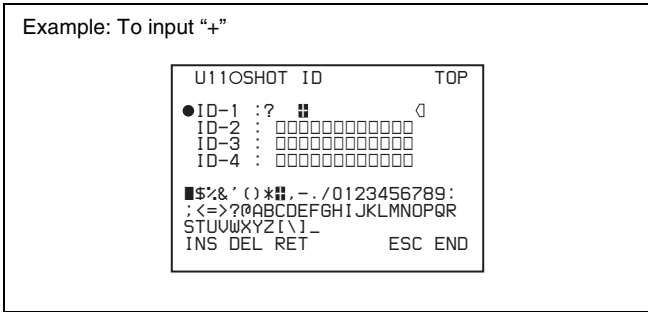

- 5** Repeat step 4 for each of the remaining characters.
- 6** When the input is complete, turn the MENU knob to move the ■ mark over "END", then press the MENU knob.

This ends the input, and returns to the original SHOT ID page.

To insert a space

Proceed as follows.

- 1** In step 4 above, move the ■ mark over "INS", and press the MENU knob.

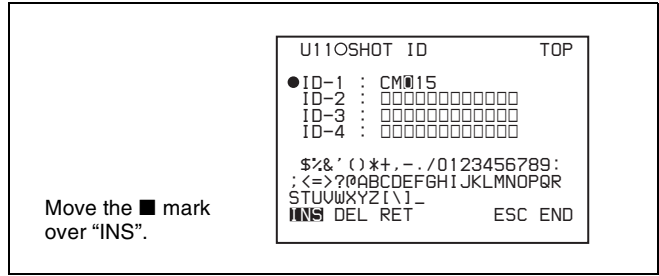

Move the ■ mark over "INS".

- 2** Move the ■ mark over "RET", then press the MENU knob.

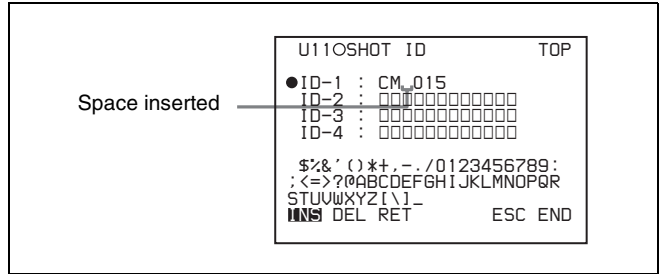

To delete a character

In step 4 of the procedure for setting the shot ID (see page 114), move the ■ mark over "DEL", and press the MENU knob.

This deletes the character under the ■ mark in the shot ID row.

To cancel deleting the character, move the ■ mark over "RET", and press the MENU knob.

To cancel entering or changing shot ID

Before executing step 6 of the procedure for setting the shot ID (see page 114), move the ► mark to "ESC" at the top right of the screen, then press the MENU knob or push the CANCEL/PRST / ESCAPE switch down to ESCAPE. This cancels all changes, and returns to the SHOT ID page.

7-2-8 Displaying the Status Confirmation Windows

You can confirm the settings or status of the camcorder on the screen by displaying the following three windows.

- ABNORMAL <!> window
- FUNCTION window
- AUDIO STATUS window

ABNORMAL <!> window

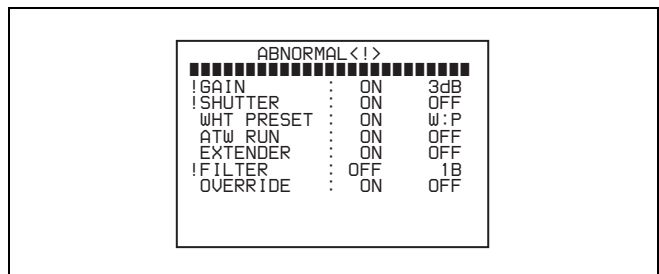

The ➔ mark on the left of the selected item changes to a ● mark and the ● mark on the left of the setting changes to a ? mark.

- 4 Turn the MENU knob to select whether or not to display the selected window, then press the MENU knob.

The ● mark changes to a ➔ mark and the ? mark changes to a ● mark.

- 5 To continue setting other windows, repeat steps 3 and 4.

- 6 To end the menu operation, set the MENU ON/OFF switch to OFF or close the cover of the menu operating section.

7-2-9 Confirming the Image of the Return Video Signal in the Viewfinder

You can set whether or not the image of the return video signal input to the GENLOCK IN connector is displayed in the viewfinder, using the GENLOCK page of the MAINTENANCE menu.

Proceed as follows.

- 1 Set the MENU ON/OFF switch to ON while holding down the MENU knob.

The TOP menu appears.

- 2 Turn the MENU knob to move the ➔ mark to “MAINTENANCE”, then press the MENU knob.

If this is the first time the MAINTENANCE menu has been displayed, the CONTENTS page of the MAINTENANCE menu appears.

If the menu has been used before, the last accessed page appears.

- 3 If the CONTENTS page is displayed, turn the MENU knob to move the ➔ mark to “GENLOCK”, then press the MENU knob to display the GENLOCK page.

If a different page is displayed, turn the MENU knob until the GENLOCK page appears, then press the MENU knob to select the page.

M150GENLOCK		TOP
➔GENLOCK	: ●	ON
RETURN VIDEO	:	OFF
GL H PHASE	:	0
GL SC PHASE	:	0
GL SC 0/180 SEL	:	180

- 4 Carry out setting operations as follows.

- ① Turn the MENU knob to move the ➔ mark to “GENLOCK”, and press the MENU knob.
The ➔ mark on the left of “GENLOCK” changes to a ● mark and the ● mark on the left of the GENLOCK setting changes to a ? mark.

- ② Turn the MENU knob until “OFF” appears, then press the MENU knob.
The ● mark changes to a ➔ mark and the ? mark changes to a ● mark, and the setting is executed.

- ③ Turn the MENU knob to move the ➔ mark to “RETURN VIDEO”, and press the MENU knob.
The ➔ mark changes to a ● mark and the ● mark changes to a ? mark.

- ④ Turn the MENU knob until “ON” appears, then press the MENU knob.
The ● mark changes to a ➔ mark and the ? mark changes to a ● mark, and the setting is executed.

- 5 To end the menu operation, set the MENU ON/OFF switch to OFF or close the cover of the menu operating section.

To see the image of the return video signal on the viewfinder screen

Hold down the RET switch on the lens. The image of the return video signal input to the GENLOCK IN connector is displayed on the viewfinder screen while you are holding down the RET switch.

When the return video function is assigned to the ASSIGN 1/3/4 switch, you can see the image of the return video signal on the viewfinder screen while you are holding down the ASSIGN 1/3/4 switch even if the RETURN VIDEO item is set to “OFF” on the GENLOCK page of the MAINTENANCE menu.

Note

When no signal is input to the GENLOCK IN connector, the image is not changed even if you hold down the RET switch on the lens.

However, the image is switched while you are holding down the ASSIGN 1/3/4 switch to which the return video function is assigned, even if no signal is input to the GENLOCK IN connector.

7-3 Adjustments and Settings from Menus

The camcorder provides menus for adjustments and settings.

7-3-1 Setting Gain Values for the GAIN Selector Positions

Before using the camcorder, use the GAIN SW page of the USER menu to set the gains corresponding to the L, M, and H positions of the GAIN selector, which switches the gain of the video amplifier.

To set the gain values, proceed as follows.

- 1 Set the MENU ON/OFF switch to ON.
The last accessed menu page appears on the screen.
- 2 Turn the MENU knob until the GAIN SW page appears, then press the MENU knob to select the page.

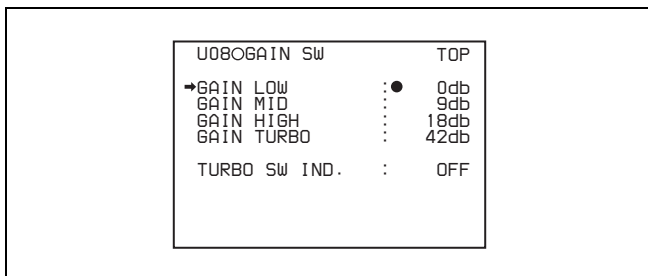

Item	Description
GAIN LOW	Sets the gain value corresponding to the L position of the GAIN selector.
GAIN MID	Sets the gain value corresponding to the M position of the GAIN selector.
GAIN HIGH	Sets the gain value corresponding to the H position of the GAIN selector.
GAIN TURBO	Sets the gain value corresponding to TURBO GAIN button selection.
TURBO SW IND	OFF: When you operate the GAIN selector after pressing the TURBO GAIN button once, the video gain is changed according to the GAIN selector operation. ON: When the video gain is boosted to the video gain to the value preset by pressing the TURBO GAIN button once, the video gain is not changed even if you operate the GAIN selector, until you press the TURBO GAIN button once more.

- 3 Turn the MENU knob to move the ▶ mark to the item you want to set, and press MENU knob.

The ▶ mark on the left of the selected item changes to a ● mark and the ● mark on the left of the setting changes to a ? mark.

- 4 Turn the MENU knob to change the setting, and press the MENU knob.

The ● mark on the left of the selected item changes to a ▶ mark and the ? mark on the left of the setting changes to a ● mark.

Any of -3, 0, 3, 6, 9, 12, 18, 24, 30, 36, 42 or 48 dB can be set for each of the L, M, and H positions, in any sequence.

For TURBO, any of -3, 0, 3, 6, 9, 12, 18, 24, 30, 36, 42 or 48 dB can be selected.

To change the gain corresponding to another switch position, return to step 3.

- 5 To end the menu operation, set the MENU ON/OFF switch to OFF or close the cover of the menu operating section.

The menu display disappears, and the current status of the camcorder is shown along the top and bottom of the screen.

7-3-2 Selecting the Output Signals

When the CBK-SD01 is installed, you can select the type of video signals (VBS/SDI) from the VIDEO OUT connector on the OUTPUT page of the USER menu. Use the POWER SAVE page to specify whether or not to enable DV stream output from the i.LINK DV IN/OUT S400 connector of this unit.

When DV stream output is enabled, it is output when the recording format is any of MPEG IMX 50Mbps, 40Mbps, 30Mbps or DVCAM.

To select the signal output from the VIDEO OUT connector

Proceed as follows.

- 1 Set the MENU ON/OFF switch to ON.
The last accessed menu page appears on the screen.
- 2 Turn the MENU knob until the OUTPUT page appears, then press the MENU knob to select the page.

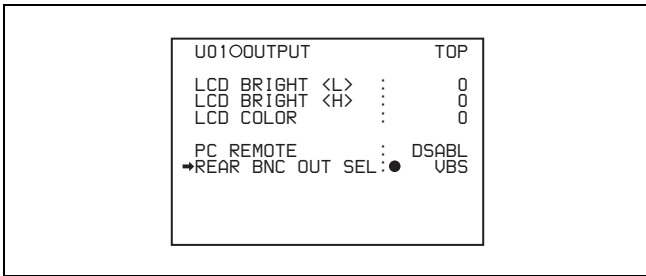

Item	Description
LCD BRIGHT <L>	Adjusts the LCD brightness when the LCD switch is in the L position.
LCD BRIGHT <H>	Adjusts the LCD brightness when the LCD switch is in the H position.
LCD COLOR	Adjusts the color saturation of the LCD.
i.LINK SBP2 MODE	Selects whether or not to use the i.LINK connector SBP2 interface.
REAR BNC OUT SEL	Selects the type of the video signal to be output from the VIDEO OUT connector. SDI : Outputs the SDI signal. When SDI is selected, connect the VIDEO OUT connector to the SDI IN connector of the video monitor. VBS: Outputs the analog composite video signal. When VBS is selected, connect the VIDEO OUT connector to the VIDEO IN connector of the video monitor. This setting allows you to save the power.

3 Turn the MENU knob to move the ➔ mark to “REAR BNC OUT SEL”, and press the MENU knob.

The ➔ mark on the left of “REAR BNC OUT SEL” changes to a ● mark and the ● mark on the left of the setting changes to a ? mark.

4 Turn the MENU knob to change the desired setting, and press the MENU knob.

The ● mark on the left of the selected item changes to a ➔ mark and the ? mark on the left of the setting changes to a ● mark.

5 To end the menu operation, set the MENU ON/OFF switch to OFF or close the cover of the menu operating section.

To enable DV stream output

Proceed as follows.

1 Holding down the MENU knob, move the MENU ON/OFF switch to ON.

The TOP menu appears.

2 Turn the MENU knob to move the ➔ mark to “OPERATION”, then press the MENU knob.

If this is the first time the OPERATION menu has been displayed, the CONTENTS page appears. If the menu has been used before, the last accessed page appears.

3 If the CONTENTS page is displayed, turn the MENU knob to move the ➔ mark to POWER SAVE, then press the MENU knob.

If a different page is displayed, turn the MENU knob until the POWER SAVE page appears, then press the MENU knob.

The POWER SAVE page appears. The current settings appear on the right side of each item.

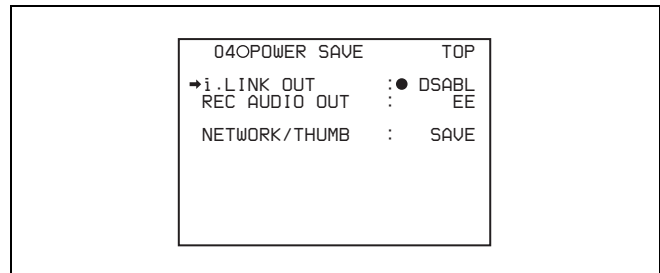

Item	Setting
i.LINK OUT	Enable or disable i.LINK (AV/C) OUT.
REC AUDIO OUT	Select whether to output E-E signals or no audio from the AUDIO OUT connector during recording.
NETWORK/THUMB	Select whether to permanently enable the CBK-NC01 (option) and thumbnail display, or to disable them in power saving mode.

4 Move the ➔ mark to “i.LINK OUT”, then press the MENU knob.

The ➔ mark changes to a ● mark, and the ● mark changes to a ? mark.

5 Turn the MENU knob to select “ENABL”, then press the MENU knob.

The setting is confirmed. The ● mark changes to a ➔ mark and the ? mark changes to a ● mark.

6 To end the menu operation, set the MENU ON/OFF switch to OFF.

7-3-3 Setting the Color Temperature Manually

You can adjust the value of the white balance manually by setting the color temperature. Proceed as follows.

- 1 Holding down the MENU knob, move the MENU ON/OFF switch to ON.

The TOP menu appears.

- 2 Turn the MENU knob to move the ➔ mark to “PAINT”, and press the MENU knob.

If this is the first time the PAINT menu has been displayed, the CONTENTS page appears. If the menu has been used before, the last accessed page appears.

- 3 If the CONTENTS page is displayed, turn the MENU knob to move the ➔ mark to “WHITE”, and press the MENU knob to display the WHITE page.

If a different page is displayed, turn the MENU knob until the WHITE page appears, and press the MENU knob to select the page.

P020WHITE	
➔COLOR TEMP <A>	● 3200
COLOR FINE <A>	0
R GAIN <A>	0
B GAIN <A>	0
D5600K <A>	OFF
COLOR TEMP 	3200
COLOR FINE 	0
R GAIN 	0
B GAIN 	0
D5600K 	OFF

Item	Description
COLOR TEMP <A>	Sets the color temperature for the desired value. Adjust the value while looking at the real image because error tends to be bigger for adjustment of high color temperature.
COLOR FINE <A>	Adjusts the value more precisely when the color temperature adjustment through COLOR TEMP is not satisfactory.
R GAIN <A>	Only the value of R GAIN is changed.
B GAIN <A>	Only the value of B GAIN is changed.
D5600K	Sets the color temperature to approximately 5600 K.

The above table shows the adjustment of the white balance of channel A.

Items followed by “” are used to adjust the white balance of channel B.

- 4 Turn the MENU knob to move the ➔ mark to the item you want to set, and press MENU knob.

The ➔ mark on the left of the selected item changes to a ● mark and the ● mark on the left of the setting changes to a ? mark.

- 5 Turn the MENU knob to change the setting, and press the MENU knob.

The ● mark changes to a ➔ mark and the ? mark changes to a ● mark.

To set other items, go back to step 3.

- 6 To end the menu operation, set the MENU ON/OFF switch to OFF or close the cover of the menu operating section.

7-3-4 Specifying an Offset for the Auto White Balance Setting

By setting an offset for the value of auto white balance, you can make the picture warmer or colder.

The OFFSET WHT page of the OPERATION menu allows you to do this setting.

Proceed as follows.

- 1 Holding down the MENU knob, move the MENU ON/OFF switch from OFF to ON.

The TOP menu appears.

- 2 Turn the MENU knob to move the ➔ mark to “OPERATION”, and press the MENU knob.

If this is the first time the OPERATION menu has been displayed, the CONTENTS page appears. If the menu has been used before, the last accessed page appears.

- 3 If the CONTENTS page is displayed, turn the MENU knob to move the ➔ mark to “OFFSET WHITE”, and press the MENU knob to display the OFFSET WHITE page.

If a different page is displayed, turn the MENU knob until the OFFSET WHITE page appears, and press the MENU knob to select the page.

P17●OFFSET WHT		TOP
➔OFFSET WHITE <A>	●	OFF
WARM COOL <A>	:	3200
COLOR FINE <A>	:	0
OFFSET WHITE 	:	OFF
WARM COOL 	:	3200
COLOR FINE 	:	0

Item	Description
OFFSET WHITE <A>	Turns the setting of the offset for channel A ON or OFF. ON: Adds the offset adjusted on this page to the white balance.
WARM-COOL <A>	When OFFSET WHITE <A> is ON, sets the offset for the white balance of channel A, using the color temperature. Adjust the value while looking at the real image because error tends to be bigger for adjustment of high color temperature.

Item	Description
COLOR FINE <A>	Adjusts the value more precisely if the adjustment by WARM-COOL <A> is not satisfactory.
OFFSET WHITE 	Turns the setting of the offset for channel B ON or OFF. ON: Adds the offset adjusted on this page to the white balance.
WARM-COOL 	Sets the offset for the white balance of channel B, using the color temperature. Adjust the value while looking at the real image because error tends to be bigger for adjustment of high color temperature.
COLOR FINE 	Adjusts the value more precisely if the adjustment by WARM-COOL is not satisfactory.

- 4 Set the WHITE BAL switch to the position corresponding to the desired channel (A or B).

Note

If the WHITE BAL switch is not set to A or B when you operate the camcorder, the adjustment value will not be reflected in the output signal.

- 5 Turn the MENU knob to move the \blacktriangleright mark to the item you want to set, and press MENU knob.

The \blacktriangleright mark on the left of the selected item changes to a \bullet mark and the \bullet mark on the left of the setting changes to a ? mark.

- 6 Turn the MENU knob to change the setting, and press the MENU knob.

The \bullet mark changes to a \blacktriangleright mark and the ? mark changes to a \bullet mark.

To set other items, go back to step 3.

To set the other white balance channel, go back to step 2.

- 7 To end the menu operation, set the MENU ON/OFF switch to OFF or close the cover of the menu operating section.

7-3-5 Assigning Functions to ASSIGN 1/2/3/4 Switches

You can assign the desired function to any of the ASSIGN 1/2/3/4 switches and the TURBO GAIN button. Proceed as follows.

- 1 Set the MENU ON/OFF switch to ON.

The last accessed menu page appears on the screen.

- 2 Turn the MENU knob until the FUNCTION 1 page appears, then press the MENU knob to select to page.

U030FUNCTION1	TOP
ASSIGN SW <1>	ATW
ASSIGN SW <2>	OFF
ASSIGN SW <3>	OFF
ASSIGN SW <4>	OFF
TURBO SW	TURBO
DF/NDF	DF
CACHE/INTVAL	OFF

Item	Description
ASSIGN SW 1	Assigns the function to ASSIGN 1 (push-type) switch.
ASSIGN SW 2	Assigns the function to ASSIGN 2 (slide-type) switch.
ASSIGN SW 3	Assigns the function to ASSIGN 3 (push-type) switch.
ASSIGN SW 4	Assigns the function to ASSIGN 4 (push-type) switch.

- 3 Turn the MENU knob to move the \blacktriangleright mark to the item corresponding to the switch to which you want to assign the function, and press the MENU knob.

The corresponding ASSIGN SW SEL window appears.

ASSIGN SW1 <3/4> SEL window

ASSIGN SW1 SEL ESC
\blacktriangleright OFF
PICTURE CACHE ON/OFF
TEST OUT CHARACTER
MARKER
RE-TAKE
ATW
RETURN VIDEO
LENS RET
REC SWITCH
TURBO SWITCH

ASSIGN SW2 SEL window

ASSIGN SW2 SEL ESC
\blacktriangleright OFF
PICTURE CACHE ON/OFF
TEST OUT CHARACTER
MARKER
ZEBRA
FREEZE MIX
FREEZE MIX (Manual)
D5600
EXT REC CONTROL

Functions to be assigned to the ASSIGN 1/3/4 (push-type) switch

Function	Description
OFF	Disables the switch.
CACHE	Assigns execution of recording in picture cache mode.

Function	Description
TEST OUT CHARACTER	Assigns the function to switch whether or not text is superimposed on the video signal to be output from the TEST OUT connector.
MARKER	Assigns the ON/OFF function to display all markers. ¹⁾
RETAKE	Assigns the function to delete the last recorded clip.
ATW	Assigns the ON/OFF function of auto-tracing white balance.
RETURN VIDEO	Assigns the ON/OFF function to display the image of the return video signal on the viewfinder to the switch. ²⁾
LENS RET	Assigns the same function as that of the RET switch on the lens to the switch.
REC SWITCH	Assigns the VTR S/S (start/stop) function to the switch.
TURBO SWITCH	Assigns the turbo gain function to the switch.
ZEBRA	Assigns the zebra pattern display function to the switch.
FREEZE MIX	Outputs the freeze image and camera input alternately, to allow frame alignment (automatic switching).
FREEZE MIX (Manual)	Outputs the freeze image and camera input alternately, to allow frame alignment (manual switching).
D5600	Applies an electrical 5600 K filter.
ZOOM TELE/WIDE ³⁾	When using a serial lens, assign the ZOOM TELE setting to ASSIGN 3, and the WIDE setting to ASSIGN 4.
ZOOM WIDE/TELE ³⁾	When using a serial lens, assign the ZOOM WIDE setting to ASSIGN 3, and the TELE setting to ASSIGN 4.
SHOT MARK1	Assigns the function to record a SHOT MARK 1 essence mark.
SHOT MARK2	Assigns the function to record a SHOT MARK 2 essence mark.
UA01 to UA10 ⁴⁾	Assigns the items assigned in the ASSIGN SEL menu.

1) Even when the MARKER item is set to "OFF" on the MARKER page of the USER menu, the ASSIGN 1/3/4 switch allows you to display or not to display all markers.

2) Even if the RETURN VIDEO item is set to "OFF" on the GENLOCK page of the MAINTENANCE menu, you can use this switch to display the image of the return video signal on the viewfinder.

3) Only the Assign 3SEL and Assign 4 SEL screens appear.

4) This does not appear if nothing is assigned in the Assign menu.

Functions to be assigned to the ASSIGN 2 (slide-type) switch

Function	Content
OFF	Disables the switch.
CACHE	Assigns execution of recording in picture cache mode.

Function	Content
TEST OUT CHARACTER	Assigns the function to switch whether or not the characters are mixed to the video signal to be output from the TEST OUT connector.
MARKER	Assigns the ON/OFF function to display all markers. ¹⁾
ZEBRA	Assigns the zebra pattern display function to the switch.
D5600	Applies an electrical 5600 K filter.
EXT REC CONTROL	Selects whether or not recording control of external devices connected through the i.LINK connector or the CCZ connector (26-pin) of a CA-702 is possible.
REC VIDEO SOURCE ²⁾	Selects which signals you will record pictures being shot by the camcorder or video signals from external equipment connected to GENLOCK IN connector.
UA01 to UA10 ³⁾	Assigns the items assigned in the ASSIGN SEL menu.

1) Even when the MARKER item is set to "OFF" on the MARKER page of the USER menu, the ASSIGN 2 switch allows you to display or not to display all markers.

2) When the CBK-SC01 is not installed, this item does not appear since this function is not effective.

3) This does not appear if nothing is assigned in the Assign menu.

Note

For functions that are assigned to the ASSIGN 2 switch, you cannot change those settings using other menus. The function assigned to ASSIGN 2 switch takes precedence over the menu setting.

- Turn the MENU knob to move the ➔ mark to the item you want to set, and press MENU knob.

The ➔ mark changes to a ● mark, and the ● mark by the setting changes to a ? mark.

- Turn the MENU knob to switch to the desired setting, and press the MENU knob.

The ● mark changes to a ➔ mark, and the ? mark changes to a ● mark, confirming the setting.

- To continue with other settings, repeat steps 3 and 4.

To return to the previous page

Turn the MENU knob to move the ➔ mark to "ESC" at the right top of the window and press the MENU knob. Alternatively, push the CANCEL/PRST / ESCAPE switch down to the ESCAPE side.

To end the menu operation

Set the MENU ON/OFF switch to OFF or close the cover of the menu operating section.

Operation of the ASSIGN 1/2/3/4 switches when UA01 to UA10 are assigned

When an on/off switchable function (or menu item) is assigned to one of the ASSIGN 1/2/3/4 switches, each time the switch is pressed toggles the function on or off.

When another type of menu item is assigned, pressing the switch displays the item and its setting value on the viewfinder screen.

You can then change the setting by pressing and turning the MENU knob.

The viewfinder screen display disappears approximately three seconds after the last operation.

7-3-6 Setting the Date/Time of the Internal Clock

You can set or change the date and time of the internal clock. The date and time set are reflected in the time code. Proceed as follows.

- 1 Holding down the MENU knob, move the MENU ON/OFF switch to ON.

The TOP menu appears.

- 2 Turn the MENU knob to move the \blacktriangleright mark to “DIAGNOSIS”, and press the MENU knob.

If this is the first time the DIAGNOSIS menu has been displayed, the CONTENTS page appears. If the menu has been used before, the last accessed page appears.

- 3 If the CONTENTS page is displayed, turn the MENU knob to move the \blacktriangleright mark to “TIME/DATE”, and press the MENU knob to display the TIME/DATE page.

If a different page is displayed, turn the MENU knob until the TIME/DATE page appears, then press the MENU knob to select the page.

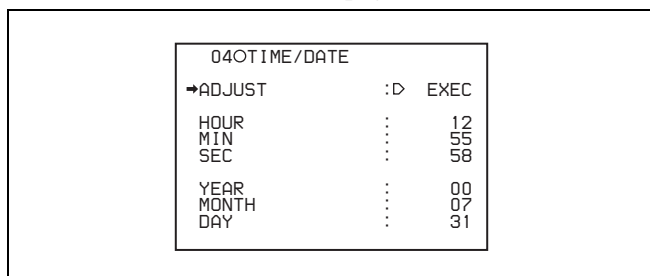

- 4 Press the MENU knob.

The TIME ADJUST setting window appears.

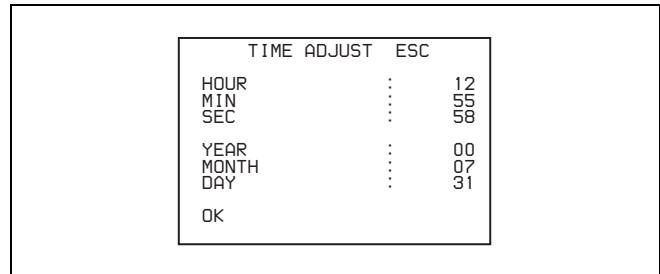

Item	Description
HOUR	Sets the hour value.
MIN	Sets the minutes value.
SEC	Sets the seconds value.
YEAR	Sets the year.
MONTH	Sets the month.
DAY	Sets the day.

- 5 Turn the MENU knob to move the \blacktriangleright mark to the item you want to set, and press MENU knob.

The \blacktriangleright mark on the left of the selected item changes to a \bullet mark and the \bullet mark on the left of the setting changes to a ? mark.

- 6 Turn the MENU knob to display the desired value, and press the MENU knob.

The \bullet mark changes to a \blacktriangleright mark and the ? mark changes to a \bullet mark.

- 7 To continue the remaining settings, repeat steps 5 and 6.

- 8 When you finish settings, turn the MENU knob to move the \blacktriangleright mark to “OK”, then press the MENU knob.

The internal clock is set with the date and time set in steps 5 to 7. The TIME/DATE page of the DIAGNOSIS menu appears again. The time set on the TIME ADJUST setting window is displayed.

To cancel the setting

Before executing step 8, move the \blacktriangleright mark to “ESC” at the top right of the window and press the MENU knob. Alternatively, push the CANCEL/PRST / ESCAPE switch down to the ESCAPE side.

All settings or changes are discarded and the TIME/DATE page of the DIAGNOSIS menu appears.

7-3-7 Selecting the Lens File

The LENS FILE page of the USER menu allows you to change the lens file according to the lens in use.

When you are using a serial lens, you can automatically load the lens file number corresponding to your lens by

setting *LENS AUTO RECALL* in the *LENS FILE 1* page of the *FILE* menu to *ON*.

Proceed as follows to select the lens file.

- 1 Set the MENU ON/OFF switch to ON.
The last accessed menu page appears on the screen.
- 2 Turn the MENU knob until the LENS FILE page appears, then press the MENU knob to select the page.
The LENS FILE page shows the number and the name of the currently selected lens file.

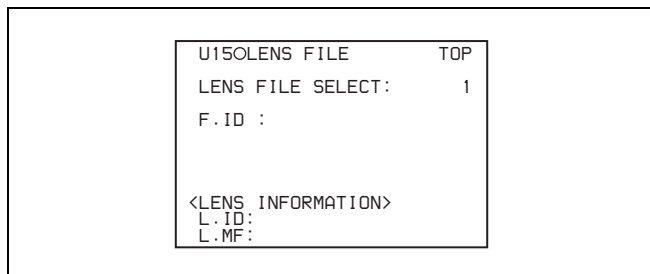

- 3 Turn the MENU knob to move the ▶ mark to LENS FILE SELECT, and press the MENU knob.
The ▶ mark on the left of the selected item changes to a ● mark and the ● mark on the left of the setting changes to a ? mark.
- 4 Turn the MENU knob until the lens file No. in use appears, then press the MENU knob.
The ● mark changes to a ▶ mark and the ? mark changes to a ● mark.

If you do not want to use a lens file
Select NO OFFSET.
- 5 To end the menu operation, set the MENU ON/OFF switch to OFF or close the cover of the menu operating section.

7-3-8 Selecting the Aspect Ratio

The FORMAT page of the OPERATION menu allows you to select the aspect ratio of the video output signal.

Note

When the CA-701/702/702P camera adaptor is used with the camcorder, this function is not available. To select the aspect ratio, disconnect the CA-701/702/702P camera adaptor from the camcorder or turn off the power of the CA-701/702/702P camera adaptor.

Proceed as follows.

- 1 Follow the procedure of steps 1 to 3 described in 7-3-4 “Specifying an Offset for the Auto White Balance Setting” on page 119 to display the FORMAT page of the OPERATION menu.

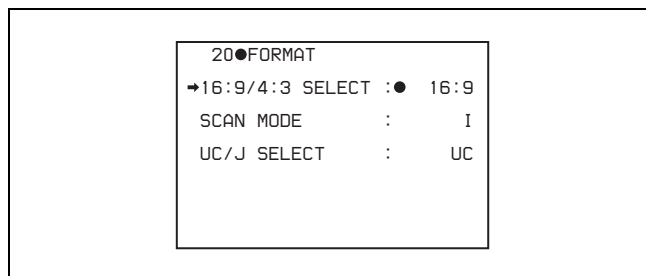

- 2 Turn the MENU knob to move the ▶ mark to “16:9/4:3 SELECT”, and press MENU knob.
The ▶ mark on the left of the selected item changes to a ● mark and the ● mark on the left of the setting changes to a ? mark.
- 3 Turn the MENU knob to display the desired aspect ratio, and press the MENU knob.
The ● mark changes to a ▶ mark and the ? mark changes to a ● mark.
- 4 To end the menu operation, set the MENU ON/OFF switch to OFF or close the cover of the menu operating section.

To display the aspect ratio of 16:9/4:3 on the viewfinder screen

By setting the “DISP 16:9/4:3 ID” item on the VF DISP 2 page of the USER menu to “ON”, “16:9” or “4:3” appears on the viewfinder screen when the aspect ratio of 16:9 is selected.

For details, see 7-2-2 “Selecting the Display Items” on page 109.

To display “16:9” in color bars

By setting the “SHOT 16:9 ID” on the SHOT DISP page of the USER menu to ON, you can record a “16:9” mode indicator superimposed on the color bars.

For details, see 7-2-6 “Recording Shot Data Superimposed on the Color Bars” on page 112.

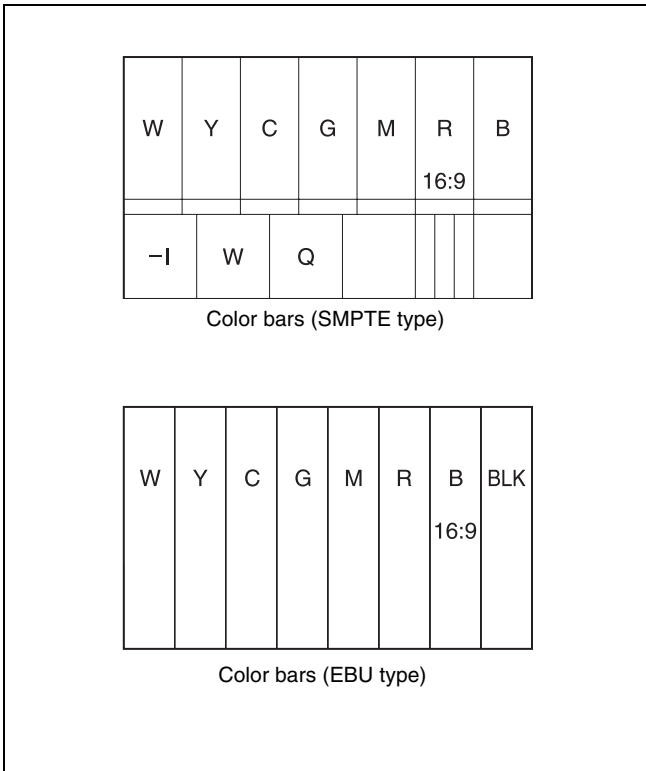

16:9 mode indicator on the color bar display

7-3-9 Setting the CCD Scan Mode

Since the camcorder has CCDs that use an “all pixels read-out method,” a progressive scan mode is also available in addition to the conventional interlace scan mode. You can select either of the following modes using the FORMAT page of the OPERATION menu.

- I (interlace scan) mode

I (interlace scan) mode

- PsF (progressive scan) mode
Installing the CBK-FC01 allows you to select the 24P mode.

Each mode is described below using timing charts.

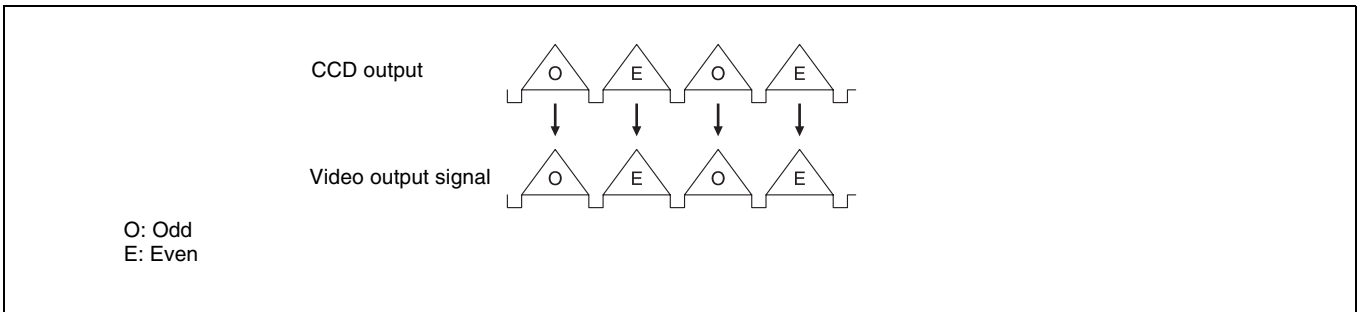

Interlace scan mode timing chart

The video signal of an odd scanning line and that of an even scanning line are output from the CCD alternately. Thus, the timing of the odd-field video signal and even-field video signal are different.

PsF (progressive scan) mode

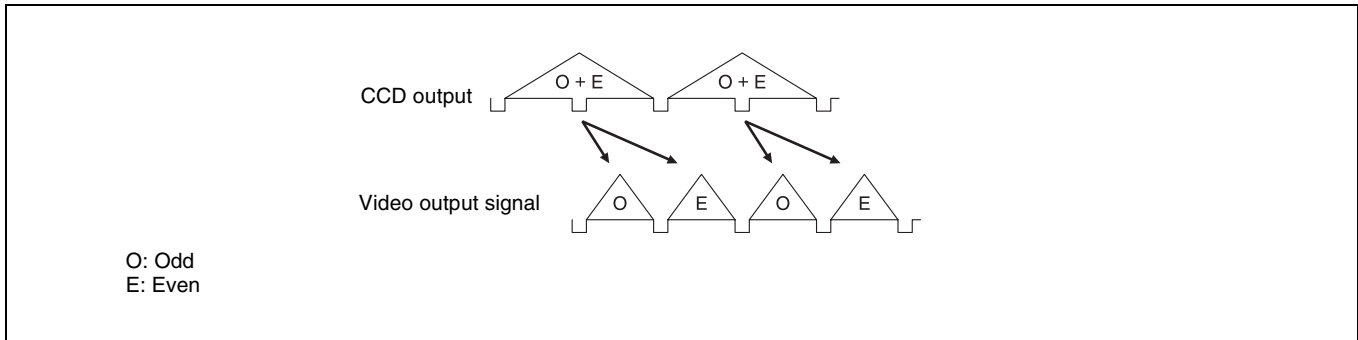

Progressive scan mode timing chart

The video signal of an odd scanning line and that of an even scanning line are output from the CCD at the same time. Then they are sent to the memory and separated into

odd-field and even-field scanning lines. Thus the timing of an odd-field video signal and an even-field video signal are the same.

24P mode (2-3 pull-down) mode (PDW-510/530 only)

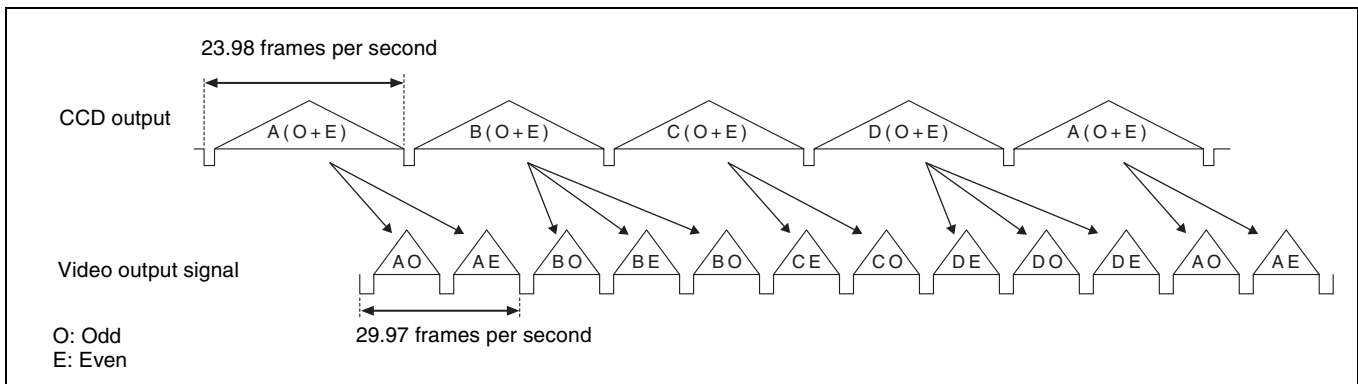

24P mode timing chart

After reading from the CCDs in 24P mode (23.98 frames per second), a pull-down conversion is carried out to the 30

frames (29.97 frames per second) of the normal progressive scan mode.

Setting the CCD scan mode

The scan mode of the camcorder has been set to the interlace scan mode at the factory. The FORMAT page of the OPERATION menu allows you to change the CCD scan mode to the progressive scan mode or 24P mode (PDW-510/530 only).

- 1 Follow the procedures given in steps 1 to 3 described in 7-3-4 “Specifying an Offset for the Auto White Balance Setting” on page 119, to display the FORMAT page of the OPERATION menu.
- 2 Turn the MENU knob to move the ➔ mark to “SCAN MODE”, and press the MENU knob.

The ➔ mark on the left of “SCAN MODE” changes to a ● mark and the ● mark on the left of the setting changes to a ? mark.

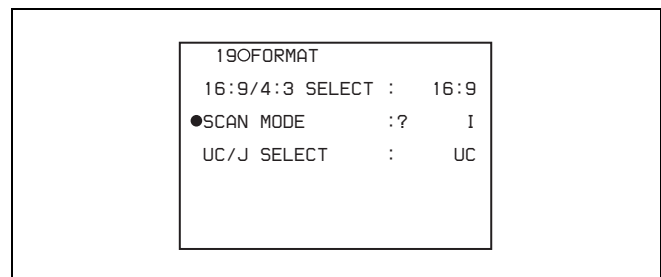

- 3 Turn the MENU knob to display “PsF” or “24P”, and press the MENU knob.

The ● mark changes to a ➔ mark and the ? mark changes to a ● mark.

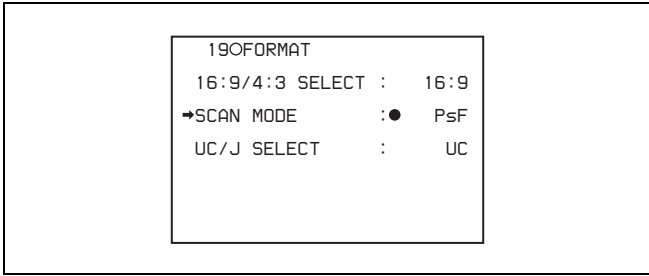

4 To end the menu operation, set the MENU ON/OFF switch to OFF.

7-3-10 Using UMID Data

To perform operations from interviewing to editing effectively and to detect audio-visual materials easily when reusing them, metadata that provides additional information is recorded along with audio-visual data on a disc. As one of application of metadata, the UMID (Unique Material Identifier) is internationally standardized.

What is a UMID?

The UMID (Unique Material Identifier) is a unique identifier for audio-visual material defined by the SMPTE330M-2003 standard.

The UMID may be used either as the 32-byte Basic UMID or as the extended UMID, which includes an additional 32 bytes of Source Pack to make a total 64 bytes.

For details, refer to SMPTE 330M.

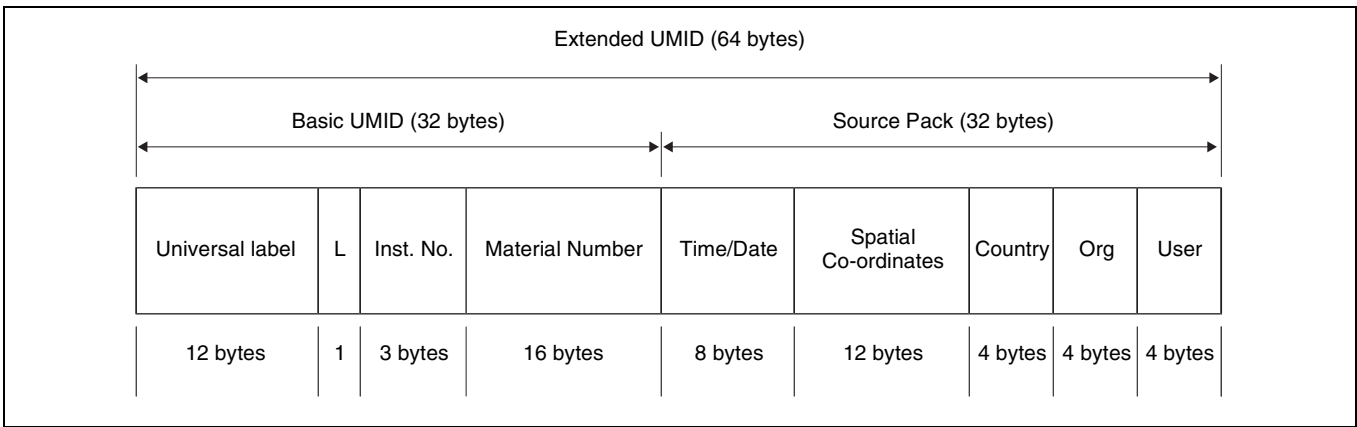

Globally unique ID is automatically recorded every shooting.

The Extended UMID is metadata that provides additional information such as location, time/date, company and so on.

The UMID is applied as follows.

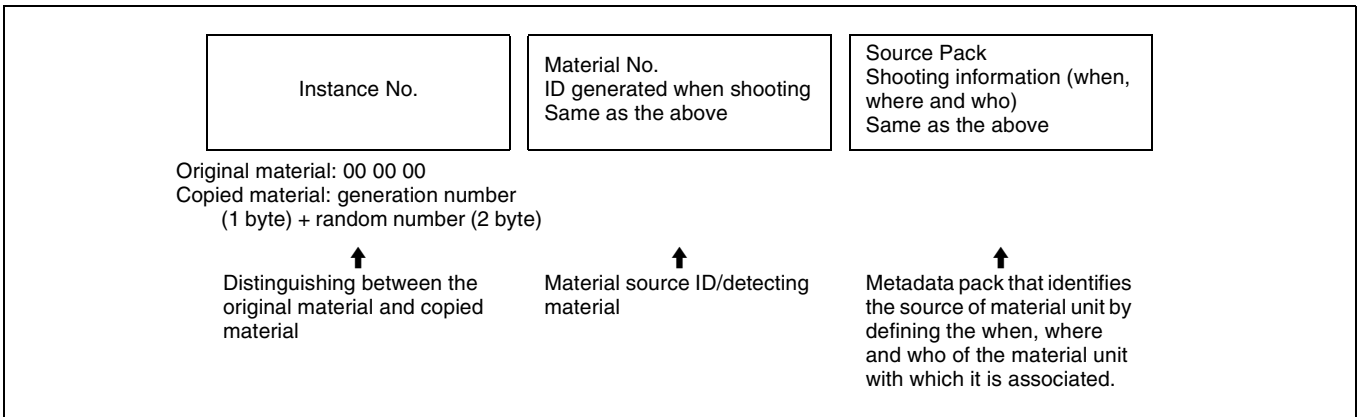

Using the Extended UMID

You have to enter a country code, organization code and user code. Set the country code referring to the ISO-3166

table, and set the organization code and user code independently.

For details, see “UMID Menu Setup” on page 127.

Functions of UMID data

The UMID data enables the followings:

- Add a globally unique ID to every shot of audio-visual material. The unique ID is used to detect the material source and to link it with the original source material.
- Distinguishing between original material and copied material. 00 is added to the Instance Number for original material.
- Recording based on the UTC. The UTC is used when recording the UMID. This enables uniform control of source material recorded all over the world based on the universal time code.
- Calculating the date difference among source materials. The source material is recorded based on the MJD (Modified Julian Date), which enables easy calculation of date difference among source materials.

UMID Menu Setup

The UMID SET page of the OPERATION menu allows you to make settings for UMID data.

Proceed as follows.

- 1 Holding down the MENU knob, set the MENU ON/OFF switch from OFF to ON.

The TOP menu appears.

- 2 Turn the MENU knob to move the ➔ mark to “OPERATION”, and press the MENU knob.

If this is the first time the Operation menu has been displayed, the CONTENTS page appears.

If the menu has been used before, the last accessed page appears.

- 3 If the CONTENTS page is displayed, turn the MENU knob to move the ➔ mark to “UMID SET”, and press the MENU knob.

If a different page is displayed, turn the MENU knob until the UMID SET page appears, then press the MENU knob.

The UMID SET page appears.

The current settings appear on the right side of each item.

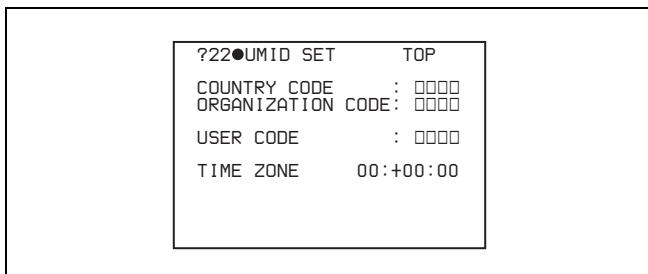

Proceed as follows.

Item	Contents
COUNTRY CODE	Sets the country code.
ORGANIZATION	Sets the organization code.
USER CODE	Sets the user code.
TIME ZONE	Sets the time difference from UTC.

- 4 Turn the MENU knob to move the ➔ mark to the item you want to set, and press the MENU knob.

The ➔ mark to the left of the selected item changes to a ● mark and the ● mark to the left of the setting changes to a ? mark.

- 5 Turn the MENU knob to change the setting of the selected item or to display the desired value, and press the MENU knob.

The ● mark changes to a ➔ mark and the ? mark changes to a ● mark.

- 6 To end the menu operation, set the MENU ON/OFF switch to OFF.

Additional information related to the UMID

COUNTRY CODE

When you select this item, the COUNTRY CODE window appears.

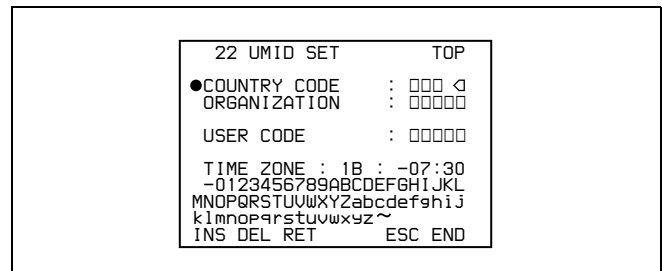

Enter an abbreviated alphanumeric string (4-byte alphanumeric strings) according to the values defined in ISO 3166-1.

There are about 240 country codes.

Find your own country code on the following home page.

Refer to ISO-3166-1:

http://www.din.de/gremien/nas/nabd/iso3166ma/codlstp1/en_listp1.html

When the country code is less than 4 bytes, the active part of the code will occupy the first part of the 4-bytes and the remainder must be filled with the space character (20h).

Example: In the case of Japan

For Japan, if the country code is JP, it is 2 bytes, if JPN, it is 3 bytes.

Thus, enter the following:

JP_ _

or
 JPN _
 where _ represents a space.

ORGANIZATION (organization code)

When you select this item, the ORGANIZATION window appears.

(Refer to the COUNTRY CODE window above.)

Enter an abbreviated 4-byte alphanumeric string for the organization code.

Note

There are no problems in recording or playing back audio-video signals, if ORGANIZATION is not set.

Organization codes must be acquired by applying to the SMPTE registration office. When no organization code has been acquired, it is forbidden to enter an arbitrary string. As a rule, the code "00" must be entered. Freelance operators who do not belong to an origination should enter "~".

USER CODE

When you select this item, the USER CODE window appears.

(Refer to the COUNTRY CODE window above.)

Enter the 4-byte alphanumeric strings for user identification.

The user code is registered with each organization locally. It is usually not centrally registered.

When the user code is less than 4 bytes, enter the user code from the beginning of the 4 bytes and enter the space character (20h) in the remaining strings.

This user code is determined by the organization. The methods used depend on the organization.

Note

User bits cannot be entered when no organization code has been entered.

TIME ZONE

When you select this item, the TIME ZONE window appears.

The UTC is calculated based on the local time, using the time zone. If the time zone is not set, the UTC is not recorded correctly.

TIME ZONE	ESC
00. UTC	GREENWICH
01. UTC-01:00	AZORES
02. UTC-02:00	M-ATLANTIC
03. UTC-03:00	ARZENTINE
04. UTC-04:00	HALIFAX
05. UTC-05:00	NEW YORK
06. UTC-06:00	CHICAGO
07. UTC-07:00	DENVER
→08. UTC-08:00	LOSANGELES
09. UTC-09:00	ALASKA

Set the time difference from UTC. When setting the summer time or daylight savings time, change the code to one which will advance the time by 1 hour.

Note

When you change the time zone, adjust the built-in clock to local time and turn the power of the camcorder off and then the power on again.

7-3-11 Making Network Settings

The NETWORK page of the MAINTENANCE menu allows you to make settings for connections to other DV devices via a network.

Enabling automatic acquisition of the IP address

When the unit is shipped from the factory, automatic acquisition of the IP address is disabled. Proceed as follows to enable it.

- 1 Holding down the MENU knob, set the menu switch from OFF to ON.

The TOP menu appears.

- 2 Turn the MENU knob to move the ▶ mark to "MAINTENANCE", and press the MENU knob.

If this is the first time the MAINTENANCE menu has been displayed, the CONTENTS page appears.

If the menu has been used before, the last accessed page appears.

- 3 If the CONTENTS page is displayed, turn the MENU knob to move the ▶ mark to "NETWORK", and press the MENU knob.

If a different page is displayed, turn the MENU knob until the NETWORK page appears, then press the MENU knob.

The NETWORK page appears. The current settings of the items on the page appear to the right of the items.

M18ONETWORK	TOP
→DHCP	: DISABL
IP ADDRESS	: 192 168 1 10
SUBNET MASK	: 255 255 255 0
DEF. GATEWAT	: 0 0 0 0
LINK SPEED	: AUTO
DUPLEX	: AUTO

- 4 Press the MENU knob, and turn it to move the ▶ mark to "DHCP", then press the MENU knob.

The ▶ mark to the left of "DHCP" changes to a ● mark, and the ● mark to the left of the setting changes to a ? mark.

- 5 Turn the MENU knob to display “ENABL”, then press the MENU knob.

The ● mark changes to a ➔ mark and the ? mark changes to a ● mark.

- 6 To end the menu operation, set the MENU ON/OFF switch to OFF.

Note

Before enabling automatic acquisition of the IP address, check to be sure that this unit is connected to a network with a network cable.

The acquired IP address is displayed in the “IP ADDRESS” line of the NETWORK page. If an IP address could not be acquired, “0.0.0.0” is displayed. In this case, contact your network administrator.

Setting the IP address, subnet mask, and default gateway

The unit is shipped from the factory with the following settings.

IP ADDRESS: 192.168. 1.10
SUBNET MASK: 255.255.255. 0
DEF. GATEWAY: 0. 0. 0. 0

Proceed as follows to change the settings.

- 1 Carry out steps 1 to 3 in “Enabling automatic acquisition of the IP address” (page 128) to display the NETWORK page of the MAINTENANCE menu.
- 2 Turn the MENU knob to move the ➔ mark to “IP ADDRESS”, then press the MENU knob.

The IP ADDRESS setting window appears.

- 3 Move the ➔ mark to the value that you want to change, then press the MENU knob.

The ➔ mark changes to a ? mark.

- 4 Turn the MENU knob to display the desired value, then press the MENU knob.

The ? mark changes to a ➔ mark.

To cancel the change and restore the standard setting

Push the CANCEL/PRST/ESCAPE switch to the CANCEL/PRST side.

For details, see 7-1-3 “Basic Menu Operations” (page 101).

- 5 Repeat steps 3 and 4 to set the remaining values.

- 6 When you are finished, move the ➔ mark to SET, then press the MENU knob.

- 7 Turn the MENU knob to move the ➔ mark to “SUBNET MASK”, then press the MENU knob.

SUBNET MASK setting window appears.

- 8 Carry out steps 3 to 6 to set the subnet mask.

- 9 Turn the MENU knob to move the ➔ mark to “DEF. GATEWAY”, then press the MENU knob.

The DEF. GATEWAY setting window appears.

- 10 Repeat steps 3 to 6 to set the default gateway.

- 11 To end the menu operation, set the MENU ON/OFF switch to OFF.

Setting the communications speed

Set the communications speed by choosing AUTO, 10Mbps, or 100Mbps from the menu. The factory default setting is “AUTO”.

Proceed as follows.

- 1 Carry out steps 1 to 3 in “Enabling automatic acquisition of the IP address” (page 128) to display the NETWORK page of the MAINTENANCE menu.
- 2 Turn the MENU knob to move the ➔ mark to “LINK SPEED”, then press the MENU knob.
- 3 Turn the MENU knob to move the ➔ mark to the desired value, then press the MENU knob.
- 4 To end the menu operation, set the MENU ON/OFF switch to OFF.

Setting the communications mode (full duplex or half duplex)

Set the communications speed by choosing AUTO, FULL (full duplex) or HALF (half duplex) from the menu. The factory default setting is “AUTO”.

Proceed as follows.

- 1 Carry out steps 1 to 3 in “Enabling automatic acquisition of the IP address” (page 128) to display the NETWORK page of the MAINTENANCE menu.
- 2 Turn the MENU knob to move the ➔ mark to “DUPLEX”, then press the MENU knob.
- 3 Turn the MENU knob to move the ➔ mark to the desired mode, then press the MENU knob.

- 4 To end the menu operation, set the MENU ON/OFF switch to OFF.

7-4 Resetting USER Menu Settings to the Standard Settings

You can return all settings in the USER menu to the standard settings. It is also possible to change the standard settings from their factory default values.

For details on how to change the factory settings, refer to the Maintenance Manual.

Proceed as follows.

- 1 Set the MENU ON/OFF switch to ON.

The last accessed menu appears on the screen.

- 2 Turn the MENU knob until the USER FILE page appears, and press the MENU knob.

The USER FILE page appears.

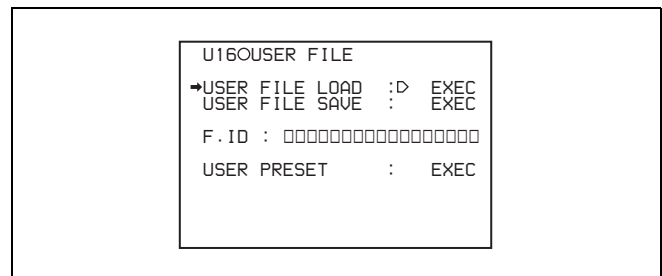

USER FILE page

- 3 Turn the MENU knob to move the ➔ mark to “USER PRESET”, and press the MENU knob.

The message “LOAD OK? YES ➔ NO” appears.

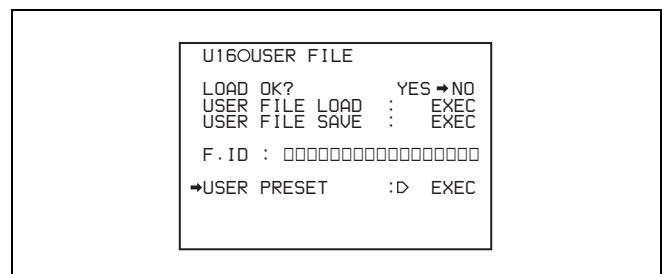

- 4 Turn the MENU knob to move the ➔ mark to “YES”, and press the MENU knob.

The settings for all items in the USER menu are reset to the standard settings.

Saving and Loading User Setting Data

Chapter

8

8-1 Saving and Loading User Files to and from a “Memory Stick”

The camcorder is equipped with a “Memory Stick” drive, which enables you to save user files, scene files, lens files, reference files and “ALL” files. You can load these files from the “Memory Stick” for immediate recall of a particular setting configuration.

When a menu is displayed, you can set up the camcorder so that inserting a “Memory Stick” automatically jumps to the appropriate file-related menu page.

For details about scene files, see 8-2 “Saving and Loading Scene Files” on page 136.

For details about lens files, reference files and “ALL” files, refer to the Maintenance Manual.

For details of the function for jumping to the appropriate file-related menu page, see 8-3 “Jumping to a File-Related Menu Page When Inserting a “Memory Stick”” on page 140.

“Memory Sticks” usable with this camcorder

With this camcorder, you can use “Memory Sticks” whose capacity does not exceed 128 MB.

For details, see “Memory Stick” in the Specifications on page 167.

8-1-1 Handling the “Memory Stick”

The “Memory Stick” can be inserted to or removed from the camcorder with the power turned on or off.

Inserting the “Memory Stick”

Proceed as follows.

- 1** Open the cover of the menu operating section.

The “Memory Stick” slot is now visible.

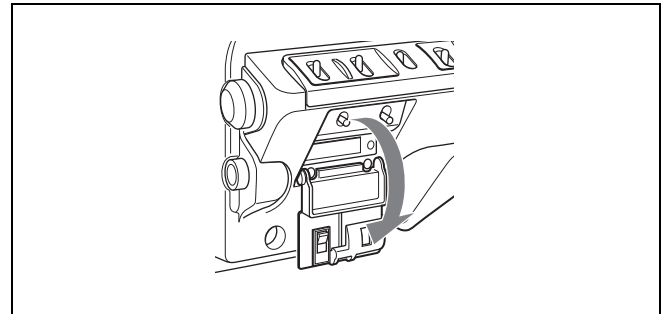

- 2** Hold the “Memory Stick” with the notch facing downward and the arrow facing away from you, and insert the “Memory Stick” into the “Memory Stick” slot until it clicks into place. Then close the cover.

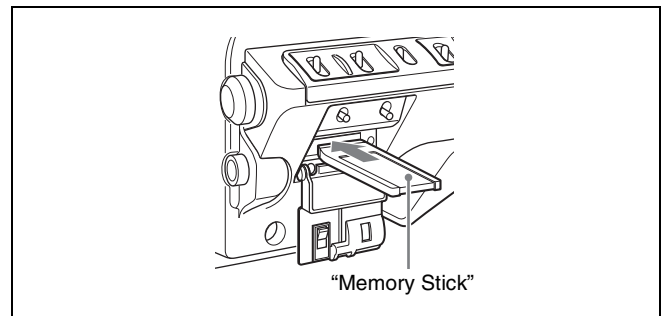

Inserting the “Memory Stick”

Note

If it does not fit into the slot properly or if there is some resistance when you insert it, the “Memory Stick” may be turned around or upside down. Do not force the “Memory Stick” into the slot. Confirm the direction of the notch and arrow on the “Memory Stick” before inserting the “Memory Stick”, and then try inserting it again.

Removing the “Memory Stick”

Check that the access indicator is not lit, then gently press in the “Memory Stick” and release. It pops out, and you can withdraw it from the slot.

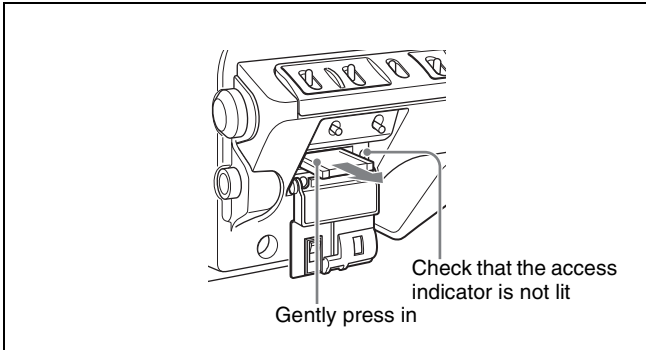

Removing the “Memory Stick”

Note

Do not remove the “Memory Stick” while the access indicator is lit. You may lose data, or damage the “Memory Stick”.

Protecting saved data

To prevent accidental erasure of important setup data, use the LOCK switch on the “Memory Stick”.

Slide the switch right to the write protect position. It is now impossible to write or delete data on the “Memory Stick”.

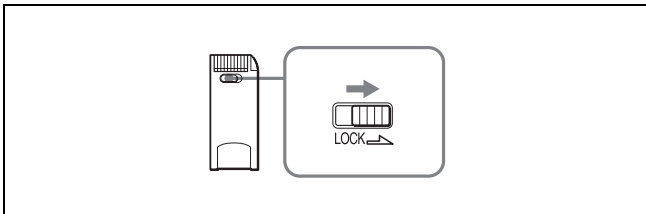

LOCK switch on the “Memory Stick”

Notes on using and storing the “Memory Stick”

- Avoid touching the connector of the “Memory Stick” or contacting it with a metal object.
- When attaching a label to the “Memory Stick”, use only the label supplied for the “Memory Stick”.
- Do not drop, bend, or submit the “Memory Stick” to external shock.
- Do not disassemble or modify the “Memory Stick”.

- Avoid getting liquids on the “Memory Stick”.
- Avoid using or storing the “Memory Stick” in a location subject to:
 - extremely high temperature such as the hot inside of a car or the outdoors exposed to a burning sun, or a place near a heater.
 - direct sunlight
 - high humidity
 - excessive dust
- When storing and carrying the “Memory Stick”, keep it in its original case to ensure protection of important data.
- When carrying the camcorder with the “Memory Stick” inserted, close the cover of the menu operating section.
- Avoid removing the “Memory Stick” from the insertion slot while the access indicator is lit.
- Do not format the “Memory Stick” using a PC. For formatting the “Memory Stick”, see the description of the MEMORY STICK page of the FILE menu on page 190.

8-1-2 Saving User Menu Data to the “Memory Stick”

You can save USER menu settings held in the camcorder as user files in the “Memory Stick”.

You can save up to 100 user files in the “Memory Stick”. Insert the “Memory Stick”, then proceed as follows.

- 1 Set the MENU ON/OFF switch to ON.

The last accessed menu page appears on the screen.

- 2 Turn the MENU knob until the USER FILE page appears, then press the MENU knob to select the page.

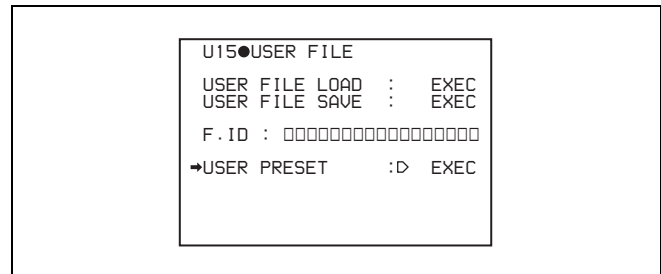

If you want to set a file ID for the data to be saved
Set the file ID before going to step 3.

For details on setting the file ID, see “Setting the file ID” on page 133.

- 3 Turn the MENU knob to move the ► mark to USER FILE SAVE, and press the MENU knob.

The P00 USER SAVE page appears.

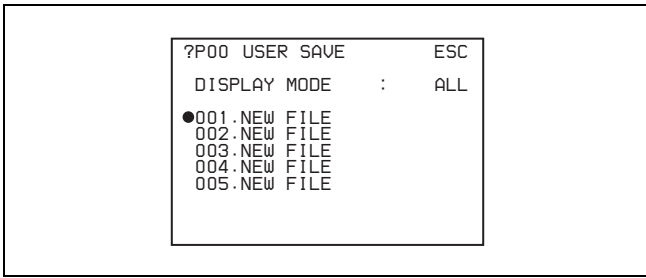

When a ? appears on the left of “P00” at the top left of the page, you can change the page. Up to 20 pages, from P00 to P19, can be used to save user files in the “Memory Stick”. Each page can hold up to 5 files.

- Turn the MENU knob until the page which contains the desired file number appears, and press the MENU knob.

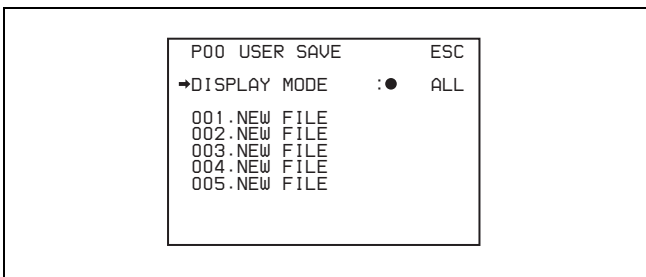

- Turn the MENU knob to move the → mark to the desired file number, and press the MENU knob.

The message “SAVE OK? YES → NO” appears.

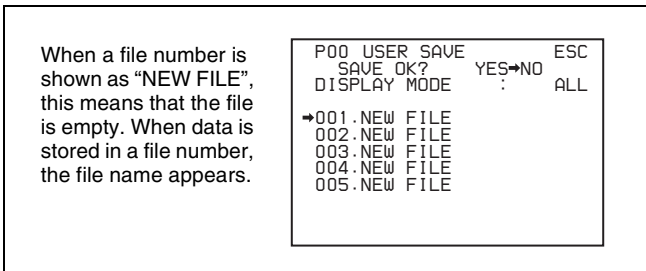

- To carry out the save, move the → mark to “YES” and press the MENU knob. To cancel, press the MENU knob leaving the → mark pointing to “NO”.

The access indicator lights.

When the saving is completed, the message “COMPLETE” appears and the access indicator goes off.

If no “Memory Stick” has been inserted, the message “NO MEMORY STICK” will appear. Insert a “Memory Stick”.

If you select a file number where data has already been saved

The message “OVERWRITE OK? YES → NO” appears. In this case, the → mark appears on the left of “NO”, which is flashing.

- To stop overwriting, press the MENU knob.
- To overwrite, move the → mark to “YES” and press the MENU knob.

You can select the information displayed on each USER SAVE or USER LOAD page.

For details, see “Selecting the display contents” on page 134.

- To end the menu operation, set the MENU ON/OFF switch to OFF or close the cover of the menu operating section.

The menu disappears from the viewfinder screen, and the display indicating the current status of the camcorder appears along the top and bottom of the screen.

USER menu settings to be saved in the “Memory Stick”

Settings for items on all pages of the USER menu are saved in the “Memory Stick” as a user file. However, you can select the items which are not to be saved in the “Memory Stick”.

For details, refer to the Maintenance Manual.

If data cannot be saved

If one of the following error messages appears during or after the save operation, then the data was not saved.

Data save error messages

Error message	Cause	Action
NO MEMORY STICK (flashing)	No “Memory Stick” is inserted.	Insert or reinsert the “Memory Stick”.
MEMORY STICK LOCKED	The LOCK switch on the “Memory Stick” is set to the write protect position.	Set the LOCK switch to the write enable position.
MEMORY STICK ERROR (flashing)	Circuit or “Memory Stick” fault.	Check the circuitry, or replace the “Memory Stick”.

Setting the file ID

Before data is saved to a “Memory Stick”, it is useful to set a file ID for the “Memory Stick” to identify it.

When data is saved to a “Memory Stick”, the file ID is saved to the “Memory Stick” together with the data.

Note

Set the file ID before saving data in the “Memory Stick”. Otherwise, the file ID is not saved with the other data.

Proceed as follows.

- 1 On the USER FILE page, turn the MENU knob to move the **➔** mark to “F. ID”.

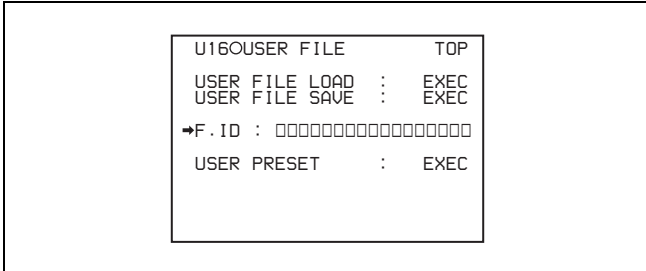

- 2 Press the MENU knob.

A character table appears, allowing you to select characters you want to enter.

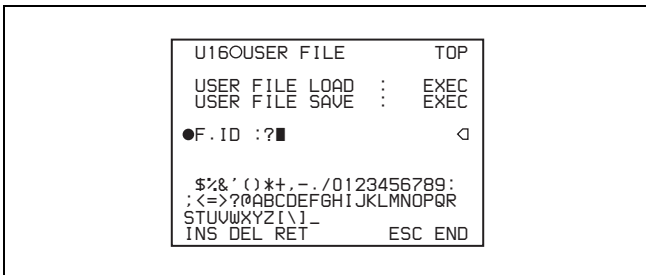

- 3 Follow the procedure of steps 4 and 5 described in 7-2-7 “Setting the Shot ID” on page 113 to enter the file ID.
- 4 When you finish entering the file ID, turn the MENU knob to move the **■** mark to “END”, then press the MENU knob.

The entered file ID is now displayed.

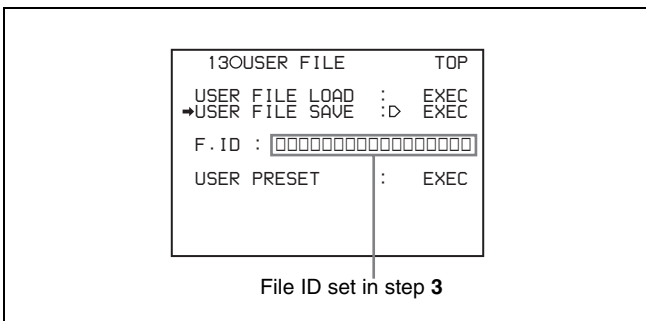

After setting the file ID, carry out the procedure from step 3 in 7-1-2 “Saving User Menu Data to the “Memory Stick”” on page 132.

The set file ID is saved in the “Memory Stick” with the data.

Selecting the display contents

You can select the contents of the file to be displayed on the USER SAVE page and USER LOAD page. Proceed as follows.

- 1 Turn the MENU knob to move the **➔** mark to “DISPLAY MODE”, and press the MENU knob.
- 2 Turn the MENU knob to move the **➔** mark until the desired type of the display contents (see the following table) appears, then press the MENU knob.

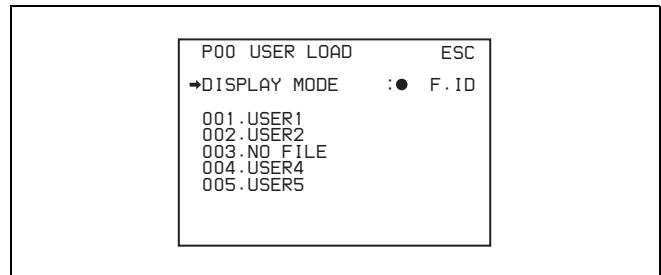

Display type	Description
ALL	File ID (10 characters) and date ((month/day/year) for PDW-510/530 and (day/month/year) for PDW-510P/530P)
F.ID	File ID (16 characters)
DATE	Saved date (year/month/day/hours/minutes/seconds)
MODEL	Information on the model

8-1-3 Loading saved data from a “Memory Stick”

Note

The data loaded from the “Memory Stick” overwrites the data saved in the camcorder.

Proceed as follows.

- 1 Set the MENU ON/OFF switch to ON.
The last accessed menu page appears on the screen.
- 2 Turn the MENU knob until the USER FILE page appears, then press the MENU knob. Alternatively, select “USER FILE” on the CONTENTS page.
- 3 Turn the MENU knob to move the **➔** mark to “USER FILE LOAD”, and press the MENU knob.

The P00 USER LOAD page appears.

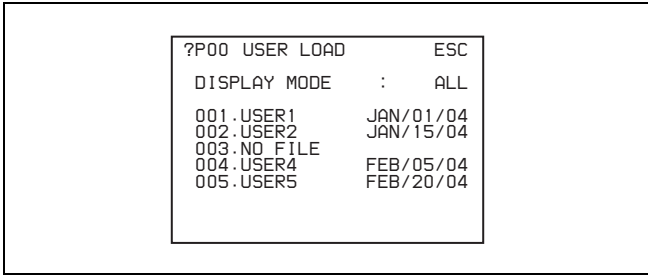

4 Turn the MENU knob until the page which contains the desired file number appears, then press the MENU knob.

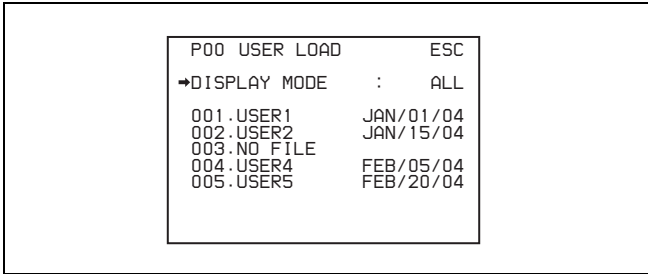

5 Turn the MENU knob to move the → mark to the desired file number to be loaded, and press the MENU knob.

The message “LOAD OK? YES → NO” appears.

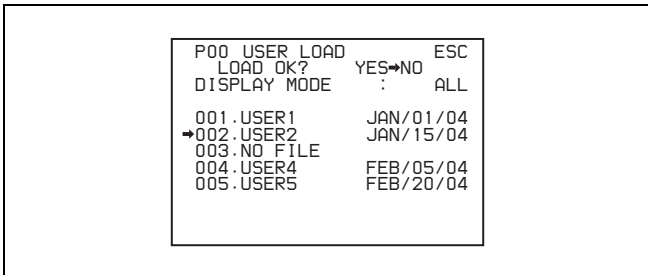

6 To carry out the load, move the → mark to “YES” and press the MENU knob.
To cancel, press the MENU knob leaving the → mark pointing to “NO”.

The access indicator lights.

When the load is completed, the message “COMPLETE” appears and the access indicator goes off.

The USER FILE page appears again.

7 To end the menu operation, set the MENU ON/OFF switch to OFF or close the cover of the menu operating section.

If data cannot be loaded

If one of the following error messages appears during or after the load operation, then the data was not loaded.

Data load error messages

Error message	Cause	Action
NO MEMORY STICK (flashing)	No “Memory Stick” is inserted.	Insert or reinsert the “Memory Stick”.
MEMORY STICK ERROR (flashing)	Circuit or “Memory Stick” fault.	Recheck, and consult your Sony representative.
FILE ERROR (flashing)	The “Memory Stick” contains data that cannot be loaded into this camcorder.	Do not try to load data saved from another camcorder.



8-2 Saving and Loading Scene Files

You can save various settings for shooting a particular scene as a scene file. Loading the scene file, you can quickly recreate setup conditions suitable for the scene. You can save up to five scene files in the camcorder memory and up to 100 scene files in a “Memory Stick”. You can also load data from the “Memory Stick” into the camcorder memory.

Data that can be saved in a scene file

You can save the following data in a scene file:

- Values adjusted using the PAINT menu

For details of the PAINT menu, refer to the Maintenance Manual.

- Shutter speed settings made in the standard mode and ECS mode
- The white balance data included in a scene file depends on the SCENE WHITE DATA setting on the REFERENCE page of the FILE menu.

For details, see “White balance setting data to be saved in the scene file” on page 137.

8-2-1 Saving a Scene File

Proceed as follows to save a scene file in the camcorder memory or the “Memory Stick”.

To save a scene file in the “Memory Stick”, insert the “Memory Stick” before starting the operation.

- 1 In the TOP menu, select the FILE menu.
- 2 Turn the MENU knob until the SCENE FILE page appears, then press the MENU knob to select the page. Alternatively, select “SCENE FILE” on the CONTENTS page to display the SCENE FILE page.

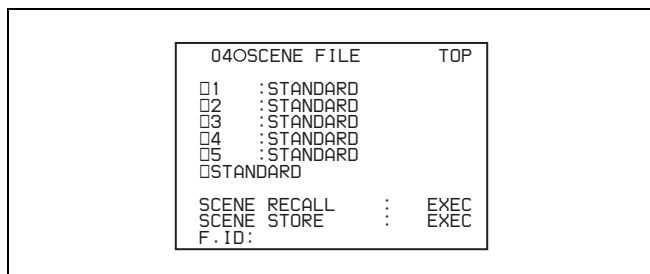

If you want to set a file ID for the data to be saved
Set the file ID before going to step 3.

For details on setting the file ID, see “Setting the file ID” on page 138.

- 3 Turn the MENU knob to move the ► mark to “SCENE STORE”, and press the MENU knob.

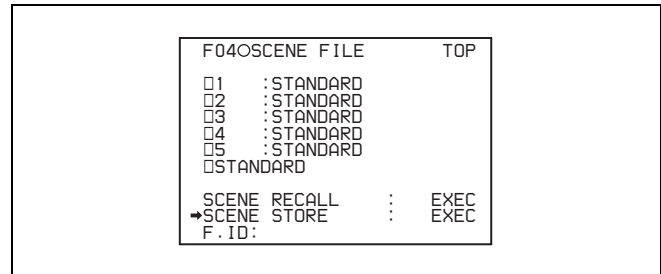

The SCENE STORE page appears.

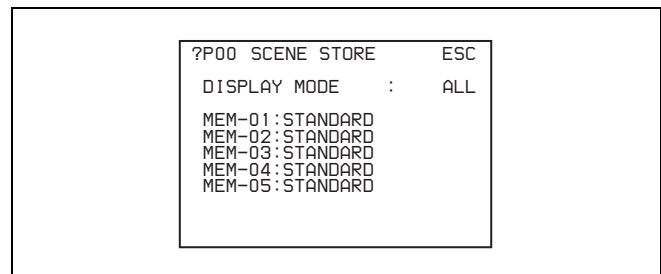

- 4 Select the desired file number.

When no “Memory Stick” has been inserted

Turn the MENU knob to move the ► mark to the desired file number, and press the MENU knob. When the save is completed, the SCENE FILE page appears again.

When you select a file number where data has already been saved

The message “OVERWRITE OK? YES ► NO” appears. In this case, the ► mark is placed on the left of “NO”.

- To stop overwriting, press the MENU knob.
- To overwrite, move the ► mark to “YES” and press the MENU knob.

When a “Memory Stick” has been inserted

You can use up to 20 pages, from P01 to P20, to save scene files in the “Memory Stick”. Each page can hold up to 5 files.

- ① Turn the MENU knob until the page which contains the desired file number appears, then press the MENU knob.

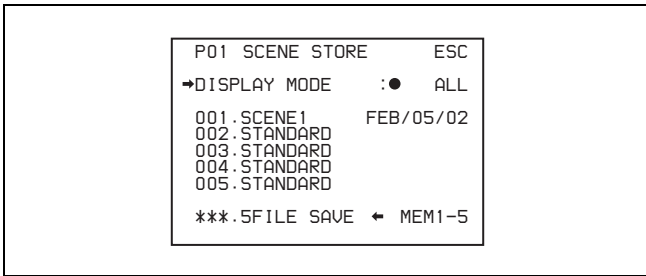

- ② Turn the MENU knob to move the ➔ mark to the desired file number, and press the MENU knob. The message “STORE OK? YES ➔ NO” appears.

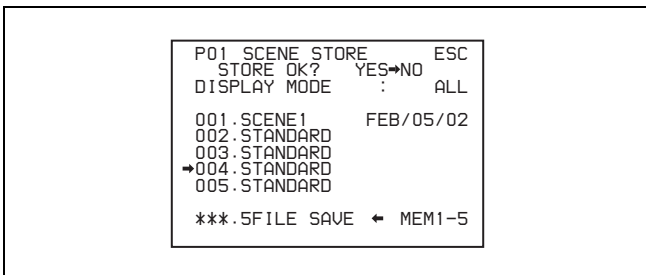

- ③ To carry out the storing, move the ➔ mark to “YES” and press the MENU knob. To cancel, press the MENU knob leaving the ➔ mark pointing to “NO”.

You can select the contents of the user file to be displayed on the page.

For details, see “Selecting the display contents” on page 138.

- 5 To end the menu operation, set the MENU ON/OFF switch to OFF or close the cover of the menu operating section.

To return to the SCENE FILE page

After the message “COMPLETE” is displayed, move the ➔ mark to “ESC” at the top right of the page by turning the MENU knob, then press the MENU knob.

White balance setting data to be saved in the scene file

The white balance setting data to be saved in the scene file depends on the setting of the SCENE WHITE DATA item on the REFERENCE page of the FILE menu.

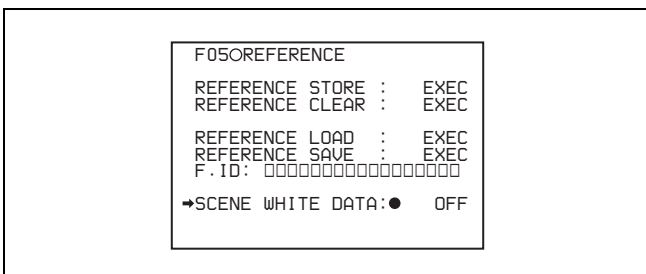

When SCENE WHITE DATA is set to ON

The white balance setting data selected when you save the scene file is saved. For example, when the WHITE BAL switch is set to A, the adjusted values in memory A are saved in the scene file, and when the WHITE BAL switch is set to PRST, the preset value is saved.

When SCENE WHITE DATA is set to OFF

White balance setting data is not stored in the scene file.

Saving scene files from the camcorder memory to the “Memory Stick”

You can save five scene files from the camcorder to the “Memory Stick” in a single operation.

Proceed as follows.

- 1 After displaying the SCENE FILE page (see page 136) turn the MENU knob to move the ➔ mark to “SCENE STORE”, then press the MENU knob.

One of the SCENE STORE pages appears.

- 2 Turn the MENU knob until the desired SCENE STORE page appears, then press the MENU knob.

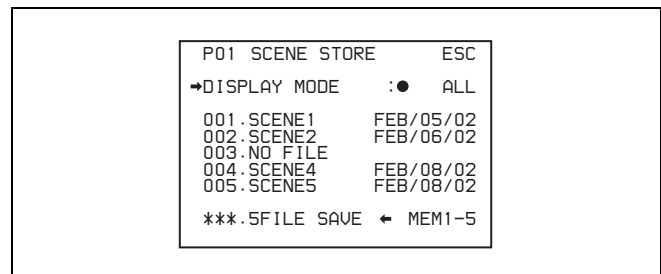

- 3 Turn the MENU knob to move the ➔ mark to “5FILE SAVE ← MEM1-5”, and press the MENU knob.

The message “SAVE OK? YES ➔ NO” appears.

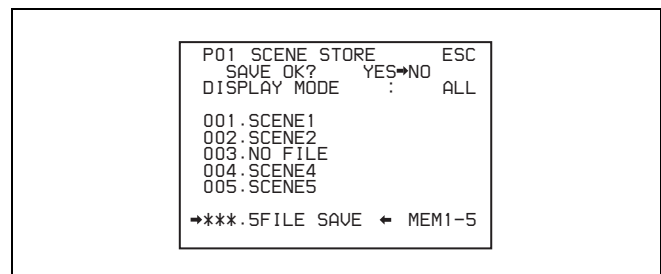

- 4 To carry out the save, move the ➔ mark to “YES” and press the MENU knob. To cancel, press the MENU knob leaving the ➔ mark pointing to “NO”.

When the save is completed, the message “COMPLETE” appears.

- 5 To end the menu operation, set the MENU ON/OFF switch to OFF.

Note

If files have been saved in the page selected in step 2, those files are replaced with files loaded from the camcorder memory. For example, files from 001 to 005 are replaced.

Setting the file ID

Before the data is saved as a scene file, it is useful to set a file ID to identify it. The set file ID is saved together with the data.

To set the file ID, proceed as follows.

- 1 On the SCENE FILE page, turn the MENU knob to move the \blacktriangleright mark to “F. ID”.

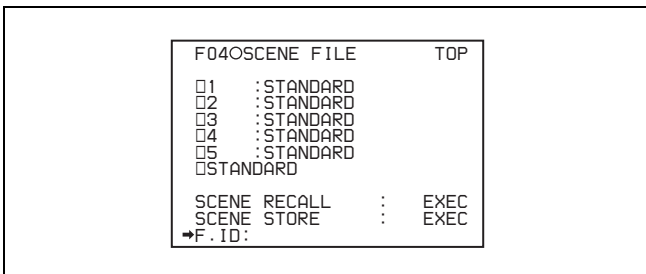

- 2 Press the MENU knob.

A character table appears, allowing you to select characters you want to enter.

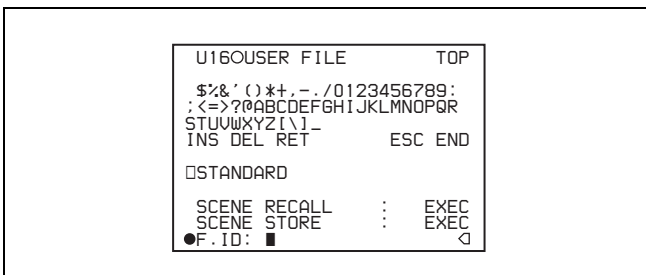

- 3 Carry out the operations for steps 4 and 5 described in 7-2-7 “Setting the Shot ID” on page 113 to enter the file ID.

Note

Set the file ID before saving the scene file in the “Memory Stick” or the camcorder memory. Otherwise, the file ID is not saved with the other data.

- 4 When you finish entering the file ID, turn the MENU knob to move the \blacksquare mark to “END”, then press the MENU knob.

The SCENE FILE page appears again.

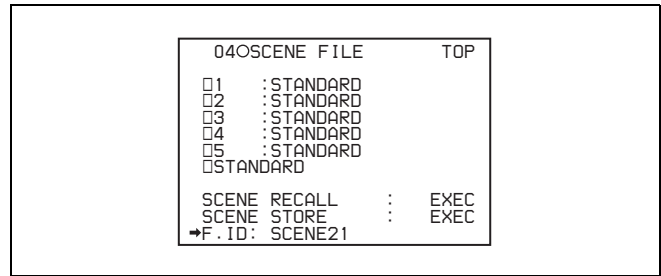

Carry out the procedure from step 3 in 8-2-1 “Saving a Scene File” on page 136.

The set file ID is saved together with the data.

Selecting the display contents

You can select the items of file information to be displayed on the SCENE STORE pages (P01 to P20) or the SCENE RECALL pages (P01 to P20) used for saving data to or loading data from a “Memory Stick”.

For details, “Selecting the display contents” on page 134.

8-2-2 Loading Scene Files

Proceed as follows.

- 1 In the TOP menu, select the FILE menu.
- 2 Turn the MENU knob until the SCENE FILE page appears, then press the MENU knob to select the page. Alternatively, on the CONTENTS page select “SCENE FILE”, and press the MENU knob to display the SCENE FILE page.
- 3 Load the scene file.

To load the scene file stored in the camcorder

Turn the MENU knob to move the \blacktriangleright mark to the desired file number, and press the MENU knob. The \square which is displayed on the left of the file number changes to \blacksquare . The camcorder is set up according to the loaded scene file.

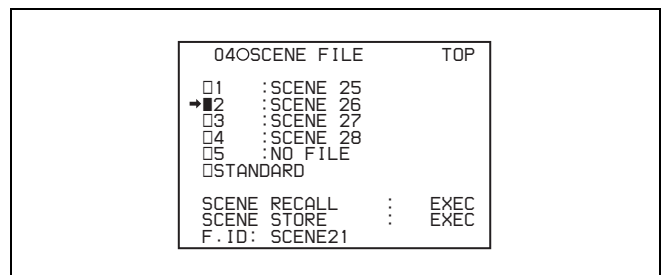
**To cancel the selected scene file**

Move the \blacktriangleright mark to \blacksquare , and press the MENU knob. \blacksquare changes to \square .

The camcorder returns to the settings before selecting this scene file.

To load a scene file saved in the “Memory Stick”

Proceed as follows.

- 1 Turn the MENU knob to move the **▶** mark to “SCENE RECALL”, and press the MENU knob.

The P00 SCENE RECALL page appears.

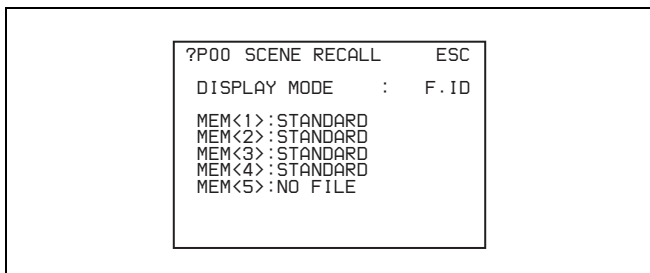

- 2 Turn the MENU knob until the page which contains the desired file number appears, then press the MENU knob.

- 3 Turn the MENU knob to move the **▶** mark to the desired file number, and press the MENU knob.

The message “RECALL OK? YES **▶**NO” appears.

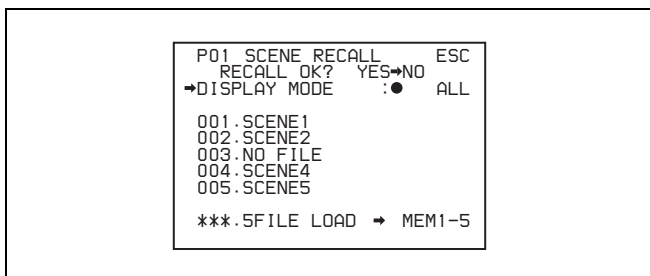

- 4 To carry out the recall, move the **▶** mark to “YES” and press the MENU knob. To cancel, press the MENU knob leaving the **▶** mark pointing to “NO”.

When the loading is completed, the message “COMPLETE” appears. The camcorder is set up according to the loaded scene file.

If no file is present with a particular file number, this is shown as “NO FILE”.

- 5 To end the menu operation, set the MENU ON/OFF switch to OFF or close the cover of the menu operating section.

Loading scene files from a “Memory Stick” into the camcorder memory

You can load up to five scene files stored in the “Memory Stick” into the camcorder memory in a single operation.

- 1 After displaying the SCENE FILE page (see page 138), turn the MENU knob to move the **▶** mark to “SCENE RECALL”, and press the MENU knob.

A SCENE RECALL page appears.

- 2 Turn the MENU knob until the SCENE RECALL page which contains the desired scene files appears, then press the MENU knob.

- 3 Turn the MENU knob to move the **▶** mark to “5FILE LOAD **▶** MEM 1-5”, and press the MENU knob.

The message “RECALL OK? YES **▶**NO” appears.

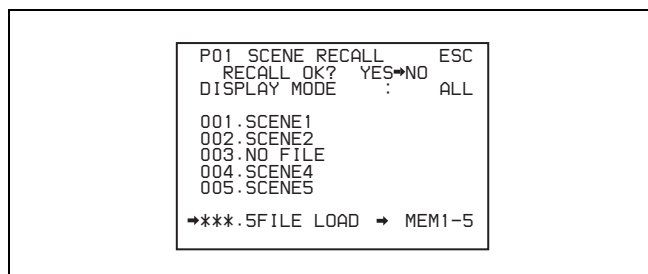

- 4 To carry out the recall, move the **▶** mark to “YES” and press the MENU knob. To cancel, press the MENU knob leaving the **▶** mark pointing to “NO”.

When loading is complete, the message “COMPLETE” appears and the access indicator goes off.

- 5 To end the menu operation, set the MENU ON/OFF switch to OFF or close the cover of the menu operating section.

Notes

- The scene files loaded from the “Memory Stick” overwrite data saved in the camcorder memory.
- To load the scene file saved in the camcorder memory when the “Memory Stick” is inserted, return to the P00 SCENE RECALL page and load the desired scene file in the camcorder memory.
- When there is no file to be loaded (shown as “NO FILE”), an existing file of the same number is unaffected. In the example shown in step 3, MEM(3) is not overwritten.

8-2-3 Resetting the Settings of the Camcorder to the Standard Settings Saved in the Reference File

You can reset the settings of the camcorder to the settings saved in the reference file (standard settings).

For details about the items in the reference file, refer to the Maintenance Manual.

On the SCENE FILE page (see page 138), turn the MENU knob to move the \blacktriangleright mark to “STANDARD”, and press the MENU knob.

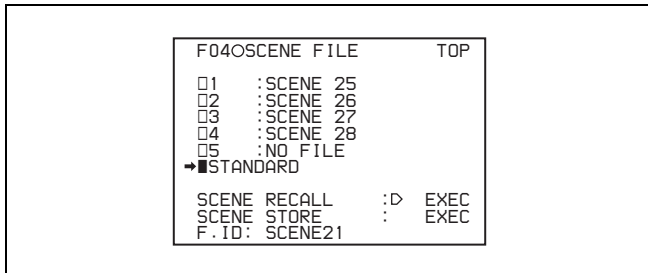

The \square displayed on the left of STANDARD changes to \blacksquare . When \blacksquare changes to \square , the settings of the camcorder are reset to the settings saved in the reference file.

If you press the MENU knob again while \blacksquare is displayed, the operation is cancelled and the camcorder returns to the settings before STANDARD was selected.

8-3 Jumping to a File-Related Menu Page When Inserting a “Memory Stick”

A “Memory Stick” enables you to save user files, scene files, lens files, reference files and “ALL” files. The camcorder menu system allows you to make a setting so that when a “Memory Stick” holding these files is inserted while in menu operating mode, a menu page relating to the desired file is automatically displayed on the screen. Thus you can proceed to file operation quickly. This is very convenient especially when you manage data files using “Memory Stick”s.

To make this setting, proceed as follows.

- 1 In the TOP menu, select the FILE menu.
- 2 Turn the MENU knob until the MEMORY STICK page of the FILE menu appears, then press the MENU knob to select the page. Alternatively, on the CONTENTS page select MEMORY STICK to display the MEMORY STICK page.

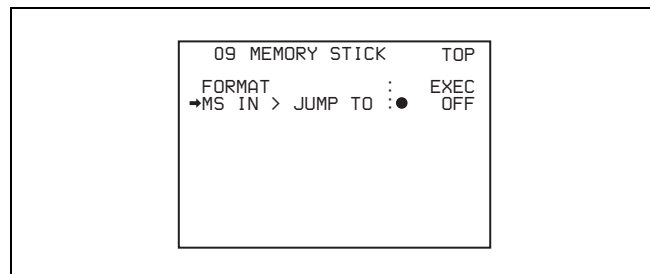

- 3 Turn the MENU knob to move the \blacktriangleright mark to “MS IN > JUMP TO”, and press the MENU knob.

The \blacktriangleright mark on the left of “MS IN > JUMP TO” changes to a \bullet mark and the \bullet mark on the left of the setting changes to a ? mark.

- 4 Turn the MENU knob to select the desired setting (target FILE menu page).

Setting	Description
OFF	Disables this function.
USER	Jumps to the USER FILE page.
ALL	Jumps to the ALL FILE page.
SCENE	Jumps to the SCENE FILE page.
LENS	Jumps to the LENS FILE 1 page.
REFER	Jumps to the REFERENCE page.

Setting	Description
USER 1	Jumps to the USER 1 page.

5 Press the MENU knob to confirm the selection.

The ● mark changes to a ➔ mark and the ? mark changes to a ● mark.

Notes

In the following cases, jumping to the target page is impossible.

- When the power is turned on after you insert a “Memory Stick”.
- When OFF is selected for the MS IN > JUMP TO item.
- When any of the following menu pages is already displayed.
 - A file-related page such as the USER FILE page of the FILE menu
 - MEMORY STICK, ALL FILE, SCENE FILE, LENS FILE, REFERENCE FILE or ROM VERSION page

Setting Up the Camcorder

Chapter

9

9-1 Power Supply

The following power supplies can be used with the camcorder.

- BP-GL65/GL95/L60S Lithium-ion Battery Pack
- BP-M100 Nickel Metal Hydride Rechargeable Battery Pack
- AC power using the AC-550/550CE or AC-DN10 AC adaptor

9-1-1 Using a Battery Pack

When a BP-GL95 Battery Pack is used, the camcorder will operate continuously for about 120 minutes. Before use, charge the battery pack with a BC-M150 Battery Charger. It takes about 145 minutes to charge one BP-GL95.

For details, refer to the battery charger operation manual.

When a BP-M100 Battery Pack is used, the camcorder will operate for about 120 minutes. Before use, charge the battery pack with a BC-M50 Battery Charger. It takes about 240 minutes to charge one BP-M100.

For details, refer to the battery charger operation manual.

Note on using the battery pack

A warm battery pack may not be able to be fully recharged.

Attaching the battery pack

- 1 Press the battery pack against the back of the camcorder, aligning the line on the side of the battery pack with the matching line on the camcorder.

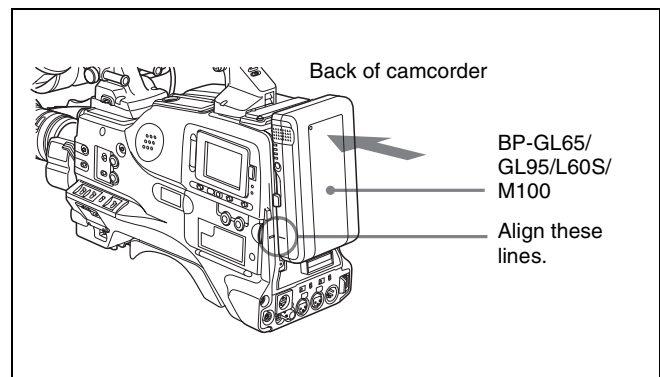

- 2 Slide the battery pack down until its "LOCK" arrow points at the matching line on the camcorder.

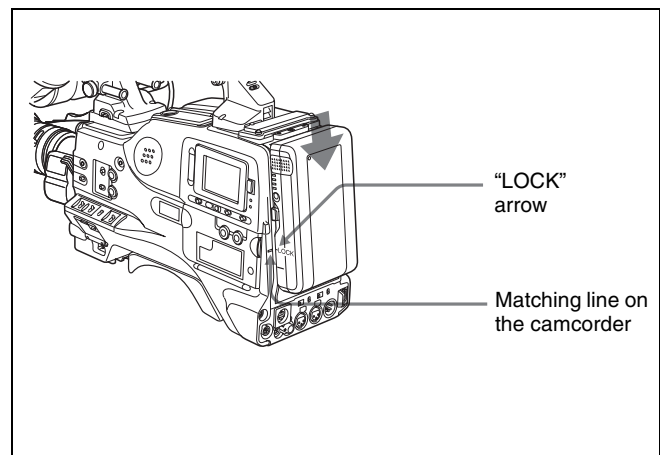

Detaching the battery pack

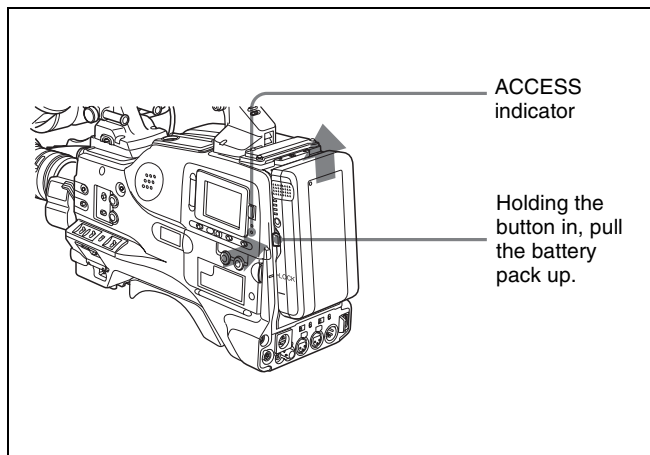

Detaching the battery pack

Note

During recording or playback (while the ACCESS indicator is lit), be careful never to remove the battery pack.

9-1-2 Avoiding Breaks in Operation Due to an exhausted Battery

When the battery pack is becoming exhausted, you can perform battery replacement without causing a break to the camcorder operation by using an AC adaptor.

To do this, proceed as follows.

- 1 Connect an AC-550/AC-550CE Adaptor to an AC power source, then connect it to the DC IN connector of the camcorder.

For details, see the next section.

The power source switches automatically from the battery pack to the AC adaptor connected to the DC IN connector.

Note

There may be some noise on the video signal at the time of power source switching.

- 2 Replace the battery pack with a fully charged one.

9-1-3 Using an AC Adaptor

Using the AC-550/550CE AC adaptor

Connect the camcorder to the AC power supply through the AC-550/550CE AC Adaptor as shown in the following figure, and turn the POWER switch of the AC-550/550CE on.

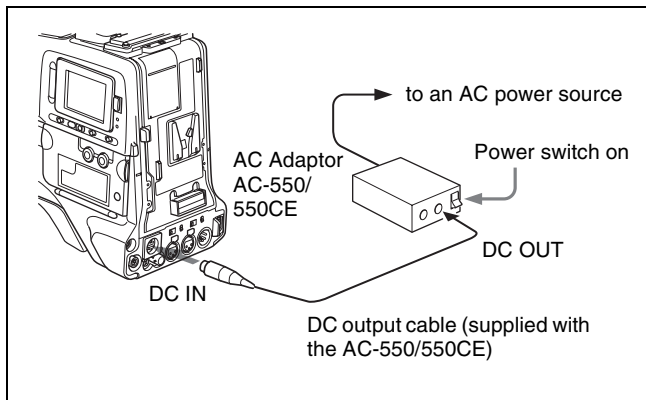

Using an AC adaptor

Using the AC-DN10 AC adaptor

Mount the AC-DN10 on the camcorder in the same way as a battery pack, then connect to the AC power supply. The AC-DN10 can supply up to 100 W of power.

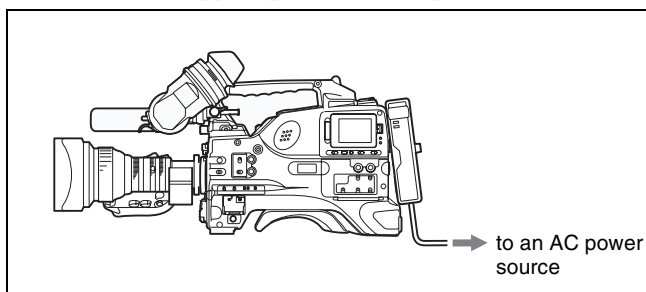

Connecting to an AC power source using the AC-DN10 AC Adaptor

9-1-4 Using the Anton Bauer Ultralight System

By fitting the camcorder with the Anton Bauer Ultralight system, and setting the LIGHT switch to AUTO, you can switch the light on and off automatically as you start and stop REC operation. This system operates with lights powered by 12 V, with a maximum power consumption of 50 W.

9-2 Adjusting the Viewfinder

For maximum viewing convenience, you can adjust the viewfinder position in the left-right and backward-forward directions.

9-2-1 Adjusting the Viewfinder Position

Adjusting the position to the left or right

Proceed as follows.

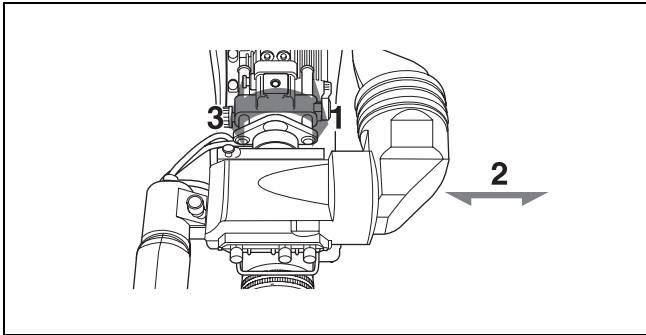

Adjusting the position to the left or right

- 1 Loosen the viewfinder left-right positioning ring.
- 2 Slide the viewfinder to the most convenient position.
- 3 Tighten the viewfinder left-right positioning ring.

To store the camcorder in the carrying case

Always store the camcorder with the viewfinder moved fully in the direction opposite to the barrel and the viewfinder left-right positioning ring tightened.

Adjusting the position backward or forward

Proceed as follows.

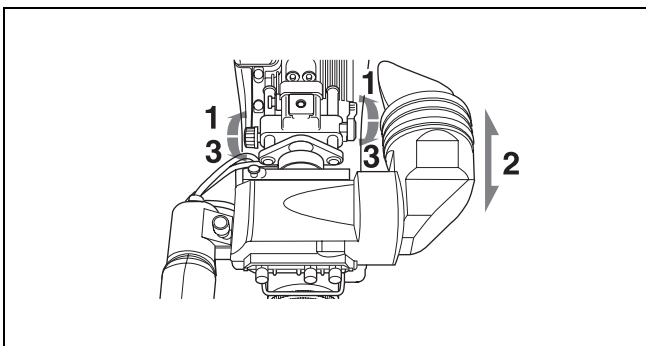

Adjusting the position backward or forward

- 1 Loosen the viewfinder front-rear positioning lever and the LOCK knob.
- 2 Slide the viewfinder longitudinally to the most convenient position.
- 3 Tighten the viewfinder front-rear positioning lever and the LOCK knob.

9-2-2 Adjusting the Viewfinder Focus and Screen

Adjusting the viewfinder focus

Turn the diopter adjustment ring until the viewfinder image is sharpest.

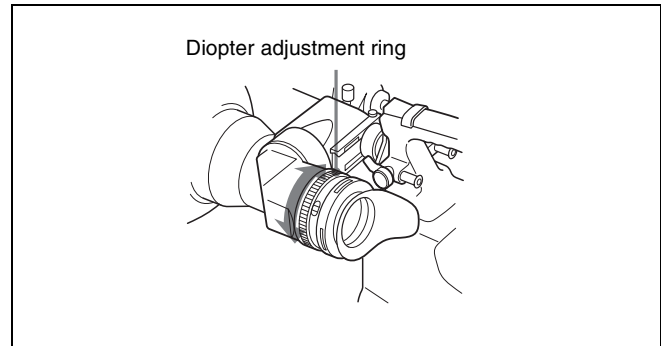

Adjusting the viewfinder focus

Adjusting the viewfinder screen

Adjust the brightness, contrast, and peaking of the viewfinder screen with the controls shown below.

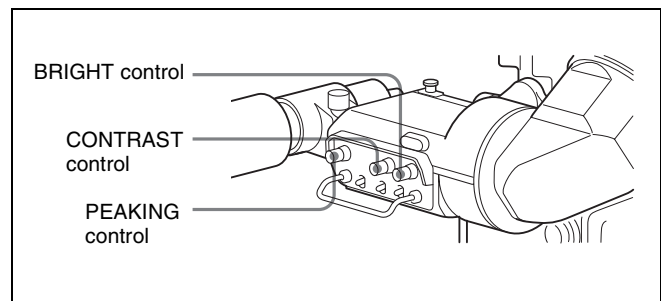

Adjusting the viewfinder screen

9-2-3 Detaching the Viewfinder

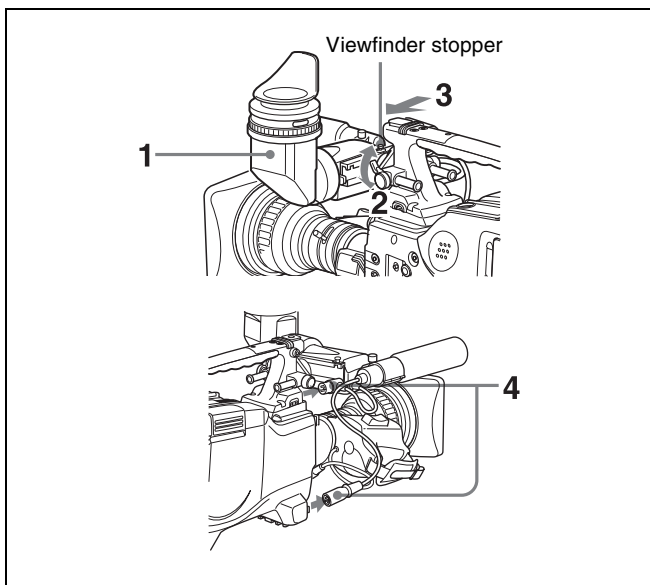

Detaching the viewfinder

- 1 Point the viewfinder barrel up or down.
- 2 Loosen the viewfinder left-right positioning ring.
- 3 Holding the viewfinder stopper up, slide the viewfinder in the direction indicated by the arrow and detach it.
- 4 Remove the viewfinder cable and microphone cable from the clamps and disconnect them.

9-2-4 Moving the viewfinder shoe up

- 1 Using a hexagonal wrench 2.5 mm across flats, remove the bolts (M3 × 25) and spring washers, to detach the viewfinder shoe from the camcorder body.

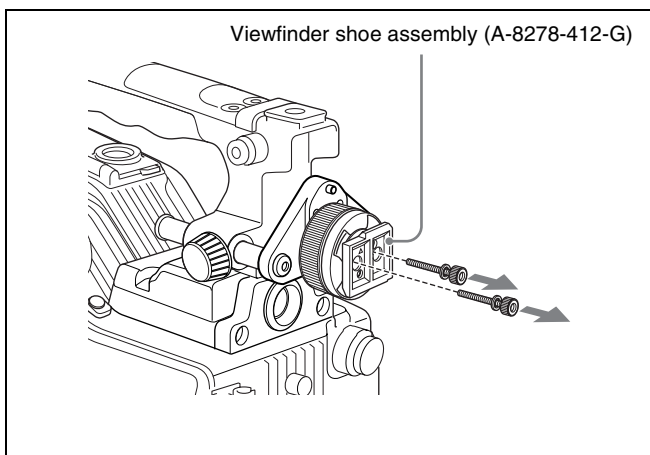

- 2 Fit two of the four holes in the back of the viewfinder shoe over the upper two pins on the fixing plate. Make sure that the triangular mark on the viewfinder shoe is pointing up.

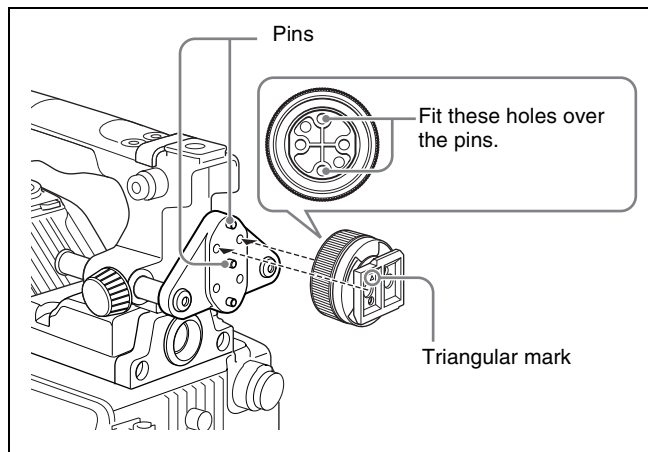

- 3 Using the bolts and spring washers removed in step 1, fix the viewfinder shoe to the camcorder.

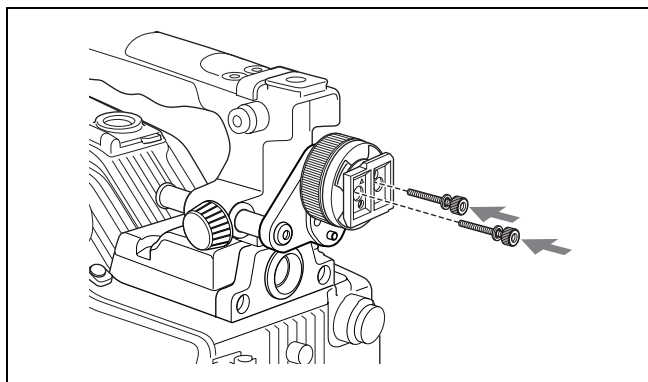

9-2-5 Using the BKW-401 Viewfinder Rotation Bracket

By fitting a BKW-401 Viewfinder Rotation Bracket (not supplied), you can rotate the viewfinder out of the way so that your right leg does not hit the viewfinder while you are carrying the camcorder.

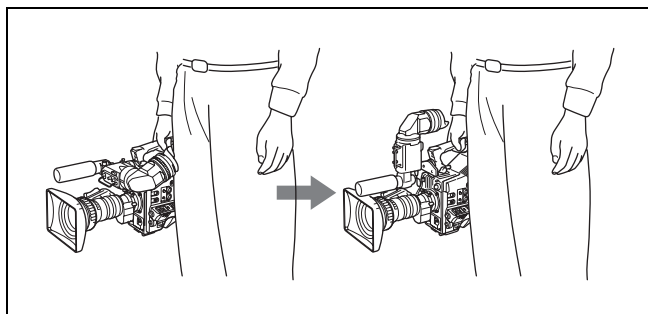

Using the BKW-401 Viewfinder Rotation Bracket

To fit the BKW-401 to the camcorder, proceed as follows.

- 1 Turn the arm of the rotation mechanism assembly of the BKW-401 in the direction of the arrow in the following illustration. Next, using a hexagonal wrench 3 mm across flats, remove the bolts (M4 × 8), to separate the rotation mechanism assembly from the viewfinder front-back positioning mechanism assembly.

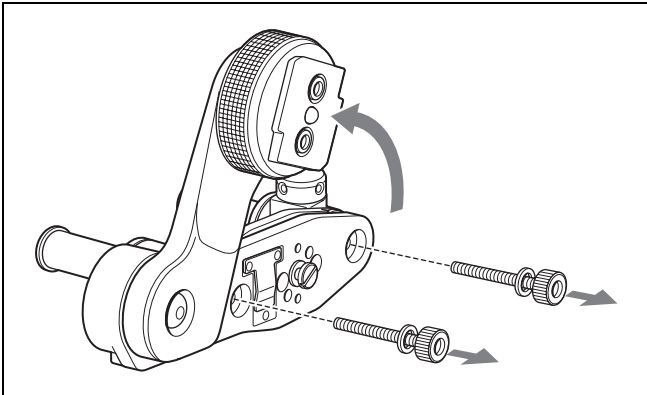

- 2 Remove the two M3 × 10 hexagon socket bolts from the front-back positioning mechanism assembly, together with the washers. Take care not to lose these bolts and washers.

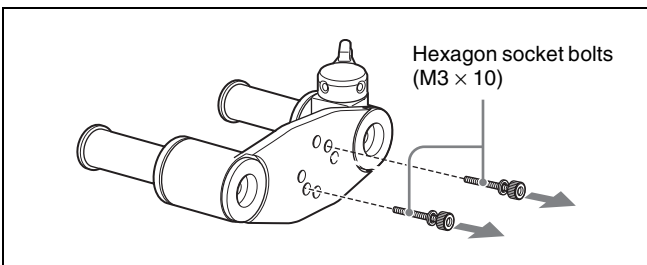

- 3 Using a hexagonal wrench 2.5 mm across flats, detach the viewfinder shoe from the camcorder body.

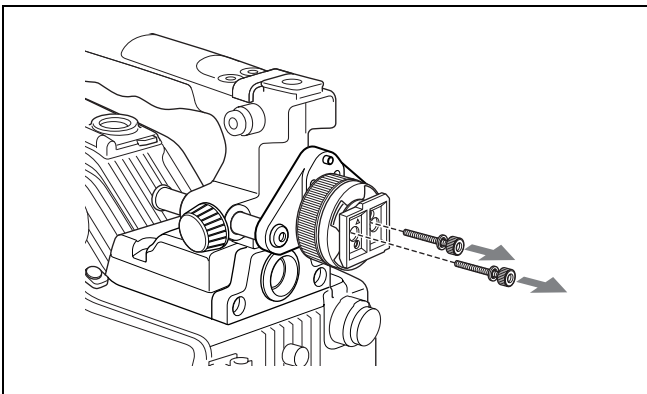

- 4 Using the two bolts (M3 × 10) and washers removed in step 2, attach the rotation mechanism assembly of the BKW-401 to the camcorder.

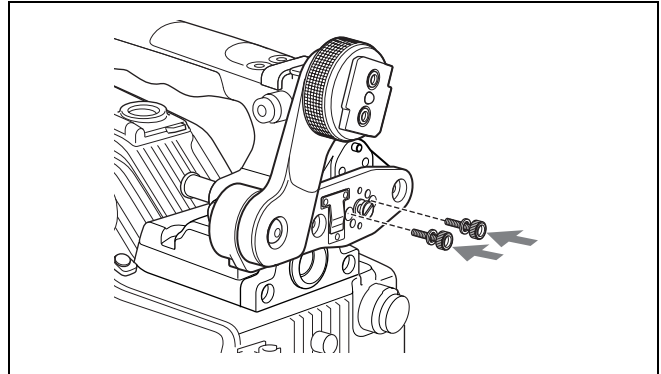

9-2-6 Detaching the Eyepiece

Removing the eyepiece gives a clearer view of the screen from further away. It is also easy to remove dust from the viewfinder screen and mirror when the eyepiece is detached.

- 1 Turn the eyepiece locking ring fully counterclockwise, to align the red marks on the locking ring and the viewfinder barrel.

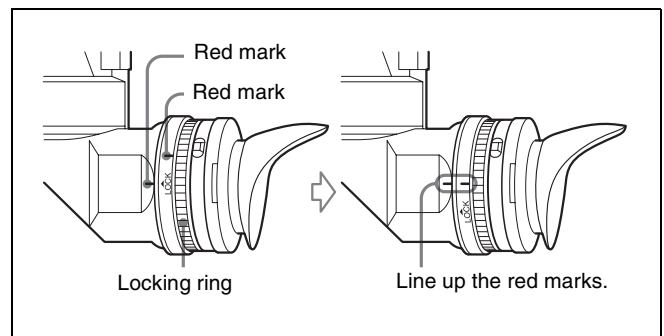

- 2 Detach the eyepiece.

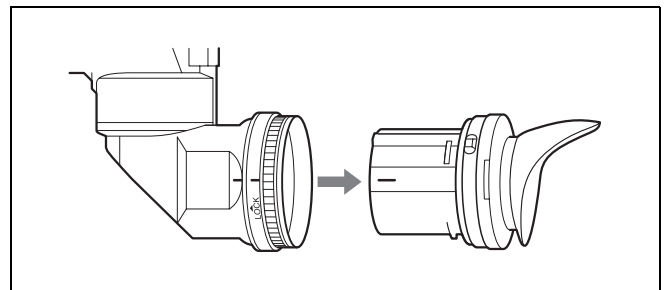

Reattaching the eyepiece

- 1 Align the red marks on the eyepiece locking ring and the viewfinder barrel.
- 2 Align the red mark on the end of the eyepiece end with the red marks on the eyepiece locking ring and the viewfinder barrel. Then insert the eyepiece into the viewfinder barrel.

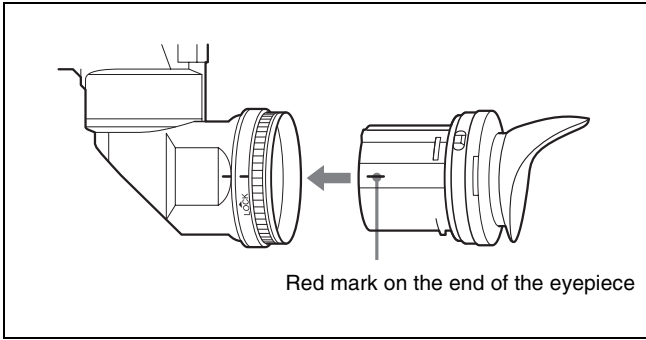

- 3** Turn the eyepiece locking ring clockwise until its “LOCK” arrow points at the red mark on the viewfinder barrel.

Note

When the eyecup is worn out, replace it with a new one (service part number 3-723-079-03). (The camcorder was shipped with an eyecup whose part number is 3-776-341-01.)

9-3 Mounting the Lens

To mount the lens, proceed as follows.

For information about using the lens, refer to the lens manual.

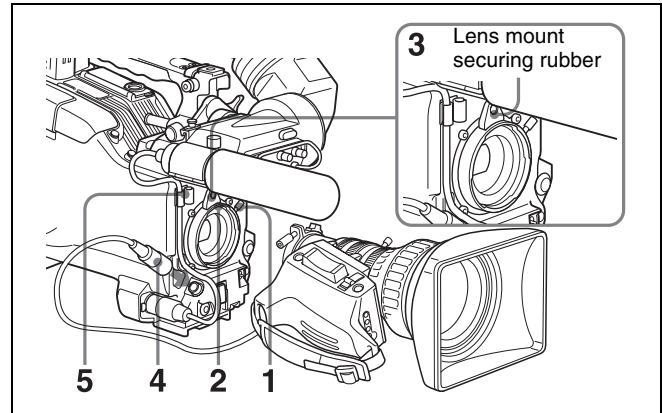

Mounting the lens

- 1** Push the lens locking lever up and remove the lens mount cap from the lens mount.
- 2** Align the center slot in the lens mount with the center pin on the lens, and insert the lens into the mount.
- 3** Holding the lens in place, push the lens locking lever down to mount the lens.

Note

If the lens is not firmly locked, it may come off while the camcorder is being used. This could cause a serious accident. Make sure the lens is firmly locked. It is recommended that the lens mount securing rubber be put on the lens-locking lever as illustrated above.

- 4** Connect the lens cable to the LENS connector.
- 5** Secure the lens cable with the cable clamps.

9-4 Adjusting the Flange Focal Length

If the lens does not stay in focus properly as you zoom from telephoto to wide angle, adjust the flange focal length (the distance from the plane of the lens mounting flange to the imaging plane). Make this adjustment after mounting or changing the lens.

Adjusting the flange focal length

The position of the controls for adjusting the flange focal length vary somewhat from lens to lens. Check the identification of the various controls in the lens manual.

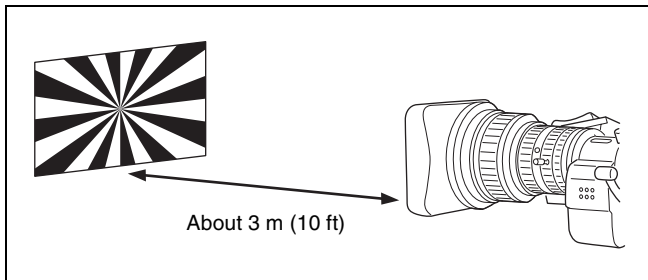

Adjusting the flange focal length

- 1 Set the iris to manual.
- 2 Open the iris. Place the flange focal length adjustment chart about 3 m (10 ft) away from the camera, lit well enough to provide a satisfactory video output level.
- 3 Loosen the fixing screws on the F.f or F.B ring (flange focal length adjustment ring).
- 4 Use manual or power zoom to set the lens to telephoto.
- 5 Point the camera at the chart by turning the focus ring and focus on it.
- 6 Set the zoom ring to wide angle.
- 7 Turn the F.f or F.B ring until the chart is in focus, being careful not to disturb the focus ring.
- 8 Repeat steps 4 to 7 until the chart stays in focus all the way from wide angle to telephoto.
- 9 Tighten the F.f or F.B ring fixing screws.

9-5 Audio Input System

9-5-1 Using the Supplied Microphone

You can use the supplied microphone either detached from or attached to the camcorder.

Using the microphone detached from the camcorder

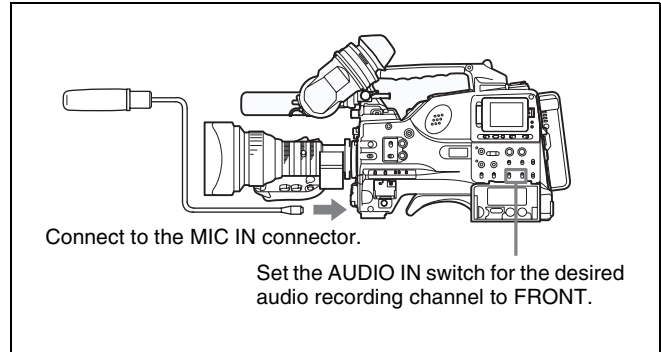

Using the microphone detached from the camcorder

Note

When using the supplied microphone with an extension cable, always use an external power supply type cable.

Using the microphone attached to the camcorder

- 1 Loosen the screw and open the microphone holder clamp.

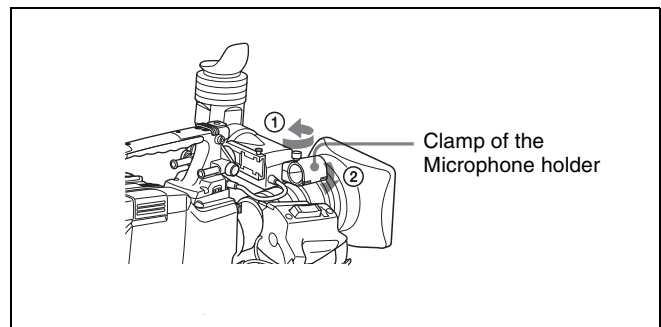

2 Place the microphone in the microphone holder.

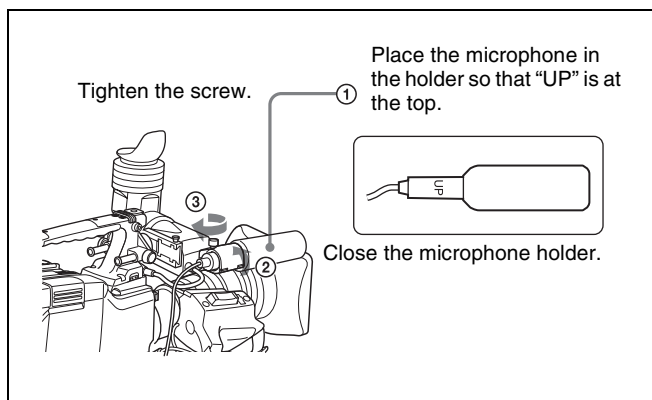

3 Plug the microphone cable into the MIC IN connector, then set the AUDIO IN switch for the desired recording channel to FRONT or F.

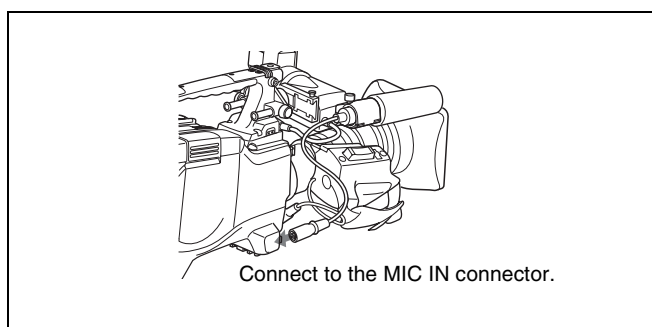

4 Secure the microphone cable with the cable clamp.

9-5-2 Using an External Microphone

You can connect up to two external monaural microphones using the AUDIO IN CH1 and CH2 connectors.

Switch settings when using an external microphone

When using an external microphone, make the following switch settings.

- Set the LINE / AES/EBU / MIC selector to MIC.
- Make the following setting, depending on the type of microphone used.

Using a microphone with an internal power supply:
set the +48V/OFF switch to OFF.

Using a microphone with an external power supply:
set the +48V/OFF switch to +48V.

- If the XLR connection automatic detection function (see next item) is off (the factory default setting), set the AUDIO IN CH-1/CH-2 switch for the channel to which the microphone is connected to "REAR".

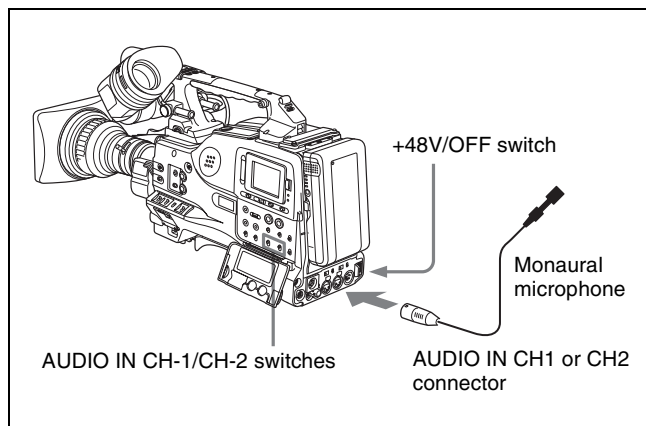

Using an external microphone (not attached to the camcorder)

XLR connection automatic detection function

With the XLR connection automatic detection function being on, when a cable is connected to the AUDIO IN CH1 or CH2 connector, the input from that connector is automatically selected for audio recording, regardless of the setting of the AUDIO IN CH-1 or CH-2 switch. The XLR connection automatic detection function can be switched on or off on the AUDIO-1 page of the MAINTENANCE menu, with the REAR XLR AUTO item.

Note

In order for the AUDIO IN CH1 and CH2 connectors on the camcorder to be able to provide a phantom 48 V power supply, female XLR connectors (3-pin) are fitted. If the microphone cable has a female connector, use an adaptor.

Using an external microphone attached to the camcorder

You can attach an external microphone to the camcorder.

- 1 Remove the fixing screws for external microphone holder.

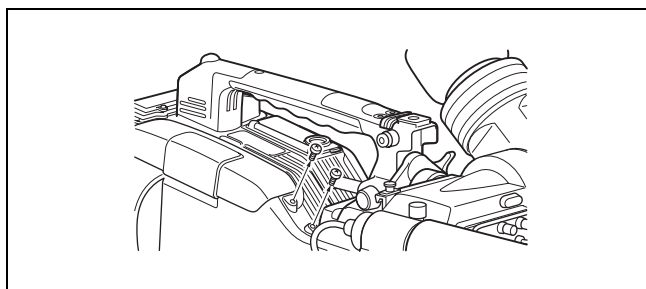

- 2 Attach the CAC-12 Microphone Holder.

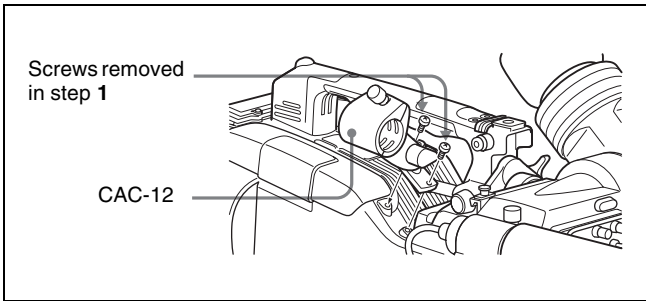

3 Open the CAC-12 and remove the microphone adaptor.

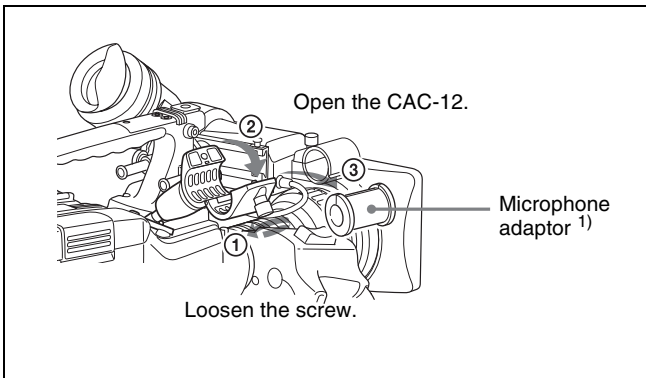

1) Attach the microphone adaptor when using a small-diameter external microphone.

4 Place an electret condenser microphone in the CAC-12.

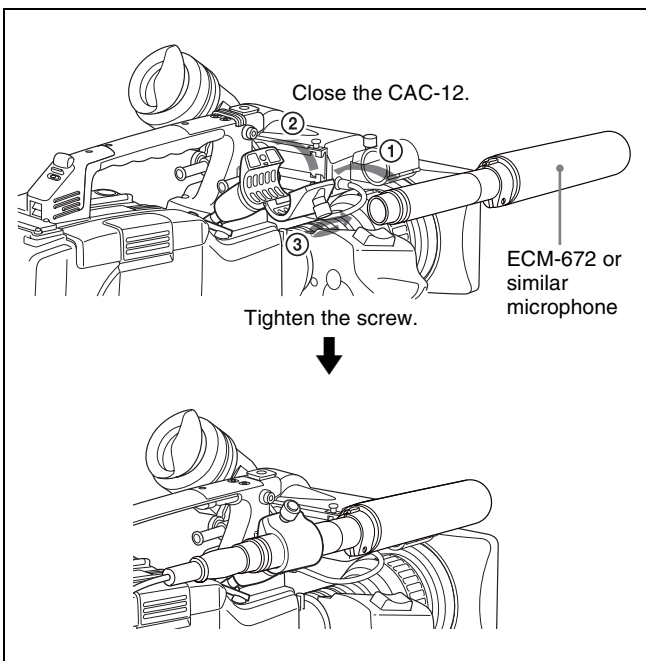

5 Connect the microphone cable to the AUDIO IN CH1 or AUDIO IN CH2 connector. Set the switches as described in the section “Switch settings when using an external microphone” (see page 149).

Note

When you detach the CAC-12 Microphone Holder once you have attached to the camcorder, be careful not to lose the two screws fixing the CAC-12. After detaching the CAC-12, be sure to put the two screws back into their original places (see the figure illustrating the step 1 operation).

9-5-3 Attaching a UHF Portable Tuner (for a UHF Wireless Microphone System)

To use a Sony UHF wireless microphone system, fit one of the following UHF portable tuners.

- WRR-855A/855B UHF Synthesized Tuner Unit
- WRR-862 UHF Portable Tuner.

For each of these UHF portable tuners, use the following attachment procedure.

For details, refer to the UHF portable tuner manual.

Fitting the WRR-855A/855B

You can use the WRR-855A/855B UHF Synthesized Tuner Unit simply by inserting it into the slot in the camcorder, and fastening the fixing screws.

1 Undo the four fixing screws holding the cover of the slot, and remove the cover.

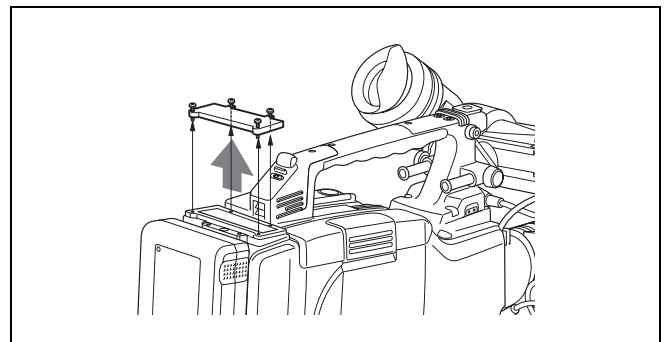

2 Insert the WRR-855A/855B, and fasten the four fixing screws.

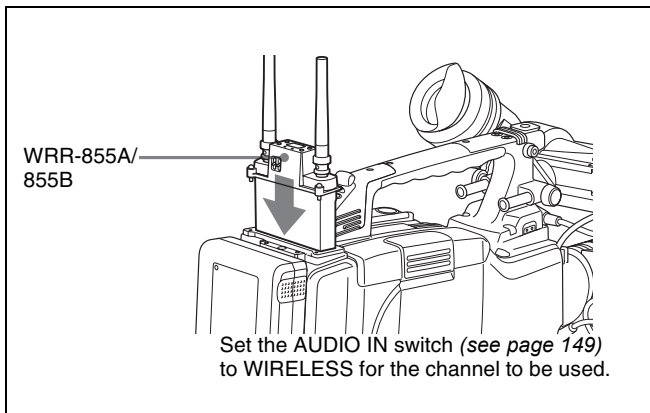

For the operation of the WRR-855A/855B, refer to the manual supplied with the WRR-855A/855B.

Notes

- When the XLR connection automatic detection function is on, even if the AUDIO IN CH-1 or CH-2 switch is set to WIRELESS, the signal input to the AUDIO IN CH1 or CH2 connector is automatically selected when an audio cable is connected to the AUDIO IN CH1 or CH2 connector. In such a case, set REAR XLR AUTO to OFF on the AUDIO-1 page of the MAINTENANCE menu.
- The audio signals to be recorded on audio channels 3 and 4 depend on the settings of the AUDIO IN CH-3/CH-4 switches without being affected by the XLR connection automatic detection function.

Fitting the WRR-862 (Using a BP-GL65/GL95/L60S/M100 Battery Pack)

- 1 (1) Attach the WRR tuner fitting (not supplied, service part number: A-8278-057-A) to the back of the camcorder.
 - ① Use a Phillips type screwdriver to tighten the four screws placed in the tuner fitting. For three of these screws, insert the screwdriver through the corresponding hole and tighten the screw.
 - ② Loosen the adjustment screws.
 - ③ Adjust the tuner fitting position for a BP-GL65/GL95/L60S/M100 Battery Pack to be attached, and tighten the adjustment screws to fix its position.
 - ④ Attach the mount plate supplied with the WRR-862.
- (2) Attach the battery pack.

For details about attaching the BP-GL65/GL95/L60S/M100 Battery Pack, see 9-1-1 “Using a Battery Pack” on page 142.

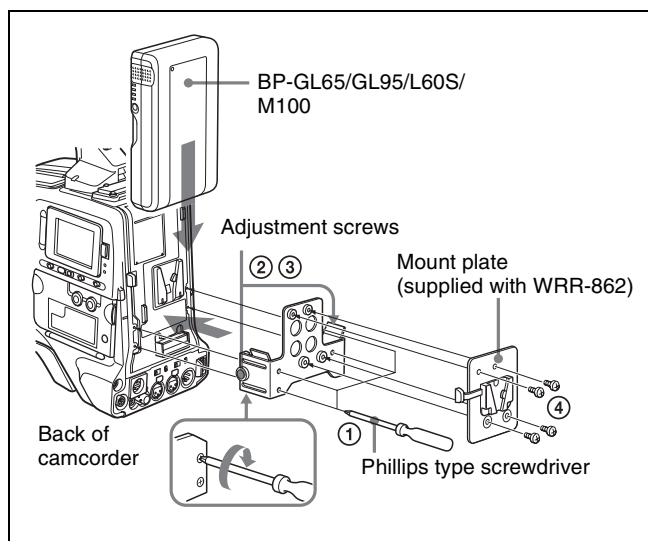

- 2 Mount the tuner on the WRR tuner fitting.

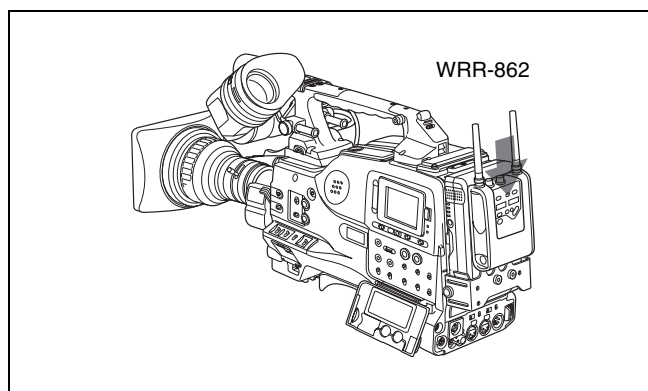

- 3 Connect the tuner power cord to the DC OUT connector of the camcorder, and the audio output cable to the AUDIO IN CH1 or CH2 connector.
- 4 Set the switches as follows.
 - Set the LINE / AES/EBU / MIC switch for the channel to which the audio out cable is attached to MIC.
 - When the XLR connection automatic detection function is off, set the AUDIO IN CH-1 or CH-2 switch for the channel to which the audio output cable is connected to REAR. If the XLR connection automatic detection function is on, the input signal for audio recording is selected automatically, and therefore this setting is not required.

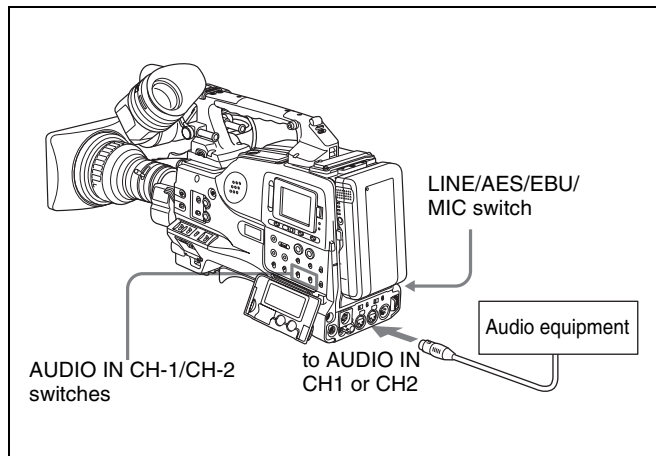
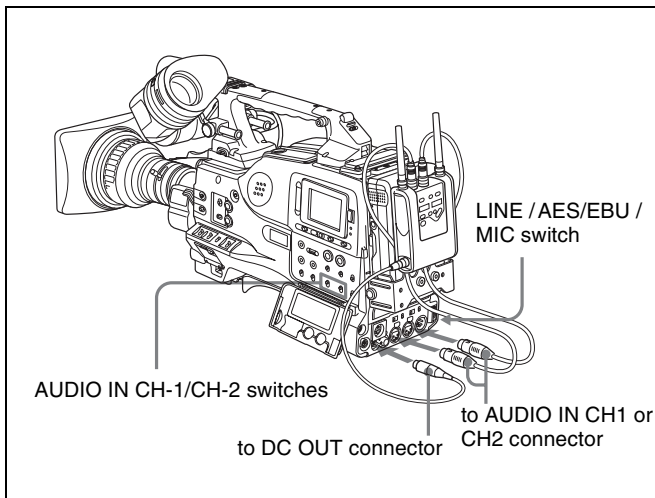

Line input connection

9-5-4 Connecting Line Input Audio Equipment

Connect the audio output connector of the audio equipment that supplies the line input signal to the AUDIO IN CH1 or CH2 connector.

Switch settings

Set the LINE / AES/EBU / MIC switch for the channel to which the audio signal source is connected to “LINE”.

Selecting the audio inputs to be recorded

- With the XLR connection automatic detection function being off (the factory default setting): A signal must be selected for audio recording by setting the AUDIO IN CH-1 or CH-2 switch to “REAR”, depending on which of the AUDIO IN CH1 and CH2 connectors is used for connecting the external audio equipment.
- With the XLR connection detection function being on: When a cable is connected to the AUDIO IN CH1 or CH2 connector, the input from that connector is automatically selected for audio recording, regardless of the setting of the AUDIO IN CH-1 or CH-2 switch.

The XLR connection automatic detection function can be switched on or off on the AUDIO-1 page of the MAINTENANCE menu, with the REAR XLR AUTO item.

9-6 Tripod Mounting

You can easily mount and dismount the camcorder on a tripod by using the VCT-14 tripod adaptor (not supplied).

- 1 Attach the tripod adaptor to the tripod.

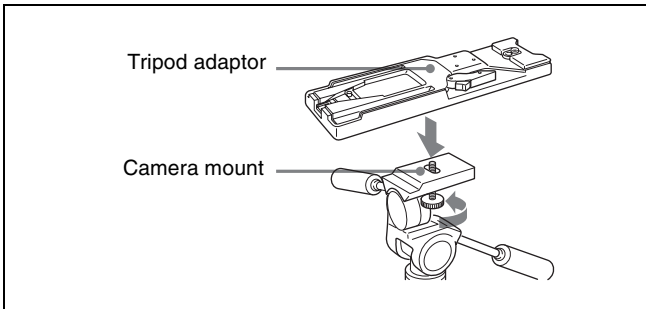

- 2 Mount the camcorder on the tripod adaptor.

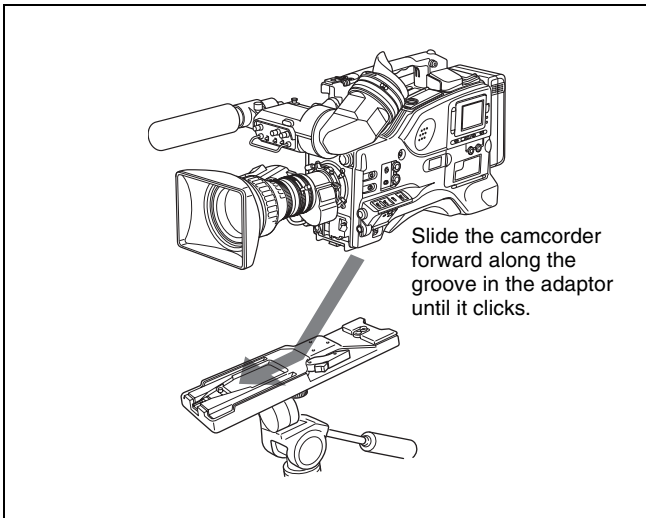

Removing the camcorder from the tripod adaptor

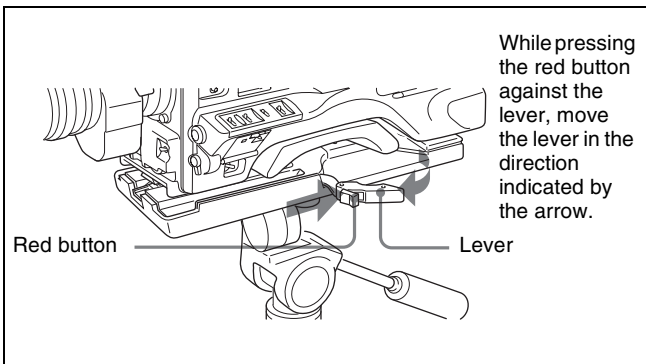

Removing the camcorder from the tripod adaptor

Note

The tripod adaptor pin may remain in the engaged position even after the camcorder is removed. If this happens, press the red button against the lever a second time and move the lever as shown below until the pin returns to the stowed position. If the pin remains in the engaged position, you will not be able to mount the camcorder on the tripod adaptor.

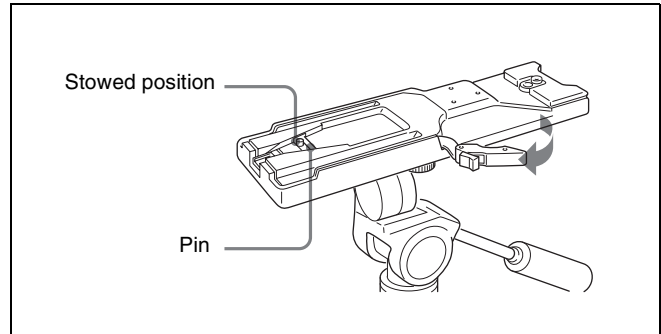

If the pin remains in the engaged position

9-7 Attaching the Shoulder Strap

Attach the supplied shoulder strap as shown below.

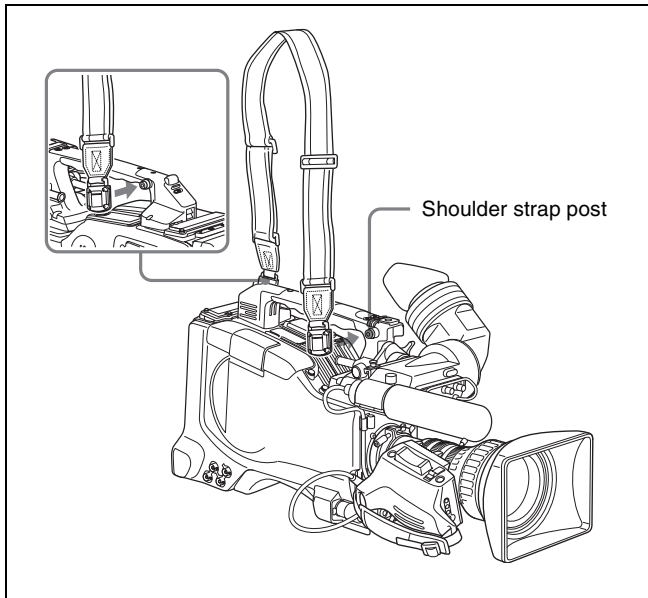

Attaching the shoulder strap

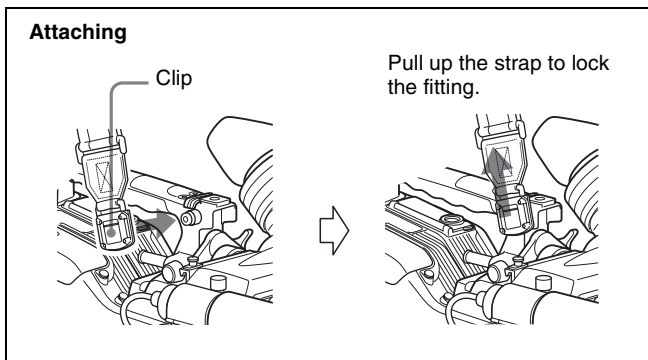

Attaching the shoulder strap

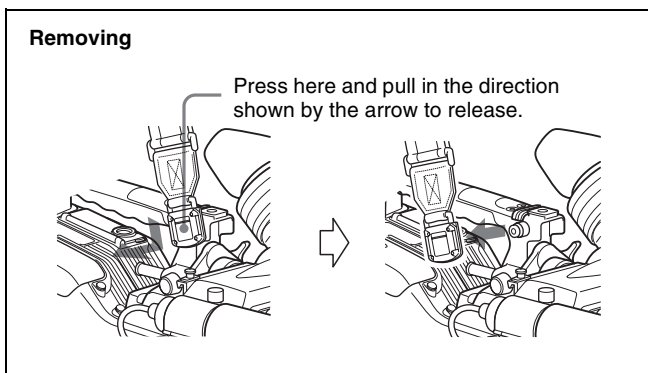

Removing the shoulder strap

9-8 Adjusting the Shoulder Pad Position

You can shift the shoulder pad from its center position (factory setting) backward by up to 10 mm (3/8 inch) or forward by up to 25 mm (1 inch). This adjustment helps you get the best balance for shooting with the camcorder on your shoulder.

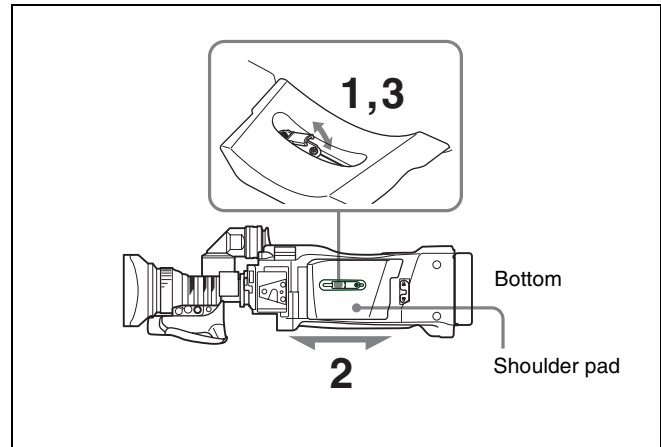

Adjusting the shoulder pad position

- 1** Raise the lever in the center of the shoulder pad to unlock the shoulder pad.
- 2** Slide the shoulder pad backward or forward until it is in the most convenient position.
- 3** Bring down the lever to lock the shoulder pad in the selected position.

9-9 Connecting the Remote Control Unit

Connecting the RM-B150/B750 Remote Control Unit enables remote control of the principal camera functions. Connecting the remote control unit to the REMOTE connector (8-pin) automatically puts the camcorder into remote control mode. If you disconnect the remote control unit, the remote control mode is cancelled.

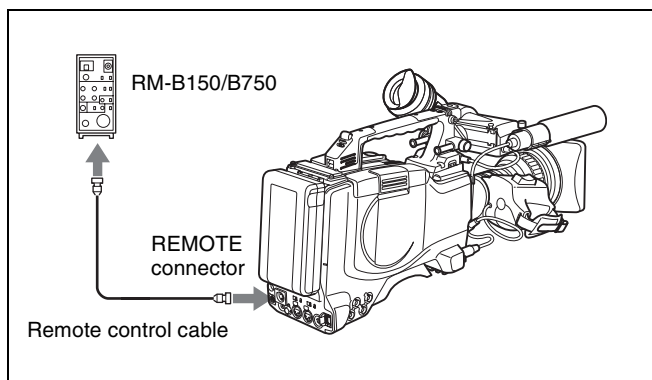

Camcorder switch functions when the remote control unit is connected

The following switches on the camcorder do not function.

- GAIN selector
- OUTPUT/DCC switch
- WHITE BAL switch
- AUTO W/B BAL switch
- SHUTTER selector
- TURBO GAIN button (ASSIGN 1 switch to which the TURBO GAIN function is assigned)
- REC START button (VTR button on the lens and the ASSIGN 1/3/4 or the TURBO GAIN switch to which the REC START/STOP function is assigned) (When the REC START/STOP item on the FUNCTION 3 page of the MAINTENANCE menu is set to RM.)

For details of the function of the REC START button, see the item “Function of the REC START button when the remote control unit is connected” on this page.

Paint adjustment when the remote control unit is connected

The settings of the paint adjustment that were in effect the last time the remote control unit was used are recalled.

Function of the REC START button when the remote control unit is connected

You can select the function of the REC START button on the camcorder when the remote control unit is connected, using the REC START/STOP item on the FUNCTION 3 page of the MAINTENANCE menu.

To disable the camcorder REC START button and the lens VTR button

On the FUNCTION 3 page of the MAINTENANCE menu, set REC START/STOP to “RM”.

If the same function as that of the REC START button is assigned to the ASSIGN 1/3/4 switch or the TURBO GAIN button, this setting also disables these controls.

To enable the camcorder REC START button and the lens VTR button

On the FUNCTION 3 page of the MAINTENANCE menu, set REC START/STOP to “CAM”.

If the same function as that of the REC START button is assigned to the ASSIGN 1/3/4 switch or the TURBO GAIN button, this setting also enables these controls.

To enable all of the camcorder REC START button, the lens VTR button, and the remote control unit VTR button

On the FUNCTION 3 page of the MAINTENANCE menu, set REC START/STOP to “PARA”.

If the same function as that of the REC START button is assigned to the ASSIGN 1/3/4 switch or the TURBO GAIN button, this setting also enables these controls.

When the monitor is connected to the MONITOR OUT connector of the remote control unit

The MONITOR connector (BNC type) of the RM-B150/B750 outputs the same signal as that from the TEST OUT connector on the camcorder.

Use the black cable supplied with the RM-B150/B750 to connect the monitor to the MONITOR connector on the RM-B150/B750.

When the remote control unit is disconnected from the camcorder

The camcorder settings return to the settings in effect before the remote control unit was connected.

By making a menu setting, the setting of the paint adjustment made with the remote control unit can be retained even after the remote control unit is removed from the camcorder.

For details, see “Structure of the paint adjustment data” on the next page.

Structure of the paint adjustment data

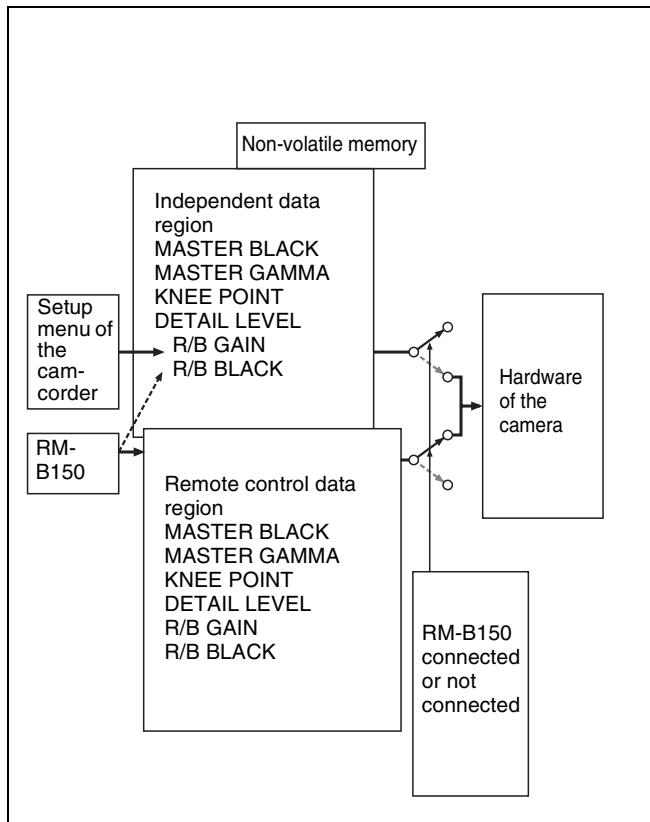

As the illustration above shows, the non-volatile memory of the camcorder consists of two regions: one is the independent data region that becomes effective when the remote control unit is not connected, and the other is the remote control data region that becomes effective when the remote control unit is connected. Paint adjustment data is automatically selected depending on whether or not the remote control unit is connected to the camcorder.

Thus, when the remote control unit is connected to the camcorder, the effective data region is switched to the remote control data region and the settings of the paint adjustment that were in effect the last time the remote control unit was used are recalled.

Settings of the absolute value control knobs ¹⁾ and absolute value switches ²⁾ are overwritten by those on the remote control unit after the remote control unit is connected.

1) Absolute value control knob

The data corresponding to the rotation degree (position) of the control knobs is output. The data corresponding to the rotation amount is called the relative value control knob.

2) Absolute value switch

Like the toggle switches or slide switches (except the momentary switches), the switches (or controls) whose positions must coincide with their functions are called absolute value switches.

When the remote control unit is removed from the camcorder, the independent data region becomes effective. Thus the camcorder will return to the settings that were in effect before the remote control unit was connected.

When RM COMMON MEMORY is set to ON on the FUNCTION 3 page of the MAINTENANCE menu, you

can use settings of the paint adjustment data stored in the independent data region even if you connect the remote control unit. In this case, the settings stored in the independent data region will be renewed when you change the settings on the remote control unit. Thus, the settings of the paint data made with the remote control unit can be retained even if the remote control unit is removed.

However, if the switch position on the remote control unit differs from the one on the camcorder, the switch position on the camcorder takes precedence over that on the remote control unit.

Also, it is possible to keep the settings that are in effect before you connect the remote control unit. In this case, you should set the control knob to the relative value mode on the remote control unit.

For details, refer to the operation manual supplied with the remote control unit.

10-1 Testing the Camcorder Before Shooting

Check the functions of the camcorder before setting out for a shooting session, preferably by operating the camcorder together with a color video monitor.

10-1-1 Preparations for Testing

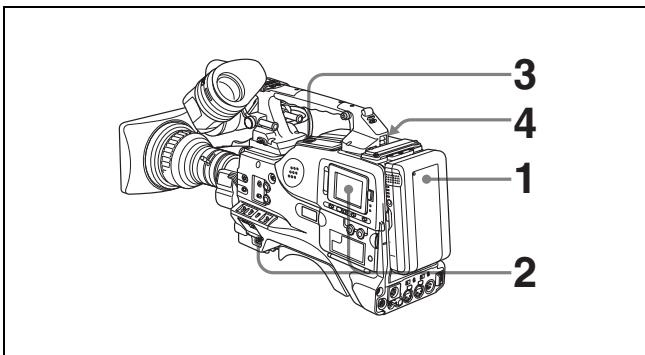

- 1** Attach a fully charged battery pack.
- 2** Set the POWER switch to ON and check that the HUMID indicator does not appear and that the BATT indicator shows at least five segments.
 - If the HUMID indicator appears, wait until it disappears.
 - If the BATT indicator does not show at least five segments, replace the battery pack with a fully charged one.
- 3** Check that there are no obstructions near the disc compartment, and then press the EJECT button to open the disc compartment lid.

- 4** After confirming that the disc is not write-protected, load the disc and close the disc compartment lid.

Condensation

If you move the camcorder from a very cold place to a warm place, or use it in a damp location, condensation may form on the optical pickup. Then, if the camcorder is operated in this state, recording and playback may not be performed properly.

Do the following to prevent this from happening.

- When you move or operate the camcorder in an environment where condensation may form, be sure to load a disc in advance and close the disc compartment lid.
- Whenever you turn on the power, check that the HUMID indicator does not appear on the color LCD. If it appears, wait until it disappears before loading a disc.

For details, see 3-1-4 “Loading and Unloading a Disc” on page 38 and 10-3 “Operation Warnings” on page 162.

10-1-2 Testing the Camera

Set the switches and selectors as follows.

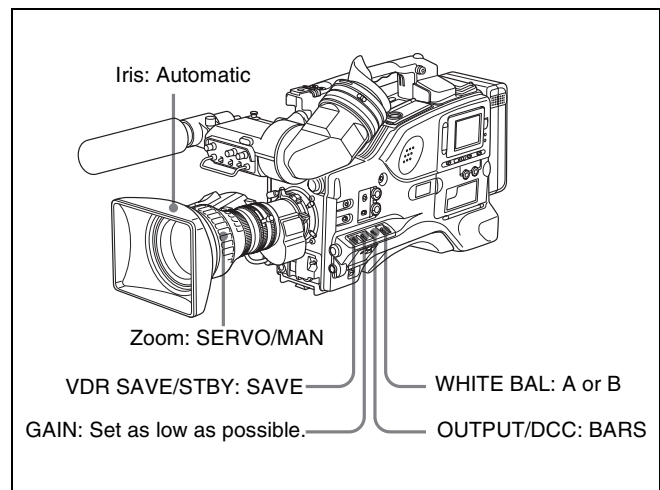

Testing the viewfinder

Proceed as follows.

- 1 Adjust the position of the viewfinder.
- 2 Check that the color bars are displayed on the viewfinder screen, and adjust the BRIGHT, CONTRAST, and PEAKING controls to give the best color bar display.
- 3 Check each of the following operations.
 - The menu is displayed on the viewfinder screen.
 - Turn the MENU knob and check that the menu page changes to the next page.
 - Press the MENU knob and check that settings of each item of the selected page are displayed.
 - Turn the MENU knob and check that the ➔ mark moves within the page.
 - Press the MENU knob and check that the ➔ mark placed before the item changes to a ● mark and the ● mark placed before the setting of the item changes to a ? mark.
 - Turn the MENU knob and check that the setting of the selected item changes.
- 4 Set the OUTPUT/DCC switch to CAM, and change the FILTER selector position in the sequence of 1, 2, 3 and 4.
Check that the FILTER indicator on the viewfinder screen displays the correct numbers.
- 5 Carry out of the following operations, and check that that the ! indicator lights if the corresponding item has been turned on on the '! LED page of the USER menu.
 - Set the gain to anything but 0 dB by using the GAIN selector and the GAIN SW page of the OPERATION menu.
 - Set the SHUTTER selector to ON.
 - Set the WHITE BAL switch to PRST.
 - Use the lens extender.
 - Set the FILTER selector to other than the position "1" (PDW-510/510P) or other than the position "1B" (PDW-530/530P).
 - Set the reference value of the auto iris to other than the standard value.
- 6 Move the SHUTTER selector from ON to SELECT repeatedly, and check that the shutter setting changes on the viewfinder screen.
- 7 Pointing the camera at a suitable subject, focus the camera and check the picture on the viewfinder screen.

- 8 Set both of the AUDIO IN switches to FRONT, and check that when sound is input to a microphone connected to the MIC IN connector on the front of the camcorder, the audio level indicators appear on the viewfinder screen.
- 9 Check that setting the ZEBRA switch to ON and OFF makes the zebra pattern appear and disappear on the viewfinder screen.

Note

The results of checking in steps 3 to 9 may not be as expected, depending on the settings relating to the viewfinder display function. In this case, set the desired items on the VF DISP 1 and VF DISP 2 pages of the USER menu.

For details, see 7-2-2 "Selecting the Display Items" on page 109.

Testing the iris and zoom functions

- 1 Set the zoom to automatic zoom mode and check that the power zoom operates correctly.
- 2 Set the zoom to manual zoom mode and check the zoom functions manually.
- 3 Set the iris switch on the lens to AUTO and point the camera at objects of different brightness. Check that the automatic iris adjustment operates correctly.
- 4 Set the iris switch on the lens to MANUAL and check that turning the iris ring manually adjusts the iris correctly.
- 5 Set the iris switch on the lens back to AUTO and check the following points when the GAIN selector is moved from L to M to H.
 - For objects of the same brightness, the iris is adjusted to correspond to the change in setting.
 - The gain indicator on the viewfinder screen changes to correspond to the change in setting.
- 6 If an extender mechanism is incorporated in your lens, put the extender lever of the lens into the 2x position and check the following points.
 - The indication "EX" appears at the top left on the viewfinder screen.
 - The auto iris functions correctly.

10-1-3 Testing the VDR

Perform tests (1) to (7) consecutively.

(1) Testing the recording and playback functions

- 1 Set the VDR SAVE/STBY switch to SAVE and check that the SAVE indicator in the viewfinder goes on.
- 2 Set the VDR SAVE/STBY switch to STBY and check that the SAVE indicator in the viewfinder goes off.
- 3 Set the switches located below the color LCD as follows.
LCD switch: L or H
DISP SEL switch: STATUS
DISPLAY switch: COUNTER
- 4 Set the PRESET/REGEN/CLOCK switch to PRESET, and set the F-RUN/SET/R-RUN to R-RUN.
- 5 Press the REC START button and check the following points.
 - The indication in the counter display is changing.
 - The REC indicator in the viewfinder is on.
 - The RF and SERVO indicators on the color LCD are off.
- 6 Press the REC START button again and check that recording stops and that the REC indicator in the viewfinder goes off.
- 7 Repeat the checks of steps 5 and 6, this time using the VTR button on the lens.

Press the RESET button and check that the indication in the counter display on each of the color and monochrome LCDs is "00:00:00:00".
- 8 Press the F REV button and check that fast reverse playback is performed. Next, press the PLAY button and check that normal playback is performed.
- 9 Press the STOP button and check that playback stops. Next, press the F FWD button and check that fast forward playback is performed.
- 10 Press the STOP button again, then press the PREV button. Check that the image of the beginning of the current or previous clip is displayed.
- 11 Press the NEXT button, and check that the image of the beginning of the next clip is displayed.

(2) Testing the automatic audio level adjusting functions

- 1 Set the AUDIO IN CH-1/CH-2 switches to FRONT.

- 2 Set the AUDIO SELECT CH-1/CH-2 switches to AUTO.
- 3 Set the AUDIO IN CH-3/CH-4 switches to F (front).
- 4 Aim the microphone connected to the MIC IN connector at a suitable sound source. Check that the level indications for channels 1 to 4 correspond to the sound level, respectively.

(3) Testing the manual audio level adjusting functions

- 1 Set the AUDIO IN CH-1/CH-2 switches to FRONT.
- 2 Turn the MIC LEVEL control. Check that the channel-1 and -2 audio level meters on the color and monochrome LCDs show more and more segments as you turn the control counterclockwise as seen from the front of the camcorder.

(4) Testing the earphone and speaker

- 1 Turn the MONITOR volume control and check that the speaker volume changes accordingly.
- 2 Connect an earphone to the front or rear EARPHONE jack. Check that the speaker sound is cut off and that you can hear the sound from the microphone in the earphone.
- 3 Turn the MONITOR volume control and check that the earphone volume changes accordingly.
- 4 Connect the earphone to the other EARPHONE jack. Check the earphone as in step 3.

(5) Testing external microphones

You can do this test by using both of the AUDIO IN CH1 and CH2 connectors simultaneously. Alternatively, you can do the test by using one of the connectors, and then execute the same procedure using the other connector. The following is the testing procedure when both connectors are used.

- 1 Connect external microphones to the AUDIO IN CH1/CH2 connectors.
- 2 Set the +48V/OFF switches as follows.
 - If the connected microphone is of the internal power supply type, set the switch to OFF.
 - If the connected microphone is of the external power supply type, set the switch to +48V.
- 3 Set the AUDIO IN CH-1/CH-2 switches to REAR.

- 4 Aim the microphones at a sound source.
- 5 Check that the audio level meters on the color and monochrome LCDs and the audio level indicators in the viewfinder reflect the changing sound level.

(6) Checking the XLR connection automatic detection function

Before starting to check, remove the front microphone connected to the MIC IN connector if it is connected.

- 1 Perform the operations of steps 1 and 2 explained in (5) “Testing external microphones”.
- 2 Set the AUDIO IN CH-1/CH-2 switches to FRONT.
- 3 Perform the operations of steps 4 and 5 explained in (5) “Testing external microphones”.

If the audio level meters on the color and monochrome LCDs and the audio level indicators in the viewfinder reflect the changing sound level, the function of the XLR connection automatic detection is working correctly.

If it does not reflect the changing sound level, the function of the XLR connection automatic detection function is off. Set REAR XLR AUTO to “ON” on the VDR MODE 1 page of the MAINTENANCE menu.

If it does not reflect even after making this setting, the XLR connection automatic detection function does not work correctly.

(7) Checking the user bit and time code functions

- 1 Set the user bits as required.

For the operation, see 5-6-3 “Setting the User Bits” on page 84.

- 2 Set the time code.

For the operation, see 5-6-1 “Setting the Time Code” on page 84.

- 3 Set the F-RUN/SET/R-RUN switch to R-RUN.
- 4 Press the REC START button, and check that recording starts and that the time code indication in the counter display changes.
- 5 Press the REC START button again, and check that recording stops and that the time code indication stops changing.

- 6 Set the F-RUN/SET/R-RUN switch to F-RUN, and check that the time code indication starts changing again and continues to change even when you restart recording and stop recording again.
- 7 Set the DISPLAY switch to U-BIT, and check that the user bit data that was set is displayed.

10-2 Maintenance

10-2-1 Cleaning the Viewfinder

Use a dust blower to clean the CRT screen and mirror inside the viewfinder barrel.

Clean the lens and protecting filter with a commercially available lens cleaner.

Caution

Never use organic solvents such as thinners.

Disassembling the eyepiece for cleaning

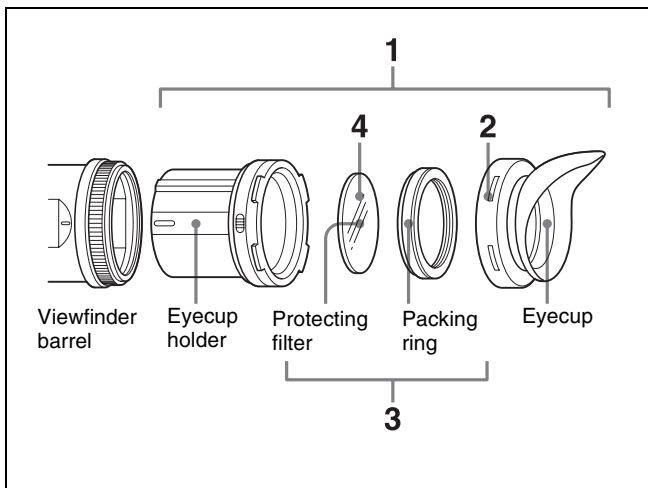

- 1 Detach the eyepiece from the viewfinder barrel.

For the detaching procedure, see 9-2-6 “Detaching the Eyepiece” on page 146.

- 2 Remove the eyecup from the eyecup holder.
- 3 Remove the protecting filter, together with the packing ring, from inside the eyecup holder.
- 4 Detach the protecting filter from the packing ring.

Fog-proof filter

Depending on the temperature and humidity, the protecting filter may mist because of vapor or your breath. To ensure that the viewfinder is always clear, replace the protecting filter with a fog-proof filter (Part No. 1-547-341-11, not supplied).

Fitting the fog-proof filter

Replace the protecting filter on the packing ring with the fog-proof filter.

Be sure to correctly assemble the fog-proof filter, the packing ring, and the eyecup so that the reassembled eyepiece is waterproof.

Note

When cleaning the fog-proof filter, wipe it very gently with a soft cloth to avoid damaging the anti-fogging coating.

10-3 Operation Warnings

When a problem occurs at power on or during operation, a warning is given by the relevant indicators on the color and monochrome LCDs, in the viewfinder and on the

camcorder body. The speaker and earphone also give audible warnings.

Operation warnings

Alarm Message	Indicators on color/ monochrome LCDs		Indicators in viewfinder/ on camcorder body			Warning sounds	Problem	VDR operation	Action to take
	Warning/ Battery status indication	Flashing/ continuous	:Continuous :4 flashes/s	WARNING	REC/tally				
E**_** 1)	–	–	2)	2)	–	: 4 beeps/s : 1 beep/s : Continuous beep	Recording error	Recording stops.	Turn off the power and consult your Sony representative.
MEM Full	–	–	2)	2)	–	2)	Shockproof memory overflow	Recording continuous but may be substandard.	Protect the unit from shocks and vibration.
ILL.REC!	–	–	2)	2)	–	2)	Input sync error	Recording continuous but may be substandard.	Turn off the power and contact your Sony service representative. (This indication may be given momentarily when a GENLOCK signal is connected or disconnected, but this does not indicate a problem.)
Disc Error!	–	–	2)	2)	–	2)	A disc defect was detected.	Recording continues, avoiding the defect, but may be substandard.	If defects are detected repeatedly, exchange the disc.
HUMID!	–	Continuous	2)	2)		2) 3)	Condensation on the optical pickup.	Recording/playback continues but stops when an error occurs on the drive.	Stop recording/playback, turn off the power, then turn it on again, and wait until the HUMID indicator disappears.
Before Full 8)	DISC	Flashing ⁴⁾	2)	2)		2)	Disc almost full.	Operation continues.	Be prepared to change the disc.
DISC FULL! 6)	DISC and E	Flashing ⁵⁾	6)	6)		6)	Disc full.	Recording stops.	Change the disc.
LOW BATT! 8)	BATT	Flashing ⁴⁾	7)	7)	7)	7)	Battery almost exhausted.	Operation continues. ⁵⁾	Change the battery.
BATT EMPTY!	BATT and E	Flashing ⁵⁾	7)	7)	7)	7)	Battery exhausted.	Operation stops.	Change the battery.
High TEMP!	–	–	7)	7)	–	7)	Internal temperature high.	Operation continues.	Power the unit off and move it to a cool place.

Alarm Message	Indicators on color/ monochrome LCDs		Indicators in viewfinder/ on camcorder body			Warning sounds	Problem	VDR operation	Action to take
	Warning/ Battery status indication	Flashing/ continuous	☀ :Continuous ☀☀ :4 flashes/s	WARNING	REC/tally				
ACC Sensor! Skew! Sensor	–	–	☀	☀	–	●●●●●●●● : 4 beeps/s ●●●●●●●● : 1 beep/s ●●●●●●●●●● : Continuou s beep	Internal drive sensor error	Operation continues.	Protect the unit from shock and vibrations, turn off the power, and contact a Sony service representative.

- 1) Asterisks (*) are replaced by digits in the display.
- 2) During recording
- 3) During playback, fast forward, fast reverse, or stop
- 4) 1 flash/second
- 5) 4 flashes/second

- 6) During recording pause
- 7) During recording or pause.
- 8) During recording, displayed in color LCD only (when the DISP SEL switch is set to STATUS).

Operation/error messages

An operation or error message is displayed in the operation/error message display area (*see page 107*) in the viewfinder.

Operation/error message	Meaning
AUTO INTERVAL **M**S	Indicates the camera is in the Auto Interval Rec mode. **M**S indicates the shooting interval.
MANU INTERVAL *FRAME	Indicates the camera is in the single shot mode of the Manual Interval Rec mode. *FRAME indicates the number of frames.
INTERVAL **S(M/H)*FRAME	Indicates the camera is in the consecutive mode of the Manual Interval Rec mode. **S(M/H) indicates the trigger interval and *FRAME indicates the number of frames.
LOW LIGHT	Appears, depending on the setting, to indicate the subject illumination is inadequate.
ON-BOARD BATTERY EMPTY	Appears when the backup battery for the internal clock has been used up. ¹⁾
HIGH TEMPERATURE	Indicates that temperatures have risen inside the unit. Avoid continued use in this state.

1) To replace the backup battery, contact your nearest Sony dealer.

A message for DVR operation is displayed in the setting change and adjustment progress message display area in the viewfinder (*see page 110*).

Message	Meaning and action to take
ILL. Disc!	The disc cannot be used by this unit. Insert another Professional Disc.
ILL. Index! No FS! Unknown FS!	Index file or file system error. Exchange or format the disc.

Message	Meaning and action to take
No Support!	A recorded clip cannot be handled by this unit. Exchange or format the disc.
FORMAT NG!	The disc cannot be used by this unit. Exchange the disc.
Disc Damage	The disc cannot be recorded. To record, exchange the disc.
Non AV Full MAX # Files	The disc is full. Exchange or format the disc.
DI read err Read err DRV ADJ err	The disc was not recognized. Try ejecting the disc and inserting it again. Or exchange the disc.
Run Salvage	Salvage processing needs to be done on the disc. To record on the disc, eject the disc, insert it again, and execute salvage processing.
Salvage NG	Salvage processing failed. For details, see 3-1-6 "Handling of Discs When Recording Does Not End Normally (Salvage Function)" (page 39).
REC INHI.!	The write-protect tab of the disc is in the recording disabled position, or salvage processing needs to be done on the loaded disc. Set the tab to the recording enabled position. Or eject the disc, insert it again, and perform salvage processing.
IMX** Clip ¹⁾ DVCAM Clip 4CH/24 Clip 8CH/16 Clip	The loaded disc has a different recording format. Exchange the disc, or change the recording format.
KEY INHI.!	²⁾ Disc operations are not possible when the DC IN connector is not connected and the CA-755 is being used.
ILL. PLAY	An A/V phase error occurred during playback. Stop the disc.
Lid Closed!	The lid of the disc compartment does not open. Check the lid.

Message	Meaning and action to take
Lid Open!	The lid of the disc compartment is not closed. Close it securely.
No Clip!	There are no clips recorded on the disc. Exchange for a recorded disc.
No Disc!	There is no disc loaded. Insert a disc and try the operation again.
STOP ONCE! REC mode!	The operation is not possible while the disc is being played or recorded. Stop the disc.
Disc Top! Disc End!	The operation is not possible because the disc is at the top or end.
Formatting!	The disc is being automatically formatted. Wait until the format ends.
Recording	The unit is writing to the file system. Wait until writing finishes.
No EM Space EM Full!	Essence marks cannot be inserted. For details, see 3-2-3 "Recording Essence Marks" (page 43).
SB CLP mode	Try the operation again after pressing the SUB CLIP button to turn off the sub clip indicator.
No SEL List	No clip list is selected. Create a new clip list, or load a clip list from the disc.
No List!	There is no clip list. Create a clip list.
No SUB Clip	There are no sub clips in the clip list. Register a sub clip, or load another clip list.
SUB Clip NG	The In and Out point positions are invalid. Set correct In and Out points.
MAX# SB CLP	The total number of sub clips is over the upper limit (300).
CL OVER DUR	The total duration of sub clips in the current clip list is over the upper limit (24 hours).
FAN Stopped! DR-FAN Stop	The main unit or drive fan has stopped. Avoid use under high temperatures, turn off the power, and contact a Sony service representative.

- 1) "*" indicates the bit rate (50/40/30).
2) REC INHI.! appears if you attempt to start recording.

Notes on CCD image sensors

Vertical smear

Smear tends to be produced when an extremely bright object is being shot; it is more likely to occur with a faster electronic shutter speed.

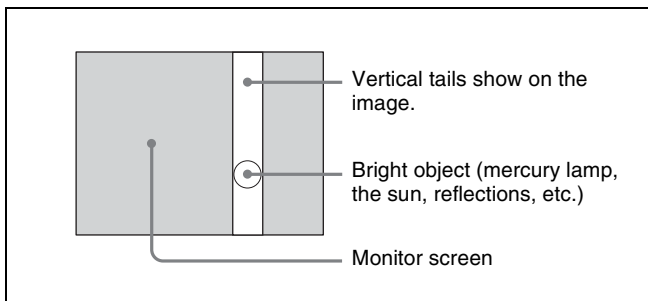

Vertical smear

Aliasing

When patterns of stripes or lines are shot, they may appear jagged.

Appendixes

Specifications

General

- Power voltage 12 V DC +5.0/-1.0 V
Power consumption
Approx. 32 W (with 12 V DC supply, when recording with the color LCD off)
Operating temperature
-5°C to +40°C (32°F to 104°F)
Operating humidity
10% to 90% (relative humidity)
Storage temperature
-20°C to +60°C (-4°F to +140°F)
Recording format
Video: MPEG IMX (50/40/30 Mbps), DVCAM (25 Mbps)
Proxy video: MPEG-4 ¹⁾
Audio:
MPEG IMX: 16 bits or 24 bits, 48 kHz, 4 channels
DVCAM: 16 bits/48 kHz
Proxy audio: A-law (8/4 channels, 8 bits, 8 kHz)

1) The MPEG-4 CODEC is a product of Ingenient Technologies, Inc.

- Continuous operating time
Approx. 120 min. (with BP-GL95)
Mass
Approx. 4.1 kg (9 lb) (main body only)
Approx. 5.7 kg (12 lb 9 oz) (with microphone, viewfinder, disc and BP-GL95 Battery Pack)

Dimensions in mm (inches)

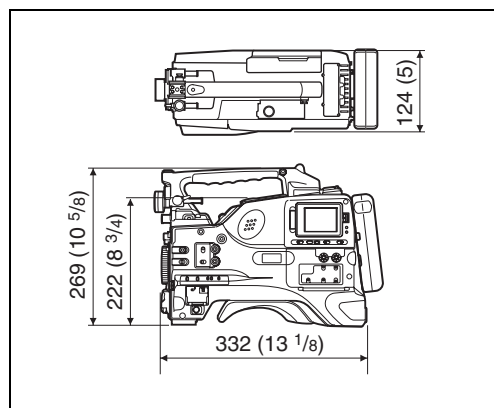

Supplied accessories

- Shoulder strap (1)
- Monaural microphone (super cardioid directional, external power supply type) (1)
- Operation manuals
 - English version (1)
 - Japanese version (1)
 - CD-ROM manual (1)
- PDZ-1 Proxy Browsing Software (1)

Video Camera Section

General

- Imager $\frac{2}{3}$ -inch type 16:9 widescreen Power HAD EX CCD
Total picture elements
1038 (H) × 1008 (V) for PDW-510/530
1038 (H) × 1188 (V) for PDW-510P/530P
Effective picture elements
980 (H) × 988 (V) for PDW-510/530
980 (H) × 1164 (V) for PDW-510P/530P
Imager Configuration
RGB 3 CCDs
Spectral system
F1.4 prism system (with quartz filter)

Built-in filters

PDW-510/510P

CC + ND filter

1: 3200K

2: 5600K + $\frac{1}{8}$ ND

3: 5600K

4: 5600K + $\frac{1}{64}$ ND

PDW-530/530P

CC filter

A: Cross filter

B: 3200K

C: 4300K

D: 6300K

ND filter

1: Clear

2: $\frac{1}{4}$ ND3: $\frac{1}{16}$ ND4: $\frac{1}{64}$ NDLens mount $\frac{2}{3}$ -inch 48 bayonet mount

Sensitivity

F11 standard (89.9% reflection chart, 2000 lx)

Minimum illumination

0.13 lx (at F1.4, +48 dB gain)

0.008 lx (F1.4, +48 dB, with 16-frame accumulation)

Video S/N ratio

65 dB (Y typical) (for PDW-510/530)

63 dB (Y typical) (for PDW-510P/530P)

Modulation (at screen center)

4:3 mode: 55%

16:9 mode: 70%

Registration

0.05% or less for entire screen area (excluding distortion due to lens)

Geometric distortion

None identified (excluding distortion due to lens)

Smear -140 dB (Y-typical)

LCD panel

6.3 cm (2.5 inches)

Pixel resolution: 211,200 pixels (960 wide \times 220 high)

Effective picture elements: more than 99.99%

Viewfinder

CRT 2-inch monochrome, quick start type

Horizontal resolution

4:3 mode: 600 TV lines (at screen center)

16:9 mode: 450 TV lines (at screen center)

Optical Disc Drive Section**General**

Usable disc PFD23 Professional Disc

Data transfer rate Max. 72Mbps (per optical head)

Recording/playback time

MPEG IMX 50Mbps: 45 minutes

40Mbps: 55 minutes

30Mbps: 68 minutes

DVCAM: 85 minutes

Digital video

Sampling frequency

Y: 13.5 MHz

R-Y/B-Y: 6.75 MHz

Quantization 10 bits/sample (8 bits/sample for compression processing)

Compression MPEG-2 4:2:2P@ML 50/40/30 Mbps or DVCAM

Audio (with standard playback machine)

Frequency response 20 Hz to 20 kHz -1.0 dB

Dynamic range 85 dB min.

Distortion (THD) 0.08% max.

Cross talk -70 dB max.

Wow and flutter Below measurable limit

Input/output connectors**Signal inputs**

AUDIO IN CH1/CH2

XLR type, 3-pin, female

-60 dBu/+4 dBu

(0 dBu = 0.775 Vrms.)

MIC IN

XLR type, 3-pin, female -60 dBu

GENLOCK IN

BNC type

1.0 Vp-p, 75 Ω , unbalanced

TC IN

BNC type

0.5 V to 18 Vp-p, 10 k Ω **Signal outputs**

TEST OUT BNC type

1.0 Vp-p, 75 Ω , unbalancedVIDEO OUT BNC type, 75 Ω , unbalanced

VBS OUT: 1.0 Vp-p

SDI OUT: 0.8 Vp-p (only when the CBK-SD01 is installed)

AUDIO OUT XLR type, 5-pin, male, 0 dBm

TC OUT BNC type, 1.0 Vp-p, 75 Ω

EARPHONE (minijack)

8 Ω , $-\infty$ to -18 dBs variable**Others**

DC IN XLR type, 4-pin, male, 11 to 17 V DC

DC OUT	4-pin, 11 to 17 V DC, maximum rated current 0.2 A
LENS	12-pin
REMOTE	8-pin
LIGHT	2-pin
i.LINK	6-pin

Recommended Additional Equipment

Power supply and related equipment

BP- GL65/GL95/L60S Battery Pack
 BP-M100 Battery Pack
 BC-M50/M150 Battery Charger
 AC-550/550CE AC Adaptor
 AC-DN10 AC Adaptor
 CA-701/702/702P Camera Adaptor

Viewfinder and related equipment

BKW-401 Viewfinder Rotation Bracket
 Fog-proof filter (Part No. 1-547-341-11)
 Lens assembly (farsighted) (Part No. A-8262-537-A)
 Lens assembly (low magnification) (Part No. A-8262-538-A)
 Lens assembly (standard magnification with special compensation for aberrations) (Part No. A-8267-737-A)

Optical attachments

ND filter ($\frac{1}{8}$ ND) (Part No. 3-174-685-01)
 ND filter ($\frac{1}{32}$ ND) (Part No. 3-174-683-01)

Consult your Sony representative for more information about these filters.

Equipment for remote control

RM-B150/B750 Remote Control Unit

“Memory Stick”

MSH-32 (32 MB)
 MSH-64 (64 MB)
 MSH-128 (128 MB)

Audio equipment

ECM-672 Microphone
 CAC-12 Microphone Holder
 CCXA-53 Audio Cable (for converting 5-pin connector to two 3-pin connectors)
 WRR-855A/855B UHF Synthesized Tuner Unit
 WRR-862 UHF Portable Tuner
 WRT-8T UHF Transmitter
 WRR Tuner Fitting (service part number: A-8278-057-A)
 STEREO MIC IN connector (MA-126A board) (service part number: A-1053-453-A)
 DMX-P01 Portable Digital Mixer

For Audio equipment described above, confirm whether the connector is male or female and the number of pins on the connector.

The audio input connectors of the camcorder are female and 3-pin and the audio output connectors are male and 5-pin. A converting adaptor may be required depending on the audio equipment to be connected to the camcorder.

Extension boards

CBK-SD01 SDI Output Board
 CBK-SC01 Composite Input Board
 CBK-FC01 Pull Down Board (for the PDW-510/530 only)
 CBK-NC01 Network Adaptor

Equipment for maintenance and easier handling

LC-777 Hard Carrying Case
 LC-DS300SFT Soft Carrying Case
 Tripod Adaptor VCT-14
 Maintenance Manual

Design and specifications are subject to change without notice.

Menu List

This section briefly explains menus that the camcorder provides for adjustments and settings using tables.

For the menu organization and the USER menu, see Chapter 6.

This manual also explains some adjustments and settings to be made using the OPERATION menu, PAINT menu, MAINTENANCE menu, FILE menu and DIAGNOSIS menu.

For details of these menus, refer to the Maintenance Manual.

OPERATION Menu List

The following table lists and describes the items in the OPERATION menu. Some pages of the OPERATION menu have been registered in the USER menu at the factory. These pages are indicated by a circle (○) in the USER menu column. The USER MENU CUSTOMIZE menu allows you to add and delete pages in the USER menu to suit your requirements.

When the setting range in the Settings column is surrounded by parentheses (), the setup value is a relative value. The setting range shown on the menu screen may differ from what is shown in the manual.

USER menu	No.	Page	Item	Settings	Default	Description
○	01	OUTPUT	LCD BRIGHT <L>	(-32 to +31)	0	See 7-3-2 "Selecting the Output Signals" on page 117.
			LCD BRIGHT <H>	(-32 to +31)	0	
			LCD COLOR	(-32 to +31)	0	
			i.LINK MODE	AV/C/FAM	AV/C	
			REAR BNC OUT SEL (when option board is connected)	VBS/SDI	VBS	

USER menu	No.	Page	Item	Settings	Default	Description
○	02	TEST OUT	TEST OUT MARKER	OFF/ON	OFF	Selects whether or not the marker signal is mixed to the output signal from the TEST OUT connector.
			TEST OUT VFDISP	OFF/ON	OFF	Selects whether or not the VF DISP display signal is mixed to the output signal from the TEST OUT connector.
			TEST OUT MENU	OFF/ON	OFF	Selects whether or not the MENU display signal is mixed to the output signal from the TEST OUT connector.
			TEST OUT DISP SEL	VF/LCD	VF	Selects VF (viewfinder) or LCD for the text information mixed to the output signal from the TEST OUT connector.
			TEST OUT ZEBRA	OFF/ON	OFF	Selects whether or not the ZEBRA display signal is mixed to the output signal from the TEST OUT connector.
			TEST OUT TC	OFF/ON	OFF	Selects whether or not a time code signal is mixed to the output signal from the TEST OUT connector.
			TEST OUT SELECT	ENC/R/G/B	ENC	Selects the output signal of TEST OUT.

USER menu	No.	Page	Item	Settings	Default	Description	
○	03	FUNCTION 1	ASSIGN SW <1>	OFF/CACHE/ CHARA/MARKR/ RTAKE/ATW/RET.V/ RET/REC/TURBO/ D5600/ZEBRA/ FREZE/M.FRZ etc.	ATW	<i>See 7-3-5 "Assigning Functions to ASSIGN 1/2/3/4 Switches" on page 120.</i>	
			ASSIGN SW <2>	OFF/CACHE/ CHARA/MARKR/ V.SRC/ZEBRA/ FREZE/5600 etc.	OFF		
			ASSIGN SW <3>	OFF/CACHE/ CHARA/MARKR/ RTAKE/ATW/RET.V/ RET/REC/TURBO/ ZEBRA/ZOOMW/ ZOOMT/FREZE/ M.FRZ etc.	OFF		
			ASSIGN SW <4>		OFF		
			TURBO SW	OFF/CACHE/ CHARA/MARKR/ RTAKE/ATW/RET.V/ RET/REC/TURBO/ D5600/ZEBRA/ FREZE/M.FRZ etc.	TURBO		
			DF/NDF (PDW-510/530 only)	DF/NDF	DF		Switches between drop frame (DF) mode and non-drop frame (NDF) mode.
			CACHE/INTVAL REC	OFF/CACHE/A.INT/ M.INT	OFF		<i>See 3-2-4 "Starting a Shoot with a Few Seconds of Pre-Stored Picture Data (Picture Cache Function)" on page 45</i>
			(CACHE) CACHE REC TIME	0-2/2-4/4-6/6-8/8-10/ 10-12s	0-2s		
			(A.INT) TAKE TOTAL TIME	5/10/15/20/30/40/50 MIN, 1/2/3/4/5/7/10/15/20/ 30/40/50/70/100 H	5MIN		<i>See 3-2-5 "Time-Lapse Video (Interval Rec Function)" on page 47.</i>
			(A.INT) REC TIME	5/10/15/20/30/40/50 SEC, 1 to 85 MIN	5SEC		
			(A.INT or M.INT except TRIGGER MODE:M) PRE-LIGHTING	OFF/2SEC/5SEC/ 10SEC	OFF		
			(M.INT) NUMBER OF FRAME	1/2/4/8	1		
			(M.INT) TRIGGER INTERVAL	M, 1 to 10/15/20/30/ 40/50 SEC, 1 to 10/15/20/30/40/ 50 MIN, 1/2/3/4/6/12/24H	1SEC		

USER menu	No.	Page	Item	Settings	Default	Description
	04	FUNCTION 2	D5600	OFF/ON	OFF	Turns on and off the function which electrically applies a 5600K color temperature filter.
			WIDE AWB	OFF/ON	ON	Turns on and off the function which widens the range adjustable by Auto White Balance.
			WHITE SWTCH 	MEM/ATW	MEM	Sets the function of the WHITE BAL B switch.
			SHOCKLESS WHITE	OFF/1/2/3	1	Changes the white gain smoothly when operating the WHITE BAL switch.
			ATW SPEED	1/2/3/4/5	4	Sets the convergence speed for Auto Tracing White balance.
			ZOOM SPEED	0 to 99	20	Sets the zoom speed when a serial lens is connected.
			LOW LIGHT	OFF/ON	OFF	Turns the warning display on or off when the video average level is less than the preset value.
			LOW LIGHT LEVEL	-99 to +99	16	Sets the level at which the LOW LIGHT function becomes effective.
			VF BATT WARNING	10/20%	10%	Sets the threshold value of remaining battery capacity to make the remaining capacity indication flash.
	05	POWER SAVE	i.LINK OUT	ENABL/DSABL	DSABL	See 7-3-2 "Selecting the Output Signals" on page 117.
			REC AUDIO OUT	EE/SAVE	EE	
			NETWORK/THUMB	STBY/SAVE	STBY	
○	06	VF DISP 1	VF DISP	OFF/ON	OFF	See 7-2-2 "Selecting the Display Items" on page 109.
			VF DISPLAY MODE	1/2/3	3	
			DISP EXTENDER	OFF/ON	ON	
			DISP FILTER	OFF/ON	ON	
			DISP WHITE	OFF/ON	ON	
			DISP GAIN	OFF/ON	ON	
			DISP SHUTTER	OFF/ON	ON	
			DISP AUDIO	OFF/ON	ON	
			DISP DISC	OFF/ON	ON	
			DISP IRIS	OFF/ON	ON	
○	07	VF DISP 2	DISP ZOOM	OFF/ON	ON	See 7-2-2 "Selecting the Display Items" on page 109.
			DISP COLOR TEMP	OFF/ON	OFF	
			DISP BATT REMAIN	INT/VOLT/AUTO	INT	
			DISP DC IN	OFF/ON	OFF	
			DISP 16:9/4:3 ID	OFF/ON	OFF	
			DISP WRR RF LVL	OFF/ON	OFF	
			DISP TIME CODE	OFF/ON	OFF	
			DISP REC FORMAT	OFF/ON	OFF	

USER menu	No.	Page	Item	Settings	Default	Description
○	08	"!LED	GAIN <!\>	OFF/ON	ON	See 2-10 "Indicators in the Viewfinder" on page 35.
			SHUTTER <!\>	OFF/ON	ON	
			WHT PRESET<!\>	OFF/ON	ON	
			ATW RUN <!\>	OFF/ON	ON	
			EXTENDER <!\>	OFF/ON	ON	
			FILTER <!\>	OFF/ON	OFF	
			OVERRIDE <!\>	OFF/ON	ON	
○	09	MARKER 1	MARKER	OFF/ON	OFF	See 7-2-4 "Setting the Marker Display" on page 111.
			CENTER	OFF/ON	OFF	
			SAFETY ZONE	OFF/ON	OFF	
			SAFETY AREA	80/90/92.5/95%	90%	
			ASPECT	OFF/ON	OFF	
			ASPECT SELECT	16:9/13:9/4:3	4:3	
			ASPECT MASK	OFF/ON	OFF	
			ASPECT MASK LVL	1/2, 1/4, 1/8	1/4	
			100% MARKER	OFF/ON	OFF	
	10	MARKER 2	USER BOX	OFF/ON	OFF	Turns the box cursor on or off.
			USER BOX WIDTH	1 to 465	245	Width (from the center to right or left side)
			USER BOX HEIGHT	1 to 120	72	Height (from the center to top or bottom)
			USER BOX H POS.	-461 to +461	0	H position of the center
			USER BOX V POS.	-118 to +118	0	V position of the center
			CENTER H POS.	-48 to +47	0	H position of the center marker
			CENTER V POS.	-15 to +14	0	V position of the center marker
○	11	GAIN SW	GAIN LOW	-3/0/3/6/9/12/18/24/ 30/36/42/48	0	See 7-3-1 "Setting Gain Values for the GAIN Selector Positions" on page 117.
			GAIN MID		9	
			GAIN HIGH		18	
			GAIN TURBO		42	
			TURBO SW IND.	OFF/ON	OFF	
○	12	VF SETTING	ZEBRA	OFF/ON	OFF	See 7-2-5 "Setting the Viewfinder" on page 111.
			ZEBRA SELECT	1/2/BOTH	1	
			ZEBRA1 DET.LEVEL	20 to 107	70	
			ZEBRA1 APT.LEVEL	1 to 20	10	
			ZEBRA2 DET.LEVEL	52 to 109	100	
			VF DETAIL LEVEL	-99 to +99	0	
			VF ASPECT	AUTO/16:9	AUTO	

USER menu	No.	Page	Item	Settings	Default	Description
○	13	AUTO IRIS	IRIS OVERRIDE	OFF/ON	OFF	See 5-4 “Changing the Reference Value for Automatic Iris Adjustment” on page 79.
			IRIS SPEED	(-99 to +99)	0	
			CLIP HIGH LIGHT	OFF/ON	OFF	
			IRIS WINDOW	1/2/3/4/5/6/VAR	1	
			IRIS WINDOW IND.	OFF/ON	OFF	
			IRIS VAR WIDTH	20 to 465	245	
			IRIS VAR HEIGHT	20 to 120	85/72	
			IRIS VAR H POS.	-447 to +446	0	
			IRIS VAR V POS.	-104 to +104	0	
○	14	SHOT ID	ID-1	12 characters	—	See 7-2-7 “Setting the Shot ID” on page 113.
			ID-2			
			ID-3			
			ID-4			
○	15	SHOT DISP	SHOT DATE	OFF/ON	OFF	See 7-2-6 “Recording Shot Data Superimposed on the Color Bars” on page 112.
			SHOT TIME	OFF/ON	OFF	
			SHOT MODEL NAME	OFF/ON	OFF	
			SHOT SERIAL NO	OFF/ON	OFF	
			SHOT ID SEL	OFF/ID-1/ID-2/ID-3/ID-4	OFF	
			SHOT 16:9 ID	OFF/ON	OFF	
SHOT BLINK CHARA	OFF/ON	OFF				
○	16	SET STATUS	STATUS ABNORMAL	OFF/ON	ON	See 7-2-8 “Displaying the Status Confirmation Windows” on page 114.
			STATUS FUNTION	OFF/ON	ON	
			STATUS AUDIO	OFF/ON	ON	
	17	OFFSET WHT	OFFSET WHITE <A>	OFF/ON	OFF	See 7-3-4 “Specifying an Offset for the Auto White Balance Setting” on page 119.
			WARM COOL <A>	Display color temperature	3200	
			COLOR FINE <A>	(-99 to +99)	0	
			OFFSET WHITE 	OFF/ON	OFF	
			WARM COOL 	Display color temperature	3200	
	18	SHT ENABLE	SHUTTER SLS	OFF/ON	ON	See 5-3 “Setting the Electronic Shutter” on page 76. The items which can be set differ depending on the CCD scan mode setting (see page 125).
			SHUTTER ECS	OFF/ON	ON	
			SHUTTER 1/60	OFF/ON	ON	
			SHUTTER 1/100	OFF/ON	ON	
			SHUTTER 1/125	OFF/ON	ON	
			SHUTTER 1/250	OFF/ON	ON	
			SHUTTER 1/500	OFF/ON	ON	
			SHUTTER 1/1000	OFF/ON	ON	
SHUTTER 1/2000	OFF/ON	ON				
○	19	LENS FILE	LENS FILE SELECT	1 to 32	1	See 7-3-7 “Selecting the Lens File” on page 122.
			F.ID	(Display only)	—	
			L.ID	(Display only)	—	
			L.MF	(Display only)	—	

USER menu	No.	Page	Item	Settings	Default	Description
	20	FORMAT	16:9/4:3 SELECT	16:9/4:3	16:9	See 7-3-8 "Selecting the Aspect Ratio" on page 123.
			SCAN MODE	I/PsF/24P (24P only when option board installed)	I	See 7-3-9 "Setting the CCD Scan Mode" on page 124.
			UC/J SELECT (PDW-510/530 only)	UC/J	UC	Selects the signal format.
	21	SOURCE SEL	REC VIDEO SOURCE	CAM/EXT	CAM	See 3-4 "Recording Video Signals from External Equipment" on page 58.
			EXT REC CONTROL	OFF/ON	OFF	
			PC REMOTE	ENABL/DSABL	DSABL	
			FRONT MIC SELECT (when stereo microphone is connected)	MONO/STREO	STREO	
			EXT VIDEO SOURCE (when option board is connected)	i.LINK/CMPST	i.LINK	
			EXT OUTPUT DELAY (when option board is connected)	SYNC/VIDEO	SYNC	
			SETUP REMOVE (PDW-510/530 only)	0.0/7.5	7.5	
	22	UMID SET	COUNTRY CODE	4-byte alphanumeric strings	—	See 7-3-10 "Using UMID Data" on page 126
			ORGANIZATION	4-byte alphanumeric strings	—	
			USER CODE	4-byte alphanumeric strings	—	
			TIME ZONE : 00	00 to xx	00	

PAINT Menu List

The following table lists and describes the items in the PAINT menu.

When the setting range in the Settings column is surrounded by parentheses (), the setup value is a relative

value. The setting range shown on the menu screen may differ from what is shown in the manual.

No.	Page	Item	Settings	Default	Description
01	SW STATUS	GAMMA	OFF/ON	ON	Turns the gamma correction on or off.
		CHROMA	OFF/ON	ON	Turns the chroma of the composite signal on or off.
		MATRIX	OFF/ON	OFF	Turns the linear matrix correction on or off.
		KNEE	OFF/ON	ON	Turns the knee correction on or off.
		WHITE CLIP	OFF/ON	ON	Turns the white clipping correction on or off.
		DETAIL	OFF/ON	ON	Turns the detail signal on or off.
		APERTURE	OFF/ON	ON	Turns the aperture function on or off.
		FLARE	ON/OFF	ON	Turns the flare function on or off.
		EVS	OFF/ON	OFF	Turns the EVS shutter on or off.
		TEST SAW	OFF/REC/SAW	OFF	Selects the test signal.
02	WHITE	COLOR TEMP <A>	Display color temperature	3200	Sets the color temperature of WHITE A.
		COLOR FINE <A>	(-99 to +99)	0	Adjusts the value more precisely when the color temperature adjustment through COLOR TEMP is not satisfactory.
		R GAIN <A>	(-99 to +99)	0	Only the value of R GAIN is changed.
		B GAIN <A>	(-99 to +99)	0	Only the value of B GAIN is changed.
		D5600 <A>	OFF/ON	OFF	Turns the WHITE A electronic 5600K filter on or off.
		COLOR TEMP 	Display color temperature	3200	Sets the color temperature of WHITE B.
		COLOR FINE 	(-99 to +99)	0	Adjusts the value more precisely when the color temperature adjustment through COLOR TEMP is not satisfactory.
		R GAIN 	(-99 to +99)	0	Only the value of R GAIN is changed.
		B GAIN 	(-99 to +99)	0	Only the value of B GAIN is changed.
		D5600 	OFF/ON	OFF	Turns the WHITE B electronic 5600K filter on or off.
03	BLACK/FLARE	MASTER BLACK	(-99 to +99)	0	Adjusts the master black level.
		R BLACK	(-99 to +99)	0	Adjusts the R black level.
		B BLACK	(-99 to +99)	0	Adjusts the B black level.
		MASTER FLARE	(-99 to +99)	0	Adjusts the flare level of the master.
		R FLARE	(-99 to +99)	0	Adjusts the R flare level.
		G FLARE	(-99 to +99)	0	Adjusts the G flare level.
		B FLARE	(-99 to +99)	0	Adjusts the B flare level.
		FLARE	OFF/ON	ON	Turns the flare correction circuit on or off.
		TEST OUT SELECT	ENC/R/G/B	ENC	Selects the output signal of TEST OUT connector.

No.	Page	Item	Settings	Default	Description
04	GAMMA	GAMMA	OFF/ON	ON	Turns the gamma correction function on or off.
		STEP GAMMA	0.35 to 0.90	0.45	Sets the master gamma correction curve in steps.
		MASTER GAMMA	(-99 to +99)	0	Sets the master gamma correction curve.
		R GAMMA	(-99 to +99)	0	Sets the R gamma correction curve.
		G GAMMA	(-99 to +99)	0	Sets the G gamma correction curve.
		B GAMMA	(-99 to +99)	0	Sets the B gamma correction curve.
		TEST OUT SELECT	ENC/R/G/B	ENC	Selects the output signal of TEST OUT connector.
		GAMMA SELECT	STD/FILM	STD	Selects the gamma table.
		GAMMA SEL (STD)	1 to 6	3	Selects the gamma table of STD.
		GAMMA SEL (FILM)	1 to 5	1	Selects the gamma table of FILM.
05	BLK GAMMA	BLACK GAMMA	OFF/ON	OFF	Turns the black gamma correction on or off.
		BLK GAMMA RANGE	LOW/L.MID/ H.MID/HIGH	HIGH	Sets the range affected by black gamma.
		MASTER BLK GAMMA	(-99 to +99)	0	Adjusts the master black gamma.
		R BLACK GAMMA	(-99 to +99)	0	Sets the correction curve of the R black gamma.
		G BLACK GAMMA	(-99 to +99)	0	Sets the correction curve of the G black gamma.
		B BLACK GAMMA	(-99 to +99)	0	Sets the correction curve of the B black gamma.
		TEST OUT SELECT	ENC/R/G/B	ENC	Selects the output signal of TEST OUT connector.
06	KNEE	KNEE	OFF/ON	ON	Turns the knee correction circuit on or off.
		KNEE POINT	50 to 109%	85.0	Sets the knee point level.
		KNEE SLOPE	(-99 to +99)	0	Set the knee slope level.
		KNEE SATURATION	OFF/ON	ON	Turns the knee saturation function on or off.
		KNEE SAT LEVEL	(-99 to +99)	0	Sets the knee saturation level.
		WHITE CLIP	OFF/ON	ON	Turns the white clipping function on or off.
		WHITE CLIP LEVEL	100.0 to 109.5%	109.0	Adjusts the white clipping level.
07	DETAIL 1	DETAIL	OFF/ON	ON	Sets the detail correction function on or off.
		APERTURE	OFF/ON	ON	Turns the aperture correction function on or off.
		DETAIL LEVEL	(-99 to +99)	0	Sets the general level of the detail signal.
		APERTURE LVL	(-99 to +99)	0	Sets the aperture level.
		DTL H/V RATIO	(-99 to +99)	0	Sets the level of the V detail signal.
		CRISPENING	(-99 to +99)	0	Sets the crispening level.
		LEVEL DEPEND	OFF/ON	ON	Turns the level depend function on or off.
		LV. DEPEND LVL	(-99 to +99)	0	Sets the level of the level depend.
DETAIL FREQ.	(-99 to +99)	0	Sets the frequency of the H detail signal.		

No.	Page	Item	Settings	Default	Description
08	DETAIL 2	KNEE APERTURE	OFF/ON	OFF	Turns the knee aperture function on or off.
		KNEE APT LVL	(-99 to +99)	0	Sets the knee aperture level.
		DETAIL COMB	(-99 to 0)	0	Sets the level at which the comb filter becomes effective.
		CROSS COLOR	ON/OFF	OFF	Turns the cross color component on or off.
		CROSS COLOR LVL	(0 to +99)	43	Sets the suppression level of the cross color.
		DETAIL LIMIT	(-99 to +99)		Sets the both detail black and white limiters.
		DTL WHT LIMIT	(-99 to +99)	0	Sets the detail white limiter.
		DTL BLK LIMIT	(-99 to +99)	0	Sets the detail black limiter.
		DTL V-BLK LMT	(-99 to +99)	0	Sets the V detail black limiter.
09	DETAIL 3	FINE DTL	OFF/ON	OFF	Turns the fine detail function on or off.
		FINE DTL LVL	(-99 to +99)	0	Sets the level at which the fine detail function becomes effective.
		V DTL CREATION	NAM/G/R+G/Y	R+G	Selects the source signal of the V DTL signal.
		H/V CONTROL MODE	H/V / V	V	Select the operation mode of DETAIL H/V RATIO on the DETAIL 1 page. (H/V: H and V both enabled, V: V DTL only enabled)
10	SKIN DETAIL	SKIN DETAIL	OFF/ON	OFF	Turns on all of 1, 2 and 3 of the color detail function.
		SKIN DETECT	Moves to color detection page.	EXEC	Executes the color detail function.
		SKIN AREA IND.	OFF/ON	OFF	Turns the zebra indication on or off in the area of the currently selected type of the color detail function.
		SKIN DTL SELECT	1/2/3	1	Selects the type of the color detail function. The following items depend on the selected type of the color detail function.
		SKIN DETAIL	OFF/ON	ON	Turns the color detail function on or off for the type selected in the above item.
		SKIN DETAIL LVL	(-99 to +99)	0	Sets the level of the color detail signal.
		SKIN DTL SAT.	(-99 to +99)	0	Adjusts the saturation level of the hue possessed by the color detail function.
		SKIN DTL HUE	(0 to 359)	0	Adjusts the center phase of the hue possessed by the color detail function.
		SKIN DTL WIDTH	(0 to 359)	40	Adjusts the width of the hue possessed by the color detail function.

No.	Page	Item	Settings	Default	Description
11	MTX LINEAR	MATRIX	OFF/ON	OFF	Turns the linear matrix correction and user-set matrix correction functions on or off.
		MATRIX (USER)	OFF/ON	OFF	Turns the user-set matrix correction function on or off.
		MATRIX (PRESET)	OFF/ON	ON	Turns the preset matrix correction function on or off.
		MATRIX (USER) R-G	(-99 to +99)	0	Sets the arbitrary G-R user-set matrix coefficients.
		MATRIX (USER) R-B	(-99 to +99)	0	Sets the arbitrary B-R user-set matrix coefficients.
		MATRIX (USER) G-R	(-99 to +99)	0	Sets the arbitrary R-G user-set matrix coefficients.
		MATRIX (USER) G-B	(-99 to +99)	0	Sets the arbitrary B-G user-set matrix coefficients.
		MATRIX (USER) B-R	(-99 to +99)	0	Sets the arbitrary R-B user-set matrix coefficients.
		MATRIX (USER) B-G	(-99 to +99)	0	Sets the arbitrary G-B user-set matrix coefficients.
12	MTX MULTI	MATRIX	OFF/ON	ON	Turns the linear matrix correction and multi matrix correction functions on or off.
		MATRIX (MULTI)	OFF/ON	OFF	Turns the multi matrix correction function on or off.
		MATRIX AREA IND.	OFF/ON	OFF	Turns the zebra indication on or off in the area corresponding to the currently selected setting.
		MATRIX COLOR DET	Moves to color detection page.	EXEC	Detects color.
		MTX (MULTI) AXIS	B/B+/MG-/MG/ MG+/R/R+/YL-/ YL/YL+/G-/G/ G+/CY/CY+/B-	B	Sets the region in which the multi matrix correction function can be changed. (sixteen-axis mode)
		MTX (MULTI) HUE	(-99 to +99)	0	Adjusts the color phase affected by the multi matrix correction function in every sixteen-axis mode.
		MTX (MULTI) SAT	(-99 to +99)	0	Adjusts the saturation level affected by the multi matrix correction function in every sixteen-axis mode.
13	V MODULATION	V MOD	OFF/ON	ON	Turns the V modulation function on or off.
		MASTER VMOD EX	(-99 to +99)	0	Turns the master V modulation function on or off.
		R VMOD	(-99 to +99)	0	Turns the R V modulation function on or off.
		G VMOD	(-99 to +99)	0	Turns the G V modulation function on or off.
		B VMOD	(-99 to +99)	0	Turns the B V modulation function on or off.
		TEST OUT SELECT	ENC/R/G/B	ENC	Selects the output signal of TEST OUT.

No.	Page	Item	Settings	Default	Description
14	LOW KEY SAT.	LOW KEY SAT.	OFF/ON	OFF	Turns the low key saturation function on or off.
		L.KEY SAT. LEVEL	(-99 to +99)	0	Sets the saturation level of the low luminance part.
		L.KEY SAT. RANGE	LOW/L.MID/ H.MID/HIGH	HIGH	Sets the luminance level at which the low key saturation function becomes effective.
		Y BLACK GAMMA	OFF/ON	OFF	Turns the Y black gamma function on or off.
		Y BLK GAM LEVEL	(-99 to +99)	0	Sets the gamma curve in the low luminance part.
		Y BLK GAM RANGE	LOW/L.MID/ H.MID/HIGH	HIGH	Sets the luminance level at which the Y black gamma becomes effective.
15	SCENE FILE	1	—	—	Recalls the scene file saved in the memory of the camcorder.
		2	—	—	
		3	—	—	
		4	—	—	
		5	—	—	
		STANDARD	—	—	Clears all current detail-adjusted settings and switch settings and returns the settings to the standard settings saved in the reference file.
		SCENE RECALL	—	—	Recalls the scene file from the memory of the camcorder or the "Memory Stick".
		SCENE STORE	—	—	Stores the scene file in the memory of the camcorder or the "Memory Stick".
		F.ID	16 characters	—	Sets the File ID.

MAINTENANCE Menu List

The following table lists and describes the items in the MAINTENANCE menu.

When the setting range in the Settings column is surrounded by parentheses (), the setup value is a relative value. The setting range shown on the menu screen may differ from what is shown in the manual.

No.	Page	Item	Settings	Default	Description
01	WHT SHADING	SHADING CH SEL	R/G/B/TEST	R	Selects the channel adjusted by this menu. If TEST is selected, the setting is the same as the setting of TEST OUT SELECT.
		TEST OUT SELECT	ENC/R/G/B	ENC	Selects the signal output to the TEST OUT connector.
		R/G/B WHT H SAW	(-99 to +99)	0	H Saw white shading compensation
		R/G/B WHT H PARA	(-99 to +99)	0	H Parabola white shading compensation
		R/G/B WHT V SAW	(-99 to +99)	0	V Saw white shading compensation
		R/G/B WHT V PARA	(-99 to +99)	0	V Parabola white shading compensation
		WHITE SAW/PARA	OFF/ON	0	Turns white shading Saw and Parabola compensation on and off.
02	BLK SHADING	SHADING CH SEL	R/G/B/TEST	R	Selects the channel adjusted by this menu. If TEST is selected, the setting is the same as the setting of TEST OUT SELECT.
		TEST OUT SELECT	ENC/R/G/B	ENC	Selects the signal output to the TEST OUT connector.
		R/G/B BLK H SAW	(-99 to +99)	0	H Saw black shading compensation
		R/G/B BLK H PARA	(-99 to +99)	0	H Parabola black shading compensation
		R/G/B BLK V SAW	(-99 to +99)	0	V Saw black shading compensation
		R/G/B BLK V PARA	(-99 to +99)	0	V Parabola black shading compensation
		BLACK SAW/PARA	OFF/ON	ON	Turns black shading Saw and Parabola compensation on and off.
		MASTER BLACK	(-99 to +99)	0	Master black level adjustment
		MASTER GAIN(TMP)	-3/0/3/6/9/12/18/24/30/36/42/48 dB	0 db	Temporarily adjusts the master gain value.
03	LEVEL ADJ	ENC VIDEO LEVEL	(-99 to +99)	0	Encoder video level adjustment
		RGB LEVEL	(-99 to +99)	0	R/G/B video level adjustment
		TEST OUT SELECT	ENC/R/G/B	ENC	Selects the signal output to the TEST OUT connector.
		H BLANKING WIDTH	(-99 to +99)	0	H blanking width adjustment

No.	Page	Item	Settings	Default	Description
04	BATTERY 1	BEFORE END 1	5/10 to 95/100%	5%	Used when a BP-GL65/GL95/M100 Battery Pack is used. Sets the voltage warning level just before the battery ends. ¹⁾
		END 1	0/1/2/3/4/5%	0%	Used when a BP-GL65/GL95/M100 Battery Pack is used. Sets the voltage level at which the battery ends and the camcorder stops operation, just before the battery ends. ²⁾
		BEFORE END 2	11.5 to 17.0 V (in 0.1 V steps)	11.5	Used when a BP-L60S Battery Pack is used. Sets the voltage warning level just before the battery ends. ¹⁾
		END 2	11.0 to 11.5 V (in 0.1 V steps)	11.0	Used when a BP-L60S Battery Pack is used. Sets the voltage level at which the battery ends and the camcorder stops operation, just before the battery ends. ²⁾
		BEFORE END 3	11.5 to 17.0 V (in 0.1 V steps)	11.8	Used when a battery pack other than a BP-GL65/GL95/L60S/M100 or an external power connected to the DC IN connector is used. Sets the voltage warning level just before the battery ends.
		END3	11.0 to 14.0 V (in 0.1 V steps)	11.0	Used when a battery pack other than a BP-GL65/GL95/L60S/M100 or an external power connected to the DC IN connector is used. Sets the voltage level at which the battery ends and the camcorder stops operation, just before the battery ends.

No.	Page	Item	Settings	Default	Description	
05	BATTERY 2	TYPE DETECTION	AUTO/OTHER	AUTO	AUTO: Automatically detects the type of the battery. OTHER: Always judges the battery to be of the "Others" ³⁾ type regardless of the actual battery type.	
		SEGMENT NO.7	11.0 to 17.0 V (in 0.1 V steps)	17.0	When the battery type judgment is "Others", sets the voltage level below which the battery status indicator segment No.7 should turn off.	Battery status indicator segments E ■■■■■■ F 1 2 3 4 5 6 7 (“E” ⁴⁾ and “F” are always on.)
		SEGMENT NO.6	11.0 to 17.0 V (in 0.1 V steps)	16.0	When the battery type judgment is "Others", sets the voltage level below which the battery status indicator segment No. 6 should turn off.	
		SEGMENT NO.5	11.0 to 17.0 V (in 0.1 V steps)	15.0	When the battery type judgment is "Others", sets the voltage level below which the battery status indicator segment No. 5 should turn off.	
		SEGMENT NO.4	11.0 to 17.0 V (in 0.1 V steps)	14.0	When the battery type judgment is "Others", sets the voltage level below which the battery status indicator segment No. 4 should turn off.	
		SEGMENT NO.3	11.0 to 17.0 V (in 0.1 V steps)	13.0	When the battery type judgment is "Others", sets the voltage level below which the battery status indicator segment No. 3 should turn off.	
		SEGMENT NO.2	11.0 to 17.0 V (in 0.1 V steps)	12.0	When the battery type judgment is "Others", sets the voltage level below which the battery status indicator segment No. 2 should turn off.	
		SEGMENT NO.1	11.0 to 17.0 V (in 0.1 V steps)	11.0	When the battery type judgment is "Others", sets the voltage level below which the battery status indicator segment No. 1 should turn off.	

No.	Page	Item	Settings	Default	Description
06	AUDIO-1	CA-701 AUDIO IN	ENABL/DSABL	ENABL	When a CA-701 camera adaptor is connected, selects whether or not to enable input of audio channels 3 and 4 from the camera adaptor. ENABL: Camera adaptor can be used. DSABL: Camera adaptor cannot be used.
		AUDIO CH3/4 MODE	CH1/2/SW	SW	Selects the sources to be recorded to channels CH-3/4. CH1/2: Same sources as CH-1/2. SW: Signals selected by the AUDIO IN CH-3/CH-4 switches.
		REAR XLR AUTO	OFF/ON	OFF	Turns the XLR connection automatic detection on or off .
		FRONT MIC REF	-60 dB/-50 dB/ -40 dB	-60 dB	Sets the reference level of the front microphone.
		REAR MIC REF	-60 dB/-50 dB/ -40 dB	-60 dB	Sets the reference level when the AUDIO IN CH1 connector is set to MIC.
		MIN ALARM VOL	OFF/SET	OFF	Volume of the monitor speaker alarm tone when it is turned all the way down. OFF: Almost inaudible. SET: Faintly audible.
		SP ATT LEVEL	OFF/3/6/9 dB	OFF	Lowers the volume of the monitor speaker. Has no effect on earphone volume.
		HEADPHONE OUT	STREO/MONO	MONO	Selects whether to make the rear earphone monaural or stereo.
07	AUDIO-2	AU DATA LEN (IMX) (PDW-530/530P only)	16 bit//24 bit	16bit	Sets the bit length of the digital audio recording.
		AU REF LEVEL	-20 dB/-18 dB/ -16 dB/-12 dB/ EBUL	-20 dB	Sets the reference level (Head Room).
		AU REF OUT	0 dB/+4 dB/-3 dB/ EBUL	0 dB	Sets the output reference level.
		AU CH12 AGC MODE	MONO/STREO	MONO	Selects whether to perform automatic input level adjustment of analog audio signals to be recorded on channels 1 and 2 independently for each channel, or in stereo mode.
		AU CH34 AGC MODE	OFF/MONO/ STREO	MONO	Selects whether to perform automatic input level adjustment of analog audio signals to be recorded on channels 3 and 4 independently for each channel, or in stereo mode, or not at all (OFF).
		AU AGC SPEC	-6/-9/-12/-15 dB	-6 dB	AGC saturation level setting
		AU LIMITER MODE	OFF/-6/-9/-12/-15 dB	OFF	For manual audio input level adjustment, selects the limiter saturation level for loud input signals.
		AU OUT LIMITER	OFF/ON	ON	Turns the audio output limiter on or off.
		i.LINK AUDIO OUT	2CH/4CH	2CH	2CH: Output channels 1 and 2 (16 bits, 48 ksp) 4CH: Output channels 1 to 4 (12 bits, 32 ksp)

No.	Page	Item	Settings	Default	Description
08	AUDIO-3	AU SG (1kHz)	ON/OFF/AUTO	OFF	Sets whether to output a 1 kHz test tone during the Color Bar mode or not. ON: a 1 kHz test tone is output during the Color Bar mode. OFF: a 1 kHz test tone is not output during the Color Bar mode. AUTO: a 1 kHz test tone is output only when the CH 1 AUDIO SELECT switch on the inside panel is in the AUTO position.
		MIC CH1 LEVEL	SIDE1/FRONT/ F+S1	FRONT	When recording the front microphone sound on CH 1, selects which control is to be used for the level adjustment. SIDE 1: Adjust it with the LEVEL control (left side) on the side panel. FRONT: Adjust it with the MIC LEVEL control on the front panel. F + S1: It can be adjusted using either the LEVEL control (left side) or the MIC LEVEL control. (The two controls are linked to each other.)
		MIC CH2 LEVEL	SIDE2/FRONT/ F+S2	FRONT	When recording the front microphone sound on CH 2, selects which control is to be used for the level adjustment. SIDE 2: Adjust it with the LEVEL control (right side) on the side panel. FRONT: Adjust it with the MIC LEVEL control on the front panel. F + S2: It can be adjusted using either the LEVEL control (right side) or the MIC LEVEL control. (The two controls are linked to each other.)
		REAR1/WRR LEVEL	SIDE1/FRONT/ F+S1	SIDE 1	Selects any of these controls to adjust the audio level of the equipment that is connected to the wireless microphone and whatever is connected to the AUDIO IN CH1 connector on the rear panel. SIDE 1: Adjust it with the LEVEL control (left side) on the side panel. FRONT: Adjust it with the MIC LEVEL control on the front panel. F + S1: It can be adjusted using either the LEVEL control (left side) or the MIC LEVEL control. (The two controls are linked to each other.)
		REAR2/WRR LEVEL	SIDE2/FRONT/ F+S2	SIDE 2	Selects any of these controls to adjust the audio level of the equipment that is connected to the wireless microphone and whatever is connected to the AUDIO IN CH2 connector on the rear panel. SIDE 2: Adjust it with the LEVEL control (right side) on the side panel. FRONT: Adjust it with the MIC LEVEL control on the front panel. F + S2: It can be adjusted using either the LEVEL control (right side) or the MIC LEVEL control. (The two controls are linked to each other.)

No.	Page	Item	Settings	Default	Description
09	TIMECODE	TC OUT	AUTO/GENE	AUTO	Selects the time code signal output. AUTO: Outputs the time code generator output during recording and outputs the time code reader output during playback. GENE: Outputs the time code generator output during recording and playback.
		DF/NDF (PDW-510/530 only)	DF/NDF	DF	Sets DF or NDF mode. DF: Drop frame mode NDF: Non-drop frame mode
		EXT-LK DF/NDF (PDW-510/530 only)	INT/EXT	INT	Selects either internal setting or external setting for DF/NDF. INT: Internal EXT: External
		EXT-LK UBIT	INT/EXT	INT	Sets whether the LTC UBIT setup value locks to an INT or an EXT source when the time code is locked to an external source. INT: Internal lock EXT: External lock
		LTC UBIT	FIX/TIME	FIX	Sets the data to be recorded in UBIT of LTC. FIX: Records the data that is set by the user. TIME: Records the present time.
		VITC UBIT	FIX/TIME	FIX	Sets the data to be recorded in UBIT of VITC. FIX: Records the data that is set by the user. TIME: Records the present time.
		WATCH AUTO ADJ	OFF/ON	ON	Matches the time of the built-in clock with the time data of the user bits of an external time code. Turns the automatic time correction function of the built-in clock on or off .
		UBIT GROUP ID	000/101	000	Selects the UBIT GROUP ID.
		VITC INS LINE 1	12 to 19 H (PDW-510/530)	16H	Selects the line into which VITC is to be inserted.
			9 to 22 H (PDW-510P/530P)	19h	
		VITC INS LINE 2	12 to 19 H (PDW-510/530)	18h	Selects the line into which VITC is to be inserted.
9 to 22 H (PDW-510P/530P)	21H				
10	VDR MODE	REC TALLY BLINK	OFF/ON	ON	Turns the tally illumination control on or off in the event of BATTERY BEFORE END/DISC BEFORE END.
		REC START BEEP	OFF/ON	OFF	Turns on or off the alarm sound at REC START/STOP.
		SUB LCD MODE SEL	TIMER/OFF/CONT	TIMER	Sets the time code (TC) display after power-off as follows. TIMER: The TC display turns off after the elapse of the time set by the SUB LCD TIMER below. OFF: Not displayed. CONT: Displayed.
		SUB LCD TIMER	1H/3H/8H	1H	Sets the duration of time after which the TC display is to be turned off after power-off, when the SUB LCD MODE SEL item, above, is set to TIMER (H: hours).
		REC FORMAT (PDW-530/530P only)	IMX50/IMX40/ IMX30/DVCAM	IMX50	Selects the type of video codec. Multiple codecs cannot be mixed on one disc.

No.	Page	Item	Settings	Default	Description
11	ESSENCE MARK	SHOT MARK 1	OFF/ON	OFF	See 3-2-3 "Recording Essence Marks" on page 43.
		SHOT MARK 2	OFF/ON	OFF	
		OVER AUDIO MARK	OFF/ON	OFF	
		GAIN CHG. MARK	OFF/ON	OFF	
		FILTER CHG. MARK	OFF/ON	OFF	
		SHUTTER CHG. MARK	OFF/ON	OFF	
		WHITE CHG. MARK	OFF/ON	OFF	
		FLASH MARK	OFF/ON	OFF	
		FLASH MARK LEVEL	1 to 20	10	
		INDEX PIC. POS.	0/1/2/3/4/5/6/7/8/9/10 SEC	0	See 5-7 "Setting the Thumbnail Image" on page 87.
12	PRESET WHT	COLOR TEMP. <P>	Display color temperature.	3200	White balance preset value
		COLOR FINE <P>	(-99 to +99)	0	—
		R GAIN <P>	(-99 to +99)	0	R gain preset value
		G GAIN <P>	(-99 to +99)	0	G gain preset value
		D5600 <P>	OFF/ON	OFF	Selects whether to electrically apply 5600K filter to white balance preset value.
		AWB ENABLE <P>	OFF/ON	OFF	Turns on and off the function which automatically acquires the preset value for automatic white balance adjustment.
13	DCC ADJUST	DCC FUNCTION SEL	DCC/Adaptive KNEE/FIX	DCC	Selects the function assigned to the DCC switch. ADP.K is Adaptive Knee and FIX is fixed value.
		DCC D RANGE	400/450/500/550/600%	600%	Sets the timing range when the DCC switch is set to the ON position.
		DCC POINT	(-99 to +99)	0	DCC minimum knee point adjustment
		DCC GAIN	(-99 to +99)	0	Gain adjustment to DCC detected value
		DCC DELAY TIME	(-99 to +99)	0	DCC reaction speed adjustment

No.	Page	Item	Settings	Default	Description
14	AUTO IRIS 2	IRIS WINDOW	1/2/3/4/5/6/VAR	1	Selects the auto iris detection window. VAR is variable.
		IRIS WINDOW IND	OFF/ON	OFF	Turns on and off the function which displays a frame marker for the auto iris detection window.
		IRIS LEVEL	(-99 to +99)	0	Level adjustment of the auto iris target value
		IRIS APL RATIO	(-99 to +99)	0	Mix ratio of auto iris detection peak value and average value
		IRIS VAR WIDTH	20 to 465	245	Width and height of detection frame when the auto iris detection window is set to VAR
		IRIS VAR HEIGHT	20 to 172	85/72	Height of detection frame when the auto iris detection window is set to VAR
		IRIS VAR H POS.	-447 to +446 (PDW-510/530)	0	Horizontal position of detection frame when the auto iris detection window is set to VAR
			-447 to +446 (PDW-510P/530P)	0	
		IRIS VAR V POS.	-104 to +104 (PDW-510/530)	0	Vertical position of detection frame when the auto iris detection window is set to VAR
			-124 to +123 (PDW-510P/530P)	0	
		IRIS SPEED	(-99 to +99)	0	Auto iris speed adjustment
CLIP HIGH LIGHT	OFF/ON	OFF	Turns on and off the function which, during auto iris adjustment, ignores very bright areas by dulling the reaction to high luminescence.		
15	FUNCTION 3	WHT FILTER INH	OFF/ON	OFF	Turns on and off the function which inhibits independent white memory for each filter position.
		COLOR BAR SEL	SMPTE/EBU/SNG	SMPTE (PDW-510/530)	Color bar type
				EBU (PDW-510P/530P)	
		REC TALLY	UPPER/BOTH	UPPER	Selects whether to light the upper tally indicator only, or both upper and lower tally indicators.
		COLOR VF INPUT	COMP/VBS/BOTH	COMP	Video input selection when a color viewfinder is used
		USER & ALL ONLY	OFF/ON	OFF	Show only USER menu in the top menu.
		RM COMMON MEMORY	OFF/ON	OFF	Selects whether or not to share settings for when an RM remote control unit is connected and when the unit is used alone.
		RM REC START/STOP	RM/CAM/PARA	RM	When an RM remote control unit is connected, selects which REC START/STOP buttons are enabled. RM/camera/both.
		SHT DISP MODE	SEC/DEG	SEC	Selects shutter speed display in standard mode.

No.	Page	Item	Settings	Default	Description
16	GENLOCK	GENLOCK	OFF/ON	ON	Turns genlock on and off.
		RETURN VIDEO	OFF/ON	OFF	Turns return video on and off.
		GL H PHASE	(-60 to +139) (PDW-510/530)	0	Genlock H phase setting.
			(-59 to +142) (PDW-510P/530P)	0	
		GL SC PHASE	(-99 to +99)	0	Genlock subcarrier phase setting
		GL SC 0/180 SEL	0/180	180	Genlock subcarrier phase setting
17	ND COMP (PDW-530/530P only)	ND OFFSET ADJUST	OFF/ON	—	Turns on and off the mode which sets ND (neutral density) filter color compensation values.
		CLEAR ND OFFSET	—	EXEC	Clears ND filter color compensation values.
18	AUTO SHADING	AUTO BLK SHADING	EXEC	EXEC	Execute the auto black shooting function.
		RESET BLK SHD	EXEC	EXEC	Clears black shooting compensation values.
		TEST OUT SELECT	ENC/R/G/B	ENC	Selects the signal output to the TEST OUT connector.
		MASTER GAIN (TMP)	-3/0/3/6/9/12/18/ 24/30/36/42/48 dB	0 dB	Temporarily sets the master gain value.
19	DISC	DELETE LAST CLIP	EXEC	EXEC	Delete the last clip.
		DELETE ALL CLIPS	EXEC	EXEC	Delete all clips on the disc.
		QUICK FORMAT	EXEC	EXEC	Formats the disc. All the recorded data is deleted.
20	NETWORK	DHCP	ENABL/DSABL	DSABL	Selects whether to enable automatic acquisition of the IP address from a DHCP server.
		IP ADDRESS	xxx.xxx.xxx.xxx	192.168.1 .10	Sets the IP address.
		SUBNET MASK	xxx.xxx.xxx.xxx	255.255.2 55.0	Sets the subnet mask.
		DEF. GATEWAY	xxx.xxx.xxx.xxx	0.0.0.0	Sets the default gateway.
		LINK SPEED	AUTO/10 Mbps/ 100 Mbps	AUTO	Sets the communications speed.
		DUPLEX	AUTO/FULL/HALF	AUTO	Sets the duplex mode.

- 1) The setting of this item is overridden by the setting of BEFORE END 3 when TYPE DETECTION in the BATTERY 2 page is set to OTHER.
- 2) The setting of this item is overridden by the setting of END 3 when TYPE DETECTION in the BATTERY 2 page is set to OTHER.
- 3) When TYPE DETECTION in the BATTERY 2 page is set to AUTO, any batteries other than Sony BP-series batteries and Anton Bauer intelligent battery systems are classified as "Others".
- 4) Flashes once per second when the battery status is "BEFORE END", and flashes 4 times per second when the battery status is "END".

FILE Menu List

The following table lists and describes the items in the FILE menu.

When the setting range in the Settings column is surrounded by parentheses (), the setup value is a relative

value. The setting range shown on the menu screen may differ from what is shown in the manual.

No.	Page	Item	Settings	Default	Description
01	USER FILE	USER FILE LOAD	—	EXEC	See 8-1 “Saving and Loading User Files to and from a “Memory Stick”” on page 131.
		USER FILE SAVE	—	EXEC	
		F. ID	16 characters	—	
		USER PRESET	—	EXEC	See 7-4 “Resetting USER Menu Settings to the Standard Settings” on page 130.
02	USER FILE2	STORE USR PRESET	—	EXEC	Sets the pages registered in the USER menu to the standard setting.
		CLEAR USR PRESET	—	EXEC	Clears the standard setting of pages registered in the USER menu.
		CUSTOMIZE RESET	—	EXEC	Returns the pages registered in the USER menu to the factory default state.
		LOAD CUSTOM DATA	OFF/ON	OFF	Selects whether to include pages registered by the user in user files to be loaded by USER FILE LOAD.
		LOAD OUT OF USER	OFF/ON	OFF	Selects whether to include pages not registered by the user in user files loaded by USER FILE LOAD.
		BEFORE FILE PAGE	OFF/ON	OFF	Selects whether to include data after USER FILE pages in user files to be loaded by USER FILE LOAD.
		USER LOAD WHITE	OFF/ON	OFF	Selects whether to include white balance data in user files to be loaded by USER FILE LOAD.
03	ALL FILE	ALL FILE LOAD	—	EXEC	Load ALL file.
		ALL FILE SAVE	—	EXEC	Save ALL file.
		F. ID	16 characters	—	Name ALL file.
		ALL PRESET	—	EXEC	Return items in ALL file to preset values.
		STORE ALL PRESET	—	EXEC	Set preset values of items in ALL file.
		CLEAR ALL PRESET	—	EXEC	Clear preset values of items in ALL file.
		3SEC CLR PRESET	OFF/ON	OFF	Turns on and off the function which returns menu items to the preset values when the MENU knob is kept pressed for 3 seconds.
		NETWORK DATA	OFF/ON	OFF	Selects whether or not to read in the network-related data.
04	SCENE FILE	1	—	—	See 8-2 “Saving and Loading Scene Files” on page 136.
		2	—	—	
		3	—	—	
		4	—	—	
		5	—	—	
		STANDARD	—	—	
		SCENE RECALL	—	EXEC	
		SCENE STORE	—	EXEC	
		F. ID	16 characters	—	

No.	Page	Item	Settings	Default	Description
05	REFERENCE	REFERENCE STORE	—	EXEC	Save reference file in internal memory.
		REFERENCE CLEAR	—	EXEC	Clear reference file.
		REFERENCE LOAD	—	EXEC	Load reference file.
		REFERENCE SAVE	—	EXEC	Save reference file to “Memory Stick”.
		F. ID	16 characters	—	Name reference file.
		SCENE WHITE DATA	OFF/ON	OFF	see “White balance setting data to be saved in the scene file” on page 137.
06	LENS FILE 1	LENS FILE RECALL	—	EXEC	Load lens file.
		LENS FILE STORE	—	EXEC	Save lens file.
		F. ID	16 characters	—	Name of selected lens file
		SOURCE	—	MEMORY1	Number of selected lens file
		LENS NO OFFSET	—	—	Clear lens file.
		IRIS GAIN	—	0	Iris gain value of lens file
		LENS AUTO RECALL	ON/OFF	ON	When a serial lens is connected with this item set to ON, the corresponding lens file is loaded automatically and its content is reflected in the lens settings.
		L.ID	—	—	Name of the lens file corresponding to the connected serial lens
		L.MF	—	—	Manufacturer of the connected serial lens
07	LENS FILE 2	LENS M VMOD ¹⁾	(-99 to +99)	0	Lens file V Saw seed
		LENS CENTER H ¹⁾	-466 to +465	0	Horizontal position compensation of lens file center marker
		LENS CENTER V ¹⁾	-121 to +120	0	Vertical position compensation of lens file center marker
		TEST OUT SELECT	ENC/R/G/B	ENC	Selects signal output to TEST OUT connector.
		LENS R FLARE ¹⁾	(-99 to +99)	0	Adjustment of lens file flare (R)
		LENS G FLARE ¹⁾	(-99 to +99)	0	Adjustment of lens file flare (G)
		LENS B FLARE ¹⁾	(-99 to +99)	0	Adjustment of lens file flare (B)
		LENS W-R OFST ¹⁾	(-99 to +99)	0	R compensation value when extender and shrinker used.
		LENS W-B OFST ¹⁾	(-99 to +99)	0	B compensation value when extender and shrinker used.
08	LENS FILE 3	SHADING CH SEL	R/G/B/TEST	R	Selects the channel adjusted by this menu. If TEST is selected, the setting is the same as the setting of TEST OUT SELECT.
		TEST OUT SELECT	ENC/R/G/B	ENC	Selects the signal output to the TEST OUT connector.
		LENS R/G/B H SAW ¹⁾	(-99 to +99)	0	H Saw white shading compensation
		LENS R/G/B H PARA ¹⁾	(-99 to +99)	0	H Parabola white shading compensation
		LENS R/G/B V SAW ¹⁾	(-99 to +99)	0	V Saw white shading compensation
		LENS R/G/B V PARA ¹⁾	(-99 to +99)	0	V Parabola white shading compensation
09	MEMORY STICK	FORMAT	—	—	Format “Memory Stick”.
		MS IN > JUMP TO	OFF/USER/ ALL/SCENE/ LENS/REFER/ USER1	—	See 8-3 “Jumping to a File-Related Menu Page When Inserting a “Memory Stick”” on page 140.

1) “EX” is displayed when the extender is on, and “0.8” is displayed when the shrinker is on.

DIAGNOSIS Menu List

The following table lists and describes the items in the DIAGNOSIS menu.

No.	Page	Item	Description
01	HOURS METER	OPERATION	Displays the total time that this unit has been powered on, in units of hours.
		OPERATION (rst)	Displays the total time that this unit has been powered on, in units of hours (reset possible).
		SPINDLE (rst)	Displays the total time that the spindle has been rotating, in units of hours (reset possible).
		LASER (rst)	Displays the total number of output parameters to the optical heads (reset possible).
		LOADING (rst)	Displays the number of times that discs have been loaded (reset possible).
		SEEK (rst)	Displays the total seek time by the optical heads, in units of hours (reset possible).
02	TIME/DATE	ADJUST	<i>See 7-3-6 "Setting the Date/Time of the Internal Clock" on page 122.</i>
		HOUR	
		MIN	
		SEC	
		YEAR	
		MONTH	
		DAY	
03	ROM VERSION 1	AT	Displays ROM version.
		PACKAGE	
04	ROM VERSION 2	SY1: Ver X.XX	
		PIER: Ver X.XX	
		VAIN: Ver X.XX	
		SYS2K: Ver X.XX	
		SYS2U: Ver X.XX	
		DRIVE: Ver X.XX	
		FP: Ver X.XX	
		DSPA: Ver X.XX	
		PRX.A: Ver X.XX	
		PRX.V: Ver X.XX	
05	DEV STATUS	I/O EEPROM LSI	Display only.
		IFA : CN: PX:	
		FP : DCP: BCS:	
		CN : PA:	
		FRAM SCI	
		AT: SS:	
		RM:	

No.	Page	Item	Description
07	DISC STATUS	USER ID:	Displays the user ID of the disc itself.
		TITLE:	Displays the title of the disc itself.
		REMAIN	Displays the remaining capacity of the disc.
		REWRITE	Displays the number of times the disc has been rewritten.
		SALVAGE	Displays "required" when salvage is required.
		FILE SYSTEM: UDF2.5	Displays "unknown" when the file system cannot be identified, or when there is an error.
08	CLIP STATUS	CLIP LIST MODE	NORMAL MODE or CLIP LIST MODE
		CURRENT ID	NORMAL MODE: Number of current clip, total number of clips CLIP LIST MODE: Clip list number
		TITLE	NORMAL MODE: Title of current clip CLIP LIST MODE: Title of clip list
		RECORD DEVIDE	NORMAL MODE: Name of device which recorded current clip CLIP LIST MODE: Displays "-----".
		SERIAL	NORMAL MODE: Serial number of device which recorded current clip CLIP LIST MODE: Displays "-----".
		DATE	NORMAL MODE: Date when current clip was recorded CLIP LIST MODE: Date when clip list was created
		TIME	NORMAL MODE: Time when current clip was recorded CLIP LIST MODE: Time when clip list was created
09	OPTION BOARD	SDI OUTPUT	Displays installed options.
		COMPOSITE VIDEO INPUT	
		PULL DOWN (24P)	

About a “Memory Stick”

What is “Memory Stick”?

“Memory Stick” is a new compact, portable and versatile IC (Integrated Circuit) recording medium with a data capacity that exceeds a floppy disk. “Memory Stick” is specially designed for exchanging and sharing digital data among “Memory Stick” compatible products. Because it is removable, “Memory Stick” can also be used for external data storage.

“Memory Stick” is available in two sizes: standard size and compact “Memory Stick Duo” size. Once attached to a “Memory Stick Duo” adapter, “Memory Stick Duo” turns to the same size as standard “Memory Stick” and thus can be used with products compliant with standard “Memory Stick”.

Types of “Memory Stick”

“Memory Stick” is available in the following four types to meet various requirements in functions.

“Memory Stick-R”

Stored data are not overwritten. You can write data to “Memory Stick-R” with “Memory Stick-R” compatible products only. Copyright protected data that requires MagicGate copyright protection technology cannot be written to “Memory Stick-R.”

“Memory Stick”

Stores any type of data except copyright-protected data that requires the MagicGate copyright protection technology.

“MagicGate Memory Stick”

Equipped with the MagicGate copyright protection technology.

“Memory Stick-ROM”

Stores pre-recorded, read-only data. You cannot record on “Memory Stick-ROM” or erase the pre-recorded data.

Available types of “Memory Stick”

You can use a “Memory Stick” and a “MagicGate Memory Stick” with your product.

Note

You can not use a “Memory Stick Duo” with your product.

Note on data read/write speed

Data read/write speed may vary depending on the combination of the “Memory Stick” and “Memory Stick” compliant product you use.

What is MagicGate ?

MagicGate is copyright protection technology that uses encryption technology.

Before using a “Memory Stick”

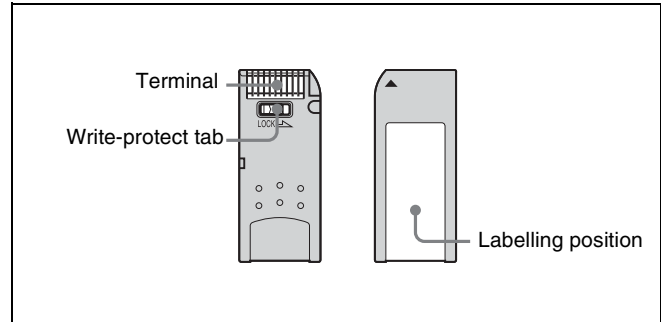

- When you set the “Memory Stick” erasure prevention switch to “LOCK,” data cannot be recorded, edited, or erased.
- Data may be damaged if:
 - You remove the “Memory Stick” or turn off the unit while it is reading or writing data.
 - You use the “Memory Stick” in a location subject to the effects of static electricity or electric noise.
- We recommend that you make a backup copy of important data that you record on the “Memory Stick”.

Notes

- Do not attach anything other than the supplied label to the “Memory Stick” labeling position.
- Attach the label so that it does not stick out beyond the labeling position.
- Carry and store the “Memory Stick” in its case.
- Do not touch the connector of the “Memory Stick” with anything, including your finger or metallic objects.
- Do not strike, bend, or drop the “Memory Stick”.
- Do not disassemble or modify the “Memory Stick”.
- Do not allow the “Memory Stick” to get wet.
- Do not use or store the “Memory Stick” in a location that is:
 - Extremely hot, such as in a car parked in the sun
 - Under direct sunlight
 - Very humid or subject to corrosive substances

“Memory Stick” Access Indicator

If the access indicator is turned on or is flashing, data is being read from or written to the “Memory Stick”. At this time, do not shake the computer or product or subject them to shock. Do not turn off the power of the computer and product or remove the “Memory Stick”. This may damage the data.

Precautions

- To prevent data loss, make backups of data frequently. In no event will Sony be liable for any loss of data.
- Unauthorized recording may be contrary to the provisions of copyright law. When you use a “Memory Stick” that has been pre-recorded, be sure that the material has been recorded in accordance with copyright and other applicable laws.
- The “Memory Stick” application software may be modified or changed by Sony without prior notice.
- Note that there are certain restrictions on recording stage performances and other entertainment events, even if they are recorded for personal use only.

- “Memory Stick”,  and “MagicGate Memory Stick” are trademarks of Sony Corporation.
- “Memory Stick Duo” and **MEMORY STICK DUO** are trademarks of Sony Corporation.
- “Memory Stick PRO” and **MEMORY STICK PRO** are trademarks of Sony Corporation.
- “MagicGate” and **MAGICGATE** are trademarks of Sony Corporation.

Glossary

AES/EBU

A standard established jointly by the AES (Audio Engineering Society) and EBU (European Broadcasting Union) for serial transmission of digital audio. Two channels of audio can be transmitted via a single connector.

Aliasing

Distortion which occurs during sampling to convert analog signals to digital.

ATW

Auto Tracing White balance. The white balance is automatically adjusted for the lighting conditions during shooting.

Bayonet mount

A type of lens mount. The lens can be inserted into the lens mount and quickly locked in place by simply rotating the lens locking ring.

Black balance adjustment

To balance the black levels of the R, G, and B channels of a video camera so that black has no color.

Black set

A reference level for black balance adjustment.

CCD

Charge-Coupled Device. A solid state imager used in most video cameras in place of a pickup tube. The device converts input light levels into electrical charges that are first stored and then output in the form of voltage variations.

Center marker

A cross which indicates the center of the image on the viewfinder screen.

Clip

A recording unit. Clips are created every time recording starts and stops.

Clip list

A list of locations in the material recorded on the disc, arranged in any order. Clips lists can be created with

the scene selection function of this unit, and with the supplied PDZ-1 Proxy Browsing Software.

Color bar signal

A test signal which can be displayed as vertical bars of different colors on a color video monitor. This signal is used to check chrominance functions of color television and video systems such as cameras and monitors.

Color subcarrier

In a composite video signal, a signal superimposed upon the picture (luminance) information for the purpose of conveying the associated color information. Color and saturation information is conveyed by the phase and amplitude of the color subcarrier. Also called subcarrier.

Color temperature

The temperature in Kelvins (K) to represent the color of a light source, determined by heating a perfectly black body until its color matches that of the light source. Color temperature is higher when the color is bluish and lower when reddish.

Composite video signal

A video signal in which luminance and chrominance are combined along with timing reference "sync" information to make composite video.

CRT

Cathode-Ray Tube. Video camera viewfinders are equipped with a CRT image display, so you can monitor what you are shooting.

DCC

Dynamic Contrast Control. A DCC circuit automatically adjusts the knee point according to the amount of incident light. A video camera containing a DCC circuit can handle a wide dynamic range of luminance.

Drop frame mode

SMPTE time code runs at 30 frames/second, while the NTSC color television system runs at about 29.97 frames/second. Drop frame mode adjusts the running of time code to eliminate the discrepancy between

time code value and actual time by dropping two frames from the time code value at the beginning of each minute except every tenth minute.

E-E mode

Electric-to-Electric mode. When you operate a VDR in E-E mode, input video and/or audio signals pass through electric circuits only and then come out from the output connectors, without passing through electromagnetic conversion circuits such as recording heads.

EFF

Electronic Field Production. The use of electronic equipment such as portable video cameras, VTRs, and sound equipment for television production outside studios.

ENG

Electronic News Gathering. The use of electronic equipment such as portable video cameras, VTRs, and sound equipment for the production of daily news stories and short documentaries.

Essence mark

A type of metadata that may be set for a specified frame.

Flare

Dark or colored flashes caused by signal overload through extreme light reflections of polished objects or very bright lights.

Flange focal length

The distance from the plane of lens mounting flange to the image focal plane. Abbreviated to Ff.

Flicker

Repeated change of brightness on the screen, caused by light sources such as fluorescent light flashing at the frequency of alternating current.

Genlock

Generator lock. To synchronize the pulse generator built into video equipment to an external reference (master) sync signal.

HAD

Hole-Accumulated Diode. A CCD sensor structure designed to suppress

certain types of noise inherent to CCDs. See also CCD.

Hunting

Repeated brightening and darkening of an image resulting from repeated response to automatic iris control.

i.LINK

Another name for the IEEE1394-1995 standards and their revisions. XDCAM uses the i.LINK interface to transfer DV streams by the AV/C protocol, and to read and write MPEG IMX and DVCAM data files by FAM (File Access Mode).

Interlaced scan mode (CCD output)

A scanning method in which odd rows fields are read alternately with even rows. (Odd-row fields and even-row fields contain images from different times.)

IRE scale

International Radio Engineers scale. A scale of values that defines the brightness level of a video signal. The IRE is now the IEEE (Institute of Electrical and Electronic Engineers).

Metadata

Information about the properties of video and audio content. XDCAM records metadata such as UMIDs and essence marks, and the supplied PDZ-1 Proxy Browsing Software PDZ-1 can be used to record information such as titles and comments.

MXF

Material eXchange Format. A file exchange format developed by the Pro-MPEG Forum. Equipment from different manufacturers can exchange files in this format.

ND filter

Neutral Density filter. ND filters reduce the amount of incident light equally across the entire visible wavelength range without affecting color.

Non-audio

General term for audio signals other than linear PCM, such as Dolby E and Dolby Digital (AC-3).¹⁾

XDCAM can record non-audio as an input signal.

1) Dolby is a trademark of Dolby Laboratories.

Non-drop frame mode

A mode of advancing time code which ignores the difference in frame values between real time and the time code. Using this mode produces a difference of approximately 86 seconds per day between real time and time code, which causes problems when editing programs in units of seconds using the number of frames as a reference.

Progressive scan mode (CCD output)

A scanning method in which odd rows and even rows are read at the same time. Also called full-screen scanning.

Proxy AV data

Low-resolution data with a video bandwidth of 1.5 Mbps and an audio bandwidth of 64 Kbps per channel. This unit records proxy AV data automatically whenever high-resolution MPEG IMX or DVCAM data is recorded.

Reference video signal

A video signal that contains a sync signal or sync and burst signals, used as a reference for synchronization of video equipment.

Return video

A video signal returned to a camera from a VTR, or a video signal selected from among several camera angles in a control room and returned to a camera so the cameraman can check the video.

SDI

Serial Digital Interface. An interface standardized as SMPTE 259M which enables the transmission of an uncompressed digital component stream.

Shot data

Data recorded, while shooting, in the color bars, the user bits data of VITC, and so forth. Includes the model name, serial number, date, time, shot number, and ID1 to ID4.

Shutter speed

The time that the shutter is open. Slow shutter speeds give bright images, but motion resolution is lower.

SMPTE

Society of Motion Picture and Television Engineers, a professional association established in the U.S.A. mainly for the purpose of setting forth motion picture and television engineering standards.

S/N

Signal-to-Noise ratio. The relation of the strength of the desired signal to the accompanying electronic interference, the noise. If S/N is high, sounds are reproduced with less noise and pictures are reproduced clearly without snow.

SNMP

Simple Network Management Protocol. XDCAM uses this protocol to monitor equipment operating status via network connectors.

Sub clip

One of the sections which make up a clip list. A sub clip may be part of a clip or an entire clip.

Thumbnail image

A reduced still picture of video for display on a GUI screen. XDCAM creates thumbnail images from proxy video, and displays them as index pictures on GUI screens.

Time code

A digitally encoded signal which is recorded with video data to identify each frame of the video by hour, minute, second and frame number. SMPTE time code is applied to NTSC system, and EBU time code to PAL and SECAM systems.

Time code synchronization

To synchronize the built-in time code generator of video equipment to an external time code.

Turbo gain

Video amplifier gain increased from 30 dB by 6 to 18 dB by combining adjacent pixels of the CCD.

UMID

Unique Material Identifier. A standard (SMPTE 330M) for video and audio metadata. The Basic section of a UMID contains a globally unique number and a material number for the identification of recorded material. An optional section called the “Source Pack” contains information such as the time and location of recording. A UMID with the Basic section only is called a Basic UMID. A UMID with the Source Pack is called an Extended UMID.

User bits

A total of 32 bits are provided in the time code which the user can use to record such information as date, scene number, or reel number on video tape. Also called user’s bits.

VBS

A composite signal consisting of video signal, burst signal and sync signal.

Vertical smear

A bright vertical line which appears on the screen when shooting a very bright object with a CCD camera. Also called smear.

Video gain

Amount of amplification for video signals, expressed in decibels (dB).

VITC

Vertical Interval Time Code. A time code recorded in two horizontal lines during each vertical blanking period of a video signal.

White balance adjustment

In the light of a particular color temperature, to adjust the white levels of the R, G, and B channels of a color video camera so that any white object shot in that light is reproduced as a truly white image. See also Color temperature.

White shading

When shooting a white object, the upper and lower portions of the screen may appear magenta or green while the central portion appears white, depending on the performance

of the camera lens. This is called white shading.

Zebra pattern

In a video camera, striped patterns which appear in the viewfinder screen to indicate areas of the image where the video level is higher than a certain value. If a zebra pattern appears on the skin when the object is a human being, that is a correct exposure.

Zoom

To gradually change the field of view of a camera lens from wide to narrow angle (zoom in) or narrow to wide angle (zoom out).

Index

A

AC adaptor 143
 ACCESS indicator 32
 Access indicator (for "Memory Stick")
 28
 Accessory attachments 15
 Adjusting
 audio level 81
 black balance 72
 flange focal length 148
 shoulder pad position 154
 viewfinder 144
 white balance 73
 Adjustments and settings
 for recording 70
 from menus 117
 ALARM volume control 17
 ALL FILE page 189
 Anton Bauer Ultralight system 143
 Aspect ratio, selecting 123
 ASSIGN 1/2 switches 21
 ASSIGN 3/4 switches 22
 Assigning functions to ASSIGN 1/2/3/
 4 switches 120
 Attaching the shoulder strap 154
 Audio functions 16
 AUDIO IN CH1/CH2 connectors 18
 AUDIO IN CH-1/CH-2 switches 18
 AUDIO IN CH-3/CH-4 switches 18
 Audio input system 148
 attaching a UHF portable tuner
 150
 connecting line input audio
 equipment 152
 using an external microphone 149
 using the supplied microphone
 148
 Audio level meters 34
 AUDIO OUT connector 18
 Audio recording level 81
 adjustment for input from the front
 microphone 82
 adjustment for inputs from the
 AUDIO IN CH1/CH2
 connectors 81
 AUDIO SELECT CH-1/CH-2
 switches 18
 AUDIO-1 page 183
 AUDIO-2 page 183
 AUDIO-3 page 184
 Auto clip list recoding 53
 Auto Interval Rec mode 47
 AUTO IRIS 2 page 187

AUTO IRIS page 173
 AUTO SHADING page 188
 AUTO W/B BAL switch 21

B

Back tally indicator 31
 Back tally ON/OFF switch 32
 Basic procedures
 for recording 41
 for shooting 41
 BATTERY 1 page 181
 BATTERY 2 page 182
 Battery attachment 13
 Battery pack 142
 attaching 142
 BP-GL95 142
 BP-IL75 142
 BP-M100 142
 detaching 143
 Battery status
 on the color LCD 34
 on the monochrome LCD 33
 BKW-401 Viewfinder Rotation
 Bracket 145
 Black balance
 adjusting 72
 basic procedure for shooting 41
 BLACK/FLARE page 175
 BLK GAMMA page 176
 BLK SHADING page 180
 BP-GL95 142
 BP-IL75 142
 BP-M100 142
 BRIGHT control 19
 Built-in speaker 17

C

CANCEL/PRST / ESCAPE switch 27
 CBK-FC01 8
 CBK-NC01 Network Adaptor 9
 CBK-SC01 10, 59
 CBK-SD01 10
 CCD scan mode 124
 CH-1/2 / CH-3/4 switch 16
 Checking
 the last two seconds of the
 recording 55
 the recording 54
 the recording on the color video
 monitor 55
 Clip list 61
 creating 62
 current clip list 61
 deleting 67
 editing 63
 loading 67

operation 66
 playback 57
 CLIP menu 66
 Color LCD 32
 Command List 95
 CONTRAST control 19
 Current clip list 61
 clearing 68
 saving to disc 66
 start timecode 68

D

DC IN connector 13
 DC OUT 12 connector 18
 DCC ADJUST page 186
 Deleting clips 43
 all clips 43
 the last clip 43
 DETAIL 1 page 176
 DETAIL 2 page 177
 DETAIL 3 page 177
 DEV STATUS-1 page 191
 DIAGNOSIS menu list 191
 Diopter adjustment ring 20
 Directory structure 88
 Disc
 formatting 39
 handling 37
 Loading and unloading 38
 notes on handling 37
 used for recording and playback
 37
 write-protecting 37
 DISC page 188
 Disc status
 display on the color LCD 34
 display on the monochrome LCD
 33
 DISP SEL switch 32
 DISPLAY switch 30, 31

E

EARPHONE jack 16
 EJECT button and indicator 24
 Essence mark 43
 thumbnail 56
 ESSENCE MARK page 186
 Example of system configuration 11

F

F FWD button and indicator 24
 F REV button and indicator 24
 FAM 91
 Features 7
 File access mode 91
 File ID

scene file 138
 user file 133
 FILE menu list 189
 File operation 88
 restriction 89
 FILTER selector 20
 Flange focal length, adjusting 148
 FORMAT page 174
 Formatting a disc 39
 F-RUN/SET/R-RUN switch 30
 FTP 93
 Full salvage 40
 FUNCTION 1 page 170
 FUNCTION 2 page 171
 FUNCTION 3 page 187

G

GAIN selector 21
 GAIN SW page 172
 GAMMA page 176
 GENLOCK IN connector 23, 29
 GENLOCK page 188

H

HOLD button 30
 HOURS METER 2 page 191

I

i.LINK DV IN/OUT S400 connector 23
 Indicators in the viewfinder 35
 Interval Rec function 47
 auto 47
 manual 50
 IP address 128

K

KNEE page 176

L

LCD switch 32
 '!LED page 172
 LENS connector 15
 LENS FILE 1 page 190
 LENS FILE 2 page 190
 LENS FILE 3 page 190
 LENS FILE page 173
 Lens locking lever 15
 Lens mount 15
 Lens mount cap 15
 Lens, mounting 147
 LEVEL ADJ page 180
 LEVEL controls 17
 LIGHT connector 15

Light shoe 15
 LIGHT switch 13
 Loading
 scene files 138
 user files from a "Memory Stick" 131
 Loading and unloading a disc 38
 Locations and functions of parts and controls 13
 LOCK knob 20
 LOW KEY SAT. page 179

M

Maintenance 157, 161
 Manual Interval Rec mode 50
 MARKER 1 page 172
 MARKER 2 page 172
 "Memory Stick"
 jumping to a file-related menu page 140
 about a "Memory Stick" 193
 compartment 28
 handling 131
 loading saved data 134
 saving and loading user files 131
 saving user menu data 132
 MEMORY STICK page 190
 Menu 100
 assigning functions to ASSIGN 1/2/3/4 switches 120
 basic operations 101
 displaying 101
 operating section 27
 organization 100
 resetting USER menu settings 130
 selecting the aspect ratio 123
 selecting the output signals 117
 setting gain values 117
 setting the CCD scan mode 124
 setting the color temperature manually 118
 specifying an offset for the auto white balance setting 119
 MENU knob 27
 Menu list 168
 MENU ON/OFF switch 27
 MIC IN connector 16
 MIC LEVEL control 16
 Microphone 16
 UHF portable tuner for wireless system 150
 using an external microphone 149
 using the supplied microphone 148
 MONITOR switch 16

MONITOR volume control 17
 Monochrome LCD 32, 33
 MTX LINEAR page 178
 MTX MULTI page 178

N

ND COMP page 188
 Network connector 10
 Network setting 128
 NEXT button 24

O

OFFSET WHT page 173
 OPERATION menu list 168
 Operation warnings 162
 Optical disc drive section, specifications 166
 Optional board
 CBK-FC01 8
 CBK-SC01 10, 59
 CBK-SD01 10
 OUTPUT page 168
 Output video operating section 26
 OUTPUT/DCC selector 21

P

PAINT menu list 175
 PDZ-1 69
 installation 69
 system requirements 69
 PEAKING control 19
 Picture Cache function 45
 PLAY/PAUSE button and indicator 24
 Playback 54
 freezing a picture 60
 in color 55
 +48V/OFF switch 18
 Power supply 13, 142
 using a battery pack 142
 using an AC adaptor 143
 using the Anton Bauer Ultralight system 143
 POWER switch 13
 Precautions 12
 PRESET WHT page 186
 PRESET/REGEN/CLOCK switch 30
 PREV button 25
 Proxy AV data 9
 Proxy Browsing Software (See also "PDZ-1") 69

Q

Quick salvage 40

R

- Rear tally indicator 32
- REC START button 24
- REC TIME 49
- Recommended additional equipment 167
- Recording 41
 - adjustments and settings 70
 - analog composite signals 59
 - setting the recording format 70
 - video signals from external equipment 58
- Recording and playback 37
- Recording format
 - setting the audio recording format 71
 - setting the video recording format 70
- Recording review 55
- REFERENCE page 190
- REMOTE connector 23
- Remote control unit, connecting 155
- RESET button 30
- Resetting USER menu settings to the standard settings 130
- Retaking 52
- Return video signal 116
- RM-B150/B750 155
- ROM VERSION 2 page 191
- ROM VERSION page 191

S

- Salvage function 39
- Saving and loading
 - scene files 136
 - user files to and from a “Memory Stick” 131
 - user setting data 131
- Scene file
 - loading 138
 - resetting the settings to the standard settings 139
 - saving and loading 136
- SCENE FILE page 179, 189
- Scene selection 61
- SEL/SET dial 26
- Selecting
 - aspect ratio 123
 - shutter mode 76
 - shutter speed 76
- SET STATUS page 173
- Setting
 - CCD scan mode 124
 - date/time of the internal clock 122
 - recording format 70

- time data 84
 - Setting up the camcorder 142
 - SHIFT button 26
 - Shooting
 - basic procedure (from adjusting the black balance and white balance to stopping recording) 41
 - basic procedure (from turning on the camcorder to loading a disc) 41
 - testing the camcorder before shooting 157
 - Shooting and recording/playback functions 19
 - SHOT DISP page 173
 - Shot ID 113
 - SHOT ID page 173
 - Shoulder pad 15
 - Shoulder pad, adjusting the position 154
 - Shoulder strap posts 15
 - Shoulder strap, attaching 154
 - SHT ENABLE page 173
 - Shutter mode, selecting 76
 - SHUTTER selector 21
 - Shutter speed, selecting 76
 - SKIN DETAIL page 177
 - SNMP 10
 - SOURCE SEL page 174
 - Specifications 165
 - Status display on the viewfinder screen 107
 - Status indicators 34
 - STATUS ON/SEL / OFF switch 27
 - STOP button 24
 - Sub clip 61
 - deleting 65
 - moving 64
 - trimming 65
 - SUB CLIP button 26
 - Sub clip indicator 26
 - SW STATUS page 175
- T**
- TAKE TOTAL TIME 49
 - Tally indicator 19, 31
 - TALLY switch 19, 31
 - TC IN connector 29
 - TC OUT connector 29
 - TEST OUT connector 23
 - TEST OUT page 169
 - Testing
 - Camera 157
 - preparations 157
 - VDR 158
 - THUMBNAIL button 26

- Thumbnail indicator 26
- Thumbnail search 55
- Time code
 - saving the actual time 84
 - setting 84
 - setting the user bits 84
 - synchronizing 85
 - system 29
- Time code display
 - on the color LCD 35
 - on the monochrome LCD 33
- TIME/DATE page 191
- TIMECODE page 185
- Time-lapse video 47
- Tripod mount 15
- Tripod mounting 153
- TURBO GAIN button 22
- 24P mode 125

U

- UMID data 126
- User bits, setting 84
- USER FILE page 189
- USER FILE2 page 189
- USER menu
 - editing 103
 - resetting 130

V

- V MODULATION page 178
- VDR MODE page 185
- VDR operation status 34
- VDR SAVE/STBY switch 24
- VF DISP 1 page 171
- VF DISP 2 page 171
- VF SETTING page 172
- Video camera section, specifications 165
- VIDEO OUT connector 23
- Viewfinder 20
 - adjusting the focus and screen 144
 - adjusting the position 144
 - cleaning 161
 - detaching 145
 - detaching the eyepiece 146
 - moving the viewfinder shoe up 145
 - setting 111
 - using the BKW-401 Viewfinder Rotation Bracket 145
- Viewfinder front-rear positioning lever 20
- Viewfinder screen
 - display modes 110
 - layout of the status display 107

- marker display 111
- return video signal 116
- selecting the display items 109
- Shot data superimposed on the
 - color bars 112
- shot ID 113
- Status confirmation windows 114
- status display 107

W

- WARNING indicator 32
- Warnings 162
- Warnings and indications 31
- Warnings and indications on the LCDs
 - 33
- WHITE BAL switch 22
- White balance
 - adjusting 73
 - basic procedure for shooting 41
 - specifying an offset for the auto
 - white balance 119
- WHITE page 175
- WHT SHADING page 180
- Write-protecting discs 37

Z

- ZEBRA switch 19



The material contained in this manual consists of information that is the property of Sony Corporation and is intended solely for use by the purchasers of the equipment described in this manual.

Sony Corporation expressly prohibits the duplication of any portion of this manual or the use thereof for any purpose other than the operation or maintenance of the equipment described in this manual without the express written permission of Sony Corporation.

PDW-510/510P/530/530P
(SYL)
3-805-941-05 (1)

Sony Corporation

<http://www.sony.net/>

© 2004