

Professional Disc Camcorder

Operating Instructions

Before operating the unit, please read this manual thoroughly and retain it for future reference.



PDW-F335L
PDW-F335K

Owner's Record

The model and serial numbers are located on the top. Record these numbers in the spaces provided below. Refer to them whenever you call upon your Sony dealer regarding this product.

Model No. _____ Serial No. _____

WARNING

To reduce the risk of fire or electric shock, do not expose this apparatus to rain or moisture.

To avoid electrical shock, do not open the cabinet. Refer servicing to qualified personnel only.



This Professional Disc Camcorder is classified as a CLASS 1 LASER PRODUCT.

Laser diode properties

Wavelength: 400 to 410 nm
Emission duration: Continuous
Laser output power: 135 mW (max. of pulse peak), 65 mW (max. of CW)
Standard: IEC60825-1 (2001)

Tekniska data för laserdiod

Våglängd: 400 till 410 nm
Emissionslängd: Kontinuerlig
Laserut effekt: 135 mW (max. för pulstopp), 65 mW (max. för kontinuerlig våg)
Standard: IEC60825-1 (2001)

Egenskaber for laserdiod

Bølgelængde: 400 til 410 nm
Strålingsvarighed: Kontinuerlig
Afgivet lasereffekt: 135 mW (maks stråletoppunkt), 65 mW (maks ved kontinuerlig stråling)
Standard: IEC60825-1 (2001)

Laserdiodin ominaisuudet

Aallonpituus: 400 - 410 nm
Säteilyn kesto: jatkuva
Laserin teho: 135 mW (pulssin huipun maks.), 65 mW (jatkuvan aallon maks.)
Standardi: IEC60825-1 (2001)



This label is located inside the outside panel of the unit.

Denna etikett finns på apparatens ovansida.

Denne mærkat sidder på apparatets øverste panel.

Tämä kyltti sijaitsee laitteen yläpinnalla.

Dette merket er plassert på oversiden av produktet.

CAUTION

The use of optical instruments with this product will increase eye hazard.

Use of controls or adjustments or performance of procedures other than those specified herein may result in hazardous radiation exposure.

VAROITUS!

LAITTEEN KÄYTTÄMINEN MUULLA KUIN TÄSSÄ KÄYTTÖOHJEESSA MAINITULLA TAVALLA SAATTAA ALTISTAA KÄYTTÄJÄN TURVALLISUUSLUOKAN 1 YLITTÄVÄLLE NÄKYMÄTTÖMÄLLE LASERSÄTEILYLLE.

VARNING

OM APPARATEN ANVÄNDS PÅ ANNAT SÄTT ÄN I DENNA BRUKSANVISNING SPECIFICERATS, KAN ANVÄNDAREN UTSÄTTAS FÖR OSYNLIG LASERSTRÅLNING, SOM ÖVERSKRIDER GRÄNSEN FÖR LASERKLASS 1.

For the customers in the U.S.A.

This equipment has been tested and found to comply with the limits for a Class A digital device, pursuant to Part 15 of the FCC Rules. These limits are designed to provide reasonable protection against harmful interference when the equipment is operated in a commercial environment. This equipment generates, uses, and can radiate radio frequency energy and, if not installed and used in accordance with the instruction manual, may cause harmful interference to radio communications. Operation of this equipment in a residential area is likely to cause harmful interference in which case the user will be required to correct the interference at his own expense.

You are cautioned that any changes or modifications not expressly approved in this manual could void your authority to operate this equipment.

All interface cables used to connect peripherals must be shielded in order to comply with the limits for a digital device pursuant to Subpart B of Part 15 of FCC Rules.

For the customers in the USA and Canada RECYCLING LITHIUM-ION BATTERIES

Lithium-Ion batteries are recyclable. You can help preserve our environment by returning your used rechargeable batteries to the collection and recycling location nearest you.



For more information regarding recycling of rechargeable batteries, call toll free 1-800-822-8837, or visit <http://www.rbrclion.org/>

Caution: Do not handle damaged or leaking lithium-ion batteries.

For the State of California, USA only

Perchlorate Material - special handling may apply, See www.dtsc.ca.gov/hazardouswaste/perchlorate
Perchlorate Material : Lithium battery contains perchlorate.

For the customers in Europe

This product with the CE marking complies with the EMC Directive issued by the Commission of the European Community.

Compliance with this directive implies conformity to the following European standards:

- EN55103-1: Electromagnetic Interference (Emission)
- EN55103-2: Electromagnetic Susceptibility (Immunity)

This product is intended for use in the following Electromagnetic Environment(s):

E1 (residential), E2 (commercial and light industrial), E3 (urban outdoors) and E4 (controlled EMC environment, ex. TV studio).

The manufacturer of this product is Sony Corporation, 1-7-1 Konan, Minato-ku, Tokyo, Japan.

The Authorized Representative for EMC and product safety is Sony Deutschland GmbH, Hedelfinger Strasse 61, 70327 Stuttgart, Germany. For any service or guarantee matters please refer to the addresses given in separate service or guarantee documents.

For the customers in Taiwan only



廢電池請回收

Table of Contents

| | |
|---|----------|
| Foreword | 7 |
| Before Use | 7 |
| Frame Frequency Indications for Interlaced Signals | 7 |

Chapter 1 Overview

| | |
|---|-----------|
| Product Configurations | 8 |
| Features | 9 |
| Camera Features | 9 |
| Features of the Optical Disc Drive (VDR) ... | 9 |
| Input/Output Features | 11 |
| Other Features | 11 |
| Location and Function of Parts | 12 |
| Front | 12 |
| Right Side | 14 |
| Status Display on the LCD Monitor | 16 |
| Left Side and Upper Section | 21 |
| Rear | 23 |
| VCL-719BXS Auto Focus Lens (Supplied with the PDW-F335K) | 25 |
| DXF-20W Viewfinder | 27 |
| Status Display on the Viewfinder Screen ... | 28 |

Chapter 2 Preparations

| | |
|--|-----------|
| Attaching and Replacing the Lithium Battery | 30 |
| Preparing a Power Supply | 31 |
| Using a Battery Pack | 31 |
| Using an AC Adaptor | 31 |
| Setting the Area of Use and the Frame Frequency | 32 |
| Using the Unit for the First Time | 32 |
| Setting the Frame Frequency | 32 |
| Setting the Date and Time of the Internal Clock | 34 |
| Preparing the Lens | 35 |
| Mounting the Lens | 35 |
| Adjusting the Flange Focal Length | 35 |
| Adjusting the Viewfinder | 37 |

| | |
|--|-----------|
| Detaching the Viewfinder | 37 |
| Adjusting the Viewfinder Position | 37 |
| Adjusting the Eyepiece Focus and the Screen (Brightness, Contrast, and Outline Emphasis) | 37 |
| Attaching a 5-inch Electronic Viewfinder . | 38 |
| Using the Shoulder Strap | 39 |
| Adjusting the Shoulder Pad Position | 39 |
| Mounting on a Tripod | 40 |
| Using a Video Light | 40 |
| Preparing the Audio Input System | 41 |
| Using the Supplied Microphone | 41 |
| Using an External Microphone | 41 |
| Attaching a UHF Synthesized Tuner | 42 |
| Connecting Line Input Audio Equipment.. | 44 |
| Connecting the Remote Control Unit | 44 |
| Connecting | 46 |
| Connecting an External Video Monitor | 46 |
| Using an i.LINK Connection | 46 |
| Connections for Using the PDZ-1 | 47 |

Chapter 3 Recording and Playback

| | |
|--|-----------|
| Handling Discs | 48 |
| Discs Used for Recording and Playback ... | 48 |
| Notes on Handling | 48 |
| Write-Protecting Discs | 48 |
| Loading and Unloading a Disc | 49 |
| Formatting a Disc | 49 |
| Handling of Discs When Recording Does Not End Normally (Salvage Function) ... | 50 |
| Basic Procedure for Shooting | 51 |
| Recording – Basic Operations | 53 |
| Selecting the Recording Format | 53 |
| Adjusting the Black Balance/White Balance | 54 |
| Setting the Electronic Shutter | 57 |
| Adjusting the Iris | 59 |
| Adjusting the Audio Level | 60 |
| Setting the Time Data | 61 |
| Setting for Special Shooting Cases | 64 |
| Deleting Clips | 64 |
| Recording Shot Marks | 65 |

| | |
|---|-----------|
| Setting the Thumbnail Image at Recording Time | 65 |
| Recording – Advanced Operations | 66 |
| Time-lapse Video Recording (Interval Rec Function) | 66 |
| Starting a Shoot with a Few Seconds of Pre-Stored Picture Data (Picture Cache Function) | 68 |
| Assigning User-Defined Clip Titles Automatically | 69 |
| Assigning User-Defined Clip and Clip List Names | 71 |
| Recording with the Clip Continuous Rec Function | 73 |
| Playback | 74 |
| Normal Playback | 74 |
| Checking the Last Two Seconds of the Recording (Recording Review) | 75 |
| Checking the Recording on a Color Video Monitor | 75 |
| Thumbnail Search | 76 |
| Searching Using Thumbnails | 76 |
| Switching the Information Displayed in the Thumbnail Screen | 77 |
| Changing the Thumbnail Image (Index Frame) of a Clip | 77 |
| Cuing Up a Frame by Searching for an Essence Mark | 78 |
| Searching Using the Chapter Function | 79 |
| Searching Using the Expand Function | 79 |
| Clip List Playback | 80 |
| Locking (Write-Protecting) Clips | 81 |
| Deleting Clips | 82 |

Chapter 4 Scene Selection

| | |
|--|-----------|
| Overview | 84 |
| Creating Clip Lists | 87 |
| Including Sub Clips in the Current Clip List | 87 |
| Adding Sub Clips Using the Expand Function | 89 |
| Adding Sub Clips Using the Chapter Function | 90 |
| Editing Clip Lists | 91 |

| | |
|--|-----------|
| Reordering Sub Clips | 91 |
| Adjusting Sub Clip In/Out Points (Trimming) | 91 |
| Deleting Sub Clips | 92 |
| Saving the Current Clip List to Disc | 92 |
| Setting the Start Timecode for the Current Clip List | 93 |
| Switching the Information Displayed on Thumbnails | 93 |
| Managing Clip Lists | 94 |
| Loading a Clip List from the Disc as the Current Clip List | 95 |
| Deleting a Clip List from the Disc | 95 |
| Sorting the List of Clip Lists | 95 |
| Using the PDZ-1 Proxy Browsing Software | 97 |

Chapter 5 Menu Displays and Detailed Settings

| | |
|--|------------|
| Menu Organization and Operation | 98 |
| TOP Menu | 106 |
| Menu List | 107 |
| Displaying Menus | 130 |
| Basic Menu Operations | 130 |
| Using the USER Menu (Example Menu Operation) | 131 |
| Editing the USER Menu | 132 |
| Resetting USER Menu Settings to the Standard Settings | 134 |
| Resetting USER Menu Settings to the Factory Default Settings | 135 |
| Setting the Status Display on the Viewfinder Screen and the LCD Monitor | 135 |
| Selecting the Display Items | 135 |
| Change Confirmation/Adjustment Progress Messages | 136 |
| Setting the Marker Display | 136 |
| Setting the Viewfinder Screen Display | 137 |
| Recording Shot Data Superimposed on the Color Bars | 137 |
| Setting the Shot ID | 138 |
| Showing the Status Display | 139 |

Adjustments and Settings from Menus 140

| | |
|---|-----|
| Setting Gain Values for the GAIN Switch Positions | 140 |
| Selecting the Output Signals..... | 140 |
| Setting the Color Temperature Manually . | 140 |
| Specifying an Offset for the Auto White Balance Setting..... | 141 |
| Setting the Amount of Compensation for Color Casts by ND Filters | 141 |
| Selecting Gamma Tables | 142 |
| Making Low-Noise mode Settings | 142 |
| Assigning Functions to ASSIGN Switches | 143 |
| Selecting the Lens File..... | 143 |
| Selecting the Aspect Ratio..... | 144 |
| About the CCD Scan Mode | 144 |

Chapter 6 Saving and Loading User Setting Data

| | |
|--|------------|
| Saving and Loading User Files | 146 |
| Handling the “Memory Stick” | 146 |
| Saving USER Menu Data (User File) to the “Memory Stick” | 147 |
| Loading Saved Data from a “Memory Stick” | 149 |
| Saving and Loading Scene Files | 150 |
| Saving a Scene File..... | 150 |
| Loading Scene Files..... | 152 |
| Resetting the Settings of the Camcorder to the Standard Settings..... | 153 |

Chapter 7 File Operation

| | |
|---|------------|
| Overview | 155 |
| Directory Structure | 155 |
| File Operation Restrictions | 156 |
| File Access Mode File Operations (for Windows)..... | 158 |
| Making FAM Connections | 158 |
| Operating on Files..... | 159 |
| Exiting File Operations..... | 159 |
| File Operations in File Access Mode (for Macintosh)..... | 160 |

| | |
|------------------------------|-----|
| Making FAM Connections | 160 |
| Operating on Files..... | 161 |
| Exiting File Operations..... | 161 |

Recording Continuous Timecode over FAM Connections..... 162

Appendix

| | |
|---|------------|
| Important Notes on Operation | 163 |
| Phenomena Specific to CCD Image Sensors | 164 |
| Condensation | 164 |
| Maintenance | 165 |
| Testing the Camcorder Before Shooting . | 165 |
| Maintenance..... | 167 |
| Note About the Battery Terminal | 167 |
| Operation Warnings | 168 |
| Troubleshooting | 172 |
| Using UMID Data | 174 |
| MPEG-4 License | 176 |
| MPEG-2 Video Patent Portfolio License | 176 |
| About i.LINK | 177 |
| About a “Memory Stick” | 178 |
| Specifications | 180 |
| Chart of Optional Components and Accessories | 184 |
| Glossary | 185 |
| Index | 188 |

Foreword

Before Use

After purchasing this unit, before operating, it is necessary to set the region of use and the frame frequency.
(Unless these settings are made, the unit will not operate.)

For details of these settings, see “Setting the Area of Use and the Frame Frequency” on page 32.

Frame Frequency Indications for Interlaced Signals

In the menus of this unit, the frame frequency of an interlaced signal is shown as “60I” or “50I”, with a capital letter, but in this manual these are shown as “60i” and “50i” with a lower-case letter.

For progressive signals, both menus and manual use a capital letter (e.g. “30P”, “25P”, “23.98P”).

Product Configurations

The PDW-F335 Professional Disc Camcorder series includes the models PDW-F335L and PDW-F335K, with different product configurations. The components and

accessories supplied of these models are as shown in the following figure.

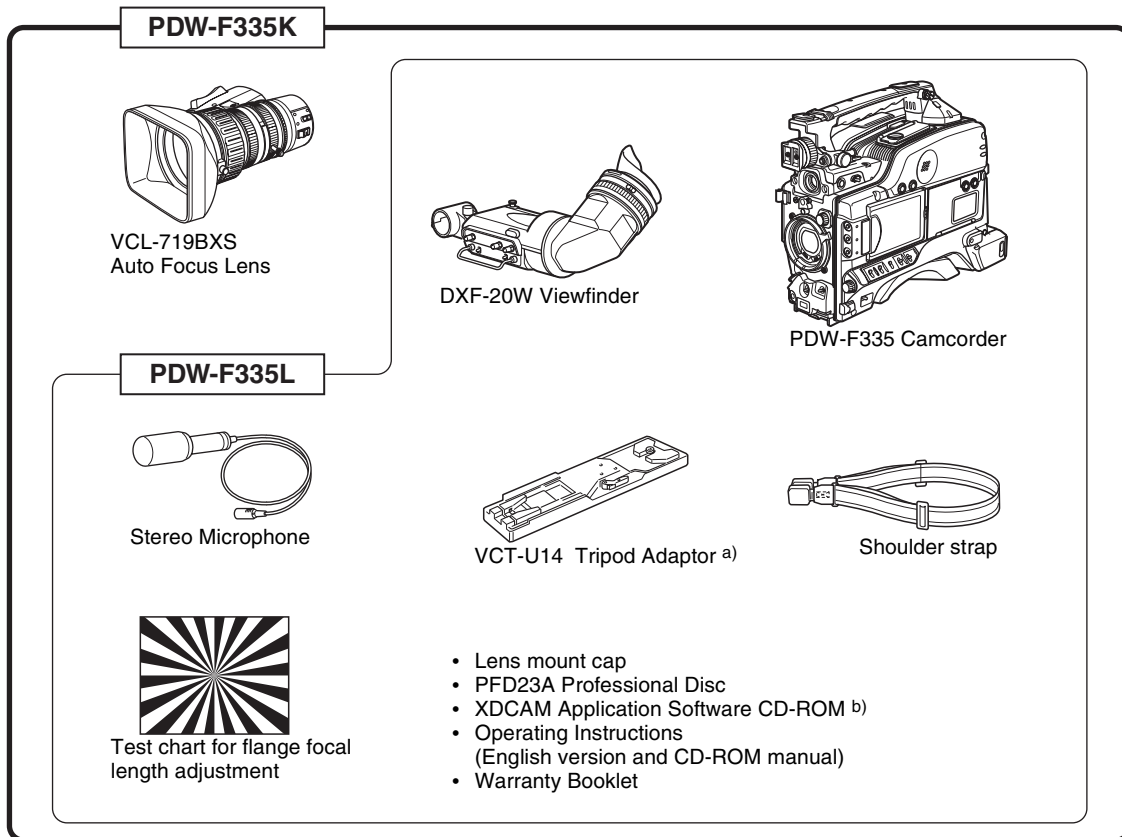

a) Use a tripod adaptor with a suffix of “-E” or later on the model name.

For more details, see “Mounting on a Tripod” (page 40).

b) The XDCAM Application Software CD-ROM contains the PDZ-1Proxy Browsing Software, PDZ-VX10 XDCAM Viewer, and PDZK-P1 XDCAM Transfer.

Features

The PDW-F335 is an XDCAM¹⁾ HD²⁾ camcorder integrating an HD video camera using three HD CCDs of the 1/2-inch type with a total effective pixel count of 1.56 million, and a Professional Disc¹⁾ drive.

This unit provides a range of useful shooting functions for video production, and allows shooting and recording in both progressive scan and interlace scan modes with an HD image having 1080 effective scan lines. Since it also supports SD³⁾ DVCAM recording, it can be used through a transition from SD to HD production.

The use of Professional Disc adds high reliability to recording and playback, and the unit also includes many playback and editing functions exploiting the possibilities of random access.

1) XDCAM and "Professional Disc" are trademarks of Sony Corporation.

2) HD: High Definition

3) SD: Standard Definition

Camera Features

1/2-inch HD CCD

The use of three interline transfer CCD with an effective pixel count of approximately 1.56 million (1440 × 1080) enables high sensitivity, high picture quality, and high fineness video shooting.

Camera signal processing for high quality video

A specially-developed ASIC (application specific integrated circuit) for signal processing provides the following functions.

- A 12-bit A/D converter ensures recording of pictures stable at high quality.
- Both progressive and interlace scan modes are supported.
- You can select from five HD shooting/recording modes: 23.98P¹⁾, 25P, 29.97P²⁾, 50i, and 59.94i³⁾, for ideal support of various applications including digital cinema production, program production, and event video production.
- For recording and playback in the DVCAM format (SD), the aspect ratio (16:9/4:3) and standard broadcasting system (NTSC/PAL) can be freely selected. Further, when NTSC is selected, video shot at 23.98P can also be subjected to 2-3 pulldown and recorded. (The recording format is then 59.94i.)

1) In this system, shown as 23.9P or 23.98P.

2) In this system, shown as 30P.

3) In this system, shown as 60I.

Shooting functions provide various effects

This unit is equipped with many of the functions provided in a film camera, allowing the operator creative control through a variety of techniques.

Slow shutter function

A maximum of 64 frames can be accumulated using the slow shutter function. In low light levels this allows clear and noiseless video to be shot, and provides a fantasy video effect with ghost images.

Time lapse function (interval recording)

Using this function slow-moving subjects can be shot with the movement compressed in time. This is convenient for many applications, such as monitoring plant growth, or the progress of a construction site.

Shooting functions to cope with different shooting conditions

- The ATW¹⁾ and auto iris functions allow shooting with automated adjustment of the white balance and intensity levels to cope with varying ambient lighting conditions.
- By switching among the four levels (including CLEAR) of neutral density (ND) filter, it is possible to compensate for lighting conditions, and control the depth of field.
- When shooting in daylight or other high color temperature illumination, pressing the 5600K button instantly switches the color temperature setting to 5600K²⁾.
- With the GAIN switch, you can adjust the gain of the video amplifier according to the lighting conditions when shooting. You can vary the setting in the GAIN switch positions (H/M/L) to any values in the range -3 dB to +48 dB.

1) Auto Tracing White balance

2) Only when the WHITE BAL switch is in the PRST position

Saving and recalling settings on a "Memory Stick"

Using a "Memory Stick"¹⁾ (supplied separately), you can save menu settings adjusted to particular shooting conditions, and then recall those settings as required.

1) "Memory Stick" is a trademark of Sony Corporation.

Features of the Optical Disc Drive (VDR)

Support for HD/SD recording and playback formats

For HD video recording format, MPEG-2 MP@HL compression is used, and the image quality (bit rate) and recording time¹⁾ can be selected according to the shooting

application. Recording in the DVCAM format is also supported. The audio is recorded as four channels or two channels ²⁾, uncompressed.

- 1) The recording mode can be selected from the three modes: HQ (High Quality), SP (Standard Play) and LP (Long Play).
- 2) DVCAM recording is available for four channels only.

Proxy AV data recording

Proxy AV data is low resolution data using MPEG-4 (video 1.5 Mbps, audio 64 kbps per channel). With this unit, when recording HD or SD high resolution data, low resolution Proxy AV data is automatically generated at the same time, and recorded.

Since Proxy AV data is compact, it can be transferred to a computer or network at high speed, enormously reducing the storage capacity required for recording. Exploiting this allows a laptop computer to be used for editing ¹⁾, allows content management on an inexpensive and compact server, and makes many other applications easy to implement.

- 1) Using the supplied PDZ-1 Proxy Browsing Software, a simple EDL (edit decision list) can be created.

Saving general-purpose files

The Professional Disc has an area of approximately 500 MB provided for storing general-purpose computer files.

Long recording times

When dual-layer Professional Discs are used, this unit can record about 190 minutes in SP mode and about 185 minutes in DVCAM mode.

Recording and playback in clip units

A clip is created each time recording is started and stopped.

- Recording always writes to an empty area of the disc. Therefore, even if playback is carried out between shooting sessions, there is no danger of the next shot inadvertently overwriting previous material. During playback, the next recorded can always be started immediately.
- Since unwanted clips can be deleted on this unit immediately after they are recorded, the disc capacity can be used effectively.

It is also possible to keep recording to the same clip even when recording stops and starts again. (In this manual, this feature is called the “Clip Continuous Rec” function.) The Clip Continuous Rec function can be turned on and off from the menu system.

For details, see “Recording with the Clip Continuous Rec Function” (page 73).

Convenient playback and search functions exploiting the disc characteristics

Thumbnail search

Pressing the THUMBNAIL button on this unit displays a representative image for each clip as a thumbnail on the LCD (liquid crystal display) monitor, in the viewfinder, and on the external video monitor.

Selecting a thumbnail with the cursor and pressing the PLAY/PAUSE button allows any clip to be checked easily.

Essence mark search

During or after movie recording, an essence mark can be recorded on any scene. A list of frames with an essence mark recorded can be displayed on the LCD monitor, in the viewfinder, and on the external video monitor. Essence marks can also be added after recording using the supplied PDZ-1 Proxy Browsing Software.

Expand function

The expand function allows you to divide a selected clip into 12 blocks, and to display thumbnails of the first frame in each block in the thumbnail list. You can also divide the segment between a selected essence mark and the next essence mark in the same way. The expansion can be repeated up to three times to display a total of 1728 thumbnails. This function allows you to quickly review the selected clip or segment and to search efficiently for a target scene.

Scene selection

You can select clips on the disc to create a clip list. The clips in this list can be played back in any order. A single disc can hold up to 99 clip lists.

Audio recording functions

Audio is recorded as uncompressed data with 16-bit quantization, and a sampling frequency of 48 kHz. Depending on shooting requirements and recording time, either two or four audio channels can be selected. (Only four channels for DVCAM recording.)

- The unit is equipped with a stereo front microphone.
- There are two AUDIO IN connectors (XLR, 3-pin) on the rear of the unit, which can be used for line and microphone input.
- The CA-WR855 Camera Adaptor (supplied separately) can be used to install the WRR-855 series slot-in type UHF synthesized tuner (supplied separately) without using any connecting cable.
- The audio signals to be recorded on the disc can be freely selected from the audio inputs to the stereo microphone, AUDIO IN connectors and the UHF synthesized tuner, and assigned to any desired audio channel.

Input/Output Features

Equipped with an i.LINK connector

The i.LINK connector on this unit supports the following two functions.

DV stream output (AV/C ¹ mode connection): A DV stream can be output from the i.LINK connector on this unit, and recorded on a DV recorder or nonlinear editor supporting DV. For recording and playback in MPEG HD format, a down-converted DV stream can be output.

File access from a computer (FAM ² connection): An FAM connection between this unit and a computer allows the video, audio, and metadata information on the disc to be read and written as files. (The data can be written and read as normal files on a computer.) With this function, a nonlinear editing device connected to this unit can be used for direct HD video editing or simple Proxy AV data editing, enabling a more efficient workflow.

1) Audio/Video Control

2) File Access Mode

Other signal input/output connectors

HD/SD analog component output connector

During HD video recording and playback, either an HD signal or down-converted SD signal can be output. (The output signal selection is carried out in a menu.)

Composite video output connector

50i/25P video is output as a PAL signal, 60i/30P video is output as an NTSC signal, and 23.98P video is output as an NTSC signal which has undergone 2-3 pulldown processing.

Timecode input/output connectors

The unit is provided with a single input/output connector (controlled by a switch).

GENLOCK connector

The SD or HD reference signal can be input to apply a genlock to the camera.

Video light connector

There is an interface connector for a maximum 50 W video light, and a control switch. Depending on the switch setting, the light can be turned on and off as recording starts and stops.

Remote control connector

Connect the RM-B150/B750 remote control unit (supplied separately) or other remote commander, to allow remote operation of the shooting functions of this unit.

Audio output connectors

The unit is provided with phono jacks, allowing stereo output.

Earphone jack (monaural/stereo)

Audio channels to be monitored can be selected with the MONITOR switch on the side of the unit. Switch between monaural and stereo using the menus.

Other Features

User-friendly interface functions

ASSIGN (assignable) switches

The unit is provided with four ASSIGN switches; two on the front and the others on the top of the grip. You can assign various functions to these switches. By assigning frequently used functions to the switches, you can call up the desired functions instantly, for example during shooting operations. The functions that can be assigned are as follows.

- Lens zoom control (telephoto/wide-angle)
- Easy focus function
- Turbo gain function

3.5-inch color LCD monitor

The LCD monitor on the side of the unit can be switched to show the following images and data.

- Status information, including audio level meters for four channels and timecode
- List of thumbnails of the video recorded on the Professional Disc
- A playback image of the video recorded on the Professional Disc
- The camera image

Notes

- The image in the LCD monitor has about 4% cropped from each of the four edges of the actually captured video image. For accurate framing, always use the viewfinder.
- When the area of use is set to "PAL AREA" (frame frequency 50i or 25P), the image in the LCD monitor may be reduced in quality, with jaggies on diagonal lines, but this is not a malfunction.

Location and Function of Parts

Front

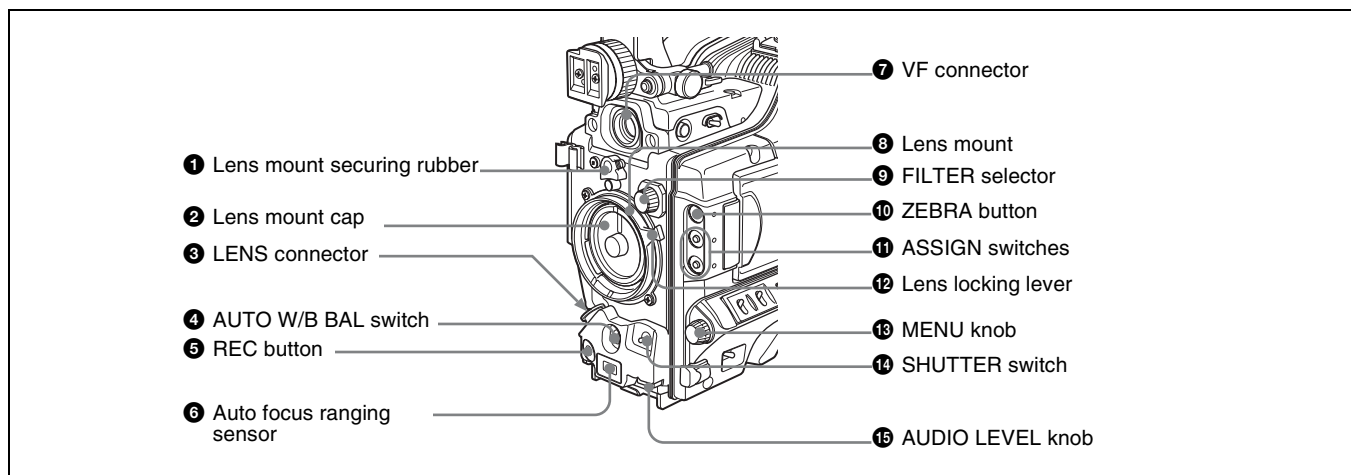

1 Lens mount securing rubber

After locking the lens in position using the lens locking lever, fit this rubber over the lower of the two projections. This fixes the lens mount, preventing it from coming loose.

2 Lens mount cap

Remove by pushing up the lens locking lever (*see page 13*). When no lens is mounted, keep this cap fitted for protection from dust.

3 LENS connector (12-pin)

Connect a lens cable if you are using a 2/3-inch lens or a cable-type 1/2-inch lens. This connector is not used for a 1/2-inch lens which is connected by a hot shoe inside the lens mount.

Consult your Sony dealer when you are using a lens other than VCL-719BXS (supplied with the PDW-F335K).

Note

When mounting or removing the lens on this unit, power off this unit first.

4 AUTO W/B BAL (automatic white/black balance adjustment) switch

Activates the automatic white/black balance adjustment functions.

WHT: Adjusts the white balance automatically. If the WHITE BAL switch (*see page 15*) is set to A or B, the white balance setting is stored in the corresponding memory. If the WHITE BAL switch is set to PRST, the automatic white balance adjustment function does not operate.

BLK: Adjusts the black set and black balance automatically.

5 REC (recording start) button

Press to start recording. Press it again to stop recording. The effect is the same as that of the REC button on the supplied lens. When the REC SWITCH function is assigned to an ASSIGN switch on the ASSIGNABLE page of the OPERATION menu, you can use the switch as the REC button.

6 Auto focus ranging sensor

When an VCL-719BXS (supplied with the PDW-F335K) auto focus lens is mounted, this measures the distance to the subject, and automatically focuses the lens.

This sensor is provided as an auxiliary function for improving the automatic focusing speed. Even if this sensor is blocked, the focusing precision will not be affected.

7 VF (viewfinder) connector (20-pin)

Connect the supplied viewfinder.

8 Lens mount (special bayonet mount)

Attach the lens.

9 FILTER selector

Selects from the four neutral density (ND) filters built into this unit.

| Position number | ND filter |
|-----------------|--|
| 1 | CLEAR |
| 2 | 1/4 ND (attenuates light to approximately 1/4) |
| 3 | 1/16 ND (attenuates light to approximately 1/16) |
| 4 | 1/64 ND (attenuates light to approximately 1/64) |

Normally set this to 1 (CLEAR).

For shooting with the lens iris wide open for reduced depth of field, or when the subject is too brightly lit and the auto iris function does not operate correctly, select an appropriate position.

When this selector is used with the menu item for filter selection display set to ON (*see page 136*), the new setting appears on the viewfinder screen for about 3 seconds. You can change a MAINTENANCE menu setting so that different white balance settings can be stored for different FILTER selector positions. This allows you to automatically obtain optimum white balance for the current shooting conditions in linkage with the filter selection.

For details, see “To adjust the white balance” (page 55).

10 ZEBRA button

Press to display a zebra pattern (diagonal stripes) in the viewfinder screen.

The zebra pattern is factory set to indicate picture areas where the video level is approximately 70%. However, on the VF SETTING page of the OPERATION menu, you can change the setting so that areas where the video level is 100% and above are also indicated at the same time. In addition, you can also change the video level for displaying the zebra pattern in the range from 30% to 107%.

For details, see “Setting the Viewfinder Screen Display” on page 137.

11 ASSIGN switches

You can assign the desired functions to each of the EZ MODE 1 and ASSIGN 2 switches on the ASSIGNABLE page of the OPERATION menu.

The following functions are factory preset to the switches.

| Switch | Function |
|----------------------|--|
| ASSIGN 1/ EZ MODE | EZ MODE (EZ mode ON/OFF) |
| ASSIGN 2 | No assignment (equivalent to an OFF selection in the function assignment menu) |

For details, see “Assigning Functions to ASSIGN Switches” on page 143.

12 Lens locking lever

After inserting the lens in the lens mount, rotate the lens mount ring with this lever to lock the lens in position.

After locking the lens, be sure to use the lens mount securing rubber to prevent the lens from becoming detached.

13 MENU knob

Changes the page selection or a setting within the menu.

For details about how to use the MENU knob, see “Basic Menu Operations” on page 130.

14 SHUTTER switch

Set to ON to use the electronic shutter. Flick to SEL to switch the shutter speed or shutter mode setting within the range previously set with the menu. When this switch is operated, the new setting appears on the setting change/adjustment progress message display area for about 3 seconds.

For details about the shutter speed and shutter mode settings, see “Setting the Electronic Shutter” on page 57.

15 AUDIO LEVEL knob

Adjusts the input level of audio channels 1 and 2.

You can disable this knob by setting the AUDIO CH1 LEVEL and AUDIO CH2 LEVEL items on the AUDIO-1 page of the MAINTENANCE menu. (The knob is factory preset so that it is enabled.)

Right Side

Near the front

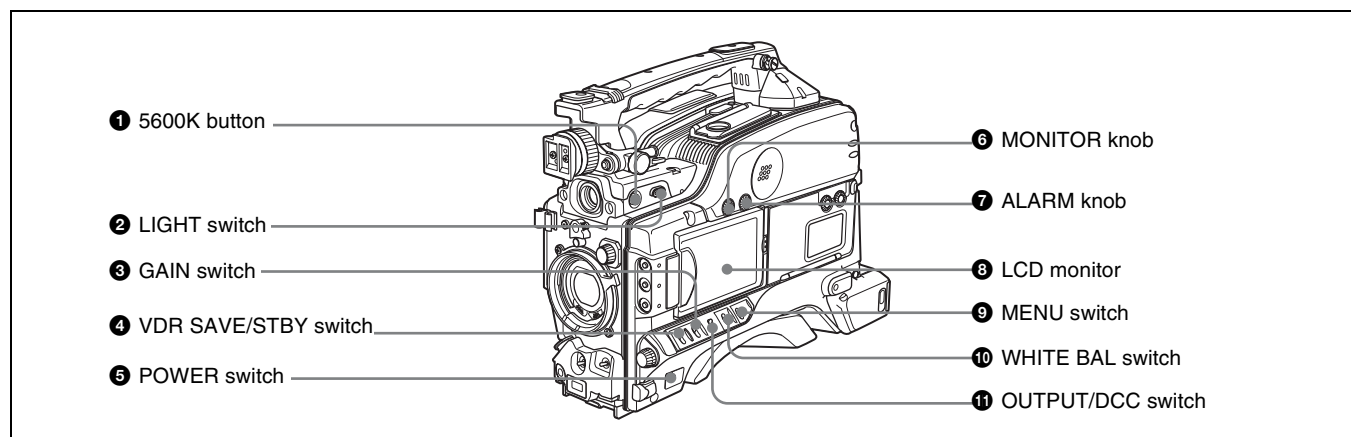

1 5600K button

Press to light the button and switch the standard color temperature for shooting to 5600K. Use this button for outdoor shooting in daytime or shooting under lighting with higher temperature. This button is effective only when the WHITE BAL switch is set to PRST.

2 LIGHT switch

Determines how a video light connected to the LIGHT connector (*see page 22*) is turned on and off.

AUTO: When the POWER switch of the video light is in the on position, the video light is turned on automatically while the camcorder is recording.

MAN: You can turn the video light on or off manually, using its own switch.

Notes

- When this switch is set to AUTO, at the beginning of the recording, the picture is recorded even though the lighting may fluctuate until the video light comes on. If the beginning of the recording is important, you should set this switch to MAN. However, when using the interval recording mode, the video light is automatically turned on immediately before recording starts.
- To ensure proper operation of the video light, Sony recommends the use of the BP-GL95 Battery Pack with the camcorder.

3 GAIN switch

Switches the gain of the video amplifier to match the lighting conditions during shooting. The gains corresponding to the L, M, and H settings can be selected in the menu. (The factory settings are L = 0 dB, M = 9 dB, and H = 18 dB.)

When this switch is adjusted, the new setting appears on the setting change/adjustment progress message display area of the viewfinder screen for about 3 seconds.

For details, see “Setting Gain Values for the GAIN Switch Positions” on page 140.

4 VDR SAVE/STBY (VDR save/standby) switch

Switches the status of the power supply to the VDR while recording is paused (REC PAUSE).

SAVE: At the start of recording, an internal operating sound may be recorded. There is a small delay from pressing the REC button until recording starts, since the power consumption is less than in the standby state.

STBY: When the REC button is pressed, recording starts immediately.

Notes

- Even if the switch is on the SAVE side, the unit exits SAVE (power saving) mode and enters STBY (standby) mode whenever you exit REC PAUSE mode by carrying out playback to check the recorded video or by displaying the thumbnail screen (*page 76*). To put the unit into SAVE mode again, put the unit into REC PAUSE mode again after recording, or power the unit off and on again.
- An internal operating sound may be recorded at the start of recording when the VDR SAVE/STBY switch is set to SAVE.

5 POWER switch

Turns the main power supply on and off.

6 MONITOR (monitor volume adjustment) knob

Controls the volume of the sound other than the warning tone that is output via the built-in speaker or optional earphones. When the knob is turned to the minimum setting, no sound can be heard.

7 ALARM (alarm tone volume adjustment) knob
 Controls the volume of the warning tone that is output via the built-in speaker or optional earphones. When the knob is turned to the minimum position, no sound can be heard.



8 LCD monitor
 Displays camera video, VDR-related warnings, remaining battery capacity, remaining disc space, audio levels, time data, and so on.

For details, see “Status Display on the LCD Monitor” on page 16.

9 MENU switch
 When flicking toward ON, the menu is displayed. When flicking toward STATUS, the status of the camcorder (of current settings) is displayed.

For details, see “Displaying Menus” on page 130.

10 WHITE BAL (white balance memory) switch
 Controls adjustment of the white balance.

PRST: Adjusts the color temperature to the preset value (the factory default setting: 3200K). Use this setting when you have no time to adjust the white balance.
A or B: Recall the white balance adjustment settings already stored in A or B.
 Press the AUTO W/B BAL switch (see page 12) on the WHT side, to automatically adjust the white balance, and save the adjustment settings in memory A or memory B. The 5600K button does not function. You can use the AUTO W/B BAL switch even when ATW ¹⁾ is in use.
B (ATW): When this switch is set to B and WHITE SWITCH is set to ATW on the WHITE SETTING page of the MAINTENANCE menu, ATW

is activated. When this switch is adjusted, the new setting appears on the setting change/adjustment progress message display area of the viewfinder screen for about 3 seconds. You can assign the ATW function to an ASSIGN switch on the ASSIGNABLE page of the OPERATION menu.

For details about how to assign the function to an ASSIGN switch, see “Assigning Functions to ASSIGN Switches” on page 143.

1) **ATW (Auto Tracing White Balance):** The white balance of the picture being shot is adjusted automatically for varying lighting conditions.

11 OUTPUT/DCC (output signal/dynamic contrast control) switch

Switches the video signal, which is output to the video disc drive (referred to as “VDR”), viewfinder, and video monitor from the camera section, between the following two.

BARS: Outputs the color bar signal.
CAM: Outputs the video signal from the camera. When this is selected, you can switch DCC ¹⁾ on and off.

1) **DCC (Dynamic Contrast Control):** Against a very bright background with the iris opening adjusted to the subject, objects in the background will be lost in the glare. The DCC function will suppress the high intensity and restore much of the lost detail and is particularly effective in the following cases.

- Shooting people in the shade on a sunny day
- Shooting a subject indoors, against a background through a window
- Any high contrast scene

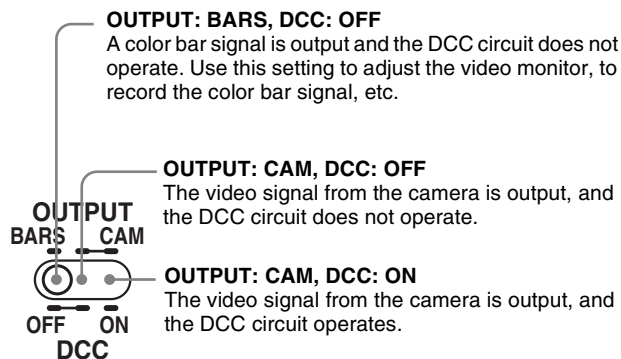

LCD monitor operating buttons

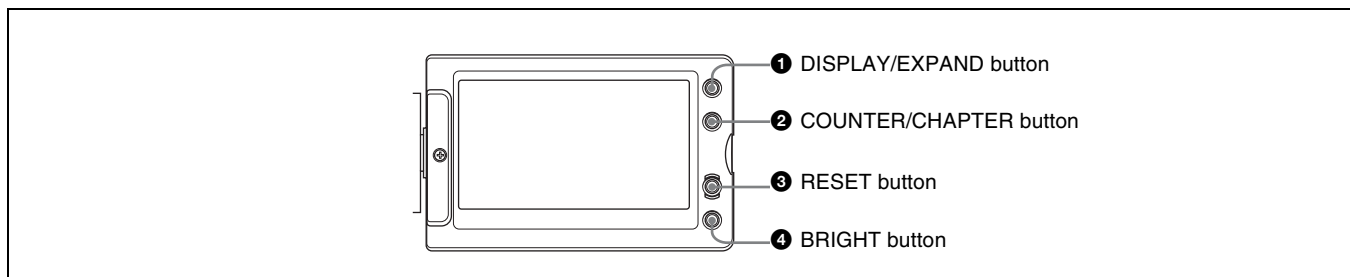

1 DISPLAY/EXPAND button
 Each time pressing this button, the display in the LCD monitor changes as follows.

| Display indication | Meaning |
|--|--|
| Video with superimposed information | When the MENU switch is flicked toward STATUS, the principal settings of this unit appear as on the viewfinder screen. |
| Video without superimposed information | The video only appears. |
| Status display | Counter indications, warnings, audio levels, and similar information appears. No video image appears. |

If you press this button when the thumbnail screen is displayed, the duration of the selected clip is divided into 12, and the first frame of each of the divisions is shown in a further thumbnail display (expand function). Each time you press the button, the division is repeated (to a maximum of three times, with 1728 divisions). Hold down the SHIFT button and press this button to step back through the division process.

For details of the expand function, see page 79.

2 COUNTER/CHAPTER (counter display toggle/ chapter) button

Each time this button is pressed, the counter display section changes as follows. This setting is activated only when the LCD monitor display is set to STATUS with the DISPLAY/EXPAND button.

COUNTER: Displays the elapsed recording/playback time.

TC: Displays timecode.

U-BIT: Displays user bits data.

If you press this button when the thumbnail screen is displayed, those frames on which essence marks are recorded appear in a list (chapter function). Press the button once more to return to the normal thumbnail display.

By displaying thumbnails with essence marks attached in place of index frames, you can check the contents of clips more easily and more quickly. This is also useful for cueing up long clips.

For details of the chapter function, see page 79.

3 RESET button

Resets the display of the time data when the LCD monitor display is set to STATUS or CHAR with the DISPLAY/EXPAND button. According to the settings of the PRESET/REGEN/CLOCK switch (see page 21) and the F-RUN/SET/R-RUN switch (see page 21), this button resets the display as follows.

| Settings of buttons and switches | To reset |
|------------------------------------|-----------------------|
| COUNTER/CHAPTER button: COUNTER | Counter to 0:00:00:00 |

| Settings of buttons and switches | To reset |
|--|--|
| COUNTER/CHAPTER button: TC PRESET/REGEN/CLOCK switch: PRESET F-RUN/SET/R-RUN switch: SET | Timecode to 00:00:00:00 |
| COUNTER/CHAPTER button: U-BIT PRESET/REGEN/CLOCK switch: PRESET F-RUN/SET/R-RUN switch: SET | User bits data ^{a)} to 00 00 00 00 ^{b)} |

a) Of the timecode bits for every frame recorded on the disc, those bits which can be used to record useful information for the user such as scene number, shooting place, etc.

b) Can only be reset when the display is set to STATUS. When it is set to CHAR, resetting is not possible.

For details, see "Setting the Time Data" on page 61.

If you press this button when thumbnails of frames with essence marks are displayed using the COUNTER/CHAPTER button, or when thumbnails of clip divisions are displayed using the DISPLAY/EXPAND button, then the display returns to the normal thumbnail display.

4 BRIGHT (brightness) button

Sets the backlight brightness. Each time you press this button, the backlight brightness cycles through the following four levels:

H: Select this to view the LCD monitor in outdoor daylight.

M: Brightness level between H and L.

L: Select this to view the LCD monitor indoors or outside at night.

OFF: Turn the backlight off (you can view video under normal lighting). Select this in outdoor daylight when the LCD monitor screen is subjected to direct sunlight.

Status Display on the LCD Monitor

The following display appears when the LCD monitor display is set to STATUS with the DISPLAY/EXPAND button.

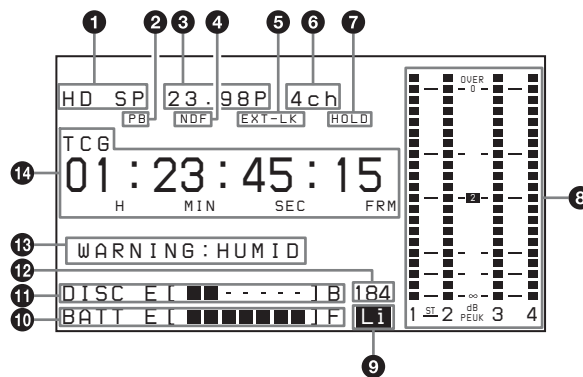

1 Video format

Indicates the format of video being currently played back or recorded.

HD HQ: HQ (high quality) mode in the MPEG HD video format

HD SP: SP (standard play) mode in the MPEG HD video format

HD LP: LP (long play) mode in the MPEG HD video format

DVCAM: DVCAM format

2 Playback indicator

Appears during playback.

3 Camera scan mode indicator

Indicates the camera scan mode of video being currently played back or recorded.

• If NTSC AREA is selected 1)

60I: 59.94 fields per second, interlace scan mode

30P: 29.97 frames per second, progressive scan mode

23.98P: 23.98 frames per second, progressive scan mode (converted to 60i at 2-3 pulldown)

• If PAL AREA is selected 1)

50I: 50 fields per second, interlace scan mode

25P: 25 frames per second, progressive scan mode

1) Selected by COUNTRY setting on the FORMAT page of the OPERATION menu (see page 108).

Note

There may be no indication displayed when this unit cannot identify the camera scan mode, for example, when playing back a disc recorded with other equipment.

4 Non-drop-frame mode indicator

Appears when non-drop-frame timecode is selected.

5 External synchronization indicator

Appears when the internal timecode generator is locked to an external signal input to the TC (timecode) connector (IN/OUT selector switch: IN).

6 Audio channel display

Shows the audio channel mode during recording or playback.

2ch: two-channel mode (only when the MPEG HD format is selected)

4ch: four-channel mode

7 Hold indicator

Appears when the internal timecode generator is stopped.

8 Audio level indicators

Indicates the audio recording or playback levels of channels 1 to 4.

9 Lithium battery low voltage warning

Appears when the voltage of the internal lithium backup battery (CR2032) is low. If this indication appears, replace the lithium battery immediately (see page 31).

10 Remaining battery capacity indicator

| Indication | Battery voltage | |
|-------------------------|-------------------|-----------------|
| | BP-L90A/L60S/L80S | Other batteries |
| BATT E [██████████] F | 15.5 V or more | 17.0 V or more |
| BATT E [██████████] F | 15.1 to 15.5 V | 16.0 to 17.0 V |
| BATT E [██████████] F | 14.6 to 15.1 V | 15.0 to 16.0 V |
| BATT E [██████████] F | 13.8 to 14.6 V | 14.0 to 15.0 V |
| BATT E [██████████] F | 12.9 to 13.8 V | 13.0 to 14.0 V |
| BATT E [██████████] F | 12.0 to 12.9 V | 12.0 to 13.0 V |
| BATT E [██████████] F | 10.8 to 12.0 V | 11.0 to 12.0 V |
| BATT E [██████████] F | 10.8 V or less | 11.0 V or less |

| Indication | Battery voltage |
|-------------------------|---|
| | BP-GL95/GL65/L75/M100, Anton Bauer Battery System |
| BATT E [██████████] F | 80 to 100% |
| BATT E [██████████] | 70% |
| BATT E [██████████] | 60% |
| BATT E [██████████] | 50% |
| BATT E [██████████] | 40% |
| BATT E [██████████] | 30% |
| BATT E [██████████] | 20% |
| BATT E [██████████] | 10% |
| BATT E [██████████] | 0% |

11 Remaining disc capacity indicator

| Indication | Remaining recording time |
|------------------------------------|--------------------------|
| DISC E [██████████] B | More than 30 minutes |
| DISC E [██████████] B | 25 to 30 minutes |
| DISC E [██████████] B | 20 to 25 minutes |
| DISC E [██████████] B | 15 to 20 minutes |
| DISC E [██████████] B | 10 to 15 minutes |
| DISC E [██████████] B | 5 to 10 minutes |
| DISC E [██████████] B | 2 to 5 minutes |
| DISC E [██████████] B (flashing) | 0 to 2 minutes |
| DISC E [██████████] B (flashing) | 0 minutes |

12 Remaining clips display

Displays the remaining number of clips that can be recorded. The display flashes once per second when the number of remaining clips is less than 10. It flashes 4 times per second when the number of remaining clips is 0.

13 Warning indicator area

Displays warnings when trouble with recording or moisture condensation occurs.

For details, see “Operation Warnings” on page 168.

14 Time counter display

Each press of the COUNTER/CHAPTER button cycles through displays of timecode, user bits, and counter information. You can display the date or time using the four-way arrow key on the side control panel.

TCG: Value of timecode generator

TCR: Value of timecode reader

UBG: Value of user bits generator

UBR: Value of user bits reader

CNT: Counter information

CLK: Time by the internal clock

TCG and UBG can be displayed when the disc is stopped and during recording, and TCR and UBR are displayed during playback.

CLK appears when the COUNTER/CHAPTER button has been pressed to display TC, and the PRESET/REGEN/CLOCK switch is set to CLOCK.

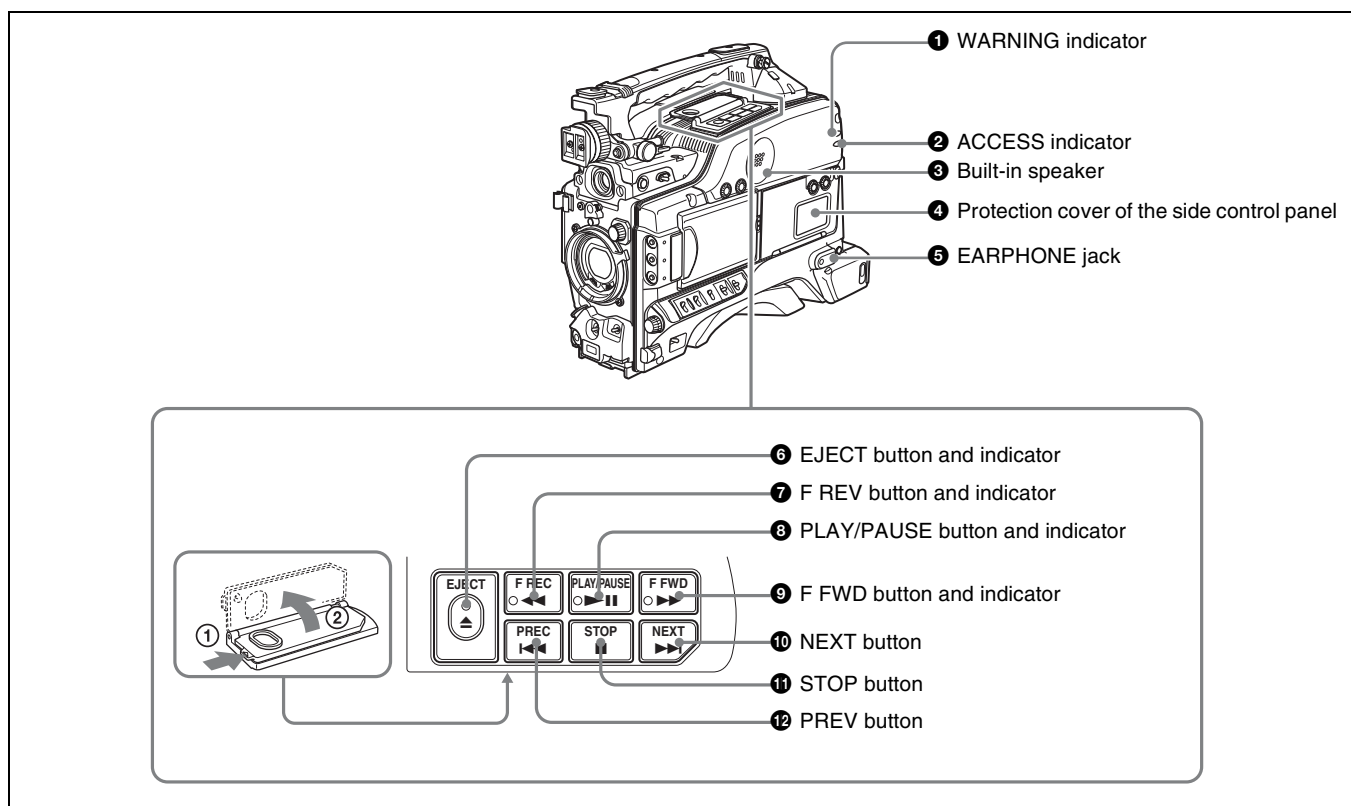
Near the rear**1 WARNING indicator**

Lights up or flashes when an abnormality occurs in the VDR section.

For details about the meaning of the states of the WARNING indicator, see “Operation Warnings” on page 168.

2 ACCESS indicator

This lights when data is written to or read from the disc.

3 Built-in speaker

The speaker can be used to monitor E-E ¹⁾ sound during recording, and playback sound during playback. The speaker also sounds alarms to reinforce visual warnings.

If you connect earphones to the EARPHONE jack, the speaker output is suppressed automatically.

1) **E-E:** Abbreviation of “Electric-to-Electric”. In E-E mode, video and audio signals input to the camcorder are output after passing through internal electric circuits only. This can be used to check input signals.

For details about alarms, see “Operation Warnings” on page 168.

4 Protection cover of the side control panel

Open to access the side control panel (see page 19).

5 EARPHONE jack

By plugging earphones, you can monitor the E-E sound during recording and playback sound during playback. When an alarm is indicated, you can hear the alarm sound

through the earphones. Plugging earphones into the jack automatically cuts off the sound from the built-in speaker. You can select monaural or stereo on the AUDIO-2 page of the MAINTENANCE menu.

6 EJECT button and indicator

Press this button to insert a disc or eject the disc. The indicator flashes while the disc is being ejected.

7 F REV (fast reverse) button and indicator

This plays back at high speed in the reverse direction. The indicator lights during high-speed playback in the reverse direction.

8 PLAY/PAUSE button and indicator

Press this button to view play back video images using the viewfinder screen or a color video monitor. The indicator lights during playback.

Press this button again during playback to pause, outputting a still image. At this time the indicator flashes. This unit is equipped with a color search function at approximately four times normal playback speed, for easy checking of recorded material. To use the color search function at approximately four times normal playback speed, press the F REV button or F FWD button during playback.

At this time the PLAY indicator and F REV or F FWD indicator light.

9 F FWD (fast forward) button and indicator

This plays back at high speed in the forward direction. The indicator lights during high-speed playback in the forward direction.

10 NEXT button

When FIND MODE on the ESSENCE MARK page of the MAINTENANCE menu is set to R.ST: This jumps to the next REC START essence mark.

When FIND MODE on the ESSENCE MARK page of the MAINTENANCE menu is set to CLIP: This jumps to the first frame of the next clip.

During the jump, the F FWD indicator flashes. If you press this together with the F FWD button, the jump is to the last frame of the last recorded clip on the disc.

For details, see "Recording Shot Marks" (page 65).

11 STOP button

Press this to stop disc playback.

12 PREV (previous) button

When FIND MODE on the ESSENCE MARK page of the MAINTENANCE menu is set to R.ST: This jumps to the previous REC START essence mark.

When FIND MODE on the ESSENCE MARK page of the MAINTENANCE menu is set to CLIP: This jumps to the first frame of the current clip, or jumps to the first frame of the previous clip when the PREV button is pressed at the first frame of the current clip.

During the jump, the F REV indicator flashes. If you press this together with the F REV button, the jump is to the start of the first recorded clip on the disc.

For details, see "Recording Shot Marks" (page 65).

Side control panel (inside the protection cover)

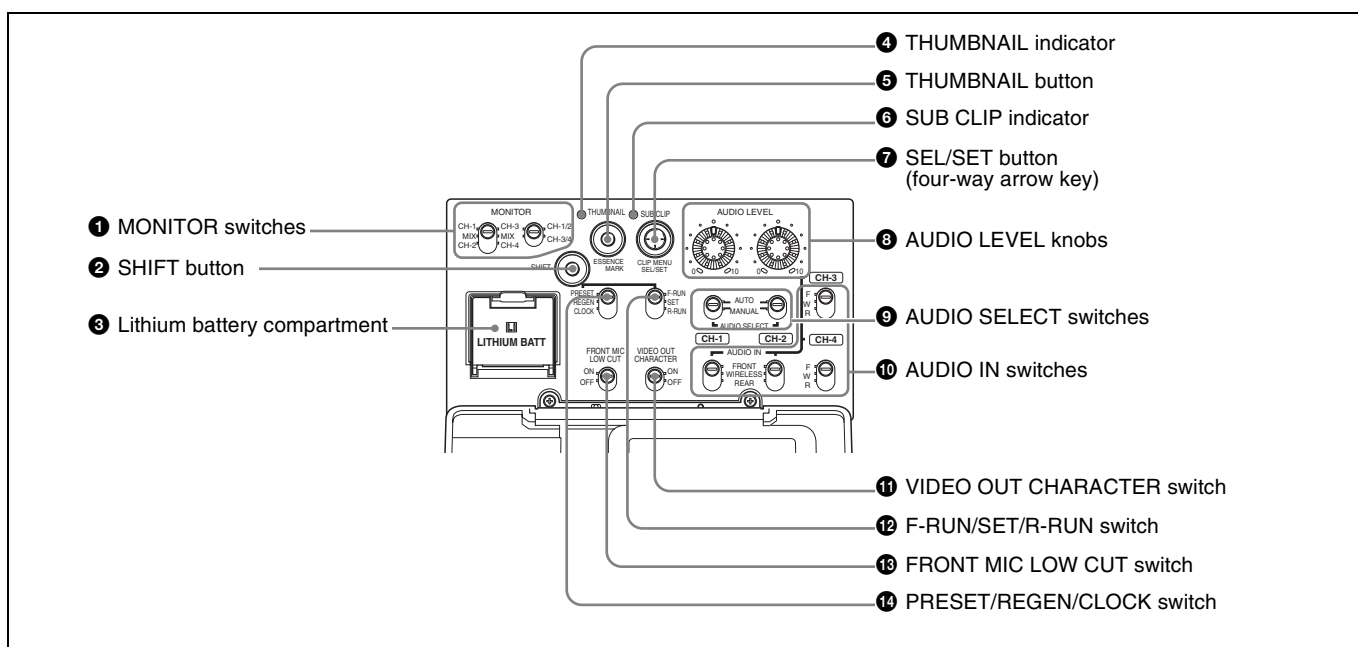

1 MONITOR (audio monitor selection) switches

By means of combinations of the two switches, you can select audio that you want to hear through the built-in speaker or optional earphones.

| Position of left-side switch | Position of right-side switch | Audio output |
|------------------------------|-------------------------------|---|
| CH-1/CH-3 | CH-1/2 | Channel 1 audio |
| MIX | | Channels 1 and 2 mixed audio (stereo) ^{a)} |
| CH-2/CH-4 | | Channel 2 audio |
| CH-1/CH-3 | CH-3/4 | Channel 3 audio |
| MIX | | Channels 3 and 4 mixed audio (stereo) ^{a)} |
| CH-2/CH-4 | | Channel 4 audio |

a) By connecting stereo headphones to the EARPHONE connector you can hear the audio in stereo. (On the AUDIO-2 page of the MAINTENANCE menu, HEADPHONE OUT must be set to "STEREO".)

2 SHIFT button

Use this in combination with other buttons.

3 Lithium battery compartment

Attach the supplied CR2032 lithium battery.

Details on how to attach the lithium battery, see "Attaching and Replacing the Lithium Battery" on page 30.

4 THUMBNAIL indicator

This lights when thumbnails are displayed.

5 THUMBNAIL button

Press this button to carry out a thumbnail search or create a clip list.

When pressed, the whole-screen display changes to a thumbnail display. Press once more to return to the whole-screen display.

For a thumbnail search using essence marks, hold down the SHIFT button and press this button.

6 SUB CLIP indicator

This lights when using a clip list for playback.

7 SEL/SET (select/set) button (four-way arrow key)

Sets the timecode and user bits. Push the button towards left or right so that the digit you want to change flashes. Pushing the button upward increases the value of the flashing digit, and pushing it downward decreases the value.

Hold down the SHIFT button and press upward (in the direction of the "SUB CLIP" legend) to display the clip lists (when no clip list is loaded into the current clip list). When a clip list is loaded, that clip list can be played back. Hold down the SHIFT button and press upward once more

to exit the display of the clip lists or to exit the clip list playback state.

Hold down the SHIFT button and press downward (in the direction of the "CLIP MENU" legend) to display the CLIP menu. Hold down the SHIFT button and press downward once more to exit the CLIP menu.

When thumbnails (index frames of clips) are displayed on the LCD monitor, you can use this button to select a thumbnail. Push the button in four directions to move the cursor up, down, left and right. After selecting the desired thumbnail with the cursor, press the button centrally to confirm.

This button is used for scene selection and other operations.

For details of clip list playback operations, see page 80.

For details of the CLIP menu, see "Managing Clip Lists" (page 94).

For details of scene selection, see page 84.

8 AUDIO LEVEL (CH-1/CH-2) (audio channel 1/2 recording level) knobs

Adjusts the audio levels to be recorded on channels 1 and 2 when the AUDIO SELECT (CH-1/CH-2) switches are set to MANUAL.

9 AUDIO SELECT (CH-1/CH-2) (audio channel 1/2 adjustment method selection) switches

Select the audio level adjustment method for each of audio channels 1 and 2.

AUTO: Automatic adjustment

MANUAL: Manual adjustment

10 AUDIO IN (CH-1/CH-2/CH-3/CH-4) (audio channel 1/2/3/4 input selection) switches**AUDIO IN CH-1/CH-2 switches**

Select the audio input signals to be recorded on audio channels 1 and 2.

FRONT: Input signals from the microphone connected to the MIC IN connector

WIRELESS: Audio input signals from the CA-WR855 Camera Adaptor (supplied separately) if a WRR-855 series UHF synthesized tuner (supplied separately) is installed using the CA-WR855

REAR: Audio input signals from an audio device connected to the AUDIO IN CH-1/CH-2 connectors

AUDIO IN CH-3/CH-4 switches

Select the audio input signals to be recorded on audio channels 3 and 4.

F (FRONT): Input signals from a microphone connected to the MIC IN connector

W (WIRELESS): Audio input signals from the CA-WR855 camera adaptor (supplied separately) if a

WRR-855 series UHF synthesized tuner (supplied separately) is installed using the CA-WR855

R (REAR): Audio input signals from an audio device connected to the AUDIO IN CH-1/CH-2 connectors (The signal input to the AUDIO IN CH-1 connector is recorded on channel 3, and the signal input to the AUDIO IN CH-2 connector on channel 4.)

Note

For audio channels 3 and 4, level adjustment can only be performed in AUTO (automatic) mode. The audio level of these channels cannot be adjusted in MANUAL (manual) mode.

11 VIDEO OUT (video output) CHARACTER switch
Selects whether or not (ON/OFF) to superimpose text information on the VIDEO OUT connector output.

12 F-RUN/SET/R-RUN (free run/set/recording run) switch

Selects the operating mode of the internal timecode generator. The operating mode is set as explained below, depending on the position of the switch.

F-RUN: Timecode keeps advancing, regardless of the operating state of the VDR. Use this setting when

synchronizing the timecode with an external timecode.

SET: Sets the timecode or user bits.

R-RUN: Timecode advances only during recording. Use this setting to have a consecutive timecode on the disc.

For details, see “To set the timecode” on page 61 and “To set the user bits” on page 62.

13 FRONT MIC LOW CUT switch

Set to ON to insert a high-pass filter in the microphone circuit, reducing wind noise. Normally leave the switch in the OFF position.

14 PRESET/REGEN (regeneration)/CLOCK switch
Selects whether to set a new timecode or to utilize the existing timecode.

PRESET: Records a new timecode.

REGEN: Records timecode continuous with the existing timecode recorded on the disc. Regardless of the setting of the F-RUN/SET/R-RUN switch, the camcorder operates in R-RUN mode.

CLOCK: Records timecode synchronized to the internal clock. Regardless of the setting of the F-RUN/SET/R-RUN switch, the camcorder operates in F-RUN mode.

Left Side and Upper Section

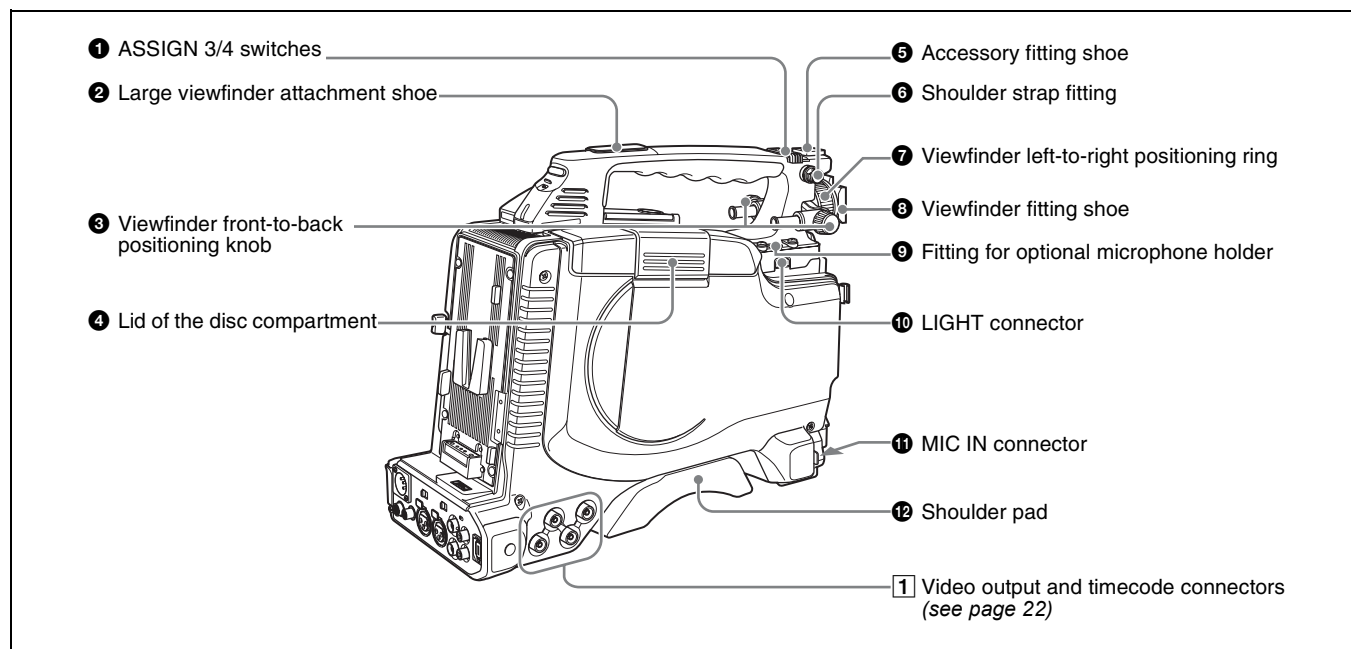

1 ASSIGN 3/4 switches

You can assign the desired functions to these switches on the ASSIGNABLE page of the OPERATION menu.

For details, see “Assigning Functions to ASSIGN Switches” on page 143.

2 Large viewfinder attachment shoe

Use this to mount an optional 5-inch electronic viewfinder (see page 38).

3 Viewfinder front-to-back positioning knob

Loosen this knob to adjust the front-to-back position of the viewfinder (see page 37).

4 Lid of the disc compartment

This opens when the EJECT button on the top panel is pressed. Press the side of the lid to close.

5 Accessory fitting shoe

Attach an optional accessory such as a video light (see page 40).

6 Shoulder strap fitting

Attach the supplied shoulder strap (see page 39).

7 Viewfinder left-to-right positioning ring

Loosen this ring to adjust the left-to-right position of the viewfinder (see page 37).

8 Viewfinder fitting shoe

Attach the supplied viewfinder.

9 Fitting for optional microphone holder

Fit an optional CAC-12 Microphone Holder (see page 41).

10 LIGHT (video light) connector (2-pin, female)

A video light with a maximum power consumption of 50 W, such as the Anton Bauer Ultralight 2 or equivalent can be connected (see page 40).

11 MIC IN (microphone input) (+48 V) connector (XLR type, 5-pin, female)

Connect the supplied stereo microphone to this connector. The power (+48 V) is supplied via this connector.

12 Shoulder pad

Raise the shoulder pad fixing lever to adjust the position in the front-to-rear direction. Adjust the position for maximum convenience when operating the unit on your shoulder.

For details of the adjustment, see “Adjusting the Shoulder Pad Position” on page 39.

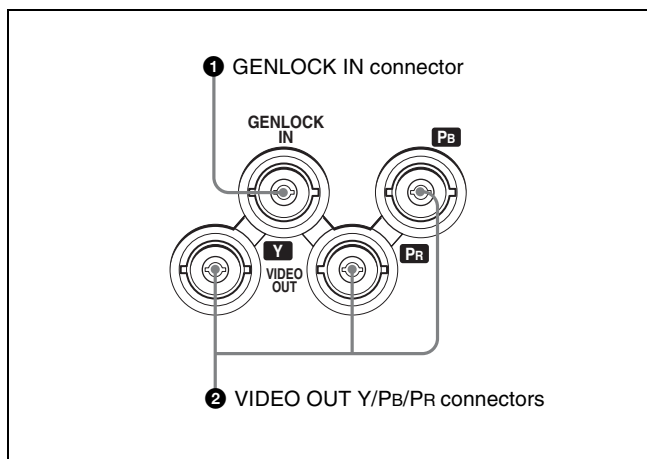
1 Video output and timecode connectors**1 GENLOCK IN (genlock signal input) connector (BNC type)**

Input an SD or HD reference signal when applying a genlock to the camera, or synchronizing timecode to an external source. Use the GENLOCK page of the MAINTENANCE menu to carry out phase adjustment of the horizontal synchronization signal for genlock.

Note

The subcarrier phase cannot be adjusted.

2 VIDEO OUT (video output) Y/PB/PR connectors (BNC type)

Output component video signals (Y/PB/PR) for a video monitor.

Connect a video monitor with component video signal input connectors to check the video being shot by the camera. You can also monitor VDR playback video.

You can select HD Y/PB/PR or SD Y/PB/PR signal output on the OUTPUT page of the OPERATION menu. For details, see “Selecting the Output Signals” on page 140.

Note

No video signals are output when ANA V OUT SAVE on the CAM CONFIG page of the MAINTENANCE menu is set to ON and the connection to this connector is not terminated correctly. Video signals are always output from this connector when ANA V OUT SAVE is set to OFF.

Rear

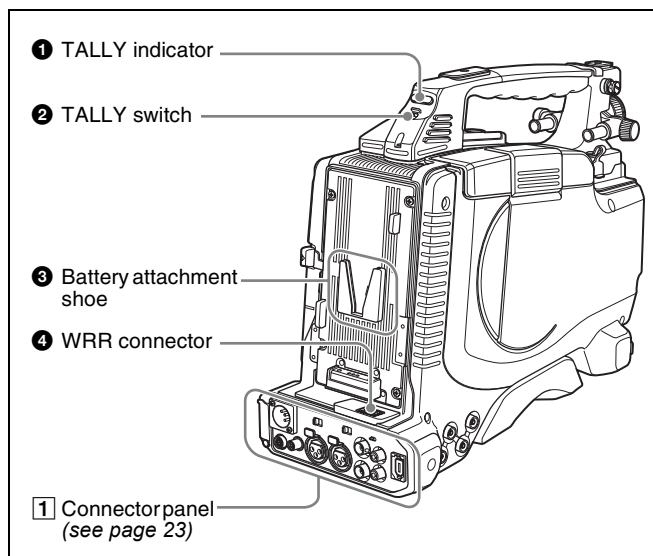

1 TALLY (back tally) indicator (red)

Lights up during recording. It will not light if the TALLY switch is set to OFF. This indicator also flashes to indicate warnings (see page 18) in the same manner as the REC/TALLY indicator in the viewfinder.

For details, see “Operation Warnings” on page 168.

2 TALLY switch

Set to ON to activate the TALLY indicator function.

3 Battery attachment shoe

Attach a BP-GL95/GL65/L60S/L80S Battery Pack. Alternatively, you can attach an AC-DN2B/DN10 AC Adaptor to operate the camcorder on AC power supply.

For details about how to attach the battery or AC adaptor, see “Preparing a Power Supply” on page 31. For information about attaching a synthesized tuner, see “Attaching a UHF Synthesized Tuner” on page 42.

Note

For your safety, and to ensure proper operation of the camcorder, Sony recommends the use of the following battery packs: BP-GL95, BP-GL65, BP-L60S, and BP-L80S.

4 WRR connector (7-pin)

Connect a CA-WR855 Camera Adaptor with attached WRR-855 UHF Synthesized Tuner.

For details, see “Attaching a UHF Synthesized Tuner” on page 42.

1 Connector panel

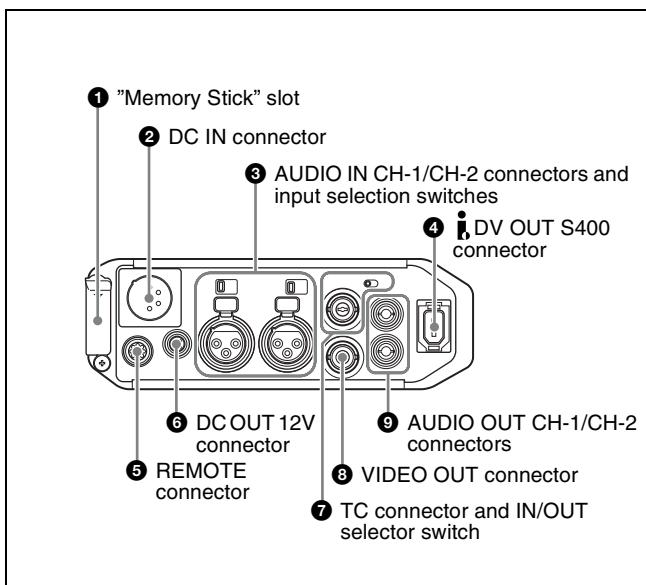

1 “Memory Stick” slot

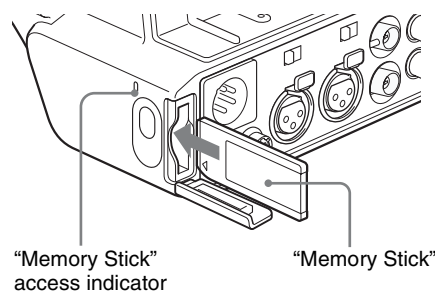

Insert a “Memory Stick”. The “Memory Stick” access indicator lights up when the “Memory Stick” is being accessed for reading or writing.

For details about how to insert a “Memory Stick”, see “To insert a “Memory Stick”” on page 146.

For details about the types of “Memory Stick”, see “About a “Memory Stick”” on page 178.

Note

Do not remove a “Memory Stick” while the “Memory Stick” access indicator is lit. Doing so may cause a loss of data.

2 DC IN (DC power input) connector (XLR type, 4-pin, male)

To operate the camcorder using an AC power supply, connect an AC-550 AC Adaptor with the DC output cable supplied with the adaptor.

3 AUDIO IN CH-1/CH-2 (audio input channel 1/2) connectors (XLR type, 3-pin, female) and input selection switches

Connect other audio equipment or external microphone. Set the input selection switches as shown below according to the microphone or equipment.

LINE (left position): For connecting an external audio signal source such as a stereo amplifier

MIC (center position): For connecting any microphone other than 48 V microphone

MIC +48V ON (right position): For connecting a 48 V microphone

Signals input to the AUDIO IN CH-1 connector can be recorded on audio channels 1 and 3. Similarly, signals input to the AUDIO IN CH-2 connector can be recorded on audio channels 2 and 4. ¹⁾

1) When the AUDIO IN (CH-1/CH-2/CH-3/CH-4) switches on the side control panel are set to "REAR" or "R".

Note

If MIC +48V ON is selected for a microphone other than 48 V microphone, the microphone may be damaged.

4 i.LINK DV OUT S400 connector (6-pin, IEEE 1394 compliant)

Connect to a device supporting the DV format or a computer, using an i.LINK cable (DV cable).

Notes

- If video and audio signals are not output from the external device connected to the i.LINK DV OUT S400 connector, disconnect the i.LINK cable (DV cable) and then reconnect it, making sure that it is firmly seated.
- When you connect the camcorder and other equipment, such as a hard disk drive, with an i.LINK interface to a computer with i.LINK connectors, turn off the power of the computer, the other equipment, and the camcorder before connecting them using the i.LINK cable (DV cable). If a bus-powered type ¹⁾ hard disk drive or similar equipment is connected while the computer is powered on, electric current flows into the camcorder because of the high voltage caused by the load shift of the computer power, and this may cause a malfunction.

1) Equipment that can be powered through i.LINK cable (DV cable)

5 REMOTE connector (8-pin)

Connect an RM-B150/B750 Remote Control Unit, which makes it possible to control the camcorder remotely.

Note

Before connecting/disconnecting the Remote Control Unit to/from the camcorder, be sure to turn off the camcorder POWER switch.

6 DC OUT 12V (DC power output) connector (4-pin, female)

Supplies power for a WRR-861/862 UHF Synthesized Tuner (optional) (maximum 0.2 A).

Do not connect any equipment other than the UHF synthesized tuner.

7 TC (timecode) connector (BNC type) and IN/OUT selector switch

• IN/OUT selector switch: IN

To apply an external lock to the timecode, input the reference timecode.

• IN/OUT selector switch: OUT

To lock the timecode of an external VTR to the timecode of this unit, connect this connector to the external VTR's timecode input connector.

8 VIDEO OUT (video output) connector (BNC type)

Outputs a video signal for a video monitor. When the output signal is composite, setting menus, timecode, or shot data can be superimposed on the camera output video depending on the menu settings, and you can view them on the monitor screen. To lock the timecode of an external device to the timecode of this unit, connect the genlock signal input connector of the external device to this connector.

Notes

- The subcarrier phase cannot be adjusted.
- No video signals are output when ANA V OUT SAVE on the CAM CONFIG page of the MAINTENANCE menu is set to ON and the connection to this connector is not terminated correctly. Video signals are always output from this connector when ANA V OUT SAVE is set to OFF.

9 AUDIO OUT CH-1/CH-2 (audio output channel 1/2) connectors (phono jacks)

Output the audio signals being recorded or played back. Connect to a stereo amplifier or video monitor's audio input connectors.

VCL-719BXS Auto Focus Lens (Supplied with the PDW-F335K)

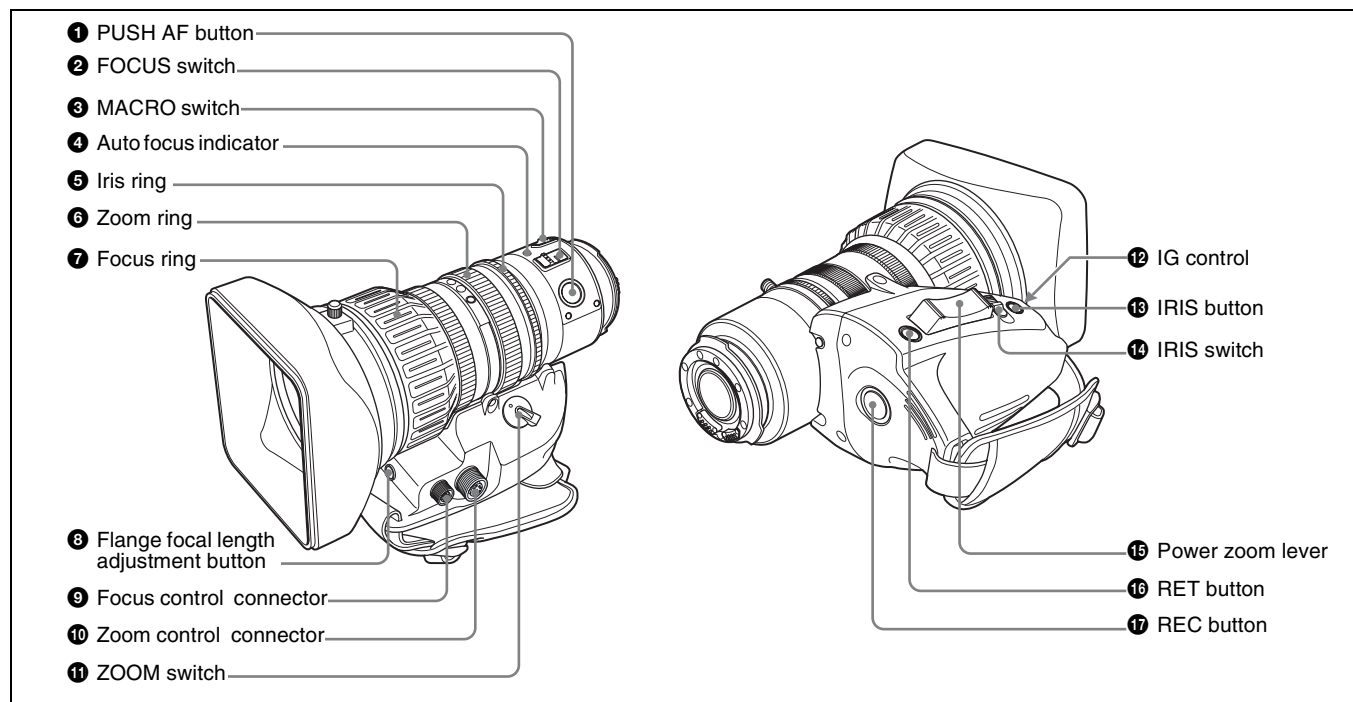

1 PUSH AF (auto focus) button

When the focus adjustment is in the manual mode, by pressing this button you can use the auto focus for an instantaneous adjustment to the subject.

When the button is pressed, the auto focus operates until the image is in focus, then disengages.

Even when the FOCUS switch is set to A (auto), by pressing this button, you can restart the auto focus.

2 FOCUS switch

Select the method of focusing.

A (auto): The auto focus function is constantly active.

While the auto focus is operating, the auto focus indicator lights green. Even with the switch in the A position, you can manually adjust the focus by operating the focus ring.

M (manual): The manual mode allows focusing adjustment with the focus ring.

In manual mode, auto focus adjustment is also possible, by pressing the PUSH AF button.

3 MACRO switch

When this switch is in the ON position, the macro mode is enabled, allowing focusing over the whole range (5 cm¹⁾ to ∞) including the macro range (from 5 cm¹⁾ to 90 cm from the front of the lens).

This operation is independent of whether the focus adjustment mode is auto or manual.

In the macro range, the auto focusing speed is lower.

1) At the wide-angle setting

4 Auto focus indicator

This lights green while the auto focus function is operating.

During flange focal length adjustment, it flashes orange or green.

If an error occurs, it lights red.

For details of flashing during flange focal length adjustment, see “Adjusting the Flange Focal Length” on page 35.

5 Iris ring

For manual iris adjustment, set the IRIS switch to the M (manual) position, then turn this ring.

6 Zoom ring

For manual zoom adjustment, set the ZOOM switch to the MANU. position, then turn this ring.

7 Focus ring

Turn this ring to adjust the focus.

This ring can be turned endlessly in both directions. The faster you turn, the faster the focusing mechanism operates, to minimize the amount of turning required for focusing.

8 Flange focal length adjustment button

Press this to adjust the flange focal length (the distance from the lens mounting flange plane to the focusing plane).

For details of flange focal length adjustment, see “Adjusting the Flange Focal Length” on page 35.

9 Focus control connector (6-pin)

Connecting an optional focus servo controller allows remote control of focusing.

10 Zoom control connector (8-pin)

Connecting an optional zoom servo controller allows remote control of zooming.

11 ZOOM switch

Select the method of zoom operation.

SERVO: Power zoom. Operate the zoom with the power zoom lever.

MANU. (manual): Manual zoom. Operate the zoom with the zoom ring.

12 IG (iris gain) control

Remove the rubber cap, and turn the knob inside, to adjust the gain for auto iris adjustment.

Note

This is set to an appropriate value when the unit is shipped. It does not normally require any adjustment.

13 IRIS button

When the IRIS switch is in the M position for manual adjustment, press this button for an instantaneous auto adjustment.

The iris is automatically adjusted while the button is held down.

14 IRIS switch

Select the method of iris adjustment.

A (auto): Auto mode. The iris is adjusted automatically.

M (manual): Manual mode. Adjust the iris with the iris ring.

15 Power zoom lever

This is enabled when the ZOOM switch is in the SERVO position. Press the W end for wide-angle and the T end for telephoto.

Press the lever harder for a faster zoom action.

Notes on auto focus

- When an auto focus lens is mounted, in the auto focus mode a frame appears in the center of the viewfinder screen indicating the auto focus area. Place the subject on which you want to focus within this frame.
- In the following cases, it may be difficult to focus on the subject. If this does happen, use manual focusing.
 - If the subject has no contrast
 - If the subject is moving rapidly
 - When shooting point light sources, under street lighting or at night
 - When there are very bright objects close to the subject
 - When shooting through a glass window
- On the LENS page of the MAINTENANCE menu, by changing the AF DETECT AREA setting from

“CENTER” to “FULL”, instead of focusing only on the center portion of the screen, the whole screen image is used for focusing. In this case, the auto focus area frame does not appear.

- If there are a number of objects within the screen at close and far range, the focus may not be on the intended subject. In this case, with the subject on which you want to focus in the center of the screen, press the PUSH AF button.
- After focusing with the PUSH AF button, if you operate the zoom or adjust the iris, the depth of field may become shallower, losing crisp focus. In such cases, press the PUSH AF button once more.
- If you focus at wide-angle then zoom to telephoto, the subject may no longer be in focus.
- The auto focus function does not operate while using the slow shutter mode (4F or higher).

Note on zoom speed

Depending on the shooting distance, the zoom speed may fall as the lens approaches the telephoto end.

16 RET (return video) button

Use this to check the video. If you press this while recording by the internal VDR is paused, the last few seconds recorded appear in the viewfinder (recording review).

For details, see “Checking the Last Two Seconds of the Recording (Recording Review)” on page 75.

Pressing this button (single click) during recording records a shot mark 1, and double-clicking records a shot mark 2.

For details, see “Recording Shot Marks” on page 65.

17 REC (recording start) button

Use this to start and stop recording. Press once to start recording, then press once more to stop.

DXF-20W Viewfinder

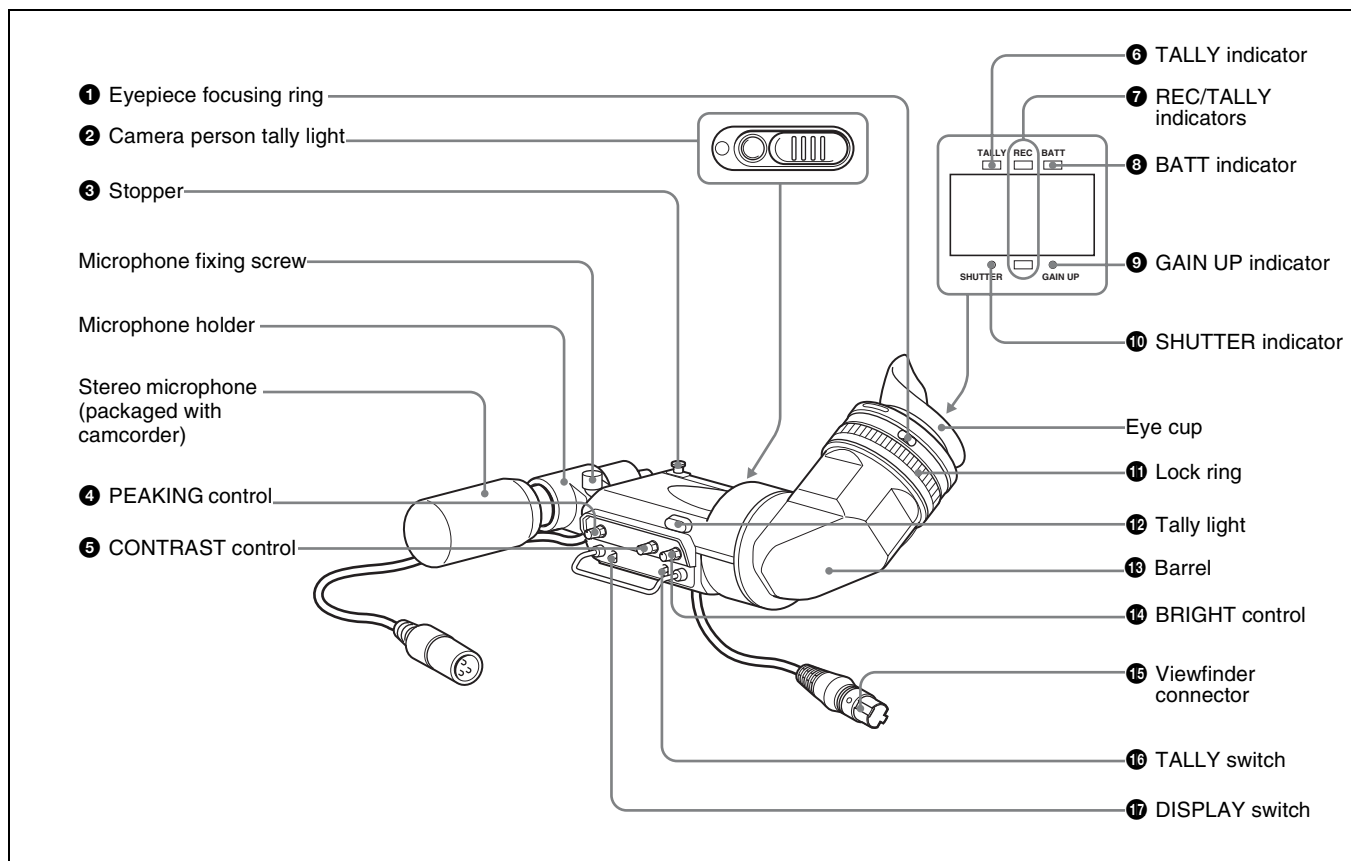

1 Eyepiece focusing ring

Adjusts the viewfinder focus to match your eyesight (*see page 37*).

2 Camera person tally light

Lights while the camcorder is recording. To start recording with your eye off the viewfinder, open the slide window. This indicator flashes when the remaining battery capacity or remaining disc capacity is low.

3 Stopper

Lift up when detaching the viewfinder (*see page 37*).

4 PEAKING control

Adjusts the outline intensity of the viewfinder image (*see page 37*).

5 CONTRAST control

Adjusts the contrast of the viewfinder image (*see page 37*).

6 TALLY (tally) indicator (green)

Flashes when the camcorder is in Interval Rec mode. Flashing quickens while you are shooting in Interval Rec mode.

For details on Interval Rec mode, see “Time-lapse Video Recording (Interval Rec Function)” on page 66.

7 REC/TALLY (recording/tally) indicators (red)

Function as follows.

- Begin flashing when you press the REC button on the camcorder or on the lens until recording starts, then stay on continuously during recording.
- Indicate a fault (*see page 168*).

On the CAM CONFIG page of the MAINTENANCE menu, you can select that the lower indicator also lights.

8 BATT (battery) indicator (red)

Lights up when the remaining battery capacity is low.

9 GAIN UP indicator (orange)

Lights up when the gain is 3 dB or more.

10 SHUTTER indicator (red)

Lights up when the SHUTTER switch (*page 13*) is ON.

11 Lock ring

To directly view the screen, turn this ring counterclockwise, to align the orange marks on the lock ring and the barrel of the viewfinder, and remove the eyepiece.

12 Tally light

When the TALLY switch is in the HIGH (high intensity) or LOW (low intensity) position, this operates in the same way as the REC/TALLY indicators.

13 Barrel

You can rotate this for convenience.

Note

The position of the image may change, as a result of the earth's magnetic field.

14 BRIGHT (brightness) control

Adjusts the brightness of the viewfinder image (*see page 37*).

15 Viewfinder connector (20-pin)

Connect to the VF connector (*see page 12*).

16 TALLY switch

Set to the HIGH (high-intensity) or LOW (low-intensity) to use the tally light.

17 DISPLAY switch

Set to ON when you want to display text information on the viewfinder screen.

Status Display on the Viewfinder Screen

The viewfinder screen displays not only the video picture but also characters and messages indicating the camcorder settings and operating status, a center marker, a safety zone marker, etc.

When the menu screen is not displayed and the DISPLAY switch is set to ON, the items for which an ON setting was made on the VF DISP 1 or VF DISP 2 page of the OPERATION menu or with related switches are displayed at the top and bottom of the screen.

The messages that give details of the settings and adjustment progress and results can also be made to appear for about 3 seconds while settings are being changed, during adjustment, and after adjustment.

For details about the display item selection, see "Selecting the Display Items" on page 135.

For details about setting change and adjustment progress messages, see "Change Confirmation/Adjustment Progress Messages" on page 136.

For details about marker display, see "Setting the Marker Display" on page 136.

Layout of the status display on the viewfinder screen

All items that can be displayed on the viewfinder screen are shown below.

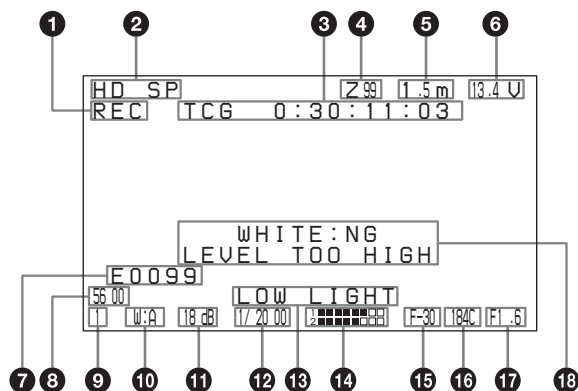
**1 VDR operation indicators**

VDR operation is displayed as follows:

REC: During recording

PLAY: During playback

CONT (lit): Continuous recording to extend the previous clip is possible.

CONT (flashing): CLIP CONT REC is ON, and a new clip will be created and recorded.

||: During pause of recording/playback

▶▶: During high-speed playback or forward jump to clips

◀◀: During reverse high-speed playback or reverse jump to clips

2 Recording format

Indicates the current recording format.

3 Timecode

Indicates the elapsed recording/playback time, timecode, user bits or other information selected by the DISPLAY switch (*see page 28*).

4 Zoom position

Indicates the zoom position of the zoom lens in the range from 0 to 99.

5 Focus

Indicates the focusing distance corresponding to the focus ring when an auto focus lens is mounted, and the focus adjustment mode is set to manual.

The displayed resolution is as shown below.

- 10 m or less (including the macro area): 0.1 m
- 10 m to 100 m: 1 m
- 100 m to 200 m: 10 m
- 200 m to infinite distance: 50 m

6 Power source voltage/battery remaining capacity

When the unit is powered from a battery pack or AC adaptor attached to the battery attachment shoe, indicates the remaining capacity of the power source voltage. When

the unit is powered from an external battery (a battery connected to the DC IN connector), indicates the power source voltage.

When the DISP BATT REMAIN item is set to “INT” on the VF DISP 1 page of the OPERATION menu, the battery voltage is not indicated.

However, when the Anton Bauer intelligent battery system or the BP-GL95/GL65 Battery Pack is used, the remaining battery capacity is automatically detected and indicated in steps of 10%.

- Until the remaining battery capacity is reduced to 40%, the indications MAX, 90%, 80%...40% are displayed for three seconds in the viewfinder each time the remaining battery capacity reduces by 10%.
- When the remaining battery capacity is less than 40%, the indication is displayed all the time.
- When the remaining battery capacity is less than 10%, the indication flashes. When the remaining battery capacity is reduced further, the “LOW” flashes.

7 Clip list name

Displays the name (E0001 to E0099) of the currently selected clip list.

8 5600 indicator

Appears when the electric color temperature filter function is on.

9 Filter

Indicates the currently selected filter type.

10 White balance memory

Indicates the currently selected white balance automatic adjustment memory.

A: Displayed when the WHITE BAL switch is set to A.

B: Displayed when the WHITE BAL switch is set to B.

P: Displayed when the WHITE BAL switch is set to PRST or when the preset button on an RM-B150 has been pushed.

T: Displayed when ATW is being used.

11 Gain value

Indicates the gain value (in dB) of the video amplifier, as set by the GAIN switch.

12 Shutter speed

Indicates the shutter speed or the shutter mode. However, if the SHUTTER switch (see page 13) is set to OFF, nothing is displayed.

For details of the displayed shutter speed, see “Setting the Electronic Shutter” on page 57.

13 Operation/alarm message display area

For details, see “Operation/alarm messages” on page 169.

14 Audio level

Indicates the level of audio channel 1 and channel 2. The peak indication of the VDR level meter is related as follows to the audio level.

For example, the level of the internal 1 kHz sine wave signal is -20 dB, causing the six bars from the left to light.

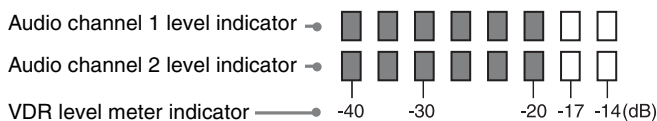

15 Remaining disc capacity

Indicates the remaining recording time (in minutes) of the disc.

Examples of remaining recording time indication

| Indication | Remaining recording time |
|------------|--------------------------|
| 90 < | More than 90 minutes |
| 90 - 85 | 90 to 85 minutes |
| 85 - 80 | 85 to 80 minutes |
| ⋮ | ⋮ |
| 20 - 15 | 20 to 15 minutes |
| 15 - 10 | 15 to 10 minutes |
| 10 - 5 | 10 to 5 minutes |
| 5 - 0 | 5 to 0 minutes |
| No display | 0 minute |

As shown below, dual-layer discs (PFD50DLA) allow longer recording times than those in the above table.

| Indication | Remaining recording time |
|------------|--------------------------|
| 250 < | More than 250 minutes |
| 240 < | More than 240 minutes |
| 230 < | More than 230 minutes |

16 Remaining clips display

Displays the remaining number of clips that can be recorded. The display flashes once per second when the number of remaining clips is less than 10.

17 Iris setting/auto iris override

Indicates the F value (iris setting) of the lens. Also, the auto iris override is displayed using two squares which appear in the upper and lower parts respectively.

For details, see “Adjusting the Iris” on page 59.

18 Setting change and adjustment progress message display area

For details, see “Change Confirmation/Adjustment Progress Messages” on page 136.

Attaching and Replacing the Lithium Battery

This camcorder uses a lithium battery to retain stored data. When using the camcorder for the first time, be sure to attach the supplied lithium battery (CR2032). The camcorder will not operate correctly without this lithium battery. After attaching the lithium battery, set the date and time of the internal clock (see “Setting the Date and Time of the Internal Clock” on page 34).

Note

Use CR2032 lithium batteries only. Other types of lithium battery may come loose when the camcorder is subjected to vibrations. If you have difficulty finding CR2032 lithium batteries, contact your Sony dealer.

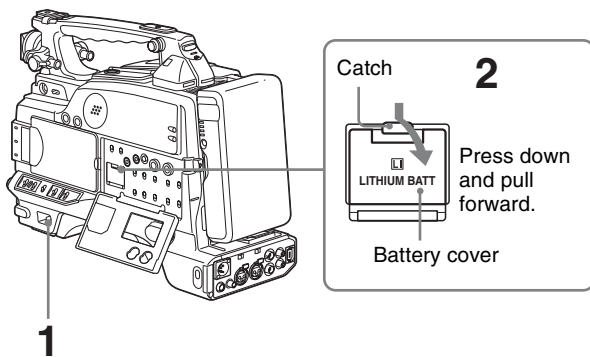

- 1 Set the POWER switch to OFF.
- 2 Press down the catch at the top of the battery cover and open the cover.

- 3 Take out the lithium battery.

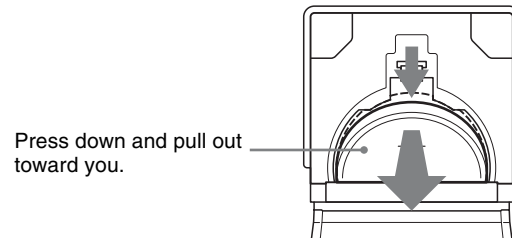

- 4 Reverse step 3 to insert a replacement lithium battery. Make sure that the + symbol on the battery is facing you.
- 5 Close the battery cover.

WARNING

Battery may explode if mistreated.
Do not recharge, disassemble or dispose of in fire.

CAUTION

Danger of explosion if battery is incorrectly replaced.
Replace only with the same or equivalent type recommended by the manufacturer.
Dispose of used batteries according to the manufacturer's instructions.

Service life of the lithium battery

When the lithium battery's voltage falls, the lithium battery low voltage warning appears on the LCD monitor (see page 16). If this warning appears, replace the lithium battery (CR2032) within three or four days. The lithium battery has an average service life of about one year.

Preparing a Power Supply

The following power supplies are recommended for the camcorder.

- BP-GL95/GL65/L60S/L80S Lithium-ion Battery Pack
- AC power using the AC-DN2B/DN10 AC adaptor

Using a Battery Pack

When a BP-GL95/GL65/L60S/L80S Battery Pack is used, the camcorder will operate continuously for the time shown below.

| Model name | Operating time |
|------------|---------------------|
| BP-GL95 | Approx. 160 minutes |
| BP-GL65 | Approx. 100 minutes |
| BP-L60S | Approx. 100 minutes |
| BP-L80S | Approx. 130 minutes |

Note

The battery pack operating time depends on the frequency of use of the battery pack, and the ambient temperature when used.

Before use, charge the battery pack with a charger suitable for each battery.

For details on the battery charging procedure, refer to the battery charger operation manual.

Note on using the battery pack

A warm battery pack may not be able to be fully recharged.

To attach the battery pack

- 1 Press the battery pack against the back of the camcorder, aligning the line on the side of the battery pack with the matching line on the camcorder.

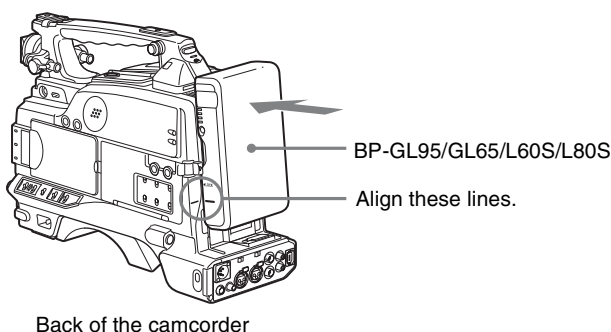

- 2 Slide the battery pack down until its "LOCK" arrow points at the matching line on the camcorder.

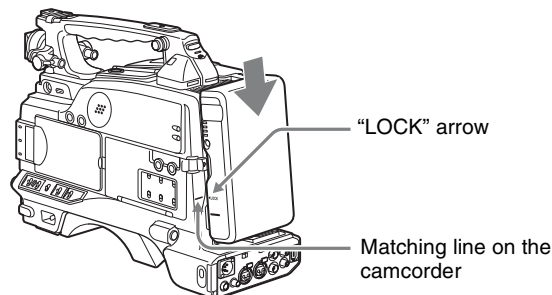

Note

If the battery pack is not attached correctly, the terminal may be damaged.

To detach the battery pack

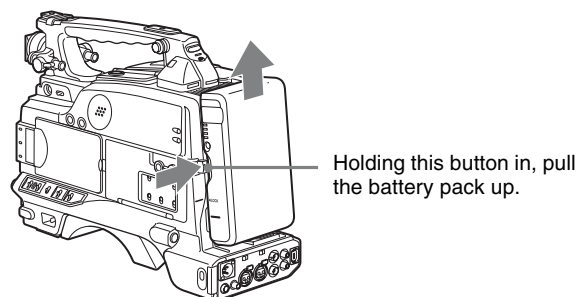

Notes

- During recording and playback (while the ACCESS indicator is lit), be careful never to remove the battery pack.
- Make sure to power the camcorder off before replacing the battery pack.

Using an AC Adaptor

When using the AC-DN10 AC adaptor

Mount an AC-DN10 on the camcorder in the same way as a battery pack, then connect to the AC power supply. The AC-DN10 can supply up to 100 W of power.

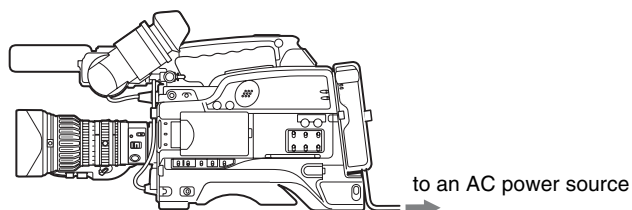

Setting the Area of Use and the Frame Frequency

Using the Unit for the First Time

The area of use and the frame frequency are not factory preset. Before using this unit, you need to set these items. (You cannot use the unit without setting these items.)

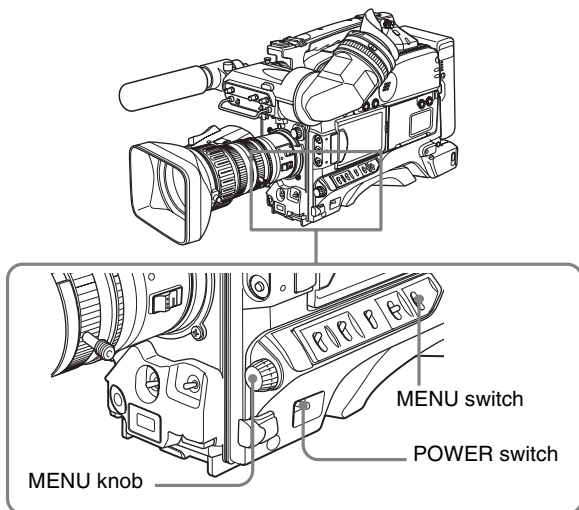

- 1 Set the POWER switch to the ON position.

The screen for setting the area of use appears in the viewfinder.

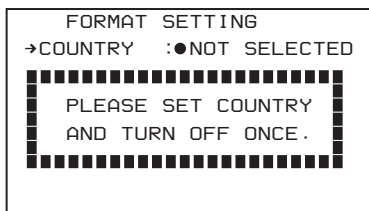

- 2 Press the MENU knob.

The ● mark on the left of “NOT SELECTED” changes to a ? mark, and you can now select the area of use.

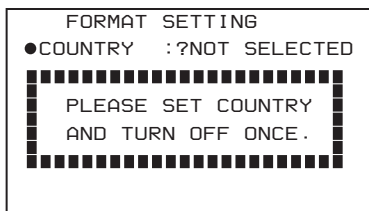

- 3 Turn the MENU knob to display the desired area of use.

| Setting | Area of use |
|---------------|---|
| NTSC (J) AREA | NTSC area (Japan) a) |
| NTSC AREA | NTSC area (for areas other than Japan) b) |
| PAL AREA | PAL area c) |

- a) The composite signal output from this unit is an NTSC signal with no Setup. The frame frequency can be selected as any of 60I, 30P, or 23.98P.
- b) The composite signal output from this unit is an NTSC signal with Setup (7.5 IRE). The frame frequency can be selected as any of 60I, 30P, or 23.98P.
- c) The composite signal output from this unit is a PAL signal. The frame frequency can be selected as either 50I or 25P.

- 4 Set the POWER switch to OFF, then once again to ON.

The unit is now ready for use.

Proceed to the next operation: setting the frame frequency.

Setting the Frame Frequency

- 1 Hold down the MENU knob, and move the MENU switch to the ON position.

The TOP menu appears.

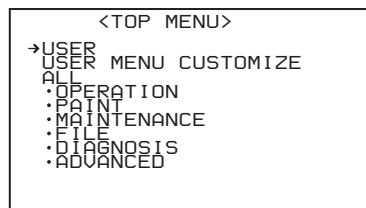

- 2 Turn the MENU knob to move the ► mark to “OPERATION”, then press the MENU knob.

The CONTENTS page of the OPERATION menu appears.

You can move to another page when a ? mark appears.

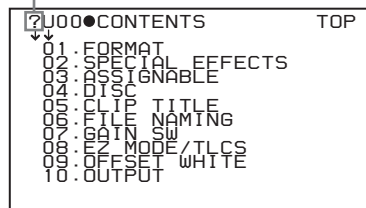

- 3 Press the MENU knob, then turn the knob to move the ► mark to “FORMAT”.

- 4 Press the MENU knob.

The FORMAT page appears.

```
?001●FORMAT          TOP
SYSTEM                : 50I
REC FORMAT           : MPEG HD
BIT RATE (HD)        : SP
AUDIO CH (HD)        : 4CH
ASPECT RATIO(DU)    : 16:9
COUNTRY              : PAL AREA
```

- 5** To change the area of use, press and turn the MENU knob to move the ► mark to “COUNTRY”, then press the MENU knob.

```
001●FORMAT          TOP
SYSTEM                : 50I
REC FORMAT           : MPEG HD
BIT RATE (HD)        : SP
AUDIO CH (HD)        : 4CH
ASPECT RATIO(DU)    : 16:9
→COUNTRY             : ●PAL AREA
```

The ► mark beside “COUNTRY” changes to a ● mark, and the ● mark beside the setting value changes to a ? mark.

- 6** Turn the MENU knob to display the desired area of use (see step 3 in the previous section).

```
001?FORMAT          TOP
POWER OFF -> ON!!
SYSTEM                : 50I
REC FORMAT           : MPEG HD
BIT RATE (HD)        : SP
AUDIO CH (HD)        : 4CH
ASPECT RATIO(DU)    : 16:9
●COUNTRY             : ?PAL AREA
```

- 7** Refer to steps 5 and 6, and select the frame frequency.

If NTSC (J) AREA/NTSC AREA has been selected

| Item | Description | Setting |
|--------|--------------------------|----------|
| SYSTEM | Set the frame frequency. | 60I a) |
| | | 30P b) |
| | | 23.9P c) |

- a) More precisely 59.94I.
- b) More precisely 29.97P.
- c) More precisely 23.98P.

If PAL AREA has been selected

| Item | Description | Setting |
|--------|--------------------------|---------|
| SYSTEM | Set the frame frequency. | 50I |
| | | 25P |

- 8** Refer to steps 5 and 6, and set the recording format and other items as required.

| Item | Description | Setting |
|--------------|--|--------------------|
| REC FORMAT | Set the recording format. | MPEG HD |
| | | DVCAM |
| BIT RATE | Set the recording mode if MPEG HD has been selected. | HQ (high quality) |
| | | SP (standard play) |
| | | LP (long play) |
| ASPECT RATIO | Set the aspect ratio if DVCAM has been selected. | 16:9 |
| | | 4:3 |
| AUDIO CH | Set the number of audio recording channels if MPEG HD has been selected. | 2CH |
| | | 4CH |

- 9** Set the POWER switch to OFF, then once again to ON.

Setting the Date and Time of the Internal Clock

You can set the date and time of the internal clock. The date and time set here are reflected in timecode.

(How to select an item in the menu screen: Turn the MENU knob to move the ► mark to the desired item.)

- 1 Display the TIME/DATE page of the OPERATION menu, and press the MENU knob.

For details on menu operations, see “Basic Menu Operations” on page 130.

| | |
|----------------|---------|
| ?020●TIME/DATE | TOP |
| →ADJUST | :▷ EXEC |
| HOUR | : 12 |
| MIN | : 00 |
| SEC | : 58 |
| YEAR | : 00 |
| MONTH | : 07 |
| DAY | : 31 |

- 2 Select ADJUST, and press the MENU knob.

The TIME ADJUST screen appears.

- 3 Select a desired setting item, and press the MENU knob.

You can set the following items in the TIME ADJUST screen.

| Item | Description |
|-------|-------------------------|
| HOUR | Sets the hour value. |
| MIN | Sets the minutes value. |
| SEC | Sets the seconds value. |
| YEAR | Sets the year. |
| MONTH | Sets the month. |
| DAY | Sets the day. |

- 4 Turn the MENU knob to select the desired setting, and press the MENU knob.
- 5 Repeat steps 3 and 4 until you have set all of the desired items.
- 6 When you are finished making settings, select OK, and press the MENU knob.

The internal clock is set with the date and time set in steps 3 to 5. The TIME/DATE page of the OPERATION menu appears again. The time set in the TIME ADJUST screen is displayed.

To cancel the setting

Before executing step 6, select ESC and press the MENU knob.

All the settings so far made are discarded and the TIME/DATE page appears again.

Preparing the Lens

Mounting the Lens

First power off the unit, and then mount the lens using the following procedure.

(To mount a 1/2-inch type lens, carry out steps 1 to 3.)

For information about using the lens, refer to the operating instructions for the lens.

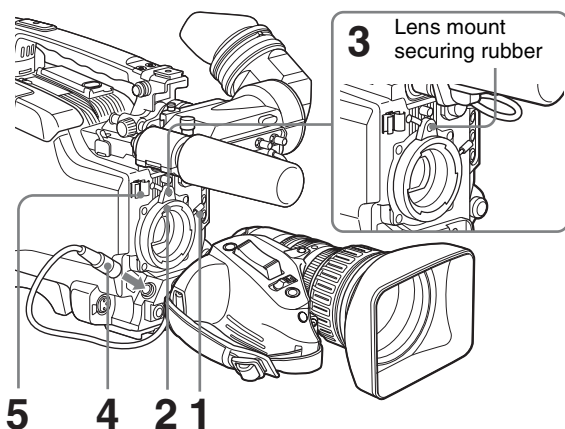

- 1 Push the lens locking lever up and remove the lens mount cap from the lens mount.
- 2 Align the center pin on the lens with the center slot in the lens mount, and insert the lens into the mount.
- 3 Holding the lens in place, push the lens locking lever down to lock the lens.

Caution

If the lens is not firmly locked, it may come off while the camcorder is being used. This could cause a serious accident. Make sure the lens is firmly locked. It is recommended that the lens mount securing rubber be put on the lens locking lever as illustrated above.

Note

Mounting a 2/3-inch type lens requires a 2/3-inch type lens mount adaptor.

- 4 If a 2/3-inch type lens has been mounted, connect the lens cable to the LENS connector.

Note

Connecting the lens cable to the LENS connector when the camcorder is powered may cause a malfunction of the camcorder or the lens. Before connecting the lens cable, be sure to check that the camcorder is powered off.

- 5 Secure the lens cable with the cable clamps.

Adjusting the Flange Focal Length

If the focus is not precisely correct at the telephoto and wide-angle ends of zoom operations, adjust the flange focal length (the distance from the lens mounting flange plane to the focusing plane).

Once adjusted, no further adjustment is required unless the lens is changed.

When carrying out the adjustment, use the supplied flange focal length adjustment chart as the subject.

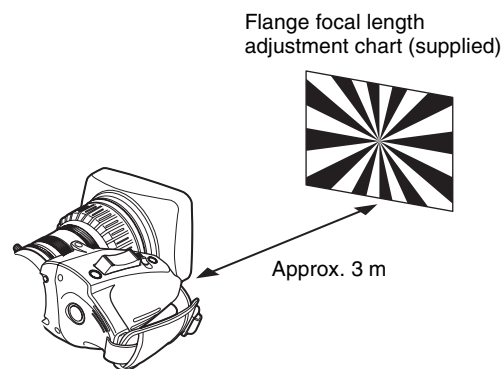

Note

If you use a subject with insufficient contrast, or move the camera or subject during adjustment, this will cause an adjustment error.

Carrying out the adjustment

When using the VCL-719BXS Auto Focus Lens
With the VCL-719BXS lens supplied with the PDW-F335K, zoom and focus operations automatically adjust the flange focal length.

Flange focal length adjustment button

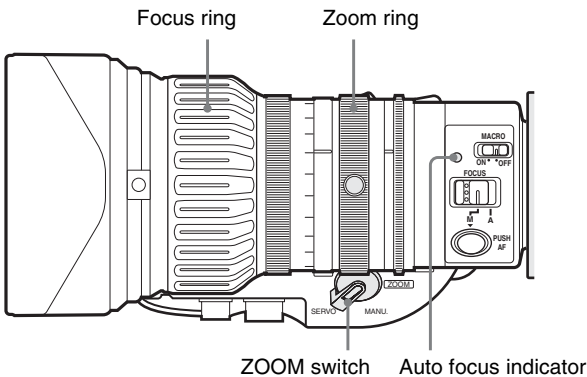
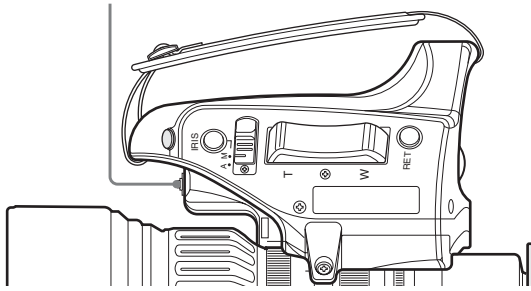

- 1 Set the iris to manual.
- 2 Open the iris, position the supplied flange focal length adjustment chart approximately 3 meters away from the camera, and arrange the lighting to obtain a satisfactory video output.
- 3 Loosen the fixing screws on the F.f or F.B ring (flange focal length adjustment ring).
- 4 Use manual or power zoom to set the lens to telephoto.
- 5 Point the camera at the chart by turning the focus ring and focus on the chart.
- 6 Set the zoom ring to wide angle.
- 7 Turn the F.f or F.B ring until the chart is in focus, being careful not to disturb the focus ring.
- 8 Repeat steps 4 to 7 until the chart stays in focus ring.
- 9 Tighten the F.f or F.B ring fixing screws.

- 1 Open the iris, position the supplied flange focal length adjustment chart approximately 3 meters away from the camera, and arrange the lighting to obtain a satisfactory video output.
- 2 Set the ZOOM switch to SERVO (power zoom mode).
- 3 Hold down the flange focal length adjustment button for 3 seconds.

The auto focus indicator flashes orange, and the flange focal length adjustment starts.

During adjustment

The auto focus indicator flashes alternately orange and green.

The message "AUTO FB EXECUTING" appears on the viewfinder screen.

If the adjustment completes correctly

The auto focus indicator goes off, and the message on the viewfinder screen changes to "FB: OK".

If the flange focal length adjustment does not complete correctly

The auto focus indicator lights red.

Check the subject and lighting conditions, and repeat the adjustment.

When using a non-auto focus lens

Read the instruction manual for the lens in use as well.

Adjusting the Viewfinder

Depending on the eyesight of the operator — whether longsighted or shortsighted — the optimal position of the viewfinder image varies. Adjusting brightness, contrast, and so on, improves the visibility of the viewfinder screen. Although these adjustments may make the viewfinder image clearer, they have no effect on the output video signal from the camcorder.

- Be sure to power off this unit before plugging the viewfinder connector into the VF connector on this unit. If the connector is plugged in while the power is on, the viewfinder may not operate correctly.
- Make sure that the viewfinder connector is pushed fully into the VF connector on the unit. If the connector is not firmly connected, the image may break up, or the tally light may not operate properly.

For details, contact your Sony dealer.

Detaching the Viewfinder

Remove any microphone from the viewfinder beforehand.

- 1 Power off this unit, then unplug the viewfinder connector from the VF connector.

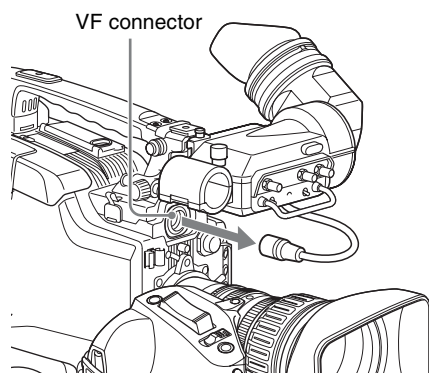

- 2 Loosen the viewfinder left-to-right positioning ring ①, and with the stopper raised ②, detach the viewfinder ③.

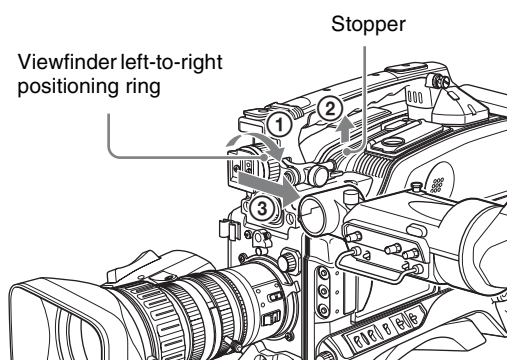

To attach the viewfinder

Reverse the detaching procedure. (Note that it is not necessary to raise the stopper.)

Note

Note the following points when mounting the viewfinder.

Adjusting the Viewfinder Position

To adjust the viewfinder left-to-right position, loosen the left-to-right positioning ring, and to adjust the front-to-back position, loosen the front-to-back positioning knob.

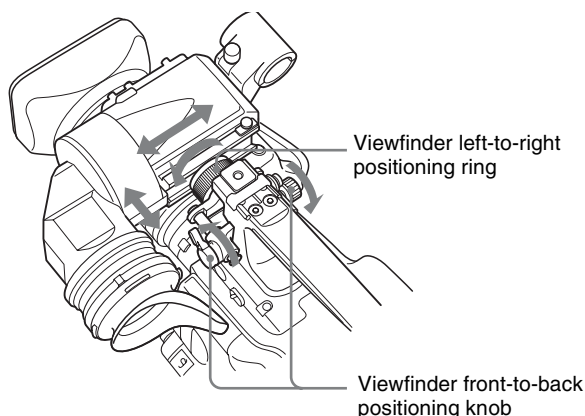

Note

When the viewfinder is attached, do not leave the camera (or the camcorder) with the eyepiece facing the sun. Direct sunlight can enter through the eyepiece, be focused in the viewfinder and cause fire.

Adjusting the Eyepiece Focus and the Screen (Brightness, Contrast, and Outline Emphasis)

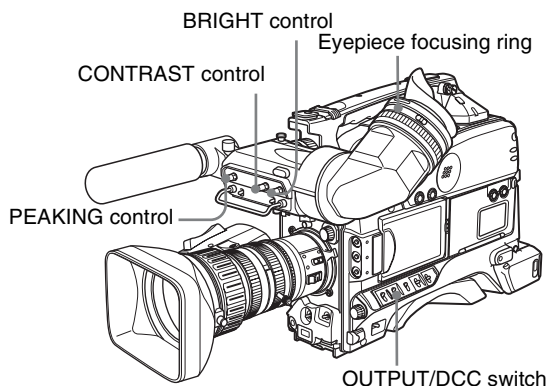

To adjust the eyepiece focus

First focus the image with the lens, then adjust the eyepiece focusing knob or eyepiece focusing ring to get the clearest viewfinder image for your eyesight. The visual adjustment range is $-3.5D$ to $+0.4D$. You can change the adjustment range by installing an exchange part. The adjustment range after the exchange is $-3.6D$ to $-0.8D$, or $-2.8D$ to $+2.0D$.

Contact a Sony service representative for more information about exchange parts.

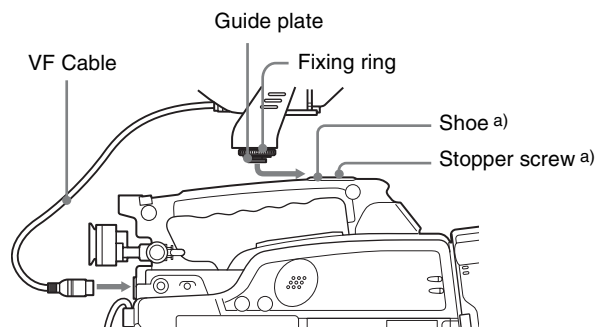

a) Supplied with the Accessory Shoe Kit

To adjust contrast and brightness

Carry out these adjustments with the color bars displayed.

- 1** Set the OUTPUT/DCC switch to the BARS position.
The color bars appear on the viewfinder screen.
- 2** Watching the color bars, turn the CONTRAST and BRIGHT controls to adjust the contrast and brightness.
- 3** Return the OUTPUT/DCC switch to its original position.

To adjust the outline emphasis

You can rotate the PEAKING control to adjust the peaking, H detail, and V detail of the image in the viewfinder. These adjustments strengthen the outlines of the image in the viewfinder, making it easier to focus the camera.

Menu settings allow you to adjust peaking only with the PEAKING control, and to adjust H detail and V detail separately.

For details, see “Setting the Viewfinder Screen Display” on page 137.

Attaching a 5-inch Electronic Viewfinder

You can attach an optional DXF-51 (5-inch) Electronic Viewfinder. To attach it, an Accessory Shoe Kit (service part number: A-8274-968-B) is required.

For details, contact your Sony dealer.

Remove the cover of the grip, and attach the shoe and stopper screw of the Accessory Shoe Kit.

Using the Shoulder Strap

- 1 Fit one of the clips to a shoulder strap fitting.

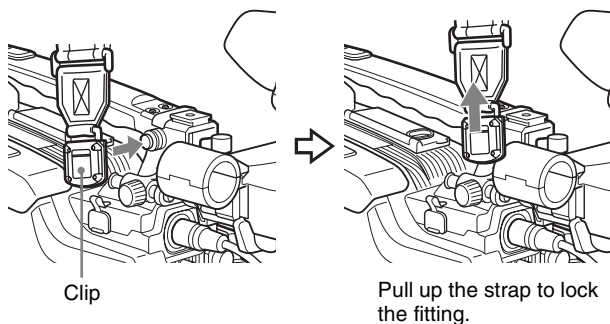

- 2 Fit the other clip to the shoulder strap fitting on the other side of the grip in the same way as in step 1.

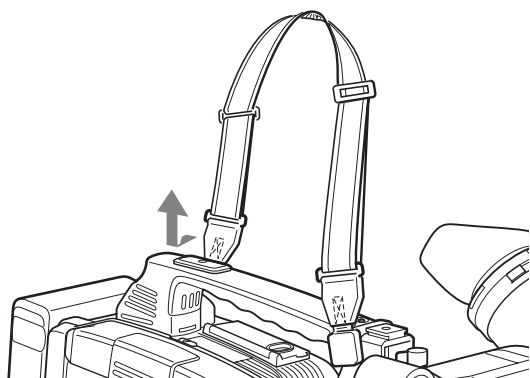

To remove the shoulder strap

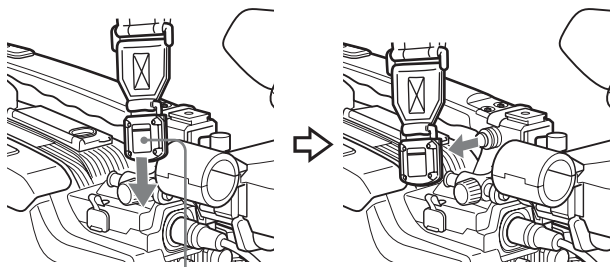

Pull in the direction of the arrow while pressing here.

Adjusting the Shoulder Pad Position

You can shift the shoulder pad backward or forward by up to 35 mm (1 ⁷/₁₆ inches). This adjustment helps you get the best balance for shooting with the camcorder on your shoulder.

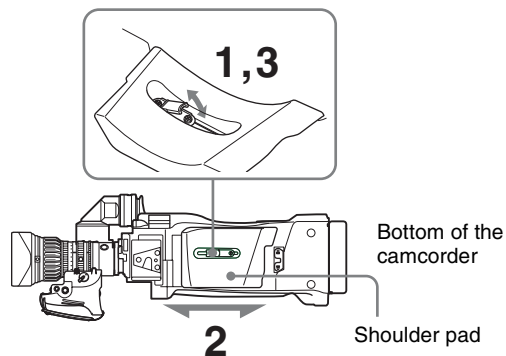

- 1 Raise the lever in the center of the shoulder pad to unlock the shoulder pad.
- 2 Slide the shoulder pad backward or forward until it is in the most convenient position.
- 3 Bring down the lever to lock the shoulder pad in the selected position.

Mounting on a Tripod

First fit the VCT-U14 Tripod Adaptor to the tripod, then mount the camcorder on the tripod adaptor.

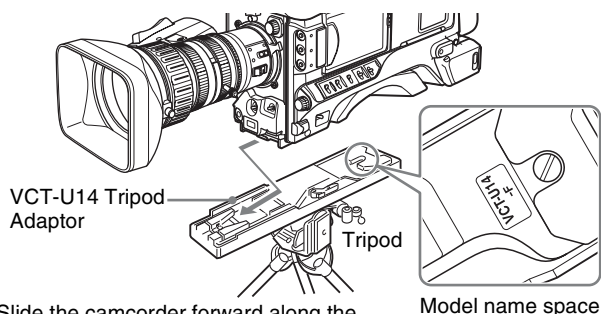

Slide the camcorder forward along the slot, until it clicks firmly into place.

Note

The camcorder cannot be mounted on a tripod adaptor with one of the following indications in the model name space, as shown in the above illustration. Use the appropriate tripod adaptor.

- “VCT-U14” only
- “VCT-U14-B”
- “VCT-U14-D”

To remove the tripod

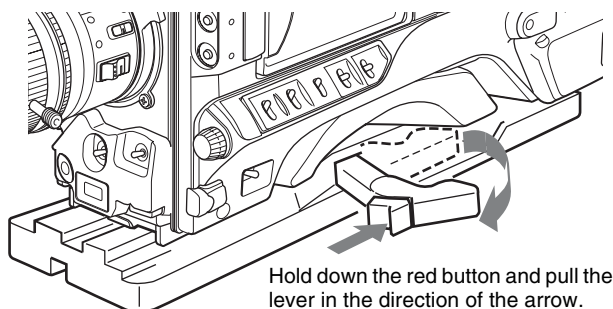

Hold down the red button and pull the lever in the direction of the arrow.

Note

After removing the camcorder, if the tripod adaptor pin has not returned to its original position, hold down the red button and move the lever in the direction of the arrow to return the pin to its original position. It is not possible to mount a camcorder with the pin left out.

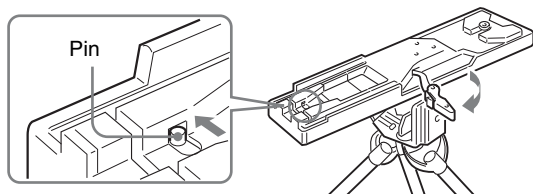

Using a Video Light

With this camcorder, you can use the Anton Bauer Ultralight 2 or equivalent video light (powered by 12 V with maximum power consumption of 50 W).

- If you connect the video light to the LIGHT connector on the camcorder and set the LIGHT switch to AUTO, you can turn the light on and off automatically as you start and stop the VDR operation.
- The output of the LIGHT connector on the camcorder is controlled to 12 V even when the camcorder is supplied with 12 V or more power (through the DC IN connector or battery pack). The brightness or color temperature of the light will not change according to voltage increase.

Notes

- Do not use a video light with power consumption of over 50 W.
- The brightness or color temperature of the light will change when the voltage (supplied through the DC IN connector or from the battery pack) is under 12 V.

To attach the video light

Fit the video light to the accessory fitting shoe on the camcorder grip, and connect the video light cable to the LIGHT connector.

Note

The accessory fitting shoe on this unit is of the 1/4-inch tapped hole type. If you want to replace this with a slide-type shoe, contact your Sony dealer.

Preparing the Audio Input System

Using the Supplied Microphone

- 1 Loosen the screw and open the microphone holder clamp.

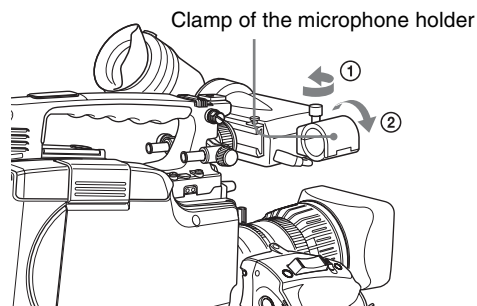

- 2 Place the microphone in the microphone holder.

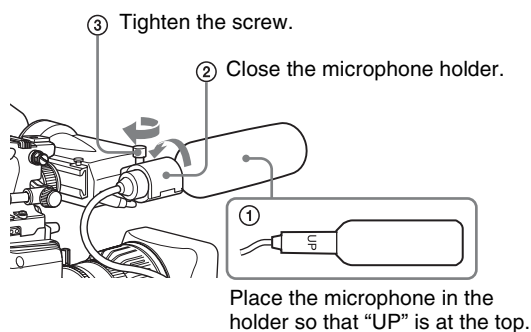

- 3 Plug the microphone cable into the MIC IN connector, then set the AUDIO IN switch for the channel on which you want to record the audio from this microphone to FRONT (for CH-1/CH-2) or F (for CH-3/CH-4).

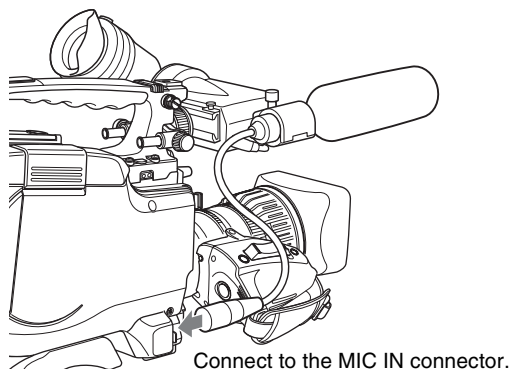

To use the microphone detached from the camcorder

You can use the supplied microphone detached from the camcorder.

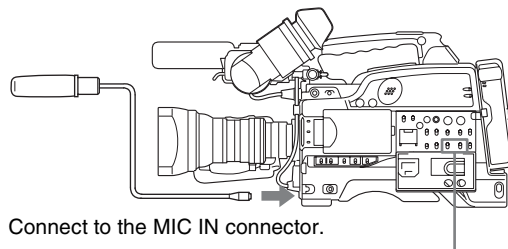

AUDIO IN (CH-1/CH-2) switches
Set the AUDIO IN switch for the channel on which you want to record the audio to FRONT (for CH-1/CH-2) or F (for CH-3/CH-4).

Note

When using the supplied microphone with an extension cable, always use an external power supply type cable.

Using an External Microphone

You can connect up to two external monaural microphones to the AUDIO IN CH-1/CH-2 connectors, using a CAC-12 Microphone Holder (not supplied).

The following is the procedure for attaching an electret condenser microphone such as the ECM-673/674/678.

- 1 Remove the fixing screws for external microphone holder.

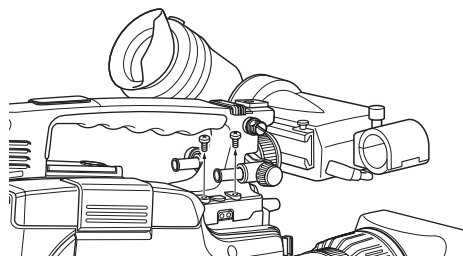

- 2 Attach the CAC-12 Microphone Holder.

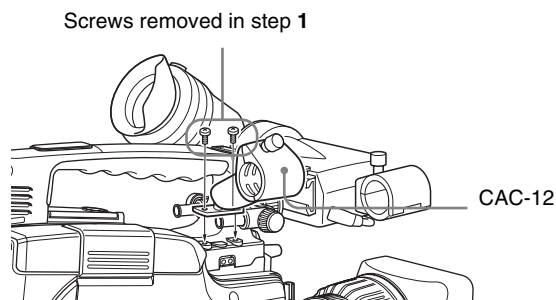

- 3** Open the CAC-12 and remove the microphone adaptor.

When attaching an ECM-673/674/678, use the microphone adaptor supplied with the ECM-673/674/678.

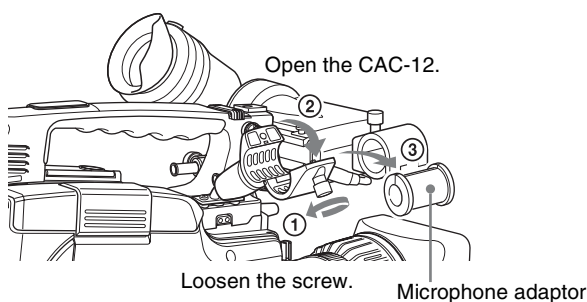

- 4** Place an external microphone (electret condenser microphone such as the ECM-673/674/678) in the CAC-12.

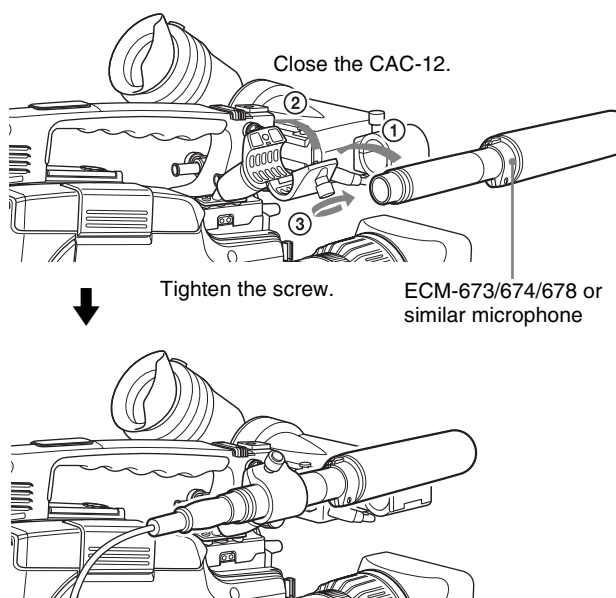

- 5** Connect the microphone cable to the AUDIO IN CH-1 or CH-2 connector.

- 6** Set the switches as follows.

- Set the AUDIO IN input selection switch as indicated below, depending on the type of microphone used.
 - **When using a microphone with an internal power supply**, set it to MIC (center).
 - **When using a microphone with an external power supply**, set it to MIC +48V ON (right).
- Set the AUDIO IN (CH-1/CH-2/CH-3/CH-4) switch for the channel to which the microphone is connected to REAR (for CH-1/CH-2) or R (for CH-3/CH-4).

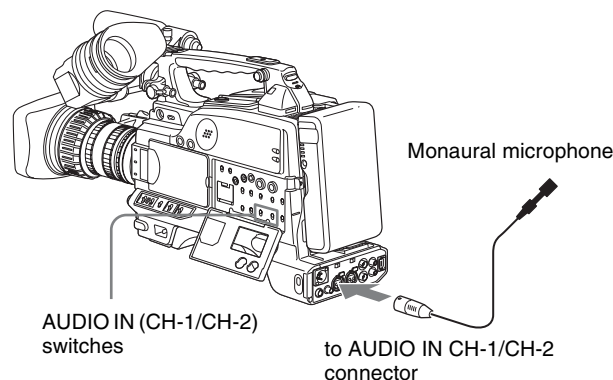

- 7** Switch the input level to match the sensitivity of the microphone used.

Switch the input level by changing the REAR MIC REF setting on the AUDIO-1 page of the MAINTENANCE menu (factory default setting is -60 dB).

For more details, see page 117.

Notes

- If the input level on this unit is not at an appropriate setting for the microphone sensitivity, loud sounds may be distorted, and the signal-to-noise ratio may be affected.
- In order for the AUDIO IN CH-1 and CH-2 connectors on the camcorder to be able to provide a phantom 48 V power supply, female XLR connectors (3-pin) are fitted. If the microphone cable has a female connector, use an adaptor.
- When you detach a CAC-12 Microphone Holder once you have attached to the camcorder, be careful not to lose the two screws fixing the CAC-12 (in step 1). After detaching the CAC-12, be sure to put the two screws back into their original places.

Attaching a UHF Synthesized Tuner

You can record sound by using a wireless microphone system consisting of the following.

- WRT-804/807S UHF Wireless Microphone
- WRT-822/824 UHF Synthesized Transmitter
- WRR-855/861/862 UHF Synthesized Tuner

Note

For the power source of this wireless microphone system, use Sony lithium-ion battery packs.

For details on using the wireless microphone system, see the operating instructions for the microphone and tuner.

To attach a WRR-855

- 1 Open the cover of the WRR connector.

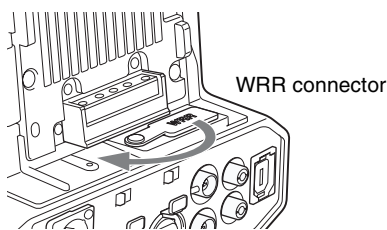

- 2 Set the power switch of the WRR-855 to ON, and set MUTING to ON or OFF.

This enables the WRR-855 power to be turned on and off with the camcorder POWER switch.

- 3 Insert the WRR-855 into the CA-WR855.

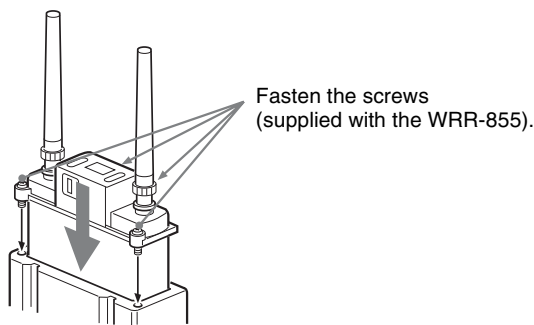

- 4 Engage the V-shaped plate on the back of the CA-WR855 with the V-groove on the battery attachment shoe, and then slide the CA-WR855 down until it connects to the WRR connector.

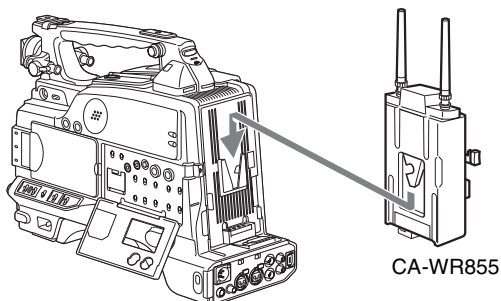

- 5 Set the AUDIO IN switch to WIRELESS (for CH-1/CH-2) or W (for CH-3/CH-4).

To attach a WRR-861/862 (When using a BP-GL95/GL65/L60S/L80S Battery Pack)

- 1 Attach a WRR tuner fitting (not supplied, service part number: A-8278-057-B) to the back of the camcorder.

- ① Use a Phillips type screwdriver to tighten the four screws placed in the tuner fitting as illustrated below.

Note

Check that the four screws are firmly tightened.

- ② Loosen the adjustment screws of the tuner fitting.
- ③ Adjust the tuner fitting position for a BP-GL95/GL65/L60S/L80S Battery Pack to be attached, and tighten the adjustment screws to fix its position.
- ④ Attach the mount plate supplied with the WRR-861/862.

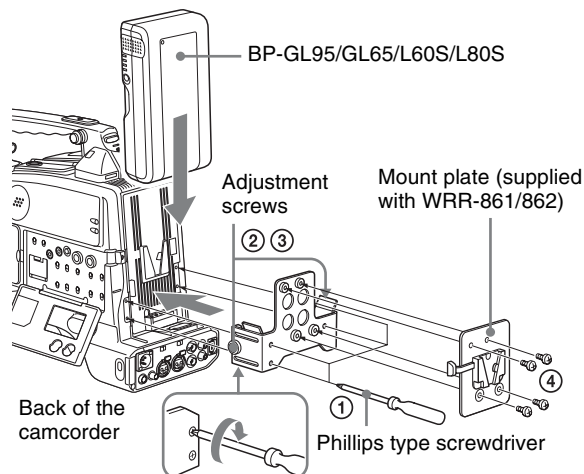

- 2 Attach the battery pack.

For details about attaching the battery pack, see "Using a Battery Pack" on page 31.

- 3 Mount the tuner on the WRR tuner fitting.

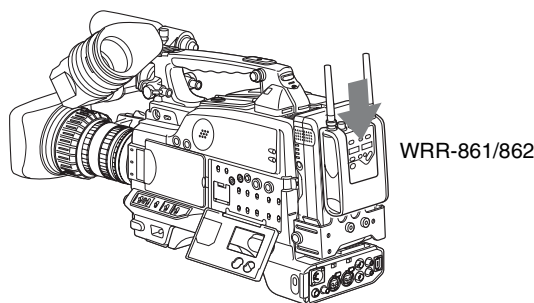

For details about the WRR tuner fitting (service part number: A-8278-057-B), contact your Sony dealer.

- 4 Connect the tuner power cord to the DC OUT connector of the camcorder, and the audio output cable to the AUDIO IN CH-1 or CH-2 connector.

- 5 Set the switches as follows.

- Set the AUDIO IN input selection switch to MIC for the channel to which the audio output cable is connected.
- Set the AUDIO IN (CH-1/CH-2/CH-3/CH-4) switch for the channel to which the audio output cable is connected to REAR (for CH-1/CH-2) or R (for CH-3/CH-4).

Connecting Line Input Audio Equipment

- 1 Connect an audio mixer or other external audio system component to the AUDIO IN CH-1/CH-2 connector as shown below.

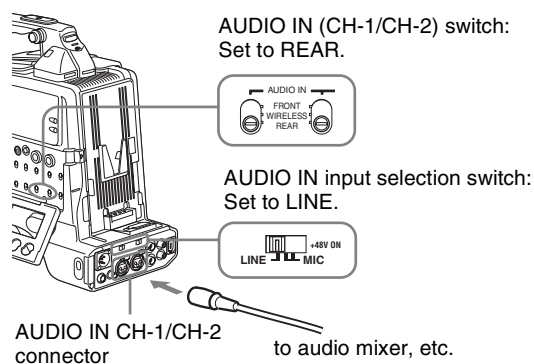

- 2 Set the AUDIO IN input selection switch to LINE for the channel to which the external audio equipment is connected.

Selection of the recording audio input

Set the AUDIO IN (CH-1/CH-2/CH-3/CH-4) switch for the channel to which the audio device is connected to REAR (for CH-1/CH-2) or R (for CH-3/CH-4).

Connecting the Remote Control Unit

Connecting the RM-B150/B750 Remote Control Unit enables remote control of the principal camera and VDR functions.

Connecting the remote control unit to the REMOTE connector (8-pin) automatically puts the camcorder into remote control mode. If you disconnect the remote control unit, the remote control mode is cancelled.

Refer to the RM-B150/B750 Operation Manual for the maximum cable length for connections between the camcorder and the RM-B150/B750.

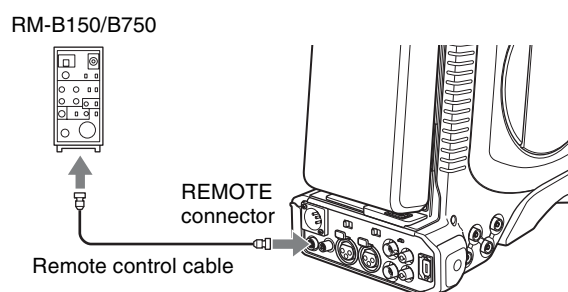

Note

Before connecting/disconnecting the remote control unit to/from the camcorder, be sure to turn off the camcorder POWER switch.

Camcorder switch functions when the remote control unit is connected

Connecting the remote control unit disables the following switches on the camcorder.

- GAIN switch
- OUTPUT/DCC switch
- WHITE BAL switch
- AUTO W/B BAL switch
- SHUTTER switch

Paint adjustment when the remote control unit is connected

The settings of the paint adjustment that were in effect the last time the remote control unit was used are recalled.

When the monitor is connected to the remote control unit

The MONITOR connector (BNC type) of the RM-B150/B750 outputs the same signal as that from the VIDEO OUT connector on the camcorder.

Use the black cable supplied with the RM-B150/B750 to connect the monitor to the MONITOR connector on the RM-B150/B750.

The camcorder does not have a function to output test signals.

Even when TEST is selected using the output signal selection switch (button) of the remote control unit, the test signal is not output from the MONITOR connector.

When the remote control unit is disconnected from the camcorder

The camcorder settings return to the settings in effect before the remote control unit was connected.

Structure of the paint adjustment data

The non-volatile memory of the camcorder used for storing paint adjustment data consists of two regions as shown below: one is the “independent data region” that is used when a remote control unit is not connected, and the other is the “remote control data region” that is used when a remote control unit is connected. Paint adjustment data is automatically selected and output to the camera section depending on whether or not a remote control unit such as the RM-B150 is connected.

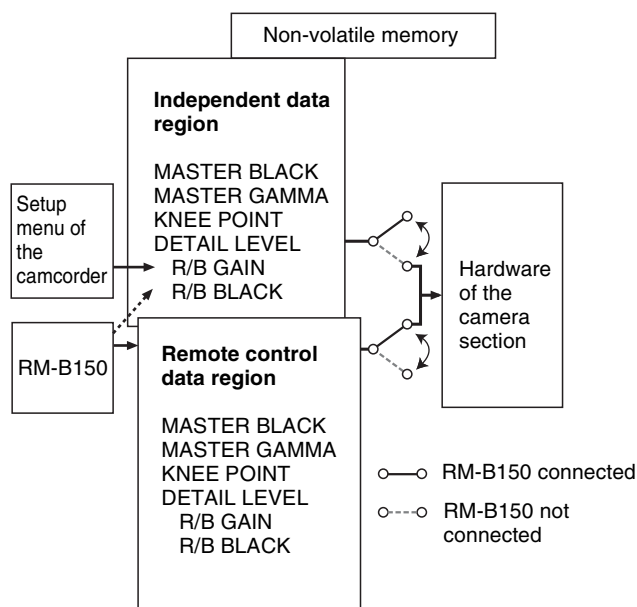

Thus, when a remote control unit is connected to the camcorder, the effective data region is switched to the “remote control data region” and the settings of the paint adjustment that were in effect the last time the remote control unit was used are recalled.

The settings of the absolute value rotational controls ¹⁾ and absolute value switches ²⁾ are overwritten by those on the remote control unit after the remote control unit is connected.

When the remote control unit is disconnected from the camcorder, the “independent data region” becomes

effective. Thus the camcorder will return to the settings that were in effect before the remote control unit was connected.

- 1) **Absolute value rotational controls:** The data corresponding to the angular position of controls is output. Rotational controls for which the data corresponding to the amount of their rotation is output are called relative value controls.
- 2) **Absolute value switches:** Like toggle switches or slide switches (except momentary switches), the switches (or knobs) whose positions must coincide with their functions are called absolute value switches.

Connecting

Note

Production of some of the peripherals and related devices described in this chapter has been discontinued. For advice about choosing devices, please contact your Sony dealer or a Sony sales representative.

Connecting an External Video Monitor

When using a Sony liquid crystal display monitor, make the connections as follows.

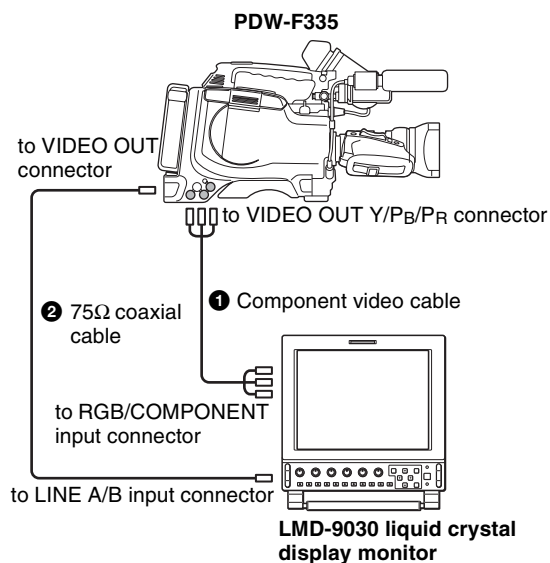

- 1 To check an analog HD/SD (NTSC/PAL) signal**
Connect the VIDEO OUT Y/Pb/Pr connectors of this unit and the RGB/COMPONENT input connectors of the LMD-9030 liquid crystal display monitor with a component video cable (not supplied).

The signal output from the VIDEO OUT Y/Pb/Pr connectors can be switched with COMPONENT OUT on the OUTPUT page of the OPERATION menu. For more details, see page 110.

Note

It is not possible to add text information or markers to the HDSDI output.

- 2 To check an SD (NTSC/PAL) signal**
Connect the VIDEO OUT connector of this unit and the LINE A or LINE B input connector of the LMD-9030

liquid crystal display monitor with a 75Ω coaxial cable (not supplied).

Using an i.LINK Connection

Using the **i** (i.LINK) DV OUT S400 connector, you can connect external equipment to the camcorder. Video recorded in the MPEG HD format is down-converted to the DVCAM format and output from the **i** (i.LINK) DV OUT S400 connector.

For connections using FAM (file access mode), see “File Operation” (page 155).

Settings required for an i.LINK connection

i.LINK MODE setting

Set the method of connection between this unit and an external device. On the OUTPUT page of the OPERATION menu, set i.LINK MODE to AV/C (Audio/Video Control). (The factory default setting is AV/C.) Make the i.LINK AUDIO OUT setting depending on the connected device.

i.LINK AUDIO OUT setting

Set the audio output channels for the **i** (i.LINK) DV OUT S400 connector. On the AUDIO-2 page of the MAINTENANCE menu, set i.LINK AUDIO OUT to one of the following. (The factory default setting is “2CH”.)
2CH: Output channels 1 and 2 (16 bits, 48 kbps)
4CH: Output channels 1 to 4 (12 bits, 32 kbps)

Note

When the scan mode is 23.98P, video, audio, or timecode output via the i.LINK connection may not be continuous.

Using the camcorder as a feeder

To copy digitally from the camcorder to the VTR without the editing function

Using an i.LINK cable (DV cable) to connect a digital video cassette recorder with an i.LINK connector to the camcorder, digital copy of video and audio can be carried out.

Example of connection

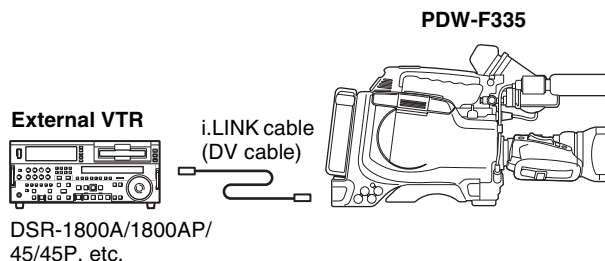

- 1 Make the following settings to prepare the external VTR.
 - Set REC MODE to the same recording mode as that of the camcorder.
 - When the recording mode is set to DVCAM, select either DF or NDF.
 - Set AUDIO MODE to either 4-channel or 2-channel mode, according to the disc that is played on the camcorder.
- 2 Pause recording on the external VTR.
- 3 Play the disc on the camcorder.
- 4 Check the playback on the camcorder, and when playback reaches the scene that you want to record, start recording again on the external VTR.

The copy to the external VTR starts.
- 5 When copy to the external VTR is finished, stop playback of the disc on the camcorder.

For details about external VTR operations, see the instruction manual supplied with the external VTR.

To control the camcorder from a VTR with editing function

By connecting a VTR with an i.LINK connector to the **i** (i.LINK) DV OUT S400 connector of the camcorder using an i.LINK cable (DV cable), you can control playback and recording on the camcorder and perform cut editing and digital copy.

Example of connection

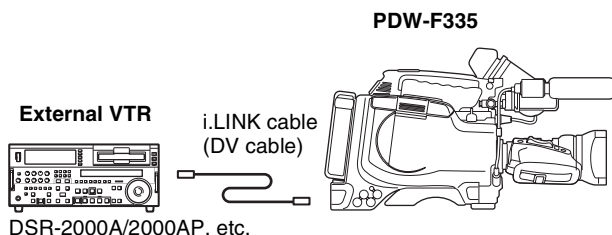

When using the DSR-2000A/2000AP, press the i.LINK button on the remote control setting section of the VTR.

Note

To use the automatic copying function of the DSR-2000A/2000AP, it is necessary to set the recording format of the camcorder to DVCAM on the FORMAT page of the OPERATION menu.

For details on the external VTR, see the instruction manual supplied with the external VTR.

To control the camcorder from a nonlinear editing system

Using the i.LINK cable (DV cable), you can transfer video and audio signals to a nonlinear editing system from the camcorder. Editing software that supports the selected recording format (DVCAM) must be used.

Example of connection

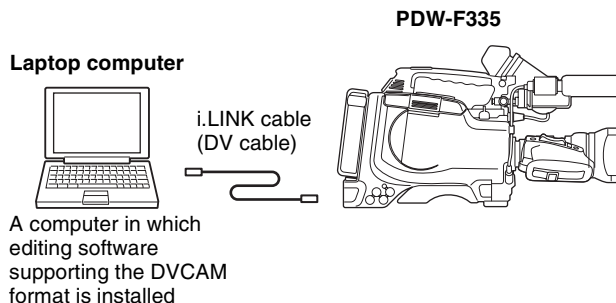

Operate the computer to set up the nonlinear editing software.

For details, see the software's manual.

Notes

- Video edited using a nonlinear editing system cannot be recorded to disc on this camcorder via an i.LINK cable (DV cable).
- When a disc with non-continuous timecode recorded is subjected to video capturing on a nonlinear editing system, the capturing precision may not be frame accurate.

Connections for Using the PDZ-1

To use the supplied PDZ-1 Proxy Browsing Software, connect the computer on which PDZ-1 is installed to this unit in FAM (file access mode).

For details of the connection, see "Making FAM Connections" on page 158.

For details of PDZ-1, see "Using the PDZ-1 Proxy Browsing Software" on page 97.

Handling Discs

Discs Used for Recording and Playback

This unit can record and play back the following Professional Disc ¹⁾ formats.

- PFD23 (capacity 23.3 GB)
- PFD23A (capacity 23.3 GB)
- PFD50DLA (capacity 50.0 GB)

1) Professional Disc is a trademark of Sony Corporation.

Notes

- It is not possible to use the following discs for recording or playback:
 - Blu-ray Disc
 - Professional Disc for Data
- PFD50DLA discs can be used only by XDCAM devices with the DL mark (*see the following illustration*). They cannot be used by XDCAM devices without this mark.



Notes on Handling

Handling

The Professional Disc is housed in a cartridge, and is designed to allow handling free of risk from dust or fingerprints. However, if the cartridge is subjected to a severe shock, for example by dropping it, this can result in damage or scratching of the disc. If the disc is scratched, it may be impossible to record video/audio, or to play back the content recorded on the disc. The discs should be handled and stored carefully.

- Do not touch the surface of the disc itself within the cartridge.
- Deliberately opening the shutter may cause damage.
- Do not disassemble the cartridge.
- The supplied adhesive labels are recommended for indexing discs. Apply the label in the correct position.

Storage

- Do not store discs where they may be subjected to direct sunlight, or in other places where the temperature or humidity is high.
- Do not leave cartridges where dust may be able to gain ingress.
- Store cartridges in their cases.

Care of the discs

- Remove dust and dirt on the outside of a cartridge using a soft dry cloth.
- If condensation forms, allow ample time to dry before use.

Write-Protecting Discs

To protect the content recorded on the disc from accidental erasure, move the Write Inhibit tab on the lower surface of the disc in the direction of the arrow, as shown in the following figure.

Lower surface of the disc Write Inhibit tab

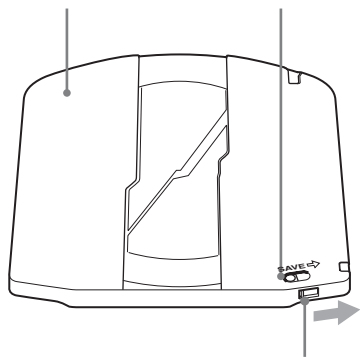

Slide in the direction of the arrow

Write Inhibit tab settings



Recording enabled



Recording disabled

You can also write protect individual clips. For details, see “Locking (Write-Protecting) Clips” (page 81).

Loading and Unloading a Disc

Loading a disc

Proceed as follows.

- 1 Turn on the POWER switch.

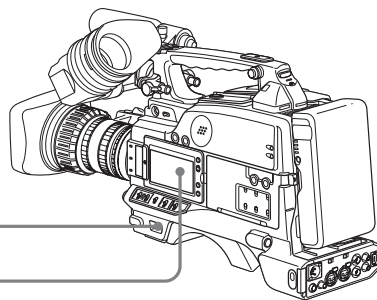

POWER switch

HUMID indicator

Note

If there is condensation inside the VDR section, the message “HUMID” appears in the status display on the LCD monitor. If this happens, wait until the indicator goes off before going on to step 2.

- 2 Press the EJECT button.

This opens the lid of the disc compartment.

EJECT button

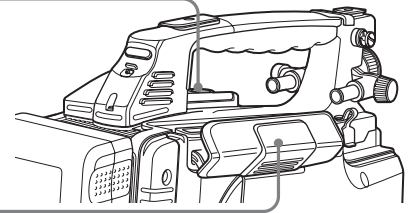

Lid of the disc compartment

- 3 Insert the disc in the ▼ direction, and close the disc compartment lid manually.

Insert the disc.

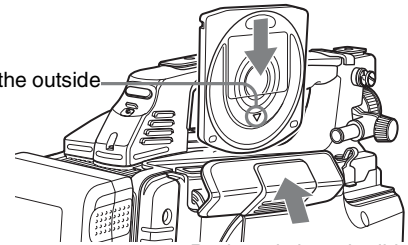

▼ indication on the outside

Push and close the lid.

The disc is loaded.

Note

To insert the disc correctly, make sure that the camcorder is in the upright position (the grip upside, the bottom downside).

Unloading a disc

With the power supply on, press the EJECT button to open the disc compartment lid and eject the disc, then remove the disc. If you are not going to insert another disc, close the disc compartment lid.

Formatting a Disc

Using a new disc

An unused disc requires no formatting operation. The disc is automatically formatted so that it is ready to use when loaded into this unit.

Using a disc on which material is recorded

To format a recorded disc, load the disc into the unit then do as follows.

Note

When a recorded disc is formatted, all the data on the disc is erased. (Locked clips (see page 81) are also erased.)

(How to select an item in the menu screen: Turn the MENU knob to move the ► mark to the desired item.)

- 1 Display the DISC page of the USER (or OPERATION) menu, and press the MENU knob.

For details of menu operations, see page 130.

```

004●DISC          TOP
→DELETE LAST CLIP: EXEC
DELETE ALL CLIPS: EXEC
QUICK FORMAT      : EXEC
  
```

- 2 Select QUICK FORMAT, and press the MENU knob.

The message “QUICK FORMAT OK? YES ► NO” appears.

- 3 To carry out the formatting, select YES, and press the MENU knob.
To cancel, press the MENU knob leaving NO selected.

When formatting is completed, the message “COMPLETED” appears.

Handling of Discs When Recording Does Not End Normally (Salvage Function)

Recording processing does not end normally if, for example, the battery pack is removed during recording, or if the power cord is disconnected during recording. Because the file system is not updated, video and audio data recorded in real time is not recognized as files and clip contents recorded up to that point are lost.

However, this unit has a salvage function which can hold losses to the minimum by reconstructing clips on such discs.

Note that no recorded clip contents are lost when the POWER switch is set to OFF and when battery exhaustion is detected, because the unit does not become powered off until after the end of recording processing.

Notes

- Do not disconnect the battery pack or power cord until recording processing has finished and the ACCESS indicator has gone out.
- This function salvages as much recorded material as possible after an unforeseen accident, but 100% restoration cannot be guaranteed.
- Even when this function is used, it is not possible to recover data from immediately before the interruption of recording. The amount of data lost is as follows.

Quick salvage: From 2 to 4 seconds of data before the interruption of recording.

Full salvage: From 4 to 6 seconds of data before the interruption of recording.

(More data may be lost when the unit is subject to vibrations, when you switch frequently between recording and paused, and when you use functions such as Interval Rec.)

Quick salvage

When the unit is powered on again after a recording interruption due to a power interruption, with the disc still loaded in the unit, clips are reconstructed on the basis of backup data stored in nonvolatile memory and markers recorded on the disc. Processing time is about 5 seconds.

Full salvage

When recording on an XDCAM device is interrupted because of a power interruption, and a disc is manually ejected from that device with the power off, clips are reconstructed on the basis of markers recorded on the disc when the disc is loaded in this unit. Therefore, processing takes longer than for a quick salvage (about 30 seconds, although it depends on the state of the disc).

Note

Before using another XDCAM device ¹⁾ to perform a full salvage of a disc that was recorded successfully on the PDW-F75/F355/F335, check that the version of the other device is version 1.7 or higher. Salvage cannot be completed successfully on version 1.6 or lower devices.

1) PDW-F350/F330, PDW-530/510, PDW-F70/F30, PDW-1500, PDW-R1, PDW-V1, PDW-D1, and PDW-70MD

Proceed as follows to perform a full salvage.

- 1 Insert the disc on which recording did not end normally.

The following salvage message appears.

```

SALVAGE
TO RECORD ON THE
DISC, IT IS NECESSARY
TO EXECUTE SALVAGE.

SALVAGE OK?
YES → NO
  
```

- 2 Select YES, and press the MENU knob.

Salvage processing starts, and the message “EXECUTING.” appears.

A results message appears when the processing finishes.

- If the salvage succeeded, the message “COMPLETED.” appears.
- If the salvage failed, the message “INCOMPLETED.” appears. Clips for which recording did not end normally are lost.

To exit without salvaging

Select NO in step 2 to exit without performing salvage processing.

However, the status of the disc does not change.

Salvage is still required to recover the clips for which recording did not end normally. The salvage message will appear again when that disc is inserted again, or when the camcorder is powered on again.

Note

If salvage processing is not done, sections which were recorded normally can be played back, but no new recording can be done on the disc.

Basic Procedure for Shooting

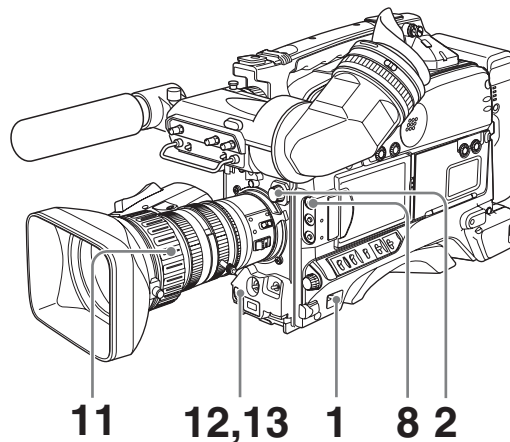

- 1 Set the POWER switch to ON.
- 2 Set the FILTER selector and the 5600K button appropriately for the lighting conditions.

| FILTER selector setting | Examples of shooting conditions |
|-------------------------|---|
| 1 (CLEAR) | Indoor shooting |
| 2 ($1/4$ ND) | Cloudy or rainy outdoor shooting, or to reduce the depth of field ^{a)} |
| 3 ($1/16$ ND) | Sunlight |
| 4 ($1/64$ ND) | To reduce the depth of field in sunlight |

a) The range over which the subject is sharply in focus. Thus, “reducing the depth of field” means that the range is reduced as well, and “increasing the depth of field” means that it is increasing as well.

- 3 Check the switch settings on the camcorder.

If you do not have enough time to check the settings of the unit, you can turn the EZ MODE-assigned switch on to use EZ mode for instant shooting.

EZ mode

In EZ mode, the settings of this unit are fixed at standard values, and the lens aperture and white balance are adjusted automatically. In this state, it is not possible to change menu or other settings. To change settings, turn EZ mode off. In the factory default configuration, the ASSIGN 1 switch (see page 13) turns EZ mode on and off.

- 4 Check the settings in the menu.

- 5 Check the lens settings and flange focal length adjustment (*see page 35*).
- 6 Adjust the viewfinder eyepiece focus, and the contrast and brightness of the viewfinder image (*see page 37*).
- 7 Check the audio system settings.
 - Microphone connections (*see page 41*)
 - Settings on the VDR section (*see page 19*)
- 8 If necessary, display the center marker and/or safety zone marker on the viewfinder screen.

For details, see “Setting the Marker Display” on page 136.

Also, press the ZEBRA button to display a zebra pattern on the viewfinder screen.

- 9 If necessary, adjust the white balance and black balance (*see page 54*).

- 10 If necessary, adjust the iris and gain.

For details about the adjustment of iris, see “Iris ring” on page 25, and “Adjusting the Iris” on page 59.

For details about the adjustment of gain, see “GAIN switch” on page 14, and “Setting Gain Values for the GAIN Switch Positions” on page 140.

- 11 Turn the focus ring so that the subject is sharply in focus.

The EZ focus function allows you to set the aperture function to open, and to easily and precisely adjust the focus before shooting.

Before use, this function must be assigned to the ASSIGN 1 or 2 switch.

For details, see “Assigning Functions to ASSIGN Switches” (page 143).

About the EZ focus function

When you press the switch to which this function is assigned (the ASSIGN 1 or 2 switch), the function is turned on and “EZ FOCUS” appears in the viewfinder screen and the LCD monitor. To turn the function off, press the switch again. Even if you do not press the switch, the function goes off automatically after 10 seconds.

Note

The EZ focus function goes off automatically if it is on when you press the REC button on this unit or the lens. Recording starts immediately thereafter.

- 12 Set up the VDR section according to your shooting objects, then start recording by pressing the REC button.

- During recording, the REC/TALLY indicator in the viewfinder lights, and “REC” appears on the viewfinder screen.
- You can use the AUDIO LEVEL knob on the front of the camcorder to manually adjust the channel 1 audio level. To do this, you must first set up the VDR section to enable manual adjustment of the audio recording level (*see page 60*).

- 13 To pause recording, press the REC button again.

The REC/TALLY indicator in the viewfinder goes off. The material recorded from step 12 to step 13 is saved as a single clip.

To play back the recorded clip

Press the PREV button, then press the PLAY/PAUSE button to play from the beginning of the clip.

- 14 Repeat steps 12 and 13 as required to continue shooting.

Successive clips are recorded on the disc.

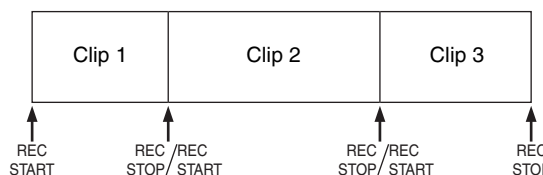

Notes

- It is not possible to record a clip shorter than 2 seconds. If you stop recording within 2 seconds of starting, this results in a 2-second clip. If you stop recording and restart within 2 seconds of the original start, this creates a single continuous clip from the original start time.
- The maximum number of clips that can be recorded on a single disc is 300. If an attempt is made to record more than 300 clips, the error message “MAX # Clips” appears, even if there is free capacity on the disc.

Recording – Basic Operations

Selecting the Recording Format

Before recording, select the recording format.

Note

There are restrictions on the recording formats that can be combined on a single disc.

(How to select an item in the menu screen: Turn the MENU knob to move the ► mark to the desired item.)

- 1 Display the FORMAT page of the USER (or OPERATION) menu, and press the MENU knob.

For details of menu operations, see “Basic Menu Operations” on page 130.

| | |
|-------------------|-----------------|
| 001●FORMAT | TOP |
| SYSTEM | 60I |
| REC FORMAT | : MPEG HD |
| BIT RATE (HD) | : 4ch |
| AUDIO CH (HD) | : 16:9 |
| ASPECT RATIO (DV) | : NTSC (J) AREA |
| COUNTRY | |

| Item | Description | Settings |
|---------------|---|--|
| SYSTEM | Frame frequency | NTSC: 60I/30P/23.9P PAL: 50I/25P |
| REC FORMAT | Recording format | MPEG HD/DVCAM |
| BIT RATE (HD) | Bit rate for HD recording | HQ/SP/LP (For details, see the following table titled “HD recording bit rate settings and recording times”.) |
| AUDIO CH (HD) | Number of audio channels for HD recording | 2ch/4ch |
| ASPECT RATIO | Aspect ratio for DVCAM recording | 16:9/4:3 |
| COUNTRY | Region of use | NTSC/PAL |

- 2 Select the desired item, and press the MENU knob.
- 3 Turn the MENU knob to select the desired setting, and press the MENU knob.

- 4 If you have changed the setting of SYSTEM or COUNTRY, power off the unit, then power on again.

- 5 Repeat steps 2 to 4 to set the all of the desired items.

HD recording bit rate settings and recording times

When PFD23/PFD23A discs are used:

| Bit rate | Audio channels used | Recording time |
|---|---------------------|---------------------|
| HQ mode ^{a)} Variable bit rate, upper limit 35 Mbps | 4 channels | 65 minutes or more |
| | 2 channels | 68 minutes or more |
| SP mode Fixed bit rate, 25 Mbps | 4 channels | Approx. 85 minutes |
| | 2 channels | Approx. 90 minutes |
| LP mode ^{a)} Variable bit rate, upper limit 18 Mbps | 4 channels | 112 minutes or more |
| | 2 channels | 122 minutes or more |

When PFD50DLA discs are used:

| Bit rate | Audio channels used | Recording time |
|---|---------------------|---------------------|
| HQ mode ^{a)} Variable bit rate, upper limit 35 Mbps | 4 channels | 145 minutes or more |
| | 2 channels | 150 minutes or more |
| SP mode Fixed bit rate, 25 Mbps | 4 channels | Approx. 190 minutes |
| | 2 channels | Approx. 200 minutes |
| LP mode ^{a)} Variable bit rate, upper limit 18 Mbps | 4 channels | 248 minutes or more |
| | 2 channels | 265 minutes or more |

a) In HQ mode or LP mode, as a result of MPEG2 compression, the recording time varies depending on the volume of the generated compressed image data, with the above figures as a minimum. For example, in material with little movement, the recording time may be significantly longer than shown above.

Note about recording times

An average of 1 second (up to a maximum of 2 seconds) of additional information is recorded whenever Clip Continuous Rec recording starts. The recording times listed above will be shorter if Clip Continuous Rec recording is done repeatedly.

Note

The recording and playback times listed above are approximate. Maximum recording times may vary depending on recording conditions.

Combining recording formats on a single disc

If any of the following items is set differently, recordings cannot be combined on a single disc.

- SYSTEM (although it is possible to mix 30P and 60I, and 25P and 50I)
- REC FORMAT
- AUDIO CH
- COUNTRY

Adjusting the Black Balance/White Balance

To ensure excellent image quality when using this camcorder, conditions may require that both the black balance and the white balance be adjusted.

If the black balance or white balance adjustment is started, messages that report on the progress and results are displayed on the viewfinder screen.

Note

Black balance and white balance adjustment values that are automatically set by the camcorder and the various settings are stored in the camcorder memory and retained even when the power is turned off.

To adjust the black balance

The black balance will require adjustment in the following cases.

- When the camcorder is used for the first time
- When the camcorder has not been used for a long time
- When the camcorder is used under conditions in which the surrounding temperature has changed greatly
- When the GAIN switch (L/M/H) values have been changed on the GAIN SW page of the OPERATION menu

It is not usually necessary to adjust the black balance when using the camcorder after it has been off.

In automatic black balance mode, adjustments are performed in the following order: clamp level, black set, and black balance.

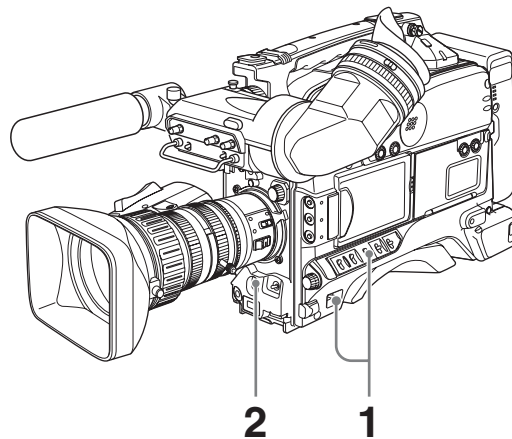

- 1 Power the camcorder on, and set the OUTPUT/DCC switch to CAM.
- 2 Push the AUTO W/B BAL switch to BLK and release the switch.

The switch returns to the center position, and the adjustment is executed. During adjustment, the following message is displayed on the viewfinder screen.

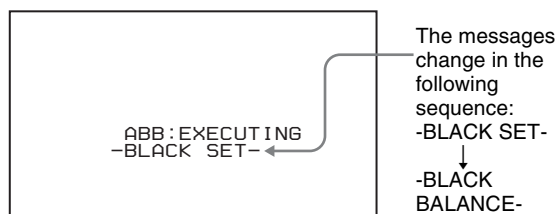

The black balance adjustment ends in a few seconds with the message “ABB: OK” and the adjustment value is automatically stored in memory.

Notes

- During the black balance adjustment, the iris is automatically closed.
- During the black balance adjustment, the gain selection circuit is automatically activated so you may see flickering on the viewfinder screen, but this is not a malfunction.

If automatic black balance adjustment cannot be made

If the black balance adjustment cannot be completed normally, an error message will appear for about 3 seconds on the viewfinder screen.

| Error message | Meaning |
|----------------------------|---|
| ABB: NG IRIS NOT CLOSED | The lens iris did not close. Check if the lens cable is connected properly. |
| ABB: NG TIME LIMIT | Adjustment could not be completed within the standard number of attempts. |

| Error message | Meaning |
|---------------------------------------|---|
| ABB: NG R (or G or B): OVERFLOW | The difference between the reference value and the current value is so great that it exceeds the range. |

If any of the above error messages is displayed, retry the black balance adjustment. Keep pushing the WHT/BLK switch to BLK until “-BLACK SET-” appears after “-BLACK BALANCE-” appears. If the error message occurs repeatedly, contact your Sony dealer.

To adjust the white balance

It is necessary to adjust the white balance each time the principal lighting source changes.

Note

When this unit is operating in EZ mode, the ATW function (see page 56) is forced to ON.

- 1 Set the switches and selectors as shown in the figure below.

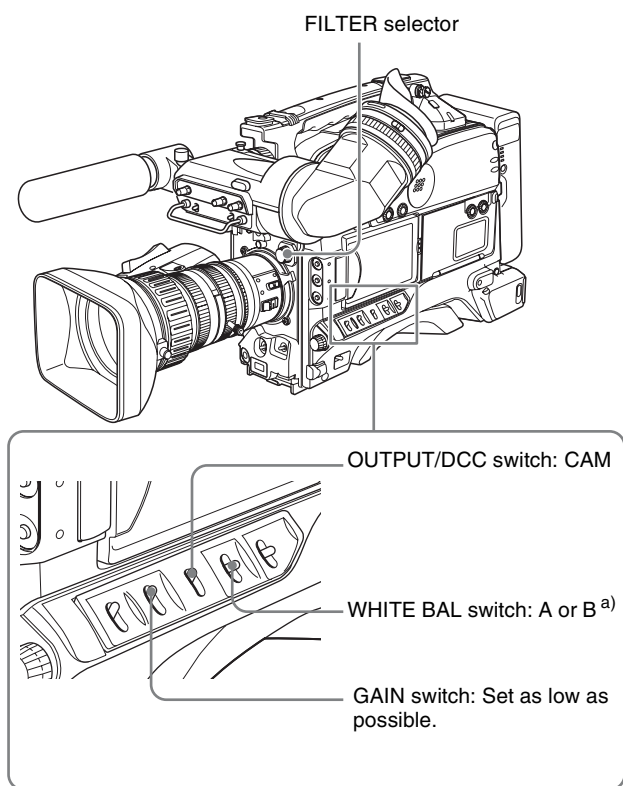

a) White balance setting values are stored in memory B only when the WHITE SWITCH item is set to MEM on the WHITE SETTING page of the MAINTENANCE menu.

- 2 Set the FILTER selector and the 5600K button to suit the lighting conditions.

The following table shows which FILTER selector setting you should use depending on the lighting conditions.

| FILTER selector setting | Lighting conditions |
|-------------------------|---|
| 1 (CLEAR) | Indoor shooting |
| 2 (1/4 ND) | Cloudy or rainy outdoor shooting, or to reduce the depth of field |
| 3 (1/16 ND) | Sunlight |
| 4 (1/64 ND) | To reduce the depth of field in sunlight |

If the setting of the FILTER selector is changed, a message reporting the new setting appears for about 3 seconds in the setting change and adjustment progress message display area of the viewfinder screen.

- 3 Place a white test card under the same lighting conditions as for the subject to be shot and zoom up to it.

Alternatively, any white object such as a cloth or a wall can be used.

The absolute minimum white area is as follows.

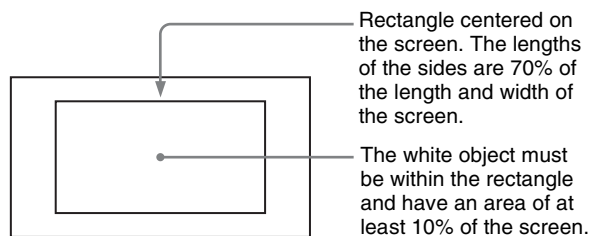

Note

Make sure there are not bright spots in the rectangle.

- 4 Adjust the lens iris.

Manually adjusted lens: Set the iris to an appropriate setting.

Lens with automatic iris: Set the automatic/manual switch on the lens to automatic.

- 5 Push the AUTO W/B BAL switch to WHT, and then release the switch.

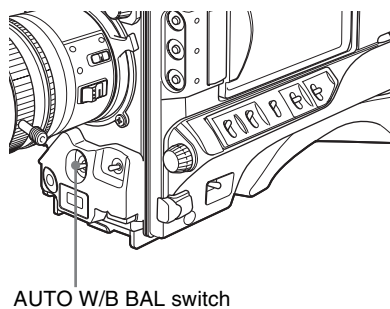

The switch returns to the center position, and the adjustment is executed.

During adjustment, the message “AWB: EXECUTING” is displayed on the viewfinder screen.

The white balance is adjusted in about one second, and the message “AWB: OK” appears. The adjustment setting is automatically stored in the memory (A or B) that was selected in step 1.

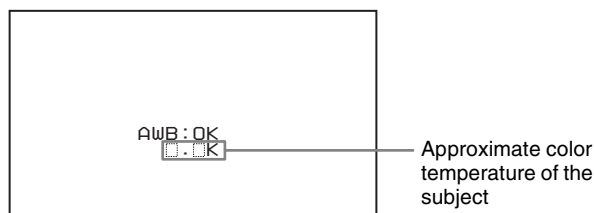

Notes

- The color temperature display that appears after white balance adjustment is calculated on the basis of the R/G/B signal output from the camera. It may not agree with the results of measurement by commercially available color temperature meters. The camcorder’s color temperature display should be regarded as an approximation.
- If the camera has a zoom lens with an automatic iris, the iris may hunt¹⁾. To prevent this, adjust the iris gain knob (indicated as IG, IS, or S) on the lens.

For details, refer to the lens operation manual.

1) **Hunting:** Repeated brightening and darkening of the image, resulting from repeated response to automatic iris control.

If the automatic white balance adjustment cannot be made

If the white balance adjustment cannot be completed normally, an error message will appear for about 3 seconds on the viewfinder screen.

| Error message | Meaning |
|-------------------------------|---|
| AWB: NG LOW LEVEL | The white video level is too low. Either open the lens iris or increase the gain. |
| AWB: NG COLOR TEMP HIGH | The color temperature is too high. |
| AWB: NG COLOR TEMP LOW | The color temperature is too low. |
| AWB: NG TIME LIMIT | Adjustment could not be completed within the standard number of attempts. Try to adjust again. If adjustment fails a few times, contact your Sony dealer. |
| AWB: NG POOR WHITE AREA | The white area could not be checked. |
| AWB: NG OVER LEVEL | The white video level is too high. Either stop down the lens iris or change the ND filter. |

If any of the above error messages is displayed, retry the white balance adjustment. If the error message occurs repeatedly, contact your Sony dealer.

If you have no time to adjust the white balance

Set the WHITE BAL switch to PRST.

The white balance is automatically set as follows, depending on the state of the 5600K button.

- 5600K button lit: 5600K
- 5600K button not lit: 3200K

About the white balance memory

Values stored in memory are held until the white balance is next adjusted.

There are two sets of white balance memories, A and B, which you can switch between with the WHITE BAL switch (PRST/A/B).

On the WHITE SETTING page of the MAINTENANCE menu, when WHT FILTER INH is set to OFF, there are two memories, A and B for each position of the ND filter of this unit (CLEAR, $\frac{1}{4}$ ND, $\frac{1}{16}$ ND, and $\frac{1}{64}$ ND). In this case, the memory is switched as you change the ND filter position, for a total of eight (4×2) memories.

If a memory error occurs

If the error message “: STORED DATA: NG” flashes on the viewfinder screen when the camcorder is turned on, the white balance memory contents have been lost. Adjust the white balance again. Contact your Sony dealer if this message continues to appear even after the white balance has been adjusted again.

Using the ATW (auto tracking white balance) function

By using the ATW function, the white balance is adjusted automatically when the lighting conditions change.

Note

Depending on the shooting conditions, the white balance may not always be correctly adjusted automatically. To get a precise white balance, it is recommended to use the WHITE BAL switch.

Turning the ATW function on using the WHITE BAL switch

- 1 On the WHITE SETTING page of the MAINTENANCE menu, set WHITE SWITCH to ATW.
- 2 Set the WHITE BAL switch to the B(ATW) position.

This turns the ATW function on, and the white balance is now adjusted automatically to respond to changes in the lighting conditions.

Turning the ATW function on using an ASSIGN switch

- 1 On the ASSIGNABLE page of the USER (or OPERATION) menu (see page 143), set one of ASSIGN 1 to ASSIGN 4 to ATW.
- 2 Press the ATW-assigned switch.

This turns the ATW function on, and the white balance is now adjusted automatically to respond to changes in the lighting conditions.

Setting the Electronic Shutter

This section describes the shutter modes that can be used with the electronic shutter of the camcorder, and describes the procedure for selecting the shutter speed and shutter mode.

About the shutter modes

The shutter modes that can be used with the electronic shutter and the shutter speeds that can be selected are listed below.

| Shutter mode | Frame frequency | Shutter speed | Application |
|---------------------------|-----------------|---|--|
| Standard | 60i | 1/100, 1/125, 1/250, 1/500, 1/1000, 1/2000 (sec.) | For shooting fast-moving subjects with little blurring. |
| | 30P | 1/40, 1/60, 1/120, 1/125, 1/250, 1/500, 1/1000, 1/2000 (sec.) | |
| | 23.98P | 1/32, 1/48, 1/96, 1/125, 1/250, 1/500, 1/1000, 1/2000 (sec.) | |
| | 50i | 1/60, 1/125, 1/250, 1/500, 1/1000, 1/2000 (sec.) | |
| | 25P | 1/33, 1/50, 1/100, 1/125, 1/250, 1/500, 1/1000, 1/2000 (sec.) | |
| ECS (Extended Clear Scan) | 60i | 60.0Hz to 19000Hz | For obtaining images with no horizontal bands of noise when shooting subjects such as monitor screens. |
| | 30P | 30.0Hz to 26000Hz | |
| | 23.98P | 24.0Hz to 21000Hz | |
| | 50i | 50.0Hz to 29000Hz | |
| | 25P | 25.0Hz to 25000Hz | |

| Shutter mode | Frame frequency | Shutter speed | Application |
|--------------------------|-----------------|---|---|
| SLS (Slow Speed Shutter) | | 2 to 8, 16, 32, 64 frames (1/15 to 1/3.8, 1/1.9, 1.1, 2.1 (sec.)) | For shooting subjects in low level lighting conditions. |

Notes

- Whatever the operating mode of the electronic shutter, the sensitivity of the CCD decreases with increasing shutter speed.
- When the automatic iris is used, the iris opens wider as the shutter speed increases, thus reducing the depth of field.
- Under artificial light, particularly fluorescent or mercury lamps, the light intensity may appear to be constant, but the red, green, and blue intensities are actually changing in synchronization with the frequency of the power supply causing flicker. Using an electronic shutter under such lighting could make the flicker even worse. Color flicker is particularly likely to happen when the power supply frequency is 60 Hz. However, if the power frequency is 50 Hz, setting the shutter speed to 1/100 can reduce this flicker.
- When a bright object is shot in ECS mode in such a manner that it fills the screen, the upper edge of the picture may have poor quality because of an inherent characteristic of CCDs. Before using ECS mode, check the shooting conditions.
- In SLS mode, CCD white dot noise becomes more prominent as the number of frames increases.

For details, see "Phenomena Specific to CCD Image Sensors" on page 164.

To select the shutter mode and shutter speed

Use the SHUTTER switch to select a shutter mode or a standard-mode shutter speed. To set the shutter speed in ECS or SLS mode, with the SHUTTER switch set to ON and the ECS or SLS mode selected, use the MENU knob for adjustment.

To set the shutter mode and the standard-mode shutter speed

Once the shutter speed is selected, it is retained even when the camcorder is turned off.

- 1 Make sure that neither menu nor status display is shown.
- 2 Push the SHUTTER switch from ON to SEL.

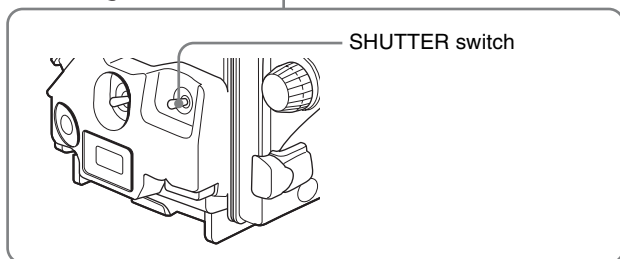
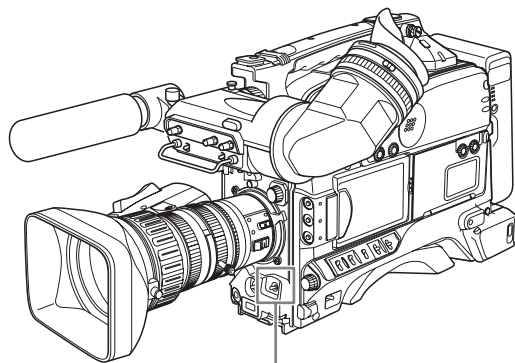

The current shutter setting indication appears for about 3 seconds in the setting change and adjustment progress message display area of the viewfinder screen.

Examples: “: SHUTTER: 1/250”, “: ECS: 60.0 Hz”, “: SLS: 1/15: 2FRAME”

- 3** Before the shutter setting indication in step **2** disappears, push the SHUTTER switch to SEL again.

Repeat this until the desired mode or speed appears.

The shutter speed display changes as in the following diagram.

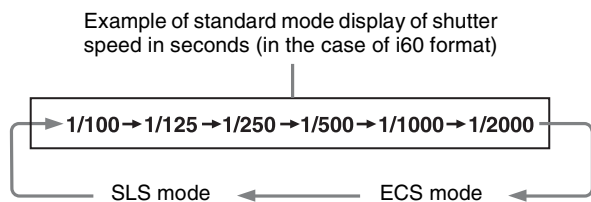

To set the shutter speed in ECS mode

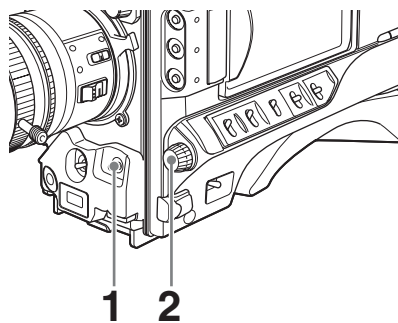

- 1** Carry out the steps in “To set the shutter mode and the standard-mode shutter speed” on page 57 to set the shutter mode to ECS.

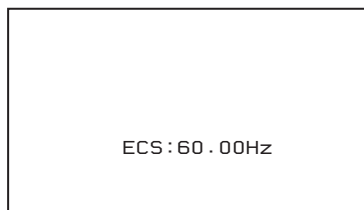

- 2** Turn the MENU knob until the desired frequency appears.

The selectable frequency range varies depending on the recording format. See the table under “About the shutter modes” on page 57.

When the RM-B150 Remote Control Unit is connected

You can set the shutter speed in ECS mode with the rotary encoder of the RM-B150.

To set the shutter speed in SLS mode

Notes

- When EZ mode is selected, SLS mode is forcibly deselected.
- When you start recording under the following conditions with the camcorder in SLS mode, a certain number of black frames are recorded at the top of the recorded clip. The number of black frames depends on the SLS setting.
 - During disc playback
 - During thumbnail display (page 76)

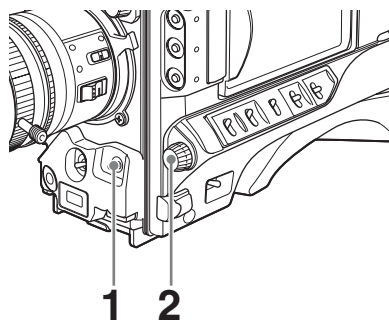

- 1** Carry out the steps in “To set the shutter mode and the standard-mode shutter speed” on page 57 to set the shutter mode to SLS.

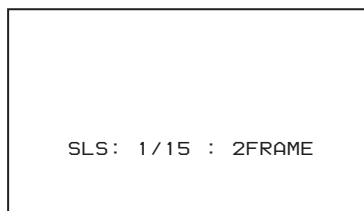

- 2** Turn the MENU knob until the desired number of frames appears.

The number of frames can be set to values in the range 2 to 8, 16, 32, and 64 (1 frame nearly equals to $1/30$ second).

To set the shutter speed in degree units

1 On the SHUTTER SELECT page of the MAINTENANCE menu, set SHUTTER SELECT to DEGREE.

SECOND: Set the shutter in second units.

DEGREE: Set the shutter in degree units.

The screen shown below appears. This screen allows you to set the shutter speed to one of six settings.

Default screen in 23.98PsF mode

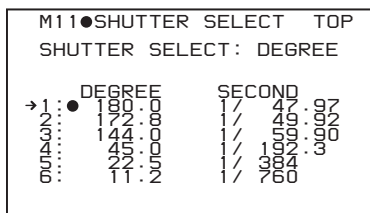

2 Set the shutter speed by pushing the SHUTTER switch to the SEL side, or by pressing and rotating the MENU knob.

Settings change in the following order when you push the SHUTTER switch to the SEL side.



Adjusting the Iris

Turning the auto iris function on and off

When the lens IRIS switch is in the A position, the auto iris function is on; when in the M position the function is off.

Note

When this unit is operating in EZ mode, the auto iris is forced ON.

To set the automatic iris

The reference value for automatic iris adjustment can be changed to aid the shooting of clear pictures of back-lit subjects, or to prevent blown-out highlights.

To change the reference value

(How to select an item in the menu screen: Turn the MENU knob to move the ► mark to the desired item.)

1 Display the PAINT page of the PAINT menu, and press the MENU knob.

For details on menu operations, see “Basic Menu Operations” on page 130.

2 Select A.IRIS, and press the MENU knob.

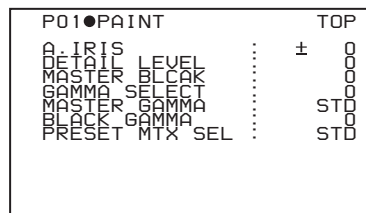

3 Turn the MENU knob to select the reference value from the following, and press the MENU knob.

- +0.5: about 0.5 stop further open
- +1.0: about 1 stop further open
- ±0: standard value
- -0.5: about 0.5 stop further closed
- -1.0: about 1 stop further closed

The changed reference value is retained until the power of the camcorder is turned off. Even if the reference value is changed, it reverts to the standard value every time the power is turned on. If the reference value is set to other than the ±0 value, the following indications appear on the viewfinder screen.

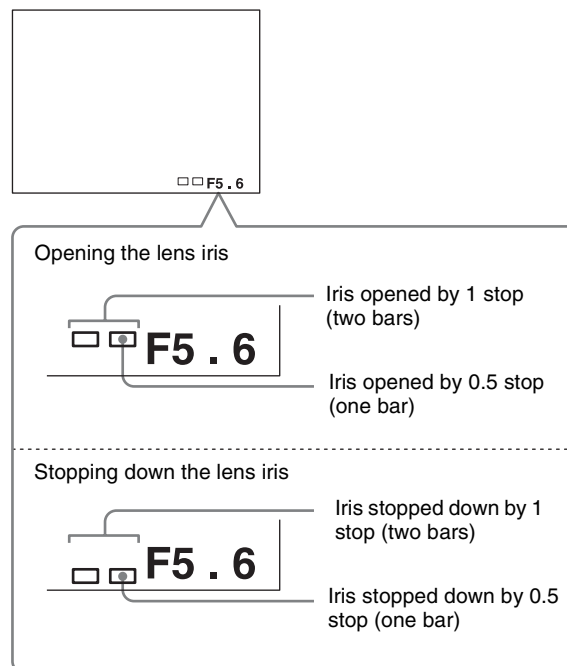

If you want to change the reference value during shooting

You can change the reference value by MENU knob operations only, without opening the menu.

Proceed as follows.

(How to select an item in the menu screen: Turn the MENU knob to move the ➔ mark to the desired item.)

- 1 Display the CAM CONFIG page of the MAINTENANCE menu (see page 120), and press the MENU knob.

For details on menu operations, see “Basic Menu Operations” on page 130.

- 2 Select IRIS OVERRIDE, and press the MENU knob.
- 3 Turn the MENU knob to select ON, and press the MENU knob.

This enables the function that adjusts the reference value during shooting. You can adjust the value by simply turning the MENU knob.

Leaving the MENU knob in the current position for a few seconds sets the reference value.

When the RM-B150/B750 Remote Control Unit is connected

The IRIS control knob of the RM-B150/B750 can be used for lens iris setting. In this case, the bar display (□) does not appear.

To adjust the iris sensitivity

When you use the VCL-719BXS lens (supplied with PDW-F335K), you usually need not adjust the iris sensitivity because lenses are equipped with iris sensitivity adjustment function.

In auto iris mode, if hunting or response delay happens, adjust the iris sensitivity using the iris sensitivity trimmer.

Example: For the lens (VCL-719BXS) supplied with the PDW-F335K

Iris sensitivity trimmer (labeled S, IRIS GAIN, etc.)

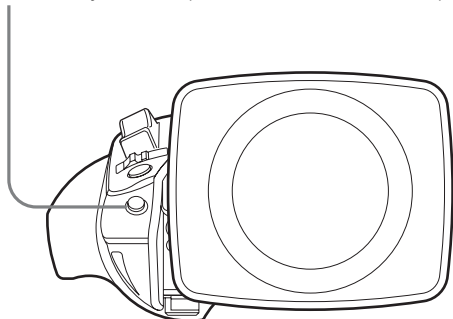

Remove the rubber cap on the front of the lens drive unit to reveal the iris sensitivity trimmer. Use a mini-screwdriver to turn the trimmer. Turn it clockwise to

increase the sensitivity, and turn it counterclockwise to decrease the sensitivity.

It is recommended that you check the iris sensitivity after replacing the lens.

Note

The optimum position for the iris sensitivity trimmer varies depending on the lens.

For more information, refer to the operating instructions of the lens (or contact the lens manufacturer).

Adjusting the Audio Level

Setting the AUDIO SELECT (CH-1/CH-2) switches to AUTO automatically adjusts the input levels of the audio signal to be recorded in audio channels 1 and 2.

To manually adjust the levels of the audio inputs from the AUDIO IN CH-1/CH-2 connectors

Proceed as follows to adjust the levels of the audio inputs from the AUDIO IN CH-1/CH-2 connectors, which are to be recorded in audio channels 1 and 2.

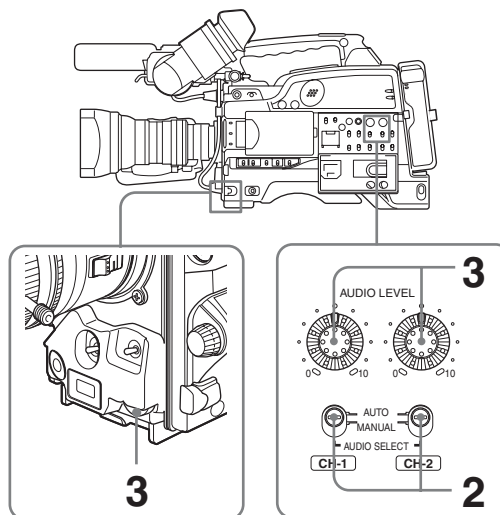

- 1 Select the audio channel that you want to record in.

For details, see “Selection of the recording audio input” on page 44.

- 2 Set the AUDIO SELECT (CH-1/CH-2) switch(es) corresponding to the audio channel(s) selected in step 1 to MANUAL.

- 3 With the AUDIO LEVEL knob on the side control panel and the AUDIO LEVEL knob on the front, adjust so that the audio level meter shows up to -20 dB for a normal input volume.

When the AUDIO IN switch is in the FRONT position, the input level of audio channel 1 and 2 is the value of the AUDIO LEVEL knob on the front panel of the unit. When the AUDIO IN switch is in the REAR or WIRELESS position, the level is the value of the AUDIO LEVEL knob on the rear panel of the unit.

You can select the knobs used in adjustments by changing the settings of MIC CH1 LEVEL, MIC CH2 LEVEL, REAR1/WRR LEVEL, and REAR2/WRR LEVEL on the AUDIO-2 page of the MAINTENANCE menu.

When the top bar (0 dB) turns on, the audio level is too high. There is no problem if the second bar from the top turns on.

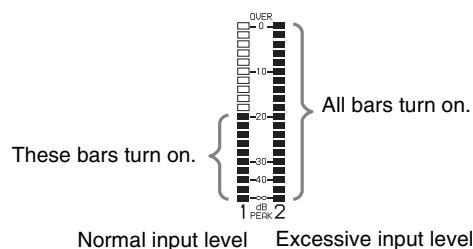

Setting the Time Data

To set the timecode

The timecode setting range is from 00:00:00:00 to 23:59:59:29 (hours: minutes: seconds: frames).
(When the frame frequency is 23.98P: from 00:00:00:00 to 23:59:59:23)

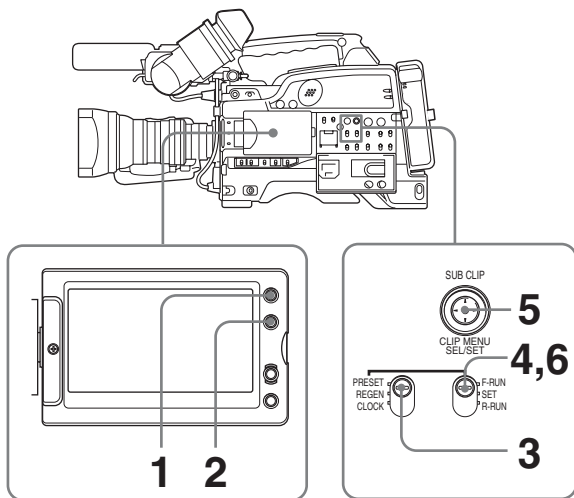

- 1 Press the DISPLAY/EXPAND button of the LCD monitor so that the status display appears.

- 2 Press the COUNTER/CHAPTER button of the LCD monitor to display TCG on the time counter display section.
- 3 Set the PRESET/REGEN/CLOCK switch to PRESET.
- 4 Set the F-RUN/SET/R-RUN switch to SET.
The first (leftmost) digit of timecode flashes.

- 5 Use the SEL/SET button (four-way arrow key) to set the timecode value including the last (rightmost) digit of the timecode.

To reset the timecode value to 00:00:00:00, press the RESET button on the right side of the LCD monitor.

Note

When the frame frequency of this unit is 23.98P, a timecode frame count can only be set to a multiple of 4 (0, 4, 8, 12, 16, or 20).

- 6 Set the F-RUN/SET/R-RUN switch to the desired operating mode for the timecode generator.

F-RUN: Free run. The timecode generator keeps running.

R-RUN: Recording run. The timecode generator runs only while recording.

To set the DF (drop-frame)/NDF (non-drop-frame) mode

You can select the drop-frame (DF) mode or non-drop-frame (NDF) mode on the TIME CODE page of the MAINTENANCE menu.

Note

When the frame frequency of this unit is 23.98P, recorded timecode is always non-drop-frame (NDF).

To make the timecode consecutive

When the F-RUN/SET/R-RUN switch is set to R-RUN, recording a number of scenes to the disc normally produces consecutive timecode. However, once you remove the disc and record to another disc, the timecode will no longer be contiguous even when you use again the original disc for recording.

In this case, by setting the PRESET/REGEN/CLOCK switch to REGEN, the timecode can be made continuous.

To save the actual time in the timecode

Setting the PRESET/REGEN/CLOCK switch to CLOCK saves the actual time in the timecode. When it is necessary to set the actual time, use the TIME/DATE page of the OPERATION menu.

For details, see “Setting the Date and Time of the Internal Clock” on page 34.

Note

When the frame frequency of this unit is 23.98P, the recorded timecode does not coincide with real time.

To set the user bits

By setting the user bits (up to 8 hexadecimal digits), you can record user information such as the date, time, or scene number on the timecode track.

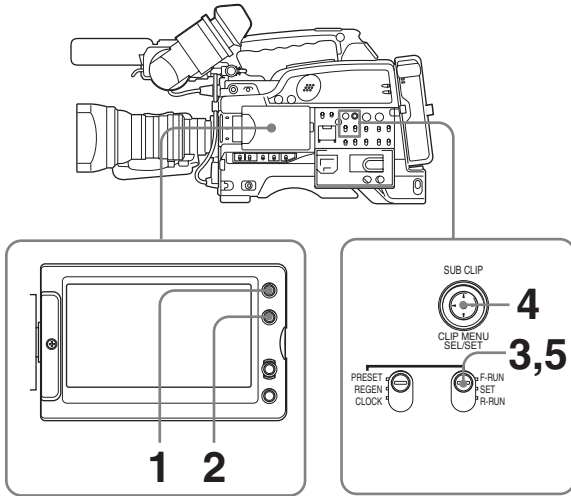

- 1** Press the DISPLAY/EXPAND button of the LCD monitor so that the status display appears.
- 2** Press the COUNTER/CHAPTER button on the LCD monitor to display UBG in the time counter display section.
- 3** Set the PRESET/REGEN/CLOCK switch to PRESET.
- 4** Set the F-RUN/SET/R-RUN switch to SET.
The first (leftmost) digit flashes.
- 5** Use the SEL/SET button (four-way arrow key) to set the timecode value including the last (rightmost) digit of timecode.

Hexadecimal digits A to F are displayed as A to F in capital letters.
To reset the timecode value to 00 00 00 00, press the RESET button on the right side of the LCD monitor.
- 6** Set the F-RUN/SET/R-RUN switch to the desired operating mode for the timecode generator.

F-RUN: Free run. The timecode generator keeps running.

R-RUN: Recording run. The timecode generator runs only while recording.

To lock the timecode to an external source

You can synchronize the internal timecode generator of this camcorder with an external generator for the regeneration of an external timecode. You can also synchronize the timecode generators of other camcorders/VTRs with the internal generator of this camcorder. Input the timecode to the TC connector on the rear connector panel, and set the IN/OUT selector switch to IN. When using this unit as the reference device, set the IN/OUT selector switch to OUT, to output timecode from the TC connector.

Connections for timecode synchronization

Connect both the reference video signal and the external timecode as illustrated below.

Example 1: Synchronizing with an external timecode

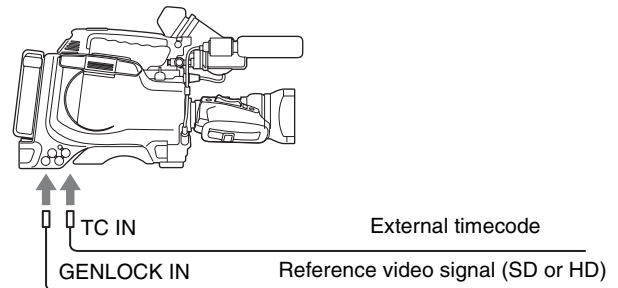

Example 2: Connecting two units, and using one as the reference

Notes

- When making the following connections, set the frame frequency to the same value on both units. Wait until the reference camcorder becomes stable (a state where a normal picture appears on the viewfinder screen or the LCD monitor), and then connect the other camcorders.
- When the frame frequency of this unit is 23.98P, make sure that the reference unit is either recording or in the recording stopped state.

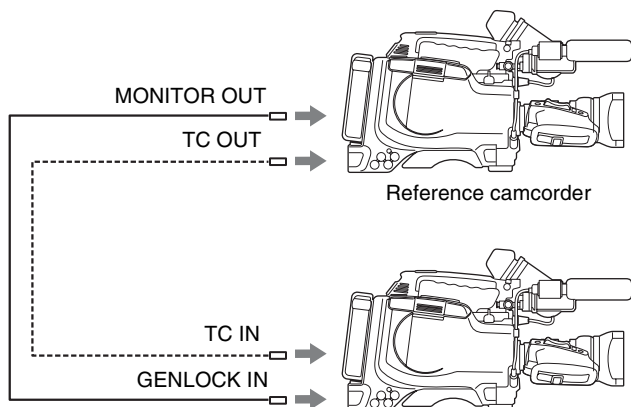

To synchronize the timecode

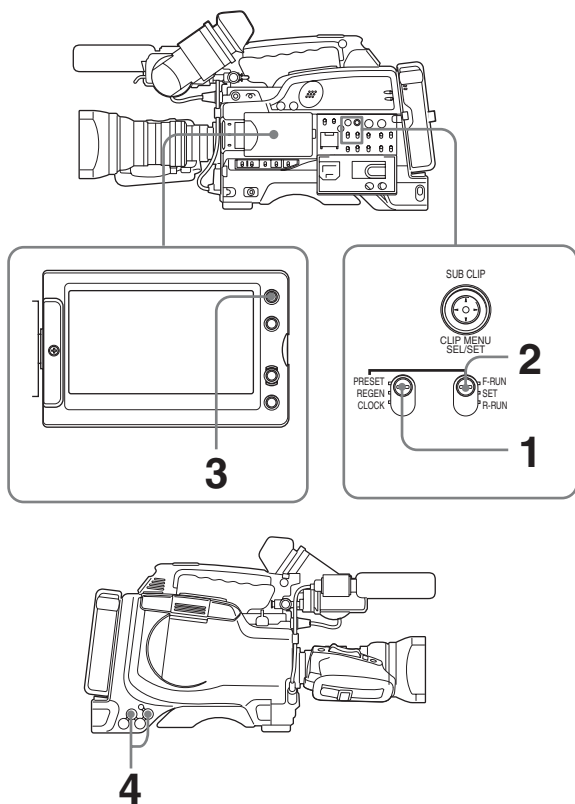

- 1** Set the PRESET/REGEN/CLOCK switch to PRESET.
- 2** Set the F-RUN/SET/R-RUN switch to F-RUN.
- 3** Press the DISPLAY/EXPAND button of the LCD monitor to display TCG on the time counter display section.
- 4** Depending on the frame frequency setting of this unit, supply the reference timecode and reference video signal shown in the following table to the TC IN connector ¹⁾ and GENLOCK IN connector, respectively. The input reference timecode and reference video signal must meet the phase relationship requirements of the the SMPTE timecode

standard. (Excluding the case where the frame frequency is 23.98P.)

1) Input to the TC connector, and set the IN/OUT selector switch to IN.

| Frame frequency of this unit | Acceptable reference video signal frame frequency (HD or SD) | Acceptable timecode |
|---------------------------------------|--|---------------------|
| 60i ^{a)} , 30P ^{b)} | 59.94i | 30 frames |
| 50i, 25P | 50i | 25 frames |
| 23.98P | 59.94i ^{c)} | 24 frames |

- a) More precisely 59.94i
- b) More precisely 29.97P
- c) External synchronization is not available for 23.97PsF.

This operation synchronizes the internal timecode generator with the external timecode. After about 10 seconds, you can disconnect the external timecode without losing the synchronization. However, there will be noise on the recorded image if you connect or disconnect the timecode signal during recording.

Notes

- When the frame frequency of this unit is 23.98P, a discrepancy of ± 1 frame with the externally locked timecode may arise.
- When you finish the above procedure, the internal timecode is immediately synchronized with the external timecode and the time counter display will show the value of the external timecode. However, wait for a few seconds until the sync generator stabilizes before recording.
- If this unit cannot be genlocked to the reference video signal, the internal timecode is not correctly synchronized with the external timecode. Until this unit is genlocked to the input reference video signal, the output video signal from this unit may break up.
- When the internal timecode generator is set to F-RUN mode, the precision of the synchronization may be reduced if you turn the POWER switch off and on or keep the camcorder turned off for a long time.

About user bits settings during timecode synchronization

When the timecode is synchronized, only the time data is synchronized with the external timecode value. Therefore, the user bits can have their own settings for each camcorder.

To release the timecode synchronization

First disconnect the external timecode, then set the F-RUN/SET/R-RUN switch to R-RUN.

To change the power supply from the battery pack to an external power supply during timecode synchronization

To maintain a continuous power supply, connect the external power supply to the DC IN connector before removing the battery pack. You may lose timecode synchronization if you remove the battery pack first.

Camera synchronization during timecode synchronization

During timecode synchronization, the camera is genlocked to the reference video signal input from the GENLOCK IN connector.

Setting for Special Shooting Cases

Depending on the shooting conditions, set the camcorder appropriately referring to the following table.

| Shooting conditions | Setting and effect |
|--|--|
| When adjusting for skin detail or tone (Example: When shooting to hide skin details) | Setting: See “To correct skin detail” on page 64. Effect: This adjusts the skin detail or tone to a designated active area. |
| The 3200K preset white balance makes the picture reddish. | Setting: Change the setting of the preset white balance on the PRESET WHT page of the MAINTENANCE menu. Effect: This prevents the picture from reddening. |

To correct skin detail

- 1 Set SKIN AREA IND to ON on the SKIN DETAIL page of the PAINT menu.

For details on menu operations, see “Basic Menu Operations” on page 130.

- 2 Set SKIN DETECT on the SKIN DETAIL page of the PAINT menu.

This causes the area detect cursor to be shown in the viewfinder screen.

- 3 Place the area detect cursor on the target, then execute SKIN DETECT.

This designates the correction area, which is indicated by a zebra pattern.

- 4 Change the value of SKIN DTL WIDTH (0 to 359) on the SKIN DETAIL page so that the zebra pattern may be displayed in the target area.

Set the correction level beforehand using the SKIN DETAIL LVL item on the SKIN DETAIL page.

- 5 When the setting is finished, set SKIN AREA IND to OFF on the SKIN DETAIL page.

Deleting Clips

With this camcorder you can delete clips one at a time, in sequence from the last recorded clip, or you can delete all clips in a single operation.

You can use the THUMBNAIL menu to delete the selected clip or all clips. For details, see “Deleting Clips” on page 82.

Note

Locked clips cannot be deleted.

To delete the last recorded clip

Proceed as follows.

(How to select an item in the menu screen: Turn the MENU knob to move the ➔ mark to the desired item.)

- 1 Display the DISC page of the USER (or OPERATION) menu, and press the MENU knob.

For details on menu operations, see “Basic Menu Operations” on page 130.

- 2 Select DELETE LAST CLIP, and press the MENU knob.

The message “DELETE OK? YES ➔ NO” appears.

- 3 To execute the deletion, select YES, and press the MENU knob again.

The last recorded clip is deleted.

- 4 By repeating steps 2 and 3, you can delete any number of clips in sequence from the last recorded clip.

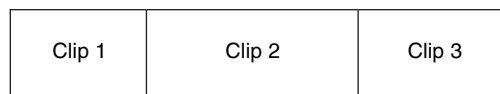

Clips can be deleted in the sequence 3 → 2 → 1.

To delete all clips within the disc

Note

The following procedure deletes all unlocked clips.

Proceed as follows.

(How to select an item in the menu screen: Turn the MENU knob to move the ➔ mark to the desired item.)

- 1 Display the DISC page of the USER (or OPERATION) menu, and press the MENU knob.

For details on menu operations, see “Basic Menu Operations” on page 130.

- 2 Select DELETE ALL CLIPS, and press the MENU knob.

The message “DELETE OK? YES ➔ NO” appears.

- 3 To execute the deletion, select YES, and press the MENU knob.

This deletes all clips within the disc.

Recording Shot Marks

With this unit, you can record two types of shot mark (shot mark 1 and shot mark 2) on the disc.

Recording shot marks for scenes containing important images and sounds enables quick access to the marked points. This increases editing efficiency.

The FIND MODE item on the ESSENCE MARK page of the MAINTENANCE menu allows you to specify whether to enable jumps to essence marks, or whether jumps are to clip starting frames only.

To specify shot marks to be recorded on the disc

To select whether or not to record shot mark 1 and shot mark 2, use the following procedure.

With the factory default setting, both are recorded.

(How to select an item in the menu screen: Turn the MENU knob to move the ➔ mark to the desired item.)

- 1 Display the ESSENCE MARK page of the MAINTENANCE menu, and press the MENU knob.

For details on menu operations, see “Basic Menu Operations” on page 130.

| | |
|------------------|--------|
| M040ESSENCE MARK | TOP |
| ➔SHOT MARK 1 | : ON |
| SHOT MARK 2 | : ON |
| INDEX PIC. POS. | : 0SEC |
| FIND MODE | : R.ST |

- 2 Select SHOT MARK 1 or SHOT MARK 2, and press the MENU knob.

- 3 Turn the MENU knob to select ON (record the shot mark) or OFF (do not record the shot mark), and press the MENU knob.

Recording a SHOT MARK 1

Press the RET button on the lens once.

“ShotMark1” appears near the timecode display on the viewfinder screen for about one second.

If SHOT MARK 1 recording has been assigned to one of the ASSIGN switches, you can also use that switch to record a SHOT MARK 1.

See “Assigning Functions to ASSIGN Switches” on page 143 for more information about how to make assignments.

Recording a SHOT MARK 2

Press the RET button twice in quick succession during recording or playback.

“ShotMark2” appears near the timecode display on the viewfinder screen for about one second.

If SHOT MARK 2 recording has been assigned to one of the ASSIGN switches, you can also use that switch to record a SHOT MARK 2.

Setting the Thumbnail Image at Recording Time

When you record a clip, you can specify which frame to use as the clip’s thumbnail image (*see page 76*).

For example, if all clips have the same image in their first frames, you can specify a frame a few seconds after the start of the clip, so that all thumbnails will not show the same image.

Note

The factory default setting is to use the first frame in the clip as the thumbnail.

Proceed as follows.

(How to select an item in the menu screen: Turn the MENU knob to move the ➔ mark to the desired item.)

- 1 Display the ESSENCE MARK page of the MAINTENANCE menu, and press the MENU knob.

For details on menu operations, see “Basic Menu Operations” on page 130.

```

M040ESSENCE MARK TOP
SHOT MARK 1 : ON
SHOT MARK 2 : ON
→INDEX PIC. POS. : 0SEC
FIND MODE : R.ST

```

- 2** Select INDEX PIC. POS., and press the MENU knob.

The → mark changes to a ● mark, and the ● mark changes to a ? mark.

```

M040ESSENCE MARK TOP
SHOT MARK 1 : ON
SHOT MARK 2 : ON
●INDEX PIC. POS. : ?5SEC
FIND MODE : R.ST

```

- 3** Turn the MENU knob to select the desired time.

You can select the time in units of 1 second over the range 0SEC to 10SEC.

- 4** Press the MENU knob.

The selection is confirmed.

Note

You can also change the thumbnail image at playback time. For details, see “Switching the Information Displayed in the Thumbnail Screen” on page 77.

Recording – Advanced Operations

Time-lapse Video Recording (Interval Rec Function)

The interval recording (Interval Rec) function is effective for shooting objects that move very slowly. As shown in the following figure, you need to set the recording time for one recording session (NUMBER OF FRAME) and the total time consisting of one recording session and the following interval (INTERVAL TIME).

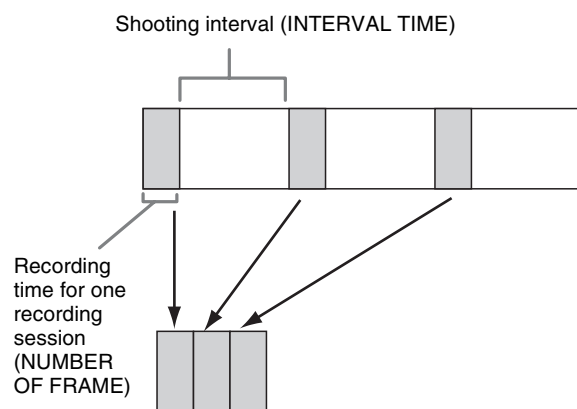

A pre-lighting function is available. This function automatically turns on the light before recording starts, which allows you to record pictures under stable light and color temperature conditions.

Making settings before shooting

To record in Interval Rec mode, you need to set the related items beforehand as follows.

(How to select an item in the menu screen: Turn the MENU knob to move the → mark to the desired item.)

- 1** Set INTERVAL REC to ON on the SPECIAL EFFECTS page of the OPERATION menu.

For details on menu operations, see “Basic Menu Operations” on page 130.

```

→002●SPECIAL EFFECTS TOP
CLIP CONT REC : OFF
INTERVAL REC : ON
INTERVAL TIME : 1SEC
NUMBER OF FRAME : 1F
NUMBER OF TIMES : CONT
PRE-LIGHTING : OFF
PICTURE CACHE : OFF
CACHE REC TIME : 8-10s

```

The camcorder is put in Interval Rec mode. The TALLY indicator (green) in the viewfinder flashes

(one flash/second) while the camcorder is in this mode.

2 Select INTERVAL TIME, and press the MENU knob.

3 Turn the MENU knob to set the interval time.

You can select the value of interval time from 1SEC to 10SEC, 15SEC, 20SEC, 30SEC, 40SEC, 50SEC, 1MIN to 10MIN, 15MIN, 20MIN, 30MIN, 40MIN, 50MIN, 1H to 4H, 6H, 12H, and 24H.

Here “SEC” means seconds, “MIN” means minutes, and “H” means hours.

4 Select NUMBER OF FRAME, and press the MENU knob.

5 Turn the MENU knob to select the length of time of one recording session in units of frames, and press the MENU knob.

You can select from 1F, 3F, and 6F.

6 Select NUMBER OF TIMES, and press the MENU knob.

7 Turn the MENU knob to select the number of recording sessions, and press the MENU knob.

You can select from CONT (continuous), 50, 100, 200, 300, 500, 800, and 1000.

8 If you want the light to automatically turn on before you start recording, select PRE-LIGHTING and press the MENU knob.

9 Turn the MENU knob to specify the time in units of second (how long before the start of recording the light should turn on automatically), and press the MENU knob.

You can select from OFF, 2SEC, 5SEC, and 10SEC.

Notes

- Set the LIGHT switch on the camcorder to AUTO to turn on the light before recording. The light switch must also be set to ON. With these settings, the light turns on and off automatically. However, the light remains on continuously if the off time is less than 5 seconds.
- When the LIGHT switch is set to MAN and the light switch is set to ON, the light remains on continuously.

Note

The camcorder exits Interval Rec mode whenever it is powered off. However, the settings of INTERVAL TIME,

etc. are maintained. You do not need to set them again the next time you use Interval Rec mode.

Shooting and recording in Interval Rec mode

1 After performing the basic procedures for shooting and recording, following the instructions in “*Making settings before shooting*” on page 66, secure the camcorder so that it will not move.

2 Press the REC button on the camcorder or the REC button on the lens.

The camcorder starts recording in Interval Rec mode. When you use the pre-lighting function, recording starts after the light is switched on.

While recording in Interval Rec mode, the TALLY indicator (green) in the viewfinder flashes (4 flashes/second), and “INTERVAL” and other characters appear on the viewfinder screen.

While recording, the REC indicator in the viewfinder lights.

To interrupt interval recording

Press the REC button on the camcorder or the REC button on the lens.

Recording in Interval Rec mode stops. Press the REC button again to start recording in Interval Rec mode again.

To end interval recording

You can exit Interval Rec mode by setting the POWER switch to OFF or setting INTERVAL REC to OFF on the SPECIAL EFFECTS page of the OPERATION menu.

Notes on Interval Rec mode

Audio

In Interval Rec mode, audio recording is not possible.

Playback control buttons

While recording in Interval Rec mode, you cannot use the playback control buttons (EJECT, F REV, PLAY/PAUSE, F FWD, PREV, STOP and NEXT). To use these buttons, stop recording by pressing the REC button on the camcorder or the REC button on the lens.

Menu operation

While recording in the Interval Rec mode, the INTERVAL TIME and other settings cannot be changed. To change the settings, stop recording by pressing the REC button on the camcorder or the REC button on the lens.

Timecode

In Interval Rec mode, the internal timecode generator operates in R-RUN mode.

Starting a Shoot with a Few Seconds of Pre-Stored Picture Data (Picture Cache Function)

The camcorder has a large capacity internal memory, in which you can cache the last few seconds (maximum 12 seconds) of captured video and audio, so that recording starts from a point just before you press the REC START button or VTR button on the lens.

Setting the Picture Cache time/Picture Cache mode

To record in Picture Cache mode, you need to turn on Picture Cache mode and set the picture data storage time (Picture Cache time) using the OPERATION menu. The Picture Cache time determines the number of seconds recorded from the Picture Cache, counting back from the time when you press the REC START button or the VTR button on the lens to start recording. However, the number of seconds actually recorded from the Picture Cache may be shorter immediately after the setting of the VDR SAVE/STBY switch is changed, and in the special situations explained in the following notes.

Notes

- The contents of Picture Cache memory are unstable for a short time immediately after you select Picture Cache mode or change the Picture Cache time. Therefore, if you put the unit into recording mode by pressing the REC START button or the VTR button on the lens immediately after such operation, pictures just before such operation cannot be recorded. Also, a certain amount of time is required to actually start recording to a disc immediately after you insert a disc and when the VDR switch is set to SAVE. In these cases, the number of seconds that can actually be recorded from the Picture Cache may be fewer than the specified Picture Cache time.
- During playback or recording review, no data is saved to the Picture Cache memory. Thus it is not possible to use this function to rerecord the last few seconds of material from playback or recording review.

To turn Picture Cache mode on, proceed as follows.

(How to select an item in the menu screen: Turn the MENU knob to move the \blacktriangleright mark to the desired item.)

- 1 Display the SPECIAL EFFECTS page of the OPERATION menu (see page 108), and press the MENU knob.

For details on menu operations, see “Basic Menu Operations” on page 130.

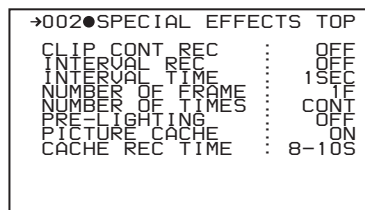

- 2 Turn the MENU knob to move the \blacktriangleright mark to “PICTURE CACHE”.

- 3 Press the MENU knob.

The \blacktriangleright mark on the left of “PICTURE CACHE” changes to a \bullet mark and the \bullet mark on the left of the setting changes to a ? mark.

- 4 Turn the MENU knob until “ON” appears.

When “ON” appears, the camcorder is in Picture Cache mode, where picture, sound, and time code are constantly saved in memory. The TALLY indicator (green) is on while picture data is being stored in memory.

- 5 Press the MENU knob.

The \bullet mark changes to a \blacktriangleright mark and the ? mark changes to a \bullet mark.

- 6 Turn the MENU knob to move the \blacktriangleright mark to “CACHE REC TIME”.

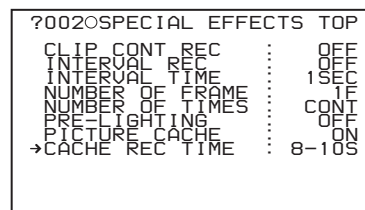

- 7 Press the MENU knob.

The \blacktriangleright mark on the left of “CACHE REC TIME” changes to a \bullet mark and the \bullet mark on the left of the setting changes to a ? mark.

- 8 Turn the MENU knob until the desired Picture Cache time appears.

As you turn the MENU knob, the Picture Cache time changes in the following sequence: 0-2s \rightarrow 2-4s \rightarrow 4-6s \rightarrow 6-8s \rightarrow 8-10s \rightarrow 10-12s.

- 9 Press the MENU knob.

The \bullet mark changes to a \blacktriangleright mark and the ? mark changes to a \bullet mark.

10 To end the menu operation, set the MENU ON/OFF switch to OFF.

The menu disappears, and the display indicating the current status of the camcorder appears along the top and bottom of the screen.

Settings made in Picture Cache mode are maintained until changed.

You can turn Picture Cache mode on and off by assigning the Picture Cache ON/OFF function to one of the assignable switches (ASSIGN 1/2/3/4), and pressing the switch.

For details about assignable switches, see “Assigning Functions to ASSIGN Switches” on page 143.

Notes

- In Picture Cache mode, the internal time code generator operating mode is always F-RUN regardless of the setting of the F-RUN/SET/R-RUN switch.
- The Interval Rec function is turned off automatically whenever you turn the Picture Cache function on.

Camcorder operations in Picture Cache mode

The recording procedure in Picture Cache mode is basically the same as that for normal recording. However, note the following differences.

- When you record in Picture Cache mode, the picture you are shooting now is recorded to disc after the picture data stored in memory (equal to the Picture Cache time) is recorded to disc. For this reason, disc access may continue for a short time after you press the REC START button to stop recording. During this time, the playback control buttons are disabled, as in recording mode. Also, if you press the REC START button or the VTR button on the lens to restart recording during this time, a separate clip is recorded.
- When you press the REC START button or the VTR button on the lens to restart recording during disc access, the start point of the recorded clip may be later than the Picture Cache time, especially when there are a large number of clips recorded on the disc. In Picture Cache mode, you should avoid stop and start recording operations in quick succession.
- The time disc access stops after the REC START button is pressed equals the Picture Cache time. However, if you start recording within the Picture Cache time immediately after selecting Picture Cache mode, changing the Picture Cache time or performing playback or recording review, the picture data for the duration of the Picture Cache time will not be stored in memory. Thus, the time disc access stops after the STOP button is pressed becomes shorter than the Picture Cache time.
- In Picture Cache mode, you cannot set the F-RUN/SET/R-RUN switch to SET to make time code settings. To make time code settings, first exit Picture Cache mode.

When power is lost during recording

- When the power is turned off during recording, the camcorder will switch itself off after disc access has continued for a few seconds to record the picture in the instant of power off.
- If you remove the battery, pull out the DC cable, or cut power to the AC adaptor during recording, video and audio stored in memory will be lost without being recorded to the disc. For this reason, make sure you do not change the battery while recording.

Assigning User-Defined Clip Titles Automatically

About the Automatic Title Generation Function

By default, clips on each disc are assigned names in the range C0001.MXF to C0300.MXF. For this reason, two discs can contain clips with the same names. The automatic title generation function allows you to assign titles to all of the clips on several discs, which facilitates clip management.

For example, if the titles TITLE00001 to TITLE00020 are assigned to clips C0001.MXF to C0020.MXF on disc 1, then the titles TITLE00021 to TITLE00037 are assigned to clips C0001.MXF to C0017.MXF on disc 2.

Titles are made up of prefixes, up to 10 characters in length, and five-digit serial numbers such as “TITLE 00001”.

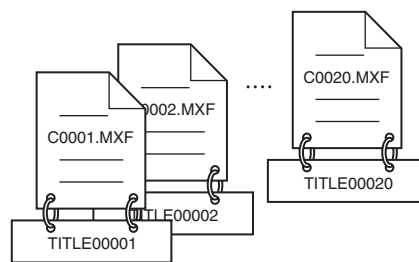

Clips recorded on Disc 1

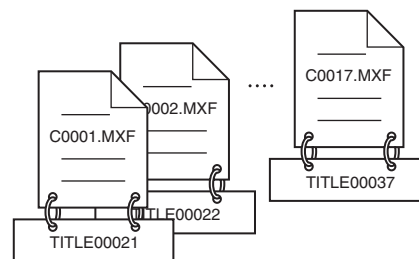

Clips recorded on Disc 2

Setting the title prefix

You can assign title prefixes by choosing from a prefix list stored in internal memory, or by entering the prefix directly.

However, to choose from a prefix list, you must create the list beforehand on a computer and transfer it to the unit's internal memory with a "Memory Stick".

Setting the initial value of the serial number

The initial value of the serial number can be set to 00001 (the default) or to any other number. The number is automatically incremented by 1 each time you record a clip. When it reaches 99999, it returns to 00001 for the next clip.

Note

Duplicate clip titles can be generated depending on the serial number setting, for example if you reset the serial number to the original value after recording several clips. Care should be taken when setting the serial number.

To assign user-defined titles automatically when clips are recorded

On the CLIP TITLE page of the OPERATION menu, set TITLE to ENABL.

For details on menu operations, see "Basic Menu Operations" on page 130.

The following items appear.

```

0050CLIP TITLE          TOP
→TITLE                  :●ENABL
SELECT PREFIX          :EXEC
CLEAR NUMERIC          :EXEC
LOAD PREFIX DATA     :EXEC
PREFIX                 :TITLE
NUMERIC                :00001
  
```

Clip titles will be generated automatically if you record in this state.

The title of the next clip to be recorded will be a combination of the prefix in the PREFIX field and the serial number in the NUMERIC field.

To use any alphanumeric character string, see the following.

To enter a title prefix directly

Proceed as follows.

- 1 On the CLIP TITLE page, select "PREFIX" and then press the MENU knob.

A prefix string appears.

```

0050CLIP TITLE          TOP
TITLE                  :ENABL
SELECT PREFIX          :EXEC
CLEAR NUMERIC          :EXEC
LOAD PREFIX DATA     :EXEC
●PREFIX                 :TITLE
123456789             :
=0ABCDEFGHIJKLMNORSTUW
WXYZIJ^_abcdefghijklmnop
rstuvwxyz{~           :
INS DEL RET           :ESC END
  
```

- 2 Move the ■ mark to the character you want to change and then press the MENU knob.
- 3 Turn the MENU knob to move the ■ mark to the desired character in the list of selectable characters, and then press the MENU knob.
- 4 Repeat steps 2 and 3 to enter the remaining characters.
- 5 When you have finished entering the prefix, turn the MENU knob to move the ■ mark to END, and then press the MENU knob.

The camcorder exits prefix input mode, and the original CLIP TITLE page appears.

To set the initial value of the clip title serial number

You can set the initial value of the clip title serial number to 00001 (default) or to any five-digit value.

To return the initial value to 00001

Proceed as follows.

- 1 On the CLIP TITLE page, select "CLEAR NUMERIC" and then press the MENU knob.

The message "CLEAR OK? YES ▶ NO" appears.

- 2 Select YES and then press the MENU knob.

The value in the "NUMERIC" field returns to "00001" (default).

To set the initial value to any number

Proceed as follows.

- 1 On the CLIP TITLE page, select "NUMERIC" and then press the MENU knob.

A digit selection screen appears.

```

0050CLIP TITLE
0123456789
INS DEL RET           ESC END
CLEAR NUMERIC        EXEC
LOAD PREFIX DATA   EXEC
PREFIX                 TITLE
●NUMERIC              :00001
  
```

- 2 Move the **■** mark to the digit you want to change and then press the MENU knob.
- 3 Turn the MENU knob to move the **■** mark to the desired digit in the list of selectable digits, and then press the MENU knob.
- 4 Repeat steps 2 and 3 to enter the remaining digits.
- 5 When you have finished entering the value, turn the MENU knob to move the **■** mark to END, and then press the MENU knob.

The camcorder exits numeric input mode, and the original CLIP TITLE page appears.

To check the titles of recorded clips

Press the THUMBNAIL button to display the thumbnail screen, and then select the clip whose title you want to check.

The title of the selected clip appears in the upper left of the screen.

See “Cuing up with sub clip thumbnails” (page 80) for more information about the thumbnail screen.

Notes

- It is not possible to specify 00000 as the initial value. Even if you enter 00000, the value is reset to 00001 when the camcorder exits numeric input mode.
- The value of the serial number is incremented by 1 every time a title is generated. When the value reaches 99999, the next number restarts from 00001.
- Duplicate clip titles can be generated if you reset the serial number after recording several clips or the same is true depending on the value setting. Care should be taken when setting the serial number.

Assigning User-Defined Clip and Clip List Names

The following standard format names are assigned automatically to clips and clip lists that are created or recorded by XDCAM devices.

Clips: C0001 to C0300

Clip lists: E0001E01 to E0099E01

You can use the supplied PDZ-1 Proxy Browsing Software to assign user-defined names instead of the standard format names. Assigning meaningful names to clips and clip lists can facilitate file management. You can also use this unit’s “AUTO TITLING” function to assign user-defined names to clips.

To assign clip names on this unit

The title assigned to clip becomes its clip name (file name).

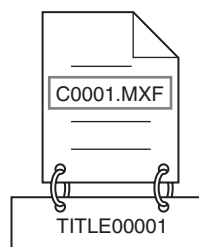

When sub item “AUTO NAMING” is set to “C****”

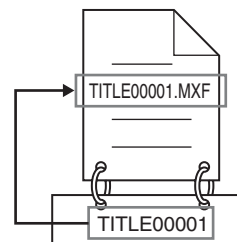

When sub item “AUTO NAMING” is set to “TITLE”

Proceed as follows.

(How to select an item in the menu screen: Turn the MENU knob to move the **▶** mark to the desired item.)

- 1 Set TITLE on the CLIP TITLE page to “ENABL” (see page 70).

For details on menu operations, see “Basic Menu Operations” on page 130.

- 2 Display the FILE NAMING page of the OPERATION menu, and then press the MENU knob.

The current setting parameters appear at the left of the screen.

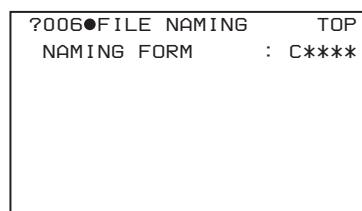

- 3 Turn the MENU knob to select “NAMING FORM”, and then press the MENU knob.

- 4 Turn the MENU knob to display “FREE”, and then press the MENU knob.

You are now able to use clips and clip lists with user-defined names.

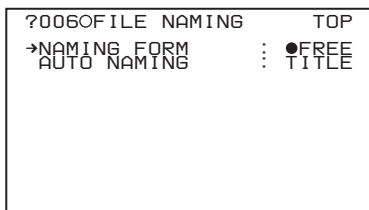

- 5** Turn the MENU knob to select “AUTO NAMING”, and then press the MENU knob.

C**:** Assign standard format clip names automatically.

TITLE: Assign clip titles as clip names.

- 6** Turn the MENU knob to display “TITLE”, and then press the MENU knob.

The same name will now be given to newly recorded clips.

Note

When the first letter of the title setting on the CLIP TITLE menu is a space or period (.), the clip name is the title string minus the first letter.

To enable clip and clip list renaming by FAM

Carry out steps **2** to **6** of “To assign clip names on this unit”.

It is now possible to write, transfer, and rename clips and clip lists with user-defined names over file access mode (FAM) connections (*see page 158*).

To rename a clip, execute “Rename” on a clip with the extension “.MXF” in the Clip folder.

The “.MXF” extension cannot be changed.

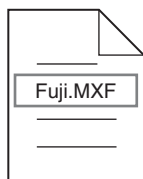

Clip renaming by FAM is enabled

To rename a clip list, execute “Rename” on a clip list with the extension “.SMI” in the Edit folder.

The “.SMI” extension cannot be changed.

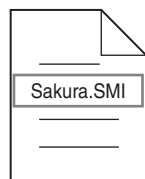

Clip list renaming by FAM is enabled

To check clip names

Press the THUMBNAIL button to display the thumbnail screen, and select the clip whose name you want to check.

The name of the selected clip appears at the upper left of the screen.

However, when the clip has a title, the title is displayed instead. Titles are enclosed in double quotation marks (“”).

See “Thumbnail Search” (page 76) for more information about the thumbnail screen.

Notes

- Items in the upper left of the screen are displayed in the following order of priority.
Title > user-assigned clip name > standard clip name

Therefore, the display changes as follows, depending on whether a clip has a title.

- The title is displayed for clips recorded on this unit which have titles.
- The user-assigned or standard clip name is displayed for clips which do not have titles.
- On XDCAM devices¹⁾ with firmware earlier than version 1.4, clips with user defined names are displayed as “C5000” to “C9999” in the order of recording.
- Clip names and clip list names are converted as follows for display in the thumbnail screen and the CLIP menu.
 - If the clip name is longer than 15 characters, then the first 9 characters and the last 5 characters are displayed. Other characters are converted into □ symbols.
 - Lowercase characters are converted to uppercase.
 - Kanji and other multibyte characters and some symbols are converted into □ symbols. Sequences of □ symbols are converted into a single □ symbol. The following 21 symbols can be displayed.
.:?!#*/()+- & @ = < > % " ; _ \$

¹⁾ PDW-F350/F330, PDW-530/510, PDW-F70/F30, PDW-1500, PDW-R1, PDW-V1, PDW-D1, and PDW-70MD

Display example

JumpingDolphin_No103

↓
JUMPINGDO □ NO103

To check clip information (name, title, etc.) by using a menu

See “Basic Menu Operations” (page 130) for more information about menu operations.

Display the CLIP STATUS page of the DIAGNOSIS menu, and then press the MENU knob.

The current settings for each item are displayed on the right side.

```

→D03●CLIP STATUS      TOP
CLIP NO      : 001/010
NAME         : C0001
TITLE       : (PDW-F395)
RECORD DEVICE : PDW-F395
SERIAL      : 10001
DATE       : 08/01/06
TIME      : 15:00:05

```

To create a list of title prefix strings

Prepare the data beforehand according to the following rules.

File name

Assign the name “TITLES.TXT” to the file.

Input format

Enter title prefixes one at time, separated by newline (CRLF) characters.

Prefixes can be up to 10 characters long. A prefix file can contain up to 20 prefixes.

Allowable characters

- Digits: 0 to 9
- Alphabetic characters: a to z, A to Z
- The following symbols: !, #, \$, %, &, ', (,), ~, =, -, ^, @, [,], {, }, +, ; (semicolon), , (comma), . (period), _ (underscore)
- Space

Title prefix list example

```

Tennis<CRLF>
Basketball<CRLF>
Skiing_1<CRLF>
Skiing_2<CRLF>

```

To transfer a title prefix list to the unit's internal memory

Proceed as follows.

- 1 Copy the title prefix file (TITLES.TXT) to the following folder on the “Memory Stick”.

```
\\MSSONY\PRO\XDCAM\GENERAL\VAL_LIST
```

Note

This folder is created when you insert a “Memory Stick” into the camcorder. Do not create this folder yourself on a computer.

- 2 Insert a “Memory Stick” with the title prefix file (TITLES.TXT) into the “Memory Stick” slot of the camcorder.
- 3 On the CLIP TITLE page, select LOAD PREFIX DATA and then press the MENU knob.

“MEMORY STICK ACCESS” appears, and the file on the “Memory Stick” (TITLES.TXT) is transferred to the internal memory of the unit.

The message “COMPLETE!” appears when the transfer finishes.

Note

The message “FILE NOT FOUND!” appears if no list of title prefixes is found.

Check the location where the file is stored on the “Memory Stick”.

To select a prefix from the title prefix list

Proceed as follows.

- 1 On the CLIP TITLE page, select SELECT PREFIX and then press the MENU knob.

A list of up to 20 title prefixes appears.

```

?P00 TITLE PREFIX  ESC
001: Tennis
002: Basketball
003: Skiing_1
004: Skiing_2
005: Athletics
006: Aquatics
007: Cycling
008: Softball
009: Fencing
→010: Sailing

```

Note

When no list of title prefixes has been transferred to the internal memory of this unit, only the initial value “TITLE” appears.

- 2 Select the desired title prefix from the list, and then press the MENU knob.

The CLIP TITLE page appears again, and the selected prefix appears in the PREFIX field.

Recording with the Clip Continuous Rec Function

Normally, a clip is generated as an independent file every time recording starts and stops. The Clip Continuous Rec function allows you to continue recording to the same clip until the function is turned off, regardless of how many times recording starts and stops. This is convenient if you want to avoid generating a large number of short clips, or if you want to record without worrying about the limit on the number of clips (maximum 300). A REC START essence mark is recorded whenever recording starts, which makes it easy to find the recording start points.

(How to select an item in the menu screen: Turn the MENU knob to move the ► mark to the desired item.)

- 1 Set CLIP CONT REC on the SPECIAL EFFECTS page of the OPERATION menu to ON.

For details on menu operations, see “Basic Menu Operations” (page 130).

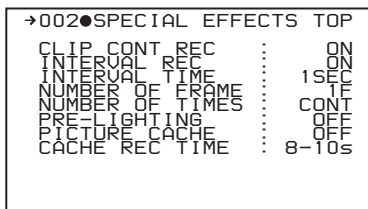

- 2 Select CLIP CONT REC, and press the MENU knob.
- 3 Press the MENU knob.

The VDR operation indicator in the viewfinder changes to “CONT”, and the Clip Continuous Rec function is enabled.

The Clip Continuous Rec ON/OFF function can be assigned to the ASSIGN 1/2/3/4 switches.

See “Assigning Functions to ASSIGN Switches” (page 143) for more information about the ASSIGN switches.

Note

The following recording modes cannot be enabled when this function is enabled.

- Interval Rec function
- Picture Cache function

To stop the function

Do one of the following to stop the Continuous Rec function. (A new clip will be generated the next time you start recording.)

- Perform a clip operation (lock or delete a clip)
- Make a network or FAM connection
- Eject the disc
- Change the recording format
- Power the unit off

To turn the function off

Set CLIP CONT REC on the SPECIAL EFFECTS page of the OPERATION menu to OFF.

Playback

Disc playback start position

Although this unit uses optical discs, it is designed to offer the most convenient features of tape playback by VTRs. One of these is the playback start position, which works in the same way as with tape, as described below.

After playback stop

The unit stops at the position where the STOP button was pressed.

Press the PLAY/PAUSE button to resume playback at the stop position.

After recording

The unit stops at the position where recording ended.

To play back a clip, press the PREV button to move to the start frame of any clip, or press the PREV button with the PLAY/PAUSE button held down to move to any position.

After disc insertion

The unit stops at the position of the disc when it was most recently ejected.

Press the PLAY/PAUSE button to resume playback at the most recent position.

The playback position is saved to the disc when the disc is ejected, which allows playback to start at that position whenever it is loaded into any XDCAM player.

Note

The playback position is not recorded to the disc if the disc is set to REC INH.

Normal Playback

By pressing the PLAY/PAUSE button, you can review any length of recording on the viewfinder screen in black and white or in color on the LCD monitor. There are two other ways to review the recording.

- Recording review: You can view the last two seconds of the recording on the viewfinder screen in black and white or in color on the LCD monitor.
- Using an external color video monitor: You can see the recording in color on a color video monitor without the need for any external adaptor.

You may also view the picture during a fast forward or fast reverse search.

See “Side control panel (inside the protection cover)” on page 19 for details about the switches and controls used to select the audio output signal and to adjust the audio level.

Deteriorating playback conditions

Deteriorating playback may be due to the following causes.

- **Scratches and dust on the disc surface**
This includes fingerprints, dust from the air, tar from cigarette smoke, and so on. Scratches and soiling which occur before recording are not a problem because they are registered in advance as defects, and recording avoids them. However, scratches and soiling which occur after recording can lead to deteriorating playback conditions.
- **Aging of disc recording layers**
Over several decades, the recording layers of optical discs can age and cause deteriorating playback conditions.
- **Deteriorating laser diodes performance**
The performance of the laser diodes used in optical heads can worsen with age, leading to deteriorating playback conditions.

Refer to the Maintenance Manual for an approximate guide to when it is time to replace optical heads.

To prevent playback conditions from deteriorating

Pay attention to the following points when handling discs.

- Do not open disc cartridges and touch discs directly with your hands.
- Do not store for long periods in locations which are dusty or exposed to air circulated by fans.
- Do not store for long periods under high temperatures or in locations exposed to direct sunlight.

If playback conditions have deteriorated

Read errors occur when playback conditions continue to deteriorate.

When a read error occurs, the message “DISC DEFECT” appears, the video freezes, and the audio output is suppressed.

If this happens, check the following points.

Whether the disc displays the same playback condition on other XDCAM devices: If so, the surface of the disc may be dirty or scratched, or the performance of the recording layers on the disc may have worsened due to age. Do not use discs with these symptoms.

Whether every disc inserted into an XDCAM device displays the same playback conditions: If so, the performance of the laser diodes may have deteriorated. Check the total optical output time.

Freezing a Picture During Playback

Proceed as follows.

- 1 Press the PLAY/PAUSE button to start playback.
- 2 Press the PLAY/PAUSE button again at the instant when you want to freeze the picture.

A frozen picture appears.

The time code is displayed in the time counter display section and the PLAY/PAUSE indicator changes from constant lighting to flashing (one flash/second).

- 3 To restart playback, press the PLAY/PAUSE button once again.

When remotely controlling the camcorder from an RM-B150/B750 Remote Control Unit

You can perform the same operation from the RM-B150/B750.

Checking the Last Two Seconds of the Recording (Recording Review)

If you press the RET button on the lens while recording is paused, the last two seconds of the recording are played back on the viewfinder screen and the LCD monitor. Use this function to check whether recording went smoothly. If you hold down the RET button on the lens, playback begins from the beginning of the clip. After playback, the camcorder is ready to start recording again.

When the LENS RET function is assigned to one of the ASSIGN 1/2/3/4 switches, you can use that switch in the same way as the RET button.

When the Clip Continuous Rec function is enabled, the review returns to the recording start point.

Checking the Recording on a Color Video Monitor

Connect a color video monitor to the VIDEO OUT connector or SDI OUT connector of the camcorder. By pressing the PLAY/PAUSE button, you can view the recorded picture.

On how to connect a color video monitor, see “Connecting an External Video Monitor” on page 46.

Thumbnail Search

Searching Using Thumbnails

To display the thumbnail images of all clips on the disc, and cue up a desired clip, proceed as follows.

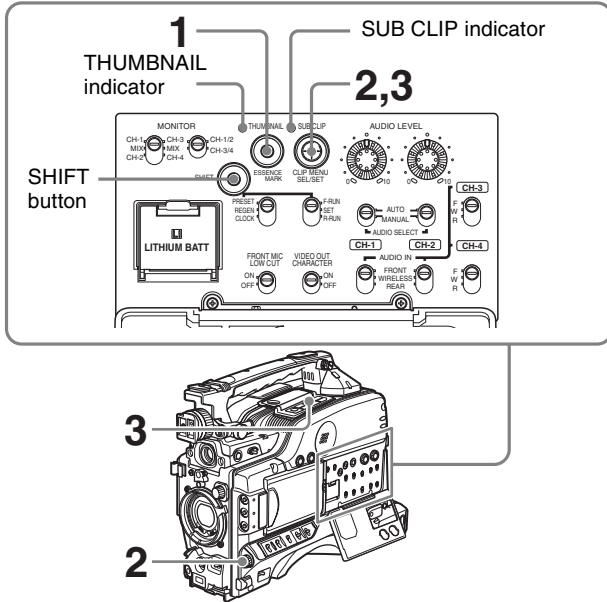

- 1 With the SUB CLIP indicator off, press the THUMBNAIL button to turn the THUMBNAIL indicator on.

If the SUB CLIP indicator is lit, you can turn it off by pressing the SEL/SET button to the upper side (the SUB CLIP side) with the SHIFT button held down.

If the menu screen is displayed, move the MENU switch to the OFF position and press the THUMBNAIL button.

If you set the MENU switch to ON while thumbnails are displayed, thumbnail display is replaced with menu display.

The thumbnails of all clips on the disc appear. (In the following descriptions, this is referred to as the “thumbnail screen”.)

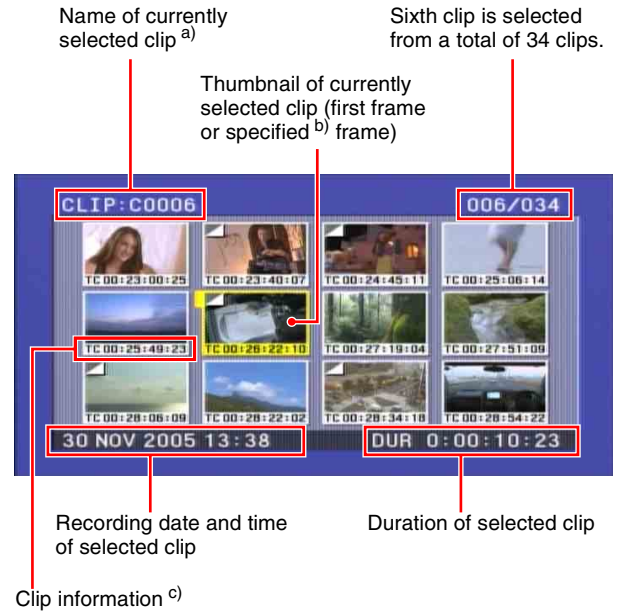

- a) When a title has been assigned to a clip (see page 69), the title is enclosed in double quotation marks, for example “TITLE00001”.
- b) On how to make a thumbnail image of the specified frame, see page 77.
- c) You can select the information to be displayed (see page 77). The factory default setting is display of timecode.

- 2 Use the SEL/SET button (four-way arrow key) or MENU knob to select the desired clip.

You can also select clips by the following operations.

Press the PREV button: When FIND MODE on the ESSENCE MARK page of the MAINTENANCE menu is set to R.ST, this moves to the previous REC START essence mark. When FIND MODE is set to CLIP, this moves to the start of the current clip, or moves to the first frame of the previous clip if the PREV button is pressed at the first frame of the current clip.

Press the NEXT button: When FIND MODE on the ESSENCE MARK page of the MAINTENANCE menu is set to R.ST, this moves to the next REC START essence mark. When FIND MODE is set to CLIP, this moves to the start of the next clip.

Press the PREV or NEXT button with the F REV or F FWD button held down: Move to the first or last clip.

Press the F REV/F FWD button: Move to the previous or next page.

- 3 To cue up the selected clip, press the SEL/SET button or the MENU knob. To start playback from the selected clip, press the PLAY/PAUSE button.

The remainder of the thumbnail selection process is the same as in steps 2 and 3 above.

To return to the previous screen

Press the THUMBNAIL button, turning the THUMBNAIL indicator off. At any point in the procedure you can return to the previous screen with this operation.

Note

The factory default setting is to use the first frame of a clip as its thumbnail image. At recording time, you can change this to another frame within 10 frames of the start of the clip (*page 65*). You can also change it to any frame at playback time (*page 77*). However, the thumbnail search function always cues up the first frame in a clip, even if the thumbnail image has been changed.

Switching the Information Displayed in the Thumbnail Screen

You can switch the clip information displayed at the bottom of thumbnails. You can also switch the display of thumbnail sequence numbers.

Note

The factory default setting is “TIME CODE”.

Proceed as follows.

- 1 With the thumbnail screen displayed, hold down the SHIFT button and press the SEL/SET button to the bottom side (the CLIP MENU side).

The CLIP menu appears.

See *page 94* for more information about the CLIP menu.

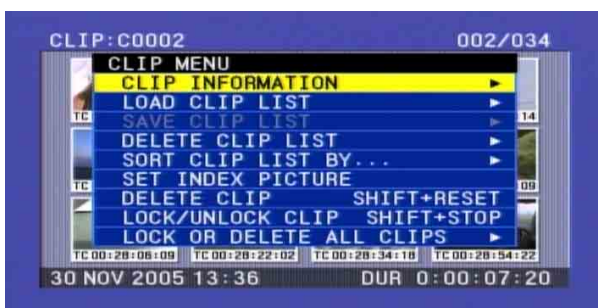

- 2 Use the SEL/SET button or MENU knob to select “CLIP INFORMATION”, and then press the button or knob.

A sub menu appears.

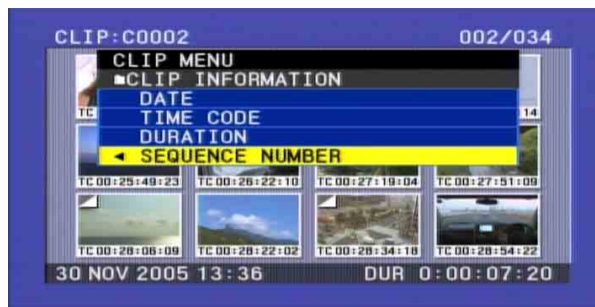

- 3 Use the SEL/SET button or the MENU knob to select the information to display from among the following, and then press the button or knob.

- **DATE:** Date of recording
- **TIME CODE:** Start timecode
- **DURATION:** Whole length of clip
- **SEQUENCE NUMBER:** Thumbnail sequence number

The information displayed on the lower side of thumbnails changes according to the item selected.

Example: When “SEQUENCE NUMBER” is selected



Thumbnail sequence number

Note

Some characters in clip names, clip list names, and titles may be converted to “□” characters for display in the thumbnail screen and CLIP menu. For details, see *page 72*.

Changing the Thumbnail Image (Index Frame) of a Clip

In the thumbnail screen, normally the first frame of a clip is displayed as the index frame.

To change this to show a different frame, proceed as follows.

Note

You can also select (at 1-second intervals) a frame within 10 seconds of the first frame as the thumbnail image of the clip at the time when you record a clip with this unit. For details, see *page 65*.

- 1 With the thumbnail screen displayed, hold down the SHIFT button and press the SEL/SET button to the bottom side (the CLIP MENU side).

The CLIP menu appears (see page 94).

- Use the SEL/SET button or MENU knob to select “SET INDEX PICTURE”, and then press the button/knob.

This switches to the screen for selecting a clip for changing the index frame.

- Select the desired thumbnail, and press the SEL/SET button or MENU knob.

The frame from the clip that is currently specified as the thumbnail is displayed. In this state, you can use playback or search.



- Using playback or search, find the new index frame. You can also turn the MENU knob for a jog operation.
- Press the SEL/SET button or MENU knob.

This sets the selected scene as the index frame, and returns to the thumbnail screen. When the thumbnail is other than the first frame, this is shown as follows.

Mark indicating that the thumbnail is not the first frame



Note

If you select a marked thumbnail, and press the SEL/SET button or MENU knob, this does not cue up to the thumbnail position. Cuing up is always to the first frame of the clip.

To cancel setting the index frame, hold down the SHIFT button and press the SEL/SET button down (CLIP MENU).

Cuing Up a Frame by Searching for an Essence Mark

Proceed as follows.

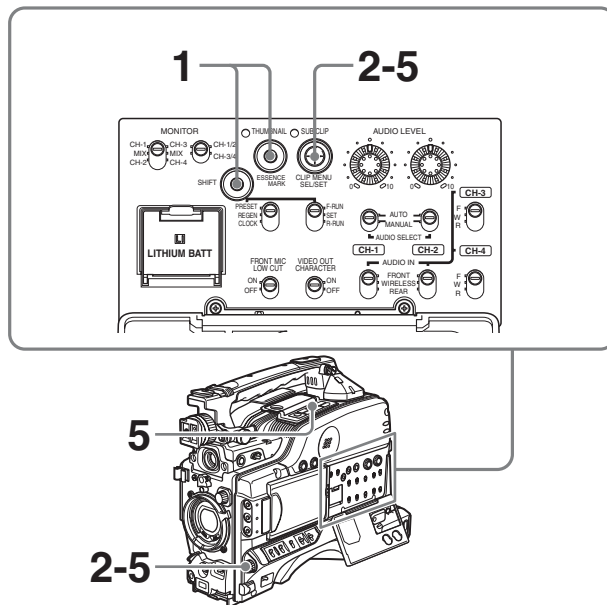

- With the SUB CLIP indicator off, hold down the SHIFT button and press the THUMBNAIL button.

The essence mark selection screen appears.



Essence marks not recorded on the disc appear in gray.

To escape from the essence mark selection screen to the previous screen

Press the RESET button on the right side of the LCD monitor.

- Use the SEL/SET button or the MENU knob to select the desired essence mark.
- Press the SEL/SET button or the MENU knob. Thumbnails of the frames including the selected essence mark appear.

(The example shows the case where SHOT MARK1 is selected as the essence mark.)

This indicates that the thumbnail images are the frames including the essence mark (SHOT MARK1). Sixth frame is selected from a total of 36 SHOT MARK1.

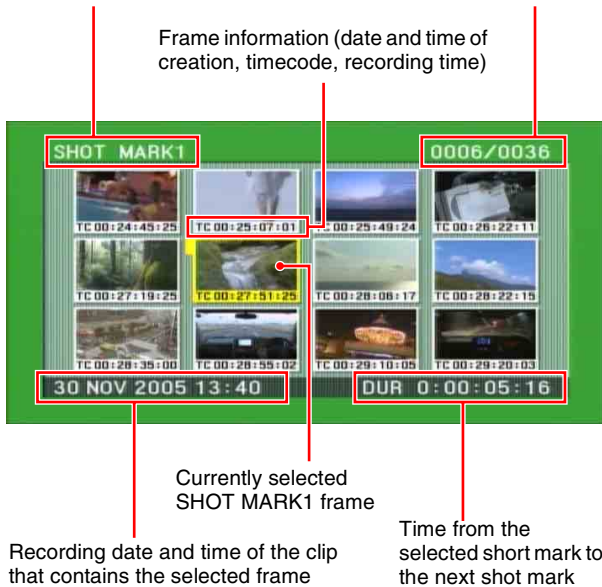

The “S1” and “S2” marks displayed on thumbnails indicate frames where SHOT MARK1 and SHOT MARK2 are set.

Thumbnails without one of these marks are frames where REC START essence marks are set.

For details of chapter settings, see “Recording Shot Marks” (page 65).

Deleting shot marks

You can delete a specified clip shot mark.

Notes

- Only SHOT MARK1 and SHOT MARK2 can be deleted. REC START cannot be deleted.
- Shot mark deletion is only possible when the settings are such that shot mark recording is possible.
- Essence marks cannot be deleted when the clip is locked (page 81).

1 In the chapter screen, hold down the SHIFT button and press the SEL/SET button down (CLIP MENU).

The CLIP menu appears (see page 94).

2 Select DELETE SHOT MARK.

3 Select the clip (SHOT MARK1 or SHOT MARK2).

By holding down the SHIFT button and turning the MENU knob, you can select more than one chapter.

4 Press the SEL/SET button or MENU knob.

A confirmation message appears.

5 Select “OK” and then press the SEL/SET button or MENU knob.

This deletes the specified shot mark.

Searching Using the Chapter Function

A thumbnail display shows the SHOT MARK1 and SHOT MARK2 recorded within the specified clip as chapter titles.

1 With the THUMBNAIL indicator and SUB CLIP indicator off, press the THUMBNAIL button.

2 Use the SEL/SET button (four-way arrow key) or MENU knob to select the desired clip.

An “S” mark appears at the upper right of the thumbnails of clips that have short marks set.



3 Press the COUNTER/CHAPTER button on the right side of the LCD monitor.

A chapter screen is displayed. The essence marks (REC START, SHOT MARK1, SHOT MARK2) recorded within the clip appear as thumbnails.

Searching Using the Expand Function

Using the expand function, you can divide the duration of a selected clip on the thumbnail screen into 12 segments,

and display a new thumbnail screen showing the first frame in each segment. This function allows rapid searching of the scenes within a particular clip. The expand function can be applied up to three times (12 divisions, 144 divisions, and 1728 divisions).

When FIND MODE on the ESSENCE MARK page of the MAINTENANCE menu is set to CLIP, this function operates in clip units. When FIND MODE is set to R.ST, it operates in REC START essence mark units (the range of a single recording operation).

Note

The maximum number of blocks may be larger than 1728 when the recorded duration of the clip is short. In this case, the frame interval of expanded thumbnails is fixed at 1 frame. This allows you to view expanded thumbnails at equal intervals.

- 1 With the THUMBNAIL indicator and SUB CLIP indicator off, press the THUMBNAIL button.
- 2 Use the SEL/SET button (four-way arrow key) or MENU knob to select the desired clip.
- 3 Press the DISPLAY/EXPAND button on the right side of the LCD monitor.

Thumbnails appear for twelve equal divisions of the clip.

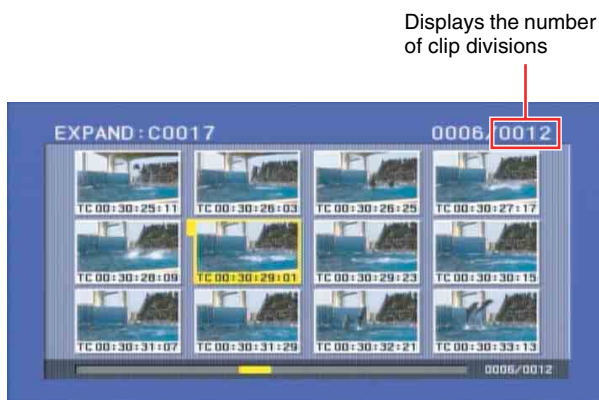

To change the expansion ratio

Each time you press the DISPLAY/EXPAND button changes the ratio in the sequence $\times 12 \rightarrow \times 144 \rightarrow \times 1728$. To change the ratio in the reverse sequence, hold down the SHIFT button and press the DISPLAY/EXPAND button. Alternatively, press the RESET button on the right side of the LCD monitor to return to the previous screen.

Clip List Playback

You can play back clips in their order in a clip list created with the scene selection function (see Chapter 4).

Playing back in clip list order

Proceed as follows.

- 1 If the clip list that you want to play exists on the disc, load it into the current clip list (see page 86).

For the clip list loading operation, see “Loading a Clip List from the Disc as the Current Clip List” on page 95.

- 2 With the THUMBNAIL indicator off, hold down the SHIFT button and press the SEL/SET button up (SUB CLIP).

The SUB CLIP indicator lights.

- 3 Press the PLAY/PAUSE button.

Playback begins from the first sub clip in the current clip list.

To return from clip list playback mode to normal playback mode

With Clip list playback stopped, hold down the SHIFT button and press the SET/SEL to the top side (the SUB CLIP side).

Note

Depending on the length of sub clips in the clip list and their arrangement on the disc, playback may freeze momentarily between sub clips.

Cuing up with sub clip thumbnails

With the desired clip list loaded in the current clip list, proceed as follows.

- 1 Press the THUMBNAIL button, lighting the THUMBNAIL indicator.
- 2 Hold down the SHIFT button, and press the SEL/SET button up (SUB CLIP).

The clip list display appears.

See page 87 for more information about the clip list screen.

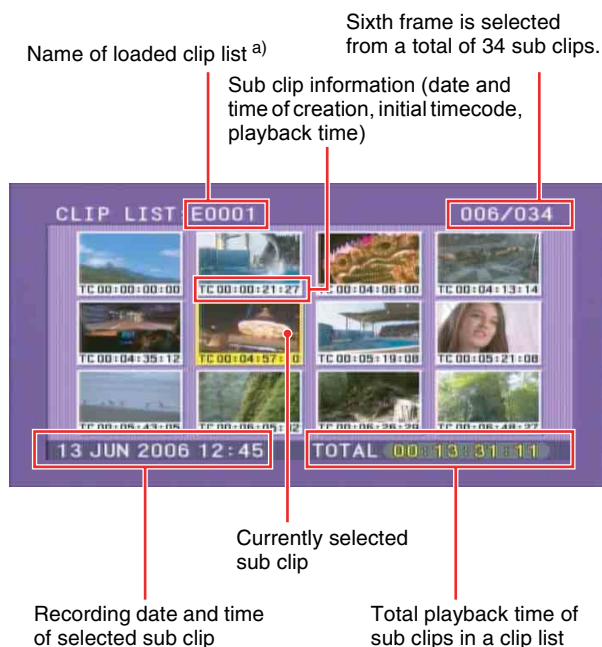

a) If the clip list has a title (page 69), the title is displayed enclosed in double quotation marks, for example "TITLE00001".

To escape from the clip list display to the whole-screen display

Press the THUMBNAIL button to turn the THUMBNAIL indicator off. This returns to the clip list playback state.

Note

Stop the unit before using the SUB CLIP button. Press the STOP button if the message "STOP ONCE!" appears.

- Use the SEL/SET button or MENU knob to select the sub clip you want to cue up.

- To cue up the selected clip, press the SEL/SET button or MENU knob.

To start playback from the selected clip, press the PLAY/PAUSE button.

Note

The clip list thumbnail screen always shows the first frame (In point) of each sub clip.

Locking (Write-Protecting) Clips

In the thumbnail screen, you can lock them so that they cannot be deleted or altered.

Locking prevents the following operations on clips.

- Deletion
- Renaming by FAM or FTP
- Changing the thumbnail image (index picture)

- Adding and deleting shot marks

Notes

- Locked clips are deleted along with other clips.
- Clips cannot be locked or unlocked when the Write Inhibit tab of the disc is set to the recording disabled position.

- With the SUB CLIP indicator off, press the THUMBNAIL button, lighting the THUMBNAIL indicator.

The thumbnails of the clips on the disc appear.

- Select the clip to lock (you can do this with the same operations as step 2 of "Searching Using Thumbnails" (page 76)).



- Hold down the SHIFT button and press the CLIP MENU button.

Then CLIP menu appears.

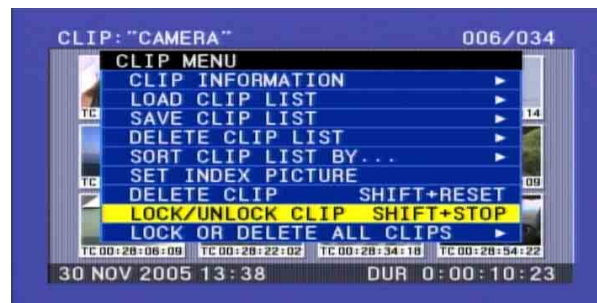

- Use the SEL/SET button or MENU knob to select "LOCK/UNLOCK CLIP", and then press the button or knob.

A lock confirmation screen appears. This screen displays clip names and clip titles.

To cancel the lock operation and return to the thumbnail screen

Use the SEL/SET button or MENU knob to select "CANCEL", and then press the button or knob.

Alternatively, press the RESET button on the right side of the LCD monitor.

- With “OK” selected, press the SEL/SET button or MENU knob.

You return to the thumbnail screen, and a lock icon appears on the thumbnail of the selected clip to show that it is locked.



You cannot delete locked clips, rename them, set their thumbnails, and so on. Unlock the clip if you want to perform any of these operations.

To lock clips with a shortcut operation

You can lock clips without using the CLIP menu. After carrying out step 2 in the procedure, press the STOP button with the SHIFT button held down (shortcut operation).

To unlock clips

Carry out step 2 of “Locking (Write-Protecting) Clips” to select a locked clip (one with the lock icon displayed on its thumbnail). Then do one of the following.

- Carry out steps 3 and 4 of “Locking (Write-Protecting) Clips.”
- Press the STOP button with the SHIFT button held down (shortcut operation).

To lock all clips

- Carry out steps 1 and 3 of “Locking (Write-Protecting) Clips” to display the CLIP menu.
- Use the SEL/SET button or MENU knob to select “LOCK OR DELETE ALL CLIPS”, and then press the button or knob.
A submenu screen appears.
- Select “LOCK ALL CLIPS”, and then press the SEL/SET button or MENU knob.
A confirmation screen appears.
- With “OK” selected, press the SEL/SET button or MENU knob.
All clips are locked.

To unlock all clips

Carry out the procedure in “To lock all clips”, selecting “UNLOCK ALL CLIPS” in step 3.

Deleting Clips

You can delete clips while checking their contents.

Notes

- Clips cannot be deleted when the Write Inhibit tab of the disc is set to the recording disabled position.
- Locked clips cannot be deleted.
- If the deletion target clip is referenced by clip lists on the disc, all of those clip lists are deleted as well.
- If the deletion target clip is referenced in the current clip list, all of the referenced sub clips, and only those sub clips, are deleted at the same time as the deletion target clip.
- You can use the DISC page of the OPERATION menu to delete the last clip or all clips. *For details, see page 64.*

- With the SUB CLIP indicator off, press the THUMBNAIL button, turning it on.

The thumbnails of the clips on the disc appear.

- Select the clip to delete (you can do this with the same operations as step 2 of “Searching Using Thumbnails” (page 76)).



- Press the CLIP MENU button with the SHIFT button held down.

The CLIP menu appears (see page 94).

- Use the SEL/SET button or MENU knob to select “DELETE CLIP”, and then press the button or knob.

A deletion confirmation screen appears and then thumbnails of four frames (the first frame, intermediate frame 1, intermediate frame 2, and the last frame) in the target clip appear. At the same time, the clip name, title, date and time of creation, and duration appear.

One of the following messages appears, depending on whether the target clip is referenced in a clip list.

- When the target clip is not referenced in a clip list: “DELETE CLIP?”

- When the target clip is referenced in a clip list: “DELETE CLIP & CLIP LIST?” (All clip lists that reference the deletion target clip will be deleted as well).

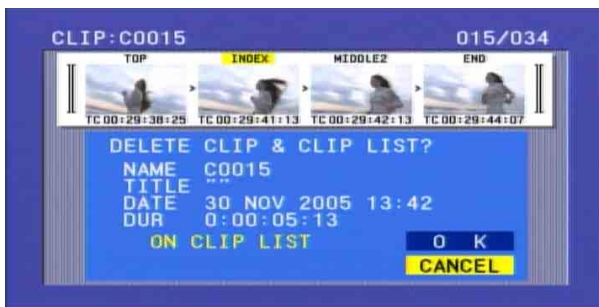

To cancel the deletion and return to the thumbnail screen

Use the SEL/SET button or MENU knob to select “CANCEL”, and then press the button or knob. Alternatively, press the RESET button on the right side of the LCD monitor.

- 5 Use the SEL/SET button or MENU knob to select “OK”, and then press the button or knob.

The clip is deleted and you return to the thumbnail screen.

To delete clips with a simple operation

The clip deletion screen appears directly, you can delete clips without displaying the CLIP menu.

After step 2, press the RESET button on the right side of the LCD monitor with the SHIFT button held down (shortcut operation).

To delete all clips

- 1 Carry out steps 1 and 3 of “Locking (Write-Protecting) Clips” to display the CLIP menu.
- 2 Use the SEL/SET button or MENU knob to select “LOCK OR DELETE ALL CLIPS”, and then press the button or knob.

A sub menu appears.

- 3 Use the SEL/SET button or MENU knob to select “DELETE ALL CLIPS”, and then press the button or knob.

A deletion confirmation screen appears.

- 4 To execute the deletion, use the SEL/SET button or MENU knob to select “OK”, and then press the button or knob.

All clips are deleted.

Notes

- Locked clips cannot be deleted.
- When all clips have been deleted, you return to the normal screen.

Overview

What is scene selection?

Scene selection is a function which allows you to select material (clips) from the material recorded on a disc and perform cut editing. You can do this by operating on this unit only.

- Scene selection is a convenient way to perform cut editing in the field and in other offline situations.
- In scene selection you create a clip list (editing data). Since the material itself is not affected, you can repeat this any number of times.
- You can play back the edit list created by scene selection on this unit.
- In the scene selection function, you can add whole clips, add parts of a clip, add using chapters, change the playback sequence, amend or delete In and Out points, and carry out all of these operations simply on this unit.
- Clip lists (edit data) created with the scene selection function can be used on XPRI and other full-feature nonlinear editing systems.

Flow of scene selection editing

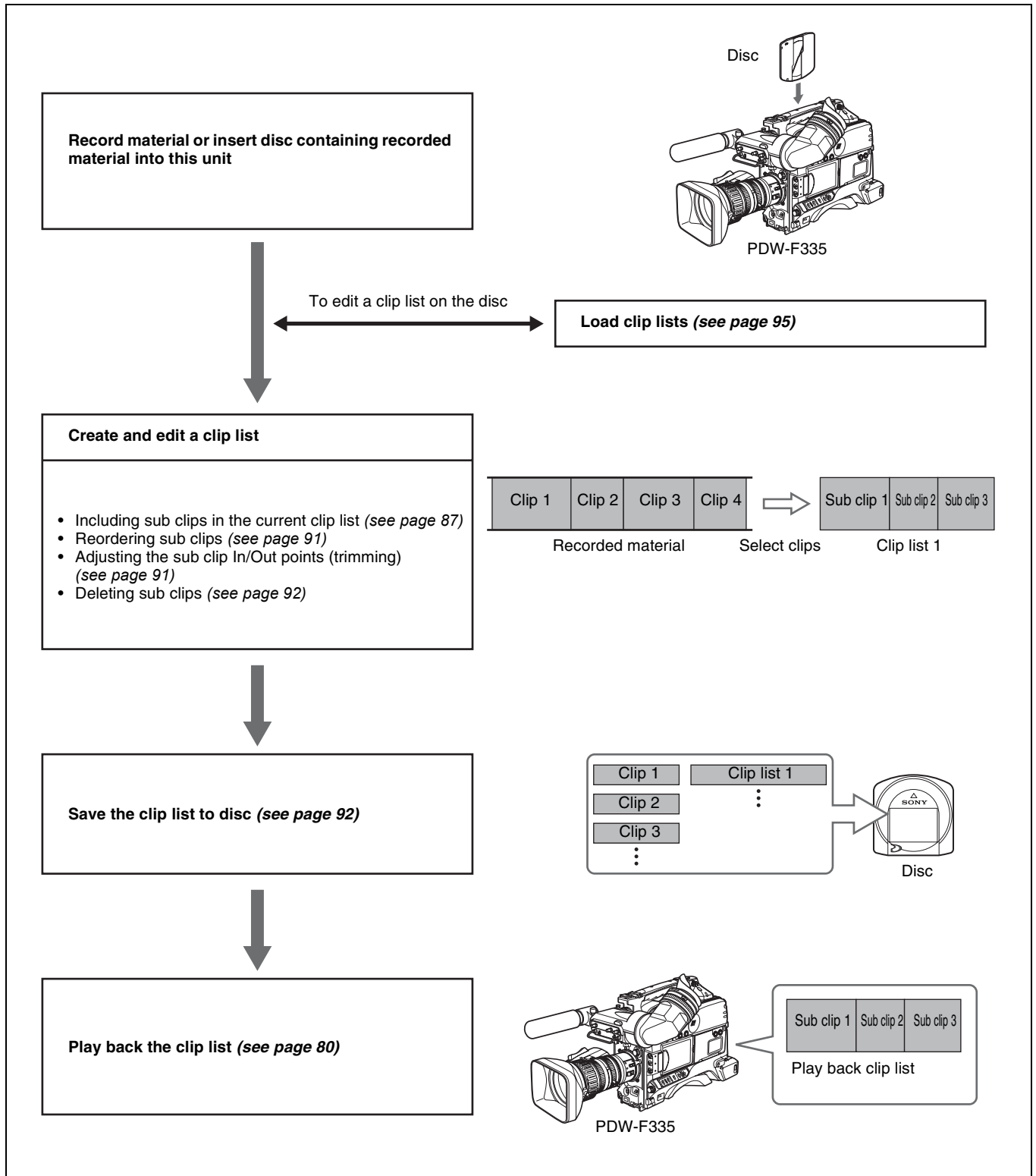

Clip

Material recorded with this unit is managed in units called “clips”. A clip contains the material between a recording start point and a recording end point. Clips have numbers beginning with C, for example C0001.

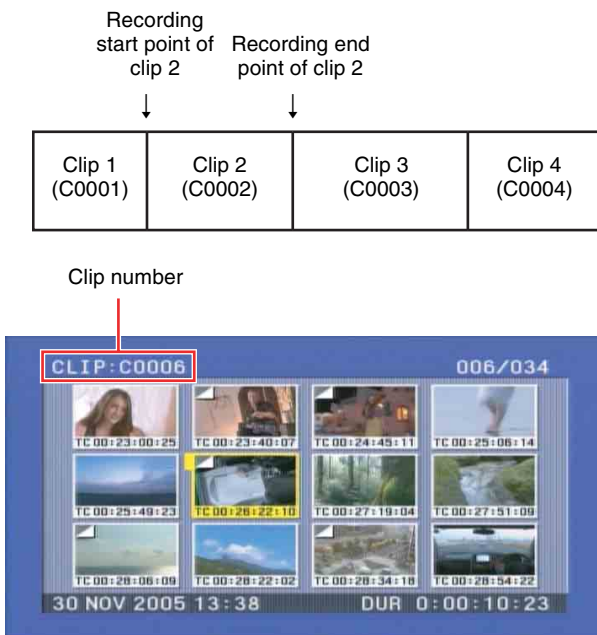

Instead of using clip numbers, you can manage clips by assigning clip titles or names. For details, see “To assign user-defined titles automatically when clips are recorded” on page 70 and “Assigning User-Defined Clip and Clip List Name” on page 71.

Clip list

You can use the scene selection function to select desired clips from the clips saved on a disc and create a cut edit list called a “clip list”.

Clip lists have numbers beginning with E, for example E0001. Up to 99 clip lists can be saved on a disc.



Thumbnails of selected clip list

Sub clips (clips in clip lists)

The specified clips (or parts of clips) in a clip list are called “sub clips”. Sub clips are virtual edit lists specifying ranges in the original clips. Clip data in the original clips is not overwritten.

The following figure illustrates the relation between clips and sub clips.

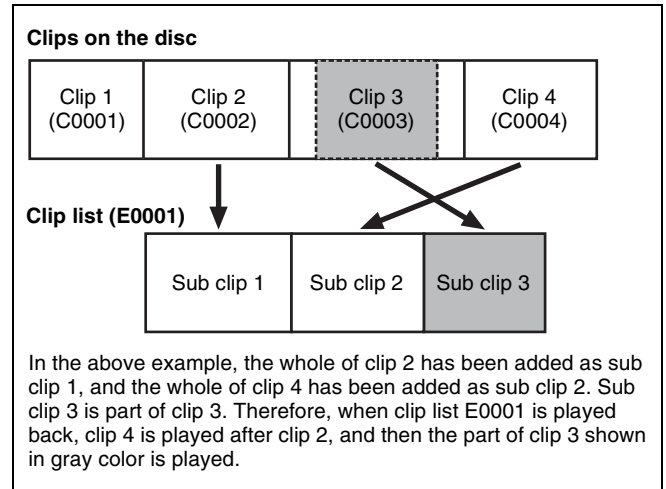

Clip list editing (current clip list)

To edit a clip list, you need to load the clip list from the disc into the internal unit memory.

The clip list which is currently loaded into the unit memory is called the “current clip list”.

The current clip list is always the target of sub clip creation and editing. Clip list playback also uses the current clip list.

After creating and editing a clip list, you need to save it to disc.

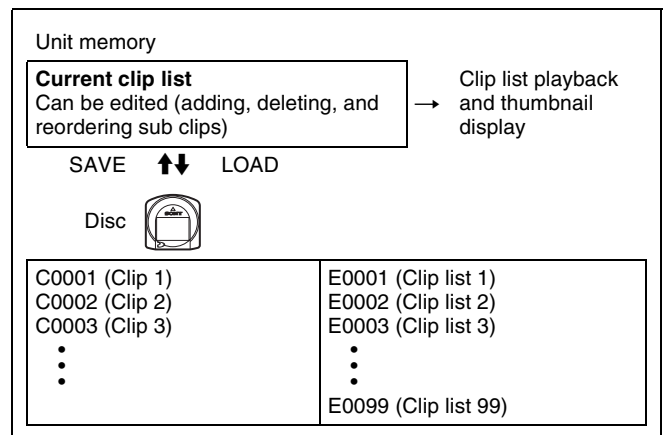

Clip list playback

Clips and clip lists are saved together on a disc. Clips are played back according to clip list data.

Creating Clip Lists

Including Sub Clips in the Current Clip List

Select the desired clip in the thumbnail screen, to include it in the clip list as a sub clip.

Note

The CLIP menu handles up to 99 clip lists.

Including a clip selected in the thumbnail screen in the clip list

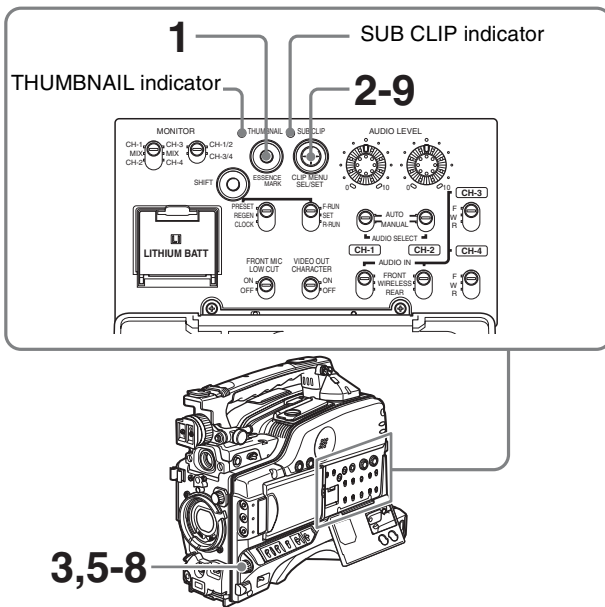

Proceed as follows.

- 1 With the SUB CLIP indicator off, press the THUMBNAIL button to turn the THUMBNAIL indicator on.

If the menu screen is displayed, move the MENU switch to the OFF position and press the THUMBNAIL button.

If you move the MENU switch to ON while thumbnails are displayed, the thumbnail display disappears, and the menu appears.

The thumbnails of the clips on the disc appear. (In the following description, this is referred to as the “thumbnail screen”.)



- 2 Hold down the SHIFT button, and press the SEL/SET button up (SUB CLIP).

The “LOAD CLIP LIST” screen of the CLIP menu appears.

For an already created clip list, the details including the creation date appear, and for an empty clip list, “NEW FILE” appears.

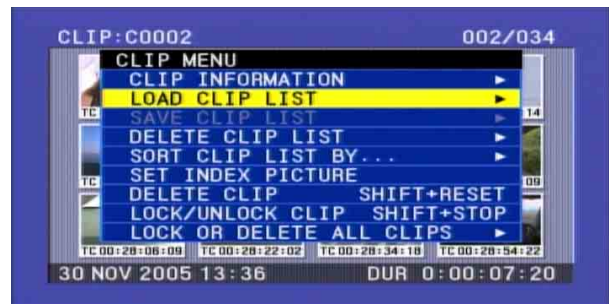

(If a clip list is already loaded, the LOAD CLIP LIST screen does not appear. In this case proceed to step 4.)

Displays the type of the information

Switch the displayed information by pressing the SEL/SET button to the right side

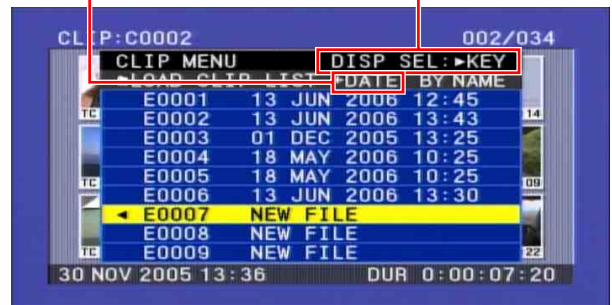

To switch the information displayed in clip lists

Press the SEL/SET button to the right side.

Each press of the button switches the information displayed in the following order.

Date and time of creation → title → clip name → Date and time of creation....

The following information is displayed for each type.

+DATE: Date and time of clip list creation or last modification

+TITLE: The title of the clip list, if it has one

+NAME: The standard or user-defined name of the clip list

You can also use the supplied PDZ-1 Proxy Browsing Software to set clip list titles.

- Use the SEL/SET button or MENU knob to select a clip list number (E0001 and so on), and press the button or knob.

You can also move the cursor with the PREV and NEXT buttons.

When you have a large number of clip lists, you can use the following operations to move the cursor closer to the clip list that you want.

With the SHIFT button held down, press the PREV or NEXT button: Move to the first or last clip list.

Press the F REV or F FWD button: Move to previous or next page.

If you select a clip list number with a “NEW FILE”, an empty clip list is displayed as shown in the following figure.

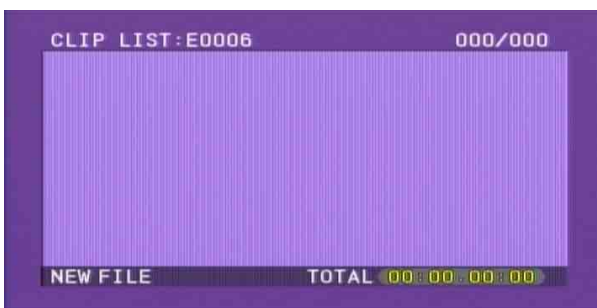

- Hold down the SHIFT button, and press the SEL/SET button down (CLIP MENU).

The CLIP menu appears.

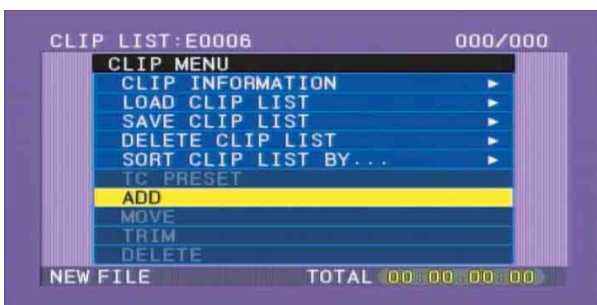

- Use the SEL/SET button or MENU knob to select “ADD”, then press the button or knob.

A screen as shown below appears.

(In the following description, this whole screen is referred to as the “scene selection screen”.)



To return to the CLIP menu

Press the RESET button on the right side of the LCD monitor.

- Use the SEL/SET button (four-way arrow key) or MENU knob to select the clip you want to include in the clip list, press the button or knob. To make a multiple selection, hold down the SHIFT button, and turn the MENU knob.

An I-bar cursor appears in a window in the lower part of the screen to show the insertion position.

If you press the RESET button at this point, you return to the state at the beginning of step 6.

- Press the SEL/SET button or MENU knob.

The clip selected in the upper part is added to the current clip list in the lower part, as a sub clip. The screen returns to the CLIP menu (*see step 4*).

To continue working without returning to the CLIP menu

With the SHIFT button held down, press the SEL/SET button or the MENU knob.

You return directly to the scene selection screen of step 5.

- Repeat steps 5 to 7 until all desired clips have been added to the current clip list.

You can add the same clip as a sub clip any number of times.

Total duration of sub clips in the current clip list



I-bar cursor (shows insertion position of next sub clip)

Thumbnails of the sub clips already added to the current clip list

- 9** Add all the desired clips to the current clip list, and press the RESET button on the right of the LCD monitor.

You return to the clip list screen, which displays thumbnails of the newly added clips (added as sub clips).



- 10** Save the contents of the current clip list on the disc.

See “Saving the Current Clip List to Disc” on page 92.

Notes

- If the contents of the current clip list is not saved to disc, then ejecting the disc, or powering off will destroy the data. After creating a clip list, be sure to save it to disc.
- An asterisk (*) appears after the date and time of creation when a clip list has not been saved to disc.

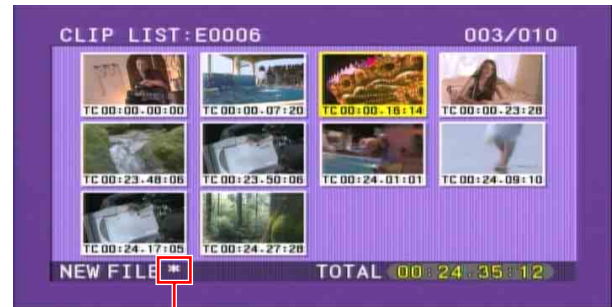

Asterisk appears when clip list has not been saved to disc.

- Even when clips whose thumbnail image (index frame) is not the first frame are added to a clip list, it is always the first frame that is displayed on the clip list screen.

Mark indicating that the thumbnail is not the first frame



Adding Sub Clips Using the Expand Function

You can use the expand function (*see page 79*) to divide a sub clip and display thumbnails of the divisions. This allows you to include a section of the sub clip. Proceed as follows.

- 1** In the upper part of the scene selection screen, select the sub clip for expanded display.
- 2** Press the DISPLAY/EXPAND button on the right of the LCD monitor.

The upper part of the screen shows thumbnails for the clip in eight divisions.



To vary the expansion ratio

Each time you press the DISPLAY/EXPAND button changes the ratio through the sequence $\times 8 \rightarrow \times 64 \rightarrow \times 512$.

To return to the previous setting, hold down the SHIFT button and press the DISPLAY/EXPAND button to step back one level.

Note

The maximum number of divisions may be 512 or greater when you expand clips with short recording times. In this case, the interval between the expanded thumbnail frames is fixed at 1 frame, which allows you to view expanded thumbnails at a constant interval.

- Use the SEL/SET button or MENU knob to select the thumbnail for the part you want to include in the clip list. To select two or more thumbnails, hold down the SHIFT button and operate the MENU knob.

Note

Even if more than one thumbnail is selected, the addition to the current clip list is linked to a single sub clip.

- Press the SEL/SET button or MENU knob.

The clip selected in the upper part is added to the current clip list in the lower part, as a sub clip. The section from the selected thumbnail to the next thumbnail is included as a sub clip.

Adding Sub Clips Using the Chapter Function

You can use the chapter function (*see page 79*) to display thumbnails of shot marks in clips on the disc, and include sections of those clips in clip lists.

Proceed as follows.

- In the scene selection screen, select the clip for chapter display.

An “S” mark appears in the upper right of clips where shot marks are set.

- Press the COUNTER/CHAPTER button on the right of the LCD monitor.

Thumbnails of the chapters in the specified clip appear in the upper part of the scene selection screen.

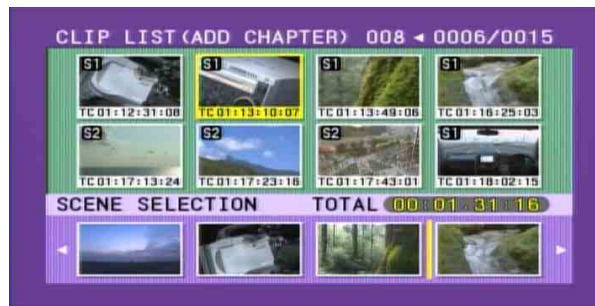

- Using the SEL/SET button or MENU knob, from the positions of the essence marks recorded within this clip, select the chapter for the part you want to include in the clip list. To select two or more chapters, hold down the SHIFT button and operate the MENU knob.

The section from the selected thumbnail to the next thumbnail is included as a sub clip.

Note

Even if more than one chapter is selected, the addition to the current clip list is linked to a single sub clip.

- Press the SEL/SET button or MENU knob.

The clip selected in the upper part is added to the current clip list in the lower part, as a sub clip.

Editing Clip Lists

Reordering Sub Clips

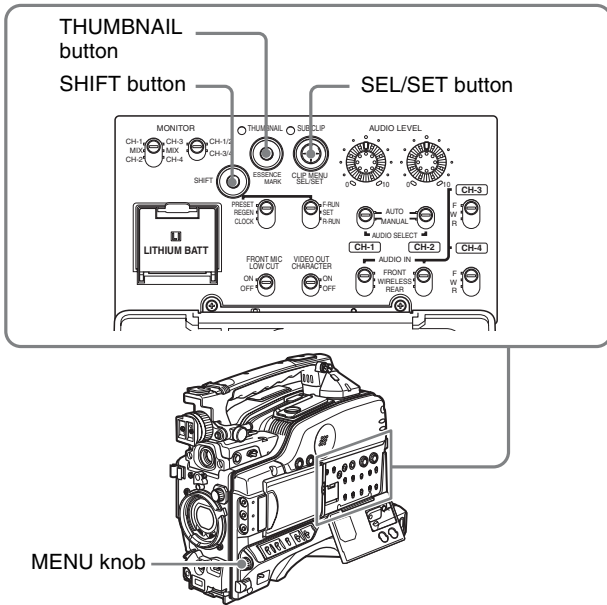

Proceed as follows.

- 1 In the clip list screen, hold down the SHIFT button, and press the SEL/SET button down (CLIP MENU).

The CLIP menu appears.

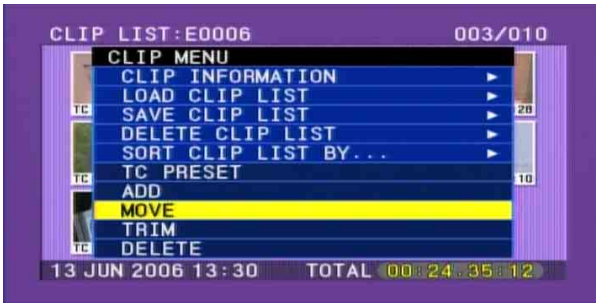

- 2 Use the SEL/SET button or MENU knob to select "MOVE", and press the button or knob.

This shifts to the MOVE screen.

- 3 Use the SEL/SET button (four-way arrow key) or MENU knob to select the sub clip that you want to move, and then press the button or knob.

To make a multiple selection, hold down the SHIFT button, and turn the MENU knob.

An I-bar cursor appears, indicating the movement destination.

Indicates that 2nd sub clip will be moved to position of 7th sub clip.



Cursor showing position to which selected sub clip will be moved.

- 4 Use the SEL/SET button or MENU knob to move the I-bar cursor to the position to which you want to move, and press the button or knob.

This changes the sequence of sub clips.



To continue moving sub clips

If you hold the SHIFT down when you press the SEL/SET button or MENU knob, you return to step 3 instead of the CLIP menu after a clip is moved. This allows you to continue moving sub clips

- 5 Save the contents of the current clip list to disc.

See "Saving the Current Clip List to Disc" on page 92.

Adjusting Sub Clip In/Out Points (Trimming)

Proceed as follows.

- 1 Carry out step 1 of the procedure in "Reordering Sub Clips" on page 91, to display the CLIP menu.

- 2 Use the SEL/SET button or MENU knob to select "TRIM", and press the button or knob.

This switches to the screen for selecting a thumbnail for trimming.

- Use the SEL/SET button (four-way arrow key) or MENU knob to select the desired sub clip, and press the button or knob.

The first frame of the selected sub clip is displayed. In this state you can play back or search the entire disc.



- Carry out playback or search, to find the scene to be the new In point or Out point of the selected sub clip. You can also turn the MENU knob for a jog operation.

- Use the SEL/SET button or MENU knob to select “IN” or “OUT” on the screen, and press the button or knob.

The set timecode value appears as “IN” or “OUT”.

To reset an In point or Out point

Select “IN” or “OUT” on the screen and then press the RESET button on the right side of the LCD monitor. The In or Out point returns to the value it had before you entered the trim screen.

To cue up the In or Out point

(Do one of the following to cue up the In point.)

- With the SHIFT button held down, press the PREV button.
- With the SEL/SET button pressed to the left, press the PREV or NEXT button.

(Do one of the following to cue up the Out point.)

- With the SHIFT button held down, press the NEXT button.
- With the SEL/SET button pressed to the right, press the PREV or NEXT button.

- When you are finished setting the In or Out point, select “OK”.

The background of “OK” turns to yellow.

- Press the SEL/SET button or MENU knob.

The trim is executed.

To continue trimming sub clips

With the SHIFT button held down, press the SEL/SET button or the MENU knob. After the trim is executed, you return to the screen of step 3 instead of the CLIP menu. This allows you to continue trimming.

To cancel the trim

With the SHIFT button held down, press the SEL/SET button to the lower side (CLIP MENU side).

- Save the contents of the current clip list to disc.

See “Saving the Current Clip List to Disc” on page 92.

Deleting Sub Clips

Proceed as follows.

- Carry out step 1 of the procedure in “Editing Clip Lists” on page 91, to display the CLIP menu.

- Use the SEL/SET button or MENU knob to select “DELETE”, and press the button or knob.

This switches to the screen for selecting a sub clip to be deleted.

- Use the SEL/SET button (four-way arrow key) or MENU knob to select the sub clip to be deleted, and press the button or knob. To make a multiple selection, hold down the SHIFT button, and turn the MENU knob.

A confirmation message appears.

- Select “OK”, and press the button or knob.

This carries out the deletion.

To continue deleting sub clips

With the SHIFT button held down, press the SEL/SET button or the MENU knob. After the deletion is executed, you return to the screen of step 3 instead of the CLIP menu. This allows you to continue deleting.

- Save the contents of the current clip list to disc.

Saving the Current Clip List to Disc

Proceed as follows.

- Display the CLIP menu.

See “To display the CLIP menu” on page 94.

- Use the SEL/SET button or MENU knob to select “SAVE CLIP LIST” with the cursor in the CLIP menu, and press the button or knob.

This displays the list of clip lists.

For a clip list in which no data has been stored, this appears as “NEW FILE”.

To switch the information displayed for clip lists

Press the SEL/SET button to the right side.

Each press switches the information displayed for clip lists in the following order.

Date and time of creation → Title → Clip list name → Date and time of creation → ...

- 3 Select the desired clip list name, and press the button/knob.

This saves the current clip list to disc.

To apply a desired title or name to a clip list

Use the supplied PDZ-1 Proxy Browsing Software.

For details, see the PDZ-1 online help.

Setting the Start Timecode for the Current Clip List

By default, the start timecode (LTC) for the current clip list is set to 00:00:00:00.

To set this to a different value, proceed as follows.

- 1 Display the CLIP menu.
See “To display the CLIP menu” on page 94.
- 2 Use the SEL/SET button or MENU knob to align the cursor with “TC PRESET”, and press the button or knob.

The display appears as in the following figure.



The timecode shown is the start timecode currently set for the current clip list.

- 3 Press the SEL/SET button left and right to select the desired time unit (any of HOUR, MIN, SEC, and FRAME).
- 4 Press the SEL/SET button up or down, or turn the MENU knob to display the desired value.
- 5 When all time units are set correctly, press the SEL/SET button or MENU knob.

This sets the start timecode for the current clip list, which will be used for playback.
To cancel the timecode setting, hold down the SHIFT

button, and press the SEL/SET button down (CLIP MENU).

Alternatively, press the RESET button on the right side of the LCD monitor.

- 6 Save the current clip list.

See “Saving the Current Clip List to Disc” on page 92.

Note

The DF/NDF timecode setting of the current clip list is set to the current setting of the camcorder when one of the following operations is performed.

- When you add the first sub clip
- When you set the start timecode

See page 119 for more information about DF/NDF settings.

Switching the Information Displayed on Thumbnails

You can switch the information displayed at the bottom of thumbnails in the thumbnail screen. You can also select display of sequence numbers.

Proceed as follows.

- 1 Display the CLIP menu.
See “To display the CLIP menu” on page 94.
- 2 Select “CLIP INFORMATION”.

A sub menu appears.

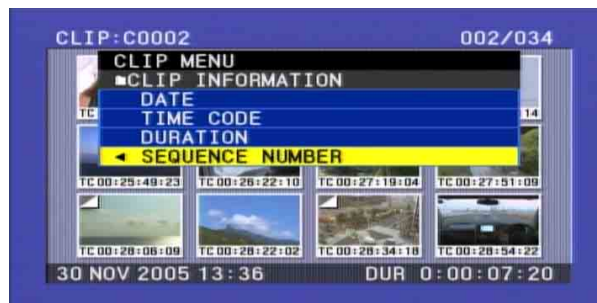

- 3 Use the SEL/SET button or MENU knob to select the information to display from among the following, and then press the button or knob.

DATE: Date of recording

TIME CODE: Start timecode

DURATION: Whole length of clip

SEQUENCE NUMBER: Thumbnail sequence number

The factory default setting is “TIME CODE”.
The display below each thumbnail changes depending on the item selected.

See “Switching the Information Displayed in the Thumbnail Screen” (page 77) for more information about SEQUENCE NUMBER.

Managing Clip Lists

Using the CLIP menu, you can save created clip lists to disc, read them from the disc into this unit, and delete them from the disc.

To display the CLIP menu

In the thumbnail or clip list screen, hold down the SHIFT button and press the SEL/SET button down (CLIP MENU).

Note

The CLIP menu handles up to 99 clip lists.

The following table lists the CLIP menu items, each of which is displayed or not on the menu screen depending on the operating state of the unit.

| Item | Function |
|--|--|
| CLIP INFORMATION | Select the information to be displayed below the thumbnails (See pages 77 and 93) |
| LOAD CLIP LIST | Load a clip list from the disc as the current clip list (see page 95) |
| SAVE CLIP LIST | Save the current clip list to the disc(see page 92) |
| DELETE CLIP LIST | Delete a clip list from the disc (see page 95) |
| SORT CLIP LISTS BY... | You can sort the list of clip lists by name or date and time of creation (see page 95) |
| SET INDEX PICTURE ^{a)} | Change the thumbnail image of a clip (see page 77) |
| DELETE CLIP ^{a)} | Delete a clip (see page 82) |
| LOCK/UNLOCK CLIP | Lock or unlock a clip (see page 81) |
| LOCK OR DELETE ALL CLIPS ^{a)} | Lock/unlock or delete all clips (see pages 81 and 82) |
| TC PRESET ^{b)} | Change the start timecode for the current clip list to a desired value (see page 93) |
| ADD ^{b)} | Add sub clips to the current clip list (see page 87) |
| MOVE ^{b)} | Reorder sub clips (see page 91) |
| TRIM ^{b)} | Change the In point or Out point of a sub clip (see page 91) |
| DELETE ^{b)} | Delete unnecessary sub clips (see page 92) |
| DELETE SHOT MARK ^{c)} | Delete a shot mark (see page 79) |

a) Displayed only in operating the thumbnail screen

- b) Displayed only in operating the clip list screen
- c) Displayed only in operating the chapter screen

To exit the CLIP menu

Carry out the same operation as when displaying the menu (hold down the SHIFT button, and press the SEL/SET button down (CLIP MENU)).

Loading a Clip List from the Disc as the Current Clip List

Proceed as follows.

- 1 Display the CLIP menu.

See “To display the CLIP menu” on page 94.

- 2 Select “LOAD CLIP LIST”.

This displays the clip lists.

To switch the information displayed for clip lists

Press the SEL/SET button to the right side.

Each press switches the information displayed for clip lists in the following order.

Date and time of creation → Title → Clip list name
→ Date and time of creation → ...

- 3 Select the desired clip list, and press the SEL/SET button or MENU knob.

This loads the selected clip list as the current clip list.

To display thumbnails of the read-in current clip list

- 1 Press the THUMBNAIL button to turn the THUMBNAIL indicator on.

If the menu screen is displayed, move the MENU switch to the OFF position and press the THUMBNAIL button.

If you move the MENU switch to ON while thumbnails are displayed, the thumbnail display disappears, and the menu appears.

- 2 Hold down the SHIFT button and press the SEL/SET button up to turn the SUB CLIP indicator on.

This displays thumbnails of the sub clips within the clip list.

Deleting a Clip List from the Disc

Proceed as follows.

- 1 Display the CLIP menu.

See “To display the CLIP menu” on page 94.

- 2 Select “DELETE CLIP LIST”.

This displays the clip lists.

To switch the information displayed for clip lists

Press the SEL/SET button to the right side.

Each press switches the information displayed for clip lists in the following order.

Date and time of creation → Title → Clip list name
→ Date and time of creation → ...

- 3 Select the clip list you want to delete, and press the SEL/SET button or MENU knob.

A confirmation message appears.

- 4 Select “OK”, and press the SEL/SET button or MENU knob.

This deletes the selected clip list from the disc.

To continue deleting other clip lists

After selecting “OK”, press the SEL/SET button while holding down the SHIFT button. The selected clip list is deleted, and you return to step 3 and can continue deleting clip lists.

Sorting the List of Clip Lists

You can sort the list of clips lists that appears when you select LOAD CLIP LIST and similar commands. Existing clip lists can be sorted in order of name or in order of date and time of creation.

Proceed as follows.

- 1 Display the CLIP menu.

See “To display the CLIP menu” (page 94).

- 2 Use the SEL/SET button or MENU knob to select “SORT CLIP LISTS BY...”, and then press the button or knob.

A screen like the one shown below appears.

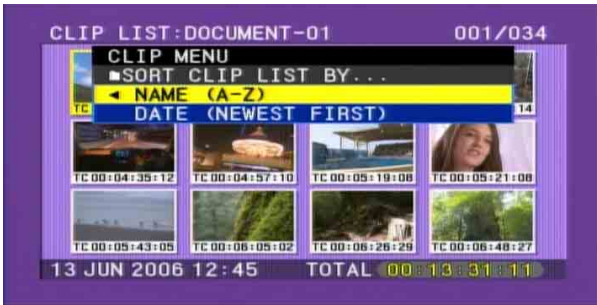

Note

Some characters in clip names, clip list names, and titles may be converted to “□” characters for display in the thumbnail screen and CLIP menu. *For details, see page 71.*

- Use the SEL/SET button or MENU knob to select “NAME” or “DATE”, and then press the button or knob.

NAME: Sort in ascending order by clip list name.

DATE: Sort by date of creation, with the newest clip list first.

In the LOAD CLIP LIST and similar screens, the list of existing clip lists is sorted by the method you chose in step 3.

Unused clip lists are excluded from the sort.

If you selected “NAME”

BY NAME: Sort by name.



If you selected “DATE”

BY DATE: Sort by date.



Using the PDZ-1 Proxy Browsing Software

When a computer with the PDZ-1 Proxy Browsing Software installed is connected to this unit, you can transfer the proxy AV data and metadata files recorded on a disc to the computer. On the computer side, PDZ-1 enables you to browse the proxy AV data, add or modify metadata (titles, comments, essence marks, etc.), or create a clip list.

The modified metadata and the created clip list can then be written back to the disc loaded in this unit.

System requirements to use the PDZ-1

The following are required to use the PDZ-1.

- Computer:
 - PC with Intel Pentium M CPU, at least 1 GHz (installed memory: at least 512 MB)
- Operating system: Microsoft Windows XP Professional SP2 or higher, Windows Vista Ultimate/Business (32bit), or Mac OS X v10.4.11 or higher
- Web browser: Internet Explorer 6.0 SP1 or higher
- DirectX: DirectX 8.1b or higher

To install the PDZ-1

Insert the supplied CD-ROM (XDCAM Application) into the CD-ROM drive of your computer, and run the installer in the PDZ-1 directory.

For details, refer to the ReadMe file in the CD-ROM.

Note

Make sure that the hard disk drive on which the work folder to store the material transferred from this unit has adequate free space.

The amount of proxy AV data transferred is up to a maximum of 2.8 GB per disc (LP format).

Menu Organization and Operation

The following chart shows the organization of menus in this camcorder.

Note that the USER menu organization shown in the chart is as registered at the factory.

For details about USER MENU CUSTOMIZE, see “Editing the USER Menu” on page 132.

| Menu selection | 1st level | 2nd level | 3rd level |
|----------------|-------------|-----------------|---|
| TOP MENU | USER | PAINT | <ul style="list-style-type: none"> — A.IRIS — DETAIL LEVEL — MASTER BLACK — GAMMA SELECT — MASTER GAMMA — BLACK GAMMA — PRESET MATRIX SEL |
| | | SCENE FILE | <ul style="list-style-type: none"> — 1-5 — STANDARD — SCENE RECALL — SCENE STORE — F.ID |
| | | FORMAT | <ul style="list-style-type: none"> — SYSTEM — REC FORMAT — BIT RATE (HD) — AUDIO CH (HD) — ASPECT RATIO (DV) — COUNTRY |
| | | SPECIAL EFFECTS | <ul style="list-style-type: none"> — CLIP CONT.REC — INTERVAL REC — INTERVAL TIME — NUMBER OF FRAME — NUMBER OF TIMES — PRE-LIGHTING — PICTURE CACHE — CACHE REC TIME |
| | | ASSIGNABLE | <ul style="list-style-type: none"> — ASSIGN SW <1> — ASSIGN SW <2> — ASSIGN SW <3> — ASSIGN SW <4> |
| | | DISC | <ul style="list-style-type: none"> — DELETE LAST CLIP — DELETE ALL CLIPS — QUICK FORMAT |
| | | OUTPUT | <ul style="list-style-type: none"> — COMPONENT OUT — HD→SD (PLAYBACK) — i.LINK MODE |
| | | VF SETTING | <ul style="list-style-type: none"> — ZEBRA — ZEBRA SELECT — ZEBRA1 DET.LEVEL — PEAKING VOL.LINK — H DETAIL LEVEL — V DETAIL LEVEL — DETAIL FREQ — VF ASPECT |
| | (Continued) | (Continued) | |



| Menu selection | 1st level | 2nd level | 3rd level |
|----------------|---------------------|-----------------|---|
| | | MARKER | <ul style="list-style-type: none"> MARKER CENTER SAFETY ZONE SAFETY AREA ASPECT ASPECT SELECT |
| | | SKIN DETAIL | <ul style="list-style-type: none"> SKIN DETAIL SKIN DETAIL LVL SKIN DETECT SKIN AREA IND. SKIN DTL SAT SKIN DTL HUE SKIN DTL WIDTH |
| | | RESET | ALL PRESET |
| | USER MENU CUSTOMIZE | | |
| | ALL | | |
| | • OPERATION | FORMAT | <ul style="list-style-type: none"> SYSTEM REC FORMAT BIT RATE (HD) AUDIO CH (HD) ASPECT RATIO (DV) COUNTRY |
| | | SPECIAL EFFECTS | <ul style="list-style-type: none"> CLIP CONT.REC INTERVAL REC INTERVAL TIME NUMBER OF FRAME NUMBER OF TIMES PRE-LIGHTING PICTURE CACHE CACHE REC TIME |
| | | ASSIGNABLE | <ul style="list-style-type: none"> ASSIGN SW <1> ASSIGN SW <2> ASSIGN SW <3> ASSIGN SW <4> |
| | | DISC | <ul style="list-style-type: none"> DELETE LAST CLIP DELETE ALL CLIPS QUICK FORMAT |
| | | CLIP TITLE | <ul style="list-style-type: none"> TITLE SELECT PREFIX CLEAR NUMERIC LOAD PREFIX DATA PREFIX NUMERIC |
| | | FILE NAMING | <ul style="list-style-type: none"> NAMING FORM AUTO NAMING |
| | | GAIN SW | <ul style="list-style-type: none"> GAIN LOW GAIN MID GAIN HIGH GAIN TURBO |
| | | EZ MODE/TLCS | <ul style="list-style-type: none"> TLCS MODE AGC LIMIT AGC CHANGE POINT AE LIMIT AE CHANGE POINT |
| | | OFFSET WHITE | <ul style="list-style-type: none"> OFFSET WHITE <A> WARM COOL <A> COLOR FINE <A> OFFSET WHITE WARM COOL COLOR FINE |
| | (Continued) | (Continued) | |

| Menu selection | 1st level | 2nd level | 3rd level |
|----------------|-------------|---------------|---|
| | | OUTPUT | COMPONENT OUT i.LINK MODE |
| | | VIDEO OUT | VIDEO OUT VFDISP VIDEO OUT MENU VIDEO OUT TC VIDEO OUT ZEBRA VIDEO OUT MARKER |
| | | VF SETTING | ZEBRA ZEBRA SELECT ZEBRA1 DET.LEVEL PEAKING VOL.LINK H DETAIL LEVEL V DETAIL LEVEL DETAIL FREQ VF ASPECT |
| | | MARKER | MARKER CENTER SAFETY ZONE SAFETY AREA ASPECT ASPECT SELECT |
| | | VF DISP 1 | DISP REC FORMAT DISP BIT RATE DISP SYSTEM DISP 16:9 DISP ZOOM DISP FOCUS DISP BATT REMAIN DISP REC/PLAY DISP TIME CODE |
| | | VF DISP 2 | DISP 5600K DISP FILTER DISP WHITE DISP GAIN DISP SHUTTER DISP AUDIO DISP DISC DISP IRIS DISP LOW LIGHT DISP INTERVAL |
| | | LCD | LCD COLOR LCD MARKER&ZEBRA |
| | | SHOT ID | ID-1 ID-2 ID-3 ID-4 |
| | | SHOT DISP | SHOT DATE DATE MODE SHOT TIME TIME MODE SHOT ID SEL |
| | | LENS FILE SEL | LENS FILE SELECT F.ID L.ID L.MF |
| | (Continued) | (Continued) | |

| Menu selection | 1st level | 2nd level | 3rd level |
|----------------|-------------|-------------|--|
| | | TIME/DATE | ADJUST HOUR MIN SEC YEAR MONTH DAY |
| | | UMID SET | COUNTRY CODE ORGANIZATION USER CODE TIME ZONE: 00 |
| | | RESET | ALL PRESET |
| | • PAINT | PAINT | A. IRIS DETAIL LEVEL MASTER BLACK GAMMA SELECT MASTER GAMMA BLACK GAMMA PRESET MTX SEL |
| | | SW STATUS | GAMMA MATRIX KNEE WHITE CLIP DETAIL |
| | | WHITE | COLOR TEMP <A> C TEMP BAL <A> R GAIN <A> B GAIN <A> D5600K<A> COLOR TEMP C TEMP BAL R GAIN B GAIN D5600K |
| | | KNEE | KNEE POINT KNEE SLOPE KNEE SAT LEVEL WHITE CLIP LEVEL |
| | | DETAIL | DETAIL LEVEL DTL H/V RATIO DETAIL FREQUENCY APERTURE LEVEL KNEE APT LEVEL SD DETAIL CROSS COLOR |
| | | SKIN DETAIL | SKIN DETAIL SKIN DETAIL LVL SKIN DETECT SKIN AREA IND. SKIN DTL SAT. SKIN DTL HUE SKIN DTL WIDTH |
| | | MATRIX 1 | MATRIX USER MATRIX USER MATRIX SAT USER MATRIX HUE PRESET MTX PRESET MTX SEL |
| | (Continued) | (Continued) | |

| Menu selection | 1st level | 2nd level | 3rd level |
|----------------|---------------|---------------|--|
| | | MATRIX 2 | <ul style="list-style-type: none"> — USER MATRIX R-G — USER MATRIX R-B — USER MATRIX G-R — USER MATRIX G-B — USER MATRIX B-R — USER MATRIX B-G |
| | | LOW KEY SAT | — L.KEY SAT LEVEL |
| | | SCENE FILE | <ul style="list-style-type: none"> — 1-5 — STANDARD — SCENE RECALL — SCENE STORE — F.ID |
| | • MAINTENANCE | AUDIO-1 | <ul style="list-style-type: none"> — AU REF LEVEL — AU AGC SPEC — AU LIMITER MODE — REAR MIC REF — FRONT MIC SELECT — AU CH12 AGC MODE — AU CH34 AGC MODE — AU SG (1KHz) |
| | | AUDIO-2 | <ul style="list-style-type: none"> — AU OUT LIMITER — HEADPHONE OUT — i.LINK AUDIO OUT — MIC CH1 LEVEL — MIC CH2 LEVEL — REAR1/WRR LEVEL — REAR2/WRR LEVEL |
| | | TIMECODE | <ul style="list-style-type: none"> — TC OUT — DF/NDF — UBIT |
| | | ESSENCE MARK | <ul style="list-style-type: none"> — SHOTMARK 1 — SHOTMARK 2 — INDEX PIC. POS — FIND MODE |
| | | WHITE SETTING | <ul style="list-style-type: none"> — COLOR TEMP <P> — C TEMP BAL <P> — WHITE SWITCH — ATW SPEED — SHOCKLESS WHITE — AWB FIXED AREA — WHT FILTER INH |
| | | CAM CONFIG | <ul style="list-style-type: none"> — COLOR BAR SEL — REC TALLY — SHT DISP MODE — IRIS OVER RIDE — LOW NOISE MODE — ANA V OUT SAVE |
| | | BATTERY 1 | <ul style="list-style-type: none"> — Info BEFORE END — Info END — Sony BEFORE END — Sony END — Other BEFORE END — Other END — DC IN BEFORE END — DC IN END — DETECTED BATTERY |
| | (Continued) | (Continued) | |

| Menu selection | 1st level | 2nd level | 3rd level |
|----------------|-------------|----------------|--|
| | | BATTERY 2 | TYPE DETECTION SEGMENT No.7 SEGMENT No.6 SEGMENT No.5 SEGMENT No.4 SEGMENT No.3 SEGMENT No.2 SEGMENT No.1 |
| | | GENLOCK | GL H PHASE H ADVANCE |
| | | LENS | ZOOM SELECT ZOOM SPEED AF DETECT AREA |
| | | SHUTTER SELECT | SHUTTER SELECT |
| | •FILE | USER FILE | USER FILE LOAD USER FILE SAVE F.ID USER PRESET CUSTOMIZE RESET |
| | | ALL FILE | ALL FILE LOAD ALL FILE SAVE F.ID ALL RESET |
| | | SCENE FILE | 1-5 STANDARD SCENE RECALL SCENE STORE F.ID |
| | | LENS FILE 1 | LENS FILE RECALL LENS FILE STORE F.ID SOURCE LENS NO OFFSET IRIS GAIN LENS AUTO RECALL <LENS INFORMATION> L.ID L.MF |
| | | LENS FILE 2 | LENS M VMOD LENS R FLARE LENS G FLARE LENS B FLARE LENS W-R OFST LENS W-B OFST |
| | | LENS FILE 3 | SHADING CH SEL LENS R H SAW LENS R H PARA LENS R V SAW LENS R V PARA |
| | | MEMORY STICK | MS FORMAT |
| | (Continued) | (Continued) | |

| Menu selection | 1st level | 2nd level | 3rd level | | | | | | | | |
|----------------|-------------|---------------|-----------------|-----------------|--------------|-----------------|------------------|----------------|----------------|-----------------|--------------|
| • DIAGNOSIS | HOURS METER | OPERATION | OPERATION (rst) | | | | | | | | |
| | | SPINDLE (rst) | LASER (rst) | | | | | | | | |
| | | LOADING (rst) | SEEK (rst) | | | | | | | | |
| | | DISC STATUS | USER ID | TITLE | | | | | | | |
| | | REMAIN | REWRITE | SALVAGE | FILE SYSTEM | | | | | | |
| | CLIP STATUS | CLIP NO. | NAME | TITLE | | | | | | | |
| | | RECORD DEVICE | SERIAL | DATE | | | | | | | |
| | | TIME | ROM VERSION | AT | PACKAGE | | | | | | |
| | • ADVANCED | LOW LIGHT | LOW LIGHT | LOW LIGHT LEVEL | BATTERY | | | | | | |
| | | | AUTO IRIS | IRIS OVER RIDE | IRIS SPEED | CLIP HIGH LIGHT | IRIS LEVEL | IRIS APL RATIO | | | |
| SW STATUS | | GAMMA | MATRIX | KNEE | WHITE CLIP | DETAIL | APERTURE | FLARE | | | |
| | | BLACK/FLARE | MASTER BLACK | R BLACK | B BLACK | MASTER FLARE | R FLARE | G FLARE | B FLARE | FLARE | |
| | | GAMMA | GAMMA | STEP GAMMA | MASTER GAMMA | R GAMMA | G GAMMA | B GAMMA | GAMMA SELECT | KNEE FIX (CINE) | |
| | | | DETAIL | DETAIL | CRISPENING | LEVEL DEPEND | DETAIL FREQUENCY | APERTURE | APERTURE LEVEL | KNEE APT LEVEL | DETAIL LIMIT |

(Continued)

| Menu selection | 1st level | 2nd level | 3rd level |
|----------------|-----------|---------------|--|
| | | SD DETAIL | <ul style="list-style-type: none"> SD DTL LEVEL-MID SD CRISPENING SD DTL LIMIT SD LEVEL DEPEND SD DTL FREQUENCY SD DTL H/V RATIO SD CROSS COLOR |
| | | WHITE SHADING | <ul style="list-style-type: none"> WHITE SHADING CH SEL VIDEO OUT SEL R WHT H SAW R WHT H PARA R WHT V SAW R WHT V PARA WHITE SAW/PARA |
| | | BLACK SHADING | <ul style="list-style-type: none"> BLACK SHADING CH SEL VIDEO OUT SEL R BLK H SAW R BLK H PARA R BLK V SAW R BLK V PARA BLACK SAW/PARA MASTER BLACK MASTER GAIN (TMP) |
| | | DCC | <ul style="list-style-type: none"> DCC D RANGE DCC POINT DCC GAIN DCC DELAY TIME |
| | | ND COMP | <ul style="list-style-type: none"> ND OFFSET ADJUST CLEAR ND OFFSET |

TOP Menu

The TOP menu consists of the following submenus.

| <TOP MENU> | |
|------------|---------------------|
| USER | USER MENU CUSTOMIZE |
| → USER | |
| ALL | OPERATION |
| · | PAINT |
| · | MAINTENANCE |
| · | FILE |
| · | DIAGNOSIS |
| · | ADVANCED |

When you select an item in the TOP menu, this displays the most recently shown page of the corresponding submenu. When the submenu is selected for the first time, the CONTENTS page appears.

USER menu

This menu allows you to add items from the OPERATION, PAINT, MAINTENANCE, FILE, DIAGNOSIS, and ADVANCED menus to suit your needs. By gathering frequently used items on the USER menu beforehand, you can call up them quickly whenever you need them.

Usually by flicking the MENU switch to ON, the USER menu is displayed.

USER MENU CUSTOMIZE menu

This menu allows you to add pages to or delete pages from the USER menu to suit your needs.

ALL menu

This menu contains all items of the OPERATION, PAINT, MAINTENANCE, FILE, DIAGNOSIS, and ADVANCED menus as they are in one menu.

OPERATION menu

This menu contains items for changing settings according to conditions related to the subject when the camcorder is being operated.

PAINT menu

This menu contains items for making detailed image adjustments while using a waveform monitor to monitor the waveforms output by the camera. Support of a video engineer is usually required to use this menu. Although you can also use an external remote control unit to set the items on this menu, this menu is effective when using the camcorder by itself outdoors.

MAINTENANCE menu

This menu includes contains items for making settings for audio, timecode, essence marks, and battery.

FILE menu

This menu is for saving the adjusted data in the camcorder memory or in a “Memory Stick”. The following files can be saved.

User file

In the user file, the setting items and setting data of the customized USER menu are saved. Once you save the user file in a “Memory Stick”, you can easily set the USER menu to your preference by loading the data from the “Memory Stick”.

For details on the user file, see “Saving and Loading User Files” on page 146.

ALL file

In the ALL file, the setting data of all of the menus are saved. Once a camcorder is set according to your preferences and you save its ALL file in a “Memory Stick”, you can easily set other camcorders to the settings of the camcorder that you already set by loading the data from the “Memory Stick”.

Items included in the ALL file are marked with an “A” in the “File” column on the menu list.

Scene file

In the scene file, the setting values of event items adjusted to shoot a particular scene are saved. You can save up to five scene files in the camcorder memory and up to 100 scene files in a “Memory Stick”. For example, first adjust the settings to shoot a particular scene at the rehearsal and then save them as a scene file. Then load this file before the actual shooting so that you can quickly recreate setup conditions that are the same as those in rehearsal.

Items included in the scene file are marked with an “Sc” in the “File” column on the menu list.

Lens file

In the lens file, the setting data used to compensate for the characteristics of lenses, such as flare, white shading, and auto iris gain, is saved. You can save up to 32 lens files in the camcorder memory and up to 100 lens files in a “Memory Stick”.

Items included in the lens file are marked with an “L” in the “File” column on the menu list.

DIAGNOSIS menu

This menu shows the digital hours meter, and disc and clip status information.

ADVANCED menu

This menu contains items for making advanced settings and adjustments, for example settings related to auto iris and gamma correction.

Menu List

For settings registered on a USER menu page at the factory, the “USER menu page” column in the following list indicates the number of that page.

The USER MENU CUSTOMIZE menu allows you to add and delete pages to and from the USER menu to suit your requirements.

Note

When the setting range in the “Settings” column is surrounded by parentheses (), the setup value is a relative value. The setting range shown on the menu screen may differ from what is shown in this manual.

“File” column

The letters in the “File” column stand for the following.

A: Items saved in the ALL file

Sc: Items saved in the scene file

L: Items saved in the lens file

St: Items whose setting is changed by the STANDARD operation

OPERATION menu

| OPERATION menu | | | | | | | |
|----------------|-----------------|-------------------|--|-----------|----------------|---|------|
| No. | Page | Item | Settings | Default | USER menu page | Description | File |
| 01 | FORMAT | SYSTEM | 60I / 30P / 23.9P (PAL: 50I / 25P) | 60I (50I) | 03 | See "Selecting the Recording Format" on page 53. | - |
| | | REC FORMAT | MPEG HD / DVCAM | MPEG HD | | | |
| | | BIT RATE (HD) | HQ / SP / LP | SP | | | |
| | | AUDIO CH (HD) | 2CH / 4CH | 4CH | | | |
| | | ASPECT RATIO (DV) | 16:9 / 4:3 | 16:9 | | | |
| | | COUNTRY | NTSC AREA / NTSC(J) AREA / PAL AREA | - | | | |
| 02 | SPECIAL EFFECTS | CLIP CONT.REC | ON / OFF | OFF | 04 | See "Recording with the Clip Continuous Rec Function" on page 73. See "Time-lapse Video Recording (Interval Rec Function)" on page 66. | A |
| | | INTERVAL REC | | | | | |
| | | INTERVAL TIME | 1SEC to 10SEC / 15SEC / 20SEC / 30SEC / 40SEC / 50SEC, 1MIN to 10MIN / 15MIN / 20MIN / 30MIN / 40MIN / 50MIN, 1H to 6H / 12H / 24H | 1SEC | | | |
| | | NUMBER OF FRAME | 1F / 3F / 6F | 1F | | | |
| | | NUMBER OF TIMES | CONT / 50 / 100 / 200 / 300 / 500 / 800 / 1000 | CONT | | | |
| | | PRE-LIGHTING | OFF / 2SEC / 5SEC / 10SEC | OFF | | | |
| | | PICTURE CACHE | ON / OFF | | | | |
| | | CACHE REC TIME | 0-2s / 2-4s / 4-6s / 6-8s / 8-10s / 10-12s | 0-2s | | | |
| 03 | ASSIGNABLE | ASSIGN SW <1> | OFF / | EZMOD | 05 | See "Assigning Functions to ASSIGN Switches" on page 143. | A |
| | | ASSIGN SW <2> | MARKER / | OFF | | | |
| | | ASSIGN SW <3> | ATW / LENS | | | | |
| | | ASSIGN SW <4> | RET / REC SWITCH / TURBO SWITCH, etc. | | | | |

| OPERATION menu | | | | | | | |
|----------------|---------------|------------------|--|---------|----------------|---|------|
| No. | Page | Item | Settings | Default | USER menu page | Description | File |
| 04 | DISC | DELETE LAST CLIP | EXEC | EXEC | 06 | Deletes a clip recorded on the disc. | - |
| | | DELETE ALL CLIPS | | | | Deletes all clips recorded on the disc. | |
| | | QUICK FORMAT | | | | Formats the disc. Any recorded content is lost. | |
| 05 | CLIP TITLE | TITLE | ENABL / DSABL | DSABL | - | See "Assigning User-Defined Clip Titles Automatically" on page 69. | A |
| | | SELECT PREFIX | EXEC | - | | | - |
| | | CLEAR NUMERIC | | | | | |
| | | LOAD PREFIX DATA | | | | | |
| | | PREFIX | | | | | A |
| | | NUMERIC | | | | | - |
| 06 | FILE NAMING | NAMING FORM | FREE / C**** | C**** | - | Specify the clip and clip list name format C****: Standard format FREE: Enable free format | A |
| | | AUTO NAMING | TITLE / C**** | | | Specify the format of the file names generated when clips are recorded C****: Standard format TITLE: Assign the same name as clip title | |
| 07 | GAIN SW | GAIN LOW | -3dB / 0dB / 3dB / 6dB / 9dB / 12dB / | 0dB | - | See "Setting Gain Values for the GAIN Switch Positions" on page 140. | A |
| | | GAIN MID | 18dB / 24dB / 30dB / 36dB / 42dB / 48dB | 9dB | | | |
| | | GAIN HIGH | | 18dB | | | |
| | | GAIN TURBO | | 42dB | | | |
| 08 | EZ MODE/ TLCS | TLCS MODE | AGC&AE / AGC / AE | AGC&AE | - | Selects the TLCS function in EZ mode. AGC&AE: automatic gain and shutter control AGC: automatic gain control only AE: automatic shutter control only | A |
| | | AGC-LIMIT | 0 / 3 / 6 / 9 / 12dB (normal setting value) | 12dB | | Sets the upper limit for AGC adjustment. This function operates only when using the EZ mode. | |
| | | AGC CHANGE POINT | OPEN / F2 / F2.8 / F4 / F5.6 | F2.8 | | Sets the f-stop for switching from automatic iris adjustment to AGC. This function operates only when using the EZ mode. | |
| | | AE-LIMIT | 1/100 to 1/250 | 1/250 | | Sets the upper limit for shutter adjustment. This function operates only when using the EZ mode. | |
| | | AE CHANGE POINT | F5.6 / F8 / F11 / F16 (normal setting value) | F16 | | Sets the f-stop for switching from automatic iris adjustment to AE. This function operates only when using the EZ mode. | |

| OPERATION menu | | | | | | | |
|----------------|--------------|-------------------|--|---------|----------------|---|------|
| No. | Page | Item | Settings | Default | USER menu page | Description | File |
| 09 | OFFSET WHITE | OFFSET WHITE <A> | ON / OFF | OFF | - | See "Specifying an Offset for the Auto White Balance Setting" on page 141. | A |
| | | WARM-COOL <A> | Display color temperature (converted from R/B Gain). | 3200 | | | |
| | | COLOR FINE <A> | (-99 to +99) | 0 | | | |
| | | OFFSET WHITE | ON / OFF | OFF | | | |
| | | WARM-COOL | Display color temperature (converted from R/B Gain). | 3200 | | | |
| | | COLOR FINE | (-99 to +99) | 0 | | | |
| 10 | OUTPUT | COMPONENT OUT | AUTO / HD YPbPr / SD YPbPr | AUTO | 07 | Selects the output from the BNC connector on the side panel of this unit. AUTO: Switch between HD YPbPr and SD YPbPr, according to the recording format. (For both recording and playback) HD YPbPr: Regardless of the recording format, output HD YPbPr when recording. Output SD YPbPr only when playing back DVCAM format. SD YPbPr: Regardless of the recording format, output SD YPbPr. (For both recording and playback) | A |
| | | HD→SD (PLAYBACK) | 16:9 / 4:3 | 16:9 | | Selects the aspect ratio for output to an SD monitor after downconvert during playback of material recorded in HD. You can select 16:9 (squeeze) or 4:3 (crop). | |
| | | i.LINK MODE | AV/C /FAM | AV/C | | - | |
| 11 | VIDEO OUT | VIDEO OUT VF DISP | ON / OFF | ON | - | Selects whether or not the VF DISP display signal is mixed to the output signal from the VIDEO OUT connector. | A |
| | | VIDEO OUT MENU | | | | Selects whether or not the menu display signal is mixed to the output signal from the VIDEO OUT connector. | |
| | | VIDEO OUT TC | | | | Selects whether or not the timecode is mixed to the output signal from the VIDEO OUT connector. | |
| | | VIDEO OUT ZEBRA | | OFF | | Selects whether or not the zebra mark display signal is mixed to the output signal from the VIDEO OUT connector. | |
| | | VIDEO OUT MARKER | | | | Selects whether or not the marker signal is mixed to the output signal from the VIDEO OUT connector. | |

| OPERATION menu | | | | | | | |
|----------------|------------|--------------------|------------------------------|---------|----------------|---|------|
| No. | Page | Item | Settings | Default | USER menu page | Description | File |
| 12 | VF SETTING | ZEBRA | ON / OFF | ON | 08 | See "Setting the Viewfinder Screen Display" on page 137. | – |
| | | ZEBRA SELECT | 1 / 2 / BOTH | 1 | | | A |
| | | ZEBRA1 DET.LEVEL | 30% to 107% (in 1% steps) | 70% | | | |
| | | PEAKING VOL.LINK | ON / OFF | ON | | | |
| | | H DETAIL LEVEL | (-99 to +99) | 0 | | | |
| | | V DETAIL LEVEL | | | | | |
| | | DETAIL FREQ | NORM / HIGH | HIGH | | | |
| | | VF ASPECT | AUTO / 4:3 | AUTO | | | |
| 13 | MARKER | MARKER | ON / OFF | OFF | 09 | See "Setting the Marker Display" on page 136. | A |
| | | CENTER | | ON | | | |
| | | SAFETY ZONE | | | | | |
| | | SAFETY AREA | 80% / 90% / 92% / 95% | 90% | | | |
| | | ASPECT | ON / OFF | OFF | | | |
| | | ASPECT SELECT | 14:9 / 13:9 / 4:3 | 4:3 | | | |
| 14 | VF DISP 1 | DISP REC FORMAT | ON / OFF | ON | – | See "Selecting the Display Items" on page 135. | A |
| | | DISP BIT RATE | | | | | |
| | | DISP SYSTEM | | | | | |
| | | DISP 16:9 | | | | | |
| | | DISP ZOOM | | | | | |
| | | DISP FOCUS | | | | | |
| | | DISP BATT REMAIN | INT / VOLT / AUTO | AUTO | | | |
| | | DISP REC / PLAY | ON / OFF | ON | | | |
| | | DISP TIME CODE | | OFF | | | |
| 15 | VF DISP 2 | DISP 5600K | ON / OFF | ON | – | See "Selecting the Display Items" on page 135. | A |
| | | DISP FILTER | | | | | |
| | | DISP WHITE | | | | | |
| | | DISP GAIN | | | | | |
| | | DISP SHUTTER | | | | | |
| | | DISP AUDIO | | | | | |
| | | DISP DISC | TIME / CLIP / OFF | TIME | | | |
| | | DISP IRIS | ON / OFF | ON | | | |
| | | DISP LOW LIGHT | | | | | |
| | | DISP INTERVAL | | | | | |
| 16 | LCD | LCD COLOR | -137 to +62 | 0 | – | Adjusts the LCD color. | A |
| | | LCD MARKER & ZEBRA | ON / OFF | ON | | Selects whether to add the marker and zebra to the LCD display, in the same way as in the viewfinder. | |

| OPERATION menu | | | | | | | |
|----------------|---------------|------------------|--|---|----------------|---|------|
| No. | Page | Item | Settings | Default | USER menu page | Description | File |
| 17 | SHOT ID | ID-1 | Displays character input mode (up to 12 characters). | Blank | – | See “Setting the Shot ID” on page 138. | A |
| | | ID-2 | | | | | |
| | | ID-3 | | | | | |
| | | ID-4 | | | | | |
| 18 | SHOT DISP | SHOT DATE | ON / OFF | OFF | – | See “Recording Shot Data Superimposed on the Color Bars” on page 137. | A |
| | | DATE MODE | Y/M/D / M/D/Y / D/M/Y | Y/M/D | | | |
| | | SHOT TIME | ON / OFF | OFF | | | |
| | | TIME MODE | 12H / 24H | 24H | | | |
| | | SHOT ID SEL | OFF / ID-1 / ID-2 / ID-3 / ID-4 | OFF | | | |
| 19 | LENS FILE SEL | LENS FILE SELECT | 1 to 32 | 1 | – | Selects a lens file. Up to 32 files can be registered. | L |
| | | F.ID | – | Indicates the name of the selected lens file. | | | |
| | | L.ID | | Indicates the name of the lens file corresponding to the connected serial lens. | | | |
| | | L.MF | | Indicates the fabricator of the connected serial lens. | | | |
| 20 | TIME / DATE | ADJUST | Displays the TIME ADJUST selection screen. | EXEC | – | See “Setting the Date and Time of the Internal Clock” on page 34. | – |
| | | HOUR | 00 to 23 | Internal clock | | | |
| | | MIN | 00 to 59 | | | | |
| | | SEC | | | | | |
| | | YEAR | 00 to 99 | | | | |
| | | MONTH | 01 to 12 | | | | |
| | | DAY | 01 to 31 | | | | |
| 21 | UMID SET | COUNTRY CODE | 4-byte alphanumeric strings | – | – | See “Using UMID Data” on page 174. | A |
| | | ORGANIZATION | | | | | |
| | | USER CODE | | | | | |
| | | TIME ZONE | | | | | |
| 22 | RESET | ALL PRESET | EXEC | EXEC | 11 | Resets all settings at the USER level. | – |

PAINT menu

| PAINT menu | | | | | | | |
|------------|-----------|----------------|---|---------|----------------|--|-----------|
| No. | Page | Item | Settings | Default | USER menu page | Description | File |
| 01 | PAINT | A.IRIS | -1.0 / -0.5 / ±0 / +0.5 / +1.0 | ±0 | 01 | – | – |
| | | DETAIL LEVEL | – | 0 | | Detail level adjustment | A, Sc, St |
| | | MASTER BLACK | | | | Master black level adjustment | |
| | | GAMMA SELECT | STD / CINE1 / CINE2 / CINE3 / CINE4 | STD | | See “ <i>Selecting Gamma Tables</i> ” on page 142. | |
| | | MASTER GAMMA | (0 to 199) | 0 | | Sets master gamma correction curve. | |
| | | BLACK GAMMA | | | | Black gamma correction | |
| | | PRESET MTX SEL | STD / HISAT / FL / CINE | STD | | Matrix selection | |
| 02 | SW STATUS | GAMMA | ON / OFF | ON | – | Turns the gamma correction on or off. | |
| | | MATRIX | | | | Turns the linear matrix correction on or off. | |
| | | KNEE | | | | Turns the knee correction on or off. | |
| | | WHITE CLIP | | | | Turns the white clipping correction on or off. | |
| | | DETAIL | | | | Turns the detail signal on or off. | |

| PAINT menu | | | | | | | | |
|------------|--------|------------------|--|---------|----------------|--|-----------|--|
| No. | Page | Item | Settings | Default | USER menu page | Description | File | |
| 03 | WHITE | COLOR TEMP <A> | Display color temperature (converted from R/B Gain). | 3200 | - | Sets the color temperature of WHITE A. | A | |
| | | C TEMP BAL <A> | (-99 to +99) | 0 | | Adjusts the value more precisely when the color temperature adjustment through COLOR TEMP is not satisfactory. | | |
| | | R GAIN <A> | | | | Only the value of R GAIN is changed. | | |
| | | B GAIN <A> | | | | Only the value of B GAIN is changed. | | |
| | | D5600K<A> | ON / OFF | OFF | | Turns the WHITE A electronic 5600K filter on or off. | | |
| | | COLOR TEMP | Display color temperature (converted from R/B Gain). | 3200 | | Sets the color temperature of WHITE B. | | |
| | | C TEMP BAL | (-99 to +99) | 0 | | Adjusts the value more precisely when the color temperature adjustment through COLOR TEMP is not satisfactory. | | |
| | | R GAIN | | | | Only the value of R GAIN is changed. | | |
| | | B GAIN | | | | Only the value of B GAIN is changed. | | |
| | | D5600K | ON / OFF | OFF | | Turns the WHITE B electronic 5600K filter on or off. | | |
| 04 | KNEE | KNEE POINT | 50.0 to 109 .0 (in 0.1 steps) | 100.0 | - | Sets the knee point level. | A, Sc, St | |
| | | KNEE SLOPE | - | 0 | | Sets the knee slope level. | | |
| | | KNEE SAT LEVEL | (0 to 199) | | | Sets the knee saturation level. | | |
| | | WHITE CLIP LEVEL | 100.0 to 109.5 (in 0.1 steps) | 108.0 | | Adjusts the white clipping level. | | |
| 05 | DETAIL | DETAIL LEVEL | - | 0 | - | Sets the general level of the detail signal. | A, Sc, St | |
| | | DTL H/V RATIO | | | | Sets the level of the V detail signal. | | |
| | | DETAIL FREQUENCY | | | | Sets the frequency of the H detail signal. | | |
| | | APERTURE LEVEL | | | | Sets the aperture level. | | |
| | | KNEE APT LEVEL | | | | Sets the knee aperture level. | | |
| | | SD DETAIL | LOW / MID / HIGH | | | MID | | Detail setting for down-converted SD |
| | | CROSS COLOR | ON / OFF | | | ON | | Turns the cross color component on or off. |

| PAINT menu | | | | | | | |
|------------|-------------|-----------------|--------------------------------|---------|----------------|---|-----------|
| No. | Page | Item | Settings | Default | USER menu page | Description | File |
| 06 | SKIN DETAIL | SKIN DETAIL | ON / OFF | OFF | 10 | Sets the skin detail on or off. | A, Sc, St |
| | | SKIN DETAIL LVL | – | 0 | | Sets the detail level of detected color. | |
| | | SKIN DETECT | Moves to color detection page. | EXEC | | – | |
| | | SKIN AREA IND. | ON / OFF | OFF | | Turns the indicator of detected color on or off. | St |
| | | SKIN DTL SAT. | (–99 to +99) | 0 | | Adjusts the saturation level for skin detail. | A, Sc, St |
| | | SKIN DTL HUE | 0 to 359 | | | Adjusts the center phase for skin detail. | |
| | | SKIN DTL WIDTH | 0 to 90 | 40 | | Adjusts the width for skin detail. | |
| 07 | MATRIX 1 | MATRIX | ON / OFF | ON | – | Turns the linear matrix correction and user matrix correction functions on or off. | A, Sc, St |
| | | USER MATRIX | | OFF | | Turns the user matrix correction function on or off. | |
| | | USER MATRIX SAT | (–99 to +99) | 0 | | Adjusts the saturation level affected by the user matrix correction function. | |
| | | USER MATRIX HUE | | | | Adjusts the color phase affected by the user matrix correction function. | |
| | | PRESET MTX | ON / OFF | ON | | Turns the preset matrix correction function on and off. | |
| | | PRESET MTX SEL | STD / HISAT / FL / CINE | STD | | When PRESET MTX is set to ON, selects the matrix adjustment value. STD: settings for standard shooting conditions HISAT: settings for high saturation shooting FL: settings for fluorescent illumination CINE: settings to evoke the impression of film camera shooting | |
| 08 | MATRIX 2 | USER MATRIX R-G | (–99 to +99) | 0 | – | Sets the arbitrary R-G user-set matrix coefficients. | A, Sc, St |
| | | USER MATRIX R-B | | | | Sets the arbitrary R-B user-set matrix coefficients. | |
| | | USER MATRIX G-R | | | | Sets the arbitrary G-R user-set matrix coefficients. | |
| | | USER MATRIX G-B | | | | Sets the arbitrary G-B user-set matrix coefficients. | |
| | | USER MATRIX B-R | | | | Sets the arbitrary B-R user-set matrix coefficients. | |
| | | USER MATRIX B-G | | | | Sets the arbitrary B-G user-set matrix coefficients. | |
| 09 | LOW KEY SAT | L.KEY SAT LEVEL | (–99 to +99) | 0 | – | Sets the saturation level of the low luminance part. | A, Sc, St |

| PAINT menu | | | | | | | |
|------------|--|-----------------------------------|---|--|----------------|---|------|
| No. | Page | Item | Settings | Default | USER menu page | Description | File |
| 10 | SCENE FILE | <input type="checkbox"/> 1 | - | STANDARD | 02 | Recalls a scene file saved in the camcorder memory. | - |
| | | <input type="checkbox"/> 2 | | | | | |
| | | <input type="checkbox"/> 3 | | | | | |
| | | <input type="checkbox"/> 4 | | | | | |
| | | <input type="checkbox"/> 5 | | | | | |
| | | <input type="checkbox"/> STANDARD | - | Clears all current detail-adjusted settings and switch settings and returns the settings to the standard settings saved in the reference file. | | | |
| | | SCENE RECALL | Displays the SCENE FILE selection screen. | EXEC | | Recalls a scene file from the camcorder memory or the "Memory Stick". | |
| | | SCENE STORE | | | | Stores a scene file in the camcorder memory or the "Memory Stick". | |
| F. ID | Displays character input mode (up to 16 characters). | Blank | Sets the File ID. | Sc | | | |

MAINTENANCE menu

| MAINTENANCE menu | | | | | | | |
|------------------|---------|------------------|------------------------------------|---------|----------------|---|------|
| No. | Page | Item | Settings | Default | USER menu page | Description | File |
| 01 | AUDIO-1 | AU REF LEVEL | -20 / -18 / -16 / -12 dB | -20 dB | - | Sets the output level of the 1 kHz test signal. | A |
| | | AU AGC SPEC | -6 / -9 / -12 / -15 / -17 dB | -6 dB | | AGC characteristic (saturation level) setting | |
| | | AU LIMITER MODE | OFF / -6 / -9 / -12 / -15 / -17 dB | OFF | | During manual adjustment of audio input levels, selects the limiter characteristics (saturation level) for large input signals. | |
| | | REAR MIC REF | -60 / -50 / -40 dB | -60 dB | | Selects the reference input level when the AUDIO IN CH1 switch or AUDIO IN CH2 switch is set to MIC. | |
| | | FRONT MIC SELECT | MONO / STEREO | STEREO | | Input mode selection for front microphone | |
| | | AU CH12 AGC MODE | | MONO | | Selects whether to carry out automatic adjustment of the input levels of analog audio signals recorded on channels 1 and 2 independently for the two channels or to carry it out in stereo mode. | |
| | | AU CH34 AGC MODE | OFF / MONO / STEREO | | | Selects whether to carry out automatic adjustment of the input levels of analog audio signals recorded on channels 3 and 4 independently for the two channels, to carry it out in stereo mode, or not at all. | |
| | | AU SG (1KHz) | ON / OFF / AUTO | OFF | | In the color bar mode, selects whether to output a 1 kHz test signal. ON: Output. OFF: Do not output. AUTO: Output the test signal only when the AUDIO SELECT (CH-1) switch is set to AUTO. | |

| MAINTENANCE menu | | | | | | | |
|------------------|---------|------------------|------------------------|---------|----------------|--|------|
| No. | Page | Item | Settings | Default | USER menu page | Description | File |
| 02 | AUDIO-2 | AU OUT LIMITER | ON / OFF | ON | - | Turns the audio output limiter on or off | A |
| | | HEADPHONE OUT | STEREO / MONO | MONO | | Selects whether the earphones are monaural or stereo. | |
| | | i.LINK AUDIO OUT | 2CH / 4CH | 2CH | | 2CH: Output channels 1 and 2 (16 bits, 48 ksp/s) 4CH: Output channels 1 to 4 (12 bits, 32 ksp/s) | |
| | | MIC CH1 LEVEL | SIDE1 / FRONT / F + S1 | FRONT | | Selects the knob to use in adjustments when recording the front microphone to channel 1. SIDE1: Adjust with the left-hand AUDIO LEVEL knob on the side control panel. FRONT: Adjust with the AUDIO LEVEL knob on the front. F + S1: Allow adjustment with either of the left-hand AUDIO LEVEL knob on the side control panel or the AUDIO LEVEL knob on the front. (The two knobs function in linkage.) | |
| | | MIC CH2 LEVEL | SIDE2 / FRONT / F + S2 | | | Selects the knob to use in adjustments when recording the front microphone to channel 2. SIDE2: Adjust with the right-hand AUDIO LEVEL knob on the side control panel. FRONT: Adjust with the AUDIO LEVEL knob on the front. F + S2: Allow adjustment with either of the right-hand AUDIO LEVEL knob on the side control panel or the AUDIO LEVEL knob on the front. (The two knobs function in linkage.) | |
| | | REAR1/WRR LEVEL | SIDE1 / FRONT / F + S1 | SIDE1 | | Selects the knob to use in adjustments when recording the AUDIO IN CH1 or WIRELESS to channel 1. SIDE1: Adjust with the left-hand AUDIO LEVEL knob on the side control panel. FRONT: Adjust with the AUDIO LEVEL knob on the front. F + S1: Allow adjustment with either of the left-hand AUDIO LEVEL knob on the side control panel or the AUDIO LEVEL knob on the front. (The two knobs function in linkage.) | |

| MAINTENANCE menu | | | | | | | |
|------------------|--------------|-----------------|---|---------|----------------|--|------|
| No. | Page | Item | Settings | Default | USER menu page | Description | File |
| 02 | AUDIO-2 | REAR2/WRR LEVEL | SIDE2 / FRONT / F + S2 | SIDE2 | – | Selects the knob to use in adjustments when recording the AUDIO IN CH2 or WIRELESS to channel 2. SIDE2: Adjust with the right-hand AUDIO LEVEL knob on the side control panel. FRONT: Adjust with the AUDIO LEVEL knob on the front. F + S2: Allow adjustment with either of the right-hand AUDIO LEVEL knob on the side control panel or the AUDIO LEVEL knob on the front. (The two knobs function in linkage.) | A |
| 03 | TIMECODE | TC OUT | AUTO / GENE | AUTO | – | Timecode output setting AUTO: For recording, the timecode generator value is output, and for playback, the value from timecode reader is output. GENE: The timecode generator value is output for both recording and playback. | A |
| | | DF / NDF | DF / NDF | DF | | DF / NDF setting DF: drop-frame mode NDF: non-drop-frame mode | |
| | | UBIT | FIX / TIME | FIX | | Selects the user bit contents. | |
| 04 | ESSENCE MARK | SHOTMARK 1 | ON / OFF | ON | – | See “Recording Shot Marks” on page 65. | A |
| | | SHOTMARK 2 | | | | | |
| | | INDEX PIC. POS | 0 / 1 / 2 / 3 / 4 / 5 / 6 / 7 / 8 / 9 / 10SEC | 0SEC | | Sets the position of the index frame of a clip, in seconds from the start of recording. | |
| | | FIND MODE | R.ST / CLIP | R.ST | | Specifies what to find when the NEXT or PREV button is pressed. R.ST: Jump to the next or previous REC START essence mark. CLIP: Jump to the first frame of the next or current clip. (But jump to the first frame of the previous clip when the PREV button is pressed at the first frame of the current clip.) | |

| MAINTENANCE menu | | | | | | | |
|------------------|---------------|------------------|---|---------|----------------|---|------|
| No. | Page | Item | Settings | Default | USER menu page | Description | File |
| 05 | WHITE SETTING | COLOR TEMP <P> | Displays color temperature (converted from R/B Gain). | 3200 | - | Preset white balance color temperature setting. | A |
| | | C TEMP BAL <P> | (-99 to +99) | 0 | | Finer setting when the desired color could not be obtained with the COLOR TEMP <P> color temperature setting | |
| | | WHITE SWITCH | ATW / MEM | MEM | | Selects mode when the WHITE BAL switch is in the B position. ATW: auto tracking white balance MEM: auto white balance | |
| | | ATW SPEED | 1 / 2 / 3 / 4 / 5 | 4 | | Switches the ATW transition speed. | |
| | | SHOCKLESS WHITE | OFF / 1 / 2 / 3 | 1 | | Selects whether to enable the function that smooths out the white gain variation as the WHITE BAL switch is switched, and sets the transition rate. (1 represents the fastest.) | |
| | | AWB FIXED AREA | ON / OFF | OFF | | Increases the AWB speed. | |
| | | WHT FILTER INH | | ON | | Turns on and off the function which inhibits independent white balance memory for each filter position. | |
| 06 | CAM CONFIG | COLOR BAR SEL | MULTI / 75% / 100% | MULTI | - | Selects color bar type. | A |
| | | REC TALLY | UPPER / BOTH | UPPER | | Selects whether to light the upper REC/TALLY indicator only, or both upper and lower indicators. | |
| | | SHT DISP MODE | SEC / DEG | SEC | | Selects whether the SHUTTER indication is shown as a time indication or as an angle indication. | |
| | | IRIS OVER RIDE | ON / OFF | ON | | Turns on and off the function which changes the reference value for automatic iris adjustment. | |
| | | LOW NOISE MODE | OFF / 1 / 2 | OFF | | Turns on and off the function which enables clear, low-noise video under low light conditions. | |
| | | ANA V OUT SAVE | ON / OFF | ON | | ON | |

| MAINTENANCE menu | | | | | | | |
|------------------|-----------|------------------|--|---------|----------------|---|------|
| No. | Page | Item | Settings | Default | USER menu page | Description | File |
| 07 | BATTERY 1 | Info BEFORE END | 5 / 10 / 15 ...95 / 100% | 5% | - | Used when a BP-GL95/GL65 Battery Pack is used. Sets the remaining power (% value) of the battery at which the BEFORE END warning should be issued. ¹⁾ | A |
| | | Info END | 0 / 1 / 2 / 3 / 4 / 5% | 0% | | Used when a BP-GL95/GL65 Battery Pack is used. Sets the remaining power (% value) of the battery at which the END warning should be issued. ²⁾ | |
| | | Sony BEFORE END | 11.5 to 17.0V (in 0.1 V steps) | 11.5V | | Used when a BP-L60S/L80S Battery Pack is used. Sets the voltage level of the battery at which the BEFORE END warning should be issued. ¹⁾ | |
| | | Sony END | 11.0 to 11.5V (in 0.1 V steps) | 11.0V | | Used when a BP-L60S/L80S Battery Pack is used. Sets the voltage level of the battery at which the END warning should be issued. ²⁾ | |
| | | Other BEFORE END | 11.5 to 17.0V (in 0.1 V steps) | 11.8V | | Used when a battery pack other than a BP-GL95/GL65/L60S/L80S is used. Sets the voltage level of the battery at which the BEFORE END warning should be issued. | |
| | | Other END | 11.0 to 14.0V (in 0.1 V steps) | 11.0V | | Used when a battery pack other than a BP-GL95/GL65/L60S/L80S is used. Sets the voltage level of the battery at which the END warning should be issued. | |
| | | DC IN BEFORE END | 11.5 to 17.0V (in 0.1 V steps) | 11.8V | | Used when an external power source is connected to the DC IN connector. Sets the voltage level of the connected external power source at which the BEFORE END warning should be issued. | |
| | | DC IN END | 11.0 to 14.0V (in 0.1 V steps) | 11.0V | | Used when an external power source is connected to the DC IN connector. Sets the voltage level of the connected external power source at which the END warning should be issued. | |
| | | DETECTED BATTERY | Info / Sony / Other / DC IN (display only) | - | | Displays the type of automatically detected battery. | - |

| MAINTENANCE menu | | | | | | | |
|------------------|-----------|----------------|--------------------------------|---------|----------------|---|------|
| No. | Page | Item | Settings | Default | USER menu page | Description | File |
| 08 | BATTERY 2 | TYPE DETECTION | AUTO / OTHER | AUTO | - | AUTO: Automatically detects battery type. OTHER: Determines battery type as always "Others". | A |
| | | SEGMENT NO.7 | 11.0 to 17.0V (in 0.1 V steps) | 17.0V | | When "Others" is determined, remaining battery capacity indicator segment 7 lights when below the set voltage. [Battery capacity indicator segment] E ■■■■■■ F 1 2 3 4 5 6 7 | |
| | | SEGMENT NO.6 | | 16.0V | | When "Others" is determined, remaining battery capacity indicator segment 6 lights when below the set voltage. | |
| | | SEGMENT NO.5 | | 15.0V | | When "Others" is determined, remaining battery capacity indicator segment 5 lights when below the set voltage. | |
| | | SEGMENT NO.4 | | 14.0V | | When "Others" is determined, remaining battery capacity indicator segment 4 lights when below the set voltage. | |
| | | SEGMENT NO.3 | | 13.0V | | When "Others" is determined, remaining battery capacity indicator segment 3 lights when below the set voltage. | |
| | | SEGMENT NO.2 | | 12.0V | | When "Others" is determined, remaining battery capacity indicator segment 2 lights when below the set voltage. | |
| | | SEGMENT NO.1 | | 11.0V | | When "Others" is determined, remaining battery capacity indicator segment 1 lights when below the set voltage. | |
| 09 | GENLOCK | GL H PHASE | (-99 to +99) | 0 | - | Sets horizontal phase for genlock. | A |
| | | H ADVANCE | 0H / 90H | 0H | | Selects the output phase when an SD reference signal is input. 0H: Make SD REF and HD OUT in phase. 90H: Make the HD OUT phase 90H with offset respect to the SD reference signal (When an HD reference signal is input, HD REF and HD OUT are in phase.) | |

| MAINTENANCE menu | | | | | | | |
|------------------|----------------|----------------|-----------------|---------|----------------|--|------|
| No. | Page | Item | Settings | Default | USER menu page | Description | File |
| 10 | LENS | ZOOM SELECT | 1 / 2 | 1 | - | When a 1/2-inch lens is mounted, set this item according to the manufacturer of the lens (some lenses do not require a setting). 1: Select when you are using a Canon lens 2: Select when you are using a Fujinon lens | A |
| | | ZOOM SPEED | 0 to 99 | 20 | | Switches the zoom speed. | |
| | | AF DETECT AREA | FULL / CENTER | CENTER | | Selects the auto focus detection area. | |
| 11 | SHUTTER SELECT | SHUTTER SELECT | SECOND / DEGREE | SECOND | - | When DEGREE is selected, this item allows you to set the shutter speed to one of six settings. SECOND: Sets the shutter speed in units of seconds. DEGREE: Sets the shutter speed in units of degrees. | A |

1) When TYPE DETECTION on the BATTERY 2 page is set to OTHER, this follows the setting of BEFORE END.

2) When TYPE DETECTION on the BATTERY 2 page is set to OTHER, this follows the setting of END.

FILE menu

| FILE menu | | | | | | | | |
|-----------|-----------|-----------------|---|---------|----------------|--|------|---|
| No. | Page | Item | Settings | Default | USER menu page | Description | File | |
| 01 | USER FILE | USER FILE LOAD | Displays the USER FILE selection screen. | EXEC | - | See "Saving and Loading User Files" on page 146. | - | |
| | | USER FILE SAVE | | | | | | |
| | | F. ID | Displays character input mode (up to 16 character). | Blank | | | | |
| | | USER PRESET | After asking YES / NO, executes the function. | EXEC | | | | See "Resetting USER Menu Settings to the Factory Default Settings" on page 135. |
| | | CUSTOMIZE RESET | | | | | | Returns the pages registered in the USER menu to the factory default state. |

| FILE menu | | | | | | | |
|-----------|--|-----------------------------------|--|----------|----------------|--|------|
| No. | Page | Item | Settings | Default | USER menu page | Description | File |
| 02 | ALL FILE | ALL FILE LOAD | Displays the FILE selection screen. | EXEC | - | Loads ALL file. | - |
| | | ALL FILE SAVE | | | | Saves ALL file. | |
| | | F. ID | Displays character input mode (up to 16 character). | Blank | | Names ALL file. | A |
| | | ALL PRESET | After asking YES / NO, executes the function. | EXEC | | Returns items in ALL file to preset values. | - |
| 03 | SCENE FILE | <input type="checkbox"/> 1 | - | STANDARD | - | See "Saving and Loading User Files" on page 146. | - |
| | | <input type="checkbox"/> 2 | | | | | |
| | | <input type="checkbox"/> 3 | | | | | |
| | | <input type="checkbox"/> 4 | | | | | |
| | | <input type="checkbox"/> 5 | | | | | |
| | | <input type="checkbox"/> STANDARD | | | | | |
| | | SCENE RECALL | Displays the SCENE FILE selection screen. | EXEC | | | Sc |
| | | SCENE STORE | | | | | |
| F. ID | Displays character input mode (up to 16 characters). | Blank | | | | | |
| 04 | LENS FILE 1 | LENS FILE RECALL | Displays the FILE selection screen. | EXEC | - | Loads lens file. | - |
| | | LENS FILE STORE | | | | Saves lens file. | |
| | | F. ID | Displays character input mode (up to 16 characters). | Blank | | Names lens file. | L |
| | | SOURCE | - | - | | Displays number of selected lens file. | - |
| | | LENS NO OFFSET | After asking YES / NO, executes the function. | EXEC | | Resets the lens file to standard. | |
| | | IRIS GAIN | (-99 to +99) | - | | Adjusts the response speed of the auto iris according to the lens. | L |
| | | LENS AUTO RECALL | ON / OFF | | | Selects whether to automatically read in a lens file. | A |
| | | <LENS INFORMATION> | - | | | - | - |
| | | L.ID | | | | Lens file name for connected serial lens | |
| | | L.MF | | | | Lens manufacturer for connected serial lens | |

| FILE menu | | | | | | | | |
|-----------|--------------|----------------|---|---------|----------------|--|--------------------------|---|
| No. | Page | Item | Settings | Default | USER menu page | Description | File | |
| 05 | LENS FILE 2 | LENS M VMOD | (-99 to +99) | 0 | - | Sets lens file V SAW shading. | L | |
| | | LENS R FLARE | | | | Adjusts lens file flare (R). | | |
| | | LENS G FLARE | | | | Adjusts lens file flare (G). | | |
| | | LENS B FLARE | | | | Adjusts lens file flare (B). | | |
| | | LENS W-R OFST | | | | Compensates R value when extender and shrinker used. | | |
| | | LENS W-B OFST | | | | Compensates B value when extender and shrinker used. | | |
| 06 | LENS FILE 3 | SHADING CH SEL | R / G / B | R | - | Selects the channel adjusted by this menu. | - | |
| | | LENS R H SAW | (-99 to +99) | 0 | | - | White shading correction | L |
| | | LENS R H PARA | | | | | | |
| | | LENS R V SAW | | | | | | |
| | | LENS R V PARA | | | | | | |
| 07 | MEMORY STICK | MS FORMAT | After asking YES / NO, executes the function. | EXEC | - | | | |

DIAGNOSIS menu

| DIAGNOSIS menu | | | | | | | |
|----------------|-------------|-----------------|--------------|---------|----------------|--|------|
| No. | Page | Item | Settings | Default | USER menu page | Description | File |
| 01 | HOURS METER | OPERATION | Display only | - | - | Shows cumulative time that this unit has been powered on, in units of 1 hour. | - |
| | | OPERATION (rst) | | | | Shows cumulative time that this unit has been powered on, in units of 1 hour (resettable). | |
| | | SPINDLE (rst) | | | | Shows cumulative total time of spindle rotation, in units of 1 hour (resettable). | |
| | | LASER | | | | Shows cumulative light output parameters of optical head. | |
| | | LOADING (rst) | | | | Shows cumulative count of disc insertions (resettable). | |
| | | SEEK (rst) | | | | Shows cumulative total of optical head seek operation time, in units of 1 hour (resettable). | |

| DIAGNOSIS menu | | | | | | | |
|----------------|-------------|---------------|--------------|---------|----------------|---|------|
| No. | Page | Item | Settings | Default | USER menu page | Description | File |
| 02 | DISC STATUS | USER ID | Display only | - | - | Shows the user ID on the disc itself. | - |
| | | TITLE | | | | Shows the title on the disc itself. | |
| | | REMAIN | | | | Shows the remaining disc capacity. | |
| | | REWRITE | | | | Shows number of rewrites. | |
| | | SALVAGE | | | | When salvage is required, shows "required". | |
| | | FILE SYSTEM | | | | When the file system cannot be recognized or there is a fault, shows "unknown". | |
| 03 | CLIP STATUS | CLIP NO. | Display only | - | - | In NORMAL MODE: current clip number/total clip count In CLIP LIST MODE: clip list number | - |
| | | NAME | | | | In NORMAL MODE: current clip name In CLIP LIST MODE: clip list name | |
| | | TITLE | | | | In NORMAL MODE: current clip title In CLIP LIST MODE: clip list title | |
| | | RECORD DEVICE | | | | In NORMAL MODE: name of device on which current clip was recorded In CLIP LIST MODE: shows "----". | |
| | | SERIAL | | | | In NORMAL MODE: serial number of device on which current clip was recorded In CLIP LIST MODE: shows "-----". | |
| | | DATE | | | | In NORMAL MODE: date current clip was recorded In CLIP LIST MODE: date clip list was created | |
| | | TIME | | | | In NORMAL MODE: time current clip was recorded In CLIP LIST MODE: time clip list was created | |
| 04 | ROM VERSION | AT | Display only | - | - | Displays the ROM version. | - |
| | | PACKAGE | | | | | |

ADVANCED menu

| ADVANCED menu | | | | | | | |
|---------------|-----------|-----------------|----------|-----------------|----------------|--|------|
| No. | Page | Item | Settings | Default setting | USER menu page | Description | File |
| 01 | LOW LIGHT | LOW LIGHT | ON / OFF | ON | - | Turns the LOW LIGHT indication on or off. This indication indicates that the average video level has fallen below a specified threshold. | A |
| | | LOW LIGHT LEVEL | - | 0 | | Sets the threshold for the LOW LIGHT indication. | |
| | | BATTERY | 10 / 20% | 10% | | Specifies the remaining battery level that triggers a flashing display in the viewfinder. | |

| ADVANCED menu | | | | | | | |
|---------------|-----------------|-----------------|-------------------------------------|-----------------|----------------|---|------|
| No. | Page | Item | Settings | Default setting | USER menu page | Description | File |
| 02 | AUTO IRIS | IRIS OVER RIDE | ON / OFF | ON | - | Turns the auto iris override function on or off. | A |
| | | IRIS SPEED | (-99 to +99) | 0 | | Sets the auto iris speed. | |
| | | CLIP HIGH LIGHT | ON / OFF | OFF | | Turns on and off the function which, when auto iris is on, dampens the reaction to high luminance by detecting and clipping high-luminance areas. | |
| | | IRIS LEVEL | - | 0 | | Adjusts the auto iris target level. | |
| | | IRIS APL RATIO | | | | Adjusts the mix ratio between auto iris detected peaks and average values. | |
| 03 | SW STATUS | GAMMA | ON / OFF | ON | - | Turns the gamma correction function on or off. | A |
| | | MATRIX | | | | Turns the linear matrix correction function on or off. | |
| | | KNEE | | | | Turns knee correction on or off. | |
| | | WHITE CLIP | | | | Turns white clipping correction on or off. | |
| | | DETAIL | | | | Turns detail correction on or off. | |
| | | APERTURE | | | | Turns aperture correction on or off. | |
| | | FLARE | | | | Turns flare correction on or off. | |
| 04 | BLACK/ FLARE | MASTER BLACK | - | 0 | - | Adjusts the master black level. | A |
| | | R BLACK | (-99 to +99) | | | Adjusts the R black level. | |
| | | B BLACK | | | | Adjusts the B black level. | |
| | | MASTER FLARE | | | | Adjusts the master flare level. | |
| | | R FLARE | | | | Adjusts the R flare level. | |
| | | G FLARE | | | | Adjusts the G flare level. | |
| | | B FLARE | | | | Adjusts the B flare level. | |
| | | FLARE | ON / OFF | ON | | Turns flare correction on or off. | |
| 05 | GAMMA | GAMMA | ON / OFF | ON | - | Turns gamma correction on or off. | A |
| | | STEP GAMMA | 0.35 to 0.90 | 0.45 | | Sets the step gamma correction curve. | |
| | | MASTER GAMMA | (-99 to +99) | 0 | | Sets the master gamma correction curve. | |
| | | R GAMMA | | | | Sets the R gamma correction curve. | |
| | | G GAMMA | | | | Sets the G gamma correction curve. | |
| | | B GAMMA | | | | Sets the B gamma correction curve. | |
| | | GAMMA SELECT | STD / CINE1 / CINE2 / CINE3 / CINE4 | STD | | Selects a master gamma correction curve. | |
| | | KNEE FIX(CINE) | ON / OFF | ON | | When GAMMA SELECT is set to CINE1, CINE2, CINE3, or CINE4, turns fixed knee point on or off. | |

| ADVANCED menu | | | | | | | |
|---------------|---------------|----------------------|---------------------|--|----------------|---|------|
| No. | Page | Item | Settings | Default setting | USER menu page | Description | File |
| 06 | DETAIL | DETAIL | ON / OFF | ON | - | Turns detail correction on or off. | A |
| | | CRISPENING | - | 0 | | Sets the crispening level. | |
| | | LEVEL DEPEND | ON / OFF | ON | | Turns the level depend function on or off. | |
| | | DETAIL FREQUENCY | - | 0 | | Sets the H detail signal frequency. | |
| | | APERTURE | ON / OFF | ON | | Turns aperture correction on or off. | |
| | | APERTURE LEVEL | - | 0 | | Sets the aperture level. | |
| | | KNEE APT LEVEL | | | | Sets the knee aperture level. | |
| | | DETAIL LIMIT | | | | Sets the detail limiter level. | |
| 07 | SD DETAIL | SD DTL LEVEL-MID | - | 0 | - | Sets the SD detail level (MID). | A |
| | | SD CRISPENING | | | | Sets the SD crispening level. | |
| | | SD DTL LIMIT | | | | Sets the SD detail limiter level. | |
| | | SD LEVEL DEPEND | | | | Sets the SD level depend level. | |
| | | SD DTL FREQUENCY | (-99 to +99) | Sets the SD H detail signal frequency level. | | | |
| | | SD DTL H/V RATIO | - | Sets the SD V detail ratio. | | | |
| | | SD CROSS COLOR | | Sets the amount of SD cross color suppression. | | | |
| 08 | WHITE SHADING | WHITE SHADING CH SEL | R / G / B / TEST | R | - | Selects the channel adjusted with this menu. If TEST is selected with the output signal selector switch (button) of a remote control unit, the setting matches that of VIDEO OUT SEL. | A |
| | | VIDEO OUT SEL | VBS / R / G / B / Y | VBS | | Selects the signal output from the VIDEO OUT connector. | |
| | | R WHT H SAW | (-99 to +99) | 0 | | H SAW white shading correction | |
| | | R WHT H PARA | | | | H PARA white shading correction | |
| | | R WHT V SAW | | | | V SAW white shading correction | |
| | | R WHT V PARA | | | | V PARA white shading correction | |
| | | WHITE SAW/PARA | ON / OFF | ON | | Turns white shading SAW/PARA correction on or off. | |

| ADVANCED menu | | | | | | | |
|---------------|---------------|----------------------|---|-----------------|---------------------------------|--|------|
| No. | Page | Item | Settings | Default setting | USER menu page | Description | File |
| 09 | BLACK SHADING | BLACK SHADING CH SEL | R / G / B / TEST | R | – | Selects the channel adjusted with this menu. If TEST is selected with the output signal selector switch (button) of a remote control unit, the setting matches that of VIDEO OUT SEL. | A |
| | | VIDEO OUT SEL | VBS / R / G / B / Y | VBS | | Selects the signal output from the VIDEO OUT connector. | |
| | | R BLK H SAW | (–99 to +99) | 0 | | H SAW black shading correction | |
| | | R BLK H PARA | | | H PARA black shading correction | | |
| | | R BLK V SAW | | | V SAW black shading correction | | |
| | | R BLK V PARA | | | V PARA black shading correction | | |
| | | BLACK SAW/PARA | ON / OFF | ON | | Turns black shading SAW/PARA correction on or off. | |
| | | MASTER BLACK | – | 0 | | Adjusts the master black level. | |
| | | MASTER GAIN(TMP) | –3 / 0 / 3 / 6 / 9 / 12 / 18 / 24 / 30 / 36 / 42 dB | 0dB | | Temporarily adjusts the master gain value. | |
| 10 | DCC | DCC D RANGE | 200% to 460% | 460% | – | Sets the dynamic range applied when DCC is on. | A |
| | | DCC POINT | – | 0 | | Adjusts the DCC minimum knee point. | |
| | | DCC GAIN | (–99 to +99) | | | Adjusts the gain vs. the DCC detected value. | |
| | | DCC DELAY TIME | – | | | Adjusts DCC reaction speed. | |
| 11 | ND COMP | ND OFFSET ADJUST | ON / OFF | OFF | – | Turns ND offset adjustment mode on or off. This mode is for adjusting the offset for color correction by the ND filter. <i>See “Setting the Amount of Compensation for Color Casts by ND Filters” (page 141).</i> | A |
| | | CLEAR ND OFFSET | – | EXEC | | Clears the ND filter color correction offset. <i>See “Setting the Amount of Compensation for Color Casts by ND Filters” (page 141).</i> | |

Displaying Menu

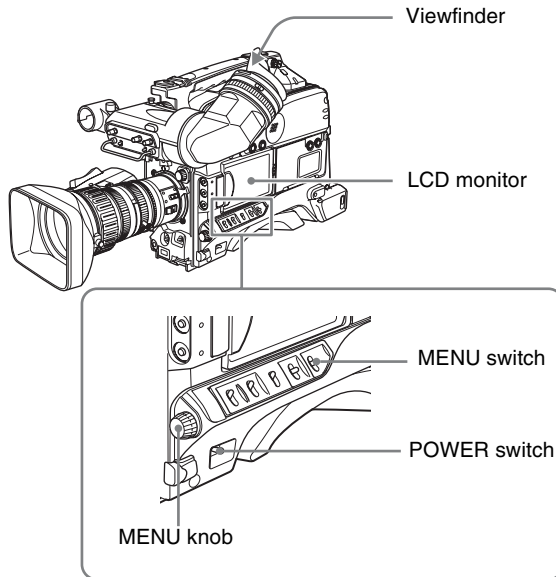

When the camcorder is powered on, flick the MENU switch to the ON position to display the menu on the viewfinder screen and the LCD monitor.

If this is the first time the menu has been used after the camcorder has been powered on, the USER menu is displayed. If the menu has been used before, the last accessed page appears.

When the menu is not displayed on the LCD monitor

Press the DISPLAY/EXPAND button at the lower left of the LCD monitor to select the CHAR display.

To clear the menu display from the screen

Flick the MENU switch to OFF.

When the DISPLAY switch on the viewfinder is set to ON, the display indicating the current status of the camcorder appears on the viewfinder screen.

For details, see “Selecting the Display Items” on page 135.

To display the TOP menu

With no menu displayed on the screen, hold down the MENU knob and flick the MENU switch to the ON position.

menu display, but a similar display also appears on the viewfinder screen.

To select the setting items and values on the menu

Turn the MENU knob to select in the cases explained below.

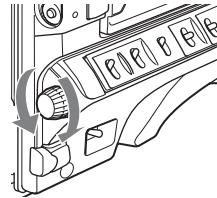

To scroll pages

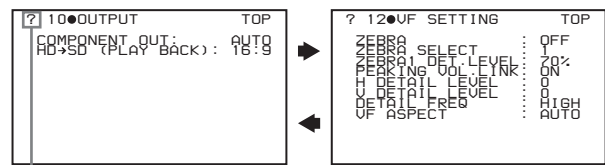

When ? blinks, turn the MENU knob to switch pages.

To select a menu or setting item

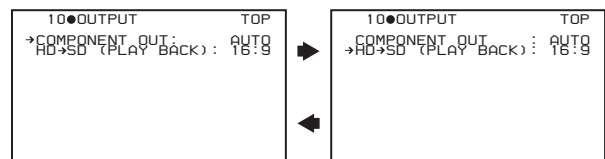

When → appears, turn the MENU knob to move → up and down.

To change a setting value

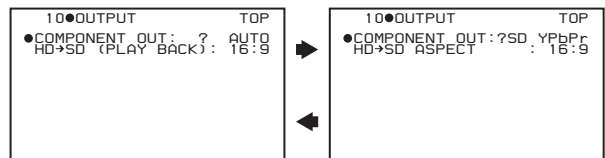

When ? blinks, turn the MENU knob to change the setting (ON/OFF, value, etc.).

Basic Menu Operations

By pressing and turning the MENU knob, you can set various menu items. In the remainder of this section, the LCD monitor is generally shown as an example of the

To confirm the selection of a menu, a setting item, or a setting value

Each time you press the MENU knob, the menu display switches in the following sequence.

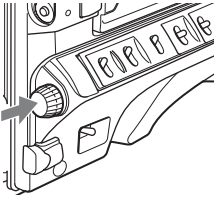

Example: When using the OPERATION menu

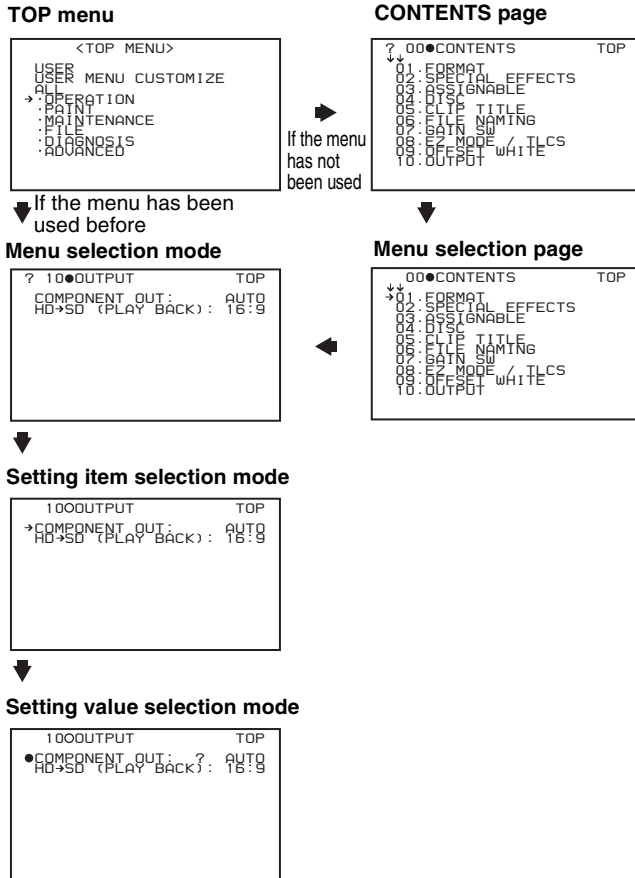

Note

If the TOP menu has not been displayed since the camcorder is powered on, "TOP" does not appear at the upper right on the above screen, and you cannot go to the TOP menu. In this case, follow the procedure in "To display the TOP menu when another menu is displayed" on page 130.

To display the TOP menu when another menu is displayed

Move \blacktriangleright to "TOP" displayed at the top right of each page of the menu, and press the MENU knob. Or flick the MENU switch repeatedly to ON until the TOP menu is displayed.

Using the USER Menu (Example Menu Operation)

This section explains menu operations using the USER menu as an example. The operations are the same for the ALL, OPERATION, PAINT, MAINTENANCE, FILE, DIAGNOSIS, and ADVANCED menus. For details about how to operate the USER MENU CUSTOMIZE menu, see "Editing the USER Menu" on page 132.

1 Flick the MENU switch to ON.

Normally, the USER menu appears.

If it does not, turn the MENU knob to move \blacktriangleright to USER in the TOP menu, and press the MENU knob. If the USER menu has been used before, the last accessed page appears. In this case, go to step 2. If this is the first time the USER menu has been displayed, the CONTENTS page of the USER menu appears. In this case, follow the procedure below.

- Press the MENU knob. Then turn the MENU knob to move \blacktriangleright to the desired page number.

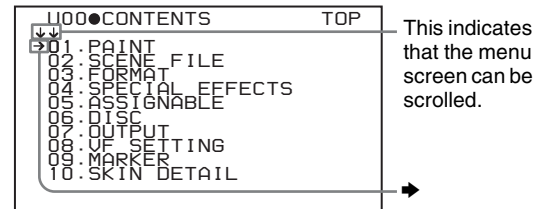

- Press the MENU knob again. The page selected in ① is displayed. Go to step 3.

When you set items on the ALL, OPERATION, PAINT, MAINTENANCE, FILE, DIAGNOSIS, and ADVANCED menu, move \blacktriangleright to the menu that contains the desired item in the TOP menu, and then press the MENU knob.

2 Turn the MENU knob until the desired page appears.

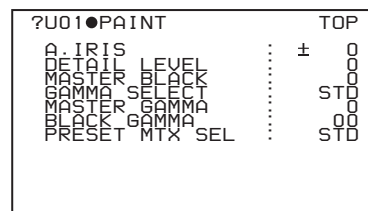

- Press the MENU knob. \blacktriangleright and \bullet appear.

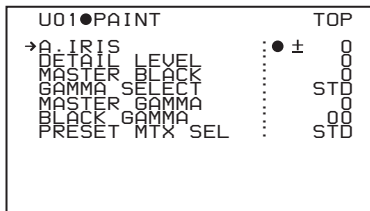

4 Turn the MENU knob to move ➔ to the desired item, and then press the MENU knob.

➔ changes to ●, and ● changes to ?.

5 Turn the MENU knob to change the setting.

Depending on the direction of turning the knob, the setting value increases, decreases, switches between ON and OFF, and so on.

If you want to cancel a change or return to the standard settings, see the items below “To interrupt changing the settings” and “To return to the factory default settings”.

To interrupt changing the settings

Flick the MENU switch to OFF.

By flicking the MENU switch to ON again, the values that were displayed when you interrupted the setting operations will reappear so you can continue making settings.

6 Press the MENU knob.

● changes to ➔, and ? changes to ●. The selection is confirmed.

7 To continue setting other items on the same page, repeat steps from **4** to **6**.

8 To end the menu operation, flick the MENU switch to OFF.

The menu disappears from the screen, and the display indicating the current status of the camcorder appears along the top and bottom of the screen.

To return to the factory default settings

The settings return to the factory default values if the MENU knob is pressed and held in step **5** of the above procedure.

To move to another page

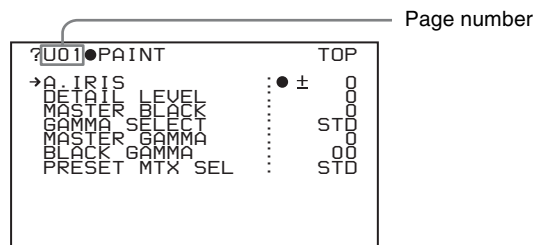

When ? appears in front of the page number

Turn the MENU knob to switch pages.

When nothing appears in front of the page number

Turn the MENU knob to move ➔ to the page number, and press the MENU knob. Then turn the MENU knob to switch pages.

Editing the USER Menu

The USER MENU CUSTOMIZE menu allows you to configure a USER menu that consists only of pages and items that you need by adding, deleting or replacing the pages.

To add a new page

The USER MENU CUSTOMIZE menu allows you to add a new page to the USER menu.

While the EDIT page contains factory-preset items, the USER 1 EDIT to USER 19 EDIT pages are all blank in their initial state. You can register up to 10 items, including blank lines, on each of these pages.

(How to select an item in the menu screen: Turn the MENU knob to move the ➔ mark to the desired item.)

1 Display the TOP menu (*see page 130*).

2 Select USER MENU CUSTOMIZE, and press the MENU knob.

If this is the first time the USER MENU CUSTOMIZE menu has been displayed, the CONTENTS page of the menu appears.

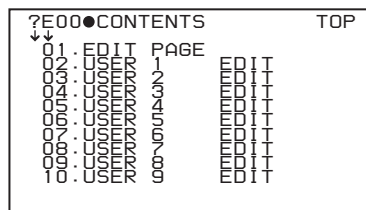

If the USER MENU CUSTOMIZE menu has been used before, the last accessed page appears.

- 3** If the CONTENTS page is displayed, press the MENU knob. Then select one of USER 1 EDIT to USER 19 EDIT, and press the MENU knob. If a different page is displayed, turn the MENU knob until the desired page appears, then press the MENU knob.

Example: When the USER 9 EDIT page is selected

```
E100USER 9 EDIT      TOP
→
```

- 4** Press the MENU knob. Then select the line where you want to add an item, and press the MENU knob.

The EDIT FUNCTION page appears.

```
EDIT FUNCTION      ESC
→INSERT
MOVE
DELETE
BLANK
```

- 5** Select INSERT, and press the MENU knob.

The following menu appears.

```
?P00●CONTENTS      ESC
01.SPECIAL EFFECTS
02.DSIGNABLE
03.DISC
04.CLIP TITLE
05.FILE NAMING
06.GAIN SW
07.FZ MODE/TLCS
08.OFFSET WHITE
09.OUTPUT
10.VIDEO OUT
```

- 6** Add the items as follows.

- ① Press the MENU knob, scroll the page until the desired item appears, and then press the MENU knob again.
- ② Press the MENU knob again, select the desired item, and then press the MENU knob once more.

The USER 9 EDIT page appears again, displaying the newly added item.

- 7** Repeat steps **4** to **6** to add the remaining items.

You can add up to 10 items on one page.

To delete items on a page

- 1** Follow steps **1** to **3** in “To add a new page” on page 132.
- 2** Press the MENU knob. Then select the item that you want to delete, and press the MENU knob.

The EDIT FUNCTION page appears.

- 3** Select DELETE, and press the MENU knob.

The previously displayed page appears again, and the message “DELETE OK? YES → NO” appears at the upper right.

- 4** To delete, select YES, and press the MENU knob.

To replace items on a page

- 1** Follow steps **1** to **3** in “To add a new page” on page 132.
- 2** Press the MENU knob. Then select the item that you want to replace, and press the MENU knob.

The EDIT FUNCTION page appears.

- 3** Select MOVE, and press the MENU knob.

The previously displayed page appears again.

- 4** Select the position to which you want to move the item, and press the MENU knob.

The item selected in step **2** moves to the position that you selected in step **4**.

To insert a blank line

- 1** Follow steps **1** to **3** in “To add a new page” on page 132.
- 2** Press the MENU knob. Then select the item above which you want to insert a blank line, and press the MENU knob.

The EDIT FUNCTION page appears.

- 3** Select BLANK, and press the MENU knob.

The previously displayed page appears again, and a blank line is inserted above the specified item.

Note

You cannot insert a blank line on a page where 10 items have already been registered.

To add/delete/replace pages

You can add a new page to the USER menu, delete a page from the USER menu, or replace pages, using the EDIT PAGE of the USER MENU CUSTOMIZE menu.

To add a page

(How to select an item in the menu screen: Turn the MENU knob to move the **▶** mark to the desired item.)

- 1 Display the TOP menu (*see page 130*).
- 2 Select USER MENU CUSTOMIZE, and press the MENU knob.

If this is the first time the USER MENU CUSTOMIZE menu has been displayed, the CONTENTS page appears. If the menu has been used before, the last accessed page appears.
- 3 If the CONTENTS page is displayed, press the MENU knob. Then select EDIT PAGE, and press the MENU knob.

If a different page is displayed, turn the MENU knob until the EDIT PAGE screen appears.

The EDIT PAGE appears.

```
?E01●EDIT PAGE TOP
01.PAINT
02.FORMAT
03.OUTPUT
04.ASSIGNABLE
05.SPECIAL EFFECTS
06.CF SETTING
07.SKIN DETAIL
08.SCENE FILE
09.SUBSET
●●●END OF PAGE●●●
```

- 4 Press the MENU knob. Then select the position where you want to add the page, and press the MENU knob.

The EDIT FUNCTION page appears.
- 5 Select INSERT, and press the MENU knob.

The CONTENTS page appears.
- 6 Select the desired page, and press the MENU knob.

The number and name of the page selected in step **6** is added above the item selected in step **4**.

To cancel adding a page

Before pressing the MENU knob in step **6**, select ESC at the top right of the screen, and press the MENU knob.

The EDIT PAGE screen appears again.

To delete items on a page

- 1 Follow steps **1** to **3** in “To add a page”.

- 2 Press the MENU knob. Then select the page that you want to delete, and press the MENU knob.

The EDIT FUNCTION page appears.

- 3 Select DELETE, and press the MENU knob.

The previously displayed page appears again, and the message “DELETE OK? YES **▶** NO” appears at the upper right.

- 4 Select YES, and press the MENU knob.

To replace a page

- 1 Follow steps **1** to **3** in “To add a page”.
- 2 Press the MENU knob. Then select the page that you want to move, and press the MENU knob.

The EDIT FUNCTION page appears.
- 3 Select MOVE, and press the MENU knob.

The previous screen appears again.
- 4 Select the position to which you want to move the page selected in step **2**, and press the MENU knob.

The page is moved to the position selected in step **4**.

Resetting USER Menu Settings to the Standard Settings

You can return all settings in the USER menu to standard settings.

(How to select an item in the menu screen: Turn the MENU knob to move the **▶** mark to the desired item.)

- 1 Display the USER FILE page of the FILE menu, and press the MENU knob.

For details on menu operations, see “Basic Menu Operations” on page 130.

```
?F01OUSER FILE TOP
USER FILE LOAD :● EXEC
F.ID : ○○○○○○○○○○○○○○○○○○○
USER PRESET : EXEC
CUSTOMIZE RESET : EXEC
```

- 2 Press the MENU knob, then select USER PRESET, and press the MENU knob.

The message “PRESET OK? YES **▶** NO” appears.

```

?F010USER FILE      TOP
PRESET OK?         YES→NO
USER FILE LOAD    : EXEC
USER FILE SAVE    : EXEC
F.ID : 0000000000000000
→USER PRESET      : EXEC
CUSTOMIZE RESET  : EXEC

```

3 Select YES, and press the MENU knob.

The settings for all items in the USER Menu are reset to the standard settings.

Resetting USER Menu Settings to the Factory Default Settings

You can return all settings in the USER menu to the factory default settings.

(How to select an item in the menu screen: Turn the MENU knob to move the **▶** mark to the desired item.)

1 Display the USER FILE page of the FILE menu, and press the MENU knob.

For details on menu operations, see “Basic Menu Operations” on page 130.

```

?F010USER FILE      TOP
USER FILE LOAD    : ● EXEC
USER FILE SAVE    : EXEC
F.ID : 0000000000000000
USER PRESET      : EXEC
CUSTOMIZE RESET  : EXEC

```

2 Press the MENU knob, then select CUSTOMIZE RESET, and press the MENU knob.

The message “RESET DATA OK? YES **▶** NO” appears.

```

?F010USER FILE      TOP
RESET DATA OK?   YES→NO
USER FILE LOAD    : EXEC
USER FILE SAVE    : EXEC
F.ID : 0000000000000000
USER PRESET      : EXEC
→CUSTOMIZE RESET : EXEC

```

3 Select YES, and press the MENU knob.

The settings for all items in the USER menu are reset to the factory default settings.

Setting the Status Display on the Viewfinder Screen and the LCD Monitor

This section explains the menu settings for the display of the viewfinder screen. These settings are also used for the display of the LCD monitor in the same way.

Selecting the Display Items

To select the items to be displayed on the viewfinder screen (with the viewfinder DISPLAY switch set to ON) and the LCD monitor, use the VF DISP 1 and VF DISP 2 pages of the OPERATION menu.

(How to select an item in the menu screen: Turn the MENU knob to move the **▶** mark to the desired item.)

1 Display the VF DISP 1 or VF DISP 2 page of the OPERATION menu, and press the MENU knob.

For details on menu operations, see “Basic Menu Operations” on page 130.

2 Select the desired setting item, and press the MENU knob.

On the VF DISP 1 and VF DISP 2 pages, you can select any of the following items to turn its display on or off.

VF DISP 1 page

| Item | Description |
|--------------------------------|---|
| DISP REC FORMAT | Displays the recording format. |
| DISP BIT RATE | Indication of HQ, SP or LP recording. |
| DISP SYSTEM | System frequency. |
| DISP 16:9 | Aspect ratio indication when recording SD signals. |
| DISP ZOOM ¹⁾ | Zoom position indication. |
| DISP FOCUS ¹⁾ | Focus setting. |
| DISP BATT REMAIN ²⁾ | Displays the battery voltage or battery remaining capacity. |
| DISP REC/PLAY | REC, PLAY, F REV, and F FWD indications. |
| DISP TIME CODE | Displays the timecode. |

1) This item may not appear depending on the mounted lens.
2) When an Anton Bauer battery system or a BP-GL65/GL95 battery pack is installed, the remaining battery power is shown as a percentage value (%) according to the setting of this item.

INT: When one of the above batteries is installed, the remaining power is shown as a percentage value (%) when there is a change in the value or when the power is low.

AUTO: The remaining power is shown as a percentage value (%) when one of the above batteries is installed. Otherwise the voltage (VOLT) is displayed continuously.

VOLT: The voltage (VOLT) is displayed continuously.

VF DISP 2 page

| Item | Description |
|----------------|---|
| DISP 5600K | Displays "5600K". |
| DISP FILTER | Displays types of the ND filter. |
| DISP WHITE | Displays selected white balance memory. |
| DISP GAIN | Displays gain value. |
| DISP SHUTTER | Displays shutter speed and ECS mode. |
| DISP AUDIO | Displays audio level. |
| DISP DISC | Displays remaining disc capacity. |
| DISP IRIS | Lens iris setting indication |
| DISP LOW LIGHT | "LOW LIGHT" indication when the average video level is below a certain threshold. |
| DISP INTERVAL | "INTERVAL TIME" indication during interval recording. |

- 3** Turn the MENU knob to select the desired setting (ON, OFF, or value), and press the MENU knob.
- 4** Repeat steps **2** and **3** until you have set all of the desired items.

Change Confirmation/Adjustment Progress Messages

The messages indicating setting changes, progress and consequence of adjustments, and the situations indicated by these messages are as follows.

Setting change confirmation/adjustment progress messages

| Situation | Message to appear |
|---|---|
| The filter selection has been changed | FILTER: n (where n = 1, 2, 3, 4) |
| The gain setting has been changed | GAIN: n (where n = -3dB, 0dB, 3dB, 6dB, 9dB, 12dB, 18dB, 24dB, 30dB, 36dB, 42dB, 48dB) |
| The setting of the WHITE BAL switch has been changed | WHITE: n (where n = A CH, B CH, PRESET) or ATW: RUN |
| The OUTPUT/DCC switches has been set to DCC ON or OFF | DCC: ON (or OFF) |

| Situation | Message to appear |
|---|---|
| The shutter speed and mode setting has been changed ¹⁾ | SHUTTER: 1/100 (or 1/125, 1/250, 1/500, 1/1000, 1/2000, ECS, SLS) |
| The black or white balance has been adjusted | E.g. WHITE: OK |

1) The corresponding message is also displayed for about 3 seconds when the SHUTTER switch is set to ON.

Setting the Marker Display

You can switch the display of the center and safety zone markers on or off and select whether the area indicated by the safety zone marker is 80%, 90%, 92.5%, or 95% of the screen area.

(How to select an item in the menu screen: Turn the MENU knob to move the ➔ mark to the desired item.)

- 1** Display the MARKER page of the USER (or OPERATION) menu, and press the MENU knob.
For details on menu operations, see "Basic Menu Operations" on page 130.
- 2** Select the desired setting item, and press the MENU knob.

You can set the following items on the MARKER page.

| Item | Description |
|---------------|--|
| MARKER | If you want no markers to be displayed, set to OFF. |
| CENTER | To display the center marker, set to ON. |
| SAFETY ZONE | To display the safety zone, set to ON. |
| SAFETY AREA | Selects the safety zone area. |
| ASPECT | To display the aspect marker, set to ON. |
| ASPECT SELECT | Selects the type of the aspect marker. (14:9/13:9/4:3) |

- 3** Turn the MENU knob to select the desired setting, and press the MENU knob.
- 4** Repeat steps **2** and **3** until you have set all of the desired items.

Setting the Viewfinder Screen Display

You can make settings for viewfinder screen display functions.

(How to select an item in the menu screen: Turn the MENU knob to move the ► mark to the desired item.)

- 1 Display the VF SETTING page of the USER (OPERATION) menu, and press the MENU knob.

For details on menu operations, see “Basic Menu Operations” on page 130.

- 2 Select the desired setting item, and press the MENU knob.

You can set the following items on the VF SETTING page.

| Item | Description |
|------------------|---|
| ZEBRA | Turns the zebra display ON or OFF. ¹⁾ |
| ZEBRA SELECT | Selects ZEBRA 1, ZEBRA 2 or BOTH. |
| ZEBRA 1 DET. LVL | Adjusts the level of the ZEBRA 1 display (30% to 107%). (Factory default setting is 70%.) |
| PEAKING VOL.LINK | For viewfinder image adjustments made with the PEAKING control, switches between linkage (ON) and no linkage (OFF) of peaking adjustment and detail level adjustment. |
| H DETAIL LEVEL | Adjusts the H detail of the viewfinder image. |
| V DETAIL LEVEL | Adjusts the V detail of the viewfinder image. |
| DETAIL FREQ | Turns the VF detail function on or off and adjusts the frequency. (NORM/HIGH) |
| VF ASPECT | Selects the viewfinder aspect ratio (AUTO/4:3). ²⁾ |

1) When you use the viewfinder which is not equipped with a ZEBRA switch, turns the display on or off using this item. When you use the viewfinder with a ZEBRA switch, the switch operation and the operation of this menu are both effective (the most recent operation prevails).

2) When the VF ASPECT item is set to AUTO, this is linked to the setting of the “ASPECT RATIO (DV)” item on the FORMAT page.

- 3 Turn the MENU knob to select the desired setting, and press the MENU knob.
- 4 Repeat steps 2 and 3 until you have set all of the desired items.

Recording Shot Data Superimposed on the Color Bars

You can select which shot data is recorded superimposed on the color bars. You can also select which of the shot IDs (1 to 4) set on the SHOT ID page is recorded superimposed on the picture.

(How to select an item in the menu screen: Turn the MENU knob to move the ► mark to the desired item.)

- 1 Display the SHOT DISP page of the OPERATION menu, and press the MENU knob.

For details on menu operations, see “Basic Menu Operations” on page 130.

- 2 Select the desired setting item, and press the MENU knob.

You can set the following items on the SHOT DISP page.

| Item | Description |
|-------------|--|
| SHOT DATE | Selects whether or not the shot data is superimposed (ON or OFF). |
| DATE MODE | Selects the date display format. (One of Y/M/D, M/D/Y, and D/M/Y) |
| SHOT TIME | Selects whether or not shot time is superimposed (ON or OFF). |
| TIME MODE | Switching time indications to the 12-hour or 24-hour clock |
| SHOT ID SEL | Selects whether or not the shot ID set on the SHOT ID page is superimposed. To carry out superimposed recording, select the SHOT ID number (1 to 4). |

- 3 Turn the MENU knob to select the desired setting (ON, OFF, or value), and press the MENU knob.
- 4 Repeat steps 2 and 3 until you have set all of the desired items.

To carry out superimposed recording

To actually record the items selected for superimposed recording on the SHOT DISP page, set the OUTPUT/DCC switch to BARS, DCC OFF. The items selected for superimposed recording appear on the screen and are recorded superimposed on the color bars.

(Display example: shows case where SHOT DATE is ON.)

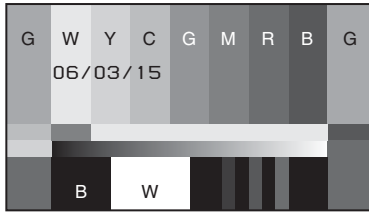

Setting the Shot ID

You can set a shot ID of up to 12 alphanumeric characters, spaces, and symbols. When the OUTPUT/DCC switch is set to BARS, DCC OFF, this shot ID is output with the color bar signal. Four shot IDs are available, ID-1 to ID-4, and you can select the shot ID to be recorded superimposed on the color bars.

Note

When the menu is displayed, the shot ID is not displayed even if the color bar signal is output.

(How to select an item in the menu screen: Turn the MENU knob to move the **▶** mark to the desired item.)

- 1 Display the SHOT ID page of the OPERATION menu, and press the MENU knob.

For details on menu operations, see “Basic Menu Operations” on page 130.

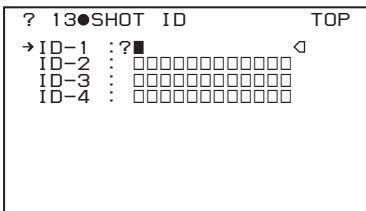

- 2 Select the ID (one of ID-1 to ID-4) you want to set, and press the MENU knob.

■ appears over the first character position in the string, and characters can now be input.

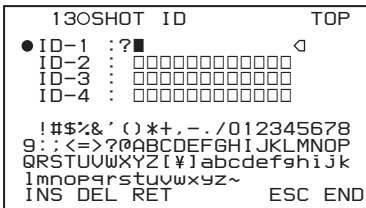

- 3 Enter or change the characters.

When you are entering the shot ID for the first time, go to step ②.

- ① Turn the MENU knob to move ■ to the character which you want to change, then press the MENU knob.

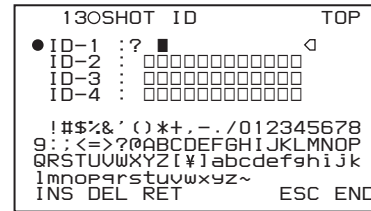

- ② Turn the MENU knob until ■ moves to the character position that you want to select, then press the MENU knob.

Example: When entering the letter “+”

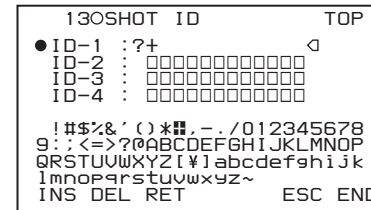

- 4 Repeat step 3 for each of the remaining characters.

- 5 When you have finished character inputting, turn the MENU knob to move ■ over END, then press the MENU knob.

This exits the character input mode, and returns to the SHOT ID page.

To insert a space

In step 3 above, move ■ over INS, and press the MENU knob. To cancel inserting a space, move ■ to RET, and press the MENU knob.

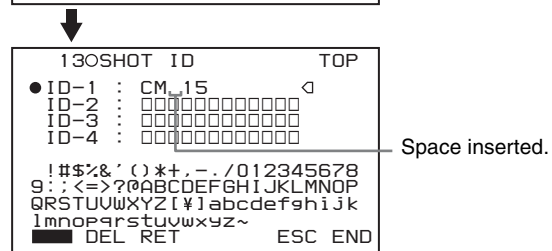
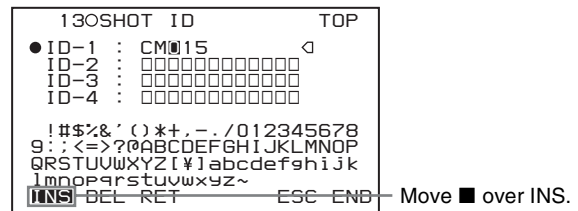

To delete a character

In step 3 of “Setting the Shot ID” on page 138, move ■ over DEL, and press the MENU knob. This deletes the character under ■ in the shot ID row.

To cancel deleting the character, move ■ over RET, and press the MENU knob.

To cancel changing the shot ID

Before executing step 5 of “Setting the Shot ID” on page 138, move ➔ to ESC, and press the MENU knob.

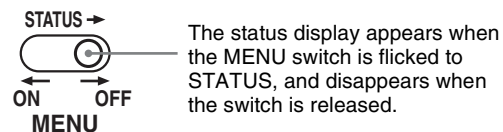
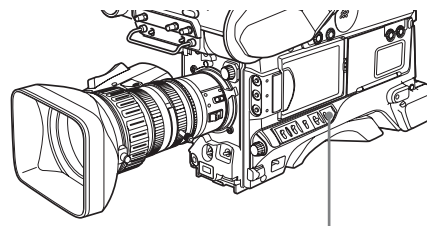

Showing the Status Display

You can confirm the settings or status of the camcorder on the screen by showing the status display.

Items shown in the status display

```

FORMAT : HD 50I SP
WHITE  : 3200K
CLIP CONT REC
ASSIGN <1> EZMOD <2> IRRCN
        <3> OFF <4> OFF

TIME CODE : DF
COMPONENT OUT: HD YPbPr
AUDIO : 16bit 4ch
F.MIC : STEREO
CH1 : FRONT CH2 : REAR
CH3 : FRONT CH4 : FRONT
  
```

The status display allows you to confirm the following items related to camera settings.

- **FORMAT:** Video recording format set on this unit
- **WHITE:** White balance color temperature
- **CLIP CONT REC:** The on/off setting of the Clip Continuous Rec function
- **ASSIGN:** The settings of the ASSIGN 1 to 4 switches
- **TIME CODE:** DF or NDF
- **COMPONENT OUT:** Output from the VIDEO OUT connector
- **AUDIO:** Audio recording format set on this unit
- **F.MIC:** Front microphone setting
- **CH1 to CH4:** Knob adjustment for each audio channel

To show the status display

Flick the MENU switch to STATUS when the menu is not displayed.

Adjustments and Settings from Menus

Setting Gain Values for the GAIN Switch Positions

You can set the gain values for the L, M, and H positions of the GAIN switch, which switches the gain of the video amplifier.

(How to select an item in the menu screen: Turn the MENU knob to move the ► mark to the desired item.)

- 1 Display the GAIN SW page of the OPERATION menu, and press the MENU knob.

For details on menu operations, see “Basic Menu Operations” on page 130.

You can set the following items on the GAIN SW page.

| Item | Description |
|------------|---|
| GAIN LOW | Sets the gain value corresponding to the L position of the GAIN switch. |
| GAIN MID | Sets the gain value corresponding to the M position of the GAIN switch. |
| GAIN HIGH | Sets the gain value corresponding to the H position of the GAIN switch. |
| GAIN TURBO | When assigning TURBO to the ASSIGN switch, sets the gain value corresponding to the ASSIGN switch (see page 143). |

- 2 Select the item corresponding to the switch position, and press the MENU knob.
- 3 Turn the MENU knob to select the gain value, and press the MENU knob.

You can select from -3, 0, 3, 6, 9, 12, 18, 24, 30, 36, 42, and 48 dB.

To change the gain corresponding to another switch position, repeat steps 2 and 3.

Selecting the Output Signals

(How to select an item in the menu screen: Turn the MENU knob to move the ► mark to the desired item.)

- 1 Display the OUTPUT page of the OPERATION menu, and press the MENU knob.

For details on menu operations, see “Basic Menu Operations” on page 130.

- 2 Select COMPONENT OUT, and press the MENU knob.
- 3 Select one of the following, and press the MENU knob.

AUTO: Switch between HD YPbPr and SD YPbPr, according to the recording format. This applies to both recording and playback.

HD YPbPr: Regardless of the recording format, output HD YPbPr when recording. Output SD YPbPr only when playing back DVCAM format.

SD YPbPr: Regardless of the recording format, output SD YPbPr. This applies to both recording and playback.

Setting the Color Temperature Manually

You can manually adjust the value of the white balance by setting the color temperature.

(How to select an item in the menu screen: Turn the MENU knob to move the ► mark to the desired item.)

- 1 Display the WHITE page of the PAINT menu, and press the MENU knob.

For details on menu operations, see “Basic Menu Operations” on page 130.

- 2 Select the desired setting item, and press the MENU knob.

You can set the following items on the WHITE page.

| Item | Description |
|----------------|---|
| COLOR TEMP <A> | Sets the color temperature for the desired value. Adjust the value while looking at the real image because error tends to be bigger for adjustment of high color temperature. |
| C TEMP BAL <A> | Adjusts the value more precisely when the color temperature adjustment through COLOR TEMP is not satisfactory. |
| R GAIN <A> | Changes only the value of R GAIN. |
| B GAIN <A> | Changes only the value of B GAIN. |

| Item | Description |
|-----------|---|
| D5600K<A> | Sets the color temperature to approximately 5600K |

The above table shows the adjustment of the white balance of channel A. Items followed by are used to adjust the white balance of channel B.

- Turn the MENU knob to select the desired setting, and press the MENU knob.
- Repeat steps 2 and 3 until you have set all of the desired items.

Specifying an Offset for the Auto White Balance Setting

By setting an offset for the value of auto white balance, you can make the picture warmer or colder.

(How to select an item in the menu screen: Turn the MENU knob to move the ➔ mark to the desired item.)

- Display the OFFSET WHITE page of the OPERATION menu, and press the MENU knob.

For details on menu operations, see “Basic Menu Operations” on page 130.

- Select the desired setting item, and press the MENU knob.

You can set the following items in the OFFSET WHITE page.

| Item | Description |
|------------------|---|
| OFFSET WHITE <A> | When this item is set to ON, the offset adjusted on this page is added to the white balance for channel A. |
| WARM-COOL <A> | When OFFSET WHITE <A> is ON, sets the offset for the white balance of channel A, using the color temperature. Adjust the value while looking at the real image because error tends to be bigger for adjustment of high color temperature. |
| COLOR FINE <A> | Adjusts the value more precisely if the adjustment by WARM-COOL <A> is not satisfactory. |
| OFFSET WHITE | When this item is set to ON, the offset adjusted on this page is added to the white balance for channel B. |

| Item | Description |
|----------------|---|
| WARM-COOL | When OFFSET WHITE is ON, sets the offset for the white balance of channel B, using the color temperature. Adjust the value while looking at the real image because error tends to be bigger for adjustment of high color temperature. |
| COLOR FINE | Adjusts the value more precisely if the adjustment by WARM-COOL is not satisfactory. |

- Set the WHITE BAL switch to the channel (A or B) that you want to set.

Note

If the WHITE BAL switch is not set to A or B, the adjusted value is not reflected in the video output even though you carry out the following operation.

- Turn the MENU knob to perform the settings for each item, and press the MENU knob.

If you want to set the other channel, go back to step 2.

Setting the Amount of Compensation for Color Casts by ND Filters

The internal ND filters are almost color neutral, but there is a slight color cast for each filter. This can cause the white balance to shift when you change the position of the FILTER selector.

The ND COMP function compensates for this automatically by memorizing a color offset for each filter. Note that these offset values are adjusted correctly when the unit is shipped from the factory. Normally you should not need to carry out the following procedure.

To set the amount of compensation for color casts

- Shoot a gray scale or white test card and zoom up so that it fills the screen.
- Set the FILTER selector to position 4, and adjust the lighting so that “OK” appears when the white balance is adjusted.
- Display the ND COMP page of the ADVANCED menu, and then press the MENU knob.

For details on menu operations, see “Basic Menu Operations” on page 130.

- 4 Set ND OFFSET ADJUST to ON.
- 5 Set the FILTER selector to position 1, and adjust the iris and white balance, either automatically or by manual adjustments.
- 6 Check that “ND1:OK” appears when the adjustments finish.
- 7 Set the FILTER selector to position 2, and adjust the iris and white balance, either automatically or by manual adjustments.
- 8 Check that “ND2:OK” appears when the adjustments finish.
- 9 Repeat step 5 with the FILTER selector set to positions 3 and 4.
- 10 When “ND COMPLETE!” appears, and the displays for each ND filter have changed to “ND1:OK”, “ND2:OK”, “ND3:OK”, and “ND4:OK”, set the POWER to OFF.

Note

When you set the POWER switch to ON again and display the ND COMP page, ND OFFSET ADJUST will be OFF.

Although the ND OFFSET ADJUST item is OFF, the offset settings that you specified will be memorized and the compensation function will be working. Set the ND OFFSET ADJUST item to ON again if you want to specify new offset settings.

To clear the color cast compensation settings

- 1 Display the ND COMP page of the ADVANCED menu, and then press the MENU knob.
For details on menu operations, see “Basic Menu Operations” on page 130.
- 2 Select CLEAR ND OFFSET, and then press the MENU knob.
- 3 When the message “CLEAR DATA OK? YES → NO” appears, select YES and press the MENU knob.
- 4 When the message “COMPLETE!” appears, set the POWER switch to OFF.

Selecting Gamma Tables

You can select gamma curves from among five preset patterns, for times when you want to achieve film-like gradations and color reproduction and other effects.

- 1 Display the PAINT page of the PAINT menu, and then select GAMMA SELECT and press the MENU knob.

For details on menu operations, see “Basic Menu Operations” on page 130.

- 2 Select the desired item and press the MENU knob.

The following settings are available.

| Item | Description |
|-------|---|
| STD | Standard setting (factory default setting) |
| CINE1 | This smooths the contrasts in darker sections and accentuates gradation changes in brighter sections, for a calm and quiet effect. |
| CINE2 | This gives almost the same results as CINE1. Select this when you want to obtain 100% video signals for editing or other purposes. |
| CINE3 | This emphasizes the contrast between light and dark more than CINE1 and CINE2, and also accentuates gradation changes on the black side. |
| CINE4 | This emphasizes the contrast in dark section even more than CINE3. Contrasts in darker sections are weaker than STD, and contrasts in brighter sections are stronger. |

Note

When you select CINE1 to CINE4, the knee point is fixed at a preset value and cannot be adjusted, even if you set KNEE on the SW STATUS page of the PAINT menu to ON. DCC is also disabled.

Making Low-Noise mode Settings

Low-noise mode allows you to obtain clear video with little noise under low light conditions.

- 1 Select LOW NOISE MODE on the CAM CONFIG page of the MAINTENANCE menu, and then press the MENU knob.

For details on menu operations, see “Basic Menu Operations” on page 130.

- 2 Select the desired item and press the MENU knob.

You can make the following settings.

| Item | Description |
|------|--|
| OFF | Standard setting (factory default setting) |

| Item | Description |
|------|---|
| 1 | Reduce noise by using the noise reduction circuits, without lowering the sensitivity. Resolution and gradations under low light are slightly lower. |
| 2 | Reduce noise more than the 1 setting by lowering the sensitivity. Compared to the OFF setting, sensitivity is about 20% lower, and the dynamic range is about 20% lower. (Sensitivity declines to about F8, compared to the standard F9.) |

Assigning Functions to ASSIGN Switches

You can assign the desired function to any of the ASSIGN switches.

(How to select an item in the menu screen: Turn the MENU knob to move the ► mark to the desired item.)

- 1 Display the ASSIGNABLE page on the OPERATION menu, and press the MENU knob.

For details on menu operations, see “Basic Menu Operations” on page 130.

You can assign functions by using the following items.

| Item | Description |
|---------------|--|
| ASSIGN SW <1> | Assigns the function to ASSIGN 1 switch. |
| ASSIGN SW <2> | Assigns the function to ASSIGN 2 switch. |
| ASSIGN SW <3> | Assigns the function to ASSIGN 3 switch. |
| ASSIGN SW <4> | Assigns the function to ASSIGN 4 switch. |

- 2 Select the desired ASSIGN switch (ASSIGN SW <1> to <4>), and press the MENU knob.

The corresponding ASSIGN SW (1 to 4) SEL window appears. You can assign one of the following functions to the ASSIGN switch.

| Function | Description |
|------------|---|
| OFF | Assign no function. |
| MARKER | Turn the display of all markers on or off. ^{a)} |
| RETAKE | Delete the last recorded clip. (This function is disabled when the Clip Continuous Rec function is on.) |
| ATW | Turn ATW on or off. |
| LENS RET | Use the recording review function. |
| REC SWITCH | Start/stop recording. |

| Function | Description |
|--------------------------------------|--|
| TURBO SWITCH | Use the gain value set for GAIN TURBO (see page 140). |
| ZOOM TELE/ WIDE | Sets ASSIGN SW<3> to lens zoom TELE, and ASSIGN SW<4> to lens zoom WIDE. (ASSIGN SW<1> and ASSIGN SW<2> cannot be assigned to zoom.) |
| ZOOM WIDE/ TELE | Sets ASSIGN SW<3> to lens zoom WIDE, and ASSIGN SW<4> to lens zoom TELE. (ASSIGN SW<1> and ASSIGN SW<2> cannot be assigned to zoom.) |
| FREEZE MIX | Output the freeze image and camera input alternately, to allow frame alignment (automatic switching). |
| SHOT MARK1 | Use the shot mark 1 function. |
| SHOT MARK2 | Use the shot mark 2 function. |
| EZ MODE ^{b)} | Turn EZ mode on or off. |
| EZ FOCUS ^{b)} | Turn the EZ focus function on or off. |
| SKIN DETAIL ON/ OFF ^{b)} | Turn the skin detail adjustment function on or off. |
| SPOT LIGHT ^{b)} | Use auto iris spotlight mode ^{d)} |
| BACK LIGHT ^{b)} | Use auto iris backlight mode ^{e)} |
| TLCS ^{b), c)} | Enter or exit TLCS mode. |
| PICTURE CACHE | Turn the Picture Cache function on or off. |
| AWB | Execute the auto white balance function. |
| SHUTTER SW | Turn the shutter on or off. |
| SHUTTER MODE | Execute shutter mode switching and shutter speed switching. |
| CLIP CONT REC | Turn the Clip Continuous Rec function on or off. |

a) Even when the MARKER item is set to OFF on the MARKER page of the OPERATION menu, the ASSIGN switches allow you to turn the display of all markers on or off.

b) Function assignable to ASSIGN 1 and ASSIGN 2 switches only

c) Abbreviation for Total Level Control System. A function to operate the automatic gain control (AGC) and electronic shutter (AE) to adapt to varying lighting conditions while shooting.

d) Use when shooting a subject at which a spotlight is directed.

e) Use when shooting a backlit subject.

- 3 Select the desired function, and press the MENU knob.

The function is assigned, and the ASSIGNABLE page appears again.

Selecting the Lens File

You can change the lens file according to the lens in use.

- 1 Display the LENS FILE page of the FILE menu, and press the MENU knob.

For details on menu operations, see “Basic Menu Operations” on page 130.

The LENS FILE page shows the name and the iris setting value of the lens currently selected.

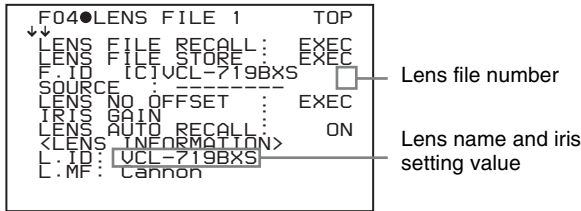

- 2 Select LENS AUTO RECALL, and press the MENU knob.
- 3 Select ON, and press the MENU knob.

Selecting the Aspect Ratio

Switching the aspect ratio for DVCAM recording

You can switch the aspect ratio for DVCAM recording.

(How to select an item in the page screen: Turn the MENU knob to move the ► mark to the desired item.)

- 1 Display the FORMAT page of the USER (or OPERATION) menu, and press the MENU knob.

For details on menu operations, see “Basic Menu Operations” on page 130.

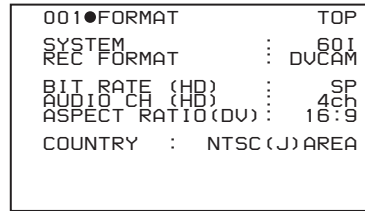

- 2 Select ASPECT RATIO (DV), and press the MENU knob.
- 3 Turn the MENU knob to select the desired aspect ratio (16:9/4:3), and press the MENU knob.

Setting the aspect ratio in HD mode

You can select the aspect ratio of video downconverted from HD for output as SD.

(How to select an item in the menu screen: Turn the MENU knob to move the ► mark to the desired item.)

- 1 Display the OUTPUT page of the OPERATION menu, and press the MENU knob.
- 2 Select HD→SD, and press the MENU knob.
- 3 Turn the MENU knob to select the desired aspect ratio (16:9/4:3), and press the MENU knob.

Note

The aspect ratio of HD analog composite output is always 16:9.

To display a “16:9” aspect ratio of on the viewfinder screen

When the recording format is DVCAM and the aspect ratio is 16:9, you can display the indication “16:9” on the viewfinder screen by setting DISP 16:9 on the VF DISP 1 page of the OPERATION menu to ON.

For details, see “Selecting the Display Items” on page 135.

About the CCD Scan Mode

This unit allows you to record in progressive scan mode as well as in interlace scan mode. You can select the scan mode from the following modes using the FORMAT page of the OPERATION menu.

- 60i (interlace scan) mode
- 30P (progressive scan) mode
- 23.98P mode

Pulldown method for DVCAM format recording in 23.98P mode

DVCAM video signals recorded in 23.98P mode are 2-3 pulled down, and recorded on a disc as 60i signals.

| DF/NDF | Purpose | Notes |
|--------|---|--|
| DF | Obtain an effect similar to that obtained by 23.98P shooting while maintaining interlace scan mode. | — |
| NDF | Re-convert to 23.98P with nonlinear editing software (NLE). (Select according to your NLE.) | <ul style="list-style-type: none"> There will be noise on the recorded image if you change the operating mode for the internal timecode generator using the F-RUN/SET/R-RUN switch on the side control panel while recording. The video and audio signal and timecode output via i.LINK may not be consecutive when recording starts. <p>Notes on 2-3 pulldown</p> <ul style="list-style-type: none"> When the PRESET/REGEN/CLOCK switch on the side control panel is set to CLOCK, this unit operates in DF mode. The synchronization of the timecode and the pulled-down picture is disabled. When drop-frame timecode is input via the TC IN connector, this unit operates in DF mode and synchronization of the pulled-down picture and the timecode is disabled. This setting will continue in effect until the timecode setting (F-RUN/R-RUN or DF/NDF) is changed. |

2-3 pulldown in 23.98P mode

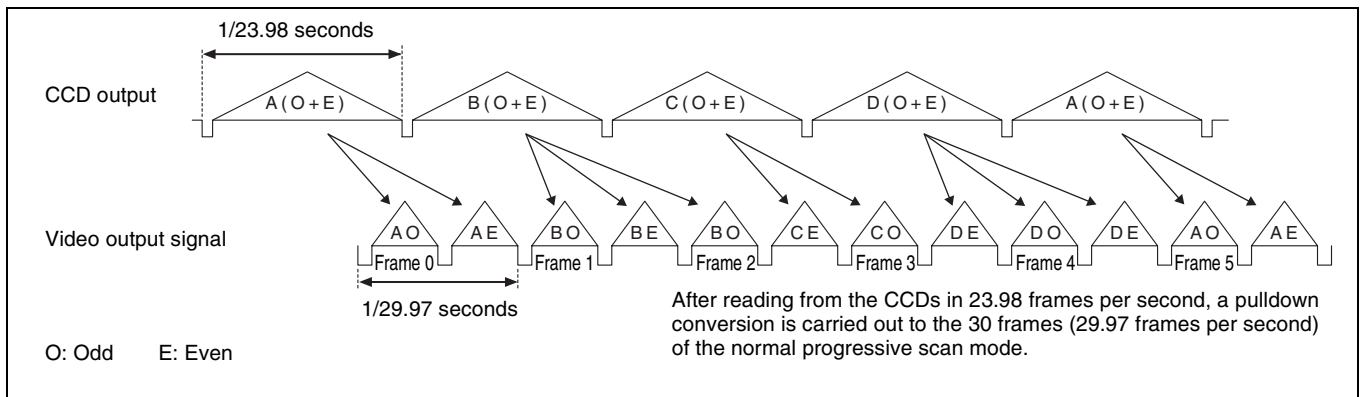

Saving and Loading User Files

The camcorder is equipped with a “Memory Stick” slot, which enables you to save the settings in the USER menu as a user file onto the “Memory Stick”. You can load these files from the “Memory Stick” for immediate recall of a particular setting configuration. In addition to user files, you can save scene files, lens files and ALL files in a “Memory Stick”.

When a menu is displayed, you can set up the camcorder so that inserting a “Memory Stick” automatically jumps to the appropriate file-related menu page.

For details about scene files, see “Saving and Loading Scene Files” on page 150.

For details about lens files and ALL files, see “Menu List” on page 107.

Handling the “Memory Stick”

The “Memory Stick” can be inserted to or removed from the camcorder with the power turned on or off.

“Memory Stick” usable with this camcorder

With this camcorder, you can use a Sony “Memory Stick” whose capacity does not exceed 128 MB, and a Sony “Memory Stick PRO” whose capacity does not exceed 2 GB.

For details, see “About a “Memory Stick”” on page 178.

To insert a “Memory Stick”

- 1 Open the “Memory Stick” slot cover on the back of the camcorder.

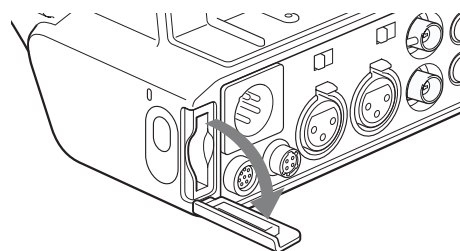

- 2 Insert the “Memory Stick” with its label side facing the “Memory Stick” logo on the camcorder.

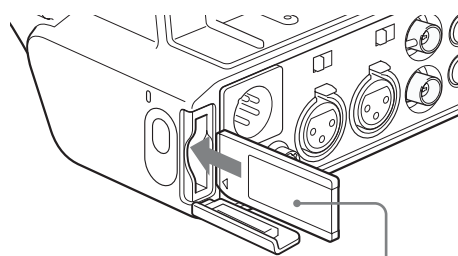

Label side of “Memory Stick”

Note

If it does not fit into the slot properly or if there is some resistance when you insert it, the “Memory Stick” may be turned around or upside down. Do not force the “Memory Stick” into the slot. Confirm the direction of the notch and arrow on the “Memory Stick” before inserting the “Memory Stick”, and then try inserting it again.

To remove the “Memory Stick”

- 1 Check that the access indicator is not lit, then gently press in the “Memory Stick” once and release.

The “Memory Stick” pops out.

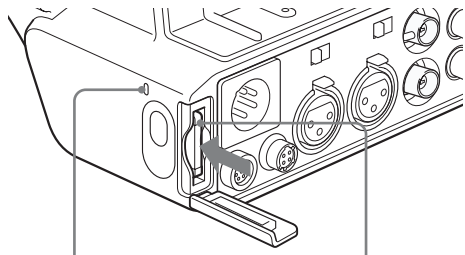

Check that the access indicator is not lit.

Gently press in and release.

- 2 Pull the “Memory Stick” towards you to withdraw it from the slot.

Note

Do not remove the “Memory Stick” while the access indicator is lit. You may lose data, or damage the “Memory Stick”.

To protect saved data

To prevent accidental erasure of important setup data, slide the LOCK switch on the “Memory Stick” right to the write protect position.

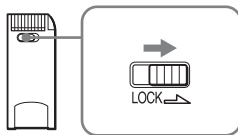

It is now impossible to write or delete data on the “Memory Stick”. If you try to do so, the message “MEMORY STICK LOCKED” appears and the data cannot be overwritten or deleted.

Notes on using and storing the “Memory Stick”

To use and store the “Memory Stick”, note the following points.

- Avoid touching the connector of the “Memory Stick” or contacting it with a metal object.
- When attaching a label to the “Memory Stick”, use only the label supplied for the “Memory Stick”.
- Do not drop, bend, or submit the “Memory Stick” to external shock.
- Do not disassemble or modify the “Memory Stick”.
- Avoid getting liquids on the “Memory Stick”.
- Avoid using or storing the “Memory Stick” in a location subject to:
 - extremely high temperature such as the hot inside of a car or the outdoors exposed to a burning sun, or a place near a heater.
 - direct sunlight.
- When storing and carrying the “Memory Stick”, keep it in its original case to ensure protection of important data.

- Do not format the “Memory Stick” using a PC. Format the “Memory Stick” on the MEMORY STICK page of the FILE menu.

Saving USER Menu Data (User File) to the “Memory Stick”

USER menu settings stored in the camcorder as user files can be saved to the “Memory Stick”.

You can save up to 100 user files to the “Memory Stick”. Insert the “Memory Stick” into the “Memory Stick” slot, then proceed as follows.

(How to select an item in the menu screen: Turn the MENU knob to move the ➔ mark to the desired item.)

- 1 Display the USER FILE page of the FILE menu, and press the MENU knob.

For details on menu operations, see “Basic Menu Operations” on page 130.

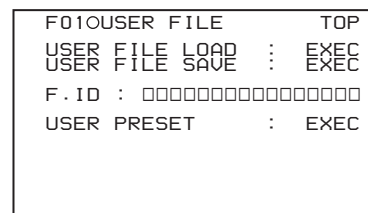

To set a file ID for the data to be saved

Set the file ID before going to step 2.

For details on setting the file ID, see “To set the file ID” on page 148.

- 2 Select USER FILE SAVE, and press the MENU knob.

The USER SAVE page appears.

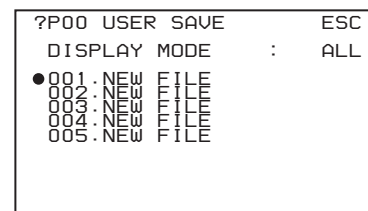

Up to 20 pages, from P00 to P19, can be used to save user files to the “Memory Stick”. Each page can hold up to five files.

- 3 Turn the MENU knob until the page which contains the desired file number appears, and press the MENU knob.

```

P00 USER SAVE          ESC
→DISPLAY MODE        :● ALL
001:NEW FILE
002:NEW FILE
003:NEW FILE
004:NEW FILE
005:NEW FILE

```

4 Select the desired file number, and press the MENU knob.

The message “SAVE OK? YES → NO” appears.

```

P00 USER SAVE          ESC
SAVE OK? YES→NO      :● ALL
DISPLAY MODE
→001:NEW FILE
002:NEW FILE
003:NEW FILE
004:NEW FILE
005:NEW FILE

```

If a file number is followed by “NEW FILE”, this means that the file is empty. If data is stored in the file, the file number is followed by the file name.

5 To carry out the save, select YES and press the MENU knob.

To cancel, press the MENU knob leaving → pointing to NO.

The access indicator lights. When the saving is completed, the message “COMPLETE” appears and the access indicator goes off.

If no “Memory Stick” has been inserted, the message “NO MEMORY STICK” will appear. Insert a “Memory Stick”, and carry out the operation once again.

If you select a file number where data has already been saved

The message “OVERWRITE OK? YES → NO” appears.

- To stop overwriting, press the MENU knob leaving → pointing to NO.
- To overwrite, select YES and press the MENU knob.

You can select the information displayed on each USER SAVE or USER LOAD page.

For details, see “To select the file information items to be displayed” on page 149.

About the USER menu settings to be saved in the “Memory Stick”

Settings for items on all pages of the USER menu are saved in the “Memory Stick” as a user file.

If data cannot be saved

If one of the following error messages appears during or after the save operation, then the data was not saved.

| Error message | Cause | Action |
|-------------------------------|---|---|
| NO MEMORY STICK (flashing) | No “Memory Stick” is inserted. | Insert or reinsert the “Memory Stick”. |
| MEMORY STICK LOCKED | The LOCK switch on the “Memory Stick” is set to the write protect position. | Set the LOCK switch to the write enable position. |
| MEMORY STICK ERROR (flashing) | Circuit or “Memory Stick” fault. | Recheck and consult your Sony dealer. |

To set the file ID

Before data is saved to a “Memory Stick”, it is useful to set a file ID for the “Memory Stick” to identify it.

When data is saved to a “Memory Stick”, the file ID is saved to the “Memory Stick” together with the data.

Note

Set the file ID before saving data in the “Memory Stick”. Otherwise, the file ID is not saved with the other data.

(How to select an item in the menu screen: Turn the MENU knob to move the → mark to the desired item.)

1 Display the USER FILE page of the FILE menu, and press the MENU knob.

For details on menu operations, see “Basic Menu Operations” on page 130.

2 Select F. ID, and press the MENU knob.

A character table appears.

```

F010USER FILE        TOP
USER FILE LOAD      : EXEC
●F.ID :?■           ◀
i#%&'()*+,-./012345678
9:;<=>?@ABCDEFGHIJKLMN
OPQRSTUVWXYZ[^\_`abcde
fghijklmnoparstuvwxy
z~INS DEL RET          ESC END

```

3 Follow steps **3** and **4** described in “Setting the Shot ID” on page 138 to enter characters.

4 When you have finished entering the file ID, turn the MENU knob to move ■ to END, and press the MENU knob.

The entered file ID is now displayed.

```

F010USER FILE      TOP
->USER FILE LOAD  :▷ EXEC
  F.ID : ID-001
  USER PRESET    : EXEC

```

File ID that has been set appears.

After setting the file ID, carry out the procedure from step 2 in “Saving USER Menu Data (User File) to the “Memory Stick”” on page 147.

The set file ID is saved in the “Memory Stick” with the data.

To select the file information items to be displayed

You can select the file information items to be displayed on the USER FILE SAVE page and USER FILE LOAD page (P00 to P19), that are the pages used to save and call up the data to and from “Memory Stick”.

(How to select an item in the menu screen: Turn the MENU knob to move the ➔ mark to the desired item.)

- 1 Display a USER FILE LOAD page or USER FILE SAVE page of the USER FILE menu, and press the MENU knob.

For details on menu operations, see “Basic Menu Operations” on page 130.

- 2 Press the MENU knob, then select the DISPLAY MODE, and press the MENU knob.

- 3 Select the desired type of file information (see the following table), and press the MENU knob.

| Display type | Description |
|--------------|---|
| ALL | File ID (10 characters) and date (year/month/day) |
| F.ID | File ID (16 characters) |
| DATE | Date saved (year/month/day/hours/minutes/seconds) |
| MODEL | Information on the model |

Loading Saved Data from a “Memory Stick”

Note

The data loaded from the “Memory Stick” overwrites the data saved in the camcorder.

(How to select an item in the menu screen: Turn the MENU knob to move the ➔ mark to the desired item.)

- 1 Display the USER FILE page of the FILE menu, and press the MENU knob.

For details on menu operations, see “Basic Menu Operations” on page 130.

- 2 Select USER FILE LOAD, and press the MENU knob.

The P00 USER LOAD page appears.

```

?P00●USER LOAD    TOP
  DISPLAY MODE    : ALL
001 . USER1      JAN/05/06
002 . USER2      JAN/15/06
003 . NO FILE
004 . USER4      FEB/05/06
005 . USER5      FEB/20/06

```

- 3 Turn the MENU knob until the page which contains the desired file appears, then press the MENU knob.

- 4 Select the desired file number, and press the MENU knob.

The message “LOAD OK? YES ➔ NO” appears.

```

P00●USER LOAD    TOP
  LOAD OK?       YES➔NO ALL
  DISPLAY MODE   :
001 . USER1      JAN/05/06
➔002 . USER2      JAN/15/06
003 . NO FILE
004 . USER4      FEB/05/06
005 . USER5      FEB/20/06

```

- 5 To carry out the load, select YES and press the MENU knob.

To cancel, press the MENU knob leaving ➔ pointing to NO.

The access indicator lights.

When the load is completed, the message “COMPLETE” appears and the access indicator goes off.

The USER FILE page appears again.

If data cannot be loaded

If one of the following error messages appears during or after the load operation, then the data was not loaded.

| Error message | Cause | Action |
|-------------------------------|----------------------------------|--|
| NO MEMORY STICK (flashing) | No “Memory Stick” is inserted. | Insert or reinsert the “Memory Stick”. |
| MEMORY STICK ERROR (flashing) | Circuit or “Memory Stick” fault. | Recheck, and consult your Sony dealer. |

| Error message | Cause | Action |
|-----------------------|---|--|
| FILE ERROR (flashing) | The “Memory Stick” contains data that cannot be loaded into this camcorder. | Data saved to a “Memory Stick” using a camcorder whose model is not the same as this camcorder cannot be loaded into this camcorder. |

Saving and Loading Scene Files

You can save various settings for shooting a particular scene as a scene file. Loading the scene file, you can quickly recreate setup conditions suitable for the scene. You can save up to five scene files in the camcorder memory and up to 100 scene files in a “Memory Stick”. You can also load data from the “Memory Stick” into the camcorder memory.

Data that can be saved in a scene file

You can save the following data in a scene file:

- Values adjusted using the PAINT menu
- Shutter speed settings made in the standard mode and ECS mode/SLS mode

For details of the PAINT menu, refer to “PAINT menu” on page 113.

Saving a Scene File

To save a scene file to the “Memory Stick”, insert the “Memory Stick” into the “Memory Stick” slot before starting the operation.

(How to select an item in the menu screen: Turn the MENU knob to move the ➔ mark to the desired item.)

- 1 Display the SCENE FILE page of the FILE menu, and press the MENU knob.

For details on menu operation, see “Basic Menu Operations” on page 130.

| | | |
|--------------------------|--------------|------|
| F04 | SCENE FILE | TOP |
| <input type="checkbox"/> | 1 : STANDARD | |
| <input type="checkbox"/> | 2 : STANDARD | |
| <input type="checkbox"/> | 3 : STANDARD | |
| <input type="checkbox"/> | 4 : STANDARD | |
| <input type="checkbox"/> | 5 : STANDARD | |
| <input type="checkbox"/> | STANDARD | |
| SCENE RECALL | : | EXEC |
| SCENE STORE | : | EXEC |
| F. ID: | STANDARD | |

To set a file ID for the data to be saved

Set the file ID before going to step 2.

For details on setting the file ID, see “To set the file ID” on page 148.

- 2 Select SCENE STORE, and press the MENU knob.

The SCENE STORE page appears.

```
?P00 SCENE STORE      ESC
  DISPLAY MODE       :  ALL
MEM-01:STANDARD
MEM-02:STANDARD
MEM-03:STANDARD
MEM-04:STANDARD
MEM-05:STANDARD
```

- Press the MENU knob, then select the desired file number, and press the MENU knob again.

The file to be saved is selected.

When no “Memory Stick” is inserted

Select the desired memory number, and press the MENU knob.

When the save is completed, the SCENE FILE page appears again.

When you select a file number where data has already been saved

The message “OVERWRITE OK? YES → NO” appears.

- To cancel the overwriting, press the MENU knob leaving → positioning to NO.
- To overwrite, select YES and press the MENU knob.

When a “Memory Stick” is inserted

You can use up to 20 pages, from P01 to P20, to save scene files in the “Memory Stick”. Each page can hold up to five files.

- Turn the MENU knob until the page which contains the desired file appears, then press the MENU knob.

```
P01 SCENE STORE      ESC
→DISPLAY MODE       :●  ALL
001:SCENE1          FEB/05/02
002:STANDARD
003:STANDARD
004:STANDARD
005:STANDARD
***.5FILE SAVE ← MEM1-5
```

- Select the desired file number, and press the MENU knob. The message “STORE OK? YES → NO” appears.

```
P01 SCENE STORE      ESC
STORE OK?          YES→NO
→DISPLAY MODE       :  ALL
001:SCENE1          FEB/05/02
002:STANDARD
003:STANDARD
→004:STANDARD
005:STANDARD
***.5FILE SAVE ← MEM1-5
```

- To carry out the storing, select YES and press the MENU knob. To cancel, press the MENU knob leaving → pointing to NO.

You can select the file information items to be displayed on each page of SCENE STORE and SCENE RECALL.

For details, see “To select the file information items to be displayed” on page 149.

To save scene files stored in the camcorder memory to the “Memory Stick”

The five scene files stored in the camcorder memory can be saved to the “Memory Stick” all in a single operation.

(How to select an item in the menu screen: Turn the MENU knob to move the → mark to the desired item.)

- Display the SCENE FILE page of the FILE menu, and press the MENU knob.

For details on menu operations, see “Basic Menu Operations” on page 130.

- Select SCENE STORE, and press the MENU knob.

- Select the desired SCENE STORE page, and press the MENU knob.

```
P01 SCENE STORE      ESC
→DISPLAY MODE       :●  ALL
001:SCENE1          FEB/05/02
002:SCENE2          FEB/06/02
003:NO FILE
004:SCENE4          FEB/08/02
005:SCENES
***.5FILE SAVE ← MEM1-5
```

- Select 5FILE SAVE ← MEM1-5, and press the MENU knob.

The message “STORE OK? YES → NO” appears.

```
P01 SCENE STORE      ESC
STORE OK?          YES→NO
DISPLAY MODE       :  ALL
001:SCENE1
002:SCENE2
003:NO FILE
004:SCENE4
005:SCENES
→***.5FILE SAVE ← MEM1-5
```

- To carry out the save, select YES and press the MENU knob.

To cancel, press the MENU knob leaving → pointing to NO.

When the save is completed, the message “COMPLETE” appears.

Note

If files have been saved in the page selected in step 3, those files are replaced with files loaded from the camcorder

memory. For example, files from 001 to 005 are replaced by the above procedure.

To set the file ID

Before the data is saved as a scene file, it is useful to set a file ID to identify it. The set file ID is saved together with the data.

(How to select an item in the menu screen: Turn the MENU knob to move the \blacktriangleright mark to the desired item.)

- 1 Display the SCENE FILE page of the FILE menu, and press the MENU knob.

For details on menu operations, see “Basic Menu Operations” on page 130.

- 2 Select F. ID, and press the MENU knob.

A character table appears.

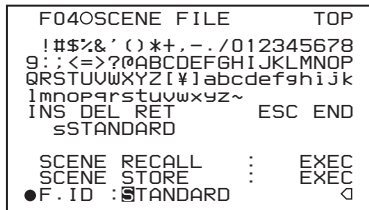

- 3 Press the MENU knob. Then turn the MENU knob until \blacksquare moves to the character position that you want to select, and press the MENU knob.

Example: When entering the letter “+”

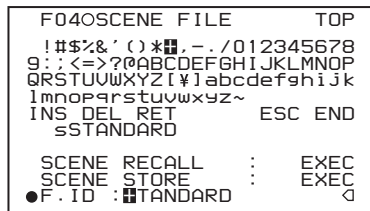

- 4 Repeat step 3 for each of the remaining characters.

Note

Set the file ID before saving the scene file. Otherwise, the file ID is not saved with the other data.

- 5 When you have finished character inputting, turn the MENU knob to move \blacksquare over END, and press the MENU knob.

The file ID is set, and the SCENE FILE page appears again.

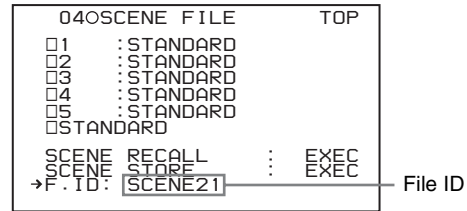

Carry out the procedure from step 2 in “Saving a Scene File” on page 150. The set file ID is saved together with the data.

To select the file information items to be displayed

You can select the items of file information to be displayed on the SCENE STORE pages (P01 to P20) or the SCENE RECALL pages (P01 to P20) used for saving data to or loading data from a “Memory Stick”.

For details to select the item, “To select the file information items to be displayed” on page 149.

Loading Scene Files

(How to select an item in the menu screen: Turn the MENU knob to move the \blacktriangleright mark to the desired item.)

- 1 Display the SCENE FILE page of the FILE menu, and press the MENU knob.

For details on menu operations, see “Basic Menu Operations” on page 130.

- 2 To load the scene file stored in the camcorder, select the desired file number, and press the MENU knob.

\square on the left of the file number changes to \blacksquare . The camcorder is set up according to the loaded scene file.

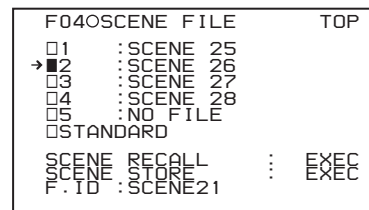

To cancel the selected scene file

Turn the MENU knob to move \blacktriangleright to \blacksquare , and press the MENU knob again. \blacksquare changes to \square . The camcorder returns to the settings before selecting this scene file.

To load a scene file saved in the “Memory Stick”

- ① Select SCENE RECALL, and press the MENU knob. The SCENE RECALL page appears.

```
?P000SCENE RECALL   ESC
  DISPLAY MODE     : F.ID
  →MEM-1:STANDARD
  MEM-2:STANDARD
  MEM-3:STANDARD
  MEM-4:STANDARD
  MEM-5:NO FILE
```

- ② Turn the MENU knob until the page which contains the desired file appears.
- ③ Press the MENU knob, then turn the MENU knob to move → to the desired file number, and press the MENU knob.
The message “RECALL OK? YES → NO” appears.

```
P01 SCENE RECALL   ESC
  RECALL OK? YES→NO ALL
  DISPLAY MODE     : F.ID
  →001 SCENE1
  002 SCENE2
  003 NO FILE
  004 SCENE4
  005 SCENES
  ***.5FILE LOAD → MEM1-5
```

- 3 To carry out the recall, select YES and press the MENU knob.
To cancel, press the MENU knob leaving → pointing to NO.

When the loading is completed, the message “COMPLETE” appears. The camcorder is set up according to the loaded scene file. If no file is present with a particular file number, this is shown as “NO FILE”.

To load scene files from the “Memory Stick” into the camcorder memory

You can load up to five scene files stored in the “Memory Stick” into the camcorder memory all in a single operation.

(How to select an item in the menu screen: Turn the MENU knob to move the → mark to the desired item.)

- 1 Display the SCENE FILE page of the FILE menu, and press the MENU knob.

For details on menu operations, see “Basic Menu Operations” on page 130.

- 2 Select SCENE RECALL, and press the MENU knob.
The SCENE RECALL page appears.

- 3 Turn the MENU knob until the SCENE RECALL page which contains the desired scene files appears, and press the MENU knob.

- 4 Press the MENU knob. Then select 5FILE LOAD → MEM 1-5, and press the MENU knob.

The message “RECALL OK? YES → NO” appears.

```
P01 SCENE RECALL   ESC
  RECALL OK? YES→NO ALL
  DISPLAY MODE     : F.ID
  001 SCENE1
  002 SCENE2
  003 NO FILE
  004 SCENE4
  005 SCENES
  →***.5FILE LOAD → MEM1-5
```

- 5 To carry out the recall, select YES and press the MENU knob.
To cancel, press the MENU knob leaving → pointing to NO.

When loading is complete, the message “COMPLETE” appears and the access indicator goes off.

Notes

- The scene files loaded from the “Memory Stick” overwrite data saved in the camcorder memory.
- To load the scene file saved in the camcorder memory when the “Memory Stick” is inserted, return to the P00 SCENE RECALL page and load the desired scene file in the camcorder memory.
- When there is no file to be loaded (shown as “NO FILE”), an existing file of the same number is unaffected. In the example shown in step 4, MEM(3) is not overwritten.

Resetting the Settings of the Camcorder to the Standard Settings

You can reset the settings of the camcorder to the standard settings.

(How to select an item in the menu screen: Turn the MENU knob to move the → mark to the desired item.)

- 1 Display the SCENE FILE page of the FILE menu, and press the MENU knob.

For details on menu operations, see “Basic Menu Operations” on page 130.

- 2 Select STANDARD, and press the MENU knob.

```
F040SCENE FILE TOP
□1 :SCENE 25
□2 :SCENE 26
□3 :SCENE 27
□4 :SCENE 28
□5 :NO FILE
→■STANDARD
SCENE RECALL :▷ EXEC
SCENE STORE : EXEC
F.ID :SCENE2
```

displayed on the left of STANDARD changes to . When changes to once again, the settings of the camcorder are reset to the settings.

If you press the MENU knob again while is displayed, the operation is cancelled and the camcorder returns to the settings before STANDARD was selected.



Overview

A remote computer can be connected to this unit and used to operate on recorded data which has been saved in data files, such as video and audio data files.

To connect a remote computer, use FAM (file access mode) for the computer connection.

Directory Structure

The following figure shows the directory structure of discs visible to a remote computer.

Note

This structure is not the same as the actual structure recorded on the disc.

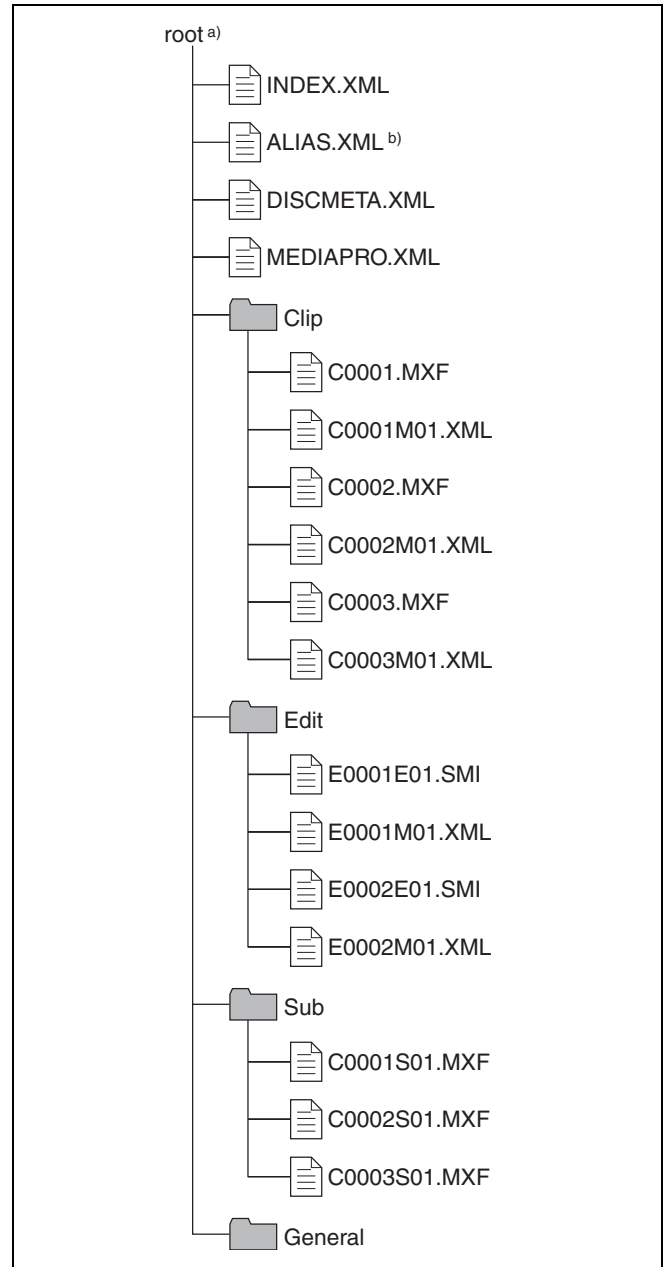

a) Root directory

b) Only when sub item "NAMING FORM" on the FILE NAMING page of the OPERATION menu is set to "FREE".

File Operation Restrictions

This section explains which operations are possible on files stored in each directory.

When required, the following operation tables distinguish reading and writing from partial reading and writing.

Read: Read data sequentially from the start to the end of the file.

Partial read: Read only a part of the data in the file.

Write: Write data sequentially from the start to the end of the file.

Partial write: Write data to a part of the file only.

Root directory

| File name | Content | Operations | | | | |
|-------------------------|---|-------------------|---------------------|--------|--------|--------|
| | | Read/Partial read | Write/Partial write | Rename | Create | Delete |
| INDEX.XML | Contains data for management of the material on the disc. | Yes | No | No | No | No |
| ALIAS.XML ^{a)} | Contains conversion tables for assigning user-defined names to clips and clip lists. | Yes | No | No | No | No |
| DISCMETA.XML | Contains metadata to indicate the disc properties. | Yes | Yes ^{b)} | No | No | No |
| MEDIAPRO.XML | Contains a list of material on the disc, basic properties, related information, and information about access methods. | Yes | No | No | No | No |
| Other files | Files other than the above | – | No | – | No | – |

a) Only when sub item “NAMING FORM” on the FILE NAMING page of the OPERATION menu is set to “FREE”.

b) Only files which can be written by XDCAM.

Notes

- Directories cannot be created in the root directory.
- The directories in the root directory (Clip, Edit, Sub, and General) cannot be deleted or renamed.

Clip directory

| File name | Content | Operations | | | | |
|-------------------------|---|-------------------|-----------------------|------------------|-------------------|-------------------|
| | | Read/Partial read | Write/Partial write | Rename | Create | Delete |
| C*.MXF ^{a)} | Clip file created by recording (MXF file) *: 0001 to 9999 | Yes | Yes ^{b), c)} | Yes | Yes ^{c)} | Yes ^{d)} |
| C*M01.XML ^{a)} | Metadata file generated automatically when C*.MXF file is created. *: 0001 to 9999 | Yes | Yes ^{e)} | No ^{f)} | No ^{g)} | No ^{h)} |
| Other files | Files other than the above | – | No | – | No | – |

a) The “C*” part can be changed to a user-defined name.

b) Overwriting not possible.

c) Only files which are 2 seconds or longer in length, in a format matching the format (system frequency) and recording format (MPEG HD/DVCAM and number of audio channels) of the recorded sections of the disc, and which can be overwritten by XDCAM.

d) Only when the Write Inhibit tab on the disc is set to enable recording. Any clip may be selected and deleted.

e) Only files which can be written by XDCAM

f) When the “C*” part of a C*.MXF file name is changed, a C*M01.XML file with the same name in the “C*” part is also changed automatically.

g) When a C*.MXF file is created, a C*M01.XML file with the same name in the “C*” part is created automatically.

h) When a C*.MXF file is deleted, the C*M01.XML file with the same name in the “C*” part is also deleted automatically.

Notes

- Directories cannot be created in the Clip directory.
- When the following operations are carried out on a disc, then it becomes impossible for version 1.4 and lower XDCAM devices ¹⁾ to record new clips or delete existing

clips on that disc. (The only possible operations are playback and disc formatting.)

- Writing of clips with user-defined names
- Deletion of clips (except the last recorded clip)
- Locking of clips
- If you attempt to write a C*.MXF file which does not meet the conditions specified in remark c) to this table

via a FAM connection, a Windows error message appears to the effect that the file or directory is corrupt and cannot be read.

- 1) PDW-F350/F330, PDW-530/510, PDW-F70/F30, PDW-1500, PDW-R1, PDW-V1, PDW-D1, and PDW-70MD

Edit directory

| File name | Content | Operations | | | | |
|-------------------------|--|-------------------|---------------------|------------------|-------------------|-------------------|
| | | Read/Partial read | Write/Partial write | Rename | Create | Delete |
| E*E01.SMI ^{a)} | Clip list file *: 0001 to 0099 | Yes | Yes ^{b)} | Yes | Yes ^{c)} | Yes ^{d)} |
| E*M01.XML ^{a)} | Metadata file generated automatically when E*E01.SMI file is created. *: 0001 to 0099 | Yes | Yes ^{b)} | No ^{e)} | No ^{f)} | No ^{g)} |
| Other files | Files other than the above | – | No | – | No | – |

- a) The “E*” part can be changed to a user-defined name.
 b) Only files which can be written by XDCAM. Partial writing is not possible.
 c) Only files which can be written by XDCAM
 d) Only when the Write Inhibit tab on the disc is set to enable recording.
 e) When the “E*” part of a *E01.SMI is changed, an E*M01.XML file with the same name in the “E*” part is also changed automatically.
 f) When an E*E01.SMI file is created, an E*M01.XML file with the same name in the “E*” part is also generated automatically.

g) When an E*E01.SMI file is deleted, an E*M01.XML file with the same name in the “E*” part is also deleted automatically.

Note

Directories cannot be created in the Edit directory.

Sub directory

| File name | Content | Operations | | | | |
|-------------------------|--|-------------------|---------------------|------------------|------------------|------------------|
| | | Read/Partial read | Write/Partial write | Rename | Create | Delete |
| C*S01.MXF ^{a)} | Proxy AV data (MXF) file generated automatically when a C*.MXF file is created. *: 0001 to 4999 | Yes | No | No ^{b)} | No ^{c)} | No ^{d)} |
| Other files | Files other than the above | – | No | – | No | – |

- a) The “C*” part can be changed to a user-defined name.
 b) When the “C*” part of a C*.MXF file name is changed, a C*S01.MXF file with the same name in the “C*” part is generated automatically.
 c) When a C*.MXF file is created, a C*S01.XML file with the same name in the “C*” part is generated automatically.
 d) When a C*.MXF file is deleted, the C*S01.XML file with the same name in the “C*” part is also deleted automatically.

Note

Directories cannot be created in the Sub directory.

General directory

| File name | Content | Operations | | | | |
|-----------|---------|-------------------|---------------------|-------------------|--------|-------------------|
| | | Read/Partial read | Write/Partial write | Rename | Create | Delete |
| Any file | – | Yes | Yes | Yes ^{a)} | Yes | Yes ^{b)} |

- a) UTF-8 file names can be up to 63 bytes in length. (Depending on the character type, file names (including extension) may be limited to 21 characters.)
 b) Only when the Write Inhibit tab on the disc is set to enable recording.

The following directory operations are possible in the General directory.

- Directory creation (up to 64 levels, including the General directory)

- Deletion and renaming of directories

Notes

- The maximum number of files that can be created on one disc, including directories, is 5000.
- File names and directory names can use letters, numbers, and symbols ¹⁾ from the Unicode 2.0 (UTF-8) character set.

However, the following control characters and symbols cannot be used.

- Control characters: U+0000 to U+001F, U+007F
- Symbols: ", *, /, :, <, >, ?, \, |

1) The following character codes cannot be used by FAM connections.
 U+010000, U+020000, U+030000, U+040000, U+050000, U+060000,
 0U+70000, U+080000, U+090000, U+0A0000, U+0B0000, U+0C0000,
 U+0D0000, U+0E0000, U+0F0000, U+100000

- To create a new directory in the General directory, first create a directory on the desktop and rename it using only characters that can be used on this unit. Then drag it from the desktop and drop it in the General directory.

File Access Mode File Operations (for Windows)

File access mode operating environment

Operating system requirements for file operations by file access mode (called FAM below) are as follows.

- **Computer operating system:** Microsoft Windows XP Professional SP2 or higher or Microsoft Windows Vista Ultimate/Business (32bit)

Preparations

Install the FAM driver on the remote computer.

To install the FAM driver

Insert the supplied CD-ROM (XDCAM Application) into the CD-ROM drive of your computer, navigate to the FAM Driver directory, and run the installer in the directory for your operating system.

For details, refer to the ReadMe file contained on the CD-ROM disc.

Note

Use version 2.01 or higher of the FAM driver. The FAM driver on the supplied CD-ROM is version 2.01 or higher. If a FAM driver is already installed on your computer, check the version.

To check the FAM driver version

- **For Windows XP:**
 Select Control Panel >Add or Remove Programs >ProDisc, and click on "Click here for support information."
- **For Windows Vista:**

1 Select Control Panel >Programs, open the Programs and Features window, right click in the window's header bar (including the Name, Publisher, and other headers), and select Others...

2 In the Choose Details dialog, check the Version check box and click OK.

The Version column is displayed, allowing you to check the version of ProDisc.

Making FAM Connections



- 1** If there is a disc loaded in this unit, put the unit into the following state.

- Recording, playback, search and other disc operations: Stopped
- THUMBNAIL indicator (*see page 20*): Off
- Disc access by DELETE LAST CLIP, DELETE ALL CLIPS, or QUICK FORMAT on the DISC page of the OPERATION menu, and so on: Stopped
- Interval Rec function: Off
- MENU switch: OFF
- Unsaved current clip list: Save or clear

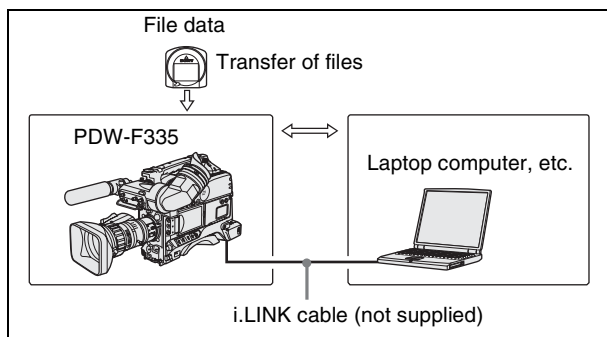
2 Connect the **i** DV OUT S400 connector on this unit to the i.LINK (IEEE1394) connector on the remote computer, using an i.LINK cable.



Windows recognizes this unit as a removable disc, and displays one of the following icons on the remote computer's task bar:

- **Windows XP:** 
- **Windows Vista:** 

The remote computer is now able to perform file operations when a disc is inserted into this unit.

When you make your first FAM connection

The Found New Hardware Wizard dialog appears when you connect this unit to your computer. Select "Install the software automatically (Recommended)", and then click the Next button. Click the Finish button when the software installation finishes.

Operation limitations during FAM connections

- With the exception of the EJECT button, recording buttons and playback control buttons are disabled.
- The VDR of this unit cannot be controlled from devices connected to the REMOTE connector (8-pin) and **i** DV OUT S400 connector.
- There is no signal output from this unit while video is being input to this unit from external equipment.

Operating on Files

Proceed as follows.

1 Start Explorer.

Check that a drive letter has been assigned to this unit. (The drive letter will differ depending on the number of other peripherals connected to the remote computer.)

2 Use Explorer to perform file operations on the disc loaded in this unit.

You can operate in the same way that you operate on local drives and files on network computers.

Notes

- If you power this unit off during an FAM connection, the data transferred thus far is discarded.
- All file operations are not possible for some types of files.

For details, see "File Operation Restrictions" on page 156.

To eject discs from a remote computer



Right click the icon representing this unit in Explorer, and select Eject from the menu which appears.

Exiting File Operations

Proceed as follows.

Note

Do not disconnect the cable before performing steps **1** to **3**.

1 Do one of the following on the  or  icon displayed in the remote computer's taskbar.

- Double click.
- Right click, and select "Safely Remove Hardware" from the menu which appears.

The "Safely Remove Hardware" dialog box appears.

2 Select "Sony XDCAM PDW-F335 IEEE 1394 SBP2 Device" and click "Stop".

The "Stop a Hardware device" dialog appears.

3 Select "Sony XDCAM PDW-F335 IEEE 1394 SBP2 Device" and click "OK".

In Windows XP, "Sony XDCAM PDW-F335 IEEE 1394 SBP2 Device" is deleted from the list of hardware devices.

In Windows Vista, the message "This device can be safely removed from your computer." appears.

This unit can now resume normal operations. (The limitations described in "Operation limitations during FAM connections" on page 159 no longer apply.)

- 4 Disconnect the i.LINK cable as required.

Reconnecting

To reconnect after exiting file operations, do one of the following, depending on whether an i.LINK cable is connected.

i.LINK cable is not connected: Connect this unit and a remote computer with an i.LINK cable.

i.LINK cable is connected: Disconnect the i.LINK cable from either this unit or the remote computer, wait for at least 10 seconds, and then reconnect the disconnected cable.

The unit is powered off and an i.LINK cable is connected: Power the unit on.

File Operations in File Access Mode (for Macintosh)

File access mode operating environment

Operating system requirements for file operations by file access mode are as follows.

- **Computer operating system:** Mac OS X v10.4.11 or higher

Preparations

Do the following on the remote computer and this unit.

- Install the FAM driver on the remote computer (*see the next item*).
- Set i.LINK MODE to "FAM" on the OUTPUT page of the OPERATION menu (*see page 110*).

To install the FAM driver

Insert the supplied CD-ROM (XDCAM Application) into the CD-ROM drive of your computer, and execute the FAM Driver >Mac >FAM Driver 1.1.1.dmg file, then follow the installation instructions.

For details, refer to the ReadMe file contained on the CD-ROM disc.

To check the FAM driver version

Connect this unit to your computer with an i.LINK cable, and then, with a disc loaded, start the system profiler utility of the application. The version appears to the right of "prodisk_fs" when you select "Advanced Functions" under "Software".

Making FAM Connections

- 1 If there is a disc loaded in this unit, put the unit into the following state.
 - Recording, playback, search and other disc operations: Stopped
 - THUMBNAIL button: Off
 - Disc access by clip deletion, disc formatting, or other operation: Stopped
 - Picture Cache function and Interval Rec function: Off
 - MENU button: OFF
 - Unsaved current clip list: Save or clear
- 2 Connect the iDV OUT S400 connector on this unit to the i.LINK (IEEE1394) connector on the remote computer, using an i.LINK cable (*see page 159*).

When a disc is inserted into this unit, the remote computer recognizes this unit as a removable disc. The following icon appears in the Finder on the remote computer, indicating that the computer is now able to perform file operations.



Untitled

Operation limitations during FAM connections

- With the exception of the EJECT button, recording buttons and playback control buttons are disabled.
- Do not use the EJECT button to eject discs. Always eject discs from the computer.
- Do not disconnect the i.LINK cable during a FAM connection. Doing so may result in unstable operation. Always eject any loaded disc before disconnecting the i.LINK cable.

Operating on Files

Proceed as follows.

1 Start the Finder.

Check to be sure that a drive has been assigned to this unit.

2 Operate from the Finder on the files on the disc in this unit.

You can operate in the same way that you operate on local drives and files on network computers.

Notes

- If you power this unit off during a FAM connection, the data transferred thus far is discarded.
- All file operations are not possible for some types of files.

For details, see “File Operation Restrictions” on page 156.

To eject discs from a remote computer

Click the eject button to the right of the icon for this unit in the Finder, or drag the icon for this unit from the Finder to the Trash.

Exiting File Operations

Proceed as follows.

Note

Do not disconnect the cable before performing steps **1** and **2**.

1 Eject the disc by clicking the eject button to the right of the icon for this unit in the Finder, or by dragging the icon for this unit from the Finder to the Trash.

2 Disconnect the i.LINK cable as required.

To make a reconnection

To reconnect after exiting file operations, do one of the following, depending on whether an i.LINK cable is connected.

i.LINK cable is not connected: Connect this unit and a remote computer with an i.LINK cable.

i.LINK cable is connected: The unit is mounted automatically, so you do not need to do anything.

The unit is powered off and an i.LINK cable is connected: Power the unit on.

Recording Continuous Timecode over FAM Connections

For clips created over a FAM connection, you can record so that the timecode is continuous with the timecode of the last frame of the last clip recorded on the disc.

To record continuous timecode

Before you start recording, set the PRESET/REGEN/CLOCK switch on the side control panel inside the protection cover to REGEN. Then write clip files to this unit from a connected computer or other device.

Appendix

Important Notes on Operation

Use and Storage

Do not subject the unit to severe shocks

The internal mechanism may be damaged or the body warped.

Do not cover the unit while operating

Putting a cloth, for example, over the unit can cause excessive internal heat build-up.

After use

Always turn off the POWER switch.

Before storing the camcorder for a long period

Remove the battery pack.

Shipping

- Remove the disc before transporting the unit.
- If sending the unit by truck, ship, air or other transportation service, pack it in the shipping carton of the unit.

Care of the unit

Remove dust and dirt from the surfaces of the lenses or optical filters using a blower.

If the body of the unit is dirty, clean it with a soft, dry cloth.

In extreme cases, use a cloth steeped in a little neutral detergent, then wipe dry. Do not use organic solvents such as alcohol or thinners, as these may cause discoloration or other damage to the finish of the unit.

In the event of operating problems

If you should experience problems with the unit, contact your Sony dealer.

Use and storage locations

Store in a level, ventilated place. Avoid using or storing the unit in the following places.

- In excessive heat or cold (operating temperature range: 0°C to 40°C (32°F to 104°F))
Remember that in summer in warm climates the temperature inside a car with the windows closed can easily exceed 50°C (122°F).
- In damp or dusty locations
- Locations where the unit may be exposed to rain
- Locations subject to violent vibration
- Near strong magnetic fields
- Close to radio or TV transmitters producing strong electromagnetic fields.
- In direct sunlight or close to heaters for extended periods

To prevent electromagnetic interference from portable communications devices

The use of portable telephones and other communications devices near this unit can result in malfunctions and interference with audio and video signals.

It is recommended that the portable communications devices near this unit be powered off.

Note on laser beams

Laser beams may damage the CCDs.

If you shoot a scene that includes a laser beam, be careful not to let the laser beam be directed into the lens of the camera.

Use at a high temperature

If the unit is used at a high temperature, white flecks may appear on the screen.

Fitting the zoom lens

It is important to fit the lens correctly, as otherwise damage may result. Be sure to refer to the section “*Mounting the Lens*” on page 35.

Viewfinder

- Do not leave the unit with the eyepiece pointing directly at the sun.
The eyepiece lens can concentrate the sun’s rays and melt the interior of the viewfinder.
- Do not use the viewfinder close to strong magnetic fields. This can cause picture distortion.

About the LCD panels

LCD panels are manufactured with extremely high-precision technology that yields effective pixel rates of 99.99% or higher. However, very rarely, one or more pixels may be permanently dark or permanently lit in white, red, blue, or green.

This phenomenon is not a malfunction. Such pixels have no effect on the recorded data, and the unit may be used with confidence even if they are present.

Phenomena Specific to CCD Image Sensors

The following phenomena that may appear in images are specific to CCD (Charge Coupled Device) image sensors. They do not indicate malfunctions.

White flecks

Although the CCD image sensors are produced with high-precision technologies, fine white flecks may be generated on the screen in rare cases, caused by cosmic rays, etc. This is related to the principle of CCD image sensors and is not a malfunction.

The white flecks especially tend to be seen in the following cases:

- when operating at a high environmental temperature
- when you have raised the master gain (sensitivity)
- when operating in Slow-Shutter mode

This problem may be alleviated by automatic black balance adjustment (*see page 54*).

Vertical smear

When an extremely bright object, such as a strong spotlight or flashlight, is being shot, vertical tails may be produced on the screen, or the image may be distorted.

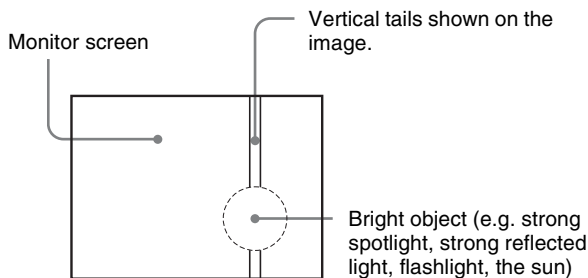

Aliasing

When fine patterns, stripes, or lines are shot, they may appear jagged or flicker.

Condensation

If you move the camcorder from a very cold place to a warm place, or use it in a damp location, condensation may form on the optical pickup. Then, if the camcorder is operated in this state, recording and playback may not be performed properly.

Do the following to prevent this from happening.

- When you move or operate the camcorder in an environment where condensation may form, be sure to insert a disc in advance and close the disc compartment lid.
- Whenever you turn on the POWER switch, check that the HUMID indicator does not appear on the LCD monitor. If it appears, wait until it disappears before inserting a disc.

Maintenance

Testing the Camcorder Before Shooting

Check the functions of the camcorder before setting out for a shooting session, preferably by operating the camcorder together with a color video monitor.

Preparations for testing

- 1 Attach a fully charged battery pack.
- 2 Set the POWER switch to ON and check that the HUMID indicator does not appear and that the remaining battery capacity indicator (■) shows at least five segments.
 - If the HUMID indicator appears, wait until it disappears (*see page 164*).
 - If the remaining battery capacity indicator does not show at least five segments, replace the battery pack with a fully charged one.
- 3 Check that there are no obstructions near the disc compartment, and then press the EJECT button to open the disc compartment lid.
- 4 After confirming that the disc is not write-protected, load the disc and close the disc compartment lid.

Testing the Camera

Set the switches and selectors as follows.

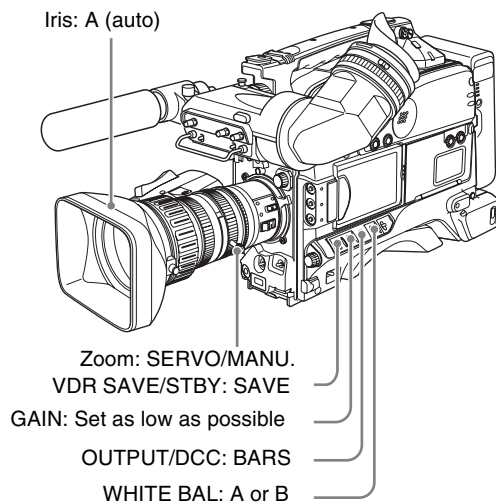

Testing the viewfinder

- 1 Adjust the position of the viewfinder.
- 2 Check that the color bars are displayed on the viewfinder screen, and adjust the BRIGHT, CONTRAST, and PEAKING controls to give the best color bar display.
- 3 Check the following points in the listed order.
 - The menu is displayed on the viewfinder screen.
 - Turn the MENU knob and check that the menu page changes to the next page.
 - Press the MENU knob and check that settings of each item of the selected page are displayed.
 - Turn the MENU knob and check that the ► mark moves within the page.
 - Press the MENU knob and check that the ► mark placed before the item changes to a ● mark and the ● mark placed before the setting of the item changes to a ? mark.
 - Turn the MENU knob and check that the setting of the selected item changes.
- 4 Set the OUTPUT/DCC switch to CAM, and change the FILTER selector position in the sequence of 1 → 2 → 3 → 4.

Check that the FILTER indicator on the viewfinder screen displays the correct numbers.
- 5 Move the SHUTTER switch from ON to SEL repeatedly, and check that the shutter setting changes on the viewfinder screen.
- 6 Pointing the camera at a suitable subject, focus the camera and check the picture on the viewfinder screen.
- 7 Set both of the AUDIO IN switches to FRONT, and check that when sound is input to a microphone connected to the MIC IN connector on the front of the camcorder, the audio level indicators appear on the viewfinder screen.
- 8 Check that setting the ZEBRA button to ON and OFF makes the zebra pattern appear and disappear on the viewfinder screen.

Note

The results of checking in steps **3** to **8** may not be as expected, depending on the settings relating to the viewfinder display function. In this case, set the desired items on the VF DISP 1 and VF DISP 2 pages of the OPERATION menu.

For details, see “Selecting the Display Items” on page 135.

Testing the iris and zoom functions

- 1** Set the zoom to automatic zoom mode and check that the power zoom operates correctly.
- 2** Set the zoom to manual zoom mode and check the zoom functions manually. Turn the manual zoom lever from the telephoto position to the wide-angle position to check that the picture changes depending on the lever position.
- 3** Set the IRIS switch on the lens to A (auto) and point the camera at objects of different brightness. Check that the automatic iris adjustment operates correctly.
- 4** Set the IRIS switch on the lens to M (manual) and check that turning the iris ring manually adjusts the iris correctly.
- 5** Set the IRIS switch on the lens back to A (auto) and check the following points when the GAIN switch is moved from L to M to H.
 - For objects of the same brightness, the iris is adjusted to correspond to the change in setting.
 - The gain indicator on the viewfinder screen changes to correspond to the change in setting.
- 6** When a lens with extender is mounted, set the lens extender lever to the 2x position and check that auto iris functions correctly.

Testing the VDR

Continuously carry out the procedures from “(1) Testing the recording and playback functions” to “(6) Checking the user bit and timecode functions” described below.

(1) Testing the recording and playback functions

- 1** Using the following buttons in the LCD monitor, display the text information.
DISPLAY/EXPAND button: CHAR
COUNTER/CHAPTER button: COUNTER
BRIGHT button: adjustment of backlight brightness
- 2** Set the PRESET/REGEN/CLOCK switch to PRESET, and set the F-RUN/SET/R-RUN to R-RUN.
- 3** Press the REC button and check the following points.
 - The time counter indication in the LCD monitor changes.
 - The REC indicator in the viewfinder is on.

- 4** Press the REC button again.
Check that recording stops and that the REC indicator in the viewfinder goes off.
- 5** Repeat the checks of steps **3** and **4**, this time using the REC button on the lens.
Press the RESET button and check that the indication in the time counter display section of the LCD monitor is reset to “00:00:00:00”.
- 6** Press the F REV button and check that fast reverse playback is performed. Next, press the PLAY/PAUSE button and check that normal playback is performed.
- 7** Press the STOP button and check that playback stops. Next, press the F FWD button and check that fast forward playback is performed.
- 8** Press the STOP button again, then press the PREV button.
Check that the image of the beginning of the current or previous clip is displayed.
- 9** Press the NEXT button, and check that the image of the beginning of the next clip is displayed.

(2) Testing the automatic audio level adjusting functions

- 1** Set both AUDIO IN CH-1 and CH-2 switches to FRONT.
- 2** Set both AUDIO SELECT (CH-1 and CH-2) switches to AUTO.
- 3** Set both AUDIO IN CH-3 and CH-4 switches to F (FRONT).
- 4** Aim the microphone connected to the MIC IN connector at a suitable sound source.
Check that the level indications for channels 1 to 4 correspond to the sound level, respectively.

(3) Testing the manual audio level adjusting functions

- 1** Set both AUDIO IN CH-1 and CH-2 switches to FRONT.
- 2** Turn the MIC LEVEL control.
Check that the channel-1 and -2 audio level meters on the LCD monitor shows no segment when you fully turn the control counterclockwise as seen from the camcorder front.

(4) Testing the earphone and speaker

- 1 Turn the MONITOR knob and check that the speaker volume changes accordingly.
- 2 Connect an earphone to the front or rear EARPHONE jack.

Check that the speaker sound is cut off and that you can hear the sound from the microphone in the earphone.
- 3 Turn the MONITOR knob and check that the earphone volume changes accordingly.

(5) Testing external microphones

- 1 Connect external microphones to the AUDIO IN CH-1 and CH-2 connectors.
- 2 Set the input selection switches as follows.
 - If the connected microphone is of the internal power supply type, set the switch to OFF.
 - If the connected microphone is of the external power supply type, set the switch to +48V.
- 3 Set the AUDIO IN switches to REAR.
- 4 Aim the microphones at a sound source.
- 5 Check that the audio level meters in the LCD monitor, and the audio level indications in the viewfinder change with the volume of the sound.

(6) Checking the user bit and timecode functions

- 1 Set the user bits as required.

For the operation, see "To set the user bits" on page 62.
- 2 Set the timecode.

For the operation, see "To set the timecode" on page 61.
- 3 Set the F-RUN/SET/R-RUN switch to R-RUN.
- 4 Press the REC button, and check that recording starts and that the timecode indication in the time counter display section changes.
- 5 Press the REC button again, and check that recording stops and that the timecode indication stops changing.
- 6 Set the F-RUN/SET/R-RUN switch to F-RUN, and check that the timecode indication starts changing

again and continues to change even when you restart recording and stop recording again.

- 7 Set the COUNTER/CHAPTER button to U-BIT, and check that the user bits data that was set is displayed.

Maintenance

Cleaning the viewfinder

Use a dust blower to clean the CRT screen and mirror inside the viewfinder barrel.
Clean the lens and protecting filter with a commercially available lens cleaner.

Note About the Battery Terminal

The battery terminal of this unit (the connector for battery packs and AC adaptors) is a consumable part. The unit may not operate properly if the pins of the battery terminal are bent or deformed by shock or vibrations, or if they become corroded due to prolonged outdoor use. If you notice bending, deformation, or surface corrosion, contact your dealer or a Sony service representative as soon as possible to have the battery terminal replaced. Periodic inspections are recommended to keep the unit working properly and to prolong its usable lifetime. Contact your dealer or a Sony service representative for more information about inspections.

Operation Warnings

When a problem occurs at power on or during operation, a warning is given by one of the following.

- Warning indicators in the status display on the LCD monitor
- WARNING indicators, and audible warnings from the speaker and earphones

- Indicators on the viewfinder

The volume of the audible warnings can be adjusted with the ALARM knob. Set the ALARM knob to the minimum position to suppress the sound.

| Status display on the LCD monitor/viewfinder screen | WARNING indicator | Warning sound | Indicators in the viewfinder | | Problem | VDR operation | Action to take |
|---|--|---|--|-------------|---|---|---|
| Warning indication | : Continuous : 1 flash/s : 4 flashes/s | Continuous beep : 1 beep/s : 4 beeps/s | REC/TALLY : Continuous : 1 flash/s : 4 flashes/s | BATT | | | |
| E**..** 1) | | | | — | Recording error | Recording stops. | Turn off the power and consult your Sony dealer. |
| MEM Full! | 2) | 2) | 2) | — | Shockproof memory overflow | Recording continuous but may be substandard. | Protect the unit from shocks and vibration. |
| Drive Busy! | 2) | 2) | 2) | — | A clip has been saved to the unit's internal temporary memory but not written to the disc, because of vibrations or some other problem. | Check that recording to the disc is possible, and continue recording. | Reduce vibrations as far as possible, and wait until the ACCESS indicator goes out. |
| ILL.REC! | 2) | 2) | 2) | — | Input sync error | Recording continuous but may be substandard. | Turn off the power and contact your Sony dealer. (This indication may be given momentarily when a GENLOCK signal is connected or disconnected, but this does not indicate a problem.) |
| Disc Error! | 2) | 2) | 2) | — | A disc defect was detected. | Recording continues, avoiding the defect, but may be substandard. | If defects are detected repeatedly, exchange the disc. |

| Status display on the LCD monitor/viewfinder screen | WARNING indicator | Warning sound | Indicators in the viewfinder | | Problem | VDR operation | Action to take |
|---|--|--|--|------|--|---|--|
| | | | REC/TALLY | BATT | | | |
| Warning indication | ☀ : Continuous ☀ : 1 flash/s ☀ : 4 flashes/s | Continuous beep ●●●●●●●●●● 1 beep/s ●●●●●●●●●● 4 beeps/s ●●●●●●●●●● | ☀ : Continuous ☀ : 1 flash/s ☀ : 4 flashes/s | | | | |
| HUMID! | ☀ 2) | ●●●●●●●●●● 2) ●●●●●●●●●● 3) | ☀ 2) | — | Condensation on the optical pickup. | Recording/playback continues but stops when an error occurs on the drive. | Stop recording/playback, turn off the power, then turn it on again, and wait until the HUMID indicator disappears. |
| Before Full 2) | ☀ 2) | ●●●●●●●●●● | ☀ 2) | — | Disc almost full. | Operation continues. | Be prepared to change the disc. |
| Near MAX # | ☀ 2) | ●●●●●●●●●● | ☀ (only when recording the 300th clip) 4) | — | Nine or fewer clips remain until the upper limit of 300 recorded clips is reached. | Operation continues. | Be prepared to change the disc. |
| DISC FULL! 4) | ☀ 4) | ●●●●●●●●●● 4) | ☀ 4) | — | Disc full. | Recording stops. | Change the disc. |
| MAX # Clips | ☀ 4) | ●●●●●●●●●● 4) | ☀ 4) | — | The upper limit of 300 recorded clips has been reached. | Cannot record. | Change the disc. |
| LOW BATT! 2) | ☀ | ●●●●●●●●●● 5) | ☀ 5) | ☀ | Battery almost exhausted. | Operation continues. | Change the battery. |
| BATT EMPTY! | ☀ | ●●●●●●●●●● | ☀ | ☀ | Battery exhausted. | Operation stops. | Change the battery. |
| High TEMP! | ☀ | ●●●●●●●●●● | ☀ | — | Internal temperature high. | Operation continues. | Power the unit off and move it to a cool place. |
| ACC Sensor! | ☀ | ●●●●●●●●●● | ☀ | — | Internal drive sensor error | Operation continues. | Protect the unit from shock and vibrations, turn off the power, and contact your Sony dealer. |
| Skew Sensor | | | | | | | |

- 1) Asterisks (*) are replaced by digits in the display.
- 2) During recording
- 3) During playback, fast forward, fast reverse, or stop
- 4) During recording pause
- 5) During recording or pause

For details about the warning displays and alarm messages on the viewfinder, see the next item.

Operation/alarm messages

An operation or alarm message is displayed in the operation/alarm message display area (see page 29) of the viewfinder screen.

| Operation/alarm message | Meaning |
|-------------------------|---|
| INTERVAL **M**S | Indicates the camera is in the Interval Rec mode. **M**S indicates the shooting interval. |

| Operation/alarm message | Meaning |
|-------------------------|--|
| LOW LIGHT | Appears, depending on the setting, to indicate the subject illumination is inadequate. |
| HIGH TEMPERATURE | Indicates that temperatures have risen inside the unit. Avoid continued use in this state. |

A message for VDR operation is displayed in the setting change and adjustment progress message display area of the viewfinder screen (see page 29).

| Message | Meaning and action to take |
|---|--|
| ILL. Disc! | The disc cannot be used by this unit. Insert another Professional Disc. |
| ILL. Index! No FS! Unknown FS! | Index file or file system error. Exchange or format the disc. |
| No Support! | A recorded clip cannot be handled by this unit. Exchange or format the disc. |
| FORMAT NG! | The disc cannot be used by this unit. Exchange the disc. |
| Disc Damage | The disc cannot be recorded. To record, exchange the disc. |
| Non AV Full MAX # Files | The disc is full. Exchange or format the disc. |
| DI read err Read err DRV ADJ err | The disc was not recognized. Try ejecting the disc and inserting it again. Or exchange the disc. |
| Run Salvage | Salvage processing needs to be done on the disc. To record on the disc, eject the disc, insert it again, and execute salvage processing. |
| Salvage NG | Salvage processing failed. <i>For details, see "Handling of Discs When Recording Does Not End Normally (Salvage Function)" on page 50.</i> |
| REC INHI.! | The Write Inhibit tab of the disc is in the recording disabled position, or salvage processing needs to be done on the loaded disc. Set the tab to the recording enabled position. Or eject the disc, insert it again, and perform salvage processing. |
| HD 50I/25P HD 60I/30P HD 23P Disc 525/60 625/50 2CH×16 Clip 4CH×16 Clip | The loaded disc has a different recording format. Exchange the disc, or change the recording format. |
| Index File! | There is an unsupported index file on the disc to which you are trying to record. Exchange or format the disc. |

| Message | Meaning and action to take |
|-------------------------|---|
| File System | There is an unsupported file system on the disc to which you are trying to record. Exchange or format the disc. |
| KEY INHI.! | Disc operations are not possible when the DC IN connector is not connected and the CA-755 is being used. |
| ILL. PLAY! | An A/V phase error occurred during playback. Stop the disc. |
| Lid Closed! | The lid of the disc compartment does not open. Check the lid. Press the EJECT button to open the lid. |
| Lid Open! | The lid of the disc compartment is not closed. Close it securely. |
| No Clip! | There are no clips recorded on the disc. Exchange for a recorded disc. |
| No Disc! | There is no disc loaded. Insert a disc and try the operation again. |
| STOP ONCE! REC mode! | The operation is not possible while the disc is being played or recorded. Stop the disc. |
| Disc Top! Disc End! | The operation is not possible because the disc is at the top or end. |
| Formatting! | The disc is being automatically formatted. Wait until the format ends. |
| Recording | The unit is writing to the file system. Wait until writing finishes. |
| No EM Space EM Full! | Essence marks cannot be inserted. <i>For details, see "Recording Shot Marks" on page 65.</i> |
| SB CLP mode | Press the SEL/SET button (four-way arrow key) up to clear the SUB CLIP indicator before carrying out the operation. |
| No SEL List | No clip list is selected. Create a new clip list, or load a clip list from the disc. |
| No List! | There is no clip list. Create a clip list. |
| No SUB Clip | There are no sub clips in the clip list. Register a sub clip, or load another clip list. |
| SUB Clip NG | The In and Out point positions are invalid. Set correct In and Out points. |
| MAX# SB CLP | The total number of sub clips is over the upper limit (300). |
| CL OVER DUR | The total duration of sub clips in the current clip list is over the upper limit (24 hours). |

| Message | Meaning and action to take |
|----------------------------|--|
| FAN Stopped DR-FAN Stop | The main unit or drive fan has stopped. Avoid use under high temperatures, turn off the power, and contact your Sony dealer. |

a) REC INHI.! appears if you attempt to start recording.

Alarm messages during thumbnail search, scene selection, and clip list operations

Alarm messages may appear in the LCD monitor during thumbnail search, scene selection, and clip list operations. In this case, take the action indicated in the following table.

| Message | Meaning and action to take |
|---|--|
| CANNOT EXPAND CLIP ANY FURTHER. | The clip cannot be expanded into more blocks. This appears when the EXPAND button is pressed when the number of block is maximum, or when the duration of an expanded thumbnail is 1 frame. |
| SELECTED ESSENCE MARK DOES NOT EXIST. | The selected essence mark does not exist. This appears in the essence mark selection screen when the specified essence mark does not exist on the disc. |
| SUB CLIP IS INVALID. SET APPROPRIATE IN/OUT POINTS. | The temporal relationship between the specified In and Out points in a TRIM operation (see page 91) is not correct. Reset so that the value of the Out point timecode is larger than the value of the In point timecode. |
| DURATION OF ONE CLIP LIST MUST BE LESS THAN 24 HOURS. | The total duration of the current clip list is greater than 24 hours. This appears when the total duration of the current clip list exceeds the upper limit of 24 hours as the result of a sub clip ADD (see page 87) operation or a TRIM operation (see page 91). |
| NO MORE SUB CLIPS CAN BE ADDED TO THE CLIP LIST. | The upper limit of sub clips in the current clip list has been exceeded. This appears when the total duration of the current clip list exceeds the upper limit of 24 hours as the result of a sub clip ADD (see page 87) operation or a TRIM operation (see page 91). |
| SUB CLIP DOES NOT EXIST. | There are no sub clips in the current clip list. This appears when an attempt is made to execute a MOVE (see page 91), TRIM (see page 91), DELETE (see page 92), or TC PRESET operation (see page 93) with no sub clips in the current clip list. |

| Message | Meaning and action to take |
|------------------------------|--|
| CLIP LIST DOES NOT EXIST. | There are no clip lists on the disc. This appears when an attempt is made to execute a DELETE CLIP LIST operation (see page 95) when there are no clip lists on the disc. |
| MOVE IS INVALID. | The sub clip cannot be moved. This appears when an attempt is made to execute a MOVE operation (see page 91) when there are no sub clip in the current clip list, or when there is only 1. |
| SHOT MARK DOES NOT EXIST. | The specified shot mark has not been recorded. This appears when an attempt is made to execute a DELETE SHOT MARK operation on a clip when the specified shot mark has not been recorded for that clip. |
| REC START CANNOT BE DELETED. | REC START cannot be deleted. This appears when an attempt is made to delete a REC START with a DELETE SHOT MARK operation. DELETE SHOT MARK can delete only SHOT MARK1 and SHOT MARK2. |
| CLIP IS LOCKED. | The clip is locked. This appears when an attempt is made to delete a clip, set the clip thumbnail, or delete a shot mark when the clip is locked. |
| ALL CLIPS ARE LOCKED. | All clips are locked. This appears when an attempt is made to execute a LOCK ALL CLIPS operation when all clips are already locked. |
| ALL CLIPS ARE UNLOCKED. | All clips are unlocked. This appears when an attempt is made to execute an UNLOCK ALL CLIPS operation when all clips are already unlocked. |

Troubleshooting

You can use this chart to establish possible causes of an apparent problem; always double-check before sending

the camcorder for repair. If a problem persists, contact your Sony dealer.

| Symptoms | Cause | Remedy |
|---|--|--|
| The camcorder does not power on when you set the POWER switch to ON. | There is no battery pack attached. | Attach a battery pack (see page 31). |
| | The battery pack is exhausted. | Replace the battery pack with a fully charged one (see page 31). |
| | The AC adaptor is not connected. | Connect the AC adaptor (see page 31). |
| Recording does not start when you press the REC button. | The POWER switch is set to OFF. | Set the POWER switch to ON. |
| | The disc has the Write Inhibit tab in the recording disabled position. | Set the Write Inhibit tab to allow recording (see page 48), or change the disc. |
| | The disc is full. | Replace the disc with one with sufficient free space, or format the disc (see page 49). |
| | The inserted disc requires salvage processing. | Carry out salvage processing (see page 50). |
| Playback does not start when you press the PLAY button. | The recording format setting is different from that of the already recorded clips. | Change the disc, or change the recording format (see page 53). |
| | The unit is stopped at the position after recording finished. | Press the PREV button to move to the first frame of a clip, or hold down the PLAY/PAUSE button and press the PREV button to move to any other position. |
| The power supply cuts while operating. | The battery pack is exhausted. | Replace the battery pack with a fully charged one (see page 31). |
| The battery goes dead very quickly. | The operating temperature is very low. | Use a BP-GL95 (see page 31). |
| | The battery pack is inadequately charged. | Recharge the battery pack (see page 31). |
| It is not possible to eject the disc. | The battery pack is exhausted. | Replace the battery pack with a fully charged one (see page 31). If the battery cannot be charged, or there is no replacement battery, use the procedure in the next item, "To eject the disc when there is no power supply" to eject the disc. |
| | The POWER switch is set to OFF. | Set the POWER switch to ON. |
| | The disc surface is scratched, or there is dirt or dust adhering to the disc. | Replace the disc. |
| The playback picture quality is poor. The playback picture does not appear. The playback sound does not hear. | The recording surface of the disc has deteriorated over time. | |
| | The laser diode has deteriorated. | On the HOURS METER page of the DIAGNOSIS menu, check the cumulative light output parameters of the optical head (see page 125). |
| All controls except the EJECT button are disabled. | There is condensation. | Remove the disc and wait with the power on until the condensation has evaporated. |
| Audio recording is not possible. | The AUDIO LEVEL (CH-1/CH-2) knobs are set to the minimum level. | Adjust the setting of the AUDIO LEVEL knobs (see page 13). |
| Audio recording is not possible. | The AUDIO LEVEL knob on the front is set to the minimum level. | Adjust the setting of the AUDIO LEVEL knob on the front (see page 19). |
| The recorded sound is distorted. | The audio level is too high. | Adjust the setting of the AUDIO LEVEL knobs, and record again (see page 19). |
| The recorded sound has a high noise level. | The audio level is too low. | Adjust the setting of the AUDIO LEVEL knobs, and record again (see page 19). |

| Symptoms | Cause | Remedy |
|---|---|---|
| The equipment connected to the camcorder via an i.LINK connection does not react as expected, for example, the video image does not appear on its screen. | It sometimes takes time for the connected equipment to recognize the operation. | Wait for about 15 seconds. If the connected equipment still does not react, do the following. <ul style="list-style-type: none"> • Check the i.LINK cable, for example, by re-plugging the i.LINK cable. • Turn the power off, and connect the cable again. • Change the i.LINK cable. |
| The camera is not recognized by the computer connected via i.LINK interface. | There is a problem with the software, for example, it does not support the MPEG HD/DVCAM format, etc. | Install software that supports the MPEG HD/DVCAM format. |
| The camera cannot be controlled by the computer connected via i.LINK interface. | | |

To eject the disc when there is no power supply

When the battery is exhausted, for example, pressing the EJECT button does not operate the disc ejection mechanism. In such cases, as an emergency measure you can remove the disc manually using the following procedure.

- 1 Turn off the power supply to the unit.
- 2 Carry out the following operations.

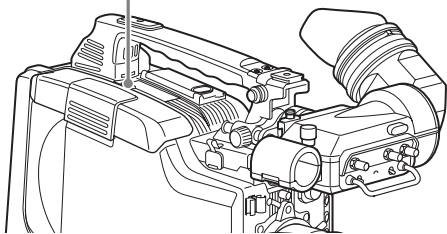
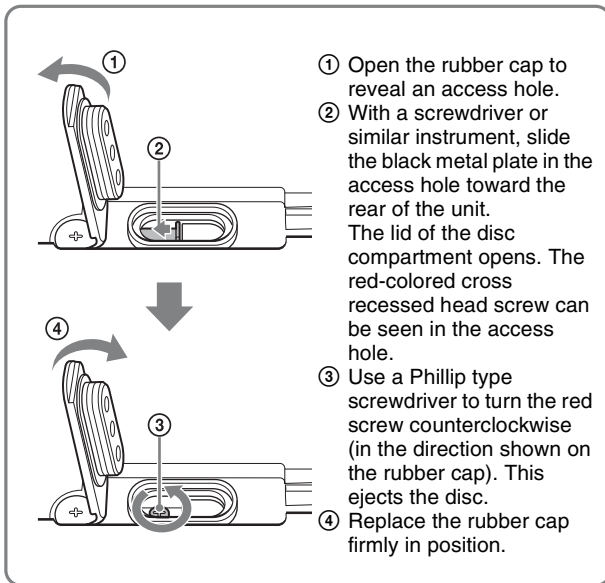

After removing the disc, it is not necessary to return the screw to its original position. When the power supply is restored, the mechanism will again function normally.

Using UMID Data

To perform operations from interviewing to editing effectively and to detect audio-visual materials easily when reusing them, metadata that provides additional information is recorded along with audio-visual data on a disc.

As one of application of metadata, the UMID (Unique Material Identifier) is internationally standardized.

What is a UMID?

The UMID (Unique Material Identifier) is a unique identifier for audio-visual material defined by the SMPTE330M-2003 standard.

The UMID may be used either as the 32-byte Basic UMID or as the Extended UMID, which includes an additional 32 bytes of Source Pack to make a total 64 bytes.

For details, refer to SMPTE 330M.

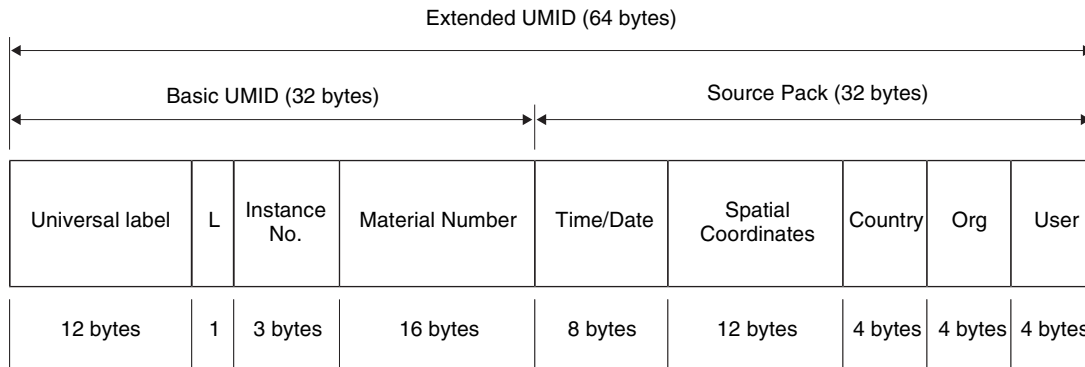

Globally unique ID is automatically recorded every shooting.

The Extended UMID is metadata that provides additional information such as location, time/date, company and so on.

The UMID is applied as follows.

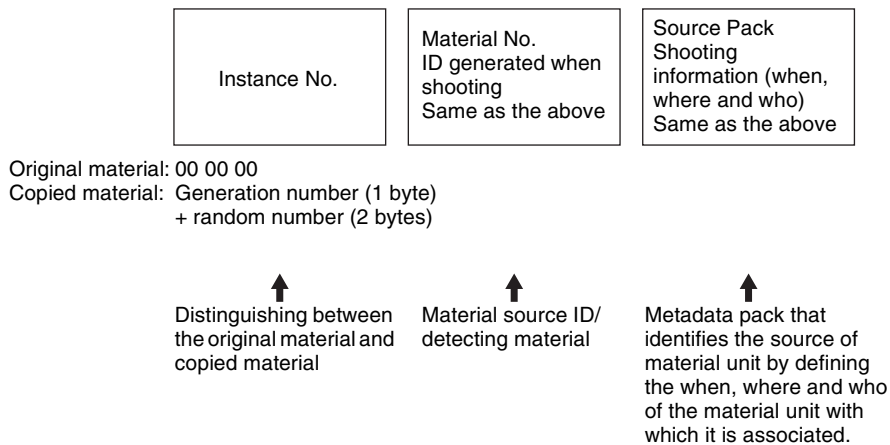

Using the Extended UMID

You have to enter a country code, organization code and user code. Set the country code referring to the ISO 3166 table, and set the organization code and user code independently.

For details, see “Additional information related to the UMID” on page 175.

Functions of UMID data

The UMID data enables the following:

- Add a globally unique ID to every shot of audio-visual material. The unique ID is used to detect the material source and to link it with the original source material.
- Distinguishing between original material and copied material. 00 is added to the Instance Number for original material.
- The UTC is used when recording the UMID. This enables uniform control of source material recorded all over the world based on the universal timecode.
- Calculating the date difference among source materials. The source material is recorded based on the MJD (Modified Julian Date), which enables easy calculation of date difference among source materials.

UMID menu setup

Set the following items required to use UMID data on the UMID SET page of the OPERATION menu.

| Item | Description |
|--------------|------------------------------------|
| COUNTRY CODE | Sets the country code. |
| ORGANIZATION | Sets the organization code. |
| USER CODE | Sets the user code. |
| TIME ZONE | Sets the time difference from UTC. |

For details of the setting operation, see “Basic Menu Operations” on page 130.

Additional information related to the UMID

COUNTRY CODE

When you select this item, the COUNTRY CODE window appears.

Enter an abbreviated alphanumeric string (4-byte alphanumeric strings) according to the values defined in ISO 3166-1.

There are about 240 country codes.

Find your own country code on the following home page. Refer to ISO 3166-1:

http://www.din.de/gremien/nas/nabd/iso3166ma/codlstp1/en_listp1.html

When the country code is less than 4 bytes, the active part of the code will occupy the first part of the 4-bytes and the remainder must be filled with the space character (20h).

Example: In the case of Japan

For Japan, if the country code is JP, it is 2 bytes, if JPN, it is 3 bytes.

Thus, enter the following:

JP _ _

or

JPN _

(where _ represents a space.)

ORGANIZATION (organization code)

When you select this item, the ORGANIZATION window appears.

Enter an abbreviated 4-byte alphanumeric string for the organization code.

Note

There are no problems in recording or playing back audio-video signals, if ORGANIZATION is not set.

Organization codes must be acquired by applying to the SMPTE registration office. When no organization code has been acquired, it is forbidden to enter an arbitrary string. As a rule, the code “00” must be entered. Freelance operators who do not belong to an origination should enter “--”.

USER CODE

When you select this item, the USER CODE window appears.

Enter the 4-byte alphanumeric strings for user identification.

The user code is registered with each ORGANIZATION locally. It is usually not centrally registered.

When the user code is less than 4 bytes, enter the user code from the beginning of the 4 bytes and enter the space character (20h) in the remaining strings.

This user code is determined by the organization. The methods used depend on the organization.

Note

User bits cannot be entered when no organization code has been entered.

TIME ZONE

When you select this item, the TIME ZONE window appears.

The UTC is calculated based on the local time, using the time zone. If the time zone is not set, the UTC is not recorded correctly.

Set the time difference from UTC. When setting the summer time or daylight saving time, change the code to one which will advance the time by 1 hour.

Note

When you change the time zone, adjust the built-in clock to local time and turn the power of the camcorder off and then the power on again.

MPEG-4 License

THIS PRODUCT IS LICENSED UNDER THE MPEG-4 VISUAL PATENT PORTFOLIO LICENSE FOR THE PERSONAL AND NON-COMMERCIAL USE OF A CONSUMER FOR

- (i) ENCODING VIDEO IN COMPLIANCE WITH THE MPEG-4 VISUAL STANDARD (“MPEG-4 VIDEO”) AND/OR
- (ii) DECODING MPEG-4 VIDEO THAT WAS ENCODED BY A CONSUMER ENGAGED IN A PERSONAL AND NON-COMMERCIAL ACTIVITY AND/OR WAS OBTAINED FROM A VIDEO PROVIDER LICENSED BY MPEG LA TO PROVIDE MPEG-4 VIDEO.

NO LICENSE IS GRANTED OR SHALL BE IMPLIED FOR ANY OTHER USE. ADDITIONAL INFORMATION INCLUDING THAT RELATING TO PROMOTIONAL, INTERNAL AND COMMERCIAL USES AND LICENSING MAY BE OBTAINED FROM MPEG LA, LLC. SEE [HTTP://WWW.MPEGLA.COM](http://www.mpegla.com)

MPEG LA is offering licenses for (i) manufacturing/sales of any storage media storing MPEG-4 Visual video information (ii) distribution/broadcasting of MPEG-4 Visual video information in any manner (such as online video distribution service, internet broadcasting, TV broadcasting). Other usage of this product may be required to obtain license from MPEGLA. Please contact MPEG LA for any further information. MPEG LA, L.L.C., 250 STEELE STREET, SUITE 300, DENVER, COLORADO 80206, <http://www.mpegla.com>

MPEG-2 Video Patent Portfolio License

ANY USE OF THIS PRODUCT OTHER THAN CONSUMER PERSONAL USE IN ANY MANNER THAT COMPLIES WITH THE MPEG-2 STANDARD FOR ENCODING VIDEO INFORMATION FOR PACKAGED MEDIA IS EXPRESSLY PROHIBITED WITHOUT A LICENSE UNDER APPLICABLE PATENTS IN THE MPEG-2 PATENT PORTFOLIO, WHICH LICENSE IS AVAILABLE FROM MPEG LA, L.L.C., 250 STEELE STREET, SUITE 300, DENVER, COLORADO 80206.

“PACKAGED MEDIA” means any storage media storing MPEG-2 video information such as DVD movie which are sold/distributed to general consumers. Disc replicators or sellers of the PACKAGED MEDIA need to obtain licenses for their own business from MPEG LA. Please contact MPEG LA for any further information. MPEG LA, L.L.C., 250 STEELE STREET, SUITE 300, DENVER, COLORADO 80206
<http://www.mpegla.com>

About i.LINK

This section explains the specifications and features of i.LINK.

What is i.LINK?

i.LINK is a digital serial interface designed to integrate devices equipped with i.LINK connectors. i.LINK allows your device to:

- Perform two-way transmission and reception of data such as digital audio and digital video signals.
- Control other i.LINK devices.
- Easily connect multiple devices with a single i.LINK cable.

Your i.LINK device is capable of connecting to a wide range of digital AV devices for data transfer and other operations.

Other advantages include the following feature. When connected to multiple i.LINK devices, your i.LINK device can perform data transfer and other operations not only with the directly connected devices but also with any of the devices that are connected to those devices. Therefore, you do not need to be concerned with device connection order. However, depending on the features and specifications of the connected devices, you may need to use certain functions differently, and you may not be able to transfer data or perform certain operations.

i.LINK, a nickname for IEEE 1394 proposed by Sony, is a trademark supported by many companies worldwide. IEEE 1394 is an international standard defined by IEEE, the Institute of Electrical and Electronics Engineers, Inc.

Note

The camcorder can be connected to one device with the i.LINK cable (DV cable). When you connect with a device that has two or more i.LINK connectors, refer to the operating instructions supplied with the connected device.

About data transfer speed of i.LINK

i.LINK defines a maximum data transfer speed of approximately 100, 200 and 400 Mbps¹⁾ that are described as S100, S200 and S400 respectively.

For i.LINK devices, a maximum data transfer speed that the device supports is identified on “*Specifications*” page of the operating instructions supplied with the device or near its i.LINK connector.

When connecting with the device that support different data transfer speed, the actual data transfer speed may be different from those described on the i.LINK connectors.

1) What is Mbps?

Mega bits per second. A measure of the rate at which data is transmitted per second. In case of 100 Mbps, 100 Mega bits of data can be transmitted per second.

i.LINK operation with your camcorder

For details on operation when other equipment with i.LINK (DV) connector is connected, see page 46.

For details on connection with i.LINK cable and necessary software, refer to the operating instructions supplied with the connected device.

Use Sony i.LINK cables

Use Sony i.LINK cables to connect the i.LINK devices.

6 pins ↔ 4 pins (For DV dubbing)

6 pins ↔ 6 pins (For DV dubbing)

i.LINK and  are trademarks.

About a “Memory Stick”

What is “Memory Stick”?

“Memory Stick” is a new compact, portable and versatile IC (Integrated Circuit) recording medium with a data capacity that exceeds a floppy disk. “Memory Stick” is specially designed for exchanging and sharing digital data among “Memory Stick” compatible products. Because it is removable, “Memory Stick” can also be used for external data storage.

“Memory Stick” is available in two sizes: standard size and compact “Memory Stick Duo” size. Once attached to a “Memory Stick Duo” adaptor, “Memory Stick Duo” turns to the same size as standard “Memory Stick” and thus can be used with products compliant with standard “Memory Stick”.

Types of “Memory Stick”

“Memory Stick” is available in the following four types to meet various requirements in functions.

“Memory Stick-R”

Stored data are not overwritten. You can write data to “Memory Stick-R” with “Memory Stick-R” compatible products only. Copyright protected data that requires MagicGate copyright protection technology cannot be written to “Memory Stick-R”.

“Memory Stick”

Stores any type of data except copyright-protected data that requires the MagicGate copyright protection technology.

“MagicGate Memory Stick”

Equipped with the MagicGate copyright protection technology.

“Memory Stick-ROM”

Stores pre-recorded, read-only data. You cannot record on “Memory Stick-ROM” or erase the pre-recorded data.

“Memory Stick PRO”

Equipped with the MagicGate copyright protection technology, designed for use only with equipment compatible with “Memory Stick PRO”.

Available types of “Memory Stick”

With this product, you can use a Sony “Memory Stick” whose capacity does not exceed 128 MB, and a Sony “Memory Stick PRO” whose capacity does not exceed 2 GB.

Note

To use “Memory Stick Duo” or “Memory Stick PRO Duo” with your product, an adaptor needs to be attached.

Note on data read/write speed

Data read/write speed may vary depending on the combination of the “Memory Stick” and “Memory Stick” compliant product you use.

What is MagicGate?

MagicGate is copyright protection technology that uses encryption technology.

Before using a “Memory Stick”

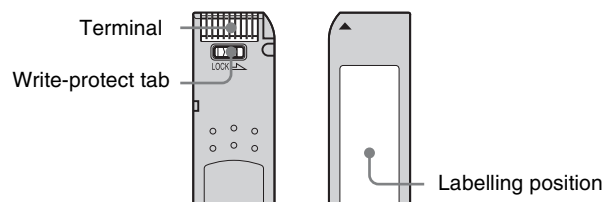

- When you set the “Memory Stick” write-protect tab to “LOCK”, data cannot be recorded, edited, or erased.
- Data may be damaged if:
 - You remove the “Memory Stick” or turn off the unit while it is reading or writing data.
 - You use the “Memory Stick” in a location subject to the effects of static electricity or electric noise.
- We recommend that you make a backup copy of important data that you record on the “Memory Stick”.

Notes

- Do not attach anything other than the supplied label to the “Memory Stick” labelling position.
- Attach the label so that it does not stick out beyond the labelling position.
- Carry and store the “Memory Stick” in its case.
- Do not touch the connector of the “Memory Stick” with anything, including your finger or metallic objects.
- Do not strike, bend, or drop the “Memory Stick”.
- Do not disassemble or modify the “Memory Stick”.
- Do not allow the “Memory Stick” to get wet.
- Do not use or store the “Memory Stick” in a location that is:
 - Extremely hot, such as in a car parked in the sun
 - Under direct sunlight
 - Very humid or subject to corrosive substances

“Memory Stick” access indicator

If the access indicator is turned on or is flashing, data is being read from or written to the “Memory Stick”. At this time, do not shake the computer or product or subject them to shock. Do not turn off the power of the computer and

product or remove the “Memory Stick”. This may damage the data.

Precautions

- To prevent data loss, make backups of data frequently. In no event will Sony be liable for any loss of data.
- Unauthorized recording may be contrary to the provisions of copyright law. When you use a “Memory Stick” that has been pre-recorded, be sure that the material has been recorded in accordance with copyright and other applicable laws.
- The “Memory Stick” application software of the camcorder may be modified or changed by Sony without prior notice.
- Note that there are certain restrictions on recording stage performances and other entertainment events, even if they are recorded for personal use only.

- “Memory Stick”  and “MagicGate Memory Stick” are trademarks of Sony Corporation.
- “Memory Stick Duo” and **MEMORY STICK DUO** are trademarks of Sony Corporation.
- “Memory Stick PRO” and **MEMORY STICK PRO** are trademarks of Sony Corporation.
- “Memory Stick PRO Duo” and **MEMORY STICK PRO DUO** are trademarks of Sony Corporation.
- “Memory Stick-ROM” and **MEMORY STICK-ROM** are trademarks of Sony Corporation.
- “MagicGate Memory Stick” is trademark of Sony Corporation.
- “MagicGate” and **MAGICGATE** are trademarks of Sony Corporation.

Specifications

General

Power voltage 12 V DC +5.0 V/−1.0 V
 POWER consumption
 31 W
 (with 12 V DC supply, when recording
 with the LCD monitor on)
 Operating temperature
 −5°C to +40°C (23°F to 104°F)
 Storage temperature
 −20°C to +60°C (−4°F to +140°F)
 Recording/playback format

| | |
|-------------|---|
| Video | MPEG HD: HQ35/SP25/ LP18 Mbps DVCAM: 25 Mbps |
| Proxy video | MPEG-4 ¹⁾ |
| Audio | MPEG HD: 16 bits, 48 kHz, 4/ 2 channels DVCAM: 16 bits, 48 kHz, 4 channels |
| Proxy audio | A-law 8 bits, 8 kHz, 4 channels |

1) The MPEG-4 CODEC is a product of Ingenient Technologies, Inc.

Recording/playback time
 PFD23/PFD23A discs

| Recording format | Mode | 4-channel audio | 2-channel audio |
|------------------|---------|---------------------|---------------------|
| MPEG HD | HQ mode | 65 minutes or more | 68 minutes or more |
| | SP mode | Approx. 85 minutes | Approx. 90 minutes |
| | LP mode | 112 minutes or more | 122 minutes or more |
| DVCAM | | Approx. 85 minutes | |

PFD50DLA discs

| Recording format | Mode | 4-channel audio | 2-channel audio |
|------------------|---------|---------------------|---------------------|
| MPEG HD | HQ mode | 145 minutes or more | 150 minutes or more |
| | SP mode | Approx. 190 minutes | Approx. 200 minutes |
| | LP mode | 248 minutes or more | 265 minutes or more |
| DVCAM | | Approx. 185 minutes | |

Note

The recording and playback times listed above are approximate. Maximum recording times may vary depending on recording conditions.

Continuous operating time

Approx. 160 min. (with BP-GL95)
 Mass
 Approx. 3.8 kg (8 lb 6 oz) (main body only)
 Approx. 5.45 kg (12 lb) (with DXF-20W Viewfinder, stereo microphone, disc and BP-GL95 Battery Pack)
 Approx. 6.8 kg (14 lb 15 oz) (with DXF-20W Viewfinder, stereo microphone, disc, BP-GL95 Battery Pack and VCL-719BXS Auto Focus Lens)

Dimensions

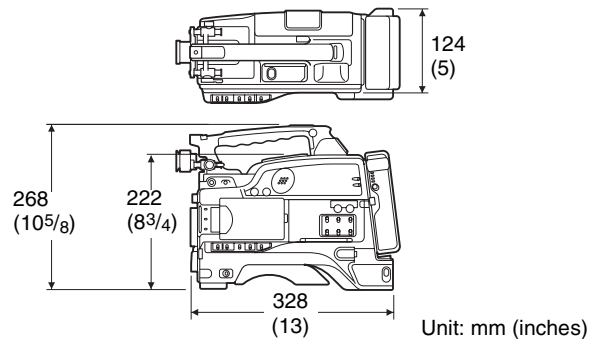

Supplied accessories

VCL-719BXS Auto Focus Lens (1)
 (supplied with PDW-F335K only)
 DXF-20W Viewfinder (1)
 Stereo microphone (1)
 Wind screen (1)
 Shoulder strap (1)
 VCT-U14 Tripod Adaptor (1)
 Lens mount cap (1)
 Flange focal length adjustment test chart (1)
 PFD23A Professional Disc (1)
 XDCAM Application Software CD-ROM (1)
 PDZ-1 Proxy Browsing Software
 PDZ-VX10 XDCAM Viewer
 PDZK-P1 XDCAM Transfer
 Operating Instructions
 English version (1)
 CD-ROM manual (1)
 Warranty Booklet (1)

Video camera section

General

Imager 1/2-inch type, interline transfer CCD
 Effective picture elements
 1440 (H) × 1080 (V)
 Imager configuration
 RGB 3 CCDs
 Spectral system
 F1.4 prism system (with quartz filter)
 Built-in filter
 ND filter

| | |
|----------------------|---|
| | 1: CLEAR |
| | 2: 1/4 ND |
| | 3: 1/16 ND |
| | 4: 1/64 ND |
| Lens mount | Sony 1/2-inch type bayonet-mount |
| Sensitivity | F9 standard (89.9% reflection chart, 2000 lx) |
| Minimum illumination | 0.13 lx (at F1.4, +48 dB gain) |
| Video S/N ratio | 54 dB (Y-typical) |
| Modulation | 800 TV lines |
| Geometric distortion | None identified (excluding distortion due to lens) |
| Smear | -120 dB (Y-typical) |
| LCD | Picture: 8.9 cm (2 1/2 inches) in opposite angle (3.5 type) Pixel resolution: 25,000 pixels (1120 wide × 224 high) Effective picture elements: more than 99.99% |

VCL-719BXS Auto Focus Lens (supplied with the PDW-F335K)

| | |
|-------------------------|--|
| Focal length | 6.7 mm to 127 mm |
| Zoom | Manual or motorized, selectable |
| Zoom ratio | ×19 |
| Maximum aperture | 1:1.6, 1:2.1 (Telephoto) |
| Iris control | Manual or automatic, selectable F1.6 to F16 or C (closed) |
| Focusing | Manual or automatic, selectable |
| Focusing range | 5 cm to ∞ |
| Filter attaching thread | M82 mm, 0.75-mm pitch |
| Mount | Sony 1/2-inch bayonet mount |
| Mass | Approx. 1.34 kg (2 lb 15 oz) (including lens hood) |

External dimensions (w/h/d)

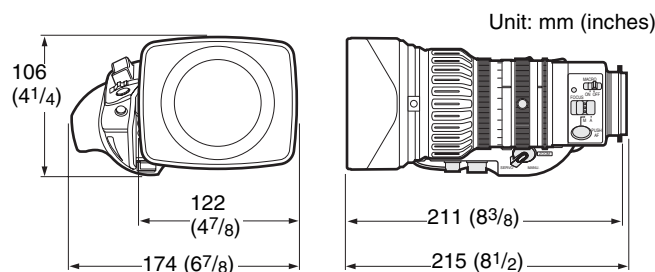

DXF-20W Viewfinder

| | |
|-------------------|---|
| Picture tube | 2-inch, aspect ratio 16:9, monochrome |
| Indicators | REC (×2), TALLY, BATT, SHUTTER, GAIN UP |
| Resolution | 600 lines |
| Power voltage | 12 V DC |
| Power consumption | 3 W |

| | |
|--------------------|--|
| Mass | Approx. 620 g (1 lb 5 oz) |
| Maximum dimensions | 239 × 76 × 215 mm (9 1/2 × 3 × 8 1/2 inches) (w/h/d) |

Stereo microphone

| | |
|--------------------|--|
| Type | Back electret condenser microphone |
| Directivity | Super cardioid |
| Frequency response | 100 Hz to 20 kHz |
| Output impedance | 100 Ω |
| Power voltage | 48 V DC |
| Mass | Approx. 120 g (4 oz) |
| Dimensions | 162 × 21 mm (6 1/2 × 27/32 inches) (length × diameter) (excluding cable) |

Optical Disc Drive Section

Video characteristics

| | |
|--------------------|-----------------------------------|
| Sampling frequency | Y: 74.25 MHz PB/PR: 37.125 MHz |
| Quantization | 8 bits/sample |
| Compression | MPEG-2 MP@HL DVCAM |

Audio characteristics

| | |
|--------------------|---|
| Sampling frequency | 48 kHz |
| Quantization | 16-bit/2-channel, 16-bit/4-channel |
| Headroom | 20/18/16/12 dB (selectable) |
| Frequency response | 20 Hz to 20 kHz +0.5 dB/-1.0 dB (0 dB, 1 kHz) |
| Dynamic range | More than 85 dB |
| Distortion | Max. 0.08 % (1 kHz) |

Input/output connectors

Signal inputs

| | |
|--------------------|--|
| AUDIO IN CH-1/CH-2 | XLR type, 3-pin, female -60 dBu, -50 dB, -40 dBu/+4 dBu (0 dBu = 0.775 Vrms) |
| MIC IN | XLR type, 5-pin, female, -50 dBu |
| GENLOCK IN | BNC type, 1.0 Vp-p, 75 Ω, unbalanced |
| TC IN | BNC type, 0.5 V to 18 Vp-p, 10 kΩ (This can be switched to serve as TC OUT) |

Signal outputs

| | |
|-----------------------|-------------------------------------|
| AUDIO OUT CH-1/CH-2 | Phono jack, -10 dBu, 47 kΩ |
| VIDEO OUT (composite) | BNC type 1.0 Vp-p, 75 Ω, unbalanced |
| VIDEO OUT (component) | |

BNC type (1 set), Y: 1.0 V_{p-p}, 75 Ω,
R–Y/B–Y: 0.7 V_{p-p}, 75 Ω

TC OUT BNC type, 1.0 V_{p-p}, 75 Ω
(This can be switched to serve as TC IN)

EARPHONE (mini jack)
8 Ω, –∞ to –15 dBs variable

Others

DC IN XLR type, 4-pin, male, 11 to 17 V DC

DC OUT 4-pin, 11 to 17 V DC, maximum rated current 0.2 A

LENS 12-pin

REMOTE 8-pin

LIGHT 1) 2-pin

i.LINK 6-pin, complies with IEEE 1394

1) The accessory fitting shoe which you can use to attach a video light to this unit is of the 1/4-inch tapped hole type. If you want to replace this with a slide-type shoe, contact your Sony dealer.

Pin assignment of the connectors

DC IN connector (4-pin, male)

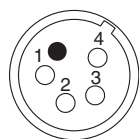

| Pin number | Signal | Standard |
|------------|---------------|-----------------|
| 1 | EXT DC IN (G) | GND |
| 2 | – | – |
| 3 | – | – |
| 4 | EXT DC IN (X) | +11 to +17 V DC |

AUDIO IN CH-1/CH-2 connector (3-pin, female)

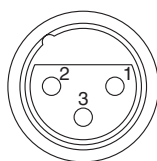

| Pin number | Signal | Standard |
|------------|--------------|---|
| 1 | AUDIO IN (G) | GND |
| 2 | AUDIO IN (X) | –60 dBu, –50 dBu, –40 dBu |
| 3 | AUDIO IN (Y) | When Z1 is equal to or more than 3 kΩ/ +4 dBu, 10 kΩ, balanced |

Related products

There is a range of Sony products available to meet every conceivable video shooting requirement.

For details, consult your Sony sales dealer.

Power supply and related equipment

BP-GL95/GL65/L60S/L80S Battery Pack
BC-L70/M150/L500 Battery Charger
AC-DN2B/DN10 AC Adaptor

Equipment for remote control

RM-B150/B750 Remote Control Unit

Audio equipment

ECM-673/674/678 Microphone
CAC-12 Microphone Holder
CA-WR855 Camera Adaptor
WRR-855 UHF Synthesized Tuner
WRR-861/862 UHF Synthesized Tuner
WRT-822/824 UHF Synthesized Transmitter
WRR Tuner Fitting (service part number: A-8278-057-B)
DMX-P01 Portable Digital Mixer

For Audio equipment described above, confirm whether the connector is male or female and the number of pins on the connector.

The audio input connectors of the camcorder are female and 3-pin. A converting adaptor may be required.

Viewfinder

DXF-51/51CE 5-inch Viewfinder (monochrome)
Accessory Shoe Kit for DXF-51/51CE (service part number: A-8274-968-B)

Cables and miscellaneous

i.LINK cable (DV connecting cable)
CCFD-3L (6-pin ↔ 4-pin, 3.5 m)
CCF-3L (6-pin ↔ 6-pin, 3.5 m)
LC-H300 Hard Carrying Case
LC-DS300SFT Soft Carrying Case
LCR-1 Rain Cover

Design and specifications are subject to change without notice.

Notes

- Always make a test recording, and verify that it was recorded successfully.
SONY WILL NOT BE LIABLE FOR DAMAGES OF ANY KIND INCLUDING, BUT NOT LIMITED TO, COMPENSATION OR REIMBURSEMENT ON ACCOUNT OF FAILURE OF THIS UNIT OR ITS RECORDING MEDIA, EXTERNAL STORAGE SYSTEMS OR ANY OTHER MEDIA OR STORAGE SYSTEMS TO RECORD CONTENT OF ANY TYPE.
- Always verify that the unit is operating properly before use. SONY WILL NOT BE LIABLE FOR DAMAGES OF ANY KIND INCLUDING, BUT NOT LIMITED TO, COMPENSATION OR REIMBURSEMENT ON ACCOUNT OF THE LOSS OF PRESENT OR PROSPECTIVE PROFITS DUE TO FAILURE OF THIS UNIT, EITHER DURING THE WARRANTY PERIOD OR AFTER EXPIRATION OF THE WARRANTY, OR FOR ANY OTHER REASON WHATSOEVER.

Chart of Optional Components and Accessories

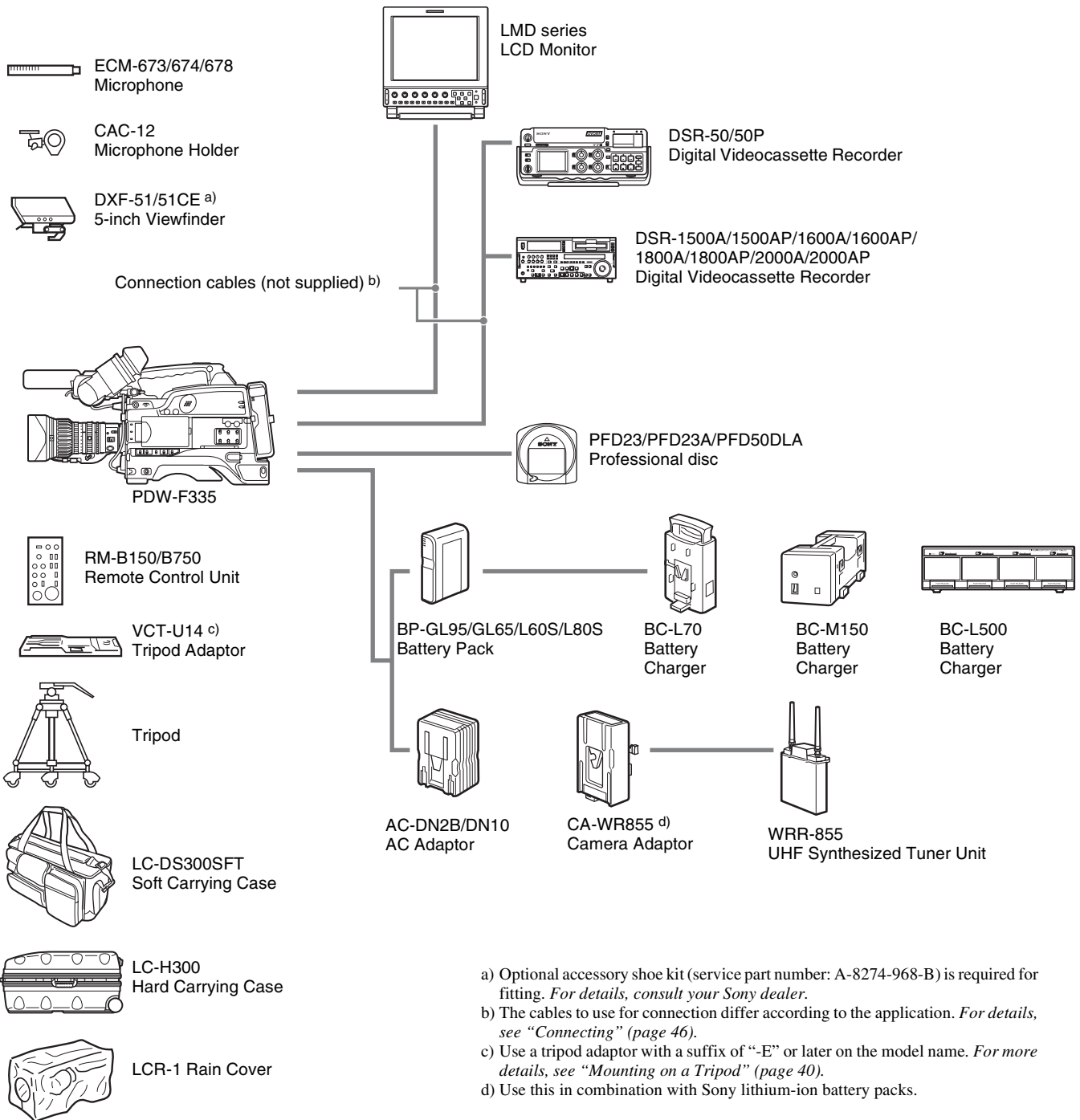

- a) Optional accessory shoe kit (service part number: A-8274-968-B) is required for fitting. *For details, consult your Sony dealer.*
- b) The cables to use for connection differ according to the application. *For details, see "Connecting" (page 46).*
- c) Use a tripod adaptor with a suffix of "-E" or later on the model name. *For more details, see "Mounting on a Tripod" (page 40).*
- d) Use this in combination with Sony lithium-ion battery packs.

Glossary

AES/EBU

A standard established jointly by the AES (Audio Engineering Society) and EBU (European Broadcasting Union) for serial transmission of digital audio. Two channels of audio can be transmitted via a single connector.

Aliasing

Distortion which occurs during sampling to convert analog signals to digital.

ATW

Auto Tracing White balance. The white balance is automatically adjusted for the lighting conditions during shooting.

Bayonet type

A type of lens mount. The lens can be inserted into the lens mount and fixed in place by rotating a ring.

Black balance

To balance the black level of the R, G, and B signals so that black has no color.

Black set

A reference level for black balance adjustment.

CCD

Abbreviation for charge-coupled device. A semiconductor device used in place of a camera pickup tube. A semiconductor used in place of a camera tube. The CCD converts light into electrical charge, and outputs the electrical charge in the form of varying voltages.

Center marker

A cross on the viewfinder screen that indicates the center of an image.

Clip

A recording unit. Clips are created every time recording starts and stops.

Clip list

A list of locations in the material recorded on the disc, arranged in any order. Clip lists can be created with

the scene selection function of this unit, and with the supplied PDZ-1 Proxy Browsing Software.

Color bar signals

Test signals displayed on the screen as multicolored vertical stripes. Used for adjustment of hue, and saturation of a video camera and video monitor.

Color subcarrier

In a composite video signal, a signal superimposed upon the picture (luminance) information for the purpose of conveying the associated color information. Color and saturation information is conveyed by the phase and amplitude of the color subcarrier. Also called subcarrier.

Color temperature

The color quality of light, expressed in Kelvin (K).

Reddish colors have a lower color temperature, and blueish colors a higher color temperature.

CRT

Cathode-Ray Tube. Video camera viewfinders are equipped with a CRT image display, so you can monitor what you are shooting.

DCC

Abbreviation for dynamic contrast control. To provide a larger dynamic range for a video camera (the range of brightnesses of subjects that can be handled by the imaging device), the knee-point is automatically adjusted with variations in the incident light.

Drop-frame mode

SMPTE timecode runs at 30 frames/second, while the NTSC color television system runs at about 29.97 frames/second. Drop-frame mode adjusts the running of timecode to eliminate the discrepancy between timecode value and actual time by dropping two frames from the timecode value at the beginning of each minute except every tenth minute.

EBU

Abbreviation for European Broadcasting Union. A professional

broadcasting establishment in Europe.

E-E mode

Electric-to-Electric mode. When you operate a VDR in E-E mode, input video and/or audio signals pass through electric circuits only and then come out from the output connectors, without passing through electromagnetic conversion circuits such as recording heads.

EFF

Electronic Field Production. The use of electronic equipment such as portable video cameras, VTRs, and sound equipment for television production outside studios.

ENG

Electronic News Gathering. The use of electronic equipment such as portable video cameras, VTRs, and sound equipment for the production of daily news stories and short documentaries.

Essence mark

A type of metadata that may be set for a specified frame.

EXT TC (External timecode)

A timecode input from external equipment together with audio data. It corresponds to the conventional timecode recorded on tape based media. Instead the EXT TC is usually used to record timecodes and audio signals that are played back by equipment that is not synchronized with the reference video signal.

Ff

See "*Flange focal length*".

Flange focal length

The distance from the plane of lens mounting flange to the image focal plane. Abbreviated to Ff.

Flare

Dark or colored flashes caused by signal overload through extreme light reflections of polished objects or very bright lights.

Flicker

Repeated changes in screen brightness caused by an interference

between the camera's scanning and the lighting conditions.

GENLOCK

A state in which devices are locked to a signal output by a sync generator. Genlock allows multiple devices to operate in synchronization.

HDSDI signal

Abbreviation for High Definition Serial Digital Interface.

This is an uncompressed digital component video signal as specified by SMPTE 292M.

Horizontal resolution

The horizontal resolution of the screen, which is expressed as the number of vertical lines distinguishable when shooting a test chart.

Hunting

Repeated brightening and darkening of an image resulting from repeated response to automatic iris control.

i.LINK

Another name for the IEEE1394-1995 standards and their revisions. On devices from other manufacturers, the  (i.LINK) DV OUT S400 connector may be called a "FireWire port", or indicated as IEEE 1394 or DV IN/OUT. XDCAM HD uses the i.LINK interface to transfer DV streams by the AV/C protocol, and to read and write MPEG IMX and DVCAM data files by FAM (File Access Mode).

Interlaced scan mode

A scanning method in which odd rows fields are read alternately with even rows. (Odd-row fields and even-row fields contain images from different times.)

IRE scale

International Radio Engineers scale. A scale of values that defines the brightness level of a video signal. The IRE is now the IEEE (Institute of Electrical and Electronic Engineers).

Metadata

Information about the properties of video and audio content. XDCAM records metadata such as UMIDs and

essence marks, and the supplied PDZ-1 Proxy Browsing Software can be used to record information such as titles and comments.

MXF

Material eXchange Format. A file exchange format developed by the Pro-MPEG Forum. Equipment from different manufacturers can exchange files in this format.

ND filter

ND is an abbreviation of Neutral Density. An optical filter that reduces the incident light uniformly across the whole wavelength range, without affecting the color rendering of the subject.

Non-drop-frame mode

A mode of advancing timecode which ignores the difference in frame values between real time and the timecode. Using this mode produces a difference of approximately 86 seconds per day between real time and timecode, which causes problems when editing programs in units of seconds using the number of frames as a reference.

Non-audio

General term for audio signals other than linear PCM, such as Dolby E and Dolby Digital (AC-3).¹⁾ XDCAM can record non-audio as an input signal.

1) Dolby is a trademark of Dolby Laboratories.

NTSC

Abbreviation for National Television System Committee. NTSC is a color TV broadcasting system adopted mainly in North American countries, and in parts of Asia and Central and South America.

PAL

Abbreviation for Phase Alternating Line. PAL is a color TV broadcasting system developed by Telefunken GmbH of Germany. This system is adopted mainly in European countries, in Australia, and in parts of Asia and South America.

Progressive scan mode

A scanning method in which odd rows and even rows are read at the

same time. Also called full-screen scanning.

Proxy AV data

Low-resolution data with a video bandwidth of 1.5 Mbps and an audio bandwidth of 64 kbps per channel. This unit records proxy AV data automatically whenever high-resolution MPEG HD or DVCAM data is recorded.

Reference video signal

A video signal that contains a sync signal or sync and burst signals, used as a reference for synchronization of video equipment.

Return video

Video signals that are sent back from a VTR to a camera or from a control console to a camera so that a camera operator can verify the recorded/selected video signals.

Sampling frequency

A method used to sample an analog signal so that it can be represented digitally. The higher the sampling frequency is, the more accurately the high-frequency analog signal can be represented.

SDSDI signal

Standard Definition Serial Digital Interface. An interface standardized as SMPTE 259M which enables the transmission of an uncompressed digital component stream.

Shot data

Data recorded, while shooting, in the color bars, the user bits data of VITC, and so forth. Includes the model name, serial number, date, time, shot number, and ID1 to ID4.

Shutter speed

The time that the shutter is open. Slow shutter speeds give bright images, but motion resolution is lower.

SMPTE

Society of Motion Picture and Television Engineers, a professional association established in the U.S.A. mainly for the purpose of setting forth motion picture and television engineering standards.

S/N

Signal-to-Noise ratio. The relation of the strength of the desired signal to the accompanying electronic interference, the noise. If S/N is high, sounds are reproduced with less noise and pictures are reproduced clearly without snow.

Sub clip

One of the sections which make up a clip list. A sub clip may be part of a clip or an entire clip.

Superimpose

A procedure you use to put one picture (or character) over another so that both can be seen at the same time.

Thumbnail image

A reduced still picture of video for display on a GUI screen. XDCAM creates thumbnail images from proxy video, and displays them as index pictures on GUI screens.

Timecode

A digitally encoded signal which is recorded with video data to identify each frame of the video by hour, minute, second and frame number. SMPTE timecode is applied to NTSC system, and EBU timecode to PAL and SECAM systems.

Timecode synchronization

To synchronize the built-in timecode generator of video equipment to an external timecode.

Time data

Time information that is generated by a timecode generator or read by a timecode reader.

Turbo gain

Video amplifier gain increased from 30 dB by 6 to 18 dB by combining adjacent pixels of the CCD.

UMID

Unique Material Identifier. A standard (SMPTE 330M) for video and audio metadata. The Basic section of a UMID contains a globally unique number and a material number for the identification of recorded material. An optional section called the Source Pack

contains information such as the time and location of recording. A UMID with the Basic section only is called a Basic UMID. A UMID with the Source Pack is called an Extended UMID.

User's bits

Abbreviation for Total Level Control System. A function to operate the automatic gain control (AGC) and electronic shutter (AE) to adapt to varying lighting conditions while shooting.

VBS

Abbreviation for video-burst-sync. A composite signal consisting of a video signal, a burst signal, and a sync signal.

Vertical smear

A bright vertical line which appears on the screen when shooting a very bright object with a CCD camera. Also called smear.

Video gain

Amount of amplification for video signals, expressed in decibels (dB).

VITC

Abbreviation for vertical interval timecode. A timecode recorded on disc with video signals and inserted in the vertical blanking interval of video signals. The VTR can read this timecode even in still mode.

White balance

The balance of the levels of the red, green, and blue channels of a color video camera level. When this balance is correctly adjusted, white tones appear as a true white.

White shading

When shooting a white subject with a color video camera, if the lens characteristics are such that while the center of the image appears white, the upper and lower portions suffer a color imbalance, appearing magenta or green. This phenomenon is called white shading.

Zebra pattern

Striped patterns that appear in the viewfinder to indicate areas of the

picture where the video level is about 70 IRE units or 490 mV.

Zoom

To gradually change the field of view of a camera lens from wide to narrow angle (zoom in) or narrow to wide angle (zoom out).

Index

Numerics

- 23.98P mode 144
- 5600 indicator 29
- 5600K button 14
- 5-inch electronic viewfinder, attaching 38

A

- About data transfer speed of i.LINK 177
- AC adaptor 31
- ACCESS indicator 18
- Accessory fitting shoe 22
- ADVANCED menu 126
- ALARM knob 15
- Alarm messages 169
- Area of use
 - setting 32
- Aspect Ratio, selecting 144
- ASSIGN 1/2 switches 13
- ASSIGN 3/4 switches 21
- ASSIGNABLE page 108
- Assigning functions to ASSIGN switches 143
- ATW 15, 56
- Audio channel
 - display 17
 - selecting 20
- AUDIO IN CH-1/CH-2 connectors 24
- AUDIO IN input selection switches 24
- AUDIO IN switches 20
- Audio input
 - external microphone 41
 - supplied microphone 41
- Audio input signal selection 20
- Audio level
 - adjusting 60
 - indicator 17, 29
- Audio level adjustment method selection 20
- AUDIO LEVEL knob (front) 13
- AUDIO LEVEL knobs 20
- AUDIO LEVEL knobs (side) 20
- AUDIO OUT CH-1/CH-2 connectors 24
- AUDIO SELECT switches 20
- AUDIO-1 page 117
- AUDIO-2 page 118
- Auto focus button 25
- Auto focus indicator 25
- Auto focus lens 25

- Auto focus ranging sensor 12
- AUTO W/B BAL switch 12
- Automatic iris, setting 59

B

- BATT indicator 27
- Battery attachment shoe 23
- Battery capacity indicator 17
- Battery pack
 - attaching 31
 - detaching 31
 - operation time 31
- Black balance
 - automatic adjustment 12, 54
- BRIGHT button 16
- BRIGHT control 28
- Built-in speaker 18

C

- CAM CONFIG page 120
- Camera person TALLY indicator 27
- Camera scan mode indicator 17
- Change confirmation/adjustment
 - progress messages 136
- Chapter function 79
 - adding sub clips 90
- Clip 86
 - assigning titles automatically 69
 - Assigning User-Defined Clip names 71
 - deleting 64, 82
 - Locking 81
 - recording 52
- Clip Continuous Rec 73
- Clip list 86
 - creating 87
 - deleting from the disc 95
 - managing 94
 - name display 29
 - playback 80
 - Sorting 95
- CLIP TITLE page 109
- CLK 18
- CNT 18
- Color bar signal, outputting 15
- Color temperature, setting 140
- Component video signal output connector 22
- Composite video signal output connector 24
- Connecting
 - controlling from a non-linear editing system 47
 - controlling from the VTR using the editing function 47
 - copying digitally 46

- external video monitor 46
- i.LINK connection settings 46
- Connector section 22
- CONTRAST control 27
- COUNTER/CHAPTER button 16
- Current clip list 86
 - reading from the disc 95

D

- Date/time
 - setting 34
- DC IN connector 23
- DC OUT 12 V connector 24
- DCC (Dynamic Contrast Control) 15
- DETAIL page 114
- DF/NDF 61
- DIAGNOSIS menu 125
- Directory Structure 155
- Disc
 - ejecting 19
 - handling 48
 - loading and unloading 49
 - remaining capacity indicator 17, 29
 - write-protecting 48
- DISC page 109
- Display items, selecting 135
- DISPLAY switch 28
- DISPLAY/EXPAND button 15
- DV OUT connector 24

E

- EARPHONE jack 18
- ECS 57
- E-E 18
- EJECT button 18, 19
- Electronic shutter 57
- ESSENCE MARK page 119
- Essence Marks
 - recording 65
- Expand function 79
 - adding sub clips 89
- External synchronization indicator 17
- Eyepiece focusing knob 27
- Eyepiece focusing ring 27
- EZ focus 52, 143
- EZ mode 51, 143
- EZ MODE/TLCS page 109

F

- F FWD button 19
- F REV button 19
- FAM connections 158
- Features 9
- File access mode (FAM) 158
- FILE menu 123

File operation 155
 restrictions 156
 Filter indicator 29
 FILTER selector 12
 Fitting for optional microphone holder
 22
 Flange focal length adjustment button
 25
 Flange focal length, adjusting 35
 using a non-auto focus lens 36
 using the VCL-719BXS auto
 focus lens 35
 Flicker 54
 Focus control connector 26
 Focus indicator 28
 Focus ring 25
 FOCUS switch 25
 FORMAT page 108
 Four-way arrow key 20
 Frame frequency
 setting 32
 FRONT MIC LOW CUT switch 21
 F-RUN/SET/R-RUN switch 21

G

Gain
 setting values for the GAIN
 selector positions 140
 value 29
 GAIN SW page 109
 GAIN switch 14
 GAIN UP indicator 27
 Gamma Tables 142
 GENLOCK IN connector 22
 Glossary 185

H

“Memory Stick”
 handling 146
 Hold indicator 17

I

i.LINK
 data transfer speed 177
 overview 177
 settings required for connection
 46
 i.LINK connector 24
 IEEE1394 connector 24
 IG control 26
 Internal timecode generator
 selecting operating mode 21
 Interval Rec 66
 settings before shooting 66
 shooting 67
 IRIS button 26

Iris gain control 26
 Iris ring 25
 Iris setting/auto iris override indicator
 29
 IRIS switch 26
 Iris, adjusting 59

K

KNEE page 114

L

Large viewfinder attachment shoe 21
 LCD monitor 15
 operating buttons 15
 status display 16, 135
 LCD page 111
 Lens 25
 mounting 35
 LENS connector 12
 Lens file, selecting 143
 Lens locking lever 13
 Lens mount 12
 Lens mount cap 12
 Lens mount securing rubber 12
 LIGHT connector 22
 LIGHT switch 14
 Line input audio equipment,
 connecting 44
 Lithium battery
 attaching and replacing 30
 service life 30
 warning indicator 17
 Lithium battery compartment 20
 Lock ring 27
 LOW KEY SAT page 115
 Low-Noise mode 142

M

MACRO switch 25
 Maintenance
 cleaning the viewfinder 167
 MAINTENANCE menu 117
 Marker display, setting 136
 MARKER page 111
 MATRIX 2 page 115
 MATRIX page 115
 “Memory Stick”
 handling 146
 inserting 146
 overview 178
 protecting saved data 147
 removing 146
 types 178
 “Memory Stick” slot 23, 146
 Menu
 adjustments and settings 140

ADVANCED menu 126
 basic operations 130
 DIAGNOSIS menu 125
 displaying 130
 ending 130
 FILE menu 123
 MAINTENANCE menu 117
 OPERATION menu 108
 organization 98
 PAINT menu 113
 USER menu 131

MENU knob 13
 Menu list 107
 MENU switch 15
 MIC IN connector 22
 Microphone, attaching 41
 MONITOR knob 14
 MONITOR OUT CHARACTER
 switch 21
 MONITOR switches 20
 MPEG-4 License 176

N

ND filter, selecting 12
 NEXT button 19
 Non drop-frame mode indicator 17

O

OFFSET WHITE page 110
 OPERATION menu 108
 Operation warnings 168
 Operation/alarm message display area
 29
 Operation/alarm messages 169
 Optional components and accessories
 184
 OUTPUT page 110
 Output signals, selecting 140
 OUTPUT/DCC switch 15
 Overview 8

P

PAINT menu 113
 PAINT page 113
 PDZ-1 97
 PEAKING control 27
 Picture Cache Function 68
 PLAY/PAUSE button 19
 Playback 74
 clip list 80
 indicator 17
 Power source voltage / battery
 remaining capacity 28
 Power supply
 preparing 31
 POWER switch 14

Power zoom lever 26
Pre-lighting function 66
PRESET/REGEN/CLOCK switch 21
PREV button 19
Product configurations 8
PUSH AF button 25

R

REC button 12, 26
REC/TALLY indicators 27
Recording
 advanced operation 66
 basic operation 53
 checking on a color video monitor 75
 Clip Continuous Rec 73
 review 75
 shot data superimposed on the color bars 137
 Starting a Shoot with a Few Seconds 68
Recording format
 indicator 17, 28
 selecting 53
Recording level adjustment 20
Remaining disc capacity indicator 17
REMOTE connector 24
Remote control unit
 camcorder switch functions when connected 44
 connecting 44
 paint adjustment when connected 44
 structure of the paint adjustment data 45
RESET button 16
RESET page 112
RET button 26

S

S400 connector 24
Scan mode 144
 indicator 17
Scene file
 loading 152
 saving 150
 setting the file ID 152
SCENE FILE page 116
Scene selection
 creating clip list 87
 editing sub clips 91
 flow of editing 85
 managing clip lists 94
 overview 84
Searching
 chapter function 79

 expand function 79
 thumbnail 76
SEL/SET button 20
Setting change and adjustment
 progress message display area 29
SHIFT button 20
Shooting 51
SHOT DISP page 112
SHOT ID page 112
Shot ID, setting 138
SHOT MARK 65
Shoulder pad 22
 adjusting the position 39
Shoulder strap
 fitting 39
 removing 39
Shoulder strap fitting 22
SHUTTER indicator 27
Shutter mode 57
Shutter speed 57
 indicator 29
SHUTTER switch 13
Side control panel 19
 protection cover 18
SKIN DETAIL page 115
Skin detail, correcting 64
SLS 57, 58
SPECIAL EFFECTS page 108
Specifications
 general 180
 optical disc drive section 181
 pin assignment of the connectors 182
 related products 182
 stereo microphone 181
 supplied accessories 180
 video camera section 180
Starting a Shoot with a Few Seconds 68

Status display 139
STOP button 19
Stopper 27
SUB CLIP indicator 20
Sub clips 86
 editing 91
Superimposed text
 adding 21
SW STATUS page 113

T

TALLY light 23, 27
Tally light 28
TALLY switch 23
TALLY switch (viewfinder) 28
TC connector 24
TCG 18
TCR 18

Testing
 camera 165
 preparing 165
 VDR 166
THUMBNAIL button 20
Thumbnail image
 Changing index frame 77
 Setting at recording time 65
 Switching the information 77, 93
THUMBNAIL indicator 20
Thumbnail search 76
TIME / DATE page 112
Time counter display 18
Timecode
 indicator 28
 making the time code consecutive 61
 saving the actual time 61
 setting 61
TIMECODE page 119
TLCS 109, 143
TOP menu 106
Tripod
 mounting 40
 removing 40
Troubleshooting 172

U

UBG 18
UBR 18
UHF synthesizer tuner, attaching
 WRR-855 43
 WRR-861/862 43
UMID Data 174
UMID SET page 112
User bits, setting 62
User file
 loading 149
 saving 147
 setting the file ID 148
USER menu
 editing 132
 moving to another page 132
 resetting 135
 setting 131
USER MENU CUSTOMIZE menu
 adding a new page 132
 adding/deleting/replacing pages 134

V

VCL-719BXS 25
VDR operation indicators 28
VDR SAVE/STBY switch 14
VF connector 12
VF DISP 1 page 111

VF DISP 2 page 111
VF SETTING page 111
Video camera section 180
Video light, attaching 40
VIDEO OUT CHARACTER switch
21
VIDEO OUT connector 24
VIDEO OUT page 110
VIDEO OUT Y/PB/PR connector 22
Video signal from the camera,
outputting 15
Viewfinder 27
 adjusting contrast and brightness
 38
 adjusting the eyepiece focus 38
 adjusting the outline emphasis 38
 adjusting the position 37
 attaching 37
 cleaning 167
 detaching 37
 setting 137
 status display 135
 status display on the screen 28,
 135
Viewfinder connector 28
Viewfinder fitting shoe 22
Viewfinder front-to-back positioning
 knob 22
Viewfinder left-to-right positioning
 ring 22
Volume adjustment 14

W

WARNING indicator 18
Warning indicator area 18
WHITE BAL switch 15
White balance
 adjusting 55
 ATW 56
 automatic adjustment 12
 memory indicator 29
 offset 141
WHITE page 114
WHITE SETTING page 120
WRR connector 23

Z

ZEBRA button 13
Zoom control connector 26
Zoom position indicator 28
Zoom ring 25
ZOOM switch 26

<http://www.sony.net/>

Sony Corporation