

SONY®

HD DIGITAL VIDEOCASSETTE RECORDER

SRW-5000

SRW-5500

FORMAT CONVERTER BOARD
HKSR-5001

DIGITAL BETACAM PROCESSOR BOARD
HKSR-5002

RGB PROCESSOR BOARD
HKSR-5003

The supplied CD-ROM includes operation manuals for the SRW-5000/
SRW-5500 HD Digital Videocassette Recorders (English, Japanese,
French and German versions).
For more details, see "1-3 Using the CD-ROM Manual" on page 15.

HDCAM SR™ **HDCAM**

Tele-File 

OPERATION MANUAL English
1st Edition (Revised 10)

Important Safety Instructions

- Read these instructions.
- Keep these instructions.
- Heed all warnings.
- Follow all instructions.
- Do not use this apparatus near water.
- Clean only with dry cloth.
- Do not block any ventilation openings.
Install in accordance with the manufacturer's instructions.
- Do not install near any heat sources such as radiators, heat registers, stoves, or other apparatus (including amplifiers) that produce heat.
- Do not defeat the safety purpose of the polarized or grounding-type plug. A polarized plug has two blades with one wider than the other. A grounding-type plug has two blades and a third grounding prong. The wide blade or the third prong are provided for your safety. If the provided plug does not fit into your outlet, consult an electrician for replacement of the obsolete outlet.
- Protect the power cord from being walked on or pinched particularly at plugs, convenience receptacles, and the point where they exit from the apparatus.
- Only use attachments/accessories specified by the manufacturer.
- Use only with the cart, stand, tripod, bracket, or table specified by the manufacturer, or sold with the apparatus.

When a cart is used, use caution when moving the cart/apparatus combination to avoid injury from tip-over.
- Unplug this apparatus during lightning storms or when unused for long periods of time.
- Refer all servicing to qualified service personnel. Servicing is required when the apparatus has been damaged in any way, such as power-supply cord or plug is damaged, liquid has been spilled or objects have fallen into the apparatus, the apparatus has been exposed to rain or moisture, does not operate normally, or has been dropped.

WARNING

To prevent fire or shock hazard, do not expose the unit to rain or moisture.

To avoid electrical shock, do not open the cabinet. Refer servicing to qualified personnel only.

THIS APPARATUS MUST BE EARTHED.

AVERTISSEMENT

Afin d'éviter tout risque d'incendie ou d'électrocution, ne pas exposer cet appareil à la pluie ou à l'humidité.

Afin d'écarter tout risque d'électrocution, garder le coffret fermé. Ne confier l'entretien de l'appareil qu'à un personnel qualifié.



CET APPAREIL DOIT ÊTRE RELIÉ À LA TERRE.

WARNUNG

Um Feuergefahr und die Gefahr eines elektrischen Schlages zu vermeiden, darf das Gerät weder Regen noch Feuchtigkeit ausgesetzt werden.

Um einen elektrischen Schlag zu vermeiden, darf das Gehäuse nicht geöffnet werden. Überlassen Sie Wartungsarbeiten stets nur qualifiziertem Fachpersonal.

DIESES GERÄT MUSS GEERDET WERDEN.

	CAUTION RISK OF ELECTRIC SHOCK DO NOT OPEN	
CAUTION: TO REDUCE THE RISK OF ELECTRIC SHOCK, DO NOT REMOVE COVER (OR BACK). NO USER-SERVICEABLE PARTS INSIDE. REFER SERVICING TO QUALIFIED SERVICE PERSONNEL.		



This symbol is intended to alert the user to the presence of uninsulated “dangerous voltage” within the product’s enclosure that may be of sufficient magnitude to constitute a risk of electric shock to persons.



This symbol is intended to alert the user to the presence of important operating and maintenance (servicing) instructions in the literature accompanying the appliance.

WARNING: THIS WARNING IS APPLICABLE FOR USA ONLY.

If used in USA, use the UL LISTED power cord specified below.

DO NOT USE ANY OTHER POWER CORD.

Plug Cap	Parallel Blade with ground pin (NEMA 5-15P Configuration)
Cord	Type SJT, three 16 or 18 AWG wires
Length	Minimum 1.5 m (4 ft 11 in), less than 2.5 m (8 ft 3 in)
Rating	Minimum 10 A, 125 V

Using this unit at a voltage other than 120 V may require the use of a different line cord or attachment plug, or both. To reduce the risk of fire or electric shock, refer servicing to qualified service personnel.

WARNING: THIS WARNING IS APPLICABLE FOR OTHER COUNTRIES.

1. Use the approved Power Cord (3-core mains lead)/Appliance Connector/Plug with earthing-contacts that conforms to the safety regulations of each country if applicable.
2. Use the Power Cord (3-core mains lead)/Appliance Connector/Plug conforming to the proper ratings (Voltage, Ampere).

If you have questions on the use of the above Power Cord/ Appliance Connector/Plug, please consult a qualified service personnel.

AVERTISSEMENT

1. Utilisez un cordon d’alimentation (câble secteur à 3 fils)/fiche femelle/fiche mâle avec des contacts de mise à la terre conformes à la réglementation de sécurité locale applicable.

2. Utilisez un cordon d’alimentation (câble secteur à 3 fils)/fiche femelle/fiche mâle avec des caractéristiques nominales (tension, ampérage) appropriées.

Pour toute question sur l’utilisation du cordon d’alimentation/fiche femelle/fiche mâle ci-dessus, consultez un technicien du service après-vente qualifié.

WARNUNG

1. Verwenden Sie ein geprüftes Netzkabel (3-adriges Stromkabel)/einen geprüften Geräteanschluss/einen geprüften Stecker mit Schutzkontakten entsprechend den Sicherheitsvorschriften, die im betreffenden Land gelten.
2. Verwenden Sie ein Netzkabel (3-adriges Stromkabel)/ einen Geräteanschluss/einen Stecker mit den geeigneten Anschlusswerten (Volt, Ampere).

Wenn Sie Fragen zur Verwendung von Netzkabel/ Geräteanschluss/Stecker haben, wenden Sie sich bitte an qualifiziertes Kundendienstpersonal.

CAUTION

The apparatus shall not be exposed to dripping or splashing. No objects filled with liquids, such as vases, shall be placed on the apparatus.

ATTENTION

Eviter d’exposer l’appareil à un égouttement ou à des éclaboussures. Ne placer aucun objet rempli de liquide, comme un vase, sur l’appareil.

VORSICHT

Das Gerät ist nicht tropf- und spritzwassergeschützt. Es dürfen keine mit Flüssigkeiten gefüllten Gegenstände, z. B. Vasen, darauf abgestellt werden.

CAUTION

The unit is not disconnected from the AC power source (mains) as long as it is connected to the wall outlet, even if the unit itself has been turned off.

ATTENTION

Cet appareil n’est pas déconnecté de la source d’alimentation secteur tant qu’il est raccordé à la prise murale, même si l’appareil lui-même a été mis hors tension.

VORSICHT

Solange das Netzkabel an eine Netzsteckdose angeschlossen ist, bleibt das Gerät auch im ausgeschalteten Zustand mit dem Stromnetz verbunden.

For the customers in the U.S.A. (for SRW-5000/5500)

This equipment has been tested and found to comply with the limits for a Class A digital device, pursuant to Part 15 of the FCC Rules. These limits are designed to provide reasonable protection against harmful interference when

the equipment is operated in a commercial environment. This equipment generates, uses, and can radiate radio frequency energy and, if not installed and used in accordance with the instruction manual, may cause harmful interference to radio communications. Operation of this equipment in a residential area is likely to cause harmful interference in which case the user will be required to correct the interference at his own expense.

You are cautioned that any changes or modifications not expressly approved in this manual could void your authority to operate this equipment.

All interface cables used to connect peripherals must be shielded in order to comply with the limits for a digital device pursuant to Subpart B of Part 15 of FCC Rules.

Do not install the appliance in a confined space, such as book case or built-in cabinet.

Ne pas installer l'appareil dans un endroit confiné, par exemple une bibliothèque ou un placard encastré.

Das Gerät nicht an Orten aufstellen, z.B. in Bücherregalen oder Einbauschränken, wo keine ausreichende Belüftung gewährleistet ist.

For the customers in Europe (for SRW-5000/5500)

This product with the CE marking complies with both the EMC Directive and the Low Voltage Directive issued by the Commission of the European Community.

Compliance with these directives implies conformity to the following European standards:

- EN60065: Product Safety
- EN55103-1: Electromagnetic Interference (Emission)
- EN55103-2: Electromagnetic Susceptibility (Immunity)

This product is intended for use in the following Electromagnetic Environment: E4 (controlled EMC environment, ex. TV studio).

Pour les clients en Europe (pour SRW-5000/5500)

Ce produit portant la marque CE est conforme à la fois à la Directive sur la compatibilité électromagnétique (EMC) et à la Directive sur les basses tensions émises par la Commission de la Communauté Européenne.

La conformité à ces directives implique la conformité aux normes européennes suivantes:

- EN60065: Sécurité des produits
- EN55103-1: Interférences électromagnétiques (émission)
- EN55103-2: Sensibilité électromagnétique (immunité)

Ce produit est prévu pour être utilisé dans les environnements électromagnétiques suivants: E4 (environnement EMC contrôlé ex. studio de télévision).

Für Kunden in Europa (für SRW-5000/5500)

Dieses Produkt besitzt die CE-Kennzeichnung und erfüllt die EMV-Richtlinie sowie die Niederspannungsrichtlinie der EG-Kommission.

Angewandte Normen:

- EN60065: Sicherheitsbestimmungen

- EN55103-1: Elektromagnetische Vertraglichkeit (Störaussendung)

- EN55103-2: Elektromagnetische Vertraglichkeit (Störfestigkeit),

für die folgenden elektromagnetischen Umgebungen: E4 (kontrollierter EMV-Bereich, z.B. Fernsehstudio).

For the customers in Europe (for HKSR-5001/5002/5003)

This product with the CE marking complies with the EMC Directive issued by the Commission of the European Community.

Compliance with this directive implies conformity to the following European standards:

- EN55103-1: Electromagnetic Interference(Emission)
- EN55103-2: Electromagnetic Susceptibility(Immunity)

This product is intended for use in the following Electromagnetic Environment: E4 (controlled EMC environment, ex. TV studio)

Pour les clients en Europe (pour HKSR-5001/5002/5003)

Ce produit portant la marque CE est conforme à la Directive sur la compatibilité électromagnétique (EMC) émise par la Commission de la Communauté européenne. La conformité à cette directive implique la conformité aux normes européennes suivantes:

- EN55103-1: Interférences électromagnétiques (émission)
- EN55103-2: Sensibilité électromagnétique (immunité)

Ce produit est prévu pour être utilisé dans l'environnement électromagnétique suivant: E4 (environnement EMC contrôlé, ex. studio de télévision)

Für Kunden in Europa (für HKSR-5001/5002/5003)

Dieses Produkt besitzt die CE-Kennzeichnung und erfüllt die EMV-Richtlinie der EG-Kommission.

Angewandte Normen:

- EN55103-1: Elektromagnetische Verträglichkeit (Störaussendung)
- EN55103-2: Elektromagnetische Verträglichkeit (Störfestigkeit)

Für die folgende elektromagnetische Umgebung: E4 (kontrollierter EMV-Bereich, z.B. Fernsehstudio)

For the customers in Europe

The manufacturer of this product is Sony Corporation, 1-7-1 Konan, Minato-ku, Tokyo, Japan.

The Authorized Representative for EMC and product safety is Sony Deutschland GmbH, Hedelfinger Strasse 61, 70327 Stuttgart, Germany. For any service or guarantee matters please refer to the addresses given in separate service or guarantee documents.

This apparatus shall not be used in the residential area.

For the customers in Europe, Australia and New Zealand

WARNING

This is a Class A product. In a domestic environment, this product may cause radio interference in which case the user may be required to take adequate measures.

Pour les clients en Europe

Le fabricant de ce produit est Sony Corporation, 1-7-1 Konan, Minato-ku, Tokyo, Japon.

Le représentant autorisé pour EMC et la sécurité des produits est Sony Deutschland GmbH, Hedelfinger Strasse 61, 70327 Stuttgart, Allemagne. Pour toute question concernant le service ou la garantie, veuillez consulter les adresses indiquées dans les documents de service ou de garantie séparés.

Ne pas utiliser cet appareil dans une zone résidentielle.

Pour les clients en Europe, Australie et Nouvelle-Zélande

AVERTISSEMENT

Il s'agit d'un produit de Classe A. Dans un environnement domestique, cet appareil peut provoquer des interférences radio, dans ce cas l'utilisateur peut être amené à prendre des mesures appropriées.

Für Kunden in Europa

Der Hersteller dieses Produkts ist Sony Corporation, 1-7-1 Konan, Minato-ku, Tokyo, Japan.

Der autorisierte Repräsentant für EMV und Produktsicherheit ist Sony Deutschland GmbH, Hedelfinger Strasse 61, 70327 Stuttgart, Deutschland. Bei jeglichen Angelegenheiten in Bezug auf Kundendienst oder Garantie wenden Sie sich bitte an die in den separaten Kundendienst- oder Garantiedokumenten aufgeführten Anschriften.

Dieser Apparat darf nicht im Wohnbereich verwendet werden.

Für Kunden in Europa, Australien und Neuseeland

WARNUNG

Dies ist eine Einrichtung, welche die Funk-Entstörung nach Klasse A besitzt. Diese Einrichtung kann im Wohnbereich Funkstörungen verursachen; in diesem Fall kann vom Betreiber verlangt werden, angemessene Maßnahmen durchzuführen und dafür aufzukommen.

WARNING

Excessive sound pressure from earphones and headphones can cause hearing loss.

In order to use this product safely, avoid prolonged listening at excessive sound pressure levels.

AVERTISSEMENT

Une pression acoustique excessive en provenance des écouteurs ou du casque peut provoquer une baisse de l'acuité auditive.

Pour utiliser ce produit en toute sécurité, évitez l'écoute prolongée à des pressions sonores excessives.

WARNUNG

Zu hoher Schalldruck von Ohrhörern und Kopfhörern kann Gehörschäden verursachen.

Um dieses Produkt sicher zu verwenden, vermeiden Sie längeres Hören bei sehr hohen Schalldruckpegeln.

For the customers in the USA

Lamp in this product contains mercury. Disposal of these materials may be regulated due to environmental considerations. For disposal or recycling information, please contact your local authorities or the Electronic Industries Alliance (www.eiae.org).

For the customers in Taiwan only



廢電池請回收

Table of Contents

Chapter 1 Overview

1-1 Features	11
1-1-1 Features of the SRW-5000/SRW-5500.....	11
1-1-2 Features of the Control Panel.....	13
1-2 Optional Accessories	15
1-3 Using the CD-ROM Manual	15
1-3-1 Preparations.....	15
1-3-2 Reading the CD-ROM Manual	15

Chapter 2 Locations and Functions of Parts

2-1 Control Panel.....	16
2-1-1 Upper Control Panel	17
2-1-2 Lower Control Panel	18
2-1-3 System Set-Up Panel.....	24
2-2 Connector Panel	25

Chapter 3 Setting Up the VTR

3-1 Connecting External Equipment	30
3-1-1 Making HD Digital Connections	30
3-1-2 Making NTSC/PAL Digital Connections	31
3-1-3 Cascade Connection.....	32
3-2 Reference Signals.....	33
3-2-1 Reference Signals for Output Video	33
3-2-2 Reference Signal Connections	34
3-3 Handling Cassettes.....	35
3-3-1 Recommended Cassettes.....	35
3-3-2 Inserting and Ejecting Cassettes	35
3-3-3 Preventing Accidental Erasure.....	36
3-4 Using a “Memory Stick”	36
3-4-1 Notes on “Memory Stick”.....	36

Chapter 4 Menu Settings

4-1 Registering and Storing Menu Settings	38
4-1-1 Menu Configuration	38
4-1-2 Changing Menu Settings	38
4-1-3 Registering Items to the VTR SETUP Menu	39
4-1-4 VTR Memory Bank Function	40
4-1-5 “Memory Stick” Operations	42
4-1-6 Adding Titles to the Data	47
4-1-7 Details on VTR Memory Bank and “Memory Stick” Functions	47
4-1-8 “Memory Stick” Data Compatibility	48
4-1-9 Automatic Reading from a VTR Bank at Power On	49
4-1-10 Saving and Recalling DEFAULT Settings on a Bank ..	49
4-1-11 Saving and Recalling DEFAULT Settings in a “Memory Stick”	49
4-2 HOME Menu	51
4-2-1 Selecting the Output Signals (PB/EE)	52
4-2-2 Record Inhibit Mode (REC INH)	52
4-2-3 Selecting the Edit Mode and Edit Channel (ASSEMBLE, INS TC, INS VIDEO, INS AUDIO and INS CUE)	52
4-2-4 Preread Settings (PRE READ)	53
4-2-5 Still-Picture Output (FREEZE)	53
4-2-6 Setting the Preroll Time (PREROLL TIME)	53
4-2-7 Selecting DMC Playback (DMC)	53
4-2-8 Setting the Stop Code (STOP CODE)	54
4-3 TC Menu	57
4-3-1 Setting the Time Data (TIMER SEL/RESET/SET/HOLD)	58
4-3-2 Setting the Time Code Reader (TCR SEL)	61
4-3-3 Setting the Time Code Generator (TCG SOURCE/MODE)	61
4-3-4 Selecting the Time Code Running Mode (RUN MODE)	61
4-3-5 Selecting the Drop Frame Mode (DF/NDF)	62
4-3-6 Selecting the Content of the Second Time Code Display Area (TC2 SEL)	62
4-3-7 Selecting CTL Display Mode (TAPE TIMER)	62
4-3-8 Presetting Pulldown Time Code (PDPSET MENU) (when HKSR-5001 is installed)	62
4-3-9 Presetting for Conversion from Frame Time Code (TCCONV MENU)	63
4-3-10 Displaying the Pulldown Time Code (PDTC DISP) (when HKSR-5001 is installed)	65

4-3-11 Superimposition of Character Information (PD CHARA/ CHARA SUPER/H-POS/V-POS).....	65
4-4 CUE Menu	69
4-4-1 Selecting a Multi-Cue Mode.....	70
4-4-2 Registering Cue Points.....	70
4-4-3 Erasing Cue Point Data.....	72
4-4-4 Prerolling to a Cue Point.....	72
4-4-5 Changing a Cue Point Into an Edit Point.....	73
4-4-6 TELE FILE Menu	73
4-5 VIDEO Menu	88
4-5-1 Selecting the Reference Signal (SERVO REF)	89
4-5-2 Adjusting the Output Video Signal (MASTER to FINE)	89
4-6 AUDIO Menu	92
4-6-1 Selecting the Audio Input Signal (AUDIO IN)	93
4-6-2 Digital Audio Output Signal Source Track Selection (DIGOUT EXCHNG).....	93
4-6-3 Analog Audio Output Signal Source Track Selection (ANAOUT EXCHNG).....	94
4-6-4 Digital Audio Output Signal Source Track Selection (SDOUT EXCHNG).....	94
4-6-5 Audio Transition Type Selection for Digital Audio Editing (AUDIO EDIT)	95
4-6-6 Fade Processing Time Selection for Digital Audio Editing (FADE TIME).....	95
4-6-7 External Device Audio Edit Preset Command Replace Mode Selection (EDIT PRESET REPLACE CHANNEL SELECT).....	96
4-6-8 External Device Digital Audio Edit Preset Command Replace Mode Selection (AUDIO EDIT PRESET REPLACE).....	96
4-6-9 External Device Analog Audio Edit Preset Command Replace Mode Selection (ANALOG AUDIO EDIT REPLACE).....	97
4-6-10 PITCH GROUP Selection (PITCH CORRECTION GROUP SELECT)	97
4-7 SET UP Menu.....	98
4-7-1 VTR SETUP Menu	99
4-7-2 PANEL SETUP Menu	101

Chapter 5 Recording/Playback

5-1 Preparing for Recording.....	103
5-1-1 Setting Switches and Menus	103

5-1-2 Selecting Audio Signals	104
5-1-3 Adjusting the Recording Level	105
5-1-4 Simultaneously Monitoring Playback of Video and Audio Signals Being Recorded	106
5-1-5 Audio Level Meter Display Modes.....	106
5-2 Recording.....	107
5-3 Preparing for Playback	108
5-3-1 Setting Switches and Menus	108
5-3-2 Adjusting the Audio Playback Level	108
5-3-3 Selecting the HD-SD Conversion Mode	109
5-4 Playback.....	110
5-4-1 Normal-Speed Playback.....	110
5-4-2 Variable Speed Playback.....	110
5-4-3 Capstan Override Playback.....	112
5-4-4 DMC Playback.....	112
5-4-5 Playing Back Non-audio Data.....	113
5-4-6 Performing Program Play.....	114

Chapter 6 Editing

6-1 Basic Automatic Editing	116
6-1-1 Overview of Automatic Editing	116
6-1-2 Setting Switches and Menus	117
6-1-3 Selecting the Edit Mode	118
6-1-4 Setting Edit Points.....	118
6-1-5 Editing Non-audio Data	121
6-1-6 Confirming Edit Points	121
6-1-7 Cuing Up and Prerolling	122
6-1-8 Previewing.....	122
6-1-9 Modifying Edit Points	123
6-1-10 Performing Automatic Editing.....	125
6-2 Advanced Automatic Editing.....	127
6-2-1 DMC Editing	127
6-2-2 Animation Editing	128
6-2-3 Preread Editing.....	128
6-3 Manual Editing	130

Appendix

Maintenance	131
Head Cleaning.....	131

Moisture Condensation.....	131
Specifications.....	132
Error Messages and Warning Messages	135
Error Messages	135
Warning Messages.....	136
Error Log Menu	138
Glossary.....	140
Menu List	142
Items Relating to VTR Operations (Nos. 001 to ...).....	142
Items Relating to Operation Panels (Nos. 101 to ...).....	146
Items Relating to Remote Interface (Nos. 201 to ...).....	149
Items Relating to Editing (Nos. 301 to ...).....	150
Items Relating to Prerolling (Nos. 401 to ...)	153
Items Relating to Recording Protection (Nos. 501 to ...)	154
Items Relating to the Time Code (Nos. 601 to ...).....	156
Items Relating to the Video Control (Nos. 706 to ...).....	161
Items Relating to the Audio Control (Nos. 807 to ...)	165
Items Relating to Digital Processing (Nos. 902 to ...).....	175
Items Relating to the Pulldown Control (Nos. A01 to ...)	179
Other Items (Nos. T01 to ...).....	181
MPEG-4 Visual Patent Portfolio License.....	186
Index.....	187

1-1 Features

1-1-1 Features of the SRW-5000/ SRW-5500

The SRW-5000/SRW-5500 is a high-definition digital videocassette recorder using the HDCAM-SR format. It is a small and light unit incorporating LSIs for signal processing and is comparable to the HDCAM¹⁾ model HDW-F500 in size, weight and functionality. The SRW-5500 only is a recorder supporting both the HDCAM-SR and HDCAM formats.

1) HDCAM is a trademark of Sony Corporation.

HDCAM-SR format

The HDCAM-SR format exploits technological advances in signal processing and magnetic recording, to provide functionality comparable to that of the HDCAM format, while offering HD digital recording and playback with high image and sound quality.

The technology incorporated in this unit includes the following.

- Highly efficient and mild data compression using newly developed MPEG-4 Studio Profile
- Powerful error-correcting codes
- High-performance, high-accuracy heads and drum with dynamic tracking (DT™), together with a new auto-tracking technique, yielding highly reliable narrow track recording and playback.

These technologies allow 120 minutes of recording on an HDCAM-SR cassette (L type), the same size as the HDCAM cassette.

Digital signal processing

In this unit, 4:2:2 component video signals obtained by quantization according to ITU-R709, SMPTE 274M and BTA S-002B (SMPTE 260M) are compressed using MPEG-4 Studio Profile. Audio signals are processed uncompressed, according to the AES/EBU format.

Input interface

The input interface is based on the HD SDI (HD Serial Digital Interface) format specified by BTA S-004B/005B/006B (SMPTE 291M/292M/299M) and ARIB STD-B4, allowing a single BNC coaxial cable to carry one component video signal, twelve digital audio channels, and time code in time division multiplex; this is separated for conversion to parallel data.

Audio recording can be switched between the digital audio signal multiplexed with the HD SDI signal and the audio signal from an AES/EBU digital interface.

Bit rate reduction encoder

The component video signal undergoes frame shuffling. It is then compressed by a process in which it is subjected to DCT (discrete cosine transform) or DPCM (differential pulse code modulation), quantization control, and variable length word encoding. This is the core of the newly developed MPEG-4 Studio Profile. Interlaced signals are compressed in fields and progressive signals are compressed in frames.

ECC encoder

The outer ECC (Error Correction Code) is added to the compressed video and audio data, followed by the inner ECC, ID data, and sync data. Reed-Solomon codes are employed in this error correction system.

Channel coding

Video and audio data with the ECC added is recorded in the form of serial data. The HDCAM-SR format adopts a scrambled i-NRZ channel coding system, giving consideration to off-track and noise characteristics.

Playback signal processing

The playback digital signal is equalized by an equalizer circuit. It then passes powerful inner and outer ECCs which can correct dropouts in the reproduced signal. It further goes through an error concealment circuit to have errors still remaining in the signal rectified.

Output interface

Component video data is converted into serial data and multiplexed with audio data and time code, then output in the HD SDI format.

With an HD-SD converter board installed, the unit can output both D1 SDI and analog composite signals. Besides audio data is output as digital data multiplexed with the HD SDI signal, it is also output via an AES/EBU digital interface. Analog data converted from digital data is also provided.

HDCAM format

The HDCAM format uses tape with the same 12.65 mm width as the Betacam series to enable recording of up to two hours of high-quality HD video. Video signal compression uses prefilter and coefficient recording technology.

Advanced recording and playback functions

High-quality digital recording

This unit uses a component system to record video signals. An AES/EBU format with a wide dynamic range is used for 12-channel audio recording. A unique and powerful error correction circuit and concealment circuit are used in digital signal processing. Accurate and stable video signal output is made possible by setting and adjusting the internal digital video processor.

Record/playback modes

HDCAM-SR format (SRW-5000/5500) or HDCAM format (SRW-5500)

As the record/playback mode, you can select from the following nine modes.

1080×1920: 59.94i/60i/50i/23.98PsF/24PsF/25PsF/29.97PsF/30PsF

720×1280: 59.94P/50P (HDCAM-SR format only)

Playback compatibility

You can select the following compatibility playback functions.

- HDCAM (SRW-5000)
1080×1920: 59.94i/60i/50i/23.98PsF/24PsF/25PsF/29.97PsF/30PsF
- Digital Betacam
525/59.94i, 625/50i

However, Digital Betacam playback requires the HKSR-5002 (option).

Internal format conversion function

By installing an optional HKSR-5001, when the operation mode of this unit is 23.98PsF or 24PsF, a 59.94i or 60i mode HD SDI output (audio/VITC multiplex) is made available. Additionally, conversion in either direction between 1080×1920 and 720×1280, and conversion from 4:2:2 signal to 4:4:4 signal is possible, and with the additional installation of an HKSR-5003, conversion from a 4:4:4 signal to a 4:2:2 signal.

Noiseless playback with DT heads

When using the HDCAM-SR or HDCAM format, the dedicated playback DT heads allow you to perform noiseless playback in the range from -1 to +2 times normal speed, including still-picture playback. When using the Digital Betacam format, the playback range is from -1 to +3. However, Digital Betacam playback requires the HKSR-5002 (option).

Video and audio confidence heads

Video and audio (channels 1 through 12, or 4 channels for the HDCAM format (SRW-5500 only)) signals can be recorded and simultaneously played back to check the recording.

Internal time code generator and reader

The internal time code generator allows you to record time code (LTC or user bits) together with video and audio signals. Time codes (LTC or user bits) can be read during playback using the time code reader.

Computer servo system

Computer-controlled servo motors provide direct drive for the drum, capstan, and two reels, enabling quick and accurate tape access.

Capstan override function

You can adjust the playback speed by $\pm 15\%$ to ensure synchronization between, for example, two VTRs playing back the same program.

Independent audio level control

It is possible to adjust the recording and playback levels either independently on each channel or simultaneously on all 12 channels (or 4 channels for HDCAM format (SRW-5500 only)) while monitoring the peak values.

Tele-File¹⁾ memory label system

This unit incorporates the Tele-File memory label system to allow users to read, write and update videocassette management information, log data (IN/OUT points) and cue point data on memory labels, providing greater efficiency in cassette management and editing.

1) Tele-File

A contact-free system for writing, reading, and modifying video cassette-related information on IC memory-bearing labels. Tele-File is a trademark of Sony Corporation.

Program Play (P-PLAY) Function/Pitch Correction Function

Program play is a function that allows play at $\pm 5\%$ of normal speed. Pitch correction of the audio is possible at the same time.

This function is available only for the combination of SRW-5000/5500 Serial No. 12001 or higher and HKSR-5001 Serial No. 11001 or higher.

Features for ease of operation

Compact, lightweight, low power consumption

The VTR is small and light enough to be used in outside broadcast vans or in EFP (Electronic Field Production) assignments.

Remote control operation

The VTR has a serial RS-422A 9-pin connector to allow control of the VTR by an external control unit. The VTR also comes with 9-pin REMOTE 1-IN(9P) and REMOTE 1-I/O(9P) connectors to support bridge connection of multiple SRW-5000/5500 units or other VTRs equipped with 9-pin remote connectors for simultaneous operation. Furthermore, you can control the VTR from an external control unit with a parallel (50-pin) interface.

Digital hours meter

The meter can show the total elapsed time since the VTR was turned on, total drum revolution time, total tape running time and total number of threadings and unthreadings.

Self-diagnosis

This function allows the VTR to perform self diagnostics when a malfunction occurs. An error message is displayed and a history of all errors that have occurred is recorded.

Easy-to-maintain plug-in boards

The VTR uses plug-in circuit boards to simplify servicing and inspection.

Mountable in standard 19-inch rack

The unit can be mounted in an EIA-standard 19-inch rack.

For rack mounting, refer to the Installation Manual.

1-1-2 Features of the Control Panel

The control panel provides eight menu screens corresponding to different operation modes to allow fast and easy adjustment of necessary settings, as well as the ability to store menu settings to a “Memory Stick” for later recall.

Menu-driven operations for a variety of purposes

Eight menus are displayed on the 130 × 95 mm (5 ¹/₈ inches × 3 ³/₄ inches) color display and are set using the 10 function buttons.

You can register desired items to the menus other than the SET UP menu.

Pressing the **[F4]** (PF ASSIGN) button in the SET UP menu displays the menu items that can be registered.

HOME menu

Use this menu to make the basic settings for recording, playback, and editing operations, and to select channels to be edited during insert editing.

TC menu

Use this menu to make time code settings.

VIDEO menu

Use this menu to adjust the video signals. The VIDEO menu screen shows the VTR operation mode, current position time code, time code type, and so on.

AUDIO menu

Use this menu to adjust the audio signals. The AUDIO menu screen shows the VTR operation mode, current position time code, time code type, and so on.

CUE menu

Use this menu to set up to 100 cue points. In page mode, 10 cue points per page can be set on a total of 10 pages. In the TELE FILE menu, you can change the setting for the memory label system Tele-File.

PF1/PF2 (Personal Function) menus

Use these menus to register up to 40 of the most frequently used items from the other menus (up to 10 items each can be registered to PF1, ALT/PF1, PF2 and ALT/PF2).

SET UP menu

This menu enables the following settings.

- The VTR BANK menu allows up to eight pages of menu settings to be saved.
- Use the MEMORY CARD menu to store current settings of the VTR and up to eight pages of the contents of the VTR memory bank to a “Memory Stick”.
- Use the scrollable PF ASSIGN menu to display the items that can be registered, and to select and register the most frequently used menu items.
- Use the scrollable VTR SETUP menu to display the items necessary for making initial settings, and to directly change settings without registering them with the function buttons for each menu.
- Use the PANEL SETUP menu to set control panel operations, such as the keyboard sound output.

MAINTENANCE menu

Use this menu to access the maintenance functions.

For details, refer to the Maintenance Manual Volume 1.

A full complement of storage/recall functions

These functions allow you to use titles to store and recall menu settings in either the VTR’s internal memory banks or “Memory Sticks”.

VTR memory banks

These memory banks allow you to store up to eight pages of VTR settings in addition to the current VTR settings. Factory settings are also stored here, allowing the VTR to be reset to these values at any time.

“Memory sticks”

Each “Memory Stick” can hold the current VTR settings as well as up to eight pages of settings. A single “Memory Stick” thus allows you to store and recall the entire contents of the VTR memory banks.

Title function

This function allows you to add titles when storing data to the VTR memory bank or “Memory Stick”, thus facilitating data retrieval and management.

Write protect function

Setting pages stored in VTR memory banks or “Memory Sticks” can be write protected on an individual basis.

A full range of editing functions

Two SRW-5000/5500 units can be connected allowing automatic or manual assemble and insert editing. The VTR also features a full range of editing functions, including preview, review, preroll, and the setting or changing of edit points.

Quick access to edit points

The following methods are provided for the setting of edit points:

- Multi-cuing for up to 100 edit points
- Search dial with shuttle and jog functions
- Direct input through numeric buttons

DMC (Dynamic Motion Control) editing

Using the DT[®] (Dynamic Tracking) heads, you can play back a section of an edit at speeds between -1 and +2 times normal speed and store the speed variation in memory for later use in automatic editing.

Split editing

In insert mode, audio and video edit points can be set separately.

Preread editing

Video and audio signals that have been pre-read can be externally processed and simultaneously re-recorded.

A variety of audio editing modes

You can select cut-in editing, cross-fade editing, and fade in/out editing for the audio signals.

Display of duration between edit points

The duration between any two of IN, OUT, AUDIO IN, or AUDIO OUT points can be displayed by simultaneously pressing two buttons corresponding to those edit points.

Digital time counter

The time counter display shows CTL and time codes (LTC/VITC¹), or user bits data for precise setting of edit points.

1) LTC (Longitudinal Time Code):

Time code recorded on a longitudinal track

VITC (Vertical Interval Time Code):

Time code recorded on a video track during the vertical blanking interval

1-2 Optional Accessories

The following accessories can be used with this unit.

HKSR-5001 Format Converter Board

This allows format conversion described below:

- 2-3 pulldown (23.98PsF to 59.94i, 24PsF to 60i)
- Conversion between 1080 and 720P
- 4:2:2 between 4:4:4
(Conversion of 4:4:4 to 4:2:2 is possible only when the HKSR-5003 is additionally installed.)

HKSR-5002 Digital Betacam Processor Board

This allows you to play back Digital Betacam tapes and output SD and HD signals.

When the system is operated in 4:4:4 mode, up conversion of the output to HD signals are possible as follows, depending on the system setting.

1080: Up conversion to 1080.

720: Up conversion to 720P.

When the system is operated in 4:4:4 mode, no up-converted HD output can be obtained.

HKSR-5003 RGB Processor Board

This allows you to accept dual link HD SDI input, and record and play back RGB (4:4:4).

HKDV-900 HD Digital Video Controller

This allows you to remotely control the parameters for video signals and image enhancement.

References

In addition to this Operation Manual, the following manuals are available:

Maintenance Manual Volume 1 (optional)

Provides detailed information necessary to maintain the VTR.

Maintenance Manual Volume 2 (optional)

Provides information on spare parts.

Maintenance Manual Volume 3 (optional)

Contains circuit diagrams and block diagrams.

Installation Manual (supplied)

Provides necessary information to install and operate the VTR.

For information about changing the video system, refer to "1-11. System Setting" in the Installation Manual.

9-pin Protocol Manual (optional)

Provides information on the 9-pin protocol.

1-3 Using the CD-ROM Manual

The supplied CD-ROM includes operation manuals for this unit (English, Japanese, French and German versions).

1-3-1 Preparations

The following program must be installed on your computer in order to read the operations manuals contained on the CD-ROM.

- Adobe Reader Version 6.0 or higher

If Adobe Reader is not installed, you can download it from the following URL:

<http://www.adobe.com/>

Adobe and Adobe Reader are trademarks of Adobe Systems Incorporated in the United States and/or other countries.

1-3-2 Reading the CD-ROM Manual

To read the operation manuals contained on the CD-ROM, do the following.

- 1 Insert the CD-ROM in your CD-ROM drive.

A cover page appears automatically in your browser. If it does not appear automatically in the browser, double-click on the index.htm file on the CD-ROM.

- 2 Select and click on the operations manuals that you want to read.

This opens the PDF file of the operation manuals.

The files may not be displayed properly, depending on the version of Acrobat Reader. In such a case, install the latest version you can download from the URL mentioned in 1-3-1 "Preparations" above.

Note

If you have lost or damaged the CD-ROM, you can purchase a new one to replace it. Contact your Sony service representative.

Locations and Functions of Parts

Chapter

2

2-1 Control Panel

The control panel consists of the following sections:

- Upper control panel

- Lower control panel
- System set-up panel

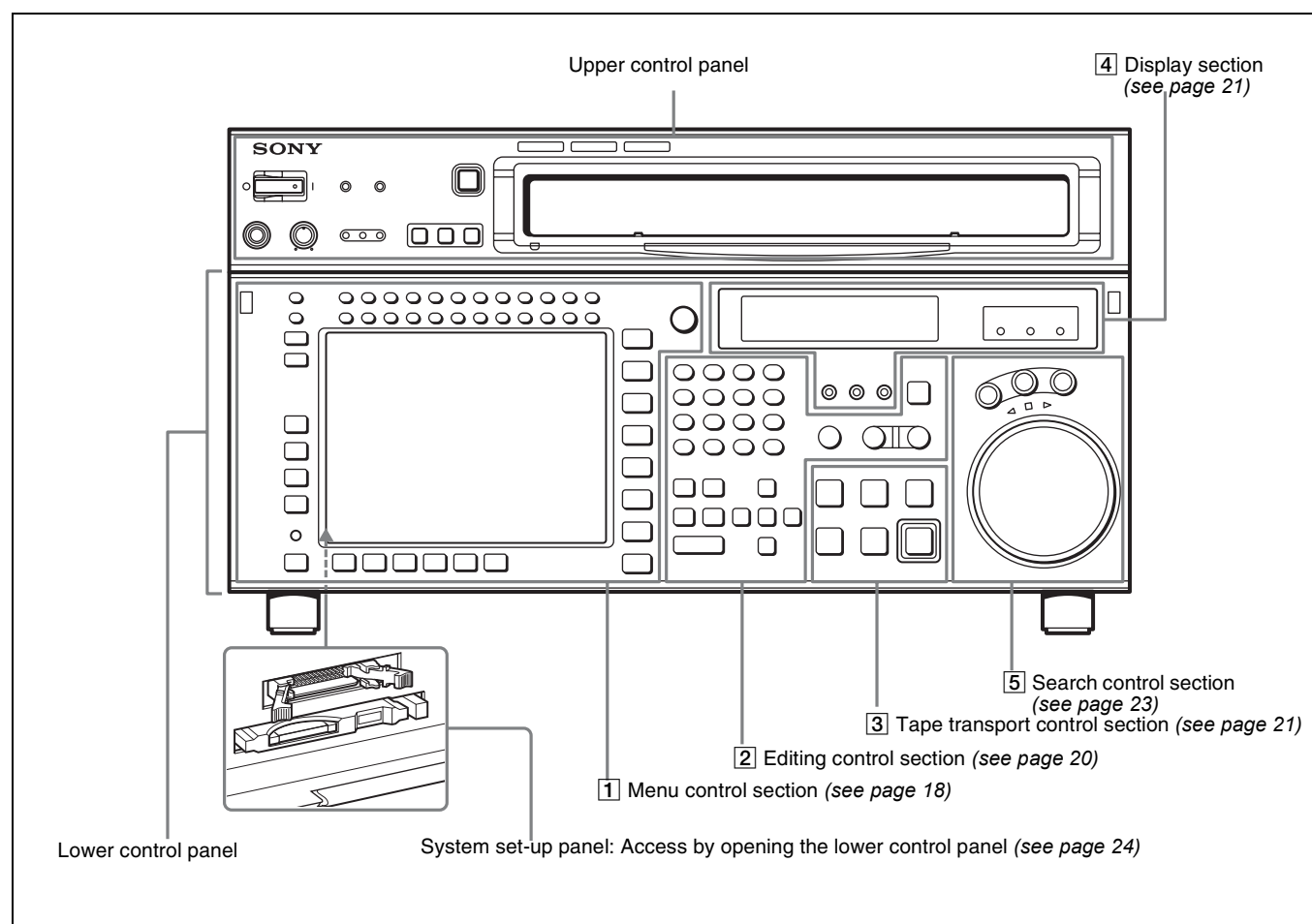

Note

Normally operate the unit with the control panel closed.

For details of how to open the control panel, for example for system setup, refer to the Maintenance Manual.

2-1-1 Upper Control Panel

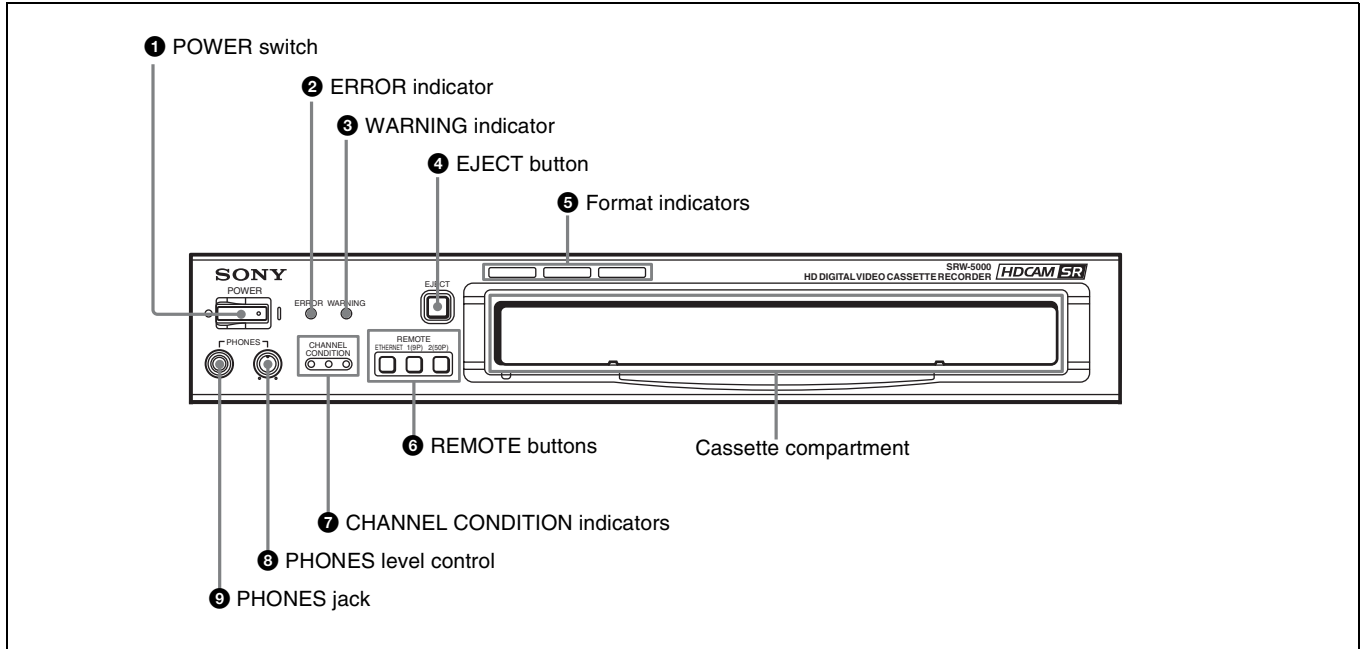

1 POWER switch

Pressing on the 'I' side of this switch powers the unit and lights up the information display (see page 21) and color display (see page 18). To turn the unit off, press on the 'O' side of the switch.

2 ERROR indicator

This lights when a serious problem occurs, such as an operational malfunction or system internal error. You can check the details on the lower control panel.

For details, see "Error Messages and Warning Messages" on page 135.

3 WARNING indicator

This flashes when there is a fault in the unit. You can check the details on the lower control panel.

For details, see "Error Messages and Warning Messages" on page 135.

4 EJECT button

Pressing this button automatically ejects the cassette after several seconds.

5 Format indicators (Digital BETACAM/HDCAM/HDCAM SR)

These show the format of the cassette loaded into the unit.

6 REMOTE buttons

Press one of the following buttons, to select how the VTR is controlled.

ETHERNET: This button lights when pressed, enabling access from the network connected to the ETHERNET connector on this unit.

1(9P): This button lights when pressed, enabling this unit to be controlled from a device connected to the REMOTE 1-IN(9P) connector or REMOTE 1-I/O(9P) connector.

2(50P): This button lights when pressed, enabling this unit to be controlled from a device connected to the REMOTE 2 PARALLEL I/O(50P) connector.

Note

When the VTR is being controlled by the external equipment connected to the REMOTE 1-IN(9P) or REMOTE 2 PARALLEL I/O(50P) connector, all tape transport buttons and edit operation buttons are disabled, except the STOP and EJECT buttons. You may also specify the disabling or enabling of all buttons by setting the VTR SETUP menu item 008 "LOCAL FUNCTION ENABLE".

7 CHANNEL CONDITION indicators

These show the status of the playback signal.

Blue: The playback signal status is satisfactory.

Yellow: The playback signal is somewhat degraded, but playback is possible.

However, if this indicator remains lit continuously, head cleaning is required.

Red: The playback signal has deteriorated.

If this indicator remains lit continuously, head cleaning or internal inspection is required.

8 PHONES level control

Adjusts the output level to the PHONES jack.

For details, see “5-1-2 Selecting Audio Signals” on page 104.

9 PHONES jack

Connect stereo headphones with 8 Ω impedance for audio monitoring during recording, playback, and editing. Adjust the headphone output level with the PHONES level control.

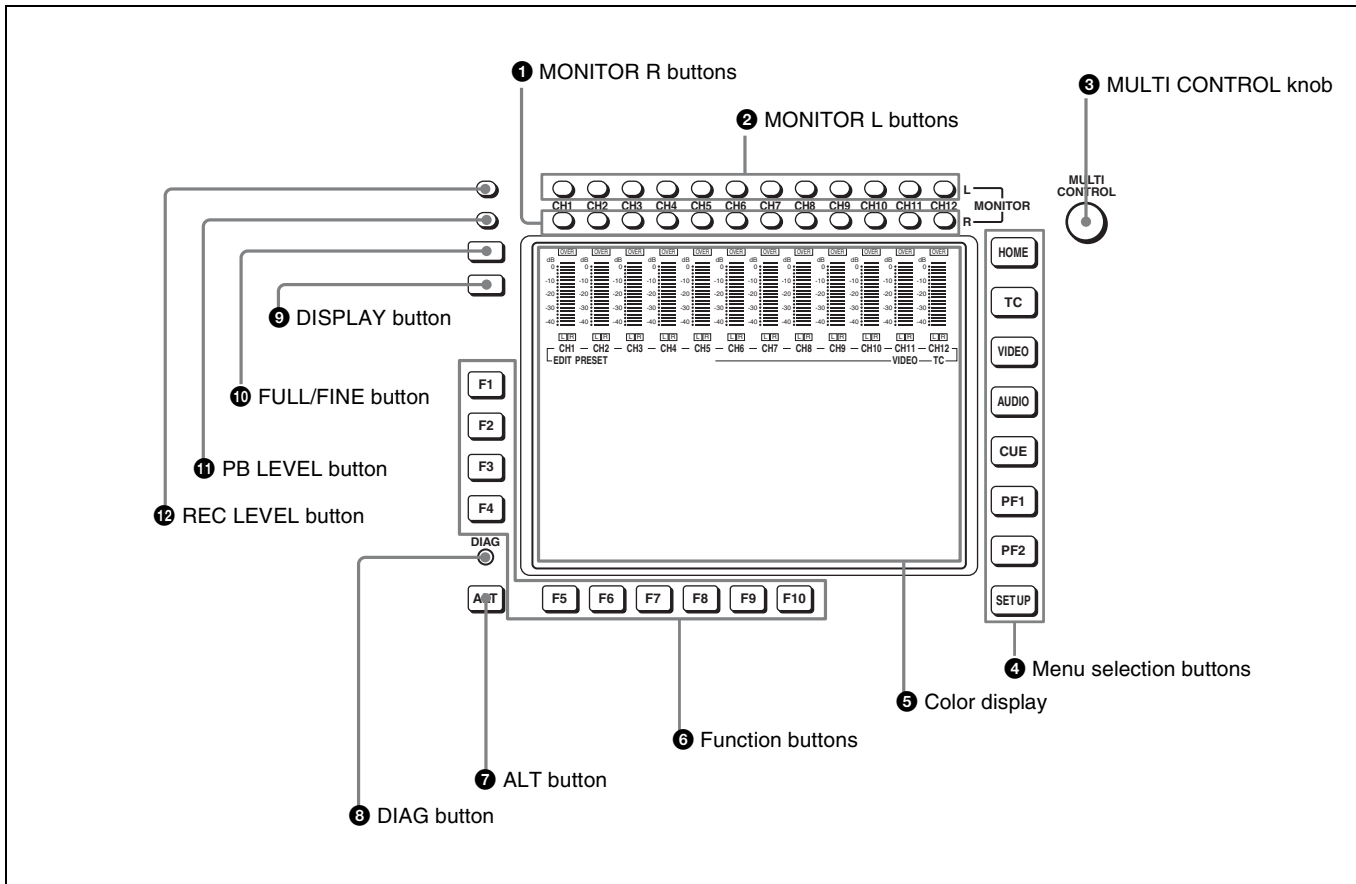
2-1-2 Lower Control Panel**1 Menu control section****1 MONITOR R buttons**

Select the audio signal output from the MONITOR OUTPUT R connector. This assigns the desired channel to the MONITOR OUTPUT R connector. If you assign more than one channel to the same monitor output connector, a mixed audio signal is output.

You can also make this setting using the VTR SETUP menu item 808 “AUDIO MONITOR-R select”. In the audio playback level adjustment mode, this is used to select the channel to be adjusted.

2 MONITOR L buttons

Select the audio signal output from the MONITOR OUTPUT L connector. This assigns the desired channel to the MONITOR OUTPUT L connector. If you assign more than one channel to the same monitor output connector, a mixed audio signal is output.

You can also make this setting using the VTR SETUP menu item 807 “AUDIO MONITOR-L select”. In the audio playback level adjustment mode, this is used to select the channel to be adjusted.

3 MULTI CONTROL knob

Used to set the audio recording/playback level and make settings in the SET UP menu (*see page 98*).

4 Menu selection buttons

These select the menu screen displayed on the display.
HOME button: Press this to go to the HOME menu screen. The home menu provides settings for the basic VTR operations and editing operations.

TC button: Press this to go to the TC (time code) menu screen. In the time code menu, you can switch LTC/

VITC, switch DF/NDF, set the time code to be displayed on an external monitor, and so on.

VIDEO button: Press this to go to the VIDEO menu screen. Use it to make video related settings.

AUDIO button: Press this to go to the AUDIO menu screen. Use it to make audio related settings.

CUE button: Press this to go to the CUE menu screen. The cue menu provides 10 pages to set cue points. You can set up to 10 cue points per page. You can also make settings for the Tele-File memory label system.

PF1 button: Press this to go to the PF1 (personal function 1) menu screen. You can register frequently-used items in the PF1 menu. The factory default setting is blank.

PF2 button: Press this to go to the PF2 (personal function 2) menu screen. You can register frequently-used items in the PF2 menu. The factory default setting is blank.

SET UP button: Press this to go to the SET UP menu screen. The setup menu provides functions to save menu settings in VTR banks or save to a “Memory Stick”, registration operations in the PF buttons, VTR SETUP menu settings, and so on.

For details of menus, see Chapter 4 “Menu Settings” on page 38.

5 Color display

This comprises principally the audio level display and menu display.

Audio Level display:

In recording mode or E-E mode¹⁾, this displays the audio recording levels.

In playback mode or CONF1 mode, this displays the playback levels.

The display mode can be changed with the FULL/FINE button. The factory default display is a reference level of -20 dB, and peak level 0 dB.

Menu display:

This displays the menu screen selected by the menu selection buttons.

Each menu screen shows the functions assigned to the function buttons (F1 to F10), and shows simultaneously information required for time code display settings and so on.

1) E-E mode

An abbreviation for Electric-to-Electric mode. In this mode, video or audio input signals are passed and output only through the VTR's internal circuitry, and not through the magnetic conversion system comprising tape and heads.

Note on faulty pixels on the LCD panel

The LCD panel fitted to this unit is manufactured with high precision technology, giving a functioning pixel ratio of at least 99.99%. Thus a very small proportion of pixels maybe “stuck”, either always off (black), always on (red, green, or blue), or flashing. In addition, over a long period of use, because of the physical characteristics of the liquid crystal display, such “stuck” pixels may appear spontaneously. These problems are not a malfunction. Note that any such problems have no effect on recorded data.

6 Function buttons

Activates the functions in each menu.

7 ALT (alternative) button

Press to change the items displayed on the current menu. Press again to return to the original items.

8 DIAG (diagnostic) button

Hold down the SFT button (*see page 20*) in the editing control section and press this switch to switch to the DIAG menu.

9 DISPLAY button

This displays the down-converted output signal in the whole color display.

Notes

- Depending on the system settings, it may not be possible to output some signals.
- This function is for a quick check of the output signal, and cannot be used as a monitor.

10 FULL/FINE button

This selects the audio level meter display range.

FULL: The audio level meter display is from -60 dB to 0 dB, or -40 dB to +20 dB. Select which of these ranges (peak level: 0 dB or +20 dB) is displayed in the VTR SETUP menu item 814 “LEVEL METER SCALE”.

FINE: The audio level meter display range is expanded, and displayed with a scale in steps of 0.25 dB. The reference marker LED at the center of the level meter display range lights. When the audio level exceeds the maximum display range, the top line flashes. When under the minimum display range, the bottom line flashes.

11 PB (playback) LEVEL button

Press this button to enter the playback audio level adjustment mode. In this mode, you can use the MONITOR R button to select the adjustment target channels from channels 1 to 12. While watching the audio level meter, turn the MULTI CONTROL knob for a desired audio level.

Clicking the MULTI CONTROL knob resets the playback audio level to the factory set level (a reference level of 0 dB is displayed for a +4 dBm input). Clicking the MULTI CONTROL knob again restores the adjusted level. Press this button again to exit from the playback audio level adjustment mode, and the MONITOR L and R buttons return to the normal status (this status is called the “MONITOR SELECT mode”).

12 REC (recording) LEVEL button

Press this button to enter the recording audio level adjustment mode. In this mode, you can use the MONITOR L button to select the adjustment target channels from channels 1 to 12. While watching the audio level meter, turn the MULTI CONTROL knob for a desired audio level.

Clicking the MULTI CONTROL knob resets the recording audio level to the factory set level (a reference level of 0 dB is displayed for a +4 dBm input). Clicking the MULTI CONTROL knob again restores the adjusted level. Press this button again to exit from the recording audio level adjustment mode, and the MONITOR L and R buttons return to the normal status (this status is called the “MONITOR SELECT mode”).

2 Editing control section

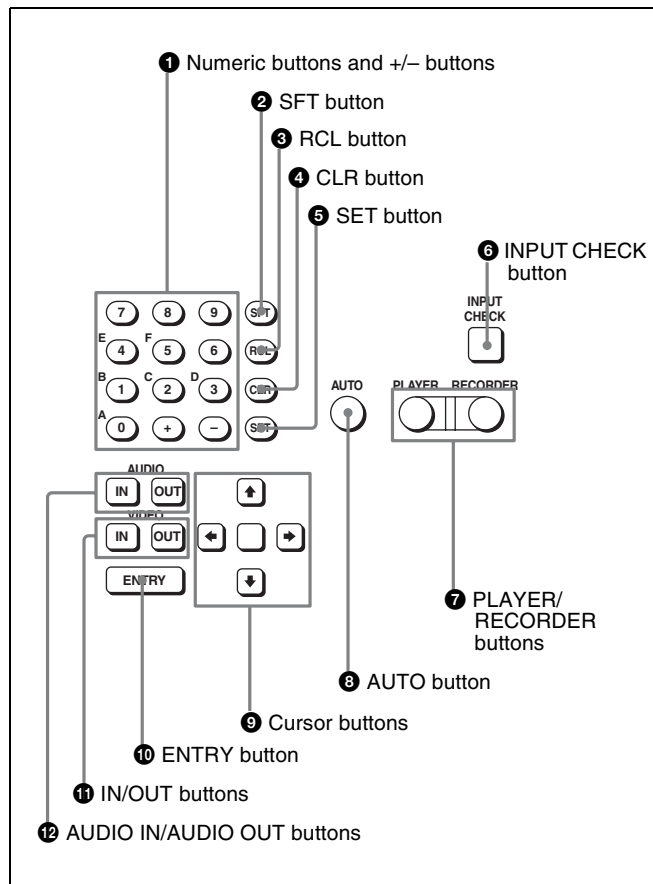

1 Numeric buttons and +/- buttons

Press to input time data or edit points data at the cursor position in menu display. Press buttons 0 to 5 while holding down the SFT button to input hexadecimal A to F for user bits. Use the +/- buttons to increase or decrease settings.

2 SFT (shift) button

Press buttons 0 to 5 while holding down this button to input hexadecimal A to F for user bits.

Use also in combination with other buttons to perform other operations.

3 RCL (recall) button

Press to recall the previous setting, etc.

4 CLR (clear) button

Press to clear input data.

5 SET button

Press to finalize input data.

6 INPUT CHECK button

While you hold down this button, the input signal is output from the monitor output connector, so that you can monitor the input video and audio.

When the LTC/VITC time code is shown on the display, you can check the time code generator.

7 PLAYER/RECORDER buttons

Select which VTR is to be controlled by this VTR's control panel during editing when this VTR is used as a recorder and an external VTR is connected to the REMOTE 1-IN(9P) or REMOTE 1-I/O(9P) connector as a player.

PLAYER: The tape transport buttons and editing operation buttons on the control panel control the external player VTR.

RECORDER: The tape transport buttons and editing operation buttons on the control panel control the recorder VTR (this VTR).

The PLAYER/RECORDER buttons have no effect when using this VTR alone.

8 AUTO button

When this button is pressed, it lights up and auto edit mode is activated.

9 Cursor buttons

Use to move the cursor (shown in reverse video) on the display. Also use to change menu settings.

10 ENTRY button

Press to enter an edit or cue point.

While holding down this button, press either the AUDIO IN or AUDIO OUT button, or the IN or OUT button.

11 IN/OUT buttons

To set a IN or OUT point during editing, press either of these buttons while holding down the ENTRY button.

12 AUDIO IN/AUDIO OUT buttons

To set an AUDIO IN or AUDIO OUT point during insert editing, press either of these buttons while holding down the ENTRY button.

3 Tape transport control section

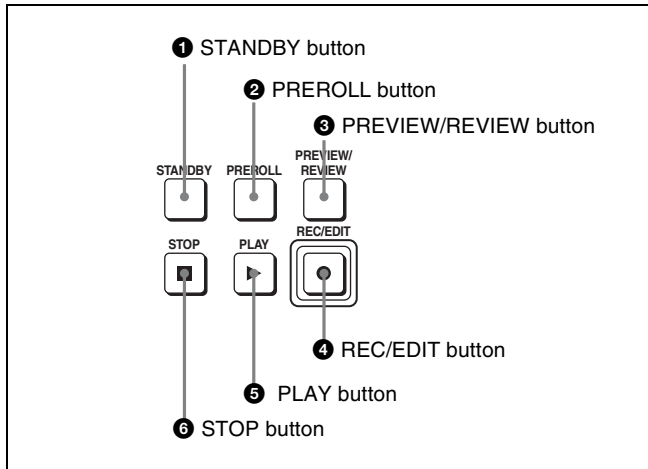

1 STANDBY button

Press this button in other than standby mode to make it light up and place the VTR in standby mode. The head drum rotates in standby mode, thereby shortening the time required for the tape to start.

Press this button while in standby mode to turn the button off and exit from standby mode. The head drum stops rotating and the tape tension is released. If the VTR remains in standby mode for more than eight minutes (factory setting), standby mode is automatically canceled in order to safeguard the tape.

2 PREROLL button

Press to run the tape to the preroll point (a position factory set to five seconds before the IN point).

Press this button while holding down the IN, OUT, AUDIO IN or AUDIO OUT button to cue up the tape at the corresponding edit point.

For details on changing the preroll time, see “4-2-6 Setting the Preroll Time (PREROLL TIME)” on page 53.

3 PREVIEW/REVIEW button

After the edit points are set, press this button to preview, on the monitor connected to the recorder, the effect of the edit before it is performed. In this operation, the tape runs, but no editing is carried out.

If you press this button after carrying out an edit, the results of the edit are played back on the monitor connected to the recorder.

4 REC/EDIT (recording/edit) button

Press this button while holding down the PLAY button to start recording.

If you press this button in play mode, manual editing begins. After setting edit points, if you press this button while the AUTO button is lit, automatic editing is performed.

5 PLAY button

Press to start playback.

Press this button while holding down the REC/EDIT button to start recording.

Pressing this button during recording or manual editing changes the VTR to playback mode.

6 STOP button

Press this button to stop recording or playback.

When you insert the cassette, the VTR automatically enters STBY OFF mode.

The STOP button flashes in the following cases.

- The [F2] (SERVO REF) button in the PF1 menu is set to “input” but there is no video input signal.
- The [F2] (SERVO REF) button in the PF1 menu is set to “ext” but there is no external reference video signal.
- The input signal is out of synchronization with the external reference video signal.

You can change the setting of the VTR SETUP menu item 102 “REFERENCE SYSTEM ALARM” so that the STOP button will not flash in these cases.

4 Display section

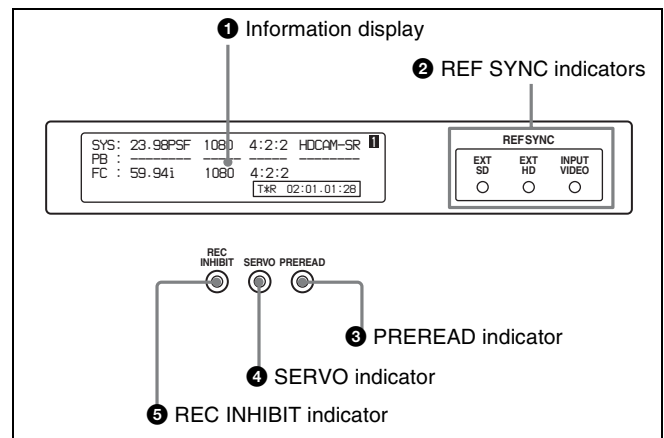

1 Information display

The information display shows a number of different pages. To change the page displayed, with no other items selected in the menu display (HOME, TC, VIDEO, AUDIO, PF1, and PF2), turn the MULTI CONTROL knob while holding it down.

The currently selected page number also appears at the upper right of the information display.

Page 1: System status

- SYS:** Shows the recording system information (signal standard and tape format).
- PB:** Shows the information recorded on the tape (signal standard and tape format) while being played back.
- FC:** Shows the converted signal standard when an HKS-5001 board is installed.
- TC:** Shows the LTC/VITC and DF/NDF settings, or the time code sent to the external monitor.

Page 2: System status

- ACTIVE LINE:** Shows the status of 1080/1035 conversion active line.
- 1080→1080
- 1080→1035(CROP)
- 1080→1035(CONV)
- 1035→1035
- 1035→1080(PANEL)
- 1035→1080(CONV): Shows the current conversion status.
- : Cannot be converted.
- OFF: No conversion done.
- DOWN CONV. OUTPUT:** Shows the output status of the down converter.
- ACTIVE: Output.
- MUTING: No output.
- EOS:** Appears at the location of the time code for the valid end of the previous recording.

Page 3: Phase (OUTPUT)

- HD SDI OUTPUT ADV.:** Shows the phase of the main line HD SDI output.
- OFF: In phase with reference.
- 90H: 90H (HD) advanced with respect to reference.
- DOWN CONV. OUTPUT ADV.:** Shows the phase of the down converter output.
- OFF: In phase with reference.
- 2H: 2H (SD) advanced with respect to reference.

Page 4: Phase (AUDIO)

- AUDIO PB OUTPUT ADV.:** Shows the phase of the audio output signal.
- OFF: Output in phase with the video output signal.
- 1Frame: Output one frame advanced with respect to the video output signal.
- AUDIO INPUT DELAY:** Shows the recording phase of the audio input signal.
- OFF: Recorded in phase with the video output signal.
- +1Frame: Recorded one frame delayed with respect to the video input signal.
- AES/EBU & ANA OUTPUT:** Shows the phase of the AES/EBU and ANALOG AUDIO outputs.
- REF: Output in phase with reference.
- FC: In phase with the FC output.
- 90H(HD): 90H (HD) advanced with respect to reference.
- 2H(SD): 2H (SD) advanced with respect to reference.

Page 5: Phase (TC)

- TC INPUT DELAY:** Shows the recording phase of the input time code.
- OFF: Recorded in phase with the input video signal.
- +1Frame: Recorded one frame delayed with respect to the input video signal.
- LTC OUTPUT:** Shows the phase of the output LTC.
- LINE: Output in phase with the main line HD SDI output.
- FC: Output in phase with the FC output.

Page 6: Meta Data

The display changes depending on the tape format in use.

- **HDCAM-SR**
 - META DATA LINE(REC):** Shows the status of the three lines for metadata recording on this unit.
 - META DATA LINE(OUT):** Shows the status of the three lines of main HD SDI output into which metadata is multiplexed.
 - META DATA LINE(FC):** Shows the status of the three lines of output from the optional HKS-5001 format converter board into which metadata is multiplexed.
 - META DATA LINE(SD):** Shows the status of the three lines of SD SDI output into which metadata is multiplexed.
- **HDCAM**
 - Displays L1/L2/DID/SDID. This combination is counted as 1 packet. Up to 3 packets can be recorded. On the SRW-5500, the system settings related to recording are shown on the left. If data is detected in the input signal, the L1/L2 values are highlighted. The right side shows playback values detected on the tape.

Note

The ACTIVE LINE setting displayed on page 2 can be made in the SYSTEM screen. The phase settings displayed on pages 3 to 5 and the settings relating to META DATA recording displayed on page 6 can be made in the PHASE SET/META DATA menu under the ALT+OTHERS CHECK menu in the MAINTENANCE menu.

For details, refer to the Installation Manual.

② REF SYNC (reference signal) indicators

- These indicate the signal selected as the reference signal. If there is no reference signal input to the selected connector, the STOP button flashes.
- EXT SD:** Lights when “extern SD” is selected by the VTR SETUP menu item 006 “EXTERNAL REFERENCE select”.
- EXT HD:** Lights when “extern HD” is selected by the VTR SETUP menu item 006 “EXTERNAL REFERENCE select”.
- INPUT VIDEO:** Lights when “INPUT” is selected by the VTR SETUP menu item 005 “SERVO/AV REFERENCE select”.

3 PREREAD indicator

Lights up during preread mode.

For more information about PREREAD, see “6-2-2 Animation Editing” on page 128.

4 SERVO indicator

Lights up when the drum servo and capstan servo are locked.

5 REC INHIBIT indicator

Only when this indicator is not lit, you can make settings for assemble/insert editing mode, and carry out recording and playback operations.

The status of this indicator depends on the setting of the [F2] (REC INH) button in the HOME menu and the state of the record-protect plug on the cassette.

Setting of the [F2] (REC INH) button in the HOME menu	State of the record-protect plug on the cassette	REC INHIBIT indicator
all	Recording disabled	Lit/flashing ^{a)}
	Recording allowed	Lit
crash REC, video/CTL, audio/CTL	Recording disabled	Lit/flashing ^{a)}
	Recording allowed	Unlit
off	Recording disabled	Lit/flashing ^{a)}
	Recording allowed	Unlit ^{a)}

a) Toggling between lit/flashing settings is possible using the VTR SETUP menu item 104 “REC INHIBIT LAMP FLASHING”.

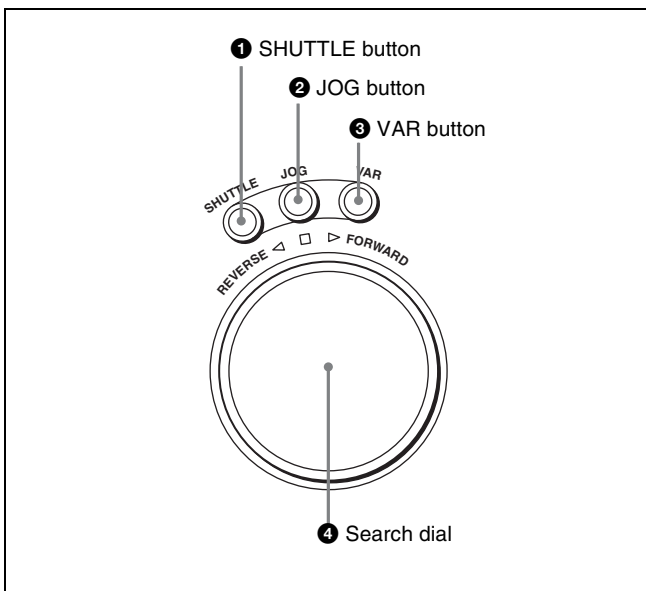
5 Search control section**1 SHUTTLE button**

Press to enter shuttle mode. In this mode, the button lights and playback at the speed corresponding to the angle of rotation of the search dial is possible. The playback speed

range depends on the frame frequency of the unit. In this mode, the search dial clicks at the positions for 0 (still picture) and ± 10 times normal playback speed (HDCAM/Digital Betacam) or ± 8 times normal playback speed (HDCAM-SR).

Frame frequency	Playback speed
23.98/24 Hz	Ranging from ± 50
25 Hz	Ranging from ± 48
29.97/30 Hz	Ranging from ± 40

2 JOG button

Press to select jog mode. In this mode, the button lights up and playback is possible at -1 to $+1$ times normal speed, ± 2 times normal speed (HDCAM/HDCAM-SR), or ± 3 times normal speed (Digital Betacam) (determined by the setting in the VTR SETUP menu item 107 “JOG DIAL RESPONSE”). In this mode, the search dial does not click.

3 VAR (variable) button

Press to select variable speed playback mode for noiseless playback in the range from -1 to $+2$ times normal speed (HDCAM/HDCAM-SR) or -1 to $+3$ times normal speed (Digital Betacam). Playback exceeding this speed range is not possible. The search dial clicks at the positions for still-picture and normal playback speed.

4 Search dial

Rotate to search for edit points. Rotate the dial clockwise for forward playback (the \blacktriangleright indicator lights up) or counterclockwise for reverse playback (the \blacktriangleleft indicator lights up). The \blacksquare indicator lights up while the VTR is in stop mode.

Shuttle mode: The playback speed corresponds to the angle of rotation of the search dial. The playback speed range depends on the frame frequency of the unit. (See item 1 SHUTTLE button.) The dial clicks at the positions for 0 (still picture) and ± 10 times normal playback speed (HDCAM/Digital Betacam) or ± 8 times normal playback speed (HDCAM-SR).

Jog mode: The playback speed corresponds to the rotational speed of the dial (-1 to $+1$ times normal speed, ± 2 times normal speed (HDCAM/HDCAM-SR), or ± 3 times normal speed (Digital Betacam)) depending on the setting of the VTR SETUP menu item 107 “JOG DIAL RESPONSE”). The dial does not click.

Variable speed playback mode: Noiseless playback is possible in the range from -1 to $+2$ times normal speed (HDCAM/HDCAM-SR) or -1 to $+3$ times normal speed (Digital Betacam). The speed settings can be changed using the menu. The dial clicks at the positions for still-picture and normal playback speed.

Capstan override mode: Rotating the dial while holding down the PLAY button changes the playback speed by up to $\pm 15\%$.

2-1-3 System Set-Up Panel

Lift the lower control panel up to its horizontal position to access the system set-up panel.

For details of opening and closing the control panel, refer to the Maintenance Manual.

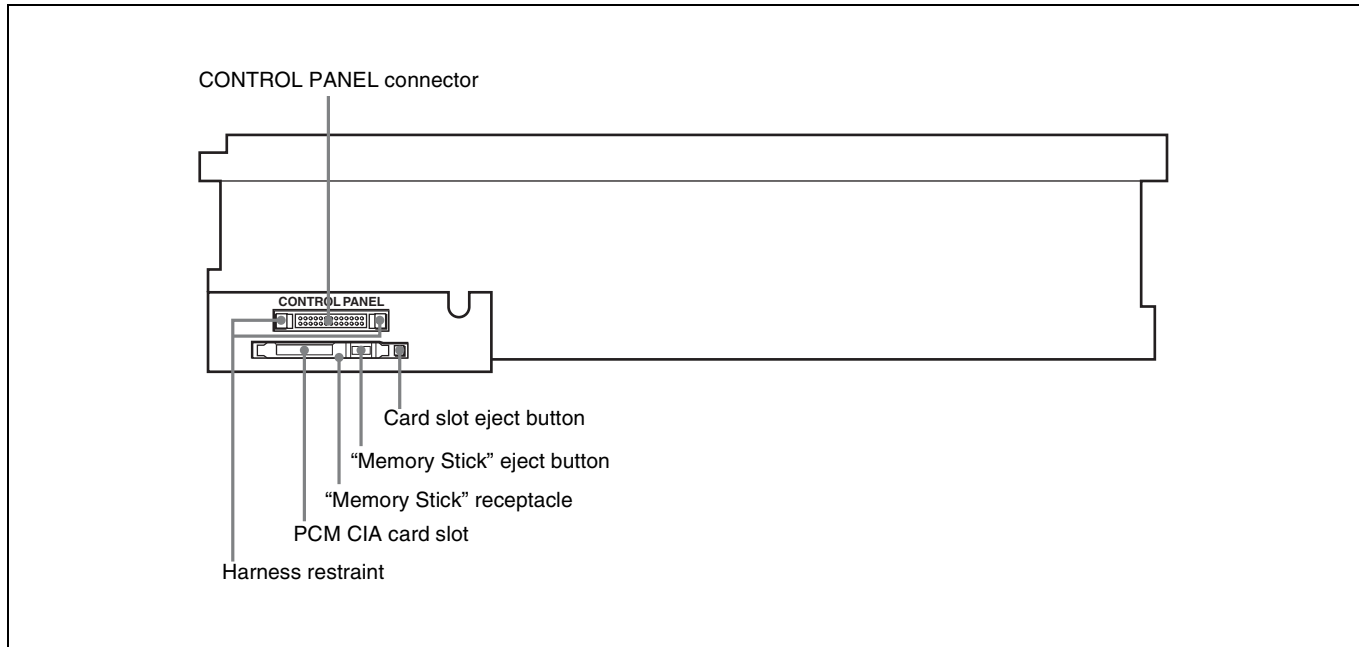

For details, see "3-4 Using a "Memory Stick"" on page 36.



2-2 Connector Panel

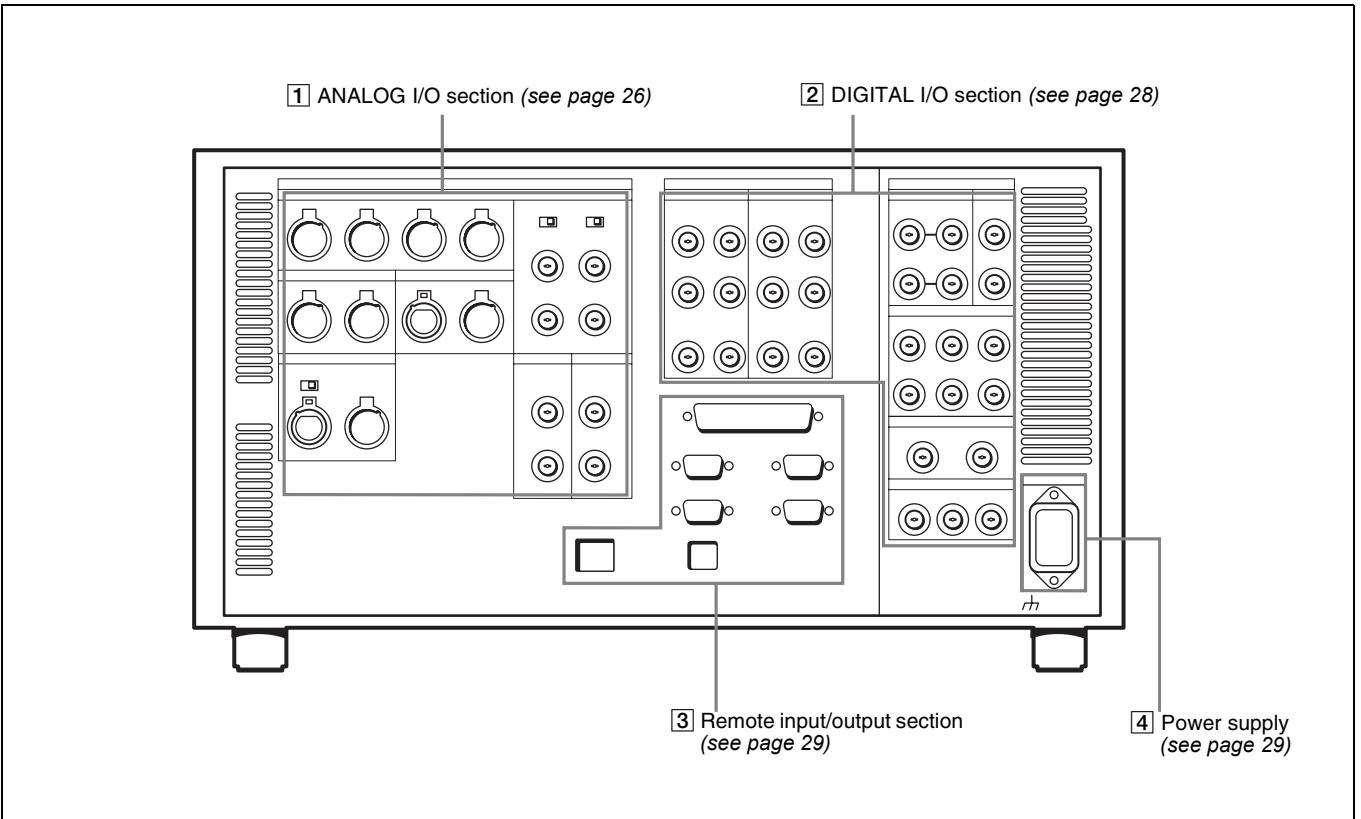

1 ANALOG I/O (input/output) section

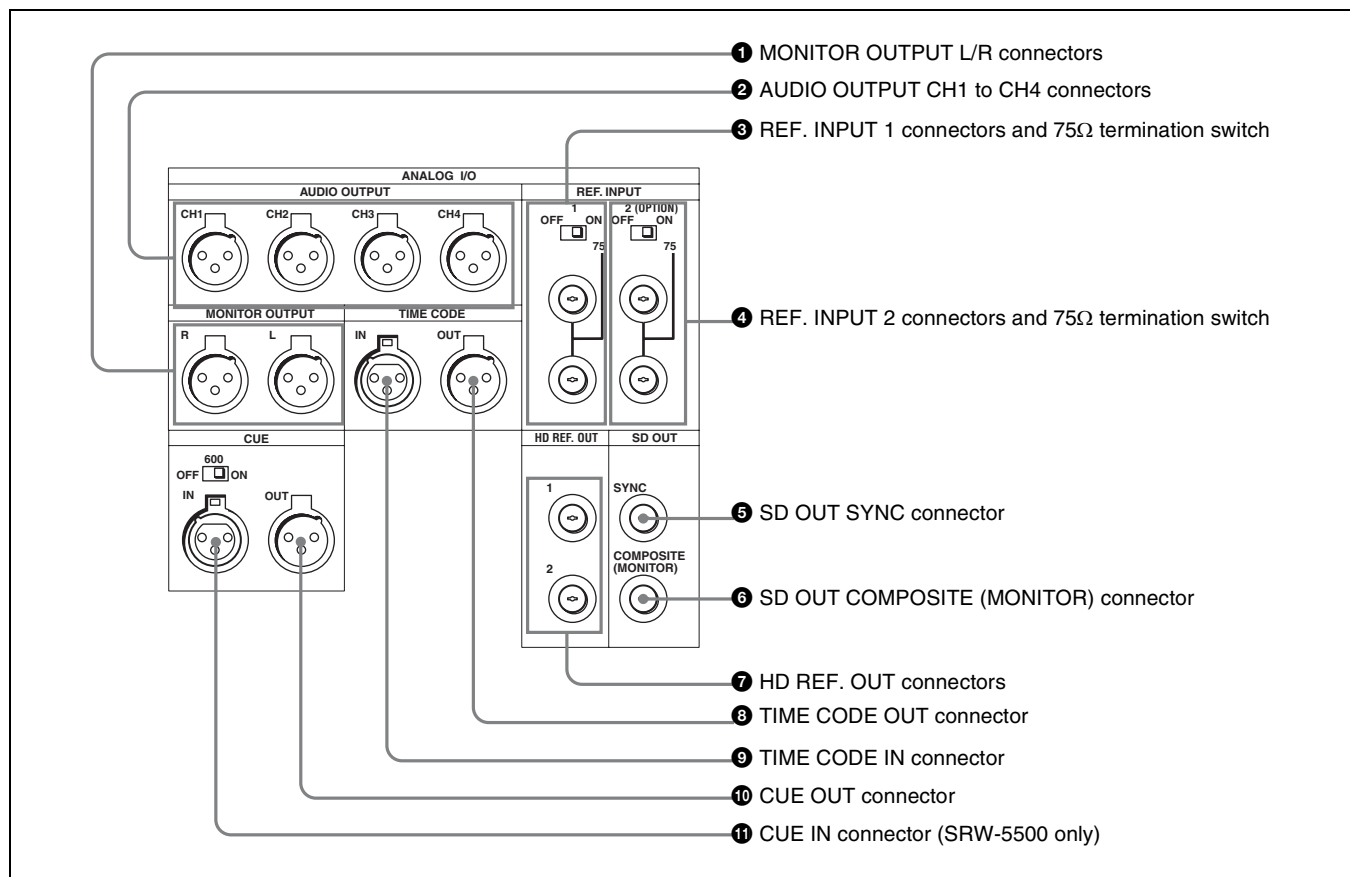

1 MONITOR OUTPUT L/R connectors (XLR-3-31, male)

These output the audio signals for monitoring L and R channels. To select the signals to output, use the MONITOR R and MONITOR L buttons on the lower control panel.

For details, see “5-1-2 Selecting Audio Signals” on page 104.

2 AUDIO OUTPUT CH1 to CH4 connectors (XLR-3-31, male)

These output up to four analog audio signal lines (channels 1 to 4).

3 REF. INPUT 1 connectors (BNC) and 75Ω termination switch

Input a reference video signal of the selected field frequency. Select HD or SD with the VTR SETUP menu item 006 “EXTERNAL REFERENCE select”. When HD is selected, input a tri-level SYNC signal. When SD is selected, input a video signal with chroma burst (VBS) or a monochrome video signal (VS).

A loop-through connection is possible. Set the 75Ω termination switch to OFF if you are using a loop-through connection and set it to ON if you are not using a loop-through connection.

4 REF. INPUT 2 connectors (BNC) and 75Ω termination switch

Input a reference video signal of the field frequency selected for the format converter output. Select HD or SD with the VTR SETUP menu item A08 “FC REFERENCE select”. When HD is selected, input a tri-level SYNC signal for external synchronization. When SD is selected, input a video signal with chroma burst (VBS) or a monochrome video signal (VS). A loop-through connection is possible. Set the 75Ω termination switch to OFF if you are using a loop-through connection and set it to ON if you are not using a loop-through connection.

5 SD OUT SYNC connector (BNC)

This outputs an NTSC or PAL signal for external synchronization.

Note

The output phase is the same as that of the composite signal output from the SD OUT COMPOSITE (MONITOR) connector.

Because the output phase changes with the operation mode of the VTR, use this for synchronization with the video monitor.

6 SD OUT COMPOSITE (MONITOR) connector (BNC)

Outputs an analog composite signal for a video monitor. When the ALT/[F6] (CHARA SUPER) setting in the TC menu is on, character signals such as time codes are superimposed on the output.

7 HD REF. OUT connectors (BNC)

Output an HD tri-level sync signal during tape playback.

8 TIME CODE OUT connector (XLR 3-31, male)

Outputs the following time codes according to the VTR operation mode.

In playback mode: Playback time code

In recording mode: Time code generated by the internal time code generator, or time code input to the TIME CODE IN connector.

To select the output signal, use the VTR SETUP menu item 613 “TC OUTPUT SIGNAL IN REGENE MODE.”

Setting	Description
off tape	In playback mode, playback time code signal is output. In recording mode, TCG time code signal is output.
regene	Only when the servo is locked in playback mode, playback time code signal is regenerated and output. In all other cases, output is the same as for the “off tape” setting.
through	The time code signal from the TIME CODE IN connector is output as it is. (Used for cascade connections.) <i>(For more information about cascade connections, see “3-1-3 Cascade Connection” on page 32.)</i>

9 TIME CODE IN connector (XLR 3-32, female)

Accepts external time code for recording to tape. Connect to the time code output connector of the external equipment.

10 CUE OUT (cue output) connector (XLR 3-31, male)

Outputs cue track audio during HDCAM or Digital Betacam playback.

Note

There is no cue track on an HDCAM-SR tape, and therefore no output.

11 CUE IN (cue input) connector (XLR 3-31, female) (SRW-5500 only)

Enabled only during HDCAM format recording.

2 DIGITAL I/O (input/output) section

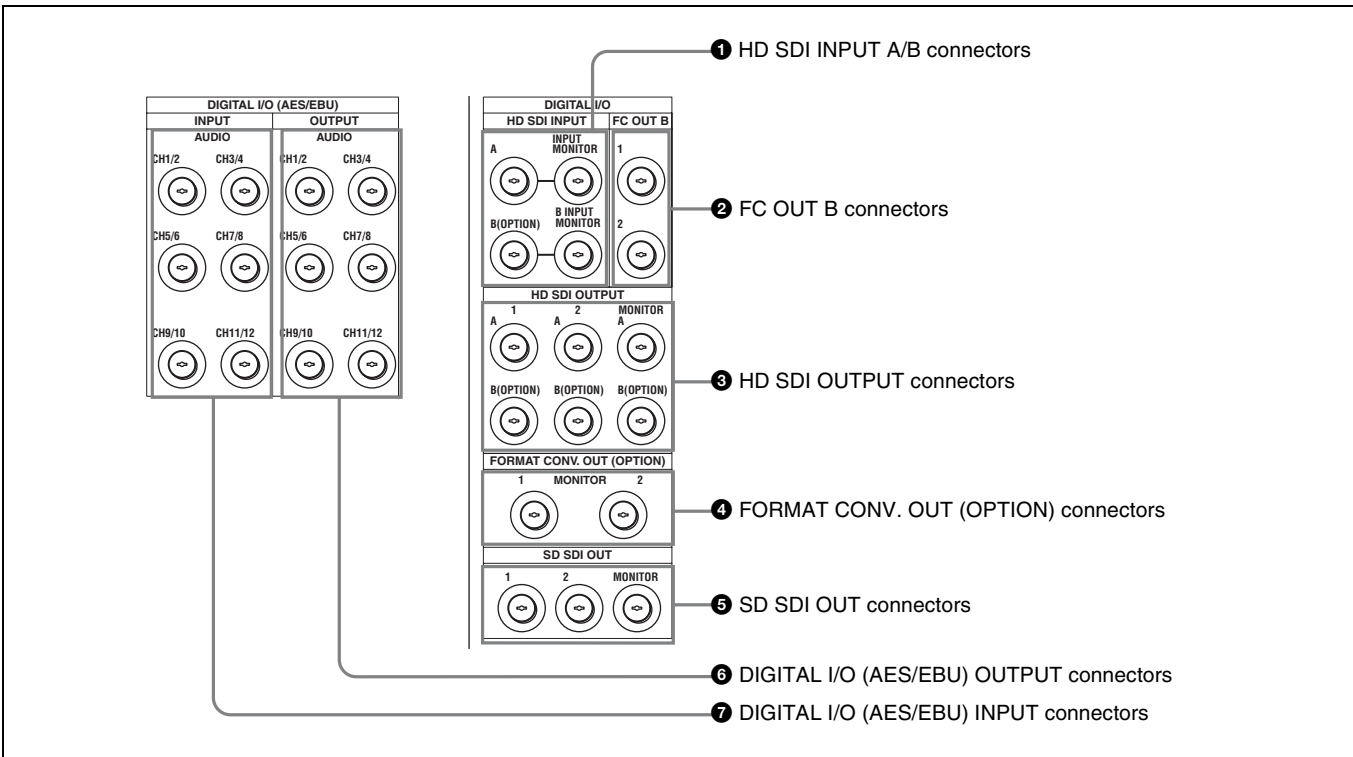

1 HD SDI (SDI video/audio) INPUT A/B connectors (BNC)

These accept SDI video/audio signals.

Note

The INPUT MONITOR connectors are for use with an input monitor and does not follow the standards for output.

2 FC OUT B (FORMAT CONV. OUTPUT B (OPTION)) connectors (BNC)

These are only effective when the optional HKS-5001 format converter board is installed. When the output format is selected as 4:4:4, LINK B is output, and when the output format is selected as 4:2:2 it is not output.

3 HD SDI (SDI video/audio) OUTPUT connectors (BNC)

These output three sets of SDI video/audio signals. When the ALT/[F6] (CHARA SUPER) buttons are set to ON in the TC menu, time data or other text data is superimposed on the signal output from the MONITOR A connector.

4 FORMAT CONV. OUT (OPTION) connectors (BNC)

These output two sets of format-converted video/audio signals.

When the ALT/[F5] (PD CHARA) buttons are set to ON in the TC menu, the output has time data or other text superimposed on the signal.

Note

This is only valid when the optional HKS-5001 format converter board is installed. When the output format is selected as 4:4:4, LINK A is output.

5 SD SDI (1/2/monitor) OUT connectors (BNC)

These output three sets of video/audio signals. When the ALT/[F6] (CHARA SUPER) buttons are set to ON in the TC menu, time data or other text data is superimposed on the output from the MONITOR OUTPUT L/R connector.

6 DIGITAL I/O (AES/EBU) OUTPUT connectors (BNC)

These output digital signals in AES/EBU format for channels 1 to 12.

7 DIGITAL I/O (AES/EBU) INPUT connectors (BNC)

These accept digital signals in AES/EBU format for channels 1 to 12.

3 Remote input/output section

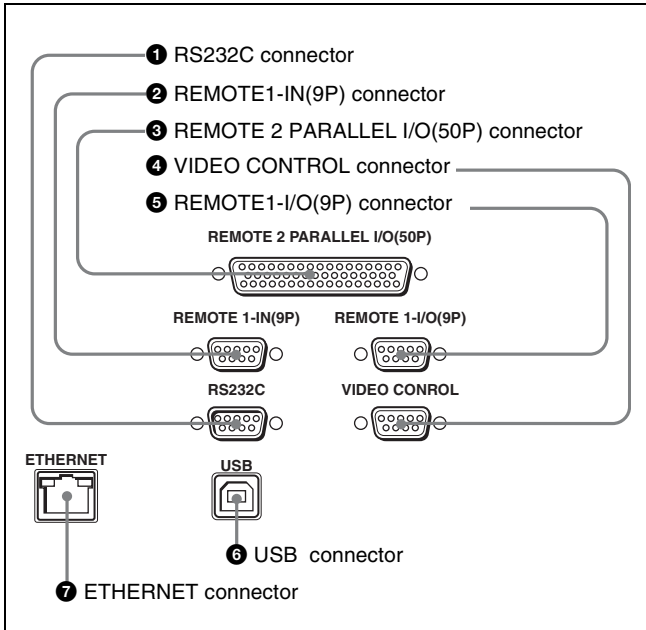

1 RS232C connector (RS-232C serial interface) (D-sub 9-pin)

This is used for manufacturing and services.

2 REMOTE 1-IN(9P) connector (D-sub 9-pin, female)

Use this, with the supplied 9-pin remote control cable, to connect the unit to another SRW-5000/5500 unit or another HD VTR unit to carry out editing with a BVE-series editor BVE-900/910/2000/9000/9100.

3 REMOTE 2 PARALLEL I/O(50P) connector (D-sub 50-pin, female)

Inputs an external remote control signal.

For details, refer to the Maintenance Manual Volume 1.

4 VIDEO CONTROL (Digital Video Processor Control) connector (D-sub 9-pin, female)

Connects to the optional HKDV-900 HD Digital Video Controller to enable remote control of the internal digital video processor. Turn off the power before connecting the remote controller.

5 REMOTE 1-I/O(9P) connector (D-sub 9-pin, female)

Use this, with the supplied 9-pin remote control cable, to connect the unit to another SRW-5000/5500 unit or another HD VTR unit to carry out editing with a BVE-series editor BVE-900/910/2000/9000/9100.

6 USB connector

This is used for manufacturing and services.

7 ETHERNET connector

Used for monitoring the VTR by SNMP, or for setting or changing VTR settings by HTTP.

CAUTION

For safety, do not connect the connector for peripheral device wiring that might have excessive voltage to this port. Follow the instructions for this port.

ATTENTION

Par mesure de sécurité, ne raccordez pas le connecteur pour le câblage de périphériques pouvant avoir une tension excessive à ce port. Suivez les instructions pour ce port.

VORSICHT

Aus Sicherheitsgründen nicht mit einem Peripheriegerät-Anschluss verbinden, der zu starke Spannung für diese Buchse haben könnte. Folgen Sie den Anweisungen für diese Buchse.

4 Power supply

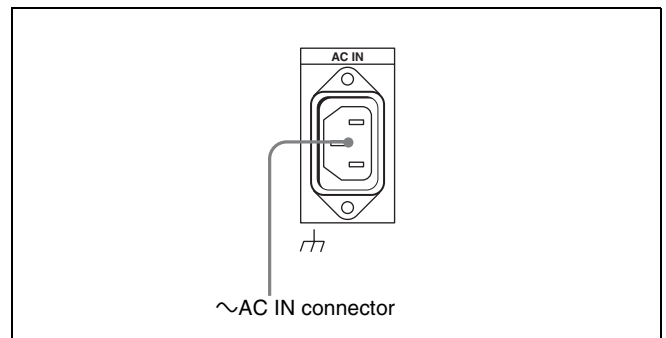

~AC IN connector

Connects to an AC outlet using an appropriate power cord.

3-1 Connecting External Equipment

3-1-1 Making HD Digital Connections

This example shows the connections when using an HDW-F500 as player and an SRW-5000/5500 as recorder, in 59.94i or 60i mode.

See “Specifications” in the Appendix (page 132) for recommended XLR/BNC and P/S converters.

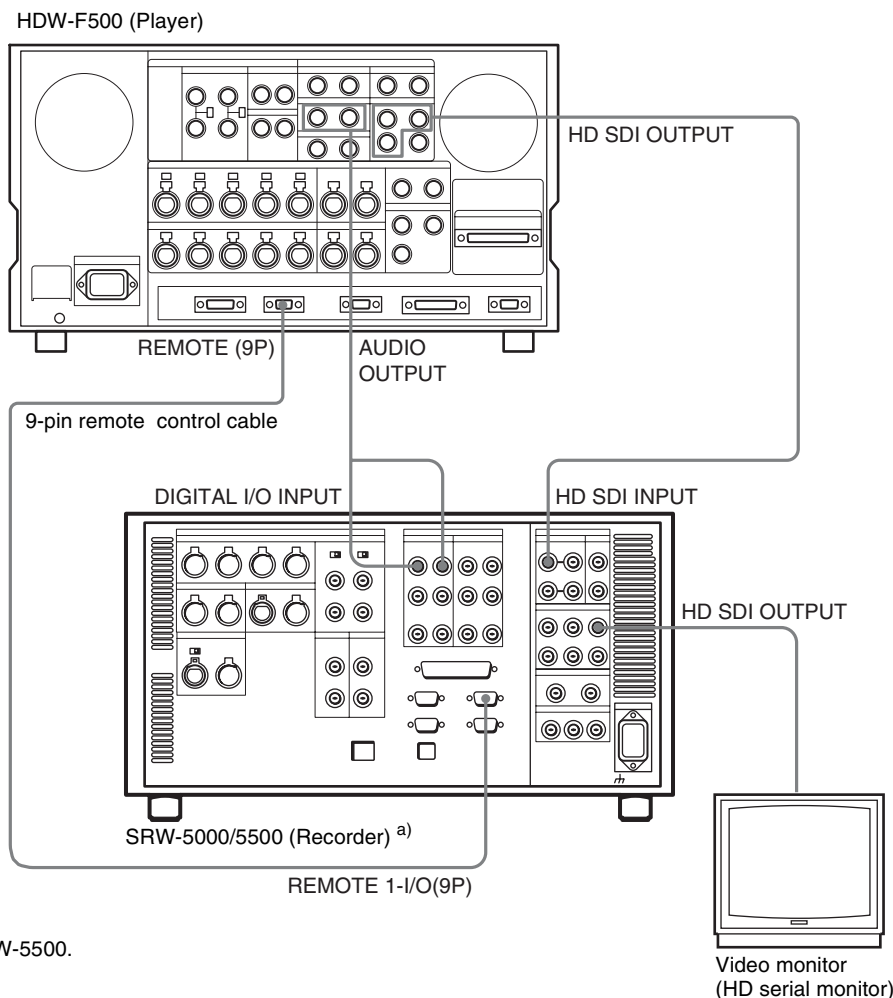

a) The figure shows the SRW-5500.

3-1-2 Making NTSC/PAL Digital Connections

This example shows how to connect two VTRs, an SRW-5000/5500 as the player and a DVW-500 D-1 Component Digital VTR as the recorder.

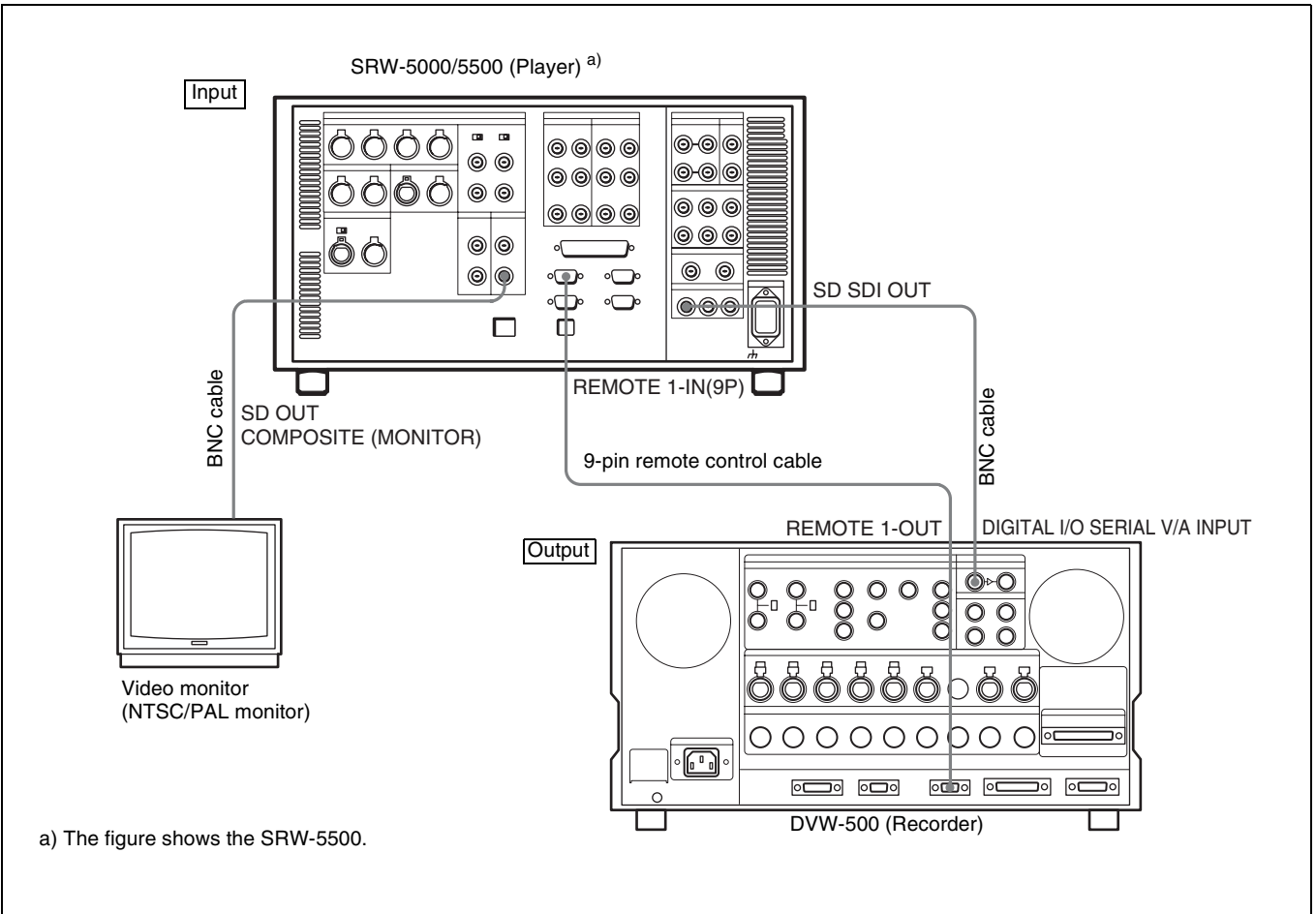

Note

For color frame editing using the SRW-5000/5500 as the player and an NTSC/PAL digital device as the recorder, set the VTR SETUP menu item 005 “SERVO/AV REFERENCE select” to “external” and set the menu item 006 “EXTERNAL REFERENCE select” to “extern SD”.

3-1-3 Cascade Connection

This example shows how to connect multiple SRW-5000/5500 VTRs together for simultaneous recording.

Note

On the recording VTRs, set the VTR SETUP menu item 613 “TC OUTPUT SIGNAL IN REGENE MODE” to “through”.

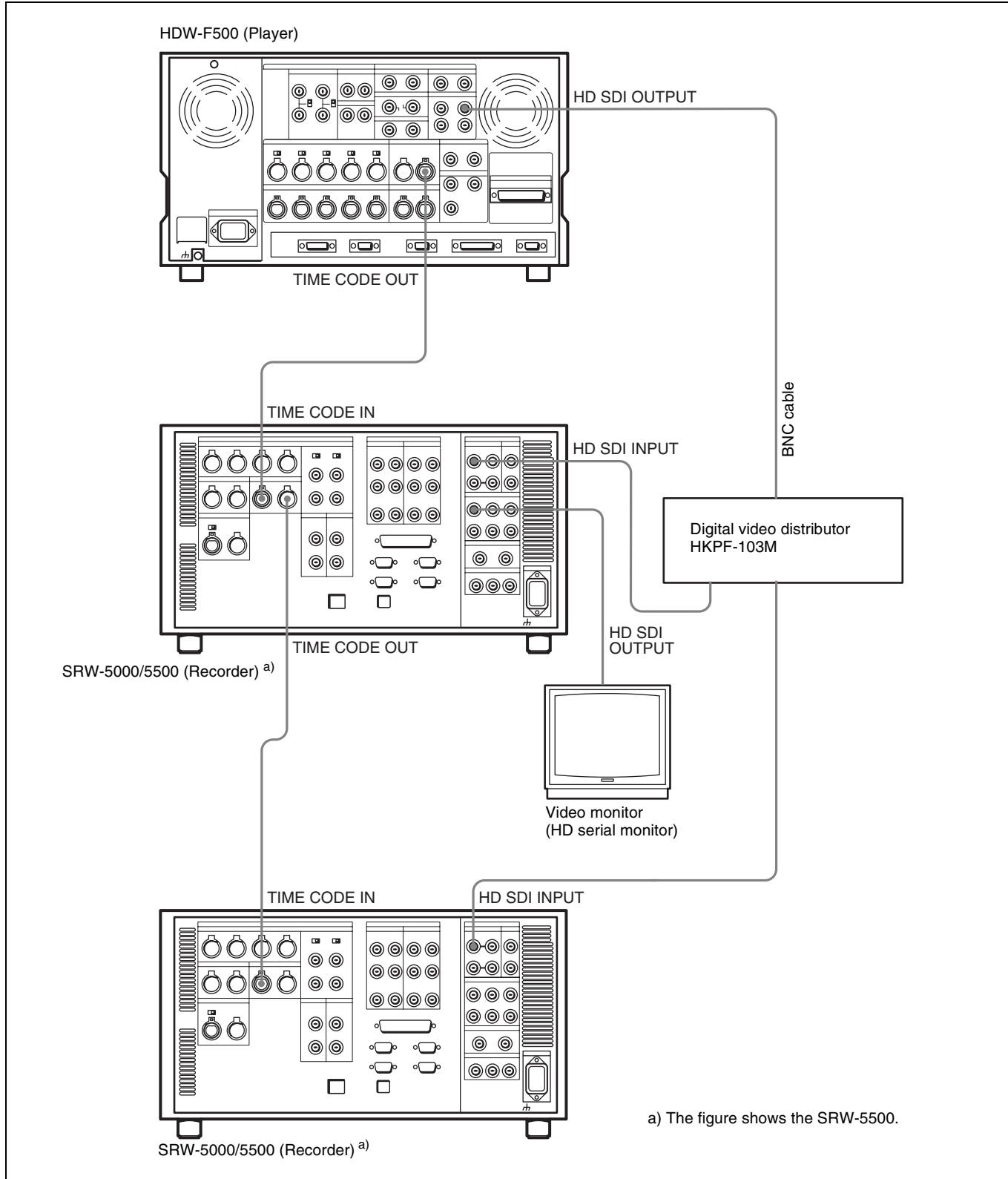

3-2 Reference Signals

This section describes how reference signals for the video output are selected.

3-2-1 Reference Signals for Output Video

Depending on the operating condition, VTR SETUP menu settings, the input signal, and the video output signal from the VTR can be synchronized as follows.

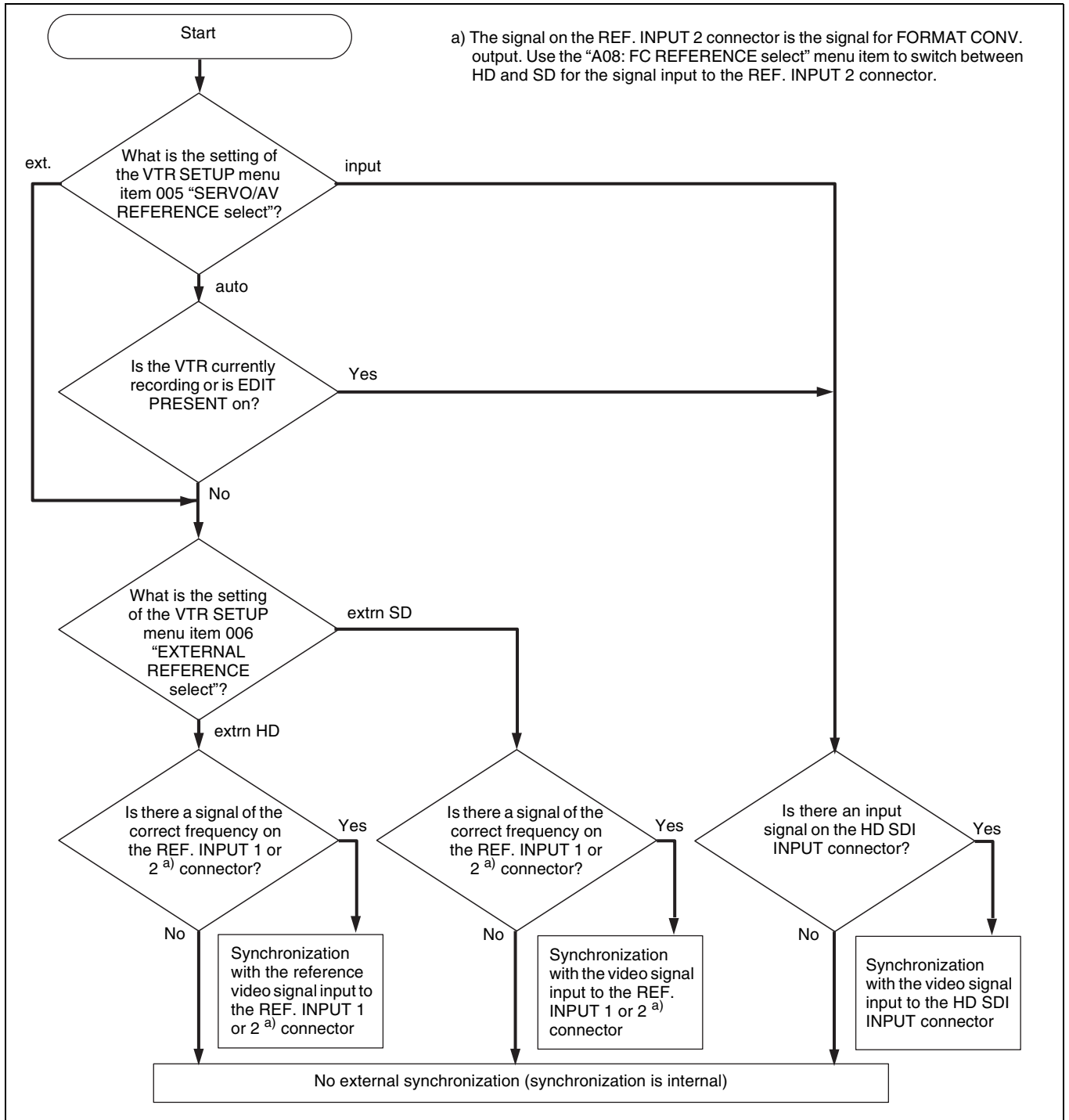

3-2-2 Reference Signal Connections

Make the reference signal connections as follows, according to your recording or playback requirements.

Reference signal connections

For recording signals from a switcher or signal generator

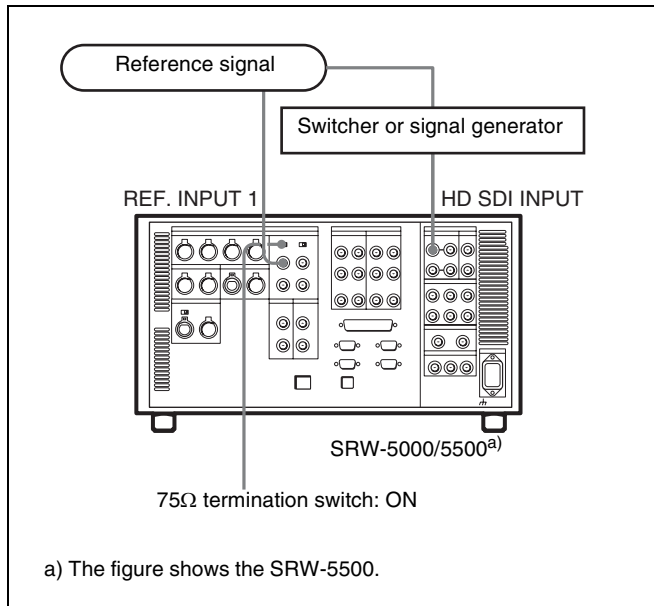

For recording signals from a HD VTR

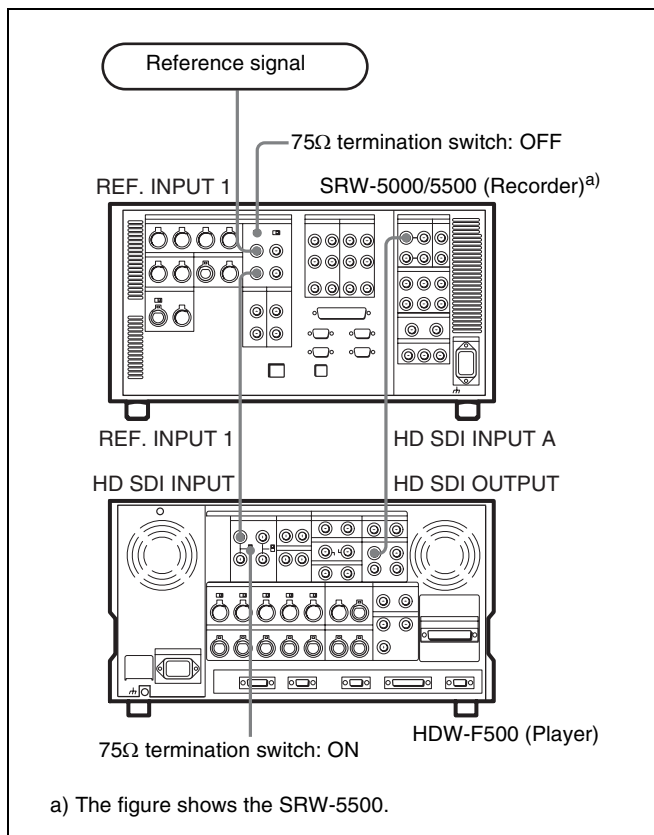

For playback

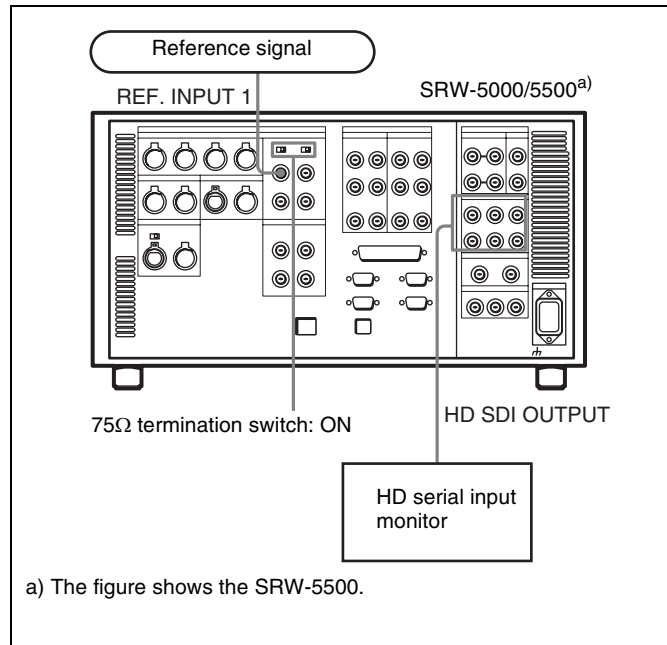

Note

The following signals can be used as a reference signal.

- HD trilevel SYNC signal of an appropriate field frequency for external synchronization
- Black burst signal of 525/59.94 Hz
- Black burst signal of 625/50 Hz

Input the signal of the appropriate field frequency for your system.

Sync signals in 720p mode

Synchronize to an external sync signal when you want to record or play back 720p signals on this unit (including editing).

- When the 720/59.94p system is selected:
You can select the following reference signals from menu item 006 “EXTERNAL REFERENCE select”.
extrn HD: 1080/59.94i tri-level SYNC signal
extrn SD: 525 black burst signal
- When the 720/50p system is selected:
You can select the following reference signals from menu item 006 “EXTERNAL REFERENCE select”.
extrn HD: 1080/50i tri-level SYNC signal
extrn SD: 625 black burst signal

When you have directly connected the input and output connectors of two SRW-5000/5500 units, you can also perform dubbing with the VTR SETUP menu item 005 being set to “input”.

3-3 Handling Cassettes

3-3-1 Recommended Cassettes

For recording and playback:

Use 1/2 inch HDCAM-SR cassettes.

The maximum recording time is as shown in the following table.

System frequency HDCAM SR-cassette	29.97/30 Hz	25 Hz	23.98/24 Hz
S-size cassette	40 minutes	48 minutes	50 minutes
L-size cassette	124 minutes	149 minutes	155 minutes

For playback only:

Use 1/2 inch HDCAM or Digital Betacam cassettes.

The maximum playback time is as shown in the following table.

System frequency HDCAM cassette	29.97/30 Hz	25 Hz	23.98/24 Hz
S-size cassette	40 minutes	48 minutes	50 minutes
L-size cassette	124 minutes	149 minutes	155 minutes

Note

HDCAM cassettes are for playback only on the SRW-5000. They can be played back and recorded on the SRW-5500.

System frequency Digital Betacam cassette	29.97 Hz	25 Hz
S-size cassette	40 minutes	40 minutes
L-size cassette	124 minutes	124 minutes

Note

Playing back a digital Betacam cassette requires the Digital Betacam Option (HKSR-5002).

Storage of cassettes

Store your cassettes at room temperature and normal humidity.

3-3-2 Inserting and Ejecting Cassettes

Always turn on the VTR before inserting or ejecting cassettes.

Inserting a cassette

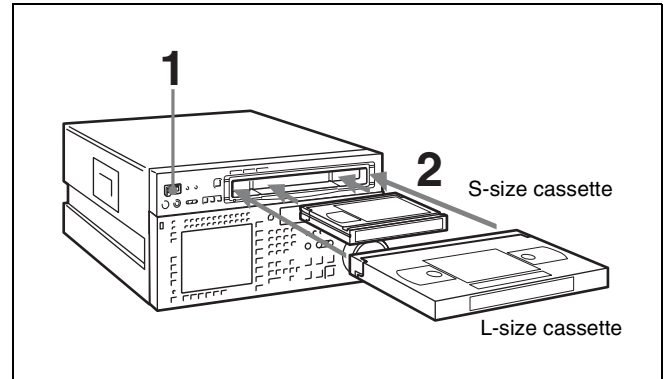

- 1 Turn the POWER switch to ON.
- 2 Before inserting a cassette, check the following points:
 - There is no slack in the tape.
 - An error message does not appear in the menu display.
 - The window of the cassette is facing up.

If there is any slack in the tape, see “Removing slack in the tape” on page 35.

When inserting an S-size cassette, make sure it is aligned with the marks on the cassette insertion slot.

The cassette is loaded automatically, and the tape is wound around the drum.

Removing slack in the tape

Press one of the reels in slightly, then carefully rotate it in the direction of the arrow until it stops.

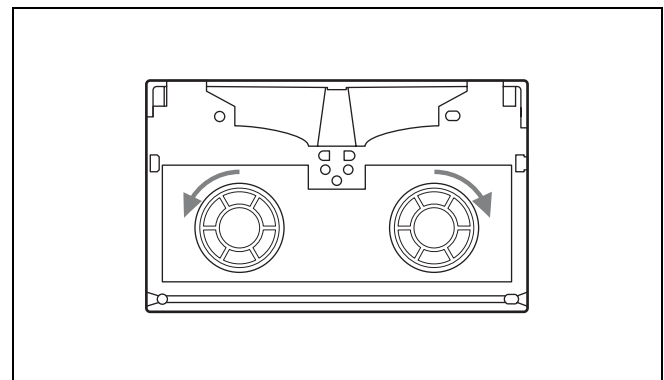

Preventing double cassette inserting

When a cassette is loaded, an orange lock-out bar appears in the cassette insertion slot to prevent users from attempting to load another cassette.

Ejecting the cassette

Press the EJECT button.

The tape is unthreaded and the cassette is automatically ejected. This operation takes a few seconds.

To cancel ejecting a cassette

Press any operation button before the cassette is completely ejected. The cassette is loaded again and the operation corresponding to the button you pressed starts.

3-3-3 Preventing Accidental Erasure

To prevent accidental erasure of material recorded on a tape, push in the record-protect plug.

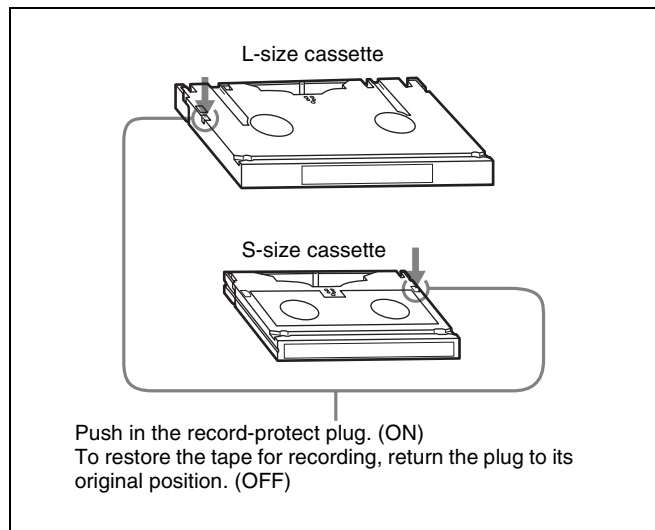

When a cassette with this plug pushed in is inserted into the VTR, the REC INHIBIT indicator on the lower control panel lights up and recording will not start, even if you press the REC/EDIT button.

To restore the tape for recording, return the plug to its original position.

3-4 Using a “Memory Stick”

When a “Memory Stick” is inserted in the VTR, the file data can be stored on the “Memory Stick”, which enables you to share data among VTRs.

Inserting a “Memory Stick”

With the label side up and the connector facing forward, insert the “Memory Stick” into an optional memory card adaptor. Then, with the “Memory Stick” still loaded, insert the memory card adaptor into the memory card slot of the unit.

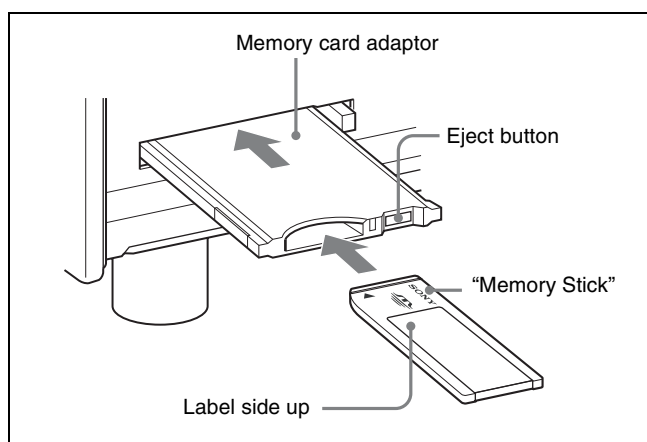

Note

Never insert/remove a “Memory Stick” during access to data.

To remove a “Memory Stick”

Push the eject button on the memory card adaptor, and pull the “Memory Stick” out.

3-4-1 Notes on “Memory Stick”

On “Memory Stick”

“Memory Stick” is a new compact, portable and versatile IC recording medium with a data capacity that exceeds that of a floppy disk. “Memory Stick” is specially designed for exchanging and sharing digital data among “Memory Stick” compatible products. Because it is removable, “Memory Stick” can also be used for external data storage.

Types of “Memory Stick”

There are two types of “Memory Stick”: MagicGate “Memory Stick” that is equipped with the MagicGate copyright protection technology and general “Memory

Stick". Use the general type of "Memory Stick" (8MB, 16MB, 32MB, 64MB, 128MB) with this unit.

On MagicGate

MagicGate is copyright-protection technology that uses encryption technology.

Before using a "Memory Stick"

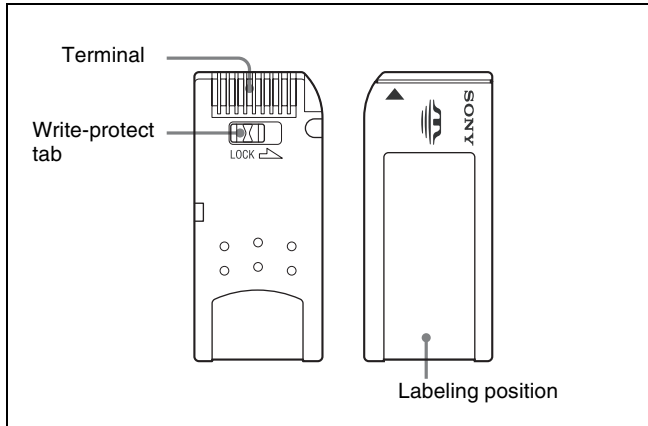



- You cannot record or erase data when the write-protect tab on the "Memory Stick" is set to LOCK.
- We recommend backing up important data.
- Image data may be damaged in the following cases:
 - If you remove the "Memory Stick", or turn the power off when the access lamp is lit or flashing
 - If you use a "Memory Stick" near static electricity or a magnetic field

Notes

- Prevent metallic objects or your finger from coming into contact with the terminal of the connecting section.
- Do not attach any material other than the supplied label to the label space.
- Attach the label at the prescribed labeling position. Make sure the label is attached at the labeling position properly.
- Do not bend, drop, or apply strong shock to a "Memory Stick".
- Do not disassemble or modify a "Memory Stick".
- Do not let the "Memory Stick" get wet.
- Do not use or keep a "Memory Stick" in locations that are:
 - Extremely hot such as in a car parked in the sun
 - Under direct sunlight
 - Very humid or subject to corrosive gases
- When you carry or store a "Memory Stick", keep it in its case.
- The PCMCIA memory card supplied with the HDW-500/F500 and the HDW-2000 series cannot be used with the SRW-5000/5500.

During access to data

While data are being read from or written to the "Memory Stick", do not shake this unit or subject it to shock. Do not turn off the power of the unit or remove the "Memory Stick". This may damage the data.

"Memory Stick" and  are the trademarks of Sony Corporation.
MagicGate "Memory Stick" and  are the trademarks of Sony Corporation.

Note

The MSAC-PC4 Memory Stick PC Card Adaptor is not supplied with the following units.

SRW-5000: Serial No. 12203 and higher

SRW-5500: Serial No. 12810 and higher

Using a "Memory Stick" with these units requires the MSAC-PC4 or equivalent.

4-1 Registering and Storing Menu Settings

The operating conditions of the VTR are set using the menu operation section on the lower control panel. Menu items are divided among eight different menus (HOME, TC, VIDEO, AUDIO, CUE, PF1, PF2, SET UP). You can register any frequently used items to the HOME, TC, VIDEO, AUDIO, PF1, and PF2 menu screens. By registering the necessary items in advance, setting operations are made quicker. The contents of the eight VTR memory banks can, in turn, be stored on a “Memory Stick” for later recall.

4-1-1 Menu Configuration

This VTR has two kinds of menus.

VTR SETUP menu list

This menu contains items that specify the initial operating conditions of the VTR. You can change these settings directly without registering the items to the function buttons.

Press the [F6] (VTR SETUP) button in the SET UP menu to display this menu.

For details on setting operating conditions of the VTR, see “4-7-1 VTR SETUP Menu” on page 99.

PF ASSIGN menu list

This is a list of menu items which can be registered to the HOME, TC, VIDEO, AUDIO, PF1 and PF2 menu screens as well as the screen that is displayed by pressing the ALT button (the ALT screen). This includes all VTR SETUP menu item.

Press the [F4] (PF ASSIGN) button in the SET UP menu to display this menu.

For details on registering items, see “4-1-3 Registering Items to the VTR SETUP Menu” on page 39.

The menu configuration of the VTR is shown in the following figure.

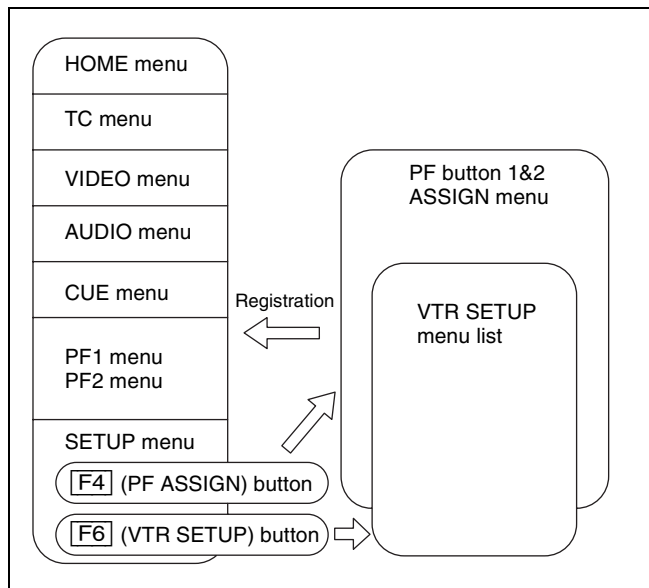

PF button assignment allows you to assign the same item also to a different menu screen or button.

4-1-2 Changing Menu Settings

To activate the HOME, TC, VIDEO, AUDIO, CUE, PF1, PF2, or SET UP menu, press the respective menu button. Menu items are assigned to function buttons ([F1] to [F10]) in each menu. When two items are registered to the same function button, you can display the second item by pressing the ALT button.

The example below describes the procedure for changing the setting specified by the ALT/[F6] (CHARA SUPER) button in the TC menu.

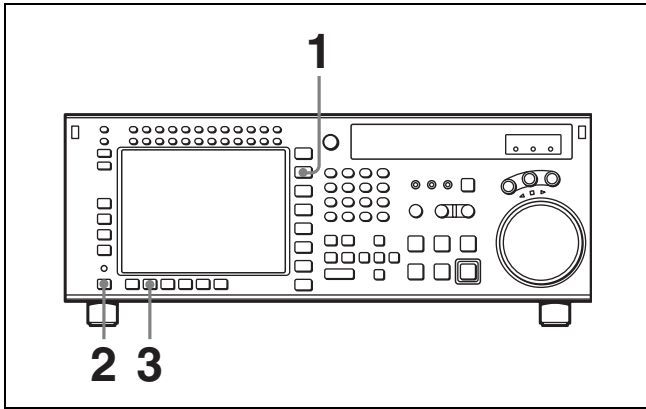

- 1** Press the TC button.

The first page of the TC menu appears in the display.

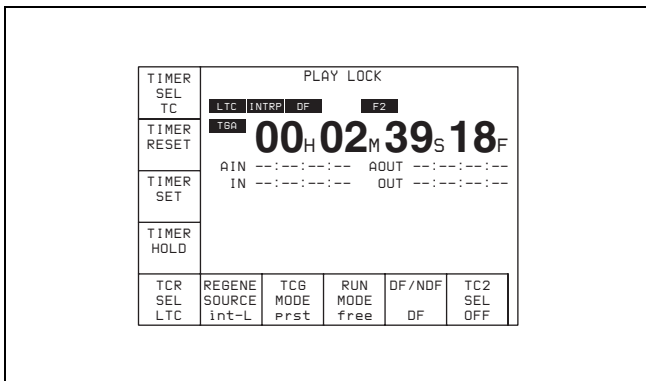

- 2** Press the ALT button.

The second page of the TC menu appears in the display.

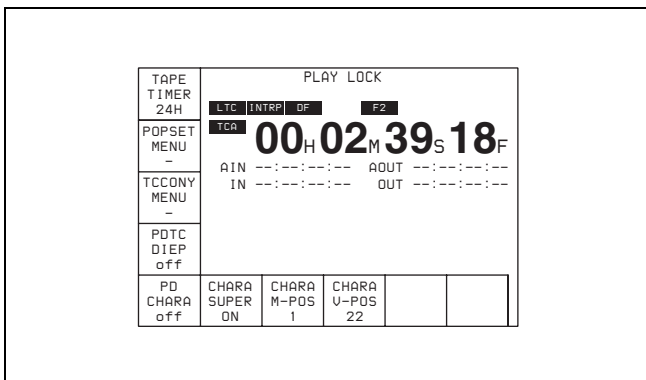

To return to the first page
Press the ALT button again.

- 3** Press the [F6] (CHARA SUPER) button to change the setting.
Each time the button is pressed, the setting changes.

4-1-3 Registering Items to the VTR SETUP Menu

You can register 120 menu items including those displayed by pressing the ALT button in the HOME, TC, VIDEO, AUDIO, PF1, and PF2 menus. By registering frequently used menu items, the settings can be carried out together.

Registering items

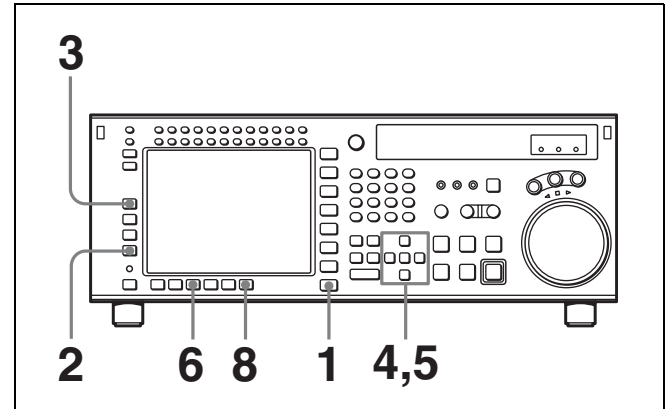

- 1** Press the SET UP button.

The SET UP menu appears in the display.

- 2** Press the [F4] (PF ASSIGN) button.

The PF ASSIGN menu appears in the display.

- 3** Press the [F1] (PAGE) button to select the menu where you wish to register an item.

The selected menu appears and the items currently registered to the menu appear in the middle of the display.

If the function button assignments are other than the default, the [F3] (PAGE DEF.) button is valid.

To return all function buttons to the default settings

Press the [F3] (PAGE DEF.) button.

- 4** Press the cursor ↑ or ↓ button to move the cursor (▶) to the function button where the item is to be registered.

The selected function button is highlighted and the current setting is displayed.

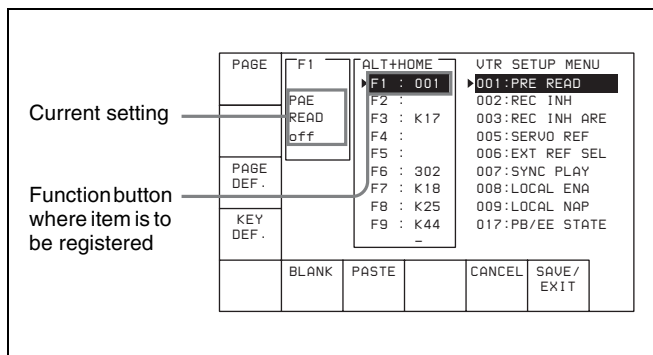

To unregister the selected item

Press the **[F6]** (BLANK) button.

When a function button with other than the default assignment is selected, the **[F4]** (KEY DEF.) button is valid.

To return the selected function button to its default setting, press the **[F4]** (KEY DEF.) button.

- Press the cursor **→** button to move the cursor (▶) to the menu list (PF ASSIGN menu), then press the cursor **↑** or **↓** button to move the cursor to the menu item to be registered.

To scroll the menu faster

Press the cursor **↑** or **↓** button while holding down the SFT button.

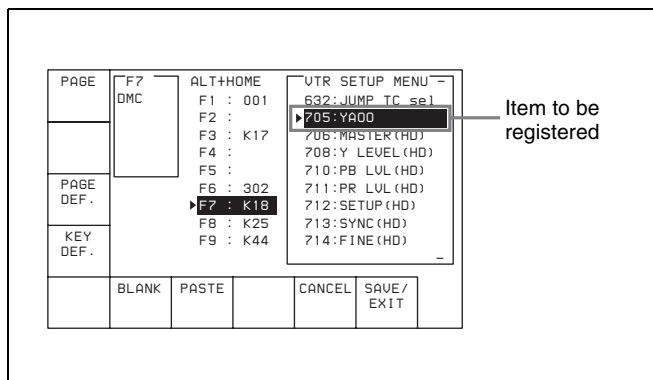

- Press the **[F7]** (PASTE) button to register the item.
The new item is registered to the function button.
- Repeat steps **3** to **6** to register more items.

To cancel the registration of all new items

Press the **[F9]** (CANCEL) button.

- Press the **[F10]** (SAVE/EXIT) button to save the newly registered items.

The registration is completed and the SET UP menu appears in the display again.

4-1-4 VTR Memory Bank Function

Eight VTR memory banks are provided for storing up to eight sets of menu settings.

The contents of all eight VTR memory banks can be stored on a “Memory Stick”.

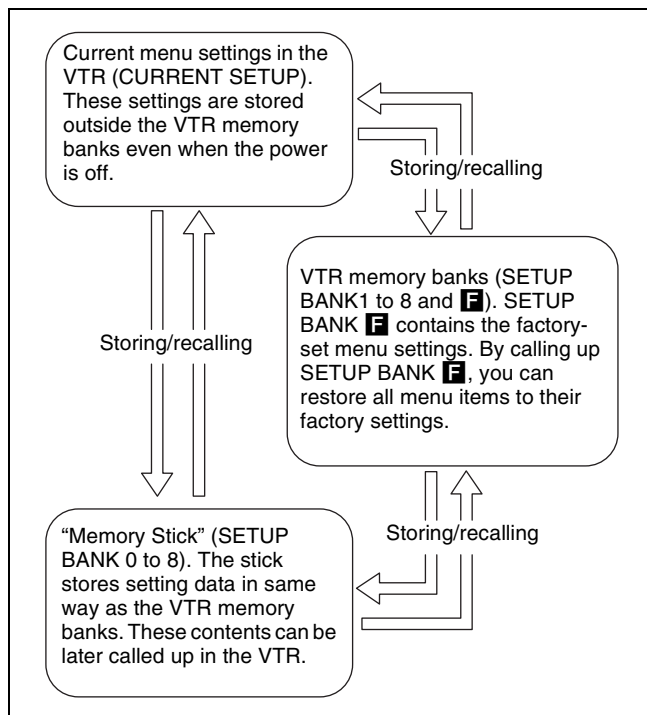

For details on “Memory Stick” use, see “4-1-5 “Memory Stick” Operations” on page 42.

For details on adding titles to the contents of the VTR memory bank, see “4-1-6 Adding Titles to the Data” on page 47.

Note

The contents of SETUP BANK **F** cannot be changed.

Storing the current VTR menu settings to a VTR memory bank

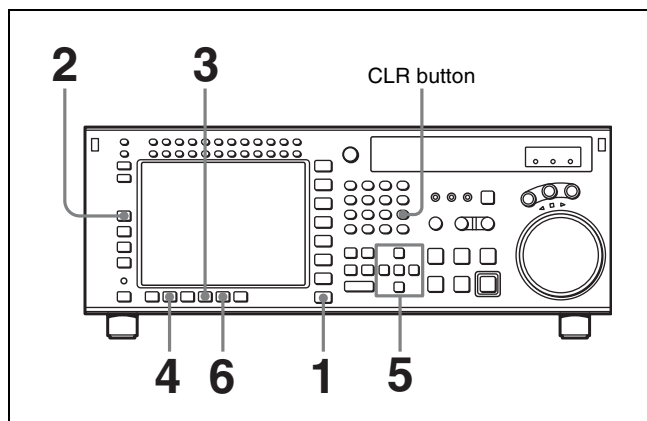

- 1 Press the SET UP button.

The SET UP menu appears in the display.

- 2 Press the [F1] (VTR BANK) button.

The VTR BANK menu appears in the display.

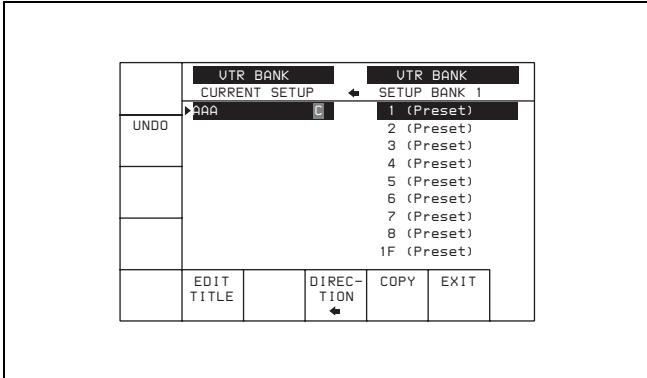

- 3 Press the [F8] (DIRECTION) button to select the ← direction.

- 4 Press the cursor ← button to move the cursor (▶) to CURRENT SETUP [C], then press the [F6] (EDIT TITLE) button to add a title to the current menu settings of the VTR.

For details, see “4-1-6 Adding Titles to the Data” on page 47.

- 5 Press the cursor → button to move the cursor (▶) to SETUP BANK, then press the cursor ↑ or ↓ button to move the flashing cursor bar to the number of the VTR memory bank to be used for saving the current menu settings.

The flashing cursor bar indicates the storage destination.

- 6 Press the [F9] (COPY) button.

A message appears in the display asking you to confirm the operation.

To cancel the storage operation

Press the CLR button.

- 7 Press the [F9] (COPY) button while holding down the SFT button.

The current menu settings are stored to the VTR memory bank.

To add or change a title for VTR settings after storing them to the VTR memory bank

Move the cursor (▶) to the number of the VTR memory bank where the settings are stored, then press the [F6] (EDIT TITLE) button.

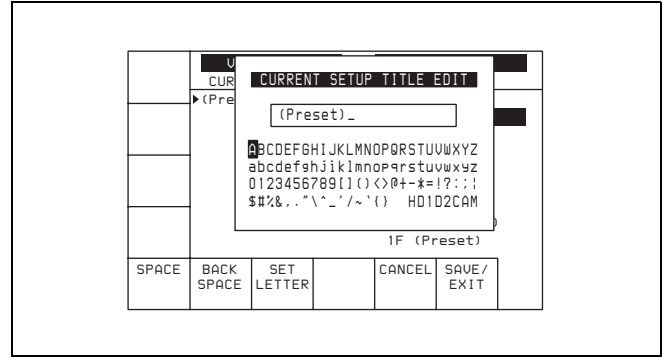

For more information, see “4-1-6 Adding Titles to the Data” on page 47.

Recovering previous settings after new settings have been saved

Press the [F2] (UNDO) button to recover the previous settings.

Preventing accidental erasure after saving settings

Move the cursor to the memory bank to be protected and press ALT/[F2] (PROTECT) buttons. A P will appear next to the selected bank.

- 8 Press the [F10] (EXIT) button.

The SET UP menu appears again.

Recalling menu settings from a VTR memory bank

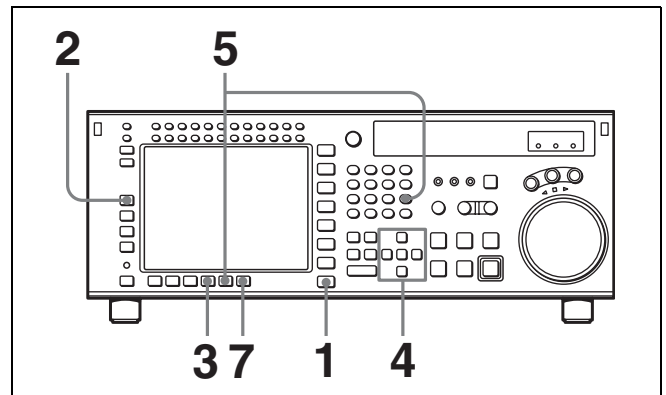

- 1 Press the SET UP button.

The SET UP menu appears in the display.

- 2 Press the [F1] (VTR BANK) button.

The VTR BANK menu appears in the display.

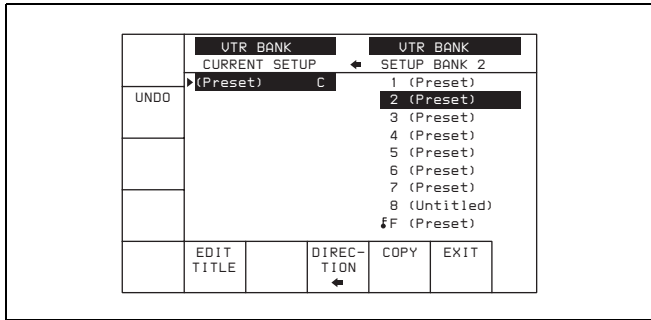

- 3** Press the **[F8]** (DIRECTION) button to select the ← direction.

The left cursor bar flashes.

- 4** Press the cursor ↑ or ↓ button to move the cursor (▶) to the number of the VTR memory bank to be recalled.

- 5** Press the **[F9]** (COPY) button.

A message asking you to confirm the operation appears in the display.

To cancel the recalling operation

Press the CLR button.

- 6** Press the **[F9]** (COPY) button while holding down the SFT button.

The menu settings are recalled from the selected VTR memory bank.

When the recalling process has been completed, the title of the VTR bank appears under CURRENT SETUP in the display.

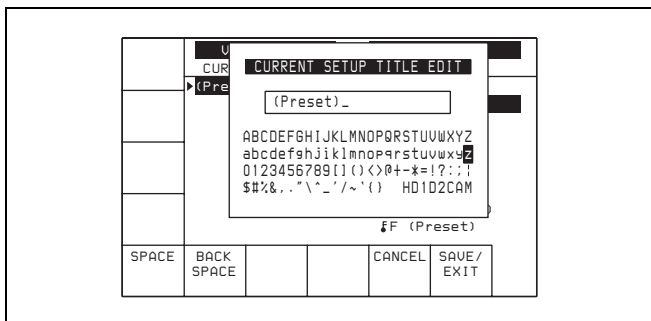

- 7** Press the **[F10]** (SAVE/EXIT) button.

The SET UP menu appears again.

4-1-5 “Memory Stick” Operations

You can store menu settings in the VTR memory banks and cue point data to a “Memory Stick” for recall later.

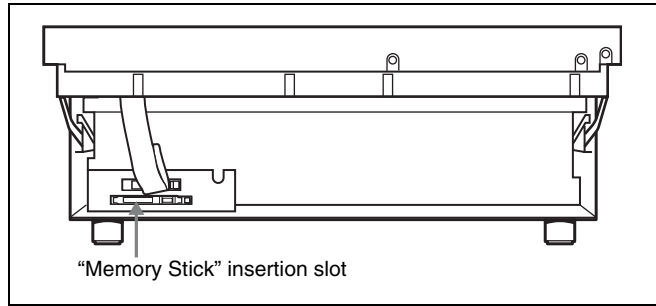

To eject the “Memory Stick”

Raise up the lower control panel, and press the button on the right side of the insertion slot.

For details of opening and closing the control panel, refer to the Maintenance Manual.

Notes

- When inserting a “Memory Stick”, press it firmly in as far as it will go. The stick recognition status is shown on the MEMCARD menu screen. If not inserted properly, reinsert it.
- While data is being read from or written to the “Memory Stick”, the status appears on the screen. During these operations, do not remove the “Memory Stick”.
- When no directory is found on the inserted “Memory Stick” for storing the settings of the SRW-5000/5500 (“SRW5000”), the message “CONFIRMATION OF CREATING DIR:” appears in the MEMCARD menu display. Press the **[F1]** (FORMAT CARD) button while holding down the SFT button to create a directory. To cancel creating a directory, press the CLR button.

Formatting a “Memory Stick”

The “Memory Stick” must be formatted before you can use it.

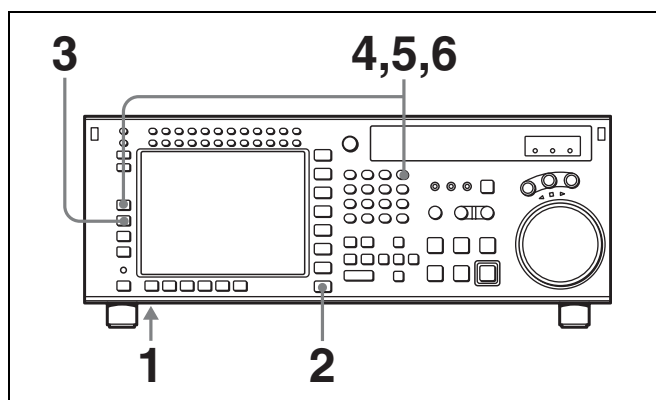

- 1** Insert the “Memory Stick”.

- 2** Press the SET UP button.

The SET UP menu appears in the display.

3 Press the **[F2]** (MEMORY CARD) button.

The MEMCARD menu appears in the display.

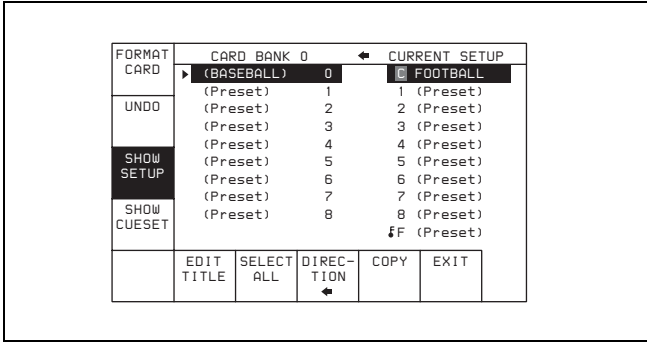

4 Press the **[F1]** (FORMAT CARD) button.

A message asking you to confirm the operation appears in the display.

To cancel formatting

Press the CLR button while the confirmation message appears in the display.

5 Press the **[F1]** (FORMAT CARD) button while holding down the SFT button.

The VTR starts formatting the “Memory Stick”.

Storing the contents of the VTR memory banks to a “Memory Stick”

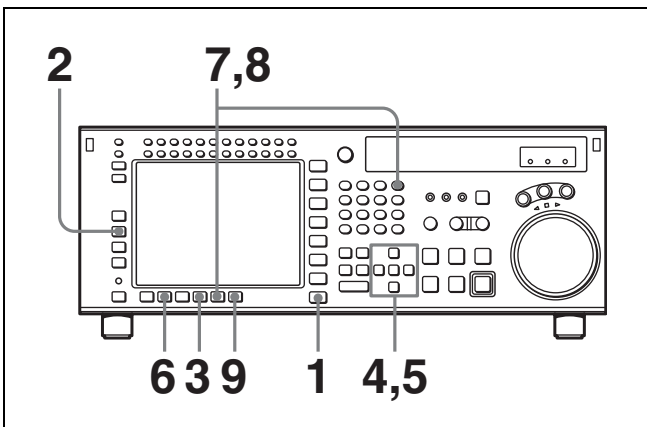

1 Press the SET UP button.

The SET UP menu appears in the display.

2 Press the **[F2]** (MEMORY CARD) button.

The MEMCARD menu appears in the display.

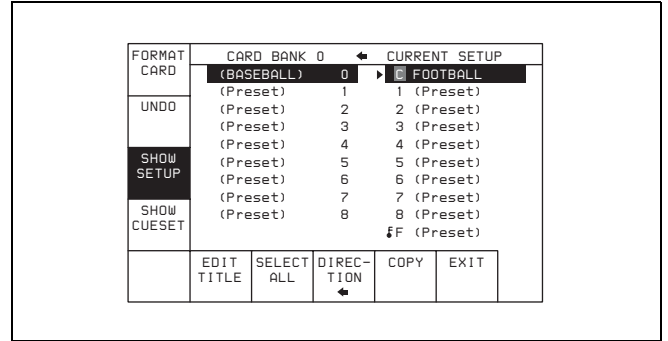

3 Press the **[F8]** (DIRECTION) button to select the ← direction.

The left cursor bar flashes.

4 Move the cursor ▶ to the VTR side using the cursor → button and use the cursor ↑ or ↓ button to move the cursor bar to the memory bank where the data is to be saved.

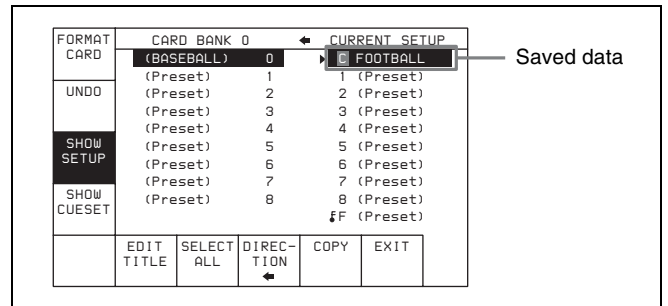

To store the current VTR menu settings

Move the cursor (▶) to the **[C]** (CURRENT SETUP) position.

To store all VTR memory banks

Press the **[F7]** (SELECT ALL) button.

Note

If there are protected items at the destination end, it is not possible to select the **[F7]** (SELECT ALL) button.

5 Move the cursor (▶) to the “Memory Stick” side using the cursor ← button, and use the cursor ↑ or ↓ button to move the cursor to the bank number (“Memory Stick” side) where the data is to be saved.

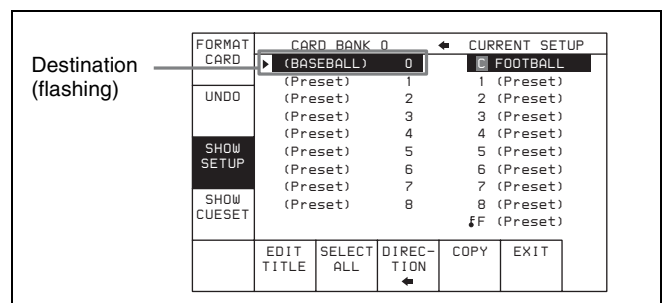

The flashing cursor bar indicates the storage destination.

- 6 To change the title of the bank, press the **[F6]** (EDIT TITLE) button.

For details, see “4-1-6 Adding Titles to the Data” on page 47.

- 7 Press the **[F9]** (COPY) button.

A message asking you to confirm the operation appears in the display.

- 8 Press the **[F9]** (COPY) button while holding down the SFT button.

Storage begins.

After the storage is complete, the title of the VTR memory bank appears on the “Memory Stick” side.

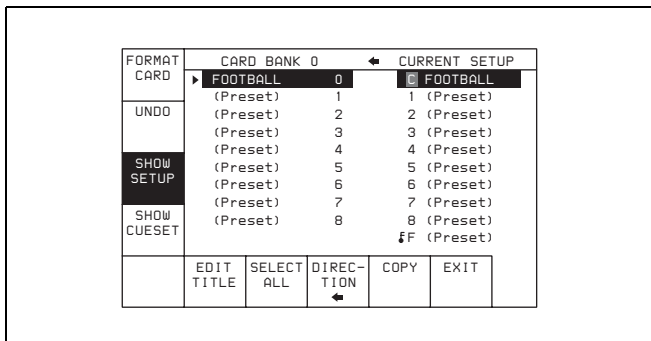

Preventing accidental erasure after saving settings

Press ALT/**[F2]** (PROTECT) buttons and a **f** symbol will appear to the right of the memory card bank number.

- 9 Press the **[F10]** (EXIT) button.

The SET UP menu appears again.

Storing cue point lists to a “Memory Stick”

You can store up to 8 pages of cue point lists to a “Memory Stick” along with titles.

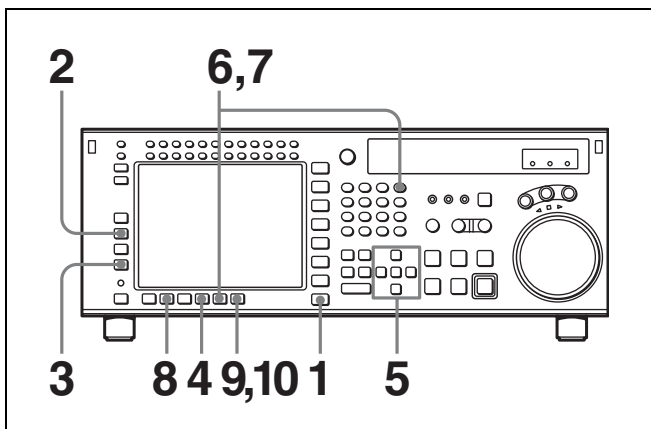

- 1 Press the SET UP button.

The SET UP menu appears in the display.

- 2 Press the **[F2]** (MEMORY CARD) button.

The MEMORY CARD menu appears in the display.

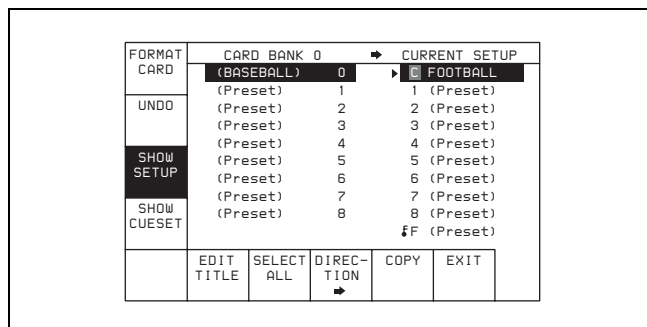

- 3 Press the **[F4]** (SHOW CUESET) button.

The display for storing cue point lists appears.

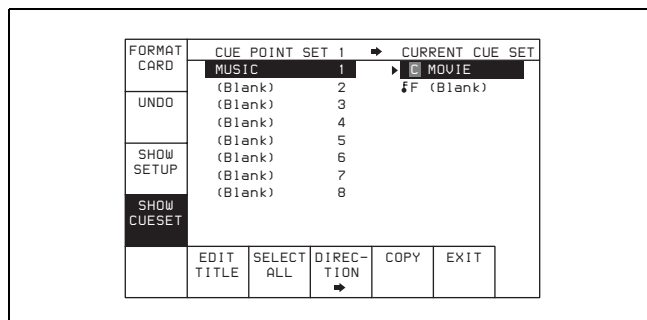

To return to the MEMORY CARD menu

Press the **[F3]** (SHOW SETUP) button.

- 4 Press the **[F8]** (DIRECTION) button to select the ← direction.

The left cursor bar flashes.

- 5 Use the cursor ← button to move the cursor (▶) to CUE POINT SET side, then press the cursor ↑ or ↓ button to move the cursor bar to the number of the memory bank in the “Memory Stick” where you want to store the cue point list.

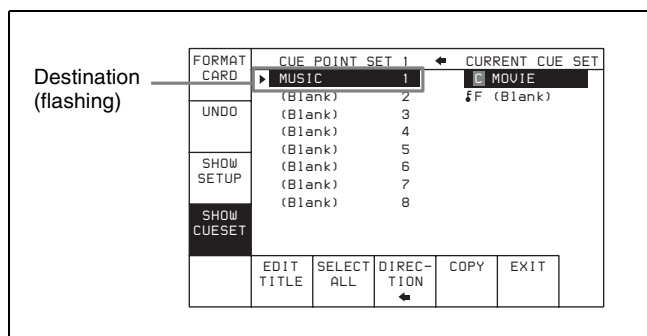

- 6 Press the **[F9]** (COPY) button.

A message asking you to confirm the operation appears in the display.

- Press the **[F9]** (COPY) button while holding down the SFT button.

The VTR stores the cue point list to the “Memory Stick”.

- Press the **[F6]** (EDIT TITLE) button to add a title to the cue point list.

For details, see “4-1-6 Adding Titles to the Data” on page 47.

Preventing accidental erasure after saving settings

Move the cursor (▶) to the cue point set number you wish to save and press ALT/[F2] (PROTECT) buttons. A **⌘** symbol will appear to the right of the cue point set number.

- Press the **[F10]** (EXIT) button.

The SET UP menu appears again.

Recalling the contents of a “Memory Stick”

The contents stored in a “Memory Stick” can be recalled to the current VTR memory bank.

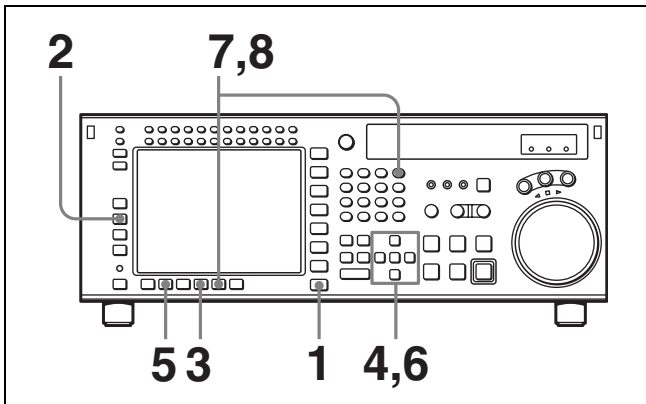

- Press the SET UP button.
The SET UP menu appears in the display.

- Press the **[F2]** (MEMORY CARD) button.
The MEMORY CARD menu appears in the display.

FORMAT CARD	CARD BANK 0	CURRENT SETUP
	(BASEBALL) 0	FOOTBALL
UNDO	(Preset) 1	1 (Preset)
	(Preset) 2	2 (Preset)
	(Preset) 3	3 (Preset)
	(Preset) 4	4 (Preset)
SHOW SETUP	(Preset) 5	5 (Preset)
	(Preset) 6	6 (Preset)
SHOW CUESET	(Preset) 7	7 (Preset)
	(Preset) 8	8 (Preset)
		⌘F (Preset)
	EDIT TITLE	SELECT ALL
	DIRECTION	COPY
		EXIT

- Press the **[F8]** (DIRECTION) button to select the → direction.

The right cursor bar flashes.

- Move the cursor (▶) to the “Memory Stick” side using the cursor ← button and use the cursor ↑ or ↓ buttons to place the cursor bar by the memory bank where the settings were saved.

Saved data

FORMAT CARD	CARD BANK 0	CURRENT SETUP
	(BASEBALL) 0	FOOTBALL
UNDO	(Preset) 1	1 (Preset)
	(Preset) 2	2 (Preset)
	(Preset) 3	3 (Preset)
	(Preset) 4	4 (Preset)
SHOW SETUP	(Preset) 5	5 (Preset)
	(Preset) 6	6 (Preset)
SHOW CUESET	(Preset) 7	7 (Preset)
	(Preset) 8	8 (Preset)
		⌘F (Preset)
	EDIT TITLE	SELECT ALL
	DIRECTION	COPY
		EXIT

- To change the title of the memory bank, press the **[F6]** (EDIT TITLE) button.
The title can also be changed after the settings are recalled.

For details, see “4-1-6 Adding Titles to the Data” on page 47.

- Press the cursor → button to move the cursor (▶) to the VTR side, then press the cursor ↑ or ↓ button to move the cursor to the VTR memory bank number where the recalled data are to be stored.

FORMAT CARD	CARD BANK 0	CURRENT SETUP
	(BASEBALL) 0	FOOTBALL
UNDO	(Preset) 1	1 (Preset)
	(Preset) 2	2 (Preset)
	(Preset) 3	3 (Preset)
	(Preset) 4	4 (Preset)
SHOW SETUP	(Preset) 5	5 (Preset)
	(Preset) 6	6 (Preset)
SHOW CUESET	(Preset) 7	7 (Preset)
	(Preset) 8	8 (Preset)
		⌘F (Preset)
	EDIT TITLE	SELECT ALL
	DIRECTION	COPY
		EXIT

Destination (flashing)

To change the current VTR menu settings
Move the cursor (▶) to [C] (CURRENT SETUP).

To replace all VTR memory bank contents with “Memory Stick” data

Press the [F7] (SELECT ALL) button.

Note

If there are protected items at the destination end, it is not possible to select the [F7] (SELECT ALL) button.

7 Press the [F9] (COPY) button.

A message asking you to confirm the operation appears in the display.

8 Press the [F9] (COPY) button while holding down the SFT button.

The VTR recalls the contents of the “Memory Stick”. After the recalling process is complete, the title of the memory bank of the “Memory Stick” appears under the VTR indication.

9 Press the [F10] (EXIT) button.

The SET UP menu appears again.

Recalling a cue point list from a “Memory Stick”

Recalling a cue point list from a “Memory Stick” replaces the current VTR cue point list with the recalled data.

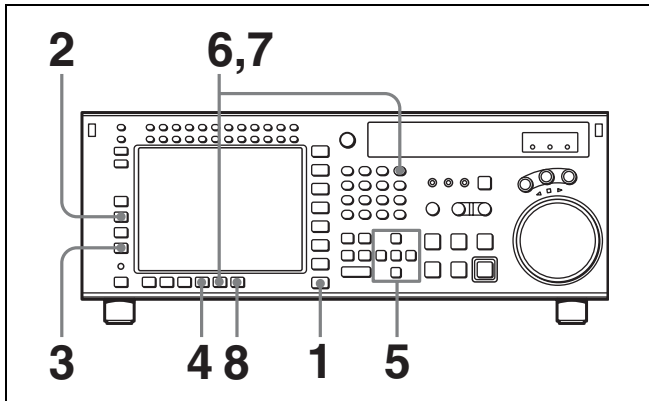

1 Press the SET UP button.

The SET UP menu appears in the display.

2 Press the [F2] (MEMORY CARD) button.

The MEMORY CARD menu appears in the display.

FORMAT CARD	CARD BANK 0	CURRENT SETUP
	(BASEBALL) 0	▶ FOOTBALL
	(Preset) 1	1 (Preset)
	(Preset) 2	2 (Preset)
	(Preset) 3	3 (Preset)
	(Preset) 4	4 (Preset)
	(Preset) 5	5 (Preset)
	(Preset) 6	6 (Preset)
	(Preset) 7	7 (Preset)
	(Preset) 8	8 (Preset)
		ⓂF (Preset)
	EDIT TITLE	SELECT ALL
		DIRECTION
		COPY
		EXIT

3 Press the [F4] (SHOW CUESET) button.

The menu for storing cue point lists appears.

FORMAT CARD	CUE POINT SET 1	CURRENT CUE SET
	MUSIC 1	▶ MOVIE
	(Blank) 2	ⓂF (Blank)
	(Blank) 3	
	(Blank) 4	
	(Blank) 5	
	(Blank) 6	
	(Blank) 7	
	(Blank) 8	
	EDIT TITLE	SELECT ALL
		DIRECTION
		COPY
		EXIT

To return to the MEMORY CARD menu
Press the [F3] (SHOW SETUP) button again.

4 Press the [F8] (DIRECTION) button to select the ➡ direction.

The right cursor bar flashes.

5 Use the cursor ← button to move the cursor (▶) to the CUE POINT SET side, then press the cursor ↑ or ↓ button to move the cursor bar to the number of the memory bank in the “Memory Stick”.

FORMAT CARD	CUE POINT SET 1	CURRENT CUE SET
▶ Saved data	MUSIC 1	▶ MOVIE
	(Blank) 2	ⓂF (Blank)
	(Blank) 3	
	(Blank) 4	
	(Blank) 5	
	(Blank) 6	
	(Blank) 7	
	(Blank) 8	
	EDIT TITLE	SELECT ALL
		DIRECTION
		COPY
		EXIT

6 Press the [F9] (COPY) button.

A message asking you to confirm the operation appears in the display.

7 Press the [F9] (COPY) button while holding down the SFT button.

The VTR recalls the cue point list in the “Memory Stick”.

After the recalling process is completed, the title of the cue point list appears under the CURRENT CUE SET indication

- 8 Press the **[F10]** (EXIT) button.

The SET UP menu appears again.

4-1-6 Adding Titles to the Data

When storing data to a memory bank in a “Memory Stick” or the VTR, you can add a title to the data to make data management easier.

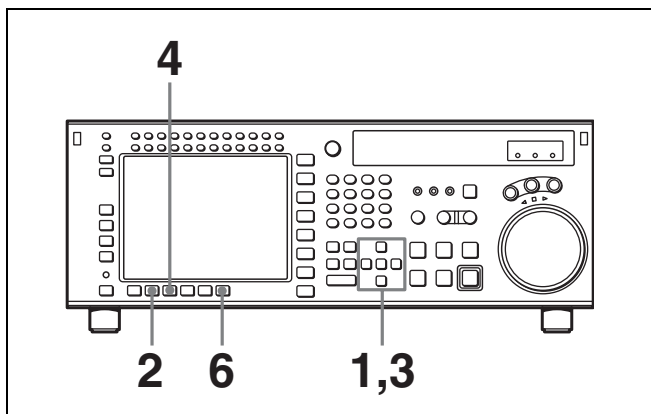

- 1 Move the cursor (▶) to the item to be titled.
- 2 Press the **[F6]** (EDIT TITLE) button to display the CURRENT SETUP TITLE EDIT window.

The VTR enters EDIT mode is entered, and the window opens.

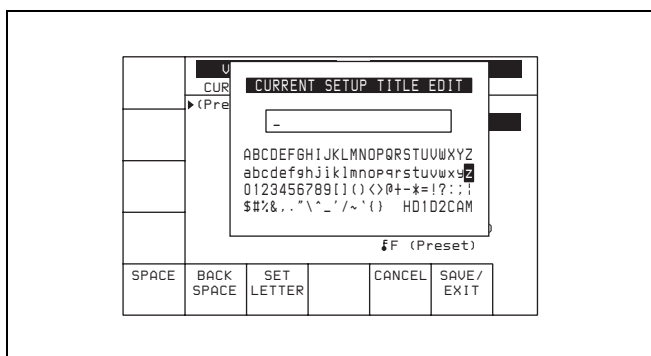

- 3 Press the cursor ← or → button to select a letter.

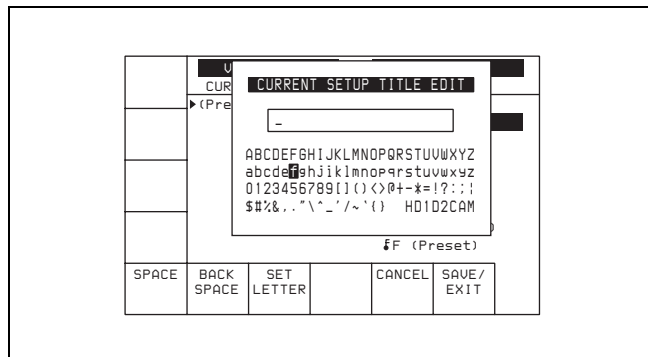

- 4 Press the **[F7]** (SET LETTER) button or the cursor center button.

The selected letter is entered.

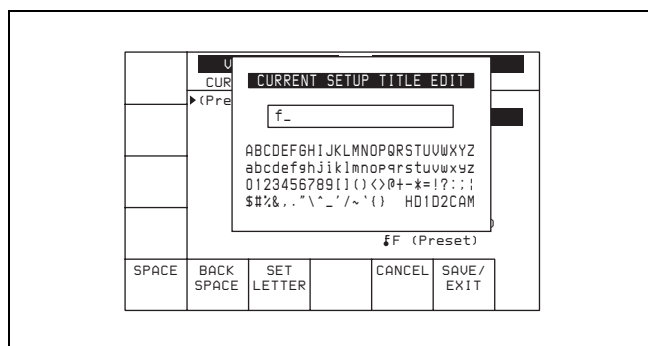

- 5 Repeat steps 3 and 4 to enter more characters.

To enter a space

Press the **[F5]** (SPACE) button.

If you enter a wrong character

Press the **[F6]** (BACK SPACE) button to go back, then reenter a character.

To cancel the procedure to start over again

Press **[F9]** (CANCEL) button to start over again.

To change a character

Press the cursor ↑ button to enter the title box, then press the cursor ← or → button to go to the text insertion position.

- 6 Press the **[F10]** (SAVE/EXIT) button.

The entered title is set and the menu displayed before you pressed the **[F6]** (EDIT TITLE) button appears again.

4-1-7 Details on VTR Memory Bank and “Memory Stick” Functions

Most settings of most items can be stored to a VTR memory bank or a “Memory Stick”.

Data that can be stored to/recalled from a VTR memory bank or a “Memory Stick”

- VTR SETUP data
- PF assignment data
- BANK titles

DEFAULT values for VTR SETUP can be saved and recalled. However, DEFAULT values do not include PF assignment data and BANK titles.

For details of saving and recalling DEFAULT values, see “4-1-10 Saving and Recalling DEFAULT Settings on a Bank” on page 49.

4-1-8 “Memory Stick” Data Compatibility

Data copied onto a “Memory Stick” can be used on control panels connected to other SRW-5000/5500 VTRs. Although data is completely compatible between VTRs with different optional equipment, take note of the following.

Consider data copied from VTR A to VTR B and then to VTR C

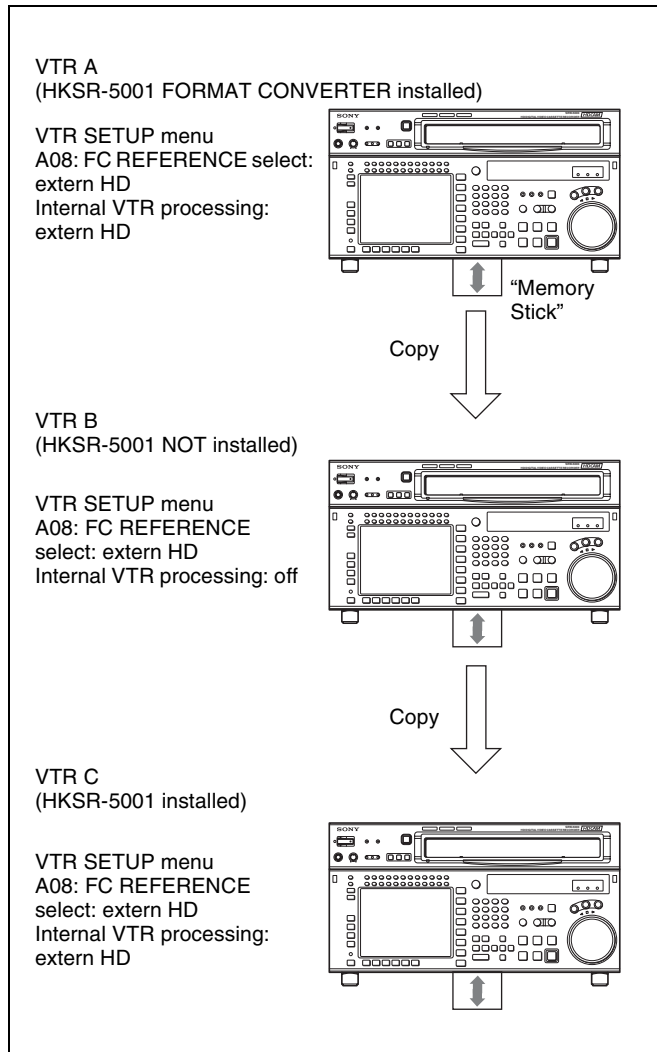

- Even though the optional equipment is different in VTRs A and B, the VTR SETUP menu settings are preserved.
- Even though the VTR SETUP menu settings are copied to VTR C after being copied to VTR B, the settings from VTR A are copied to VTR C.
- Even though settings are copied for optional equipment that is not present, the settings are adjusted and processed by the VTR internally.
- There is complete data compatibility between the SRW-5000 and SRW-5500. However, items which are not available on one model or the other do not appear in the VTR SETUP menu.
- There is no data compatibility between the SRW-5800 and SRW-5000/5500. However, VTR SETUP data for the SRW-5800 can be imported to the SRW-5000/5500.

4-1-9 Automatic Reading from a VTR Bank at Power On

By having the normally used settings saved in a bank, and recalled automatically when the system is powered on, you can always start operation from powering on with the same settings.

- 1 Make the VTR SETUP menu and PF assignment settings.
- 2 In the VTR BANK menu screen, save the current settings in any VTR bank.
It is preferable to add a title to identify the settings, and protect the settings not to be overwritten.

- 3 Press the ALT button.

This switches to the ALT + BANK menu screen.

- 4 Press the **[F4]** (POW-ON RECALL) button.

A red “P” appears to the left of the VTR BANK title. Each time you press the **[F4]** (POW-ON RECALL) button cycles the VTR bank from SETUP BANK 1 in sequence to the FACTORY PRESET item, and then to blank.

- 5 Press the ALT button, to return to the VTR BANK menu screen.

Next time you power on, the settings will automatically be recalled from SETUP BANK in the VTR bank with “P” set.

Note

Unless VTR SETUP menu item 116 “ALARM BEEP” is set to “off” to distinguish the automatic recall from a normal startup, a beep sound occurs twice.

4-1-10 Saving and Recalling DEFAULT Settings on a Bank

For each VTR SETUP menu item, you can change the factory DEFAULT value to a desired value.

For details, see “To change the DEFAULT values in a menu item” on page 101.

These changed DEFAULT values can be saved in a VTR BANK of the VTR.

- 1 Press the SET UP button.

The SETUP menu screen appears.

- 2 Press the ALT button.

The ALT + SETUP menu screen appears.

- 3 Press the **[F1]** (DEFAULT VTR BANK) button.

The DEFAULT VTR BANK screen appears.

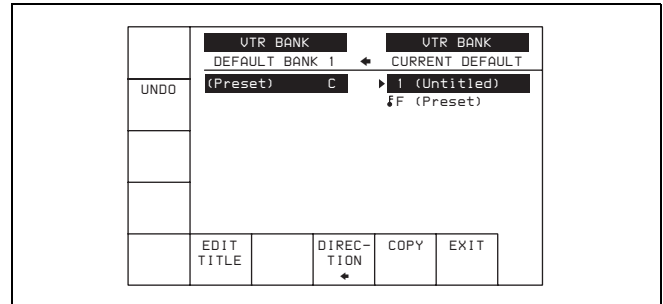

The procedure for saving from CURRENT DEFAULT to DEFAULT BANK, saving from DEFAULT BANK or FACTORY PRESET (factory setting) to CURRENT DEFAULT, changing the title, or setting protection, is the same as operation on a VTR bank.

For details, see “4-1-4 VTR Memory Bank Function” on page 40.

Notes

- The storage region for DEFAULT BANK is one set only.
- The title name shown in the current area is always that for the CURRENT SETUP data. When DEFAULT BANK data with the title changed is written to CURRENT DEFAULT, the title of the current area does not change. Also, when CURRENT DEFAULT settings are saved in DEFAULT BANK, the title of DEFAULT BANK is copied from the title of CURRENT SETUP.

4-1-11 Saving and Recalling DEFAULT Settings in a “Memory Stick”

For each VTR SETUP menu item, you can change the factory DEFAULT value to a desired value.

For details, see “To change the DEFAULT values in a menu item” on page 101.

The set DEFAULT values can be saved in a “Memory Stick”.

- 1 Insert a “Memory Stick”.

2 Press the SET UP button.

The SET UP menu screen appears.

3 Press the ALT button.

The ALT + SETUP menu screen appears.

4 Press the **[F2]** (DEFAULT MEMORY CARD) button.

The DEFAULT MEMORY CARD screen appears.

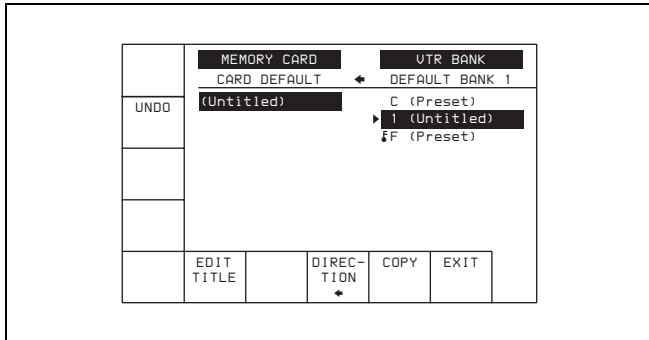

The procedure for saving from CARD DEFAULT to DEFAULT BANK or CURRENT DEFAULT, saving from DEFAULT BANK, CURRENT DEFAULT or FACTORY PRESET to CARD DEFAULT, changing the title, or setting protection, is the same as operation on a VTR bank.

For details, see “4-1-5 “Memory Stick” Operations” on page 42.

Notes

- The storage region for CARD DEFAULT is one set only.
- The title shown in the current area is always that for the CURRENT SETUP data. When CARD DEFAULT data with the title changed is written to CURRENT DEFAULT, the title of the current area does not change. Also, when CURRENT DEFAULT settings are saved in DEFAULT BANK, the title of DEFAULT BANK is copied from the title of CURRENT SETUP.
- There is complete data compatibility between the SRW-5000 and SRW-5500.

On how to check the items for which DEFAULT values have been changed from FACTORY PRESET values, see “To check the items for which DEFAULT values have been changed” on page 101.

4-2 HOME Menu

The HOME menu sets the basic VTR operation conditions for recording, playback, and editing.

The HOME, VIDEO, AUDIO, TC, PF1 and PF2 menus show information that includes the VTR operation mode, time code of the current position, and time code type, etc.

To activate the HOME menu

Press the HOME button.

To change the HOME menu page

Press the ALT button.

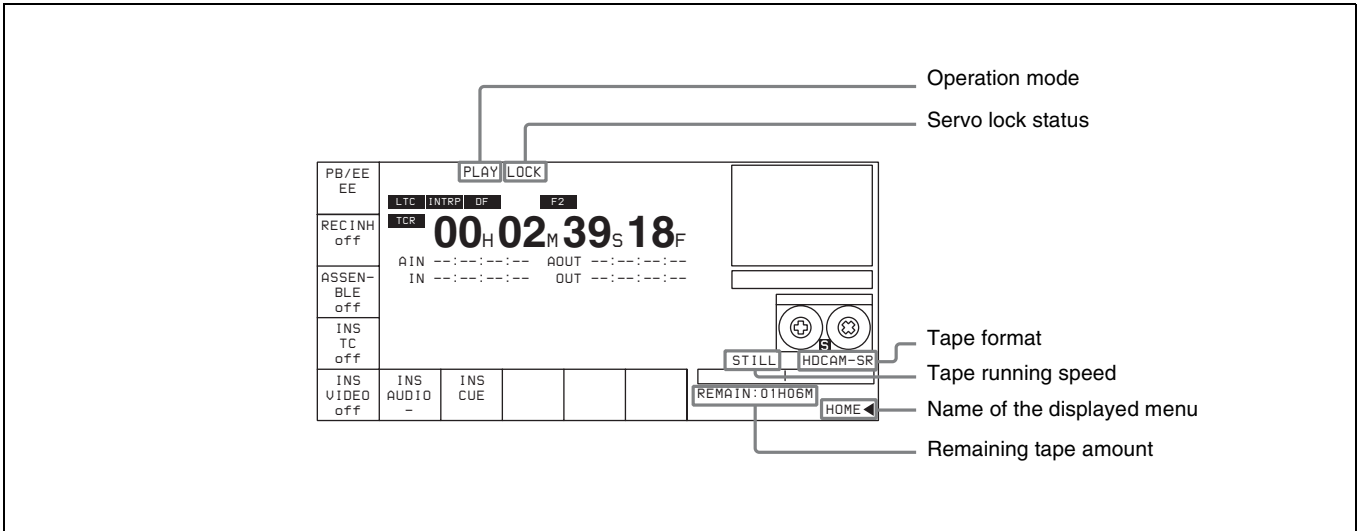

For details on time codes, see “4-3 TC Menu” on page 57.

Button	Indication	Function	Settings
[F1]	PB/EE	Selects of output signals	PB, EE
[F2]	REC INH	Disables recording	on, off
[F3]	ASSEMBLE	Selects edit mode and edit channel	
[F4]	INS TC	Selects TC insert editing mode	
[F5]	INS VIDEO	Selects VIDEO insert editing mode	
[F6]	INS AUDIO	Opens the INS AUDIO menu	
[F7]	INS CUE	Selects CUE insert editing mode	on/off (SRW-5500 only)
ALT/[F1]	PRE READ	Makes a setting for pre-reading	off/on/video only
ALT/[F3]	FREEZE	Selects still-picture output	
ALT/[F6]	PREROLL	Sets the preroll time	0 to 30 s
ALT/[F7]	DMC	DMC mode	on, off
ALT/[F8]	STOP CODE	Sets the stop code	
ALT/[F9]	PB EE SEL	Selects the output signal in various operation modes	
ALT/[F10]	LAST EDIT	Restores the last edit point set	

4-2-1 Selecting the Output Signals (PB/EE)

The audio/video output signals from the line output and monitor output connectors can be temporarily changed from their current settings to another set of settings by pressing the **[F1]** (PB/EE) button. The video, digital audio, and analog cue channel output signals are toggled to the other set of settings while the button is pressed.

Output signal selection

Select the output signal with ALT/**[F9]** (PB EE SEL) or VTR SETUP menu item 017 “PB/EE SELECT MENU”. Output signal types for different operation modes of this VTR are shown below.

Output Channel VTR Operation Mode	Video/Audio	
Standby off	EE/EE	PB/MUTING
Standby on	PB/MUTING	EE/EE EE/MUTING
Playback	PB/PB ^{a)}	
Record	EE/EE	PB/PB
Shuttle ^{c)}	PB/MUTING	EE/EE PB/PB
Jog	PB/PB	PB/MUTING
Variable	PB/PB	PB/MUTING
INPUT CHECK button	INPUT ^{b)}	

- a) Output signals during playback are PB/PB only. Output signals cannot be selected with the VTR SETUP menu item 017 “PB/EE SELECT MENU”.
 b) When the INPUT CHECK button is held down, the INPUT signals (audio and video) are output. Output signals cannot be selected with the VTR SETUP menu item 017 “PB/EE SELECT MENU”. When the INPUT signals are output, only monitor output is changed. Line output signals are not changed.
 c) Pressing the **[F1]** (PB/EE) button changes the output signals during shuttle mode in the following ways.

VTR SETUP menu item 017 “PB/EE SELECT MENU”	Output signals while the [F1] (PB/EE) button is held down
PB/MUTING	EE/EE
PB/PB	EE/EE
EE/EE	PB/MUTING

Note

When PB/PB is selected in shuttle mode during HDCAM playback, audio output is muted for playback speeds other than -1 to +2 times normal speed.

4-2-2 Record Inhibit Mode (REC INH)

Record inhibit mode is selected by pressing the **[F2]** (REC INH) button. Every time the button is pressed, the setting toggles between “off” and “on”.

The record inhibit area is selected using the VTR SETUP menu item 003 “REC INHIBIT AREA select”.

all: All recording is prohibited. (The REC INHIBIT indicator lights.)

crash REC: The normal record mode is disabled. Use this setting when you want to record only during assemble editing or insert editing.

video/CTL: Video and CTL signal recording is inhibited.

audio/CTL: Audio and CTL signal recording is inhibited.

casst: This is displayed when recording is inhibited because the record-protect plug is set. This setting cannot be selected.

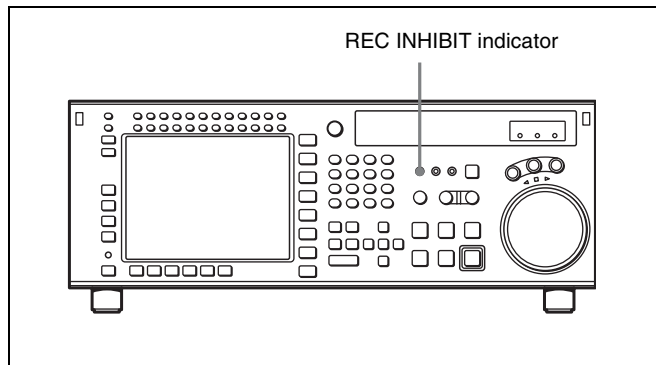

4-2-3 Selecting the Edit Mode and Edit Channel (ASSEMBLE, INS TC, INS VIDEO, INS AUDIO and INS CUE)

Select assemble or insert edit mode.

Selecting assemble edit mode

Press the **[F3]** (ASSEMBLE) button in the HOME menu.

Selecting the insert edit mode

Press one of the following INSERT buttons in the HOME menu: **[F4]** (INS TC), **[F5]** (INS VIDEO), **[F6]** (INS AUDIO), **[F7]** (INS CUE (SRW-5500 only)).

For more information about editing operations, see “Chapter 6 Editing” on page 116.

4-2-4 Preread Settings (PRE READ)

This setting allows pre-reading (reading before writing) in insert edit mode. To select pre-reading, press the ALT/[F1] (PRE READ) buttons.

Pressing the buttons cycles the settings through on/off.

on: Preread both video signal and audio signal.

off: No pre-reading

video only: Preread video signal only.

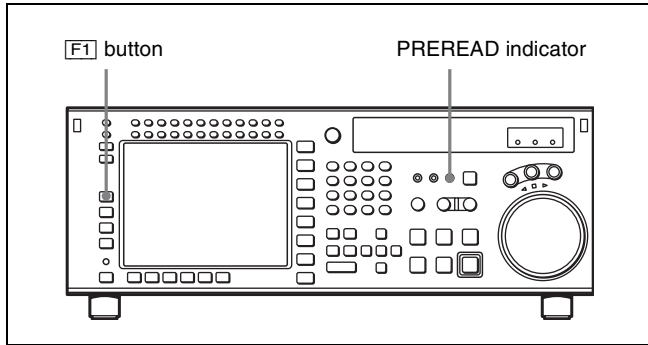

The pre-read function can be used for pre-read editing.

4-2-5 Still-Picture Output (FREEZE)

For still-picture output, press the ALT/[F3] (FREEZE) buttons. The picture that was playing just before the button was pressed will be frozen on the screen. Make the field or frame selection using the VTR SETUP menu item 902 "FREEZE MODE".

To maintain the still-picture

Set the VTR SETUP menu item 903 "FREEZE CONTROL FROM KEY PANEL" to "latch".

The still-picture output is maintained until the button is pressed again.

To temporarily output a still-picture

Set the VTR SETUP menu item 903 "FREEZE CONTROL FROM KEY PANEL" to "momentary". A still-picture is output as long as you hold down the button.

Stop-freeze function

To automatically output a still-picture when the VTR is changed to stop mode, set the VTR SETUP menu item 905 "STOP FREEZE CONTROL" to "enable".

Note

Regardless of the setting of the VTR SETUP menu item 902 "FREEZE MODE", stop-freeze is a frame-freeze picture during playback of a PsF recorded tape, and a field-freeze picture in other modes.

4-2-6 Setting the Preroll Time (PREROLL TIME)

Set the preroll time by pressing the ALT/[F6] (PREROLL) buttons.

You can set a preroll time of 0 to 30 seconds in 1-second units. During editing on this VTR, a preroll time of 5 seconds or more is recommended.

Setting the preroll time

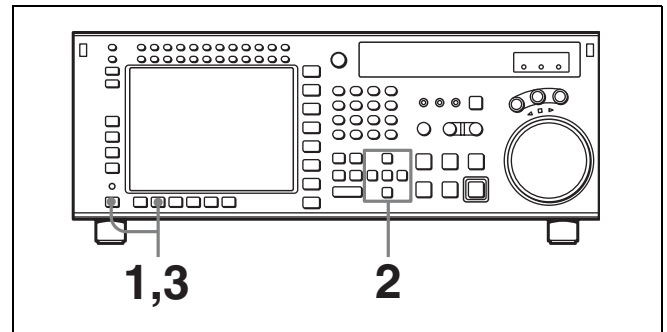

1 Press the ALT/[F6] (PREROLL) buttons.

A data entry window appears.

2 Change the setting with the cursor ↑ or ↓ button.

You may also use the MULTI CONTROL knob.

3 Press the ALT/[F6] (PREROLL) buttons.

The data entry window disappears.

4-2-7 Selecting DMC Playback (DMC)

In DMC (Dynamic Motion Control) playback mode, the VTR plays back a tape segment at a specified variable speed of -1 to +2 times normal playback speed, memorizes the speed, then plays the segment back at a later time at the memorized speed.

DMC playback is useful during on-the-spot telecasts of sporting events for immediate playback and broadcast of highlight scenes for which starting and ending points have been set during recording.

For detail on the procedure for DMC playback, see "5-4-4 DMC Playback" on page 112.

During tape editing using two SRW-5000/5500 VTRs, you can use DMC playback to control the playback speed of the player VTR for editing at variable speeds (DMC editing).

For detail on the procedure for DMC editing, see “6-2-1 DMC Editing” on page 127.

4-2-8 Setting the Stop Code (STOP CODE)

You can select the stop code detection mode (recording/confirmation/deletion), and adjust the stop position when a stop code is detected.

To call up the STOP CODE menu screen

Press the ALT/[F8] (STOP CODE) buttons in the HOME menu.

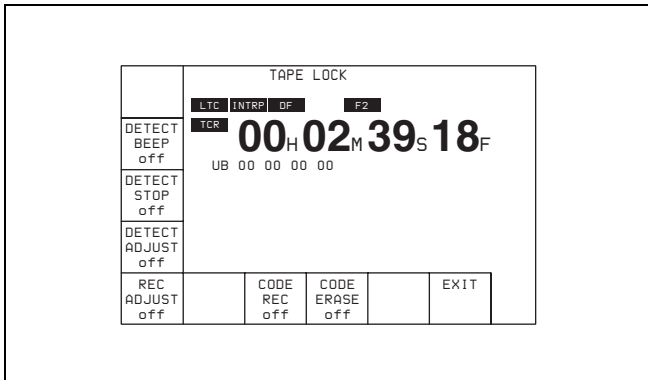

Note

If DETECT STOP is set to “ON”, “D-STOP” appears at the side of the cassette indication, as shown in the following figure.

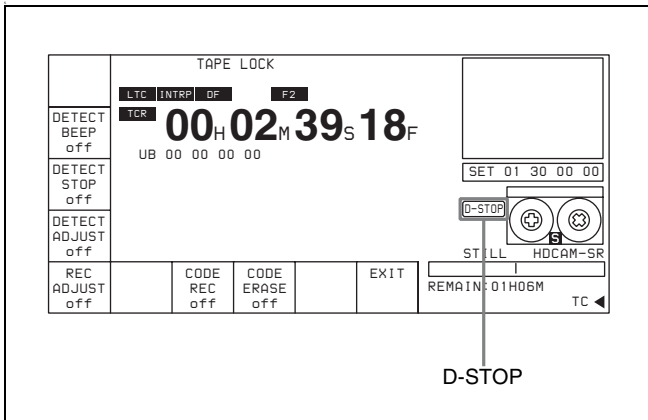

To detect stop codes: [F2], [F3]

When playing a tape on which stop codes are recorded, you can select four different operation modes, according to the settings of the [F2] (DETECT BEEP) button and [F3] (DETECT STOP) button, as follows.

[F2] (DETECT BEEP) button	[F3] (DETECT STOP) button	VTR operation when stop code is detected
OFF	OFF	No operation

[F2] (DETECT BEEP) button	[F3] (DETECT STOP) button	VTR operation when stop code is detected
OFF	ON	Stops (for NORMAL PLAY only)
ON	OFF	A beeper sounds for 1 second
ON	ON	Stops (for NORMAL PLAY only) and simultaneously a beeper sounds for 1 second

The tape transport modes and speed ranges in which stop codes can be detected are as follows.

Transport mode and speed	Detected	Beeper timing	Stop timing
NORMAL PLAY	Yes	When read three times	Set by [F4] (DETECT ADJUST)
VAR, SHUTTLE (0 to less than ± 8 times normal speed)	Yes	When read twice	No operation
REC, EDIT, JOG, CUE UP, PREROLL, SHUTTLE (± 8 times normal speed or more)	No	No operation	No operation

Note

In VAR mode, stop codes cannot be detected at ± 0.03 times normal speed.

Adjusting the stop position when a stop code is detected: [F4]

When a stop code is detected, you can adjust the position at which the tape transport stops in the direction from the normal stop position toward the SOM point, within the range of 0 to 150 frames, in frame units.

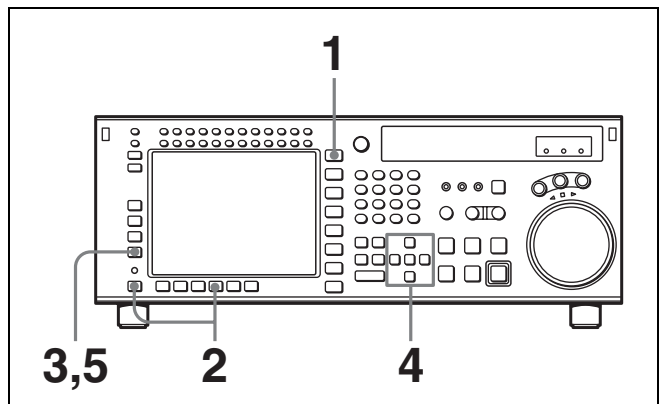

1 Press the HOME button.

The HOME menu screen appears.

- 2** Press the ALT/[F8] (STOP CODE) button.
The STOP CODE menu screen appears.
- 3** Press the [F4] (DETECT ADJUST) button.
The setting display lights up.
- 4** Change the setting with the cursor ↑ or ↓ button.
You may also use the MULTI CONTROL knob.
- 5** Press the [F4] (DETECT ADJUST) button.
The data entry window disappears.

Recording stop codes: [F7]

To record stop codes, press the [F7] (CODE REC) button. In PLAY, JOG, or similar mode, cue up to the SOM point, and press the REC/EDIT button. With the point at which the REC/EDIT button is pressed as the SOM point, after a preroll, the recording operation starts, and as shown in the figure below, user bits (value 0) and stop code are recorded, after which the unit automatically stops. After recording is completed, the setting of the [F7] (CODE REC) button is automatically changed to OFF.

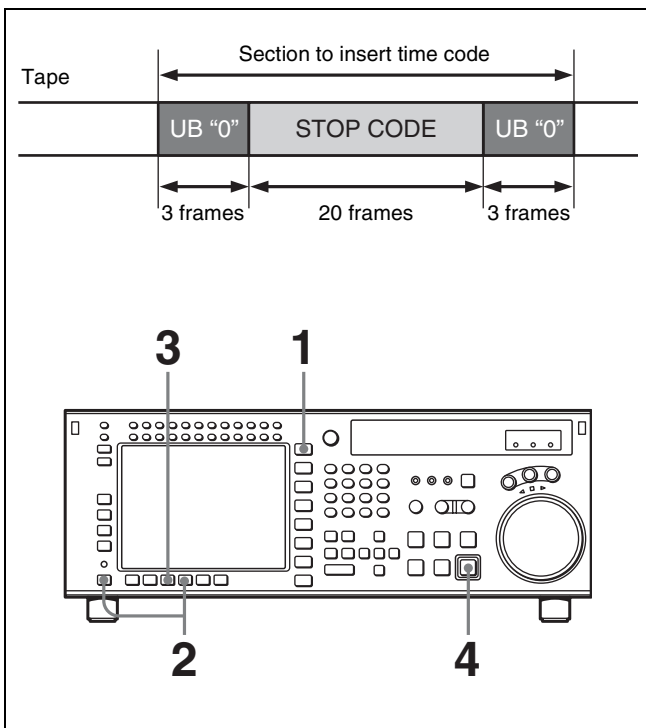

- 1** Press the HOME button.
The HOME menu screen appears.
- 2** Press the ALT/[F8] (STOP CODE) buttons.
The STOP CODE menu screen appears.

- 3** Press the [F7] (CODE REC) button to select “on”.
Pressing the button toggles between “on” and “off”.
- 4** Press the REC/EDIT button.

To abandon the operation at any point

Press the STOP button.

To specify the recording start position

Press the [F5] (REC ADJUST) button, to specify how many seconds before the SOM point the recording of the stop code should start.

To check the recording

Press the PREVIEW/REVIEW button. The tape prerolls to the SOM point and playback starts. If the stop code is correctly recorded, regardless of the settings of the [F2] (DETECT BEEP) button and [F3] (DETECT STOP) button, a confirmation sound is emitted for 1 second, and the unit stops in accordance with the setting of the [F4] (DETECT ADJUST) button. If the unit does not stop even after passing the point at which the stop code is recorded, repeat the recording operation.

Note

Checking the recording with the PREVIEW/REVIEW button is only valid in the stop code menu screen.

Deleting stop codes: [F8]

To delete a stop code, press the [F8] (CODE ERASE) button. In stop code detection mode, stop the VTR at the stop code you want to delete, and press the REC/EDIT button. After prerolling 5 seconds before the stop code recording point, the VTR begins the delete operation, and as shown in the figure below, user bits (value 0) are recorded, after which the unit automatically stops. After deletion is completed, the setting of the [F8] (CODE ERASE) button is automatically changed to OFF.

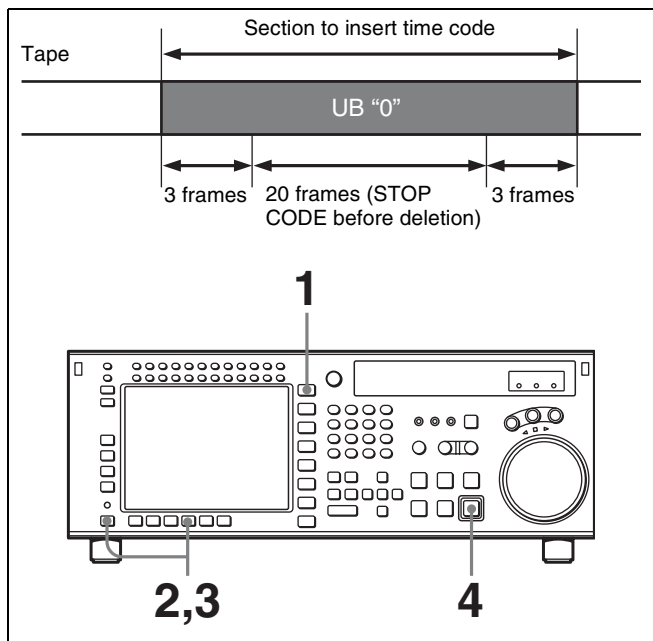

- 1** Press the HOME button.
The HOME menu screen appears.
- 2** Press the ALT/[F8] (STOP CODE) buttons.
The stop code menu screen appears.
- 3** Press the [F8] (CODE ERASE) button to select “on”.
Pressing the button toggles between “on” and “off”.
- 4** Press the REC/EDIT button.

To abandon the operation at any point

Press the STOP button.

To check the deletion

Press the PREVIEW/REVIEW button. The VTR prerolls 5 seconds before the recording point, and starts playback. If the unit stops at the point at which the stop code was recorded, repeat the deletion operation.

Note

Checking the deletion with the PREVIEW/REVIEW button is only valid in the stop code menu screen.

4-3 TC Menu

The TC menu allows you to set time code-related items through a single menu. The HOME, TC, VIDEO, AUDIO, PF1 and PF2 menus show information that includes the VTR operation mode, time code of the current position, and the time code type, etc.

To activate the TC menu
Press the TC button.

To change the TC menu page
Press the ALT button.

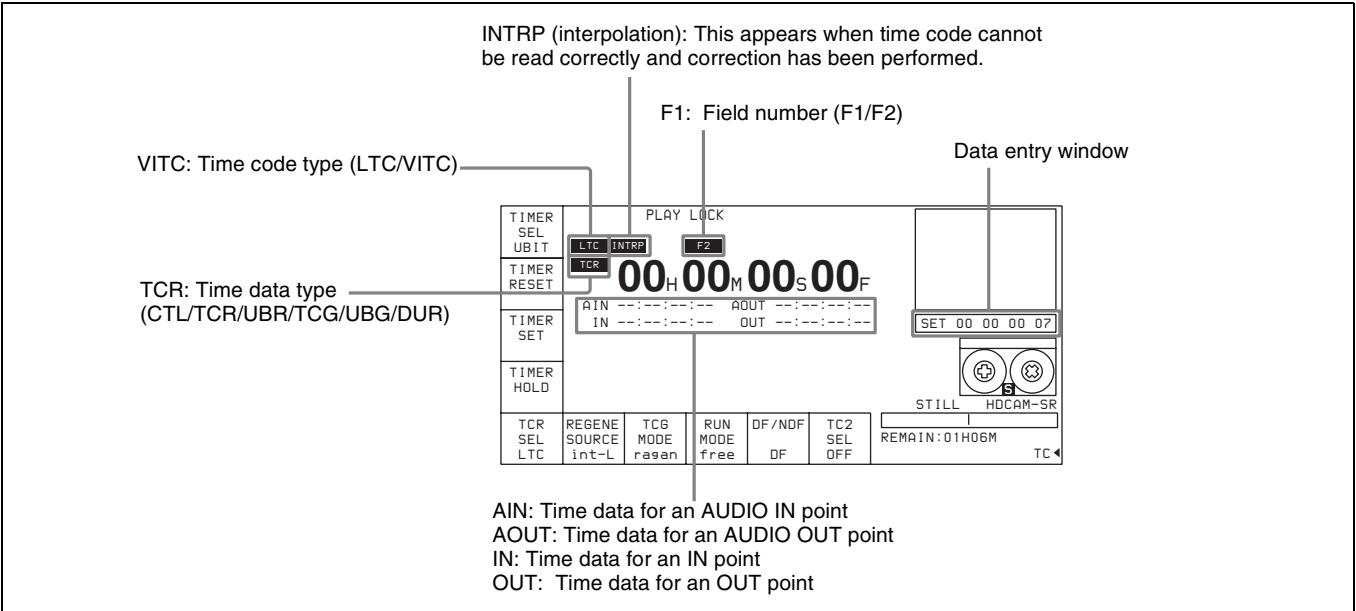

For details on operation modes, see “4-2 HOME Menu” on page 51.

Button	Indication	Function	Settings
[F1]	TIMER SEL	Selects time data type.	CTL, TC, UBIT
[F2]	TIMER RESET	Resets the time counter.	
[F3]	TIMER SET	Sets the time data.	
[F4]	TIMER HOLD	Holds the time counter.	
[F5]	TCR SEL	Sets the time code reader.	VITC, auto, LTC
[F6]	REGENE SOURCE	Selects the internal or external time code generator for TCG regeneration.	int-Lint-V ext-L SDI-VSDI-L
[F7]	TCG MODE	Sets the time code generator.	regene, prst, auto
[F8]	RUN MODE	Selects the running mode of the time code.	free, rec
[F9]	DF/NDF	Selects drop frame mode.	DF, NDF, auto
[F10]	TC2 SEL	Selects the content of the second line of the time code display.	OFF, LTC, auto, VITC, CTL, UBR, UBV, TCG, UBG
ALT/[F1]	TAPE TIMER	Selects the CTL display mode.	+ -12H, 24H
ALT/[F2]	PDPSET MENU	Pulldown time code preset	
ALT/[F3]	TC CONV MENU	Frame conversion time code preset	
ALT/[F4]	PDTC DISP	Pulldown time code display	on, off
ALT/[F5]	FC CHARA	Superimposition of text data on FC output	on, off
ALT/[F6]	CHARA SUPER	Specifies superimposition of character information to the HD SDI output and HD-SD converter output.	on, off
ALT/[F7]	CHARA H-POS	Changes the superimposition position (horizontal).	0 to 15
ALT/[F8]	CHARA V-POS	Changes the superimposition position (vertical).	0 to 15

4-3-1 Setting the Time Data (TIMER SEL/RESET/SET/HOLD)

The display shows the following types of time data:

Indication	Superimposed display	Time data type
TCR LTC	TCR	The LTC ¹⁾ value read by the time code reader during playback.
TCR VITC	TCR	The VITC ¹⁾ value read by the time code reader during playback.
TCG	TCG	The value generated by the time code generator during recording.
CTL	CTL	The number of CTL signals ²⁾ on the tape during recording/playing.
UBR LTC	UBR	The user bits ³⁾ value read by the time code reader (LTC) during playback.
UBR VITC	UBR	The user bits value read by the time code reader (VITC) during playback.
UBG	UBG	The user bits value generated by the time code generator during recording.
DUR	DUR	Appears whenever a duration between any two edit points (IN, OUT, AUDIO IN or AUDIO OUT points) is displayed.

1) LTC and VITC

LTC cannot be read when the tape speed is very slow or is changed suddenly. VITC, on the other hand, can be read more accurately than LTC when the VTR is stopped or the tape speed is very low. VITC, however, cannot be read when the tape speed is very fast.

2) CTL signals

CTL (control) signals are pulse signals that are recorded horizontally in each frame.

3) User bits

These represent supplementary information as part of the recorded time code, and consist of eight hexadecimal digits (0-9 and A-F).

Time data for IN, OUT, AIN and AOUT points are also displayed.

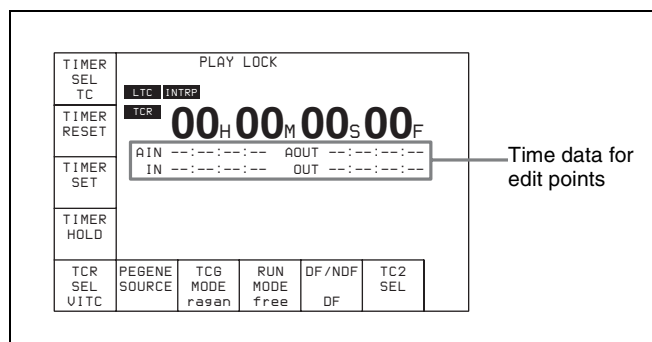

Selecting the time data display

Press the [F1] (TIMER SEL) button repeatedly to select the desired time data display.

CTL: Counts the CTL signals on the playback tape or the CTL signals being recorded on the tape, and displays the tape running time in hours, minutes, seconds, and frames.

TC: Displays the value read by the time code reader or the value generated by the time code generator. To switch between VITC and LTC, press the [F5] (TCR SEL) button.

UBIT: Displays user bits data inserted in time code being played back, or the user bits data inserted in time code being recorded. To switch between VITC and LTC, press the [F5] (TCR SEL) button.

Selecting the time code and the user bits to be recorded

Use the **[F6]**, **[F7]**, and **[F9]** buttons in the TC menu to specify the time code and the user bits to be recorded. The specifications for the various button settings are shown in the following table.

[F7] (TCG MODE)	[F6] (REGENE SOURCE)	[F9] (DF/NDF)	Time code and user bits recorded
prst		DF/NDF/auto ¹⁾	TC/UB enables TUG/UBG values to be recorded. Any time code can be specified for the time code generator and the user bits generator. The running mode for the recorded time code data conforms to that specified by the [F9] button.
regene ²⁾	int-L		TC/UB enables TUG/UBG values to be recorded. The time code generator and the user bits generator lock to the time data recorded longitudinally on the tape.
	int-V		TC/UB enables TUG/UBG values to be recorded. The time code generator and the user bits generator lock to the time data recorded in the video signal AUX data area on the tape.
	ext-L		TC/UB enables TUG/UBG values to be recorded. The time code generator and the user bits generator lock to the time data input from the TIME CODE IN connector.
	SDI-V		TC/UB enables TUG/UBG values to be recorded. TUG/UBG values are controlled by VITC time data in the video signal input to the HD SDI INPUT A/B connector.
	SDI-L		TC/UB enables TUG/UBG values to be recorded. TUG/UBG values are controlled by LTC time data in the video signal input to the HD SDI INPUT A/B connector.
auto			“regene/int-L” is set in assemble or insert mode and “prst” is set in other modes.

1) The DF/NDF setting on the **[F9]** button is applied to the time code only when “prst” is specified by the **[F7]** button; the DF/NDF setting is always applied for the CTL timer.

2) Specify the signal to be regenerated with the VTR SETUP menu item 608 “TCG/UBG REGENE MODE”. Signals not specified by this menu item are automatically set to Preset mode, regardless of the **[F7]** button setting.

Setting time codes

To set time codes, select “prst” with the **[F7]** (TCG MODE) button in the TC menu and then follow the steps below.

Notes

- Set the **[F8]** (RUN MODE) button to “rec” before setting the time data for recording. When you select “rec”, time data advances from a set value only during recording. When you select “free”, time code advances in real time after the initial value has been set.
- During recording, VITC is always written to the AUX data area of the video signal.

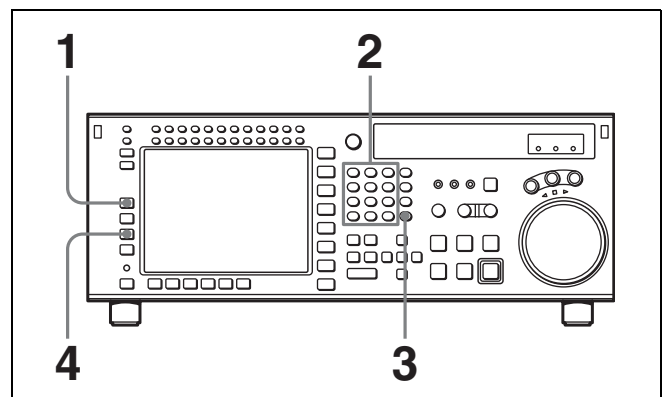

- 1 Press the **[F1]** (TIMER SEL) button to select the TC (time code) to be set.
- 2 Enter the new setting in the data entry window with the numeric buttons.

For example, to enter 01H00M30S00F, press 1, 0, 0, 3, 0, 0, 0. (The leading 0 is not required. When the entered value is less than eight digits, the leading digit(s) is (are) set to 0 when you press the SET button.)

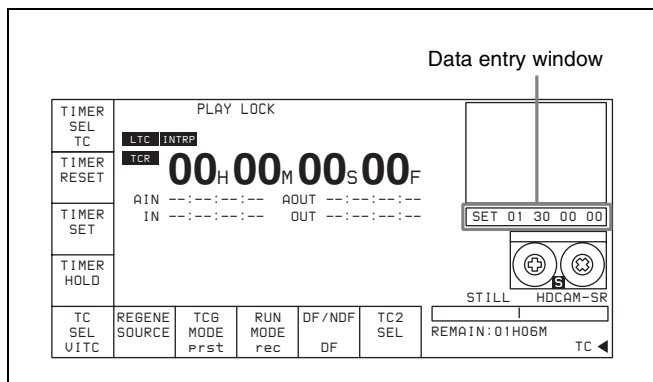

To cancel entered values
Press the CLR button.

3 Press the SET UP button to set the entered value.

If you pressed the + or – button, then entered a value, the result of calculation appears in the display.

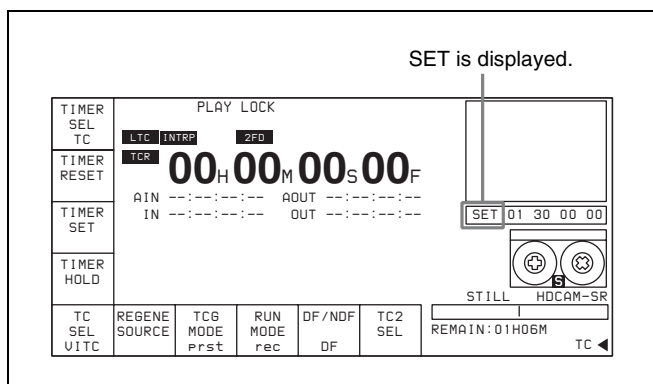

4 Press the **[F3]** (TIMER SET) button.

The input value is set as the time code.

Notes

- Time codes from an external time code generator cannot be set.
- Time codes cannot be set when the internal time code generator is locked to external time codes or to time codes read by the time code reader.

Setting the CTL timer

- 1** Press the **[F1]** (TIMER SEL) button to select CTL.
- 2** Enter data in the data entry window using the numeric buttons.
- 3** Press the SET button to set the data.
- 4** Press the **[F3]** (TIMER SET) button.

Note

When $\pm 12H$ is selected in the VTR SETUP menu item 605 “TAPE TIMER DISPLAY” and a value of 10H or more is entered, the first digit will be dropped.

Resetting time data

Press the **[F2]** (TIMER RESET) button.

The internal time code generator is reset according to the setting of the **[F1]** (TIMER SEL) button.

Resetting TC or UBIT data

The internal time code generator is reset and the time data display becomes 00H00M00S00F (TC) or 00 00 00 00 (UBIT). Edit points are not affected.

Notes

- Time data read by the time code reader cannot be reset.
- Time data cannot be reset when the internal time code generator is locked to external time codes or to time codes read by the time code reader.

Setting the user bit value

1 Press the **[F1]** (TIMER SEL) button to select UBIT.

2 Enter the desired user bit value in hexadecimal notation using the numeric buttons.

Press the 0 to 5 buttons while holding down the SFT button to enter the letters A to F.

3 Press the **[F3]** (TIMER SET) button.

Recording the current time

1 Press the **[F9]** (DF/NDF) button to select “DF”.

2 Press the **[F8]** (RUN MODE) button to select “free”.

3 Enter the target time with the numeric buttons while verifying the data in the data entry window.

4 When the target time arrives, press the **[F3]** (TIMER SET) button.

The time code generator starts operating from the specified time.

To pause the current time

Press the **[F4]** (TIMER HOLD) button.

The time is paused only while the button is held down.

4-3-2 Setting the Time Code Reader (TCR SEL)

Press the **[F5]** (TCR SEL) button to select the time code to be read by the time code reader during playback.

VITC: Reads VITC.

auto: Reads VITC when the playback speed is $\pm 1/2$ times normal speed or less, and LTC when it is greater than $\pm 1/2$ times normal speed.

LTC: Reads LTC.

Depending on the time code recorded on a tape, VITC or LTC appears on the display.

Note

Time codes that are read by the time code reader or played back are output from the TIME CODE OUT connector.

4-3-3 Setting the Time Code Generator (TCG SOURCE/MODE)

There are two ways to record time codes on the VTR. One way is to record the output of the VTR's internal time code generator. The other is to directly record time codes that are input from an external time code generator.

The output from the internal time code generator can either be set to a specified initial value, or synchronized with an external time code generator.

The internal time code generator time code settings are made with the **[F6]** (REGENE SOURCE)/**[F7]** (TCG MODE) buttons. Menu selections and settings are shown in the following table.

Menu TCG	[F6] (REGENE SOURCE)	[F7] (TCG MODE)	Setting
Internal TCG (Preset)		prst	Time codes can be freely set using the internal time code generator
Internal TCG (Regenerate)	int-LTC	regene	Lock to the time data recorded on the time code tracks
	int-VITC	regene	Lock to the time data recorded as video AUX data on the tape
	ext-LTC	regene	Lock to the time data on the TIME CODE IN connector
	SDI-V	regene	Lock to the VITC time data in the video signal from the HD SDI INPUT A/B connector
	SDI-L	regene	
auto			"int-LTC/regene" is set in assemble or insert mode and "prst" is set in other modes

Note

Regenerated signals are selected using the VTR SETUP menu item 608 "TCG/UBG REGENE MODE setting".

To check the running of the internal time code generator

Press the INPUT CHECK button.

4-3-4 Selecting the Time Code Running Mode (RUN MODE)

Press the **[F8]** (RUN MODE) button to select the time code running mode.

free: The time code advances when the power is on regardless of the VTR's operation mode.

rec: The time code advances only during recording.

4-3-5 Selecting the Drop Frame Mode (DF/NDF)

Press the **[F9]** (DF/NDF) button to select the running mode for the CTL counter and the time code generator.

DF: Drop frame mode¹⁾ (DF is displayed.)

NDF: Non-drop frame mode²⁾ (NDF is displayed.)

auto: The unit switches to drop frame mode when the field frequency is 29.97 Hz, and switches to non-drop frame mode when the field frequency is 30 Hz.

1) Drop frame mode

In order to compensate for differences between time code values from the time code generator and the actual time that occurs when the frame frequency of this unit is 29.97 Hz, the drop frame mode causes the time code generator to omit the first two frames (frame 00 and 01) in each minute except the tenth.

2) Non-drop frame mode

In this mode, drop frame mode processing is not performed. Since there is no frame cutting, a discrepancy of about 86 seconds occurs each day in the case of a frame frequency of 29.97 Hz.

Notes

- This setting is only active when the frame frequency of the unit is 29.97 Hz or 30 Hz.
- When the **[F7]** (TCG MODE) button is set to “regene”, the drop frame mode is inoperative since the time code generator is synchronized to the playback time code.

4-3-6 Selecting the Content of the Second Time Code Display Area (TC2 SEL)

Select the content of the second time code display area using the **[F10]** (TC2 SEL) button.

Setting	Time data displayed
OFF	No display
LTC	LTC value read from the time code reader
Auto	When the playback speed is within the range $\pm 1/2$ normal speed, then VITC, and if outside this range then the LTC is displayed.
VITC	VITC value read from the time code reader
CTL	CTL signal count value
UBR	User bits read by the time code reader (LTC)
UBV	User bit value read from the time code reader (VITC)
TCG	Value generated by the time code generator
UBG	User bits value generated by the time code generator

When the two-unit editing display, a warning, or similar is shown, the second time code display area does not appear.

For details about the warnings, see “Warning Messages” on page 136.

4-3-7 Selecting CTL Display Mode (TAPE TIMER)

Press the ALT/**[F1]** (TAPE TIMER) buttons to select a 12-hour or 24-hour clock for the CTL display.

+ -12H: 12-hour clock

24H: 24-hour clock

4-3-8 Presetting Pulldown Time Code (PDPSET MENU) (when HKSR-5001 is installed)

To preset the pulldown time code when this VTR is operated in 23.98PsF/24PsF mode, use the following procedure.

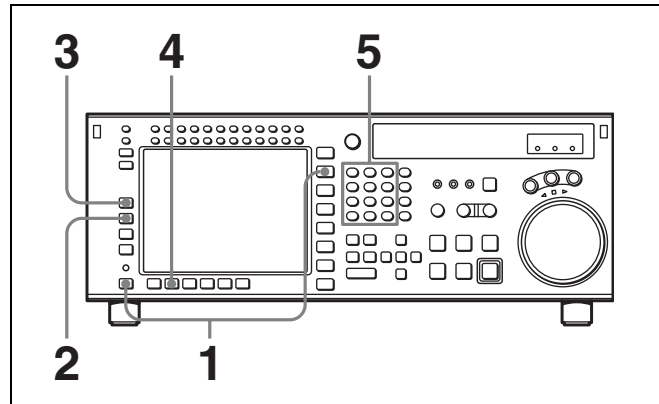

1 Press the TC button, then press the ALT button.

You can also press the ALT and TC buttons simultaneously.

2 Press the **[F2]** (PDPSET MENU) button.

The PDPSET menu appears.

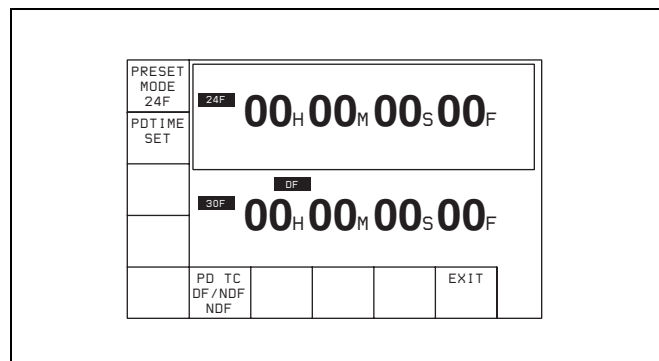

3 Press the **[F1]** (PRESET MODE) button to select 24F or 30F time code to be preset.

The selected time code is framed with the thick line. Each press of the button switches time code between 24F and 30F.

24F: Presets the 24 frames time code. The A frame of the pulldown sequence is preset.

30F: Presets the 30 frames time code. The A frame of the pulldown sequence is preset.

4 • When 30F is selected in the step 3:

Press the **[F6]** (PDTC DF/NDF) button to select DF or NDF.

This selection is effective only for 30F time code.

DF: Drop frame mode

NDF: Non-drop frame mode

auto: The unit switches the running mode (DF/NDF) automatically according to the frame frequency of the unit. When the frame frequency is 23.98 Hz, the unit switches to the drop frame mode and switches to the non-drop frame mode when it is 24 Hz.

• When 24F is selected in the step 3:

Skip this step.

5 Enter the time code data in the data entry window with numeric buttons.

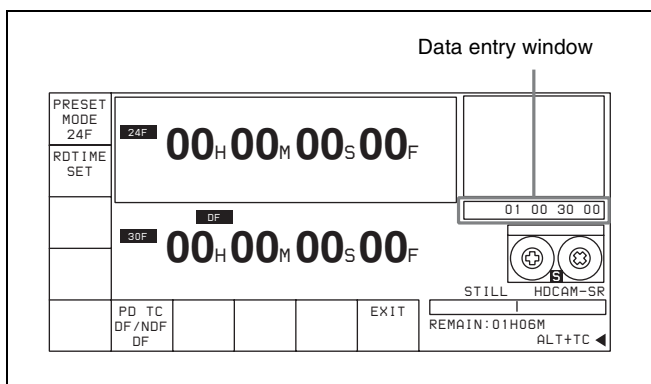

6 Press the SET button to set the input data.

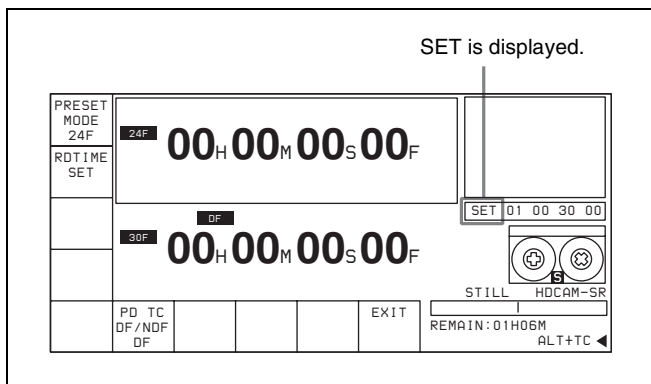

7 Press the **[F2]** (PDTIME SET) button.

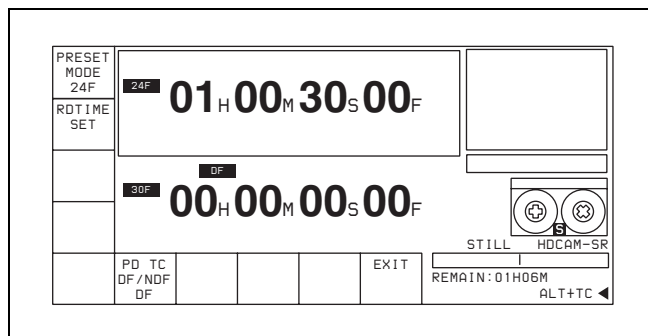

Notes

- Once the time code is preset, it cannot be reverted.
- Operation information display cannot be displayed while the pulldown time code appears.
- The pulldown time code cannot be displayed while the machine-to-machine editing display appears.

4-3-9 Presetting for Conversion from Frame Time Code (TCCONV MENU)

Use the following procedure to set the time code conversion settings.

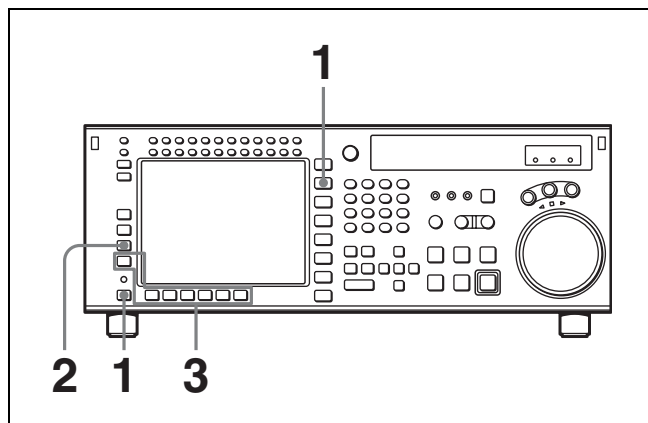

1 Press the TC button, and then press the ALT button.

The ALT+TC menu appears.

2 Press the **[F3]** (TCCONV MENU) button.

The TC CONVERT menu appears.

	STARTING TC 00 ^H 00 ^M 00 ^S 00 ^F				
	JUMPING TC 03 ^H 00 ^M 00 ^S 00 ^F				
TC CONVERSION	CURRENT TC 00 ^H 00 ^M 00 ^S 00 ^F				
ORG TC DISPLAY	START TC PST	START TC ENT	JUMP TC SEL +3H		EXIT

STARTING TC: Time code used as a reference when converting time code.

JUMPING TC: The loopback point for converting time code with STARTING TC as the reference point, and the conversion done in both forward and reverse directions.

The time code is discontinuous at this point.

The following table shows an example of how the 25 frame time code is discontinuous when the operating frequency is 25PsF, the playback tape is 24 frames, and STARTING TC is 01:00:00:00, and 24F JUMPING TC 22:00:00:00 (JUMP TC SEL=-3H).

	24 Frames TC	25 Frames TC	
JUMPING TC	22:00:00:00	20:09:36:00	
	:	:	
	01:00:01:01	01:00:01:00	
Forward direction	01:00:01:00	01:00:00:24	
	:	:	
↑			
STARTING TC	01:00:00:00	01:00:00:00	
↓			
Reverse direction			
	22:00:00:01	22:07:12:01	Non-consecutive part
JUMPING TC	22:00:00:00	21:09:36:00	

3 If necessary, use the function buttons to change the settings.

For details on the settings made by these buttons, see the following table.

Button	Indication	Function
[F3]	TC CONV	Specifies whether the time code is converted to time code or not.
[F4]	ORG TC DISP	Specifies whether the time code is displayed or not on two lines in the HOME, TC, and PF menus along with the converted time code.
[F6]	START TC PST	Press to preset the STARTING TC using the numeric buttons.

Button	Indication	Function
[F7]	START TC ENT	Press to enter the current time code as the STARTING TC.
[F8]	JUMP TC SEL	Selects the JUMPING TC as an interval from STARTING TC. Selectable values: -3H, -2H, -1H, +1H, +2H, +3H, 0H
[F10]	EXIT	Select to exit the TC CONVERT menu.

To preset the 24F STARTING TC using the numeric buttons

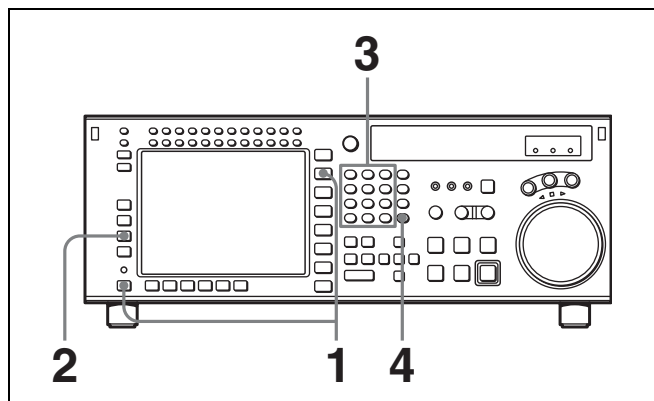

- 1 Press the TC button, and then press the ALT button. The ALT+TC menu appears.
- 2 Press the [F3] (TCCONV MENU) button. The TC CONVERT menu appears.
- 3 Enter the time code in the data entry window with the numeric buttons.

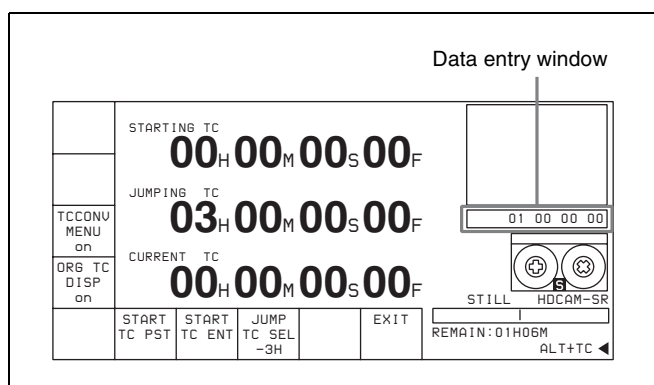

- 4 Press the SET button to set the time code.

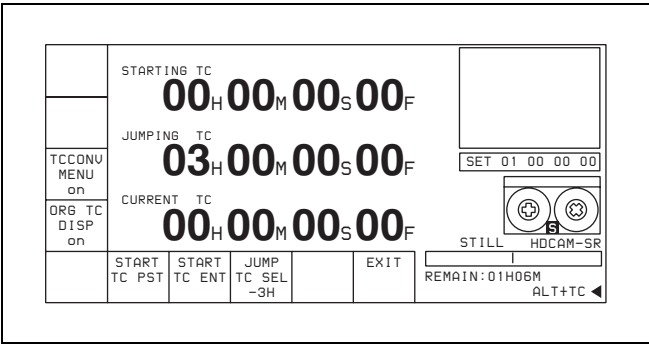

4-3-10 Displaying the Pulldown Time Code (PDTC DISP) (when HKSR-5001 is installed)

To display the pulldown time code, follow the steps below.

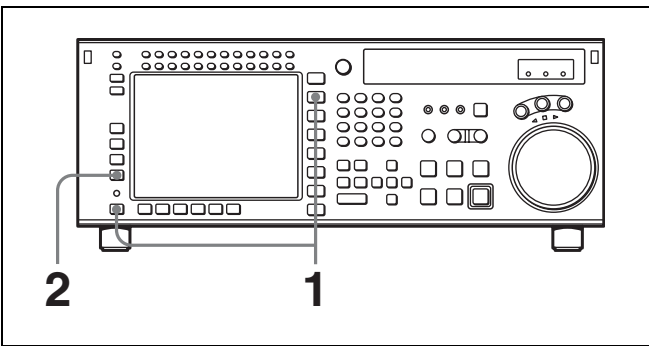

- 1** Press the TC button, then press the ALT button.
The ALT+TC menu appears.
- 2** Press the [F4] (PDTC DISP) button to select (highlight) “on”.
Each time you press the button, “on” and “off” alternate.
on: Displays the pulldown time code.
off: Does not display the pulldown time code.

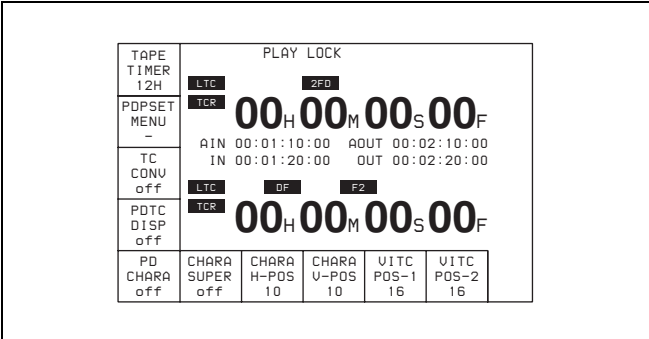

4-3-11 Superimposition of Character Information (PD CHARA/CHARA SUPER/H-POS/V-POS)

To superimpose the characters representing time code data and operation mode information on the output signals, use the ALT/[F4] (PD CHARA) and ALT/[F6] (CHARA SUPER) buttons.

Button	Setting	Connector to which the characters are superimposed
ALT/[F4]	on	FORMAT CONV. OUT connector (on two connectors)
ALT/[F6]	on	<ul style="list-style-type: none"> • MONITOR connector of HD SDI OUTPUT • SD OUT COMPOSITE (MONITOR) connector • MONITOR connector of SD SDI OUT

Contents of superimposed data

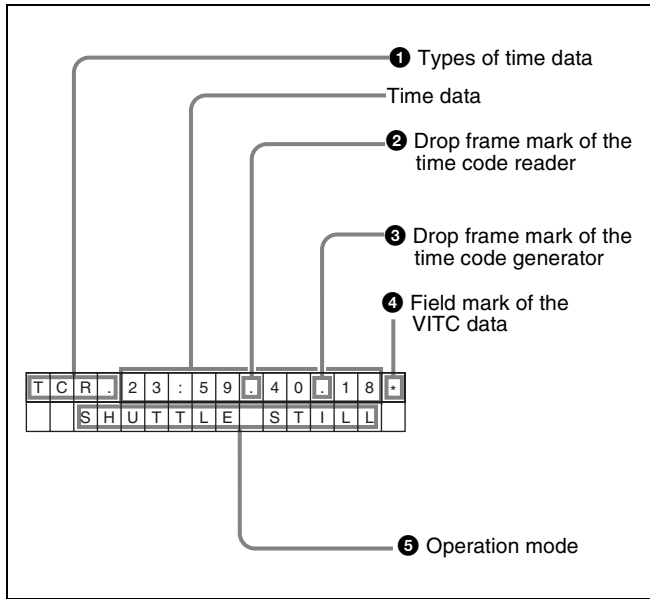

Note

The example above shows the factory-set contents of data. By changing the setting of the VTR SETUP menu item 626 “DISPLAY INFORMATION select”, different types of information can also be displayed on the second line.

1 Types of time data

Symbol	Meaning
CTL	CTL counter data
TCR	LTC reader time code data
UBR	LTC reader user bit data
TCR.	VITC reader time code data

Symbol	Meaning
UBR.	VITC reader user bit data
TCG	Time code data from the time code generator
UBG	User bit data from the time code generator
DUR	The duration between any two of the four edit points (IN, OUT, AUDIO IN, and AUDIO OUT)

Note

When time data or user bits are not read correctly, a “*” will be displayed in this block so that the symbols become “T*R”, “U*R”, “T*R.”, “U*R.”, etc.

② Drop frame mark of the time code reader

“•”: drop frame mode

“:”: non-drop frame mode

③ Drop frame mark of the time code generator

“•”: drop frame mode

“:”: non-drop frame mode

④ Field mark of the VITC data

“ ”: (blank space) fields 1 and 3

“*”: fields 2 and 4

⑤ Operation mode

The contents are divided into blocks A and B as shown below.

Block A: Indicates the operation mode.

Block B: Indicates the tape speed or servo lock status.

Block C: A ■ mark here indicates an edit section for automatic editing.

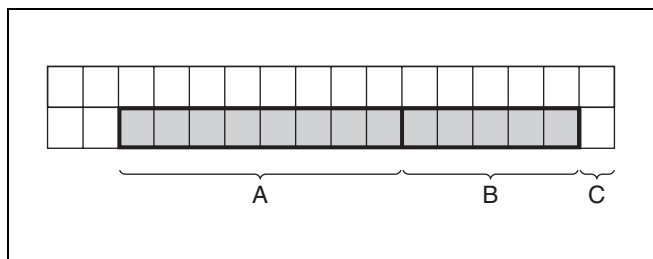

Display		Operation mode
A block	B block	
TAPE UNTHREAD		Cassette not inserted
STANDBY OFF		Standby off mode
T.RELEASE		Tension release mode
STOP		Stop mode
PREROLL		Preroll mode
PLAY		Playback mode (servo unlocked)
PLAY	LOCK	Playback mode (servo locked)
PLY-SPD	Speed shift from normal speed (%)	Capstan override mode
REC		Record mode (servo unlocked)
REC	LOCK	Record mode (servo locked)
EDIT		Edit mode (servo unlocked)
EDIT	LOCK	Edit mode (servo locked)
JOG	STILL	Still-picture jog mode
JOG	FWD	Forward jog (▶ is lit)
JOG	REV	Reverse jog (◀ is lit)
SHUTTLE	(speed)	Shuttle mode
VAR	(speed)	Variable mode
DMC	(speed ^{a)})	DMC memorize mode
D-PREV	(speed ^{a)})	DMC edit preview mode
DMC EDIT		DMC edit mode
DMC-SPD	(speed)	DMC initial speed setting
PREVIEW		Preview mode
AUTO EDIT		Auto edit mode
REVIEW		Review mode

a) Initial speed or memorized speed

To display a warning message

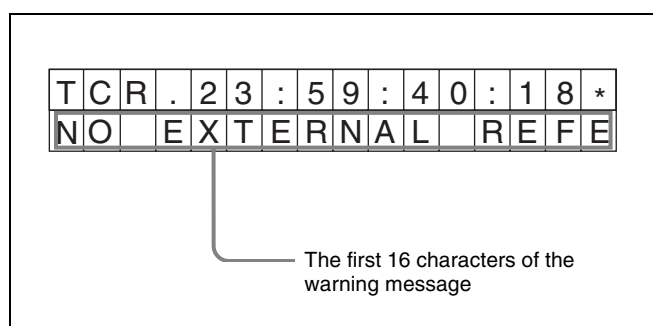

Set the VTR SETUP menu item 626 “DISPLAY INFORMATION select” to any setting other than “time data only” and set the menu item 627 “CHAR WARNING DISPLAY at dual line mode” to “on”. The first 16 characters of the warning message flashes on the second line.

For details about the warning messages, see “Warning Messages” on page 136.

When there are multiple warning messages, each message flashes twice before it is replaced by the next message. When there is no warning message, the setting of the VTR SETUP menu item 626 “DISPLAY INFORMATION select” flashes on the second line instead.

To display remaining time on the tape

Use the VTR SETUP menu item 628 “REMAIN TIME DISPLAY” to display remaining time on the tape.

off: Do not display remaining time.

10min: Display remaining time when it is 10 minutes or less.

on: Always display remaining time.

When remaining time is 23 minutes.

T C R . 2 3 : 5 9 : 4 0 : 1 8 * R 2 3

When remaining time is five minutes.

T C R . 2 3 : 5 9 : 4 0 : 1 8 * R 5

When remaining time to is 100 minutes or over.

T C R . 2 3 : 5 9 : 4 0 : 1 8 * R - -

Changing the superimpose position

The superimpose position can be set to 16 different positions in the horizontal directions (0 to 15) and 24 different positions in the vertical directions (0 to 23).

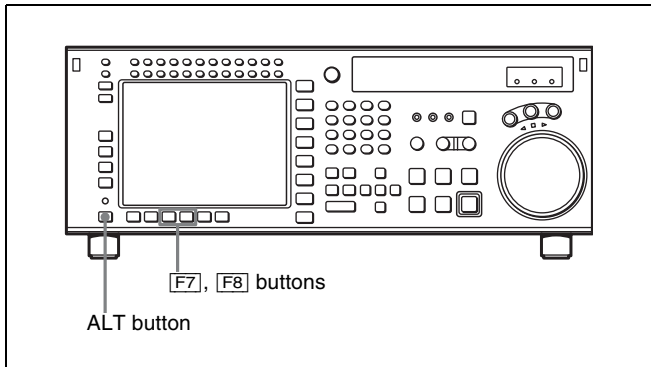

To move in the horizontal direction, press the ALT/**F7**(CHARA H-POS) buttons, and to move in the vertical direction, press the ALT/**F8** (CHARA V-POS) buttons. Each cursor button press increments the setting by 1. From the maximum value, the next value is the minimum value.

Switching to a menu screen other than the TC menu screen also ends the setting.

4-4 CUE Menu

Cue points can be registered in a total of 10 pages (numbered 0 to 9), to a total of 100 cue points (numbered 0 to 99). Each page can hold a maximum of 10 cue points. Cue point settings, deletions, and page settings are done through the CUE menu.

For details on storing cue point data, see “4-1-5 “Memory Stick” Operations” on page 42.

To activate the CUE menu
Press the CUE button.

Note

Cue point data is factory set to be erased when a cassette is inserted.

To select whether to erase cue point data when a cassette is inserted

Press the [F10] (M-CUE CLEAR) button to select whether to erase cue point data when a cassette is inserted.

- on:** Erase cue point data.
- off:** Do not erase cue point data.

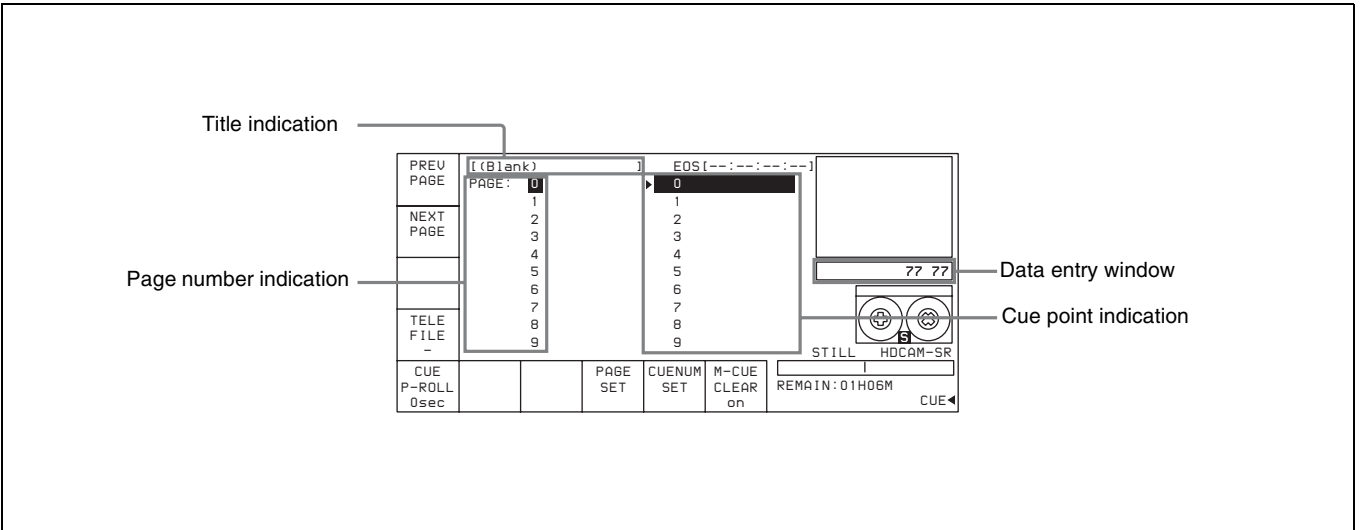

Button	Indication	Function	Settings
[F1]	PREV PAGE	Shows the previous page.	
[F2]	NEXT PAGE	Shows the next page.	
[F4]	TELE FILE	Opens the TELE FILE menu.	
[F5]	CUE P-ROLL	Specifies the preroll time to a cue point.	0 to 30 s
[F8]	PAGE SET	Specifies the page number.	
[F9]	CUENUM SET	Specifies the cue number.	
[F10]	M-CUE CLEAR	Erases cue point data when a cassette is inserted.	on, off
ALT/[F8]	PAGE MODE	Selects PAGE mode.	
ALT/[F9]	EXTEND MODE	Selects EXTEND mode.	

4-4-1 Selecting a Multi-Cue Mode

The SRW-5000/5500 has the following two multi-cue modes.

PAGE mode

Press the ALT/[F8] (PAGE MODE) buttons. In PAGE mode, cue point data can be accessed by page number, thus speeding up cue point registration and cuing operations.

Display

Cue points are displayed in groups of 10, number 0 to 9, 10 to 19, etc. Each display is a page.

Selecting a page

There are the three following ways to select a page:

- Press the [F1] (PREV PAGE) button.
The previous page is shown.
- Press the [F2] (NEXT PAGE) button.
The next page is shown.
- Enter the desired page number with the numeric button, then press the [F8] (PAGE SET) button.
If you enter 1, for example, page one appears, containing cue point numbers 10 to 19.

EXTEND mode

Press the ALT/[F9] (EXTEND MODE) buttons. In EXTEND mode, you can do operations that cannot be done in page units, such as the consecutive registration of more than 10 cue points.

Display

The screen displays a list of 100 consecutive cue points which can be scrolled. Press the ↑ or ↓ button to scroll the list. Page columns are not displayed.

To quickly scroll through a list

Press the ↑ or ↓ button while holding down the SFT button.

4-4-2 Registering Cue Points

There are two ways to register cue points: (1) by direct registration of the tape address when the ENTRY button is pressed, and (2) by the entry of cue point data with the numeric buttons.

Registering cue points by pressing the ENTRY button

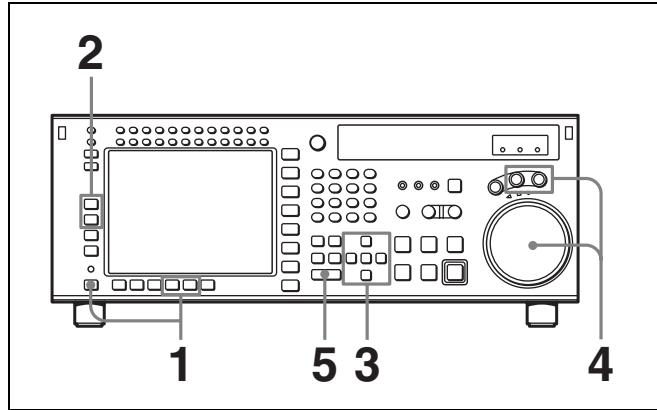

- 1 Press the ALT/[F8] (PAGE MODE) buttons or the ALT/[F9] (EXTEND MODE) buttons.
- 2 If you selected PAGE mode, press the [F1] (PREV PAGE) button or [F2] (NEXT PAGE) button to select a desired page (or use the numeric buttons to enter the page number in the data entry window, then press the [F8] (PAGE SET) button).
- 3 Press the ↑ or ↓ button to move the cursor (▶) to the cue number to be registered.

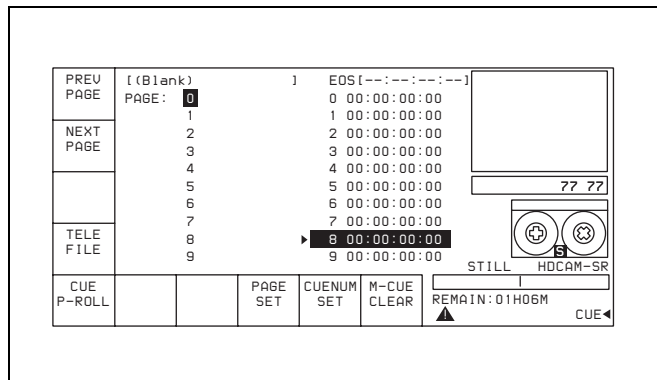

To select the cue number directly by numeric buttons

Enter the cue number in the data entry window with the numeric buttons, then press the [F9] (CUENUM SET) button.

- 4 Press the JOG or VAR button, then rotate the MULTI CONTROL knob to find the position where you want to register the cue point.
- 5 Press the ENTRY button at the selected position.

The current tape address of the position where the button is pressed is registered as a cue point. Press the ENTRY button repeatedly to register the cue point repeatedly. The cue number will automatically increment by one each time.

PREV PAGE	[(Blank)]	EOS[---:---:---]	
PAGE	0	0 00:01:10:00	
NEXT PAGE	1	1 00:02:10:00	
	2	2 00:03:10:00	
	3	3 00:04:10:00	
	4	4 00:05:10:00	?? ??
	5	5 00:06:10:00	
	6	6 00:07:10:00	
	7	7 00:08:10:00	
TELE FILE	8	8 00:09:10:00	
	9	9 00:10:10:00	
CUE P-ROLL		PAGE SET	CUENUM SET
		M-CUE CLEAR	REMAIN:01H06M
			STILL HD-CAM-SR
			▲ CUE◀

Note

In PAGE mode, the cue number advances only within the current page when the ENTRY button is pressed repeatedly. For example, after cue number 19 is registered and the ENTRY button is pressed, the cue point 10 comes up as the next cue point. In EXTEND mode, if you press the ENTRY button after registering, for example, cue number 99, the next cue point is registered to cue number 99 again.

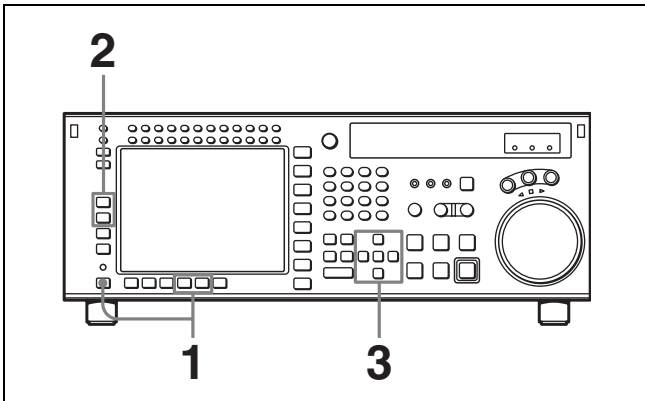
Registering cue points by the numeric buttons

- 1 Press the ALT/[F8] (PAGE MODE) buttons or the ALT/[F9] (EXTEND MODE) buttons.
- 2 If you selected PAGE mode, press the [F1] (PREV PAGE) button or [F2] (NEXT PAGE) button to select a desired page (or use the numeric buttons to enter the page number in the data entry window, then press the [F8] (PAGE SET) button).
- 3 Press the cursor \uparrow or \downarrow button to move the cursor (▶) to the cue number to be registered.

PREV PAGE	[(Blank)]	EOS[---:---:---]	
PAGE	0	0 00:01:10:00	
NEXT PAGE	1	1 00:02:10:00	
	2	2 00:03:10:00	
	3	3 00:04:10:00	
	4	4 00:05:10:00	?? ??
	5	5 00:06:10:00	
	6	6 00:07:10:00	
	7	7 00:08:10:00	
TELE FILE	8	8 00:09:10:00	
	9	9 00:10:10:00	
CUE P-ROLL		PAGE SET	CUENUM SET
		M-CUE CLEAR	REMAIN:01H06M
			STILL HD-CAM-SR
			▲ CUE◀

To select the cue number directly by the numeric buttons

Enter the cue number in the data entry window with the numeric buttons, then press the [F9] (CUENUM SET) button.

- 4 Enter the cue point data in the data entry window with the numeric buttons, then press the SET button.

For example, to enter 00:01:30:00, press 0, 0, 1, 3, 0, 0. (The leading 0 is not required. When the entered value is less than eight digits, the leading digit(s) (are) set to 0 when you press the SET button.)

Entered data			
PREV PAGE	[(Blank)]	EOS[00:13:00:00]	
PAGE	0	10 00:10:00:00	
NEXT PAGE	1	11 00:11:00:00	
	2	12 00:12:00:00	
	3	13 00:13:00:00	
	4	14 00:14:00:00	SET-00 13 00 00
	5	15 00:15:00:00	
	6	16 00:16:00:00	
	7	17 00:17:00:00	
TELE FILE	8	18 00:18:00:00	
	9	19 00:19:00:00	
CUE P-ROLL		PAGE SET	CUENUM SET
		M-CUE CLEAR	REMAIN:01H06M
			STILL HD-CAM-SR
			▲ CUE◀

To modify current cue point data

Press the + or – button, enter the value to be added or subtracted, then press the SET button.

The computation is performed and the results appear in the data entry window.

- 5 Press the ENTRY button to set the entered data.

The data are registered in the cue point data indication.

PREV PAGE	[(Blank)	1	EOS[00:13:00:00]	
	PAGE:	0	10 00:10:00:00	
NEXT PAGE		1	11 00:11:00:00	
		2	12 00:12:00:00	
		3	13 00:13:00:00	
		4	14 00:14:00:00	
		5	15 00:15:00:00	
		6	16 00:16:00:00	
		7	17 00:17:00:00	
TELE FILE		8	18 00:18:00:00	
		9	19 00:19:00:00	
CUE P-ROLL		PAGE SET	CUENUM SET	M-CUE CLEAR
			REMAIN:01H06M	CUE◀

4-4-3 Erasing Cue Point Data

To erase any cue point data, blank out the data entry window, then do the cue point registration procedure.

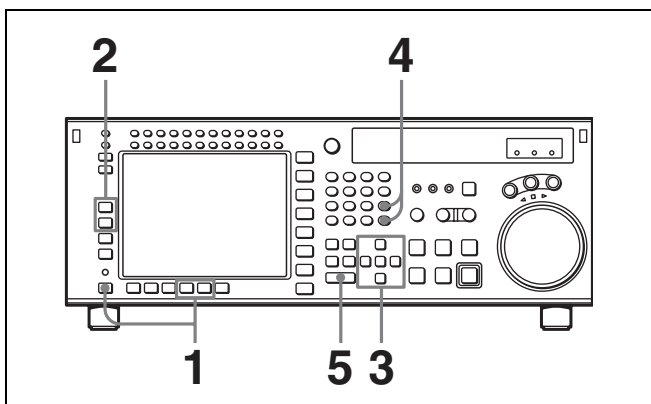

- 1 Press the ALT/[F8] (PAGE MODE) buttons or the ALT/[F9] (EXTEND MODE) buttons.
- 2 If you selected PAGE mode, press the [F1] (PREV PAGE) button or [F2] (NEXT PAGE) button to select a desired page (or use the numeric buttons to enter the page number in the data entry window, then press the [F8] (PAGE SET) button).
- 3 Press the cursor ↑ or ↓ button to move the cursor (▶) to the cue number to be erased.

PREV PAGE	[(Blank)	1	EOS[00:13:00:00]	
	PAGE:	0	10 00:10:00:00	
NEXT PAGE		1	11 00:11:00:00	
		2	12 00:12:00:00	
		3	13 00:13:00:00	
		4	14 00:14:00:00	
		5	15 00:15:00:00	SET-01 15 00 00
		6	16 00:16:00:00	
		7	17 00:17:00:00	
TELE FILE		8	18 00:18:00:00	
		9	19 00:19:00:00	
CUE P-ROLL		PAGE SET	CUENUM SET	M-CUE CLEAR
			REMAIN:01H06M	CUE◀

To select the cue number directly by the numeric buttons

Enter the cue number in the data entry window with the numeric buttons, then press the [F9] (CUENUM SET) button.

- 4 Press the CLR button then press the SET button.

The cue point display disappears from the data entry window.

Data entry window				
PREV PAGE	[(Blank)	1	EOS[00:13:00:00]	
	PAGE:	0	10 00:10:00:00	
NEXT PAGE		1	11 00:11:00:00	
		2	12 00:12:00:00	
		3	13 00:13:00:00	
		4	14 00:14:00:00	
		5	15 00:15:00:00	SET
		6	16 00:16:00:00	
		7	17 00:17:00:00	
TELE FILE		8	18 00:18:00:00	
		9	19 00:19:00:00	
CUE P-ROLL		PAGE SET	CUENUM SET	M-CUE CLEAR
			REMAIN:01H06M	CUE◀

- 5 Press the ENTRY button.

Data for the specified cue number are erased and the data column becomes blank.

Erased cue point				
PREV PAGE	[(Blank)	1	EOS[00:13:00:00]	
	PAGE:	0	10 00:10:00:00	
NEXT PAGE		1	11 00:11:00:00	
		2	12 00:12:00:00	
		3	13 00:13:00:00	
		4	14 00:14:00:00	
		5	15 00:15:00:00	
		6	16 00:16:00:00	
		7	17 00:17:00:00	
TELE FILE		8	18 00:18:00:00	
		9	19 00:19:00:00	
CUE P-ROLL		PAGE SET	CUENUM SET	M-CUE CLEAR
			REMAIN:01H06M	CUE◀

To erase all cue point data

Press the CLR button while holding down the SFT button. A message asking you to confirm the operation appears in the display.

In EXTEND mode, press the CLR button while holding down the SFT button again to erase all data for cue number 0 to 99.

In PAGE mode, press the CLR button while holding down the SFT button again to erase data for the cue points on the current page.

4-4-4 Prerolling to a Cue Point

Select the preroll time to a cue point with pressing the [F5] (CUE P-ROLL) button.

You can set a preroll time of 0 to 30 seconds.

Prerolling to a cue point

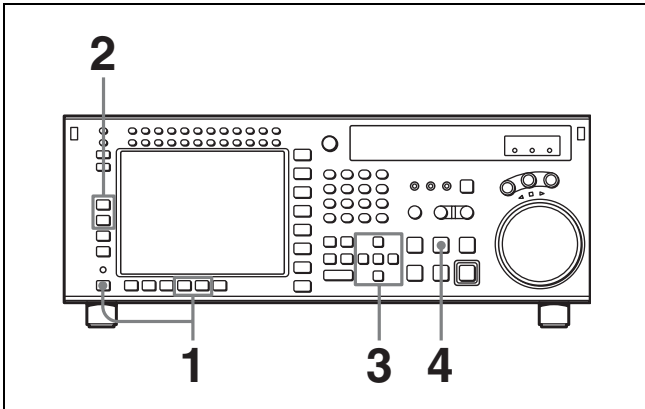

- 1 Press the ALT/[F8] (PAGE MODE) buttons or the ALT/[F9] (EXTEND MODE) buttons.
- 2 If you selected PAGE mode, press the [F1] (PREV PAGE) button or [F2] (NEXT PAGE) button to select a desired page (or use the numeric buttons to enter the page number in the data entry window, then press the [F8] (PAGE SET) button).
- 3 Press the cursor \uparrow or \downarrow button to move the cursor (\blacktriangleright) to the cue number.

To select the cue number directly by the numeric buttons

Enter the cue number in the data entry window with the numeric buttons, then press the [F9] (CUENUM SET) button.

- 4 Press the PREROLL button.

4-4-5 Changing a Cue Point Into an Edit Point

Follow the procedures below to change a selected cue point into an edit point.

To change an edit point into an IN point

Press the SET button while holding down the IN button.

To change an edit point into an OUT point

Press the SET button while holding down the OUT button.

To change an edit point into an AUDIO IN point

Press the SET button while holding down the AUDIO IN button.

To change an edit point into an AUDIO OUT point

Press the SET button while holding down the AUDIO OUT button.

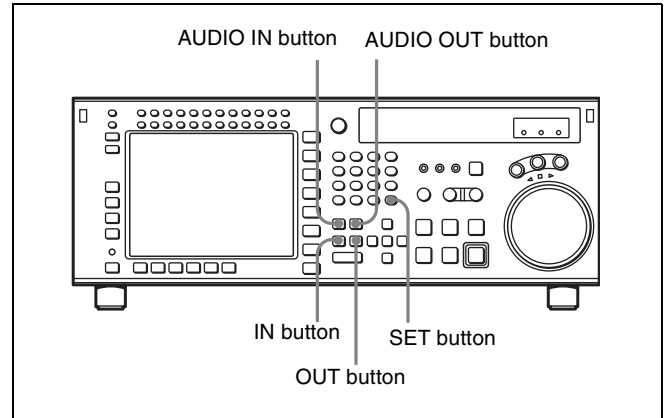

4-4-6 TELE FILE Menu

The TELE FILE menu screen is different in HDCAM-SR and HDCAM formats.

In HDCAM-SR format: The cassette has a memory label attached as standard, and this screen allows operations to read out, enter, or change the cassette ID identification, recording format, recording information, management information, and so on. In the HDCAM-SR format, each recording automatically adds recording information. However, if the recording time is less than 2 seconds, or if when recording ends the measurement on the spool was not complete, then no recording information is added. In the case of an HDCAM-SR cassette, a cassette without a memory label is ejected.

In HDCAM format: When an MLB-1M-100 memory label (optional) is attached to the cassette, this screen allows operations to read out, enter, or change the cue point information, log (IN/OUT point) information, management information, and so on. Using this information, cassette tape management and tape editing efficiency can be improved.

HDCAM-SR format TELE FILE menu

To open the TELE FILE menu

There are two methods of accessing the TELE FILE menu screen, as follows.

- Press the [F4] (TELE FILE) button while in the CUE menu.
- Select “on” for the VTR SETUP menu item 124 “Tele-File MENU auto popup”. Then, with the HOME, TC, VIDEO, AUDIO, CUE, or SETUP menu open, insert a cassette into the VTR.

To change the information displayed in the TELE FILE menu

Press the cursor \leftarrow or \rightarrow button.

Exiting the TELE FILE menu

Press the **[F10]** (WRITE/EXIT) button. The entered or modified data is saved to the memory label and the VTR exits the TELE FILE menu.

Note

While the data is being changed, if the write-protect setting has been made for the whole TELE FILE menu, then data changed before the setting was made is rewritten.

To exit the TELE FILE menu without saving data to a memory label

Press the EJECT button, or press the ALT/**[F2]** (UNDO ALL) buttons. After a window that confirms cancelation is displayed, hold down the SFT button, and press the **[F2]** (UNDO ALL) button. The memory label contents when the cassette was inserted are restored.

If you accidentally press the EJECT button before saving data to a memory label

Insert the cassette again within 30 seconds after the ejection and press the **[F10]** (WRITE/EXIT) button. The data that existed before the ejection of the cassette is saved to the memory label.

Three levels of information can be displayed in the TELE FILE menu and the levels can be scrolled to the left or right by pressing the ← or → button.

CUE SCAN	REC DATE [2003/02/25]	EOS[01:01:24:15]	TITLE [Display Sample]	Rest 87%
ENTRY POINT CUE	No.	IN	OUT	Tape Format
1	00:03:45:21	01:00:36:06	59i 1080	
2	01:04:27:23	01:05:31:24	59i 1080	
3	01:08:11:03	01:09:48:20	60i 720	
4	00:00:00:01	01:00:36:06	23P 1080	
5	00:00:00:01	01:00:36:06	23i 1080	

TELE FILE menu display 1

CUE SCAN	REC DATE [2003/02/25]	EOS[01:01:24:15]	TITLE [Display Sample]	Rest 87%
ENTRY POINT CUE	No.	Tape Format	Duration	Date/Time
1	59i 1080 422	01:00:36:06	-----	
2	59i 1080 422	00:01:25:08	-----	
3	60P 720 422	00:02:36:45	-----	
4	23P 1080 422	01:00:36:06	02/08/08	
5	23P 1080 422	01:00:36:06	02/08/08	

TELE FILE menu display 2

CUE SCAN	REC DATE [2003/02/25]	EOS[01:01:24:15]	TITLE [Display Sample]	Rest 87%
ENTRY POINT CUE	No.	Data/Time	File Name	
1	-----	-----	HDCAMSR_000	
2	-----	-----	HDCAMSR_001	
3	-----	-----	HDCAMSR_002	
4	02/08/08	13:21:09	test	
5	02/08/08	13:24:27	HDCAMSR_011	

TELE FILE menu display 3

1 Tape Format

Displays the recording format.

2 OUT

Displays the recording end point data.

3 IN

Displays the recording start point data.

4 TITLE

Displays the cassette title.

5 REC DATE

Displays the date the memory label contents were last modified.

6 Date/Time

Displays the recording date and time.

7 Duration

Displays the recording duration.

8 File Name

Displays the names of files.

When the TELE FILE menu display 2 is displayed, you can press the SFT button to switch the TAPE FORMAT display between “59i 1080 422” and “59i 4:2:2 SQ”.

Button	Indication	Function
[F1]	CUE SCAN	Specifies the direction of the cursor movement when the PREROLL button is pressed.
[F4]	CHANGE DATA	Modifies the specified data.
[F5]	DEL POINT	Deletes the time data of the cue point.
[F7]	PROTECT	Write-protects the cue point data.
[F8]	TAPE INFO	Displays the information window.
[F9]	CUENUM POINT	Moves the cursor to the line specified by the numeric buttons.

Button	Indication	Function
[F10]	WRITE/EXIT	Closes the TELE FILE menu after saving changes to the memory label.
ALT/[F1]	FORMAT T-Fil	Formats the memory label.
ALT/[F2]	UNDO ALL	Undoes all changes.
ALT/[F3]	ATTRIB EDIT	Changes the ID, ADMIN, or TITLE data in the information window.
ALT/[F4]	COPY to CUE	Copies the time data of a cue point to another cue point indicated in the CUE menu.
ALT/[F7]	WRITE PRTEC	Prohibits TELE FILE menu operations.
ALT/[F10]	WRITE/EXIT	Closes the TELE FILE menu after saving changes to the memory label.

Formatting a memory label

- 1 Press the ALT/[F1] (FORMAT T-Fil) buttons.
- 2 Press the [F1] (FORMAT T-Fil) button while holding down the SFT button.

A message appears (in the control panel display) requesting confirmation of the formatting operation.

To cancel the formatting operation

Press the CLR button.

- 3 Press the [F1] (FORMAT T-Fil) button while holding down the SFT button.

“COMPLETED” appears in the control panel display.

Prohibiting TELE FILE menu operations

Press the ALT/[F7] (WRITE PRTEC) buttons.

on: All TELE FILE menu operations are prohibited.

off: All TELE FILE menu operations are permitted.

Changing a title

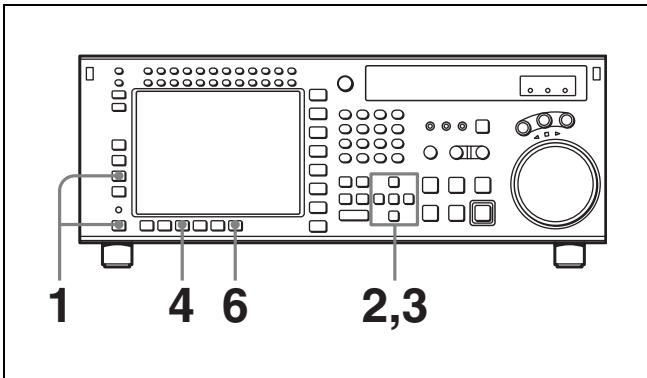

- 1 Press the ALT/[F3] (ATTRIB EDIT) buttons.

- 2 Press the ↑ or ↓ button to select TITLE, and then press the ENTRY button.

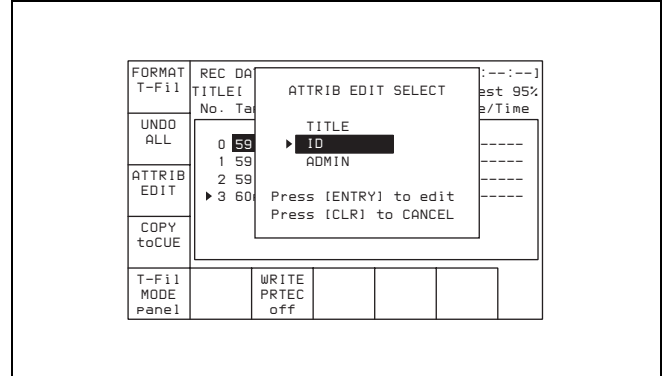

- 3 Press the cursor ← or → button to select a character.

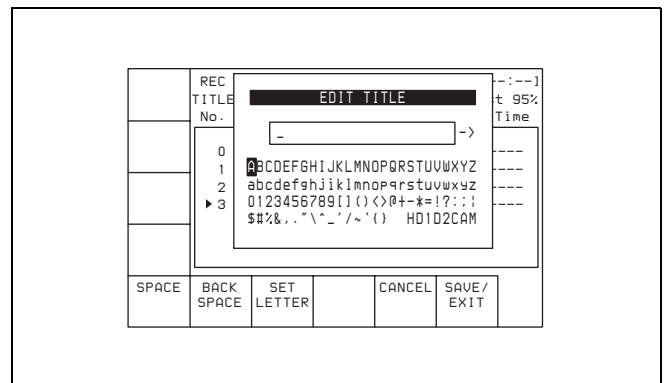

- 4 Press the [F7] (SET LETTER) button or the cursor center button.

The selected character is entered.

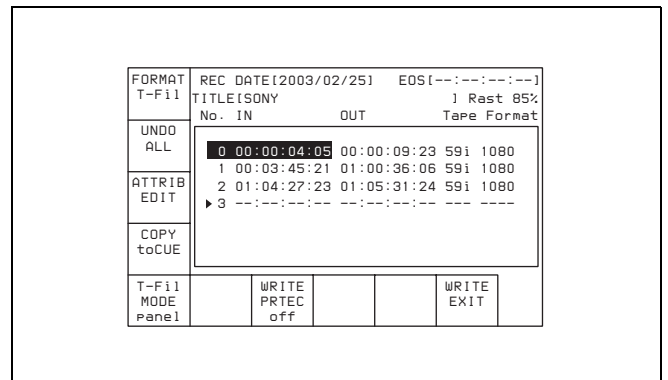

- 5 Repeat steps 3 and 4 to enter more characters.

To enter a space

Press the [F5] (SPACE) button.

If you enter a wrong character

Press the [F6] (BACK SPACE) button to go back. Then re-enter the character.

To start the procedure over again

Press the [F9] (CANCEL) button to start again.

To change a character

Press the cursor \uparrow button to move the cursor to the title box. Then press the cursor \leftarrow or \rightarrow button to change the insertion position.

If entered title exceeds the length of the title box

\blacktriangleleft or \blacktriangleright appears to the left or right of the box.

- 6 Press the $\boxed{F10}$ (SAVE/EXIT) button.

The screen that was on before the title was entered is displayed again.

To change IN/OUT point time data

- 1 Use the cursor buttons to move the cursor (\blacktriangleright) to the line where you want to change IN/OUT point time data.

To move the cursor using the numeric buttons

With the cursor specifying IN or OUT, enter the line number using the numeric buttons. Then press the $\boxed{F9}$ (CUENUM POINT) button. The cursor will move to the line specified by the numeric buttons.

Note

If the cursor (\blacktriangleright) is not linked with the cursor buttons, the cursor (\blacktriangleright) will not move when the cursor buttons are pressed.

To link the cursor (\blacktriangleright) with the cursor buttons

Press the cursor center button. Each press of the button alternately links and unlinks the cursor \blacktriangleright .

- 2 Press the ENTRY button.

When the cursor buttons are aligned with the IN point, and the IN point is at the OUT point, when you press the ENTRY button at the OUT point, the time code is either entered as a new value or updated. To update the data, the winding diameter measurement must be completed, and the drum locked, and then the tape information read in.

Note

If the cursor (\blacktriangleright) is not on the screen when the ENTRY button is pressed, the time data on the line currently specified by the cursor (\blacktriangleright) changes to the current time data, and the line is automatically displayed.

To clear the data

With the cursor buttons, align the cursor with the data you want to clear, and in the case of the IN point hold down the IN button, and in the case of the OUT point hold down the OUT button, and press the CLR button, to clear the data. You can also clear the data by holding down the CLR button, and pressing the IN button or OUT button.

Effect on other data of data entry or update

When you enter or update the IN point or OUT point, other data is updated as shown in the following table.

IN point entry/update:

State of the already-entered data	IN point	OUT point
The already-entered OUT point data and entered or updated IN point data are in the correct time sequence	Data is updated	Data is not updated
The already-entered OUT point data and entered or updated IN point are not in the correct time sequence	Data is updated	Data is deleted
OUT point data has not been entered	Data is updated	Data is not updated

OUT point entry/update:

State of the already-entered data	IN point	OUT point
The already-entered IN point data and entered or updated OUT point data are in the correct time sequence	Data is not updated	Data is updated
The already-entered IN point data and entered or updated OUT point are not in the correct time sequence	Data is not updated	Data is not updated
IN point data has not been entered	Data is not updated	Data is updated

Updating File Name data

To update File Name data, press the cursor \rightarrow button several times.

To update data

- 1 With the cursor buttons, align the cursor with the File Name data you want to update.

To move the cursor with the numeric buttons

Enter a line number with the numeric buttons, and press the $\boxed{F9}$ (CUENUM POINT) button. The cursor moves to the line number you entered.

- 2 Press the $\boxed{F4}$ (CHANGE DATA) button.
- 3 With the cursor \leftarrow or \rightarrow button, select the character to be entered.
- 4 Press the $\boxed{F7}$ (SET LETTER) button or cursor center button.
The selected character is entered.
- 5 Repeat steps 3 and 4, to enter the data.

A maximum of 15 characters can be entered.

Note

If the number of entered characters is too large, a memory overflow may occur, and it may become impossible to enter other cue point data. Press the **[F8]** (TAPE INFO) button to check the free memory capacity.

To enter a space

Press the **[F5]** (SPACE) button, then carry out entry.

If you make an error in entry

Press the **[F6]** (BACK SPACE) button, then carry out entry.

Canceling and repeating the process

Press the **[F9]** (CANCEL) button, then carry out entry.

To change a character during the operation

Press the cursor **↑** button, then move the cursor to the comment frame. With the cursor **←** button or **→** button, change the character insertion position.

- 6 Press the **[F10]** (SAVE/EXIT) button.

This returns to the original menu screen.

Cueing up to the IN point

- 1 Hold down the **[F1]** (CUE SCAN) button, and press the PREROLL button. This sets the cursor movement direction.

Each press cycles through the settings FWD/REW/No setting.

FWD: Pressing the PREROLL button moves the cursor to the next line, and cues up to the time data of that line. Invalid time data is ignored.

REW: Pressing the PREROLL button moves the cursor to the previous line, and cues up to the time data of that line. Invalid time data is ignored.

- 2 Press the PREROLL button.

To write-protect the cue point data

To write-protect individual cue point data items, align the cursor with the line you want to write-protect, then press the **[F7]** (PROTECT) button. When **⚡** appears to the right of “No.”, then it is not possible to change the IN, OUT, and File Name settings.

Canceling the write-protect setting

To cancel the write-protect setting, press the **[F7]** (PROTECT) button. After a confirmation message appears, hold down the SFT button and press the **[F7]** (PROTECT) button.

To insert a new line

- 1 Use the cursor buttons to position the cursor (▶) below the line where a new line will be inserted.

To move the cursor with the numeric buttons

To move the cursor, enter a line number with the numeric buttons, then press the **[F9]** (CUENUM POINT) button. The cursor moves to the line number you entered.

Note

If the cursor buttons are not linked to movement of the entry cursor ▶, it is not possible to move the entry cursor ▶ with the cursor buttons.

To link the cursor buttons to movement of the entry cursor ▶

Press the cursor center button. To unlink, press the cursor center button once again.

- 2 Press the ENTRY button while pressing down the SFT button.

A new line is inserted above the line specified by where the cursor (▶) is placed and the current time data is entered on that line.

To delete a line

To delete a line, with the cursor buttons align the cursor with the line to be deleted, hold down the SFT button, and press the **[F5]** (DEL POINT) button. This deletes the line, and renumbers the lines following the deleted line.

To display other information

To display other information, press the **[F8]** (TAPE INFO) button. This opens a window to display the information.

To close the window

Press the **[F8]** (TAPE INFO) button.

To change the ID/ADMIN data

- 1 Press the ALT/**[F3]** (ATTRIB EDIT) buttons.
- 2 With the cursor **↑** or **↓** button, select “ID” or “ADMIN”, then press the ENTRY button.
- 3 With the cursor **←** or **→** button, select the character to be entered.
- 4 Press the **[F7]** (SET LETTER) button or cursor center button.

The selected character is entered.

- 5 Repeat steps 3 and 4, to enter the data.

To enter a space

Press the **[F5]** (SPACE) button.

If you make an error in entry

Press the **[F6]** (BACK SPACE) button, then carry out entry.

Returning to the original settings

Press the **[F9]** (CANCEL) button, then carry out entry.

To change a character during the operation

Press the cursor **↑** button, then move the cursor to the ID or ADMIN frame. With the cursor **←** or **→** button, change the character insertion position.

When not all characters can be shown within the ID or ADMIN frame

On the left or right of the comment frame, **◀** or **▶** appears.

6 Press the **[F10]** (SAVE/EXIT) button.

This returns to the original screen.

HDCAM format TELE FILE menu

Accessing the TELE FILE menu screen

There are two methods of accessing the TELE FILE menu screen, as follows.

- In the CUE menu screen, press the **[F4]** (TELE FILE) button.
- Set the VTR SETUP menu item 124 “Tele-File MENU auto popup” to “on”, then in the HOME, VIDEO, AUDIO, TC, CUE, or SETUP menu screen, insert a cassette that has an MLB-1M-100 memory label (option) attached.

To scroll the TELE FILE menu screen horizontally

Press the cursor **←** or **→** button.

There are two ways of displaying log (IN/OUT point) data in the TELE FILE menu screen, as follows.

- In the TELE FILE menu screen, press the **[F2]** (ENTRY POINT) button, and select “IN/OUT point”.
- Set the VTR SETUP menu item 126 “Tele-File ENTRY POINT” to “IN/OUT point”.

Note

While the data is being changed, if the write-protect setting has been made for the whole TELE FILE menu, then data changed before the setting was made is rewritten.

To exit the TELE FILE menu without overwriting the changed point(s)

Press the EJECT button, or press the ALT/**[F2]** (UNDO ALL) buttons. After a window that confirms cancelation is displayed, hold down the SFT button, and press the **[F2]** (UNDO ALL) button. The memory label contents when the cassette was inserted are restored.

If you inadvertently press the EJECT button without rewriting the data

Reinsert the ejected cassette within 30 seconds, and press the **[F10]** (WRITE/EXIT) button. This writes the data from immediately before ejection.

The TELE FILE menu screen scrolls in the following four stages. Scroll the screen with the cursor **←** or **→** button.

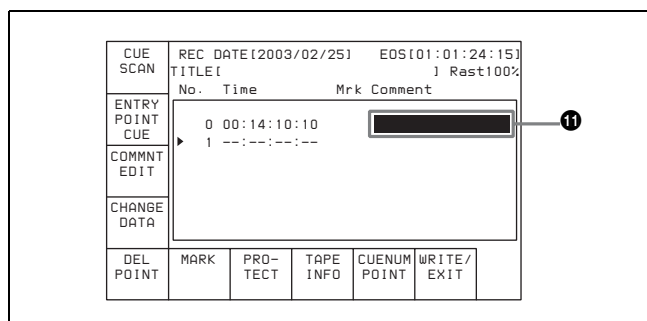
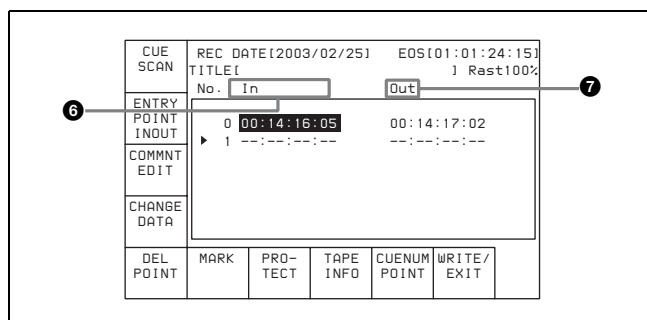
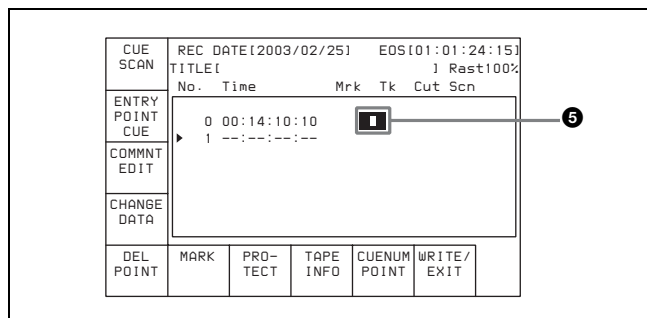
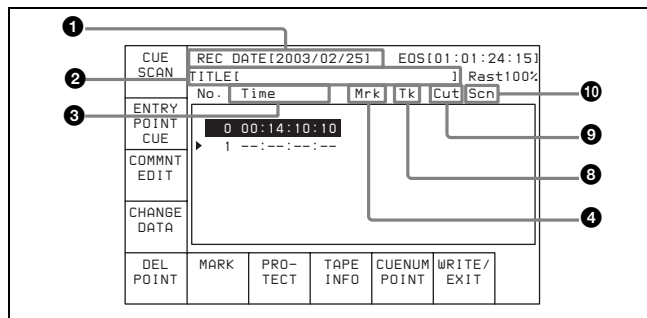

1 REC DATE (recording data date)

Shows the last date of recording.

2 TITLE

Shows the title of the cassette content.

3 Time

Shows the time data of a cue point.

4 Mrk (mark)

Shows an indication of a cue point attribute (OK/NG/KP/blank).

5 Recording start point

When a cue point is the recording start point, shows @.

For how to select “on” or “off” for the recording starting point setting, see “Changing the recording starting point setting” on page 81.

6 IN

Shows log (IN point) data.

7 OUT

Shows log (OUT point) data.

8 Tk (take)

Shows the take number of a cue point.

9 Cut

Shows the cut number of a cue point.

10 Scn (scene)

Shows the scene number of a cue point.

11 Comment

Shows a comment on a cue point.

Button	Indication	Function
[F1]	CUE SCAN	Sets the cursor movement direction when the PREROLL button is pressed.
[F2]	ENTRY POINT	Selects whether or not to display log (IN/OUT point) information.
[F3]	COMMNT EDIT	Edits the Comment box.
[F4]	CHANGE DATA	Changes the value of data.
[F5]	DEL POINT	Deletes time data.
[F6]	MARK	Changes the setting in the Mrk box.
[F7]	PROTECT	Prevents the cue point data from being changed.
[F8]	TAPE INFO	Shows information on the memory label.
[F9]	CUENUM POINT	Moves the cursor to the line number entered with the numeric buttons.
[F10]	WRITE/EXIT	Saves the changes and exits the TELE FILE menu.
ALT/[F1]	FORMAT T-Fil	Formats a memory label.
ALT/[F2]	UNDO ALL	Cancels all changes.
ALT/[F3]	ATTRIB EDIT	Changes the ID, ADMIN, and TITLE within the tape information window.
ALT/[F4]	COPY to CUE	Copies time data to the CUE menu screen cue point data.

Button	Indication	Function
ALT/[F7]	WRITE PRTEC	Sets or unsets write protection of the whole TELE FILE menu.
ALT/[F10]	WRITE/EXIT	Saves the changes and exits the TELE FILE menu.

To format a memory label

1 Press the ALT/[F1] (FORMAT T-Fil) buttons.

2 Hold down the SFT button, and press the [F1] (FORMAT T-Fil) button.

A confirmation window appears.

To cancel

Press the CLR button.

3 Hold down the SFT button, and press the [F1] (FORMAT T-Fil) button.

“COMPLETED” appears.

To set write protection for the whole menu

Press the ALT/[F7] (WRITE PRTEC) buttons.

on: Set write protection for the whole TELE FILE menu.

off: Clear write protection for the whole TELE FILE menu.

To change the TITLE data

1 Press the ALT/[F3] (ATTRIB EDIT) buttons.

2 With the cursor ↑ or ↓ button, select “TITLE”, and press the ENTRY button.

3 With the cursor ← or → button, select the character to be entered.

4 Press the [F7] (SET LETTER) button or cursor center button.

The selected character is entered.

5 Repeat steps **3** and **4**, to enter the data.

To enter a space

Press the [F5] (SPACE) button.

If you make an error in entry

Press the [F6] (BACK SPACE) button, then repeat the entry.

To return to the initial screen

Pressing the [F9] (CANCEL) button returns to the initial screen.

To change a character during the operation

Press the cursor ↑ button, then move the cursor to the title frame; with the cursor ← or → button, change the character insertion position.

When not all characters can be shown within the title frame

On the left or right of the title frame, ← or → appears.

- 6 Press the [F10] (SAVE/EXIT) button.

This return to the initial menu screen.

To change time data

To write the current time data, use the cursor buttons to align the entry cursor with the line in which you want to write.

To move the cursor with the numeric buttons

Enter a line number with the numeric buttons, and press the [F9] (CUENUM POINT) button. The cursor moves to the line number you entered.

Note

If the cursor buttons are not linked to movement of the entry cursor, it is not possible to move the entry cursor ► with the cursor buttons.

To link the cursor buttons to movement of the entry cursor

Press the cursor center button. To unlink, press the cursor center button once again.

Press the ENTRY button to write the current time data over the time data in the line in which the entry cursor ► is present.

Note

If you press the ENTRY button when the entry cursor is not on the screen, the time data of the line in which the entry cursor ► is currently present is written and displayed on the screen.

To enter the current time data as a new line

- 1 With the cursor buttons, move the entry cursor to the line below the position in which you want to insert.

For how to move the cursor, see “To change time data” above.

- 2 Hold down the SFT button and press the ENTRY button.

The line is inserted immediately before the line on which the entry cursor is present, and the current time data is written.

To delete a time code

- 1 Use the cursor buttons to move the cursor to the Time section to be deleted.

To move the cursor using the numeric buttons

Enter the line number using the numeric buttons. Then press the [F9] (CUENUM POINT) button. The cursor will move to the line specified by the numeric buttons.

- 2 Press the [F5] (DEL POINT) button.

A deletion confirmation window appears.

- 3 Press the [F5] (DEL POINT) button while holding down the SFT button.

The time code section becomes blank and is ready for new time data input.

To delete the line as well as the time code

Use the cursor buttons to move the cursor to the time code to be deleted.

Then press the [F5] (DEL POINT) button while holding down the SFT button. The line is deleted and all the line numbers below are decreased by one.

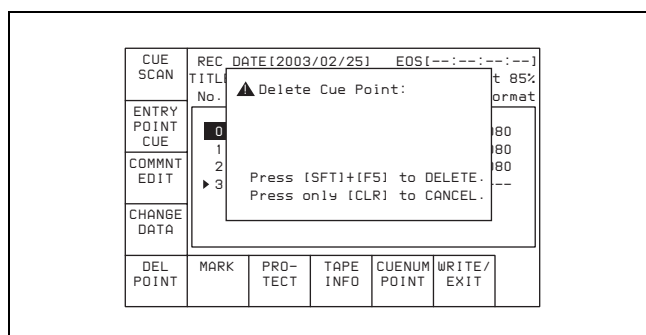

To undo the deletion of a time data or line

Press the ALT/[F2] (UNDO ALL) buttons.

A message appears (in the control panel display) requesting confirmation of the undo operation.

Press the [F2] (UNDO ALL) button while holding down the SFT button. To cancel the undo operation, press the CLR button.

To copy time data of a cue point to another cue point specified in the CUE menu

- 1 Press the ALT/[F4] (COPY to CUE) buttons.

A copy confirmation window appears.

To cancel the copy operation

Press the CLR button.

- 2 Press the [F4] (COPY to CUE) button while holding down the SFT button.

The time data of the cue point is copied to the cue point indicated in the CUE menu.

Changing Mrk data

Use the cursor buttons to move the cursor to the line with the mark attribute to be changed, and then press the [F6] (MARK) button. Or, move the cursor directly to the mark

attribute to be changed, and then press the **[F4]** (CHANGE DATA) button. In both cases, each press of the button changes the attribute as follows: OK → NG → KP (KEEP) → blank (no attribute).

Changing the recording starting point setting

Use the cursor buttons to move the cursor to the recording starting point section. Then press the **[F4]** (CHANGE DATA) button. Each press of the button turns the setting “on” (the @ indication appears) or “off” (the indication disappears).

Entering and modifying IN/OUT point data

You can use either the ENTRY button or the numeric buttons to enter and modify IN/OUT point data.

To enter or modify IN/OUT point data using the ENTRY button

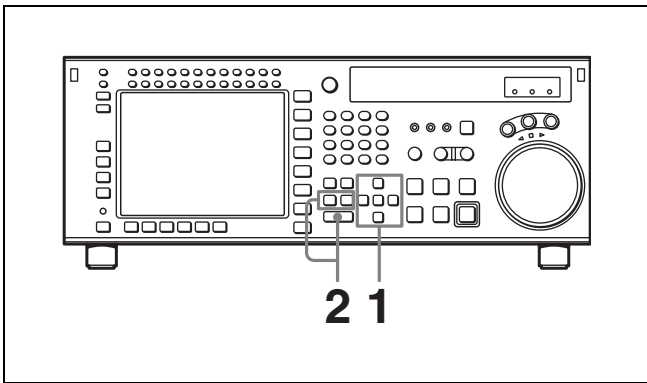

- 1 Use the cursor buttons to move the cursor to the IN/OUT section on which the current log data is to be entered or modified.

To move the cursor using the numeric buttons

Enter the line number using the numeric buttons. Then press the **[F9]** (CUENUM POINT) button. The cursor will move to the line specified by the numeric buttons.

- 2 Press the IN button (to enter IN point data) or OUT button (to enter OUT point data) while holding down the ENTRY button.

The current time code is entered as the IN/OUT point data or it replaces the existing IN/OUT point data.

Note

If the cursor is not on the IN/OUT section when pressing the IN or OUT button while pressing down the ENTRY button, the current cue point is entered or it replaces the existing cue point. When pressing the ENTRY button only, the cue point is entered or replaced regardless of the cursor position.

To enter or modify IN/OUT point data using the numeric buttons

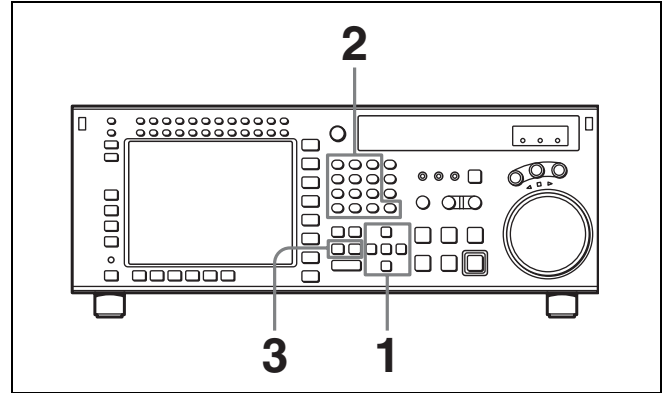

- 1 Use the cursor buttons to move the cursor to the IN/OUT section to be entered or modified.

To move the cursor using the numeric buttons

Enter the line number using the numeric buttons. Then press the **[F9]** (CUENUM POINT) button. The cursor will move to the line specified by the numeric buttons.

- 2 Use the numeric buttons to enter the time data in the data entry window, and then press the SET button.

For example, to enter 00:01:30:00, press the numeric buttons as follows: 0, 0, 1, 3, 0, 0, 0. (There is no need to enter the first zero. When you enter a number that is less than eight digits long, the unspecified digits are automatically set to zero when the SET button is pressed.)

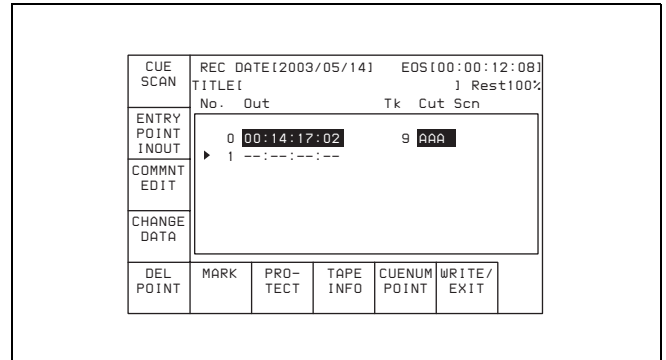

- 3 Press the IN button (to enter IN point data) or OUT button (to enter OUT point data).

The number is entered or it replaces the existing IN/OUT point data.

To clear the IN/OUT point data

Use the cursor buttons to move the cursor to the IN/OUT section to be cleared, and then press the CLR button while holding down the IN button (to clear IN point data) or OUT button (to clear OUT point data), or press the IN or OUT button (to clear both IN and OUT point data) while holding down the CLR button.

To increase or decrease IN/OUT point data one frame at a time

Use the cursor buttons to move the cursor to the IN/OUT section to be increased or decreased, and then press the + button (to increase the time data) or the – button (to decrease the time data) while holding down the IN button or the OUT button. Each time you press the + or – button, the time data is increased or decreased by one frame, respectively.

To recall IN/OUT point data to the data entry window

Use the cursor buttons to move the cursor to the IN/OUT section to be recalled, and then press the RCL button while holding down the IN button (to recall IN point data) or the OUT button (to recall OUT point data).

To enter the current time code continuously

- 1 Set the VTR SETUP menu item 127 “Tele-File IN OUT Input Continue” to “on”.
- 2 Use the cursor buttons to move the cursor to the IN/OUT section to be entered.

To move the cursor using the numeric buttons
Enter the line number using the numeric buttons. Then press the **[F9]** (CUENUM POINT) button. The cursor will move to the line specified by the numeric buttons.
- 3 Press the IN button or OUT button while holding down the ENTRY button.

The movement of the cursor is automatic (as described in the following table) and data is entered continuously.

Input condition	When the IN button you press while holding down the ENTRY button	When the OUT button you press while holding down the ENTRY button
Only IN point data has been entered	IN point data is modified and the cursor stays on the IN point data.	OUT point data is entered and the cursor moves to the next IN point.
Only OUT point data has been entered	IN point data is entered and the cursor moves to the next IN point.	OUT point data is modified and the cursor stays on the OUT point.

To display the duration between an IN point and an OUT point

Use the cursor buttons to move the cursor to the IN/OUT section and press the IN button and OUT button at the same time. The duration between two points appears while the buttons are pressed.

To preroll to an IN/OUT point

Use the cursor buttons to move the cursor to the IN/OUT section and press the IN button (to preroll to an IN point)

or OUT button (to preroll to an OUT point) while holding down the PREROLL button. The VTR prerolls to the point and stops.

For details on setting the preroll time, see “4-2-6 Setting the Preroll Time (PREROLL TIME)” on page 53.

Note

If the cursor is not on the IN/OUT section when pressing the IN/OUT button while pressing the PREROLL button, the VTR prerolls to the cue point. When pressing the PREROLL button only, the VTR prerolls to the cue point regardless of the cursor position.

Automatic time data changes during IN/OUT point data entry or modification

The table below shows the automatic changes that occur in time data when either the IN point or OUT point is changed.

When IN point data is entered or modified:

Status of input data	IN point	OUT point
The time sequence of the IN/OUT point data is correct.	The data is changed.	The data is unchanged.
The time sequence of the IN/OUT point data is not correct.	The data is changed.	The data is deleted.
The OUT point has not been input.	The data is changed.	The data is unchanged.

When OUT point data is entered or modified:

Status of the input data	IN point	OUT point
The time sequence of the IN/OUT point data is correct.	The data is unchanged.	The data is changed.
The time sequence of the IN/OUT point data is not correct.	The data is unchanged.	The data is unchanged.
The IN point has not been input.	The data is unchanged.	The data is changed.

Changing Tk data

Use the cursor buttons to move the cursor to the take data to be changed. Then use the numeric buttons to change the value. Note that values from 0 to 255 can be entered. Or, move the cursor to the take data, and press the **[F4]** (CHANGE DATA) button or the + button repeatedly to increase the value in increments of 1. Press the – button repeatedly to decrease the value in increments of 1. Note that the value cannot go below 0.

Copying data

Use the cursor buttons to move the cursor to the destination Mrk or Tk data, and press the RCL button. The Tk data from the line above is copied to the selected line.

Changing Cut data

Use the cursor buttons to move the cursor to the cut data to be changed, and then enter the new data using the numeric

buttons and +/- buttons. Pressing the - button enters the tilde (~). Press the numeric buttons while pressing down the SFT button to enter uppercase letters (A to J). Note that a maximum of four characters can be entered.

Or, do the procedure below to change the data.

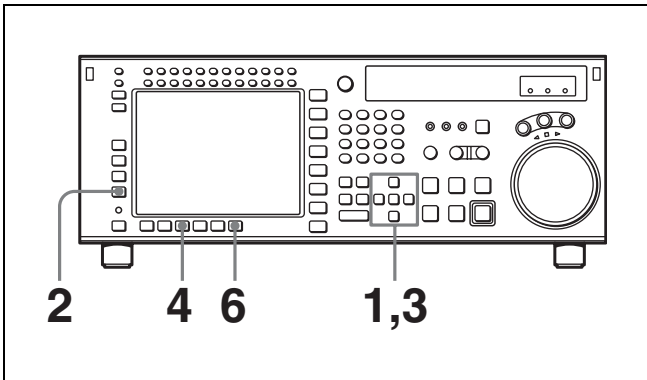

1 Press the cursor buttons to move the cursor to the cut data to be changed.

To move the cursor using the numeric buttons

Enter the line number using the numeric buttons. Then press the [F9] (CUENUM POINT) button. The cursor will move to the line specified by the numeric buttons.

2 Press the [F4] (CHANGE DATA) button.

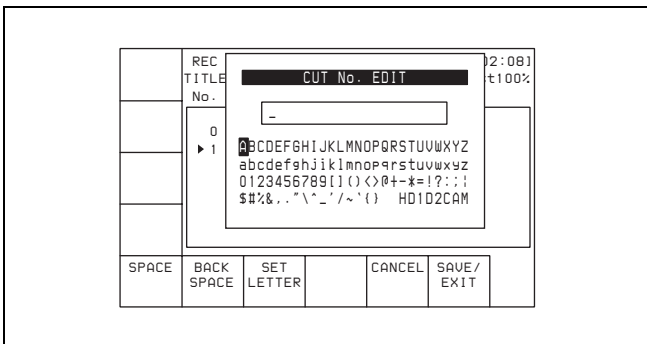

3 Press the ← or → button to select a character.

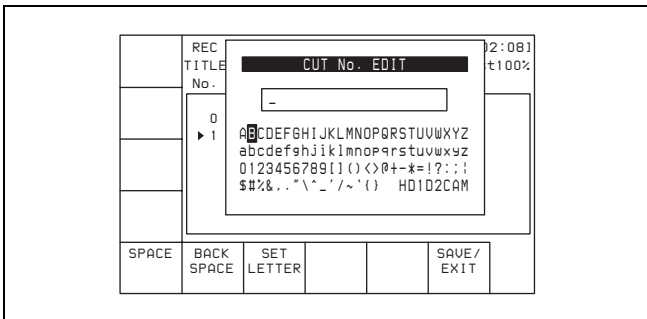

4 Press the [F7] (SET LETTER) button or the cursor center button.

The selected character is entered.

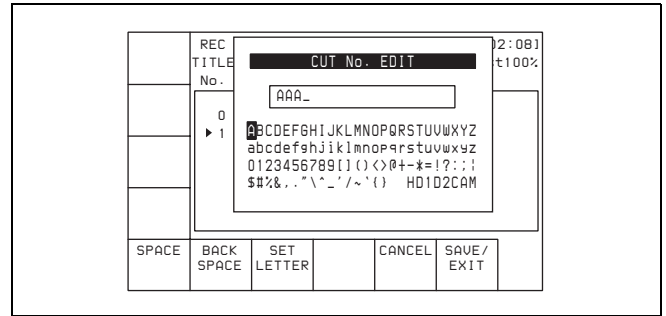

5 Repeat steps 3 and 4 to enter more characters.

To enter a space

Press the [F5] (SPACE) button.

If you enter a wrong character

Press the [F6] (BACK SPACE) button to go back. Then re-enter the character.

To start the procedure over again

Press the [F9] (CANCEL) button to start again.

To change a character

Press the cursor ↑ button to move the cursor to the cut data to be changed. Then press the cursor ← or → button to move the insertion position.

6 Press the [F10] (SAVE/EXIT) button.

The screen that was on before the cut data was changed is displayed again.

To copy Cut data

Move the cursor to the line to which the copied data is to be pasted. Then press the RCL button. The cut data from the line above is copied to the selected line.

Changing scene data

Use the cursor buttons to move the cursor to the scene data to be changed. Then enter the characters using the numeric buttons and +/- buttons. Press the numeric buttons while pressing down the SFT button to enter uppercase letters (A to J). A maximum of three characters can be entered.

Or, do the procedure below to change the data.

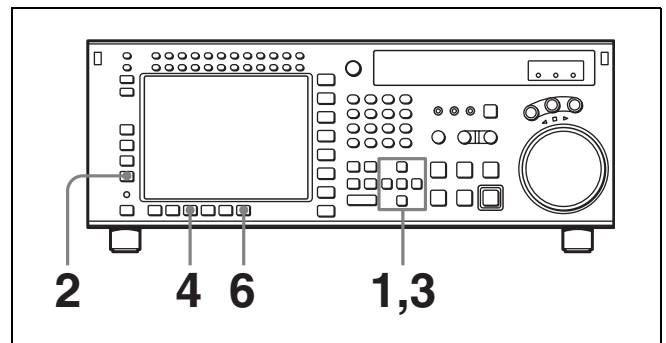

1 Press the cursor buttons to move the cursor to the scene data to be changed.

To move the cursor using the numeric buttons

Enter the line number using the numeric buttons. Then press the **[F9]** (CUENUM POINT) button. The cursor will move to the line specified by the numeric buttons.

- 2** Press the **[F4]** (CHANGE DATA) button.

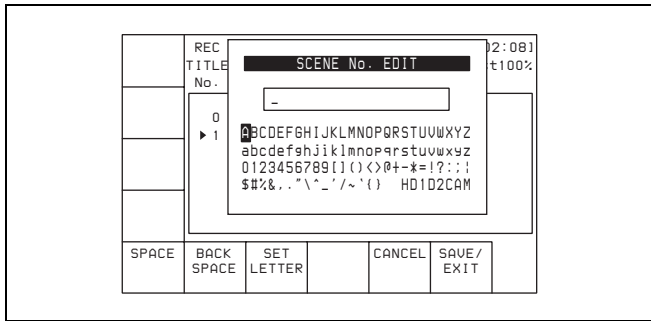

- 3** Press the cursor **←** or **→** button to select a character.

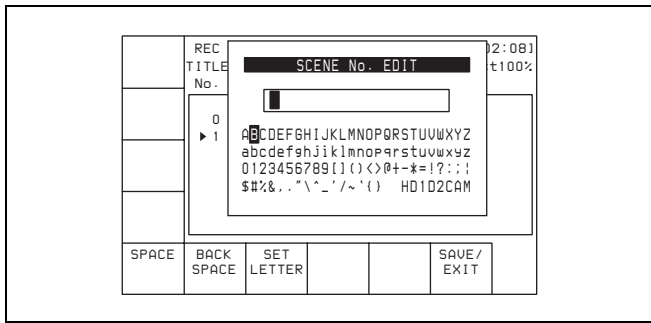

- 4** Press the **[F7]** (SET LETTER) button or the cursor center button.

The selected character is entered.

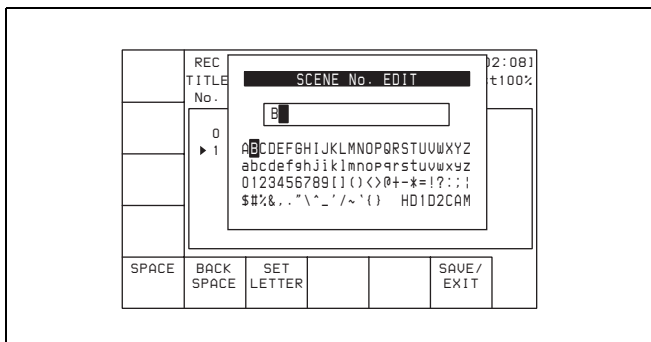

- 5** Repeat steps **3** and **4** to enter more characters.

To enter a space

Press the **[F5]** (SPACE) button.

If you enter a wrong character

Press the **[F6]** (BACK SPACE) button to go back. Then re-enter the character.

To start the procedure over again

Press the **[F9]** (CANCEL) button to start again.

To change a character

Press the cursor **↑** button to move the cursor to the scene data to be changed. Then press the cursor **←** or **→** button to move the insertion position.

- 6** Press the **[F10]** (SAVE/EXIT) button.

The screen that was on before the scene data was entered is displayed again.

To copy Scn data

Move the cursor to the line to which the copied data is to be pasted. Then press the RCL button.

The scene data from the line above is copied to the selected line.

Changing Comment data

To display comment data, press the **→** button several times.

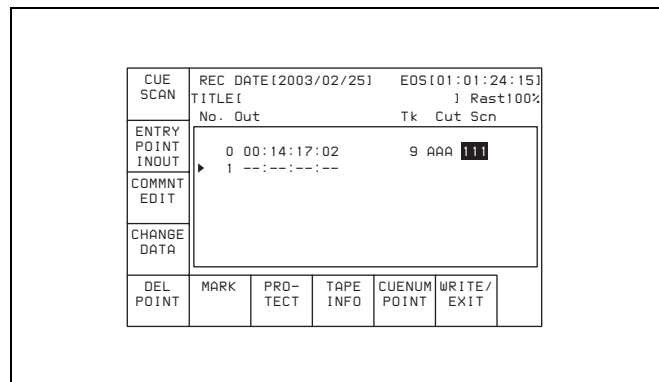
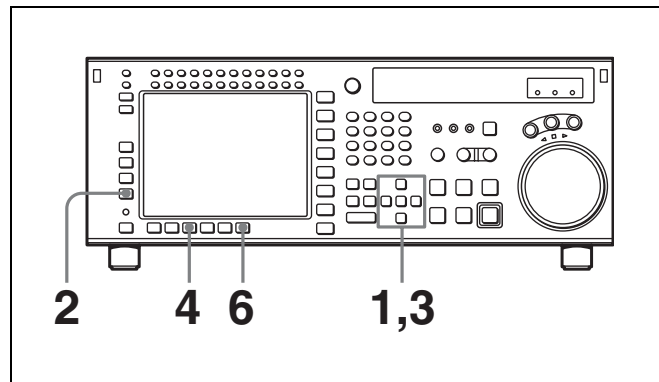
**To change Comment data**

- 1** Press the cursor buttons to move the cursor to the comment to be changed.

To move the cursor using the numeric buttons

Enter the line number using the numeric buttons. Then press the **[F9]** (CUENUM POINT) button. The cursor will move to the line specified by the numeric buttons.

- 2** Press the **[F3]** (COMMNT EDIT) button.

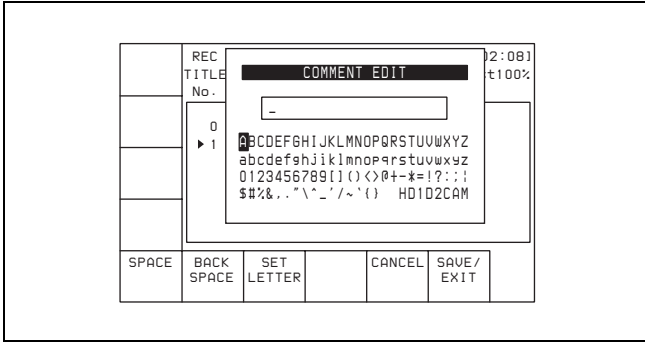

- 3** Press the cursor ← or → button to select a character.

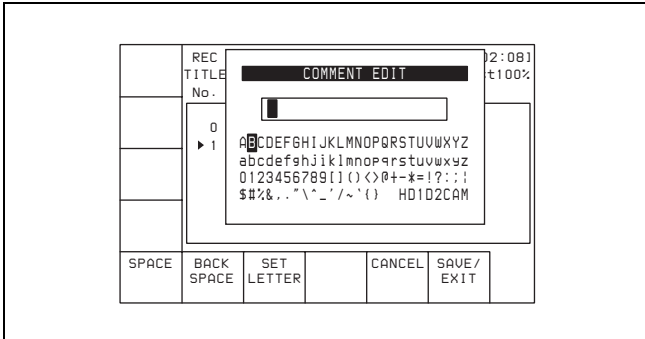

- 4** Press the [F7] (SET LETTER) button or the cursor center button.

The selected character is entered.

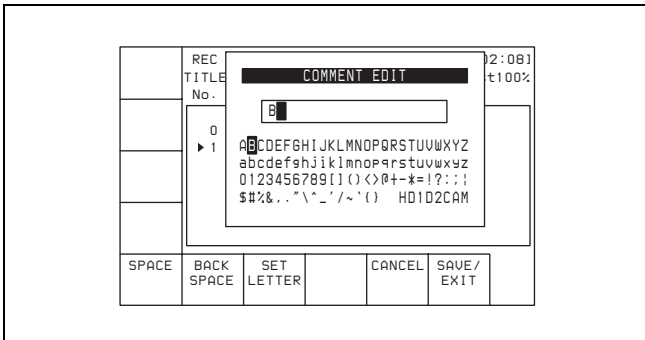

- 5** Repeat steps **3** and **4** to enter more characters.

Up to 80 characters can be entered.

Note

If excessive comment data are entered, the input of cue point data may become disabled. To prevent this, press the [F8] (TAPE INFO) button to check the available memory.

To enter a space

Press the [F5] (SPACE) button.

If you enter a wrong character

Press the [F6] (BACK SPACE) button to go back. Then re-enter the character.

To start the procedure over again

Press the [F9] (CANCEL) button to start again.

To change a character

Press the cursor ↑ button to move the cursor to the comment to be changed. Then press the cursor ← or → button to move the insertion position.

If the entered text is longer than the comment box ◀ or ▶ appears to the left or right of the box.

- 6** Press the [F10] (SAVE/EXIT) button.

The screen that was on before the comment data was changed is displayed again.

Prerolling to a cue point

- 1** Press the [F1] (CUE SCAN) button repeatedly to specify the direction in which the cursor moves when the PREROLL button is pressed.

Each press of the button changes the direction as follows: FWD (forward) → REW (reverse) → unspecified.

FWD: Pressing the PREROLL button causes the cursor to move to the next line, and the VTR to preroll to the time code on that line. Invalid time codes are ignored.

REW: Pressing the PREROLL button causes the cursor to move to the previous line, and the VTR to preroll to the time code on that line. Invalid time codes are ignored.

- 2** Press the PREROLL button.

Write-protecting cue point data

Press the cursor buttons to move the cursor to the line that is to be write-protected. Then press the [F7] (PROTECT) button. P appears between the Time and Mrk columns to indicate that the line (clip) is write-protected.

CUE SCAN	REC DATE[2003/02/25]	EOS[01:01:24:15]			
TITLE[J Rast100%				
No.	Time	Mrk	Tk	Cut	Scn
0	00:01:02:03	NG			00:01:01:03
1	00:03:04:03	OK P			00:03:03:03
2	00:03:04:03	OK	0		00:03:03:03
3	00:04:04:03	OK			00:04:03:03
4	00:05:05:03	NG			00:05:04:03
5	00:06:06:03	OK			00:06:05:03
6	00:06:06:03				

DEL POINT	MARK	PRO-TECT	TAPE INFO	CUENUM POINT	WRITE/EXIT
-----------	------	----------	-----------	--------------	------------

To cancel a write-protection

Press the [F7] (PROTECT) button. A message appears (in the control panel display) requesting confirmation of cancellation operation.

Press the **[F7]** (PROTECT) button while holding down the SFT button.

Inserting a new line

- 1 Use the cursor buttons to move the cursor to the line that will be under the new line to be inserted.

To move the cursor using the numeric buttons

Enter the line number using the numeric buttons. Then press the **[F9]** (CUENUM POINT) button. The cursor will move to the line specified by the numeric buttons.

Note

If the movement of the cursor (▶) is not linked with the cursor buttons, the cursor (▶) will not move when the cursor buttons are pressed.

To link the cursor (▶) with the cursor buttons

Press the cursor center button. Each press of the button alternately links and unlinks the cursor (▶).

- 2 Press the ENTRY button while holding down the SFT button.

A new line is inserted above the line where the cursor (▶) is located, and the current time data is entered on the new line.

Moving a line

Press the cursor buttons to move the cursor to the Time data of the line to be moved. Then press the + or – button. Each press of the + button moves the line up, while each press of the – button moves the line down.

Note

If you perform the procedure above while the cursor is on any other data other than the Time data, only the contents selected by the cursor will be moved. To move the entire line, be sure that the cursor is placed on the Time data.

Deleting a line

Press the cursor button to move the cursor to the line to be deleted, and then press the **[F5]** (DEL POINT) button while pressing down the SFT button. The line is deleted and all the line numbers below are decreased by one.

Displaying other information saved to the MLB-1M-100 memory label

Press the **[F8]** (TAPE INFO) button. The TAPE INFORMATION window appears, showing other information.

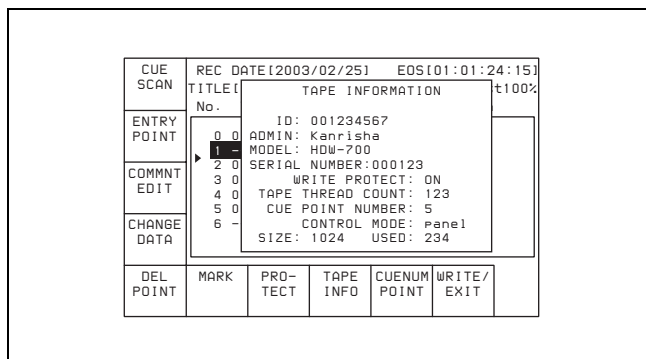

To close the window

Press the **[F8]** (TAPE INFO) button again.

To change ID or ADMIN data

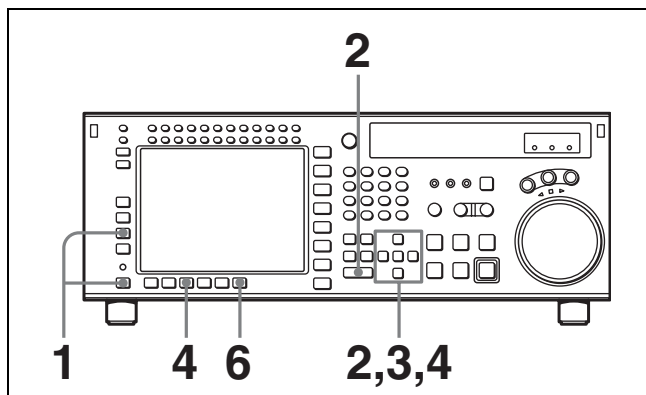

- 1 Press the ALT/**[F3]** (ATTRIB EDIT) buttons.
- 2 Press the ↑ or ↓ button to select “ID” (tape ID) or “ADMIN” (administrator), then press the ENTRY button.

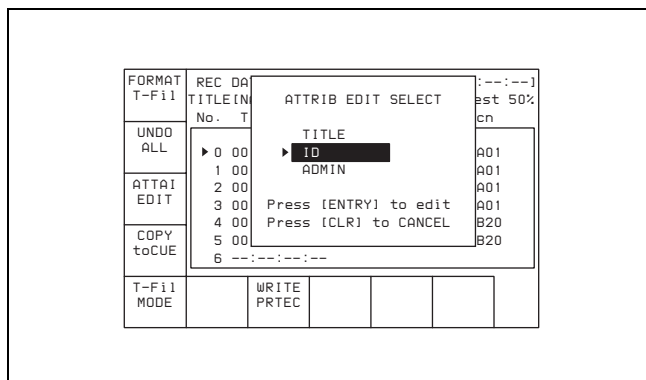

- 3 Press the ← or → button to select a character.

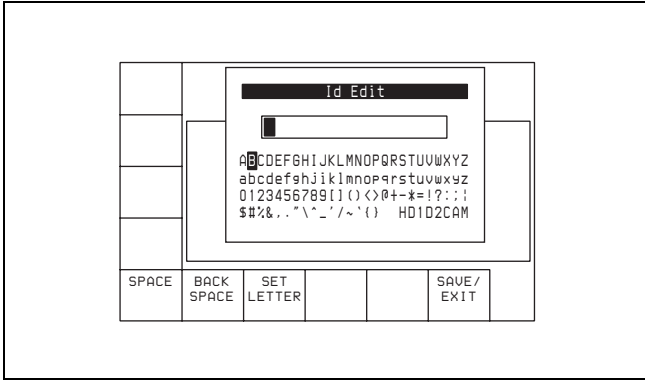

- 4** Press the **[F7]** (SET LETTER) button or the cursor center button.

The selected character is entered.

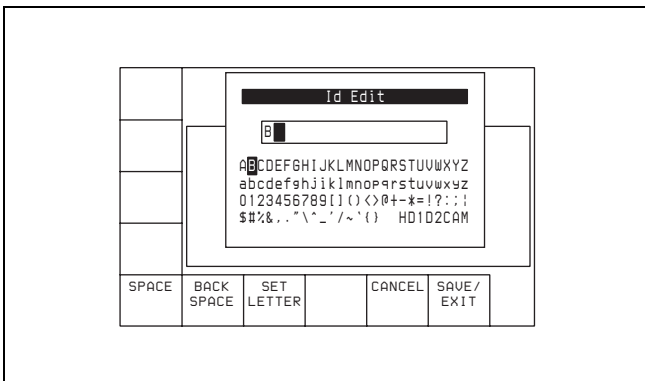

- 5** Repeat steps **3** and **4** to enter more characters.

To enter a space

Press the **[F5]** (SPACE) button.

If you enter a wrong character

Press the **[F6]** (BACK SPACE) button to go back.
Then re-enter the character.

To start the procedure over again

Press the **[F9]** (CANCEL) button to start again.

To change a character

Press the cursor **↑** button to move the cursor to the ID or ADMIN box. Then press the cursor **←** or **→** button to move the insertion position.

If entered text is longer than the ID or ADMIN box

◀ or **▶** appears to the left or right of the box.

- 6** Press the **[F10]** (SAVE/EXIT) button.

The screen that was on before the ID or ADMIN data was changed is displayed again.

4-5 VIDEO Menu

In the VIDEO menu, adjust the video signal. The VIDEO menu screen shows the VTR operation mode, current position time code, time code type, and so on.

About HD image quality adjustments

When playing back tapes recorded in Y/P_B/P_R (4:2:2) format, HD image quality adjustments are enabled for the HD SDI OUTPUT 1, 2, and MONITOR connectors.

Note

HD image quality adjustments are not possible when playing back tapes recorded in GBR (4:4:4) format. Also, HD image quality adjustments are not possible when the optional HKSR-5001 Format Converter Board is installed and Y/P_B/P_R (4:2:2) format signals are output from the FORMAT CONV. OUT (OPTION) 1 and 2 connectors.

To access the VIDEO menu screen

Press the VIDEO button.

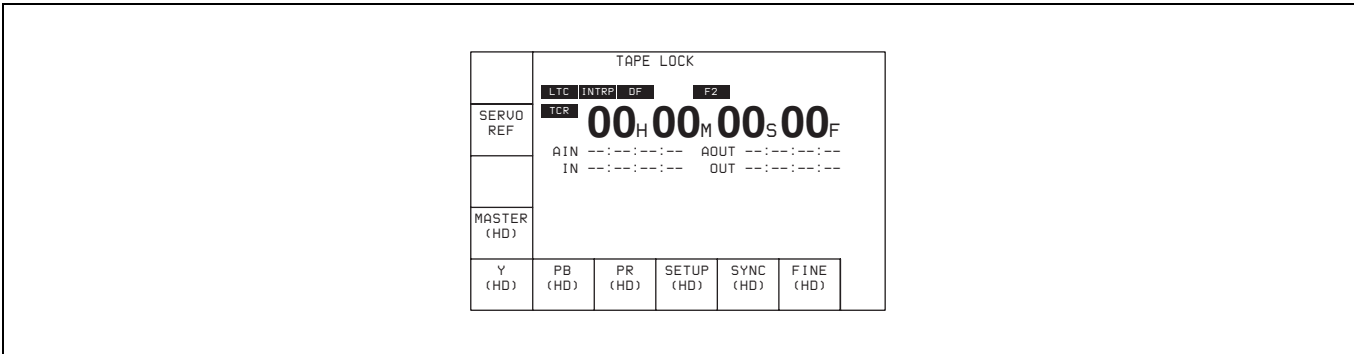

Button	Indication	Function	Settings
[F2]	SERVO REF	Selects the reference signal for output.	ext, input, auto
[F4]	MASTER (HD)	Adjusts the Y, P _B , and P _R output levels simultaneously.	prst, 0.0 to 141.3%
[F5]	Y (HD)	Adjusts the Y output level.	prst, 0.0 to 141.3%
[F6]	P _B (HD)	Adjusts the P _B output level.	prst, 0.0 to 141.3%
[F7]	P _R (HD)	Adjusts the P _R output level.	prst, 0.0 to 141.3%
[F8]	SETUP (HD)	Adjusts the setup level.	prst, -10.0 to +10.0
[F9]	SYNC (HD)	Adjusts the sync phase.	prst, -128 to +127
[F10]	FINE (HD)	Fine adjustment of the sync phase.	prst, 0 to 1024
ALT/[F1]	MASTER LEVEL (D1)	Adjusts the Y, B-Y, and R-Y output levels simultaneously.	prst, 0.0 to 141.3%
ALT/[F2]	Y LEVEL (D1)	Adjusts the Y output level.	prst, 0.0 to 141.3%
ALT/[F3]	B-Y LEVEL (D1)	Adjusts the B-Y output level.	prst, 0.0 to 141.3%
ALT/[F4]	R-Y LEVEL (D1)	Adjusts the R-Y output level.	prst, 0.0 to 141.3%
ALT/[F5]	VIDEO GAIN (ALL)	Adjusts the video gain.	prst, 0.0 to 141.3%
ALT/[F6]	CHROMA GAIN (ALL)	Adjusts the chroma gain.	prst, 0.0 to 141.3%
ALT/[F7]	CHROMA PHASE (ALL)	Adjusts the chroma phase.	prst, -127 to +127
ALT/[F8]	BLACK LEVEL (ALL)	Adjusts the black level.	prst, -31.0 to +31.0%
ALT/[F9]	SETUP LEVEL (CST)	Adjusts the setup level.	prst, 0 to +10.0

4-5-1 Selecting the Reference Signal (SERVO REF)

Press the **[F2]** (SERVO REF) button to select the signal to be used as the reference signal for VTR operations.

ext: The servo reference signal is forced to be EXT.

input: The signal from the HD SDI INPUT A/B connector is used as the reference signal for VTR operations.

auto: During recording or edit preset, the signal from the HD SDI INPUT A/B connector is used as a reference signal. In all other cases, the servo operates using the signal setting of the VTR SETUP menu item 006 “EXTERNAL REFERENCE select”. If the signal selected in the menu item 006 “EXTERNAL REFERENCE select” is not present, the servo operates using an internal reference.

4-5-2 Adjusting the Output Video Signal (MASTER to FINE)

Adjusting the output video signal

Set the output video signal menu items as follows.

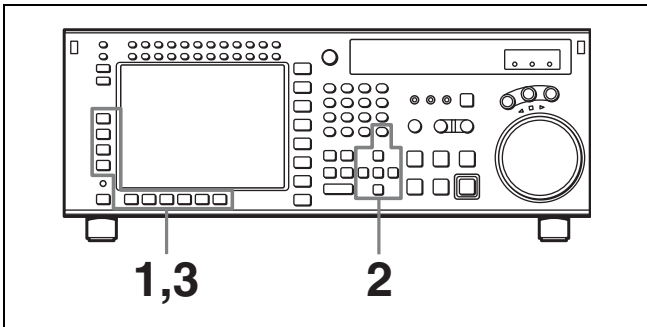

- 1 Press the function selection button (**[F4]**, for example).

The setting display lights up.

- 2 With the **↑** and **↓** buttons (or MULTI CONTROL knob), change the numeric value.

Setting to the preset values

Press the cursor center button or MULTI CONTROL knob.

The prst (preset) indication appears.

- 3 At the desired setting value, press the function selection button (**[F4]**, for example).

The numeric values change as follows.

[F4] button MASTER (HD): Pressing this button makes it active, and the cursor **↑** and **↓** buttons increase or

decrease the value by 0.1. You can also change the setting with the MULTI CONTROL knob.

[F5] button Y (HD): Pressing this button makes it active, and the cursor **↑** and **↓** buttons increase or decrease the value by 0.1. You can also change the setting with the MULTI CONTROL knob.

[F6] button PB (HD): Pressing this button makes it active, and the cursor **↑** and **↓** buttons increase or decrease the value by 0.1. You can also change the setting with the MULTI CONTROL knob.

[F7] button PR (HD): Pressing this button makes it active, and the cursor **↑** and **↓** buttons increase or decrease the value by 0.1. You can also change the setting with the MULTI CONTROL knob.

[F8] button SETUP (HD): Pressing this button makes it active, and the cursor **↑** and **↓** buttons increase or decrease the value by 0.5. You can also change the setting with the MULTI CONTROL knob.

[F9] button SYNC (HD): Pressing this button makes it active, and the cursor **↑** and **↓** buttons increase or decrease the value by 1. You can also change the setting with the MULTI CONTROL knob.

[F10] button FINE (HD): Pressing this button makes it active, and the cursor **↑** and **↓** buttons increase or decrease the value by 1. You can also change the setting with the MULTI CONTROL knob.

ALT/[F1] button MASTER: Pressing these buttons make them active, and the cursor **↑** and **↓** buttons increase or decrease the value by 0.1. You can also change the setting with the MULTI CONTROL knob.

ALT/[F2] button Y (D1): Pressing these buttons make them active, and the cursor **↑** and **↓** buttons increase or decrease the value by 0.1. You can also change the setting with the MULTI CONTROL knob.

ALT/[F3] button B-Y (D1): Pressing these buttons make them active, and the cursor **↑** and **↓** buttons increase or decrease the value by 0.1. You can also change the setting with the MULTI CONTROL knob.

ALT/[F4] button R-Y (D1): Pressing these buttons make them active, and the cursor **↑** and **↓** buttons increase or decrease the value by 0.1. You can also change the setting with the MULTI CONTROL knob.

ALT/[F5] button V GAIN (ALL): Pressing these button makes it active, and the cursor **↑** and **↓** buttons increase or decrease the value by 0.1. You can also change the setting with the MULTI CONTROL knob.

ALT/[F6] button CRM GA (ALL): Pressing these button makes it active, and the cursor **↑** and **↓** buttons increase or decrease the value by 0.1. You can also change the setting with the MULTI CONTROL knob.

ALT/[F7] button CRM PH (ALL): Pressing these button makes it active, and the cursor **↑** and **↓** buttons increase or decrease the value by 1. You can also change the setting with the MULTI CONTROL knob.

ALT/[F8] button BLK LV (ALL): Pressing these button makes it active, and the cursor **↑** and **↓** buttons

increase or decrease the value by 1. You can also change the setting with the MULTI CONTROL knob. **ALT/[F9] button SETUP (CST):** Pressing these buttons make them active, and the cursor ↑ and ↓ buttons increase or decrease the value by 0.1. You can also change the setting with the MULTI CONTROL knob.

Adjusting the master output level (HD)

Make this adjustment with the [F4] (MASTER LEVEL) button.

prst: 100% (4000H)

Numerical value: 0.0 (0H) to 141.3% (5A70H)

Adjustable range: $-\infty$ to +3 dB

This setting can also be carried out in the VTR SETUP menu item 708 “MASTER LEVEL (HD)”.

Adjusting the Y output level (HD)

Make this adjustment with the [F5] (Y (HD)) button.

prst: 100% (4000H)

Numerical value: 0.0 (0H) to 141.3% (5A70H)

Adjustable range: $-\infty$ to +3 dB

This setting can also be carried out in the VTR SETUP menu item 709 “Y LEVEL (HD)”.

Adjusting the P_B output level (HD)

Make this adjustment with the [F6] (PB (HD)) button.

prst: 100% (4000H)

Numerical value: 0.0 (0H) to 141.3% (5A70H)

Adjustable range: $-\infty$ to +3 dB

This setting can also be carried out in the VTR SETUP menu item 710 “PB LEVEL (HD)”.

Adjusting the P_R output level (HD)

Make this adjustment with the [F7] (PR LEVEL) button.

prst: 100% (4000H)

Numerical value: 0.0 (0H) to 141.3% (5A70H)

Adjustable range: $-\infty$ to +3 dB

This setting can also be carried out in the VTR SETUP menu item 711 “PR LEVEL (HD)”.

Adjusting the setup level (HD)

Make this adjustment with the [F8] (SETUP LEVEL) button.

prst: 0% (0)

Numerical value: -10.0 to +10.0

Adjustable range: -10 to +10%

This setting can also be carried out in the VTR SETUP menu item 712 “SETUP LEVEL (HD)”.

Adjusting the sync phase (HD)

Use this setting to precisely match the output phase of the VTR to the reference signal or when using a switcher or

other device connected to another VTR to create special effects such as fading, wrapping, and dissolving.

To adjust the output signal sync phase with respect to the reference input, make this adjustment with the [F9] (SYNC PHASE) button.

prst: 0 (0)

Numerical value: -128 to +127

Adjustable range: -1.4 to +1.4H

This setting can also be carried out in the VTR SETUP menu item 713 “SYNC PHASE (HD)”.

Fine adjustment of the sync phase (HD)

Make this adjustment with the [F10] (FINE) button.

prst: 0 (0)

Numerical value: 0 to 1024

Adjustable range: 0 to 323 nsec

This setting can also be carried out in the VTR SETUP menu item 714 “FINE (HD)”.

Adjusting the master output level (D1)

Make this adjustment with the ALT/[F1] (MASTER LEVEL) buttons.

prst: 100% (4000H)

Numerical value: 0.0 (0H) to 141.3%

Adjustable range: $-\infty$ to +3 dB

This setting can also be carried out in the VTR SETUP menu item 755 “MASTER LEVEL (D1)”.

Adjusting the Y output level (D1)

Make this adjustment with the ALT/[F2] (Y LEVEL) buttons.

prst: 100% (4000H)

Numerical value: 0.0 (0H) to 141.3% (5A70H)

Adjustable range: $-\infty$ to +3 dB

This setting can also be carried out in the VTR SETUP menu item 756 “Y LEVEL (D1)”.

Adjusting the R-Y output level (D1)

Make this adjustment with the ALT/[F4] (R-Y LEVEL) buttons.

prst: 100% (4000H)

Numerical value: 0.0 (0H) to 141.3% (5A70H)

Adjustable range: $-\infty$ to +3 dB

This setting can also be carried out in the VTR SETUP menu item 758 “R-Y LEVEL (D1)”.

Adjusting the video gain output level (HD/SD)

Make this adjustment with the ALT/[F5] (V GAIN (ALL)) buttons.

prst: 100% (4000H)

Numerical value: 0.0 (0H) to 141.3% (5A70H)

Adjustable range: 0.0% to 141.3%

This setting can also be carried out in the VTR SETUP menu item 740 “VIDEO GAIN (ALL)”.

Adjusting the chroma gain output level (HD/SD)

Make this adjustment with the ALT/[F6] (CRM GA (ALL)) buttons.

prst: 100% (4000H)

Numerical value: 0.0 (0H) to 141.3% (5A70H)

Adjustable range: 0.0% to 141.3%

This setting can also be carried out in the VTR SETUP menu item 741 “CHROMA GAIN (ALL)”.

Adjusting the chroma phase output level (HD/SD)

Make this adjustment with the ALT/[F7] (CRM PH (ALL)) buttons.

prst: 0

Numerical value: -127 to +127

Adjustable range: -30° to +30°

This setting can also be carried out in the VTR SETUP menu item 742 “CHROMA PHASE (ALL)”.

Adjusting the black output level (HD/SD)

Make this adjustment with the ALT/[F8] (BLK LV (ALL)) buttons.

prst: 0.0% (110H)

Numerical value: -31.0% (0H) to +31.0% (220H)

Adjustable range: -31.0% to +31.0%

This setting can also be carried out in the VTR SETUP menu item 743 “BLACK LEVEL (ALL)”.

Adjusting the setup level (COMPOSITE)

Make this adjustment with the ALT/[F9] (SETUP LEVEL) buttons.

prst: 7.5 IRE

Numerical value: 0 to +10.0

Adjustable range: 0 to +10.0 IRE

This setting can also be carried out in the VTR SETUP menu item 762 “SETUP LEVEL (CST)”.

4-6 AUDIO Menu

In the AUDIO menu, make audio signal adjustments. The AUDIO menu screen shows the VTR operation mode, current position time code, time code type, and so on.

To access the AUDIO menu screen
Press the AUDIO button.

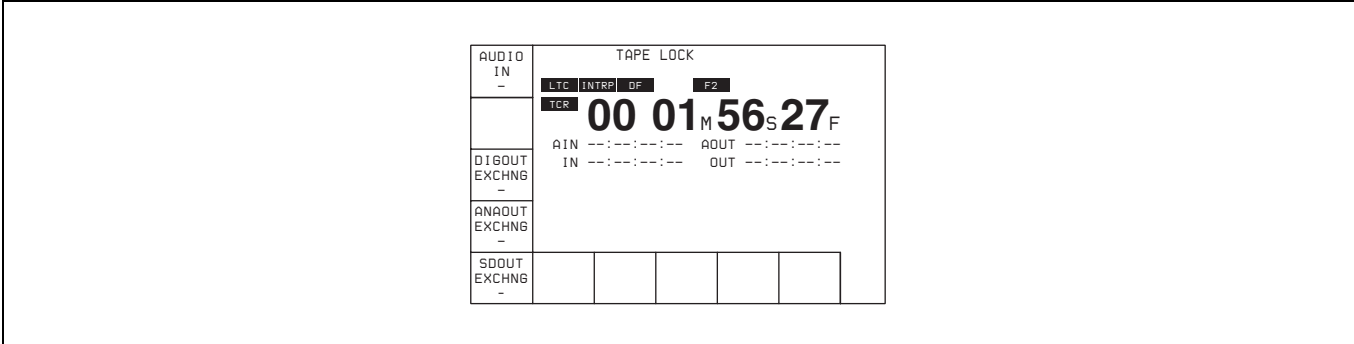

Button	Indication	Function	Settings
[F1]	AUDIO IN	Accesses the AUDIO INPUT menu	SDI, AES/EBU
[F3]	DIGOUT EXCHNG	Digital audio output signal source track selection (HD SDI, SD SDI, AES/EBU) However, [F5] (SDOUT EXCHNG) can be used to set SD SDI source tracks independently.	TR1 to TR12
[F4]	ANAOUT EXCHNG	Analog audio output signal source track selection	TR1 to TR12
[F5]	SDOUT EXCHNG	Digital audio output signal source track selection (SD SDI)	dis, ena, TR1 to TR12
ALT/[F1]	AUDIO EDIT	Audio transition type selection for digital audio editing	cross, fi/fo, cut
ALT/[F2]	FADE TIME	Fade time selection	5 ms to 115 ms
ALT/[F3]	REPLACE MODE	CH1 to CH8 assignment settings in response to an external digital audio preset command	
ALT/[F4]	ANALOG REPLACE	CH9 to CH12 assignment settings in response to an external analog audio preset command	
ALT/[F5]	PITCH GROUP	Sets the relation between audio channels when performing pitch correction during program play or play at a different frequency (23.98 frame ↔ 24 frame, 23.98/24 frame ↔ 25 frame, 29.97 frame ↔ 30 frame).	

Display when audio output channel settings do not match track number settings

- As shown below, "EXCHNG" is displayed if even one of the HD SDI, AES/EBU, ANALOG, SD SDI output channels does not match the corresponding track number.

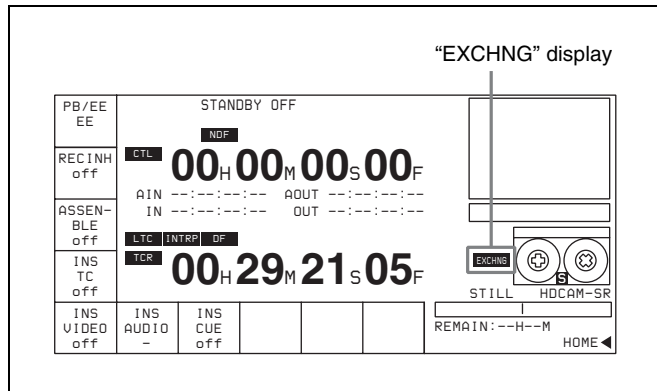

- The [F3] button in the AUDIO menu is highlighted in orange if even one of the HD SDI, AES/EBU audio output channels does not match the corresponding track

number on the tape.

In this case, if SDOUT EXCHNG is set to “dis”, the [F5] button is also highlighted in orange.

- The [F4] button in the AUDIO menu is highlighted in orange if even one of the ANALOG audio output channels does not match the corresponding track number on the tape.
- The [F5] button in the AUDIO menu is highlighted in orange if even one of the SD SDI audio output channels does not match the corresponding track number on the tape.

4-6-1 Selecting the Audio Input Signal (AUDIO IN)

To select the audio input signal for CH1 to CH12, use the following procedure.

CH1 to CH12 can be selected for HDCAM-SR, and CH1 to CH4 can be selected for HDCAM.

- 1 Press the [F1] (AUDIO IN) button.

The AUDIO INPUT menu appears, together with an audio input selection window.

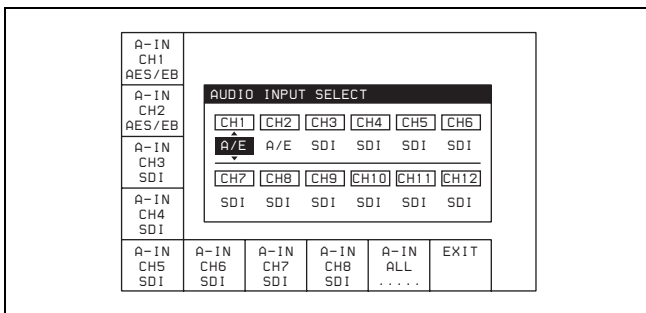

- 2 Select the audio input signal for each channel.

SDI: audio signal input from the HD SDI INPUT A/B connector

AES/EBU: audio signal input from the DIGITAL I/O (AES/EBU) INPUT connector

- 3 Press the [F10] (EXIT) button.

This returns to the AUDIO menu screen.

To make settings for individual channels with the F buttons

By pressing any of the [F1] (A-IN CH1) to [F8] (A-IN CH8) buttons in the AUDIO INPUT menu, and the [F1] (A-IN CH9) to [F4] (A-IN CH12) buttons in the ALT+AUDIO screen obtained by pressing the ALT button, you can select the type of input signal for each channel.

To make input signal selections for individual channels with the numeric buttons

- 1 Press the cursor ← or → button, to align the cursor with the channel for which you want to make the selection.
- 2 Press the cursor ↑ or ↓ button, to select the signal.

To return to the default settings

Press the cursor center button. The cursor item returns to the default.

To select the same input signal simultaneously on all twelve channels

Press the [F9] (A-IN ALL) button to change the input signal simultaneously on all twelve channels.

You can also make this setting using the VTR SETUP menu item 830 “AUDIO INPUT SELECT”.

4-6-2 Digital Audio Output Signal Source Track Selection (DIGOUT EXCHNG)

To make the source track selection for the digital audio output signal (audio multiplexed with HD SDI and SD SDI (1 to 8 channels), and AES/EBU audio output are targeted) on each of channels 1 to 12, use the following procedure. Note that when [F9] (SDOUT EXCHNG) in the SDOUT menu is set to “ena”, SD SDI source track selection follows the settings of the SDOUT menu.

- 1 Press the [F3] (DIGOUT EXCHNG) button.

The DIGOUT menu appears, together with a source track selection window for the digital audio output signals.

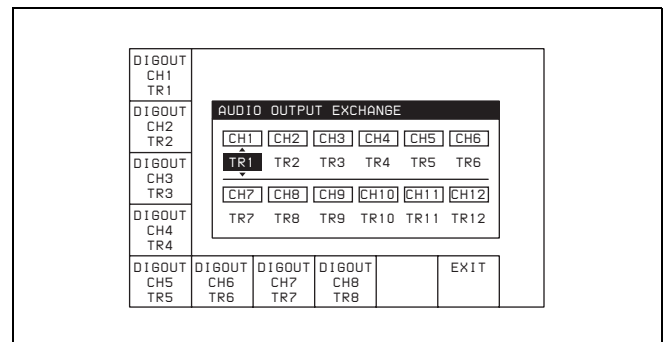

- 2 Carry out the source track selection for the digital audio output signal on each channel.

TR1 to TR12: Select the audio signals recorded on tracks 1 to 12.

- 3 Press the [F10] (EXIT) button.

This returns to the AUDIO menu screen.

To make output settings for individual channels with the F buttons

By pressing any of the **[F1]** (DIGOUT CH1 TR1) to **[F8]** (DIGOUT CH8 TR8) buttons menu, and the **[F1]** (DIGOUT CH9) to **[F4]** (DIGOUT CH12) buttons in the ALT+DIG OUT screen obtained by pressing the ALT button, you can select the source track for each channel.

To make input signal selections for individual channels with the numeric buttons

- 1 Press the cursor ← or → button, to align the cursor with the channel for which you want to make the selection.
- 2 Press the cursor ↑ or ↓ button, to select the source track to be output.

To return to the default settings

Press the cursor center button. The cursor item returns to the default.

You can also make this setting using VTR SETUP menu item 834 “DIGITAL AUDIO OUTPUT EXCHANGE”.

4-6-3 Analog Audio Output Signal Source Track Selection (ANAOUT EXCHNG)

To make the source track selection for the analog audio output signal on each of CH1 to CH4, use the following procedure.

- 1 Press the **[F4]** (ANAOUT EXCHNG) button.

The ANAOUT menu appears, together with a source track selection window for the analog audio output signals.

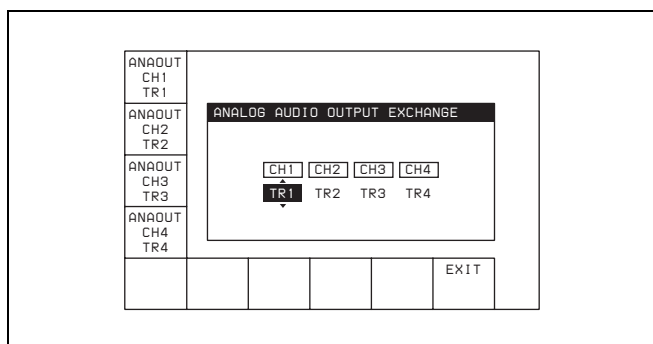

- 2 Carry out the source track selection for the analog audio output signal on each channel.

TR1 to TR12: Select the audio signals recorded on tracks 1 to 12.

- 3 Press the **[F10]** (EXIT) button.

This returns to the AUDIO menu screen.

To make output settings for individual channels with the F buttons

By pressing any of the **[F1]** (ANAOUT CH1 TR1) to **[F4]** (ANAOUT CH4 TR4) buttons, you can select the source track for each channel.

To make input signal selections for individual channels with the numeric buttons

- 1 Press the cursor ← or → button, to align the cursor with the channel for which you want to make the selection.
- 2 Press the cursor ↑ or ↓ button, to select the source track to be output.

To return to the default settings

Press the cursor center button. The cursor item returns to the default.

You can also make this setting using VTR SETUP menu item 835 “ANALOG AUDIO OUTPUT EXCHANGE”.

4-6-4 Digital Audio Output Signal Source Track Selection (SDOUT EXCHNG)

To make the source track selection for the digital audio output signal (audio multiplexed with SD SDI), use the following procedure.

- 1 Press the **[F5]** (SDOUT EXCHNG) button.

The SDOUT menu appears, together with a source track selection menu for the digital audio output signals.

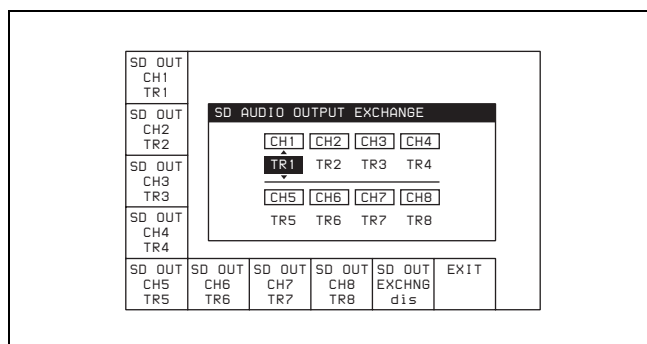

- 2 Press **[F9]** (SD OUT EXCHNG) to set the display to “ena”s.

ena: Enable the settings of this menu.

dis: Disable the settings of this menu, and use the settings for CH1 to CH8 of DIGOUT EXCHNG.

- 3 Select the digital audio output signal for each channel.

TR1 to TR2: Output the audio signals recorded on tracks 1 to 12.

- 4 Press the **[F10]** (EXIT) button.

This returns to the AUDIO menu.

Making output settings for individual channels with the F buttons

By pressing any of the **[F1]** (SDOUT CH1 TR1) to **[F8]** (SDOUT CH8 TR8) buttons, you can select the source track for each channel.

Making input signal selections for individual channels with the numeric buttons

- 1 Press the cursor **←** or **→** button, to align the cursor with the channel for which you want to make the selection.
- 2 Press the cursor **↑** or **↓** button, to select the source channel to be output.

To return to the default settings

Press the cursor center button. The cursor item returns to the default.

You can also make this setting using the VTR SETUP menu item 836 “SD AUDIO OUTPUT EXCHANGE”.

4-6-5 Audio Transition Type Selection for Digital Audio Editing (AUDIO EDIT)

To select the digital audio transition type at edit points, use the following procedure.

- 1 In the AUDIO menu, press the ALT button.

The AUDIO EDIT menu opens, and an edit image window appears.

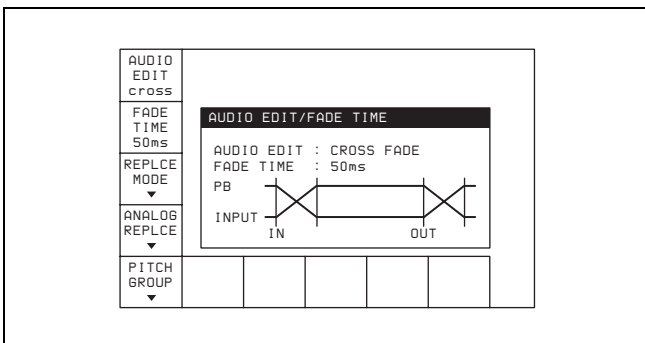

- 2 Press the ALT/**[F1]** (AUDIO EDIT) buttons to select the transition type.

Each press of the buttons selects a transition type in the order CUT → CROSS → FADE IN/OUT. At the same time, the display in the edit image window changes to reflect the selected type.

You can also make this setting using the VTR SETUP menu item 317 “AUDIO EDIT MODE”.

4-6-6 Fade Processing Time Selection for Digital Audio Editing (FADE TIME)

To select the fade processing time for digital audio at edit points, use the following procedure.

Note

The fade processing time cannot be changed when the audio transition type has been set to CUT with the ALT/**[F1]** (AUDIO EDIT) buttons.

- 1 Press the ALT/**[F1]** (AUDIO EDIT) buttons, and select CROSS or FADE IN/OUT.

The FADE TIME menu appears.

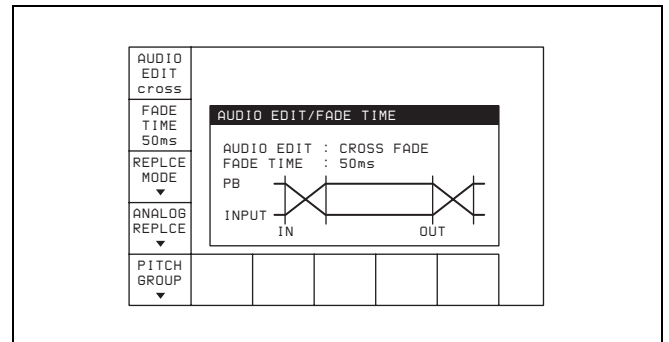

- 2 Press the ALT/**[F2]** (FADE TIME) button to select the fade time.

Each press of the button changes the setting in the range 5 ms to 115 ms. At the same time, the display in the edit image window changes to reflect the selected time.

You can also make this setting using the VTR SETUP menu item 811 “DIGITAL AUDIO FADE TIME”.

4-6-7 External Device Audio Edit Preset Command Replace Mode Selection (EDIT PRESET REPLACE CHANNEL SELECT)

You can replace channel settings for audio edit preset commands received from editors and other external devices. This function allows such devices to control channels 1 to 12 on this unit.

- 1 Press the ALT/[F2] (REPLCE CH SEL) buttons.

The REPL CH SEL menu appears, together with the edit preset channel selection menu for each channel on this unit.

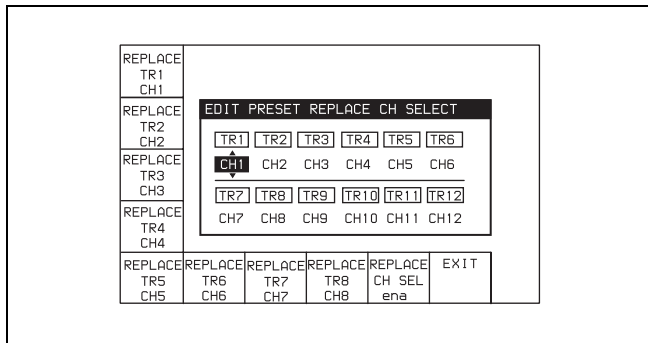

- 2 Press the [F9] (REPLCE CH SEL) button repeatedly until “ena” is displayed.

ena: The settings of this menu are enabled.
dis: The settings of this menu are disabled and the settings made in EDIT PRESET REPLACE MODE SELECT and ANALOG AUDIO EDIT PRESET REPLACE are used.

- 3 Select the edit preset channel for each channel.
CH1 to CH12: The edit preset channel of the selected edit preset channel controls the channel of this unit.

- 4 Press the [F10] (EXIT) button.

The ALT+AUDIO menu appears again.

Setting channels for individual tracks using the F button

You can set channels for individual tracks by pressing the [F1] (REPLCE TR1) to [F8] (REPLCE TR8) buttons, or by pressing the ALT button to go to the ALT+REPL CH menu, and then pressing [F1] (REPLCE TR9) to [F4] (REPLCE TR12) buttons.

Setting channels for individual tracks with the numeric buttons

- 1 Press the cursor ← or → button to align the cursor with the track to be assigned with a channel.
- 2 Press the cursor ↑ or ↓ button to select the channel.

To restore the default settings

Press the cursor center button. The item selected by the cursor is restored to its default setting.

To restore all tracks to their default channel settings

Press the [F9] (REPLCE CH ALL) button in the ALT+REPL CH menu.

All tracks are restored to their default settings.

You can also do the above procedure with the VTR SETUP menu item “310: EDIT PRESET REPLACE CHANNEL SELECT”.

4-6-8 External Device Digital Audio Edit Preset Command Replace Mode Selection (AUDIO EDIT PRESET REPLACE)

You can replace the channel settings for digital audio edit preset commands received from editors and other external devices. For example, some devices are capable of issuing digital audio edit preset commands only for channels 1 to 4 (CH1 to CH4). This function allows such devices to control channels 1 to 8 on this unit.

- 1 Press the ALT/[F3] (REPLACE MODE) buttons.

The REPLACE MODE menu appears, together with a REPLACE image window.

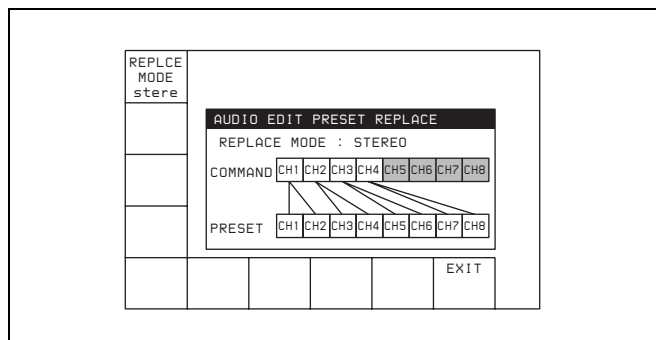

- 2 Press the [F1] (REPLACE MODE) button.

Each press of the button changes the setting in the order “normal → parallel → reverse → stereo”. At the same time, the image of the channels

corresponding to the command changes to reflect the selected setting.

- 3 Press the **[F10]** (EXIT) button.

This returns to the AUDIO menu screen.

You can also make this setting using the VTR SETUP menu item 311 “EDIT PRESET REPLACE MODE SELECT”.

See “4-6-9 External Device Analog Audio Edit Preset Command Replace Mode Selection (ANALOG AUDIO EDIT REPLACE)” (page 97) for information about settings for audio edit preset control of channels 9 to 12.

4-6-9 External Device Analog Audio Edit Preset Command Replace Mode Selection (ANALOG AUDIO EDIT REPLACE)

You can replace the channel settings for analog audio edit preset commands received from editors and other external devices. This function allows such devices to control channels 9 to 12 on this unit.

- 1 Press the ALT/**[F4]** (ANALOG REPLACE) buttons.

The ANALOG AUDIO EDIT REPLACE menu appears, together with a REPLACE image window.

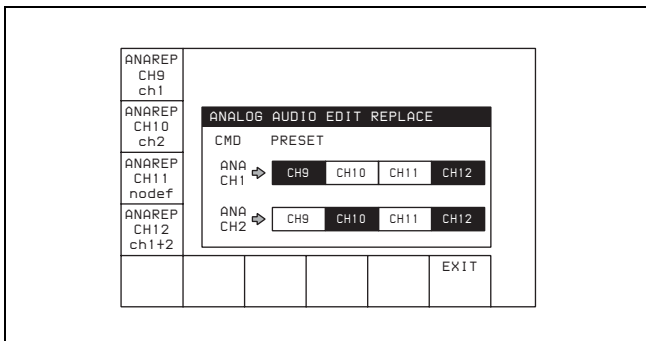

- 2 Use the **[F1]** (ANAREP CH9), **[F2]** (ANAREP CH10), **[F3]** (ANAREP CH11), **[F4]** (ANAREP CH12) buttons to specify whether to control channels 9 to 12 with edit preset commands for analog channels 1 and 2.

The image of the corresponding channels changes to reflect the settings.

- 3 Press the **[F10]** (EXIT) button.

This returns to the AUDIO menu screen.

You can also make this setting using the VTR SETUP menu item 312 “ANALOG AUDIO EDIT PRESET REPLACE”.

See “4-6-8 External Device Digital Audio Edit Preset Command Replace Mode Selection (AUDIO EDIT PRESET REPLACE)” (page 96) for information about audio edit preset control of channels 1 to 8.

4-6-10 PITCH GROUP Selection (PITCH CORRECTION GROUP SELECT)

When pitch correction is performed during program play and play at a different frequency (23.98 frame ↔ 24 frame, 23.98/24 frame ↔ 25 frame, 29.97 frame ↔ 30 frame), you can set up group relations between audio channels.

- 1 Press the ALT/**[F5]** (PITCH GROUP) buttons.

The PITCH CORRECTION GROUP SELECT menu appears, together with an image window of channels groups for pitch correction.

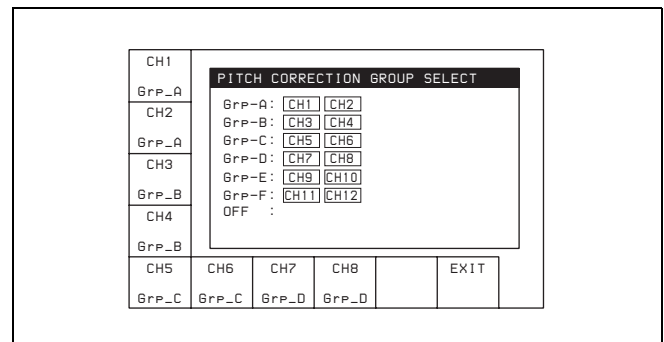

- 2 Use the **[F1]** (CH1) to **[F8]** (CH8) buttons and the ALT/**[F1]** (CH9) to ALT/**[F4]** (CH12) buttons to group channels (Group-A to F, OFF).

The image of channels belonging to each group changes to reflect the selections.

- 3 Press the **[F10]** (EXIT) button.

This returns to the AUDIO menu screen.

You can also make this setting using the VTR SETUP menu item 817 “PITCH CORRECTION GROUP select”.

4-7 SET UP Menu

In the SET UP menu, you can store and recall menu settings to and from the VTR memory banks and “Memory Stick”, register items to the PF menu, and set items in the VTR SETUP menu and PANEL SETUP menu.

To activate the SET UP menu
Press the SET UP button.

To change the SET UP menu page
Press the ALT button.

For details on storing and recalling data to or from the VTR memory banks or “Memory Stick”, and registering items to the PF menus, see “4-1 Registering and Storing Menu Settings” on page 38.

“▼” indicates that more than one menu page exists.

UTR BANK ▼	[F1]UTR BANK: Copy data between current setup and 8 banks.				
MEMORY CARD ▼	[F2]MEMORY CARD: Copy data between VTR and memory card.				
PF ASSIGN ▼	[F4]PF1&2 ASSIGN: Assign PF1/PF2 menu function keys.				
PANEL SETUP ▼	UTR SETUP ▼				

Button	Indication	Function	Settings
[F1]	VTR BANK	See “4-1-4 VTR Memory Bank Function” on page 40.	
[F2]	MEMORY CARD	See “4-1-5 “Memory Stick” Operations” on page 42.	
[F4]	PF ASSIGN	See “4-1-3 Registering Items to the VTR SETUP Menu” on page 39.	
[F5]	PANEL SETUP	See “4-7-2 PANEL SETUP Menu” on page 101.	
[F6]	VTR SETUP	See “4-7-1 VTR SETUP Menu” on page 99.	
ALT/[F1]	DEFAULT VTR BANK	See “4-1-10 Saving and Recalling DEFAULT Settings on a Bank” on page 49.	
ALT/[F2]	DEFAULT MEMORY CARD	See “4-1-11 Saving and Recalling DEFAULT Settings in a “Memory Stick”” on page 49.	
ALT/[F7]	REMOTE NET	Selects access from the ETHERNET connector.	on, off
ALT/[F8]	REMOTE 9-PIN	Selects remote operation using a device connected to the REMOTE 1-IN(9P) or REMOTE 1-I/O(9P) connector.	on, off
ALT/[F9]	REMOTE 50-PIN	Selects remote operation using a device connected to the REMOTE 2 PARALLEL I/O(50P) connector.	on, off

Selecting remote operation mode

When operating the VTR with an external device, set the ALT/[F7] (REMOTE NET) buttons, ALT/[F8] (REMOTE 9-PIN) buttons or ALT/[F9] (REMOTE 50-PIN) buttons to “on”.

When the ALT/[F7] (REMOTE NET) buttons are set to “on”

You can operate the VTR from a computer or similar through the network to which the ETHERNET connector is connected.

When the ALT/[F8] (REMOTE 9-PIN) buttons are set to “on”

You can operate the VTR with a device connected to the REMOTE 1-IN(9P) or REMOTE 1-I/O(9P) connector.

When the ALT/[F9] (REMOTE 50-PIN) buttons are set to “on”

You can operate the VTR with a device connected to the REMOTE 2 PARALLEL I/O(50P) connector.

Note

When operating the VTR through an external device with the ALT/[F8] or ALT/[F9] buttons set to “on”, all of the tape operation and editing buttons are disabled, with the exception of the STOP and EJECT buttons. You may also set the VTR so that all buttons are enabled or disabled. Perform this setting using the VTR SETUP menu item 008 “LOCAL FUNCTION ENABLE”. You cannot, however, disable the menu and remote operation mode selection buttons.

4-7-1 VTR SETUP Menu

All menu items required for setting up the VTR operating conditions are displayed in the scrollable VTR SETUP menu.

For HOME, TC, VIDEO, AUDIO, PF1, and PF2, including the screens displayed by pressing the ALT button, you can register about 120 menu items.

For details of the PF assign menu, see “4-1-3 Registering Items to the VTR SETUP Menu” on page 39.

To activate the VTR SETUP menu

Press the SET UP button, then press the [F6] (VTR SETUP) button.

For details on the VTR SETUP menu items, see the Appendix “Menu List” on page 142.

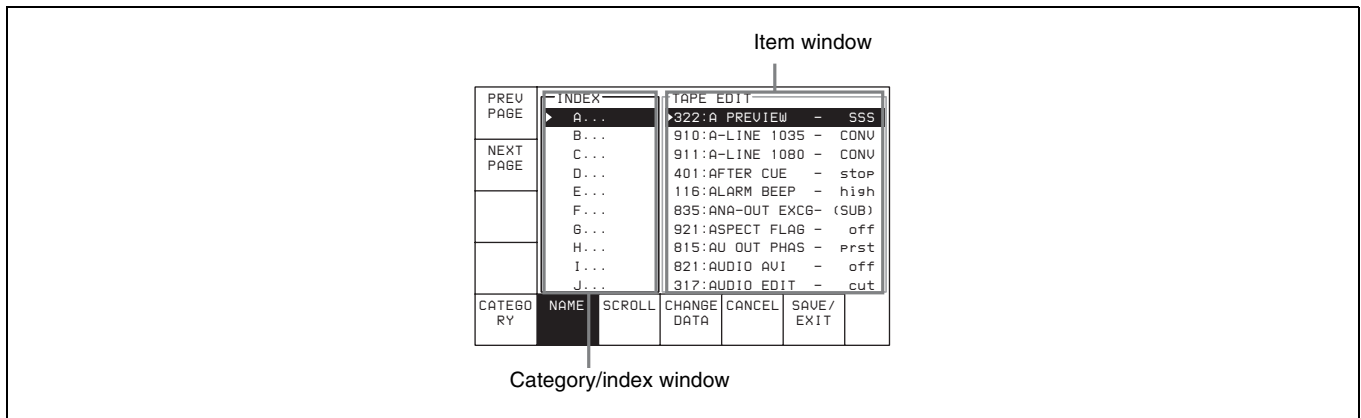

Button	Indication	Function
[F1]	PREV PAGE	Moves to the beginning of the previous category.
[F2]	NEXT PAGE	Moves to the beginning of the next category.
[F5]	CATEGORY	Display by category
[F6]	NAME	Display in alphabetical order
[F7]	SCROLL	Scrolling display of all menus
[F8]	CHANGE DATA	Changes the setting.
[F9]	CANCEL	Cancels the setting operation.
[F10]	SAVE/EXIT	Sets the value and exits the VTR SETUP menu.

Scrolling items in the VTR SETUP menu

Press the \uparrow and \downarrow buttons to scroll the items in the VTR SETUP menu.

To search the menu by category

Items in the VTR SETUP menu are divided into categories according to type of settings they perform.

Menu number	Category
Nos. 001 to ...	Items related to VTR operations
Nos. 101 to ...	Items related to operation panels
Nos. 201 to ...	Items related to remote interface
Nos. 301 to ...	Items related to editing
Nos. 401 to ...	Items related to prerolling
Nos. 501 to ...	Items related to recording protection
Nos. 601 to ...	Items related to the time code
Nos. 701 to ...	Items related to the video control
Nos. 801 to ...	Items related to the audio control
Nos. 901 to ...	Items related to digital process
Nos. A01 to ...	Items related to pulldown control
Nos. T01 to ...	Other

To change the menu display

Press any of the following buttons, to change the menu display.

- [F5] (CATEGORY) button:** Display the menus by category
- [F6] (NAME) button:** Display all menus in alphabetical order
- [F7] (SCROLL) button:** Display all menus in numerical order

Changing settings

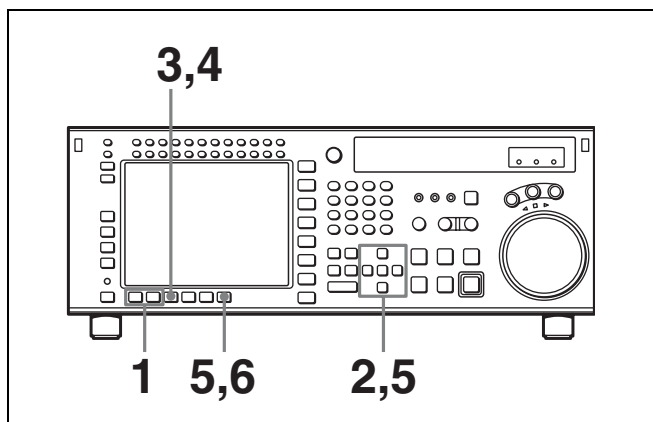

- 1** Press one of the **[F5]** (CATEGORY), **[F6]** (NAME), and **[F7]** (SCROLL) buttons.

This changes the menu display.

To change the category

Do one of the following:

- Press the \leftarrow button to make the categories window active, and select the category with the \uparrow and \downarrow buttons.
- Press the \rightarrow button to make the item window active, and press the **[F1]** (PREV PAGE) or **[F2]** (NEXT PAGE) button.

- 2** Press the \rightarrow button to make the item window active, then use the cursor \uparrow and \downarrow button, or the MULTI CONTROL knob, to align the cursor with the item to be changed.

To speed up cursor movement

Hold down the SFT button, and press the cursor \uparrow and \downarrow button.

- 3** Press the **[F8]** (CHANGE DATA) button or the cursor \rightarrow button.

A window for changing the setting value appears.

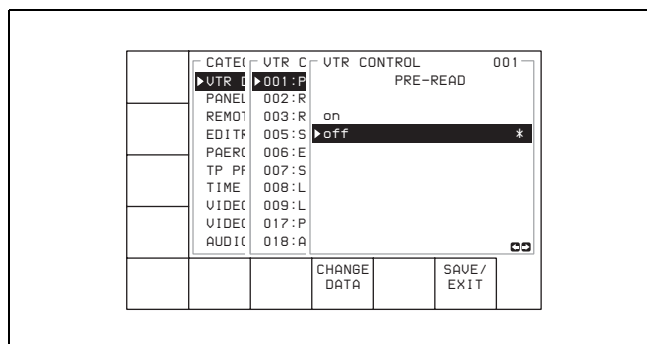

- 4** With the **[F8]** (CHANGE DATA) button, or the cursor \uparrow and \downarrow button, or the MULTI CONTROL knob, select the setting value.

When subitems are displayed, use the cursor \uparrow and \downarrow button, or the MULTI CONTROL knob to select the subitem to be changed, then press the **[F8]** (CHANGE DATA) button repeatedly.

To return to the DEFAULT values, press the center cursor button or the MULTI CONTROL knob.

- 5** Press the **[F10]** (SAVE/EXIT) button or the cursor \leftarrow button.

This saves the change, and closes the window.

About the unit's behavior when the MULTI CONTROL knob is pressed

You can set item 132 "KNOB MODE" in the VTR SETUP menu to "move window" to select moving between windows as the action when the knob is pressed.

- 6** To continue with changing the settings, repeat steps 1 to 5.
- 7** Press the **[F10]** (SAVE/EXIT) button.

This saves all the changes, and returns to the SET UP menu screen.

To check the items with changed settings

In VTR SETUP menu item 131 “CHANGED MENU HIGHLIGHT”, set ITEM SETTING to “on”.

Items for which the setting values are different from the DEFAULT values appear in the VTR SETUP screen in yellow.

To change the DEFAULT values in a menu item

- 1** Use the cursor \rightarrow button to make the item window active, then with the cursor \uparrow and \downarrow buttons or the MULTI CONTROL knob, move the cursor to the item to be changed.

- 2** Press the **[F7]** (CHANGE DATA) button or the cursor \rightarrow button.

This opens a window for changing the setting.

For a sub item, further press the **[F7]** (CHANGE DATA) button or the cursor \rightarrow button, to open the window for changing the setting.

- 3** With the **[F7]** (CHANGE DATA) button, the cursor \uparrow or \downarrow button, or the MULTI CONTROL knob, change the setting.
- 4** Holding down the SET and ENTRY buttons at the same time, press the center cursor button.

This saves the current settings as new DEFAULT values for CURRENT DEFAULT.

The asterisks “*” indicating the DEFAULT values move.

Note

If you press the center cursor button first, the setting values return to the PRESET values before CURRENT DEFAULT is overwritten, and it is not possible to change DEFAULT correctly.

To return the DEFAULT values to the factory default PRESET values

Holding down the CLR and ENTRY buttons at the same time, press the center cursor button.

This saves the factory default PRESET values as the DEFAULT values for CURRENT DEFAULT.

- 5** Reset the current setting values if necessary, then press the **[F10]** (SAVE/EXIT) button.

You can save the changed CURRENT DEFAULT data set in DEFAULT VTR BANK or a “Memory Stick”.

For details, see see “4-1-10 Saving and Recalling DEFAULT Settings on a Bank” on page 49 and see “4-1-11 Saving and Recalling DEFAULT Settings in a “Memory Stick”” on page 49.

To check the items for which DEFAULT values have been changed

In VTR SETUP menu item 131 “CHANGED MENU HIGHLIGHT”, set DEFAULT SETTING to “on”.

Items for which the DEFAULT values are different from the factory setting values (FACTORY PRESET) values have the item number (or item name for a subitem) in the VTR SETUP screen shown in yellow.

4-7-2 PANEL SETUP Menu

The PANEL SETUP menu is used to set the operation conditions of the upper and lower control panels.

To activate the PANEL SETUP menu

Press the SET UP button, then press the **[F5]** (PANEL SETUP) button.

KEYINH off	PLAY LOCK				
	KEY BEEP off	ALARM BEEP high	SCREEN SAVER 10min	SCREEN SAVER S	EXIT

Button	Indication	Function	Settings
[F1]	KEYINH	Disables all button operations.	on, off
[F6]	KEY BEEP	Sets the keyboard sound.	high, mid, low, off
[F7]	ALARM BEEP	Sets the alarm.	high, mid, low, off
[F8]	SCREEN SAVER	Sets the color display screen-saver.	3min, 10min, 60min, off
[F9]	SCREEN SAVER S	Sets the information display screen-saver.	on, off
[F10]	EXIT	Returns to the PANEL SETUP menu.	

Disabling button operations on the upper/lower control panel

Set the [F1] (KEYINH) button to “on”.

Setting the confirmatory beep after button operations

Press the [F6] (KEY BEEP) button repeatedly.

high: loud confirmatory beep

mid: confirmatory beep

low: quiet confirmatory beep

off: no confirmatory beep

Setting the alarm sound when an error occurs

Press the [F7] (ALARM BEEP) button repeatedly.

high: loud alarm sound

mid: alarm sound

low: quiet alarm sound

off: no alarm sound

Setting the time until the color display screen saver is activated

Press the [F8] (SCREEN SAVER) button repeatedly.

3min: The screen saver is activated 3 minutes after the last button operation.

10min: The screen saver is activated 10 minutes after the last button operation.

60min: The screen saver is activated 60 minutes after the last button operation.

off: The screen saver is not activated.

Setting the information display screen saver

Press the [F9] (SCREEN SAVER S) button.

on: The screen display is periodically switched between normal video and reverse video.

off: The screen saver is not activated.

5-1 Preparing for Recording

5-1-1 Setting Switches and Menus

Before recording, set the switches and menus as shown in the diagram below.

For details, see the pages indicated in the parentheses.

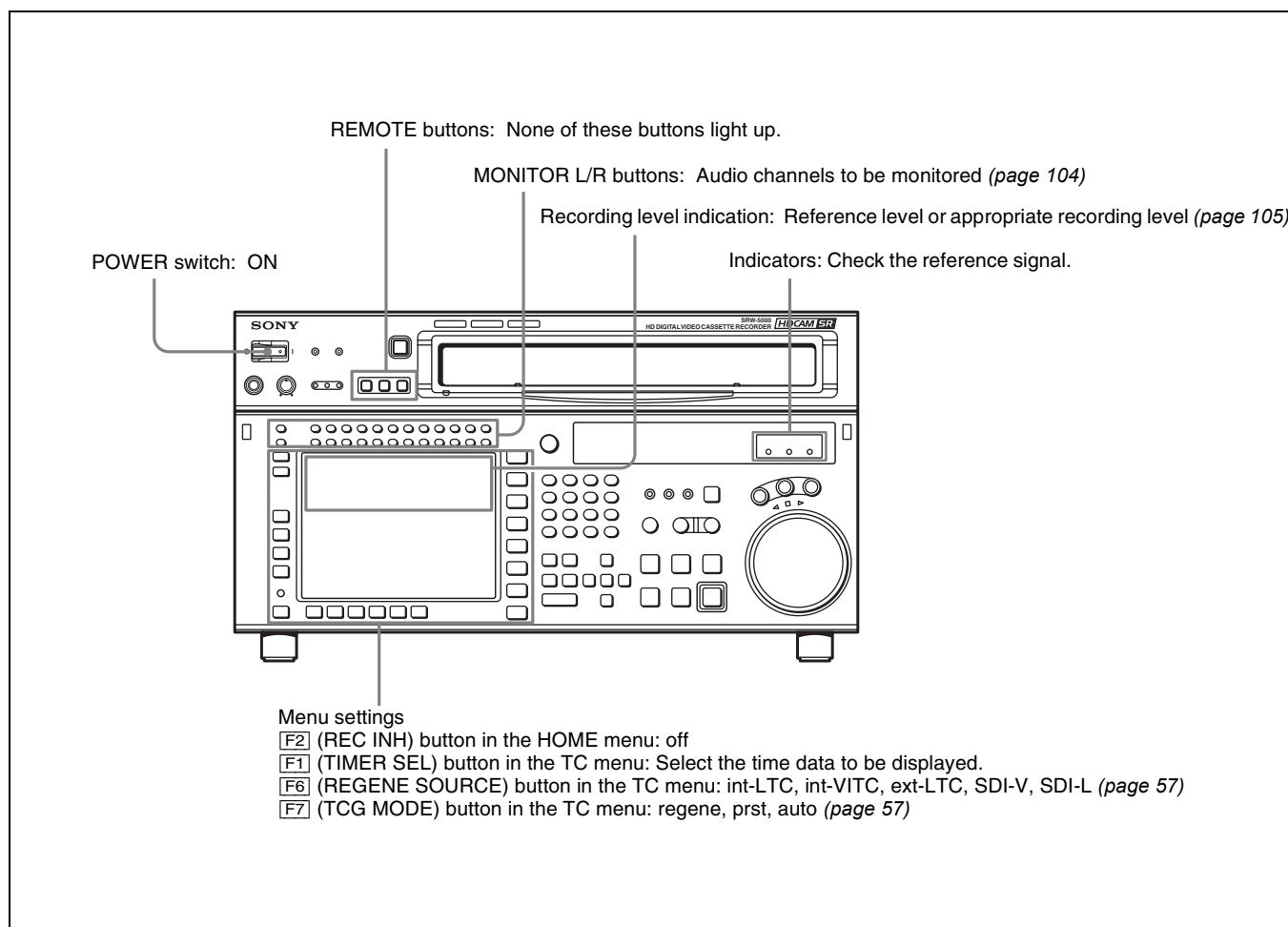

5-1-2 Selecting Audio Signals

This section describes how to select the audio signals for input and monitoring.

Selecting the audio input signals

Proceed as follows to select the audio input signal and channels.

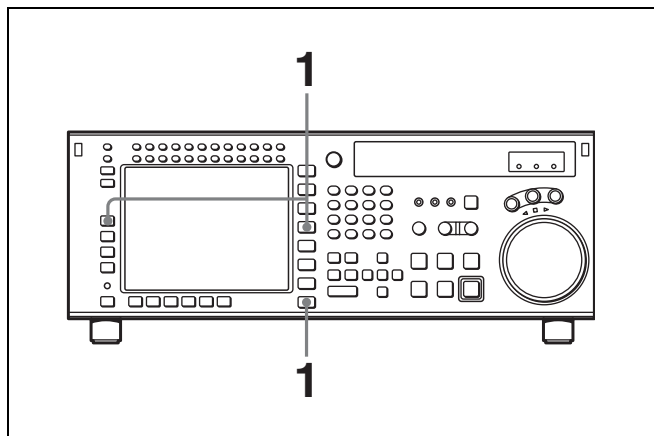

- 1 Press the AUDIO button, and in the AUDIO menu press the [F1] (AUDIO IN) button, to access the AUDIO INPUT menu.
- 2 Make the audio input signal settings for each channel.
SDI: audio signal input from the HD SDI INPUT A/B connector
AES/EBU: audio signal input from the DIGITAL I/O (AES/EBU) connector

To make settings for individual channels with the F buttons

By pressing any of the [F1] (A-IN CH1) to [F8] (A-IN CH8) buttons in the AUDIO INPUT menu, and the [F1] (A-IN CH9) to [F4] (A-IN CH12) buttons in the ALT+AUDIO screen obtained by pressing the ALT button, you can select the type of input signal for each channel.

To make input signal selections for individual channels with the numeric buttons

- 1 Press the cursor ← or → button, to align the cursor with the channel for which you want to make the selection.
- 2 Press the cursor ↑ or ↓ button, to select the signal.

To return to the default settings

Press the cursor center button.

To select the same input signal simultaneously on all twelve channels

Press the [F9] (A-IN ALL) button.

This changes the input signal simultaneously on all twelve channels.

You can also make this setting using the VTR SETUP menu item 830 “AUDIO INPUT SELECT”.

Selecting audio signals to be monitored

With the MONITOR L or R buttons at the upper left of the control panel, switch the audio signal output from the PHONES jack and MONITOR OUTPUT L/R connectors as follows.

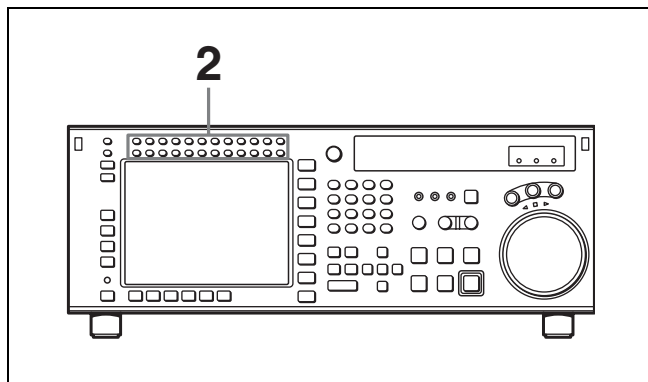

- 1 Check the audio level display area in the color display, and make sure that the unit is not in the REC LEVEL/PB LEVEL setting state (with red or blue vertical lines appearing on the left and right of the audio level meter).

The channels for which the signals are currently being monitored are shown by reverse video characters “L” and “R” below the audio level meter.
- 2 Press the buttons corresponding to each channel, to light the L/R reverse video indications below the audio level meter, and specify channels 1 to 12 with the MONITOR L or R button (both L and R can also be specified).

This setting can also be made using the VTR SETUP menu items 807 “AUDIO MONITOR-L select” and 808 “AUDIO MONITOR-R select”.

To adjust the audio output level of the PHONES jack

Rotate the PHONES level control on the upper control panel.

Selecting non-audio data as the audio input signal

Do the procedure below to select non-audio data such as a Dolby¹⁾ E or Dolby Digital (AC-3²⁾) signal as the audio input signal. Use the VTR SETUP menu item 831 “NON AUDIO SELECT” to select the audio input signal.

1) Dolby is a trademark of Dolby Laboratories.

2) AC-3 is a trademark of Dolby Laboratories.

Notes

The following processes are performed for the selected channels.

- For the input signal, the setting of the VTR SETUP menu item 831 “NON AUDIO SELECT” takes precedence over that of the menu item 830 “AUDIO INPUT SELECT”.
- For the audio level meters, the whole region lights. Also, below the input signal display, the word “DATA” appears in white.
- The analog audio outputs (main line/monitor/headphones) are muted.
- The audio recording level adjustment itself is possible for the channel for which “NON AUDIO” is selected, but the setting does not affect the recording or playback of DATA.
- Non-audio input channels are selected in stereo pairs.

5-1-3 Adjusting the Recording Level

Adjusting the Recording Level

- 1 Press the REC LEVEL button at the upper left of the control panel to enter the REC LEVEL adjustment mode.

A vertical red line appears at the left of the audio level meter for each channel, indicating the REC LEVEL adjustment mode.

Note

The adjustment cannot be made with the VIDEO menu and the VTR SETUP menu.

- 2 Press the button for the channel for which you want to carry out the adjustment (common with MONITOR L), to make the channel active.

An orange border appears around the audio level meter, indicating that it is active.

- 3 Use the cursor buttons to make the adjustment.

To escape from the REC LEVEL adjustment mode

Press the REC LEVEL mode button at the upper left of the control panel once more. The vertical red line at the left of the audio level meter for each channel disappears or turns white.

To record at the reference level

In the REC LEVEL adjustment mode, make the channel active, then press the MULTI CONTROL knob. The setting becomes the reference value. Press once more to return to the immediately previous value. Press once more again to return to the reference value. You can also return to the reference value with the cursor center button. When you exit the REC LEVEL adjustment mode, a vertical white line on the left of the audio level meter is not displayed.

To record with manual adjustment

In the REC LEVEL adjustment mode, make the channel active, then at the mean volume make the adjustment with the MULTI CONTROL knob or cursor \uparrow and \downarrow buttons so that the audio level meter is close to the reference 0 dB level. When you exit the REC LEVEL adjustment mode, the vertical white line on the left of the audio level meter and a horizontal red line indicating the setting are displayed, indicating that the recording level is subject to manual adjustment.

You can also carry out the recording level adjustment using the VTR SETUP menu item 832 “AUDIO REC LEVEL”.

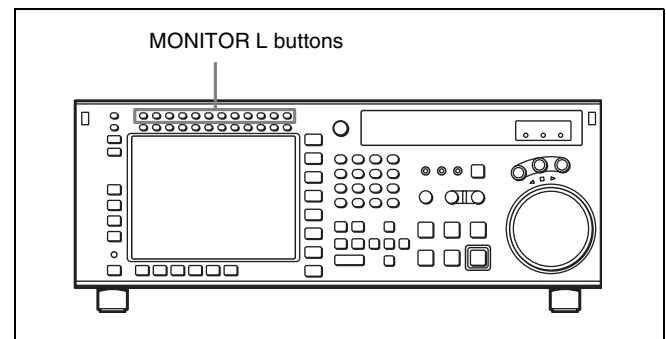

Selecting the display range of the audio level meters

You can switch the range of audio level meter display by pressing the FULL/FINE button on the lower control panel.

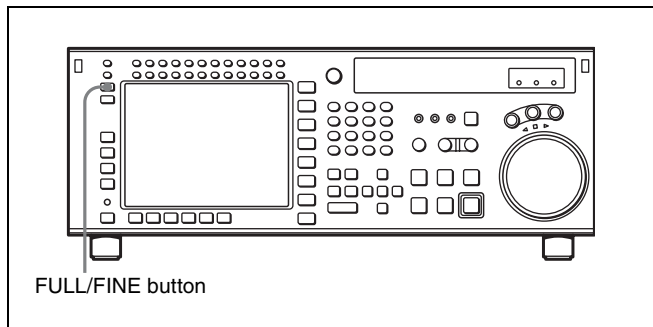

FULL mode: The meter range is -60 to 0 dB or -40 to $+20$ dB.

FINE mode: The meter scale is enlarged, and the signal level is indicated in 0.25 dB steps, with the reference marker indicated in the middle of each meter.

The display range of the audio level meters in FULL mode can be set using the VTR SETUP menu item 814 "LEVEL METER SCALE".

5-1-4 Simultaneously Monitoring Playback of Video and Audio Signals Being Recorded

Monitoring signals being recorded

Using the VTR SETUP menu item 017 "PB/EE SELECT MENU", you can make a setting so that the audio and video signals currently being recorded are simultaneously checked.

To check video and audio signals during recording

Set the sub item "REC" of the VTR SETUP menu item 017 "PB/EE SELECT MENU" to "PB/PB". Both audio and video playback signals are output.

5-1-5 Audio Level Meter Display Modes

The audio level meter display changes for each mode depending on the current system recording mode settings and the type of cassette in use.

SRW-5000:

REC format	Cassette used	EE	PB	EJECT
HDCAM-SR	HDCAM-SR	12ch	12ch	12ch
	HDCAM/D-BETACAM		4ch+CUE	

SRW-5500:

REC format	Cassette used	EE	PB	EJECT
HDCAM-SR	HDCAM-SR	12ch	12ch	12ch
	HDCAM/D-BETACAM		4ch+CUE	
HDCAM	HDCAM-SR	4ch+CUE	12ch	4ch+CUE
	HDCAM/D-BETACAM		4ch+CUE	
AUTO	HDCAM-SR	12ch	12ch	12ch
	HDCAM/D-BETACAM	4ch+CUE	4ch+CUE	

5-2 Recording

To record, follow the procedure below.

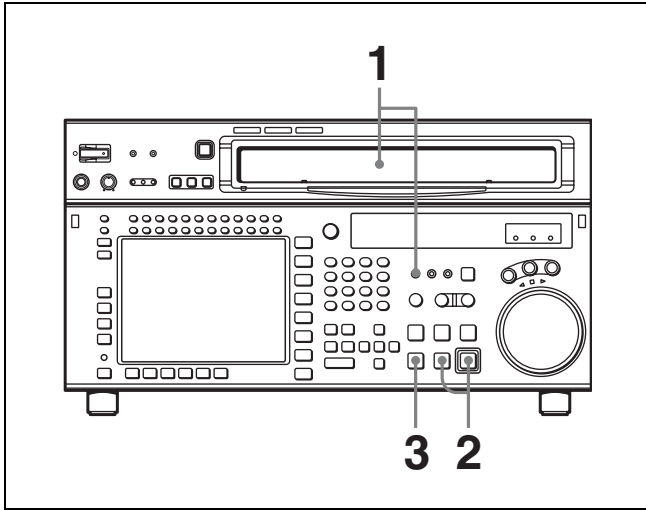

- 1** Check that the REC INHIBIT indicator is off, then insert a cassette.

For details on inserting a cassette, see “3-3-2 Inserting and Ejecting Cassettes” on page 35.

- 2** Press the PLAY button while holding down the REC/EDIT button.

Recording starts and the SERVO indicator lights up to indicate that the servo is locked.

- 3** Press the STOP button to stop recording.

If the recording continues to the end of the tape

If the VTR SETUP menu item 407 “AUTO REWIND” is set to “on”, then the tape automatically rewinds to the beginning and stops.

5-3 Preparing for Playback

5-3-1 Setting Switches and Menus

Before starting playback, set the switches and menus as shown in the diagram below.

For details, see the pages indicated in the parentheses.

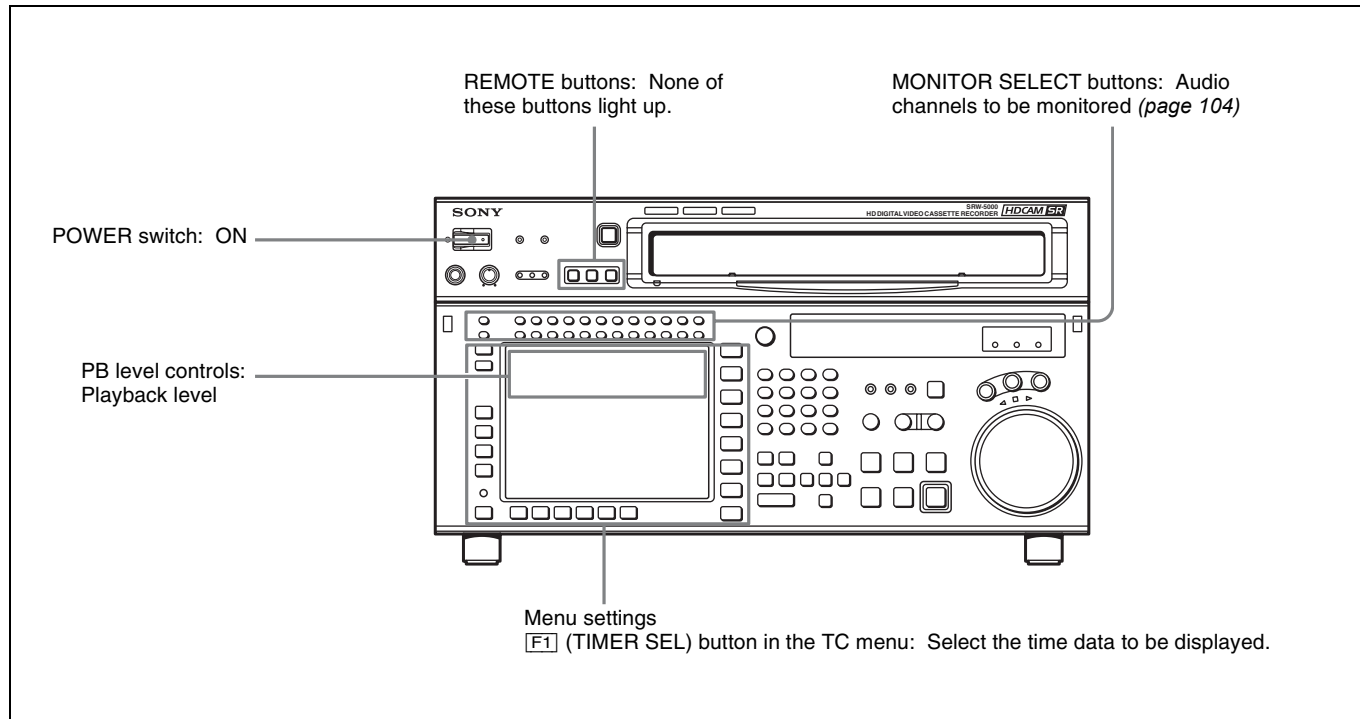

5-3-2 Adjusting the Audio Playback Level

- 1 Press the PB LEVEL button at the upper left of the control panel to enter the PB LEVEL adjustment mode.

A vertical blue line appears at the right of the audio level meter for each channel, indicating the PB LEVEL adjustment mode.

- 2 Press the button for the channel for which you want to carry out the adjustment (common with MONITOR R), to make the channel active.

An orange border appears around the audio level meter, indicating that it is active.

- 3 Make the adjustment, using the MULTI CONTROL knob or cursor buttons.

To escape from the PB LEVEL adjustment mode
Press the PB LEVEL button at the upper left of the control panel once more. The vertical blue line at the right of the audio level meter for each channel disappears or turns white.

To output at the preset level (for a level recorded at reference 0 dB, outputting at +4 dBm)

In the PB LEVEL adjustment mode, make the channel active, then press the MULTI CONTROL knob. The setting becomes the preset value. Press once more to return to the immediately previous value. Pressing once more again to return to the preset value. You can also return to the preset value with the cursor center button. When you exit the PB LEVEL adjustment mode, a vertical white line on the right of the audio level meter is not displayed.

For details on changing the factory-set reference output level, refer to the Installation Manual.

To adjust the audio playback level manually

In the PB LEVEL adjustment mode, make the channel active, then adjust to the desired volume with the MULTI CONTROL knob or cursor \uparrow and \downarrow buttons. When you exit the PB LEVEL adjustment mode, the vertical white line on the right of the audio level meter and a horizontal white line indicating the setting are displayed, indicating that the playback level is subject to manual adjustment.

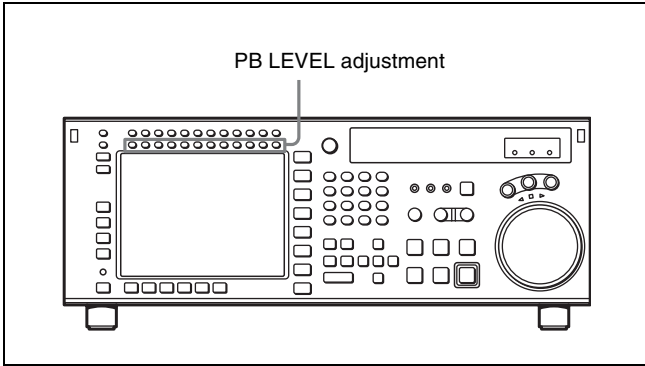

You can also carry out the playing level adjustment using the VTR SETUP menu item 833 "AUDIO PB LEVEL".

5-3-3 Selecting the HD-SD Conversion Mode

Select the conversion mode using the VTR SETUP menu item 930 "DOWNCONVERTER MODE".

- Edge crop mode (CROP)

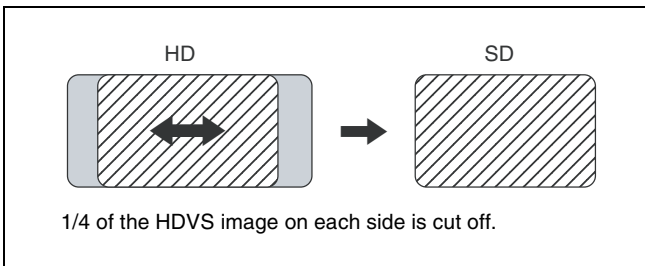

Horizontal adjustment of the edge cropping

Use the VTR SETUP menu item 932 "H CROP POSITION (DC)".

- Letter box mode (LETTER BOX)

When the letter box mode is selected, you can select one of the following three conversion methods using the VTR SETUP menu item 931 "LETTER BOX MODE (DC)".

When 16:9 is selected

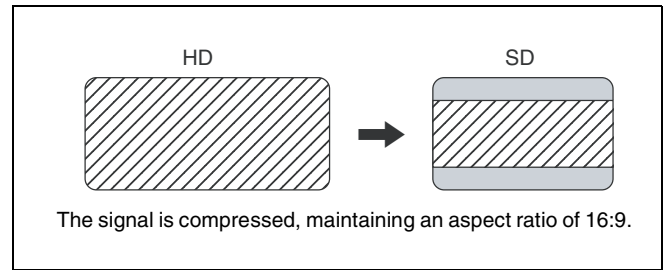

When 14:9 is selected

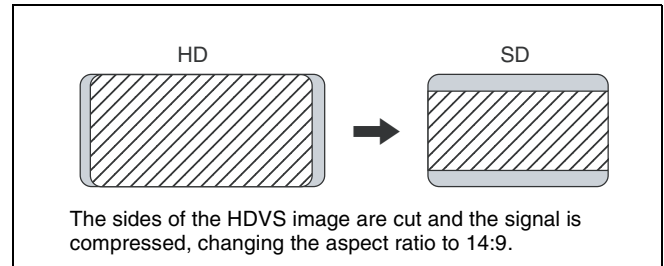

When 13:9 is selected

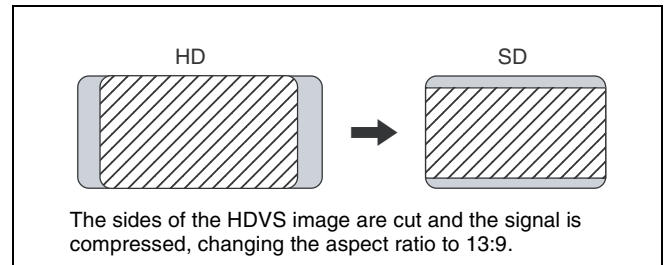

- Squeeze mode (SQUEEZE)

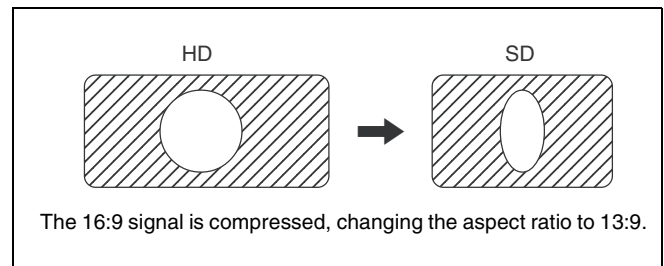

5-4 Playback

There are four types of playback:

- Normal-speed playback
- Jog/Shuttle/Variable mode playback
- Capstan override playback
- DMC (Dynamic Motion Control) playback

5-4-1 Normal-Speed Playback

Follow the procedure below to play back at normal speed.

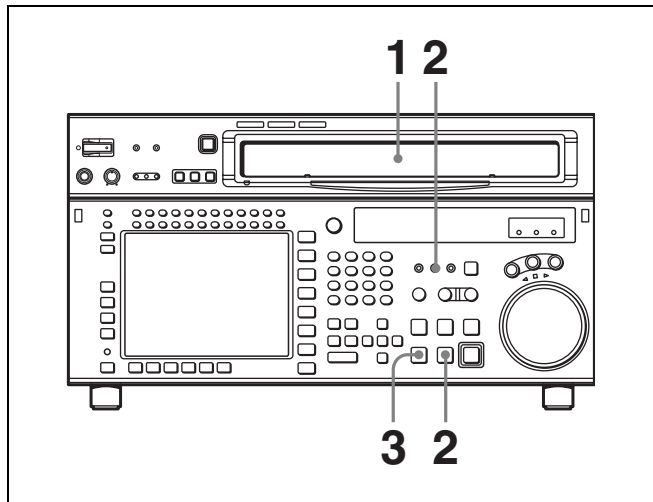

1 Insert a cassette.

For details on inserting a cassette, see “3-3-2 Inserting and Ejecting Cassettes” on page 35.

2 Press the PLAY button.

Playback starts and the SERVO indicator lights up to indicate that the servo is locked.

3 Press the STOP button to stop playback.

If playback continues to the end of the tape

If the VTR SETUP menu item 407 “AUTO REWIND” is set to “on”, then the tape automatically rewinds to the beginning and stops.

5-4-2 Variable Speed Playback

In Jog/Shuttle/Variable modes, you can change the playback speed as follows:

Jog mode: The playback speed corresponds to the rotational speed of the search dial, ranging from -1 to +1 or -2 to +2 times normal playback speed (for Digital Betacam playback, ± 3 times normal speed).

(The speed setting can be changed using the VTR SETUP menu item 107 “JOG DIAL RESPONSE”.)

Shuttle mode: The playback speed corresponds to the angle of rotation of the search dial. The playback speed is different depending on the frame frequency of the unit. The search dial clicks at the positions for still-picture and ± 10 times normal speed playback.

Frame frequency	Playback speed (HDCAM-SR)	Playback speed (HDCAM)	Playback speed (D-BETACAM)
23.98/24 Hz	Ranging from -50 to +50	Ranging from -60 to +60	
25 Hz	Ranging from -48 to +48	Ranging from -58 to +58	Ranging from -58 to +58
29.97/30 Hz	Ranging from -40 to +40	Ranging from -50 to +50	Ranging from -50 to +50

Variable mode: Playback speed is -1 times normal speed when the search dial is rotated fully counterclockwise, and +2 times normal speed (for Digital Betacam playback, -1 to +3 times normal speed) when rotated clockwise.

Jog mode playback

Follow the procedure below to play back in jog mode.

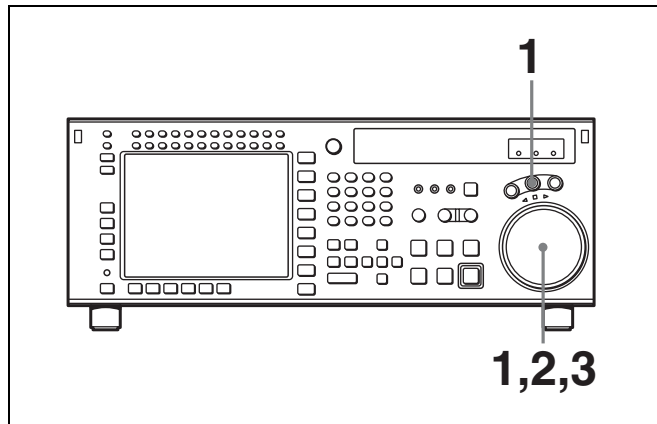

1 Press the JOG button, turning it on.

The VTR enters still-picture mode.

2 Rotate the search dial in the desired playback direction and to the desired angle.

The tape is played back slowly, at a speed corresponding to the rotational speed of the search dial. A direction indicator (◀ or ▶) lights up to indicate the direction of playback.

3 Stop rotating the search dial to stop jog mode playback.

The indicator lights up.

For details on switching the search dial functions, refer to the Maintenance Manual Volume 1.

Shuttle mode playback

Follow the procedure below to play back in shuttle mode.

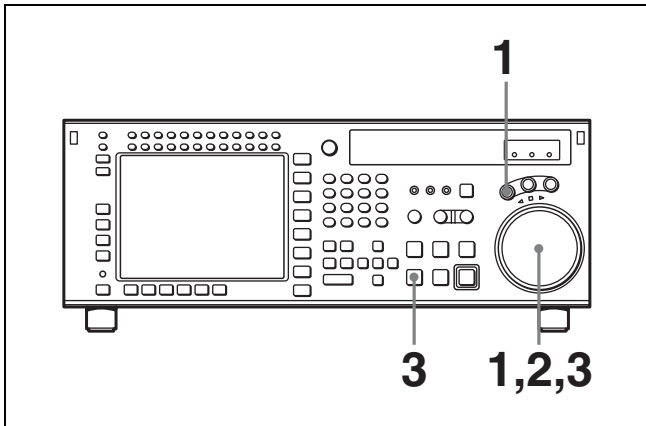

- 1 Press the SHUTTLE button, turning it on.
The VTR enters still-picture mode.
- 2 Rotate the search dial in the desired playback direction and set the angle of rotation as required to obtain the desired playback speed.

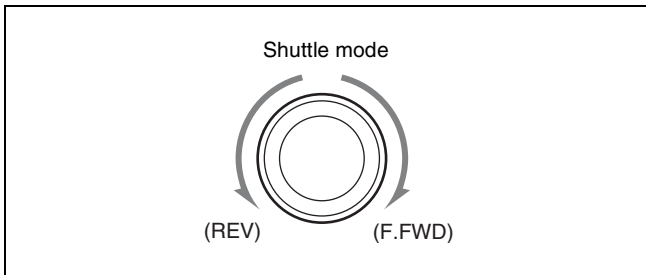

The tape is played back at a speed that corresponds to the angle of the search dial. A direction indicator (◀ or ▶) lights up to indicate the direction of playback. The search dial clicks at the positions for still-picture and ± 10 times normal-speed playback.

- 3 Set the search dial to center position for still-picture, or press the STOP button to stop shuttle mode playback.

To return to normal-speed playback

Press the PLAY button.

Note

The audio signal output status is specified by the following settings of the VTR SETUP menu item 017 "PB/EE SELECT MENU".

EE: The input audio is always output.

MU: The audio output is always muted.

PB: The playback signal is always output.

Variable mode playback

Follow the procedure below to play back in variable mode.

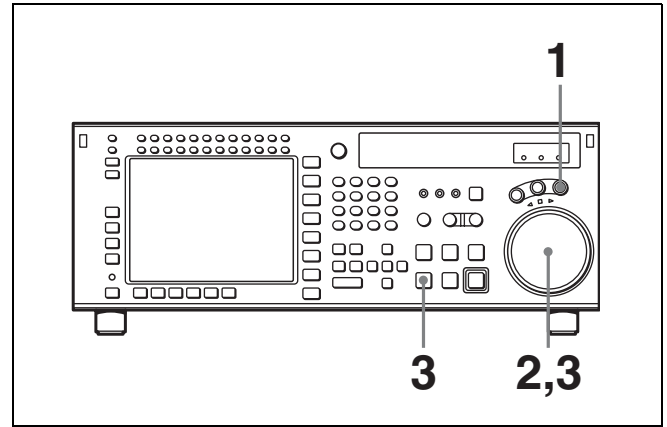

- 1 Press the VAR button, turning it on.
The VTR enters VAR mode.
- 2 Rotate the search dial in the desired playback direction and set the angle of rotation as required to achieve the desired playback speed.

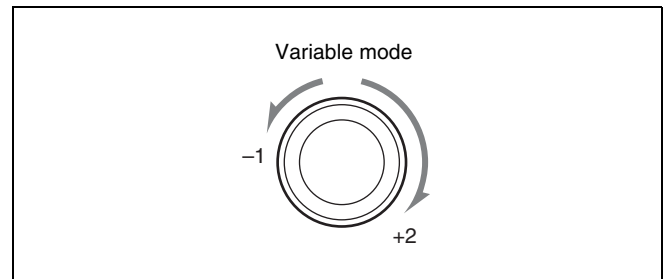

The tape is played back at a speed that corresponds to the angle of the search dial. A direction indicator (◀ or ▶) lights up to indicate the direction of playback. The search dial clicks at the positions for still-picture and normal-speed playback.

- 3 Set the search dial to center position for still-picture, or press the STOP button to stop variable mode playback.

To return to normal-speed playback

Press the PLAY button.

To alternate between normal-speed playback and variable mode playback

After you have set the search dial to the angle that corresponds to the desired playback speed, pressing the PLAY button or VAR button selects normal-speed playback or variable mode playback, respectively. To stop or start variable mode playback, press the STOP button or VAR button, respectively.

The VTR is factory set so that pressing the JOG, SHUTTLE, or VAR button is required in order to enter variable-speed playback mode. To change this setting, use

the VTR SETUP menu item 101 “SELECTION FOR SEARCH DIAL ENABLE”.

5-4-3 Capstan Override Playback

When playing back the same program on two VTRs, you can adjust the playback phases of the two VTRs so that they are synchronized.

There are two ways to make this adjustment:

- (A) Using the search dial
- (B) Using the +/- buttons

Note

When using method (A), change the system setup so that jog/shuttle mode playback is inhibited even when the search dial is rotated. Doing so prevents the VTR from accidentally entering jog/shuttle mode during capstan override playback.

Set the VTR SETUP menu item 101 “SELECTION FOR SEARCH DIAL ENABLE” to “via search key”.

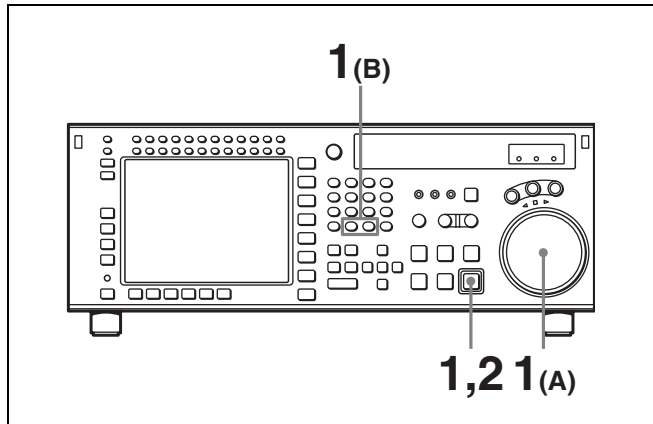

- 1** Use either method (A) or (B).
 - (A) Rotate the search dial while holding down the PLAY button to adjust the playback speed. The adjustment range is $\pm 15\%$ (in steps of 1%) of the normal playback speed.
 - (B) Press the + or – button while holding down the PLAY button to adjust the playback speed. Every time the + or – button is pressed, the speed changes by 1 frame.

During playback at increased or decreased speed, the SERVO indicator goes off since the servo is not locked (capstan override).

- 2** Release the PLAY button after you have finished adjusting the phase.

The VTR returns to normal-speed playback and the SERVO indicator lights up.

5-4-4 DMC Playback

Overview of DMC playback

DMC (Dynamic Motion Control) playback allows you to vary the playback speed in variable mode (in the DT playback range from –1 to +2 times normal speed) for certain sections of the tape, then store the specified speed in memory for later playback.

For example, during a live broadcast of a sporting event, you can set the start and end points of important scenes while recording, and immediately play back and broadcast those scenes using DMC playback.

Storing playback speeds in memory

Follow the procedure below to store DMC playback speeds in memory.

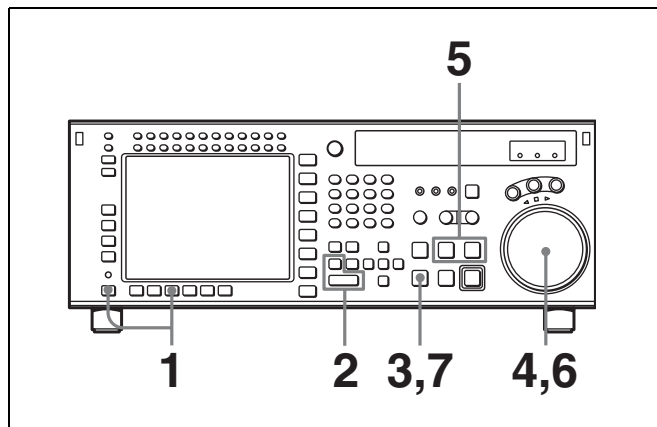

- 1** In the HOME menu, press the ALT/[F7] (DMC) buttons to light up DMC on the display.
- 2** Set a start point during recording or on a previously recorded tape by simultaneously pressing the ENTRY button and the IN button.
- 3** Press the STOP button to enter stop mode.
- 4** Rotate the search dial to select the initial playback speed.

The selected speeds are shown in the time data display window in the menu display.

Note

If the VTR SETUP menu item 101 “SELECTION FOR SEARCH DIAL ENABLE” is set to “dial direct”, initial speed settings cannot be made. Change the setting of this menu item to “via search key”.

- 5** Press the PREROLL button and PREVIEW/REVIEW button simultaneously.

The tape is prerolled and played back at the initial speed from the preroll point to the speed variation start point. The moment the tape passes the speed variation start point, the MEMORY indicator in the display starts flashing.

(The ■ indicator appears in the time data display window, indicating that tape speed memorization in DMC mode is active.)

- 6** Rotate the search dial to the position for the desired playback speed.

The speed variation is stored in memory while the MEMORY indicator is flashing.

- 7** Press the STOP button to stop the tape.

If the MEMORY indicator flashes before the tape reaches the speed variation end point

Memory has been exceeded and the VTR cannot store any more data for playback speed variations.

Notes on the ■ indicator and the MEMORY indicator

The ■ indicator shows that the tape speed memorization in DMC mode is taking place.

The MEMORY indicator flashes during playback speed memorization, and goes out when memorization of the playback speed has been completed.

Performing DMC playback

There are two methods of starting DMC playback.

- Starting playback at the on-air cue from the on-air start point
- Starting playback immediately after prerolling

Note

To avoid operation errors, we recommend that you use the VTR alone when performing DMC playback.

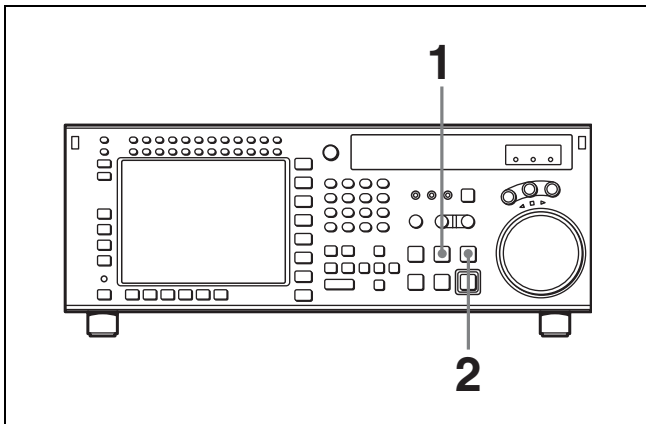

To start playback at the on-air cue from the on-air start point

- 1** Press the PREROLL button, turning it on.

The tape is cued up to the on-air start point.

- 2** Press the PREVIEW/REVIEW button at the moment the on-air cue is given.

The PREVIEW/REVIEW button lights up. When the tape passes the speed variation start point, DMC playback starts and continues at the speed(s) stored in memory.

When the tape passes the speed variation end point, normal-speed playback starts.

To start playback immediately after prerolling

Press the PREVIEW/REVIEW button.

The PREVIEW/REVIEW button lights up. When the tape passes the speed variation start point, DMC playback starts and continues at the speed(s) stored in memory. When the tape passes the speed variation end point, normal-speed playback resumes.

To stop the tape during DMC playback

Press the STOP button.

To exit DMC playback mode

Press the ALT/[F7] (DMC) buttons in the HOME menu to turn off the DMC indicator.

During DMC playback, the tape runs as shown in the diagram below.

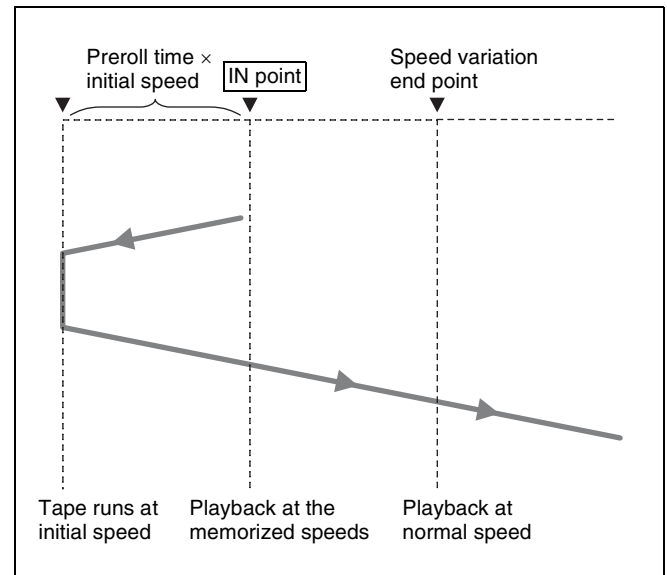

5-4-5 Playing Back Non-audio Data

Non-audio data recorded on a tape is detected automatically and played back.

Note

When non-audio data is being played back:

- Below the input display in the audio level meter section, the DATA mark lights in white.
- For the audio level meters, all regions light.
- The analog audio outputs (main line/monitor/headphones) are muted.
- The audio output level can be adjusted during non-audio data playback, but output non-audio data is not affected.

5-4-6 Performing Program Play

Overview

When using HDCAM-SR tapes, you can play them over the range $\pm 5.0\%$ of normal speed. This is called program play.

During program play you can correct the pitch of audio signals.

Note

The program play function is available only when all of the following conditions are met.

- Combination of SRW-5000/5500 and HKSR-5001 serial numbers:
 - SRW-5000/5500: Serial No. 12001 or higher
 - HKSR-5001: Serial No. 11001 or higher
- Tape format: HDCAM-SR
- System frequency: 4:2:2/1080/59.94i or 720/59.94P. No audio is output when playing tapes recorded at other system frequencies.
- Note about editing: Always use time code to check and set edit points when editing while performing program play on the player. Precise editing operations cannot be guaranteed if you use CTL signals.

To execute program play

Proceed as follows to execute program play.

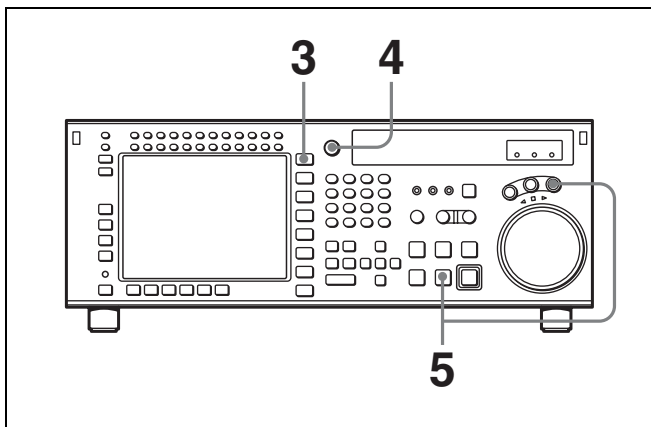

- 1 Set the same system setting for the VTR main unit and for FC output.

HD SDI signals will be output from both the HD SDI OUTPUT connectors and the FC OUT connectors.

- 2 Set VTR SETUP menu item 020 “P PLAY” to “on”.

- 3 Press the HOME button.

The HOME menu appears.

- 4 Turn the MULTI CONTROL knob to set the program play speed.

- 5 Press the PLAY button and VAR button at the same time.

Program play starts at the specified speed.

Note

During program play, HD SDI signals are output from the FC OUT connectors only. They are not output from the HD SDI OUTPUT connectors.

About audio pitch correction

Some menu settings are required to enable audio pitch correction during program play.

When audio pitch correction is enabled, it is also carried out at times other than during program play, whenever an HDCAM-SR tape is played that has a system setting (frame frequency) that is different from the current system setting. However, the difference between system settings must be within $\pm 5\%$, as shown below.

23.98 frames \leftrightarrow 24 frames

23.98/24 frames \leftrightarrow 25 frames

29.97 frames \leftrightarrow 30 frames

To enable pitch correction

Set VTR SETUP menu item 816 “PITCH CORRECTION” to “on”.

Pitch correction group settings

You can use VTR SETUP menu item 817 “PITCH CORRECTION GROUP select” to assign the 12 audio channels to groups.

You can assign up to 6 channels to 1 group. Pitch correction is performed at the same time for all channels in a group, so phase differences do not arise. However, phase differences may arise between different groups.

Pitch correction detection mode settings

You can use VTR SETUP menu item 818 “PITCH CORRECTION DETECT MODE select” to specify the detection mode for each pitch correction group.

Mode1: Search for zero-cross points in the audio data, and connect the zero-cross points.

Mode2: Search for zero-cross points in the same way as Mode1, but connect zero-cross points only when low-level samples are detected around the zero-cross points.

Mode3: At a regular interval corresponding to the playback speed, connect the audio data before and after the processing target with a cross fade.

OFF: Output audio data by performing rate conversion processing. This changes the frequency characteristics and pitch according to the specified program play speed.

Note

Cross fade processing may be performed if zero-cross points cannot be detected in Mode1 or Mode2 processing.

6-1 Basic Automatic Editing

6-1-1 Overview of Automatic Editing

Automatic edit modes

The VTR provides the following two modes for automatic editing:

Assemble mode

New scenes are added to the end of previously recorded scenes.
CTL signals, time codes, video and audio signals on tape in the player are recorded onto tape in the recorder VTR.

Insert mode

New scenes are inserted between previously recorded scenes.
CTL signals on tape in the recorder VTR are not overwritten. Video, digital audio, and time code signals can be recorded separately.
Both of these two edit modes support DMC editing. In insert mode, you can also use split editing.

Interpolation of time codes by the CTL counter

To use time codes as addresses of edit points, the time codes must be recorded on the tape in ascending order. As long as they are in ascending order, time codes do not have to be continuous. The CTL counter automatically interpolates data for editing even if there are breaks in the continuity in the time codes.

Steps in automatic editing

The sequence of steps that are taken to do automatic editing with two VTRs is as follows:

Select the edit mode (*see page 118*).



Set edit points for the recorder and player VTR (*see page 118*).



Preview the edit section (*see page 122*).



Perform the edit (*see page 125*).



Confirm and modify the edit points (*see pages 121 and 123*).



Confirm the results of the edit (*see page 126*).

Editing precautions

Using an editing control unit

When using an editing control unit to control the VTR, set the edit delay on the control unit so that CUT-IN and CUT-OUT commands are sent to the VTR five frames ahead of the actual edit point.

6-1-2 Setting Switches and Menus

Before editing, set the following switches and menus as shown below.

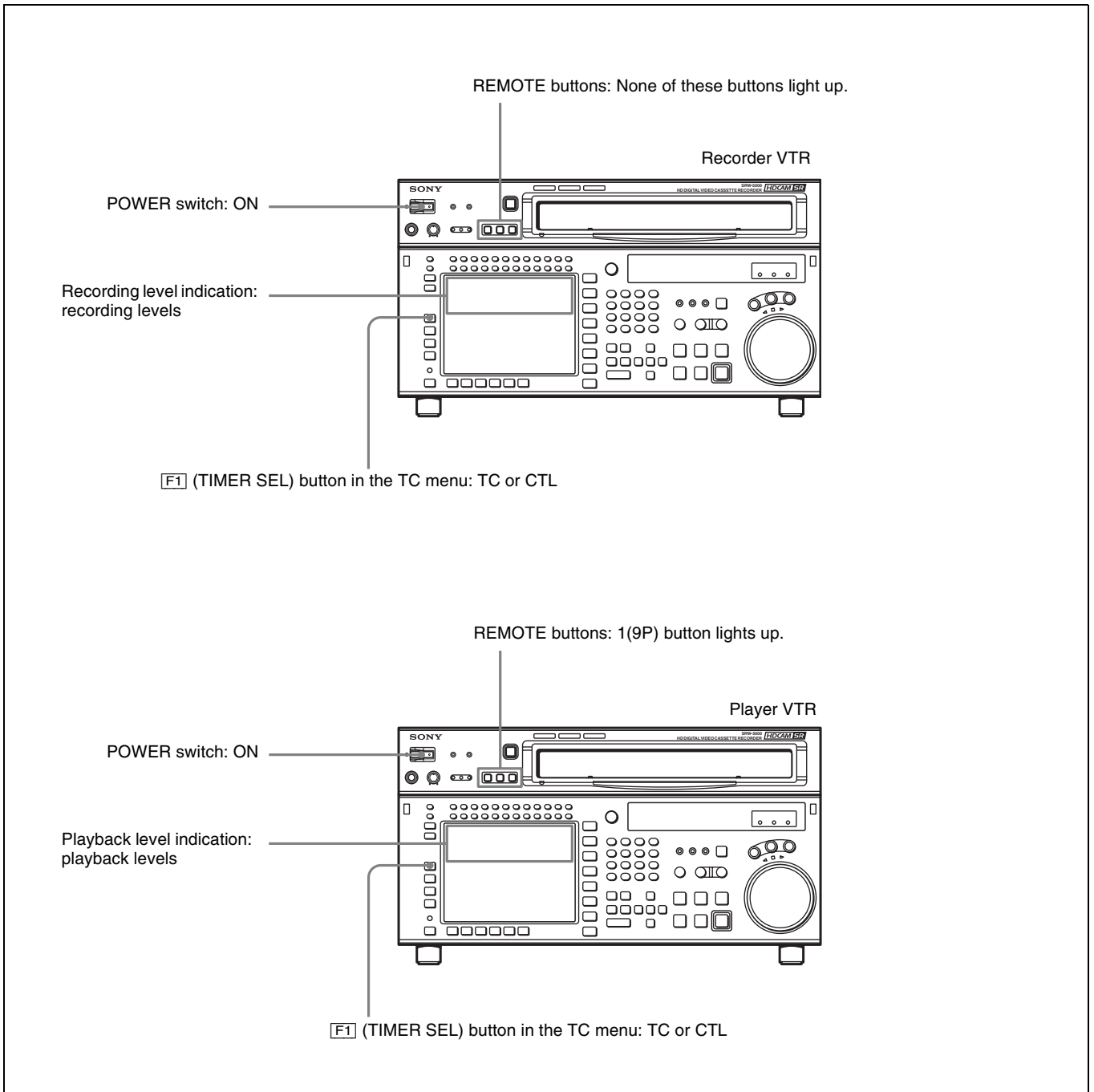

6-1-3 Selecting the Edit Mode

Select assemble or insert mode.

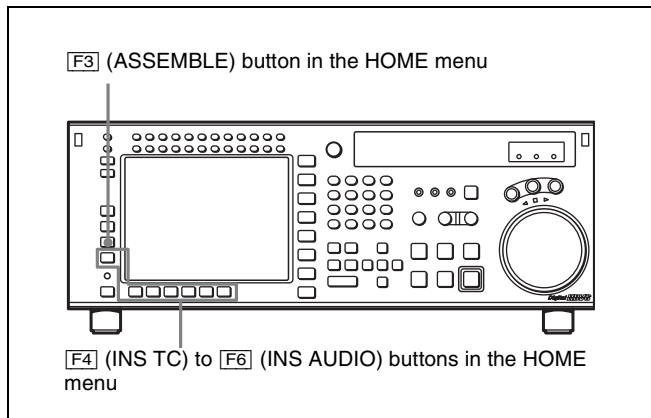

Press one of the following buttons to select the respective edit mode:

- **Assemble mode:** F3 (ASSEMBLE) button in the HOME menu
- **Insert mode:** the appropriate INSERT button in the HOME menu, F4 (INS TC), F5 (INS VIDEO), F6 (INS AUDIO)

6-1-4 Setting Edit Points

This section describes how to set edit points (IN and OUT points). In insert mode, a technique called split editing allows you to set edit points separately for video and audio.

Positioning and setting edit points

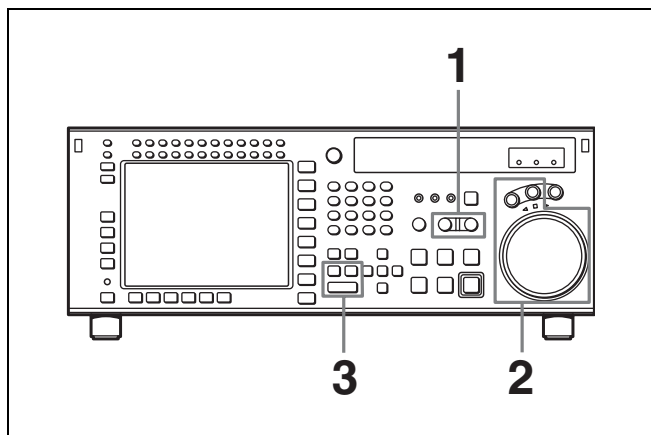

- 1 Press the RECORDER or PLAYER button to select the VTR for which edit points are to be set.

The button lights up.

- 2 Rotate the search dial in jog or shuttle mode to position the edit point.

For details on jog or shuttle playback, see “5-4-2 Variable Speed Playback” on page 110.

- 3 Press the IN (or OUT) button while holding down the ENTRY button.

The time data for the IN (or OUT) point appears in the menu display.

- 4 Repeat steps 1 to 3 to set the remaining edit points.

Setting edit points with the numeric buttons

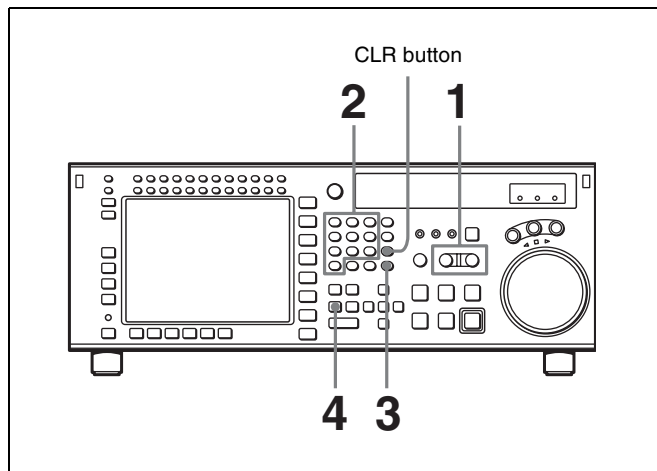

- 1 Press the RECORDER or PLAYER button to select the VTR for which edit points are to be set.

The button lights up.

- 2 Enter the edit point data with the numeric buttons.

For example, to enter 01H00M30S00F, press 1, 0, 0, 3, 0, 0, 0, 0. (You need not input leading zeros. If the entered value consists of less than eight digits, the leading digit(s) is (are) set to zero(s) when you press the SET button.)

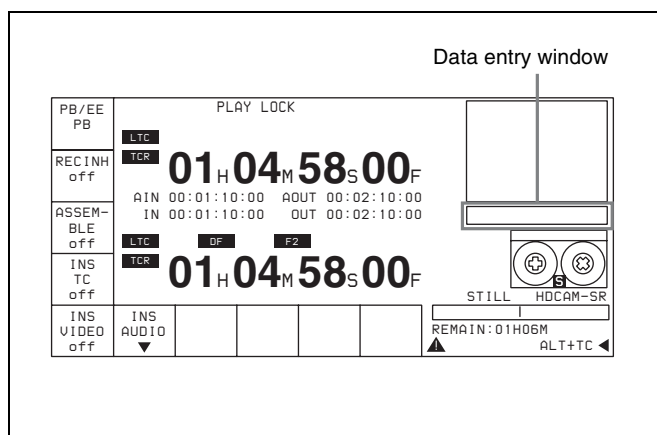

To delete entered data
Press the CLR button.

3 Press the SET button to set the input data.

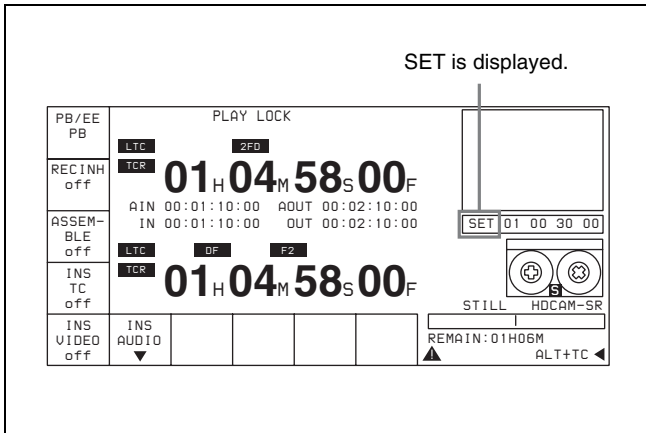

4 Press the IN (or OUT) button.

The time data for the IN (or OUT) point appears in the menu display.

About automatic edit point setting

Editing requires a total of four edit points: IN and OUT points for both the recorder and player VTRs. However, as soon as you set three edit points, the VTR automatically sets the fourth point.

In the figure below, the points enclosed in a box have been set manually, while the OUT point for the player VTR has been set automatically.

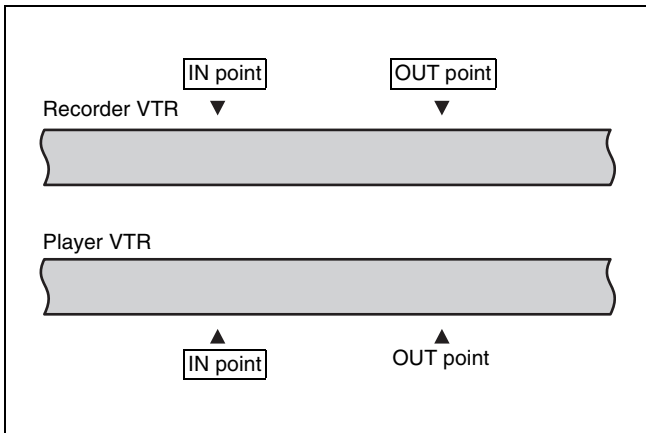

Whether set manually or automatically, all edit points can be changed or deleted at any time.

Automatic setting of OUT points

When the fourth edit point (OUT point) is set, the edit point data is activated and the invalid point is automatically deleted.

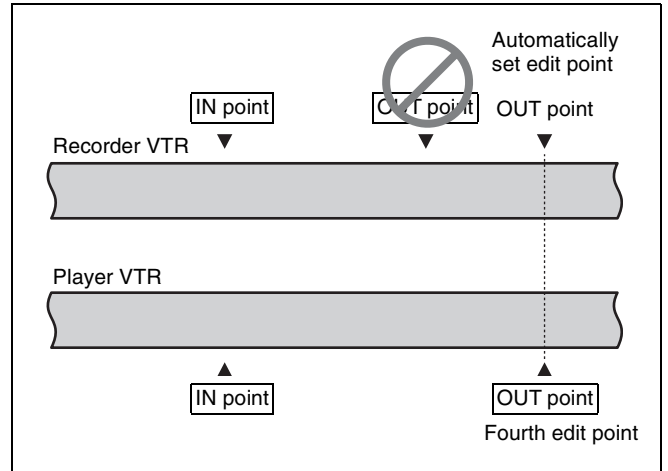

Automatic setting of IN points

When an IN point is corrected, the OUT point is set automatically using the duration of the VTR whose edit points were not changed.

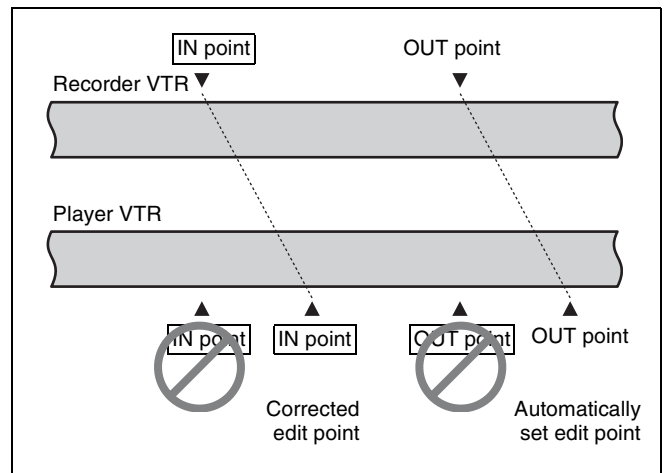

Split editing

Positioning and setting edit points

Split editing allows you to set edit points separately for video and audio. Set audio edit points with the AUDIO IN/OUT buttons and video edit points with the IN/OUT buttons.

Split editing, however, can only be done when the recorder VTR is in insert mode.

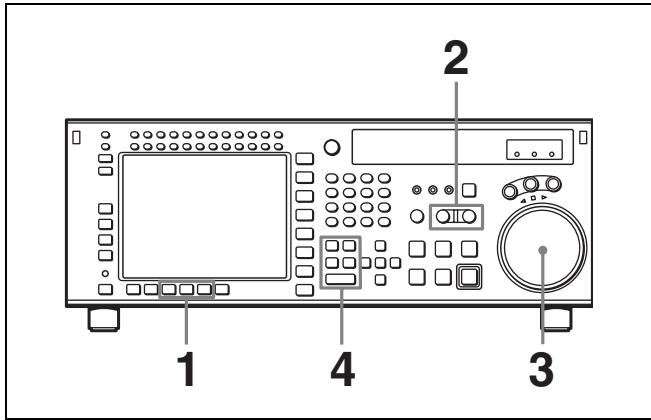

- 1 Press the appropriate INSERT button (**[F4]** (INS TC), **[F5]** (INS VIDEO), **[F6]** (INS AUDIO)).
- 2 Press the RECORDER or PLAYER button to select the VTR for which edit points are to be set.
The button lights up.
- 3 To locate the edit points, rotate the search dial in jog or shuttle mode.
For details on jog/shuttle playback modes, see “5-4-2 Variable Speed Playback” on page 110.
- 4 Press one of the IN, OUT, AUDIO IN or AUDIO OUT button while holding down the ENTRY button.

- 5 Repeat steps 2 to 4 to set the remaining edit points.

Setting an edit point with the numeric buttons

- 1 Press the desired INSERT button (**[F4]** (INS TC), **[F5]** (INS VIDEO), **[F6]** (INS AUDIO)).
- 2 Press the RECORDER button or PLAYER button, to select the VTR on which you will set the edit point.
The button you pressed lights.
- 3 With the numeric buttons, enter data into the data entry window.

For example, to enter 01H00M30S00F, press 1, 0, 0, 3, 0, 0, 0. (You need not input leading zeros. If the entered value consists of less than eight digits, the leading digit(s) is (are) set to zero(s) when you press the SET button.)

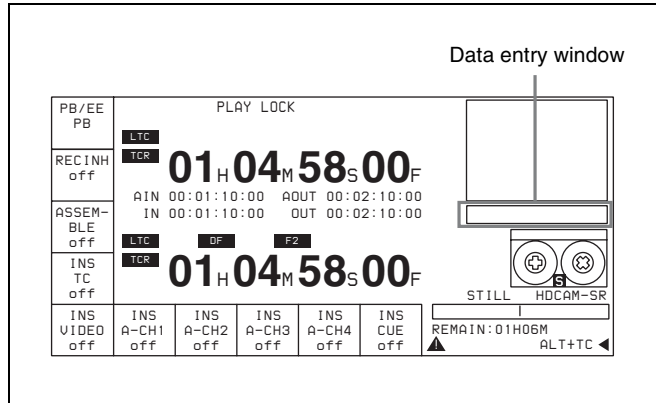

To delete entered data

Press the CLR button.

- 4 Press the SET button to confirm the input data.

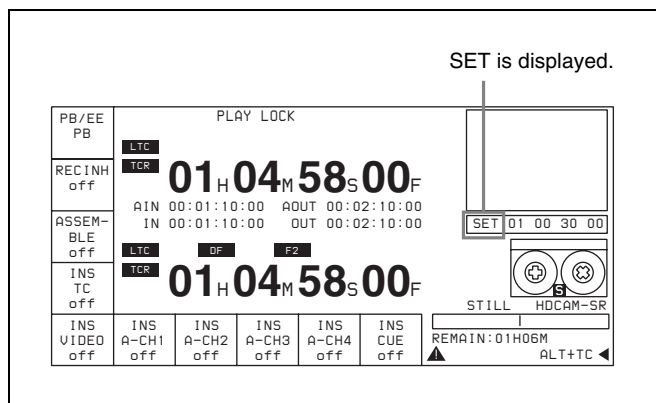

- 5 Press any of the IN, OUT, AUDIO IN, and AUDIO OUT buttons.

When the edit point is set, it appears on the editing data display.

About automatic split edit point setting

Split editing requires a total of eight edit points: four edit points for video editing (IN and OUT points for both the recorder and player VTRs) and four edit points for audio editing (AUDIO IN and OUT points for both the recorder and player VTRs). However, as soon as you set five edit points, the VTR automatically sets the remaining three points. For example, if you set three edit points for video (or audio) and two for audio (or video), the remaining three points are automatically set, regardless of whether these points are for the recorder or player.

In the following example, the points enclosed in a box have been set manually and the AUDIO OUT point for the recorder VTR, and the AUDIO IN and OUT points for the player VTR have been set automatically.

Note that whether set manually or automatically, all edit points can be changed or deleted at any time.

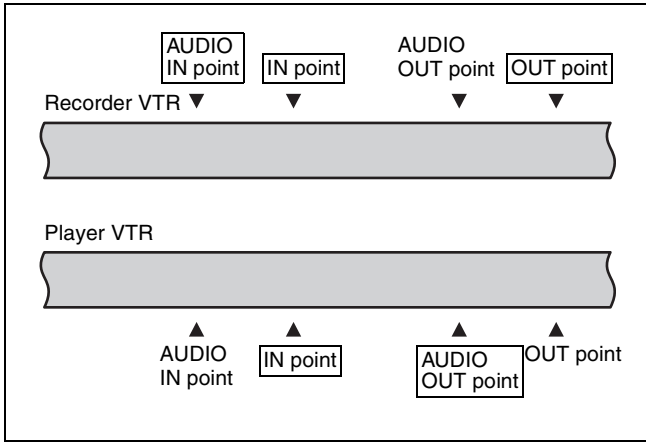

Automatic setting of AUDIO OUT points

When the sixth edit point (AUDIO OUT point) is set, the edit point data is activated and the invalid AUDIO OUT points are automatically deleted.

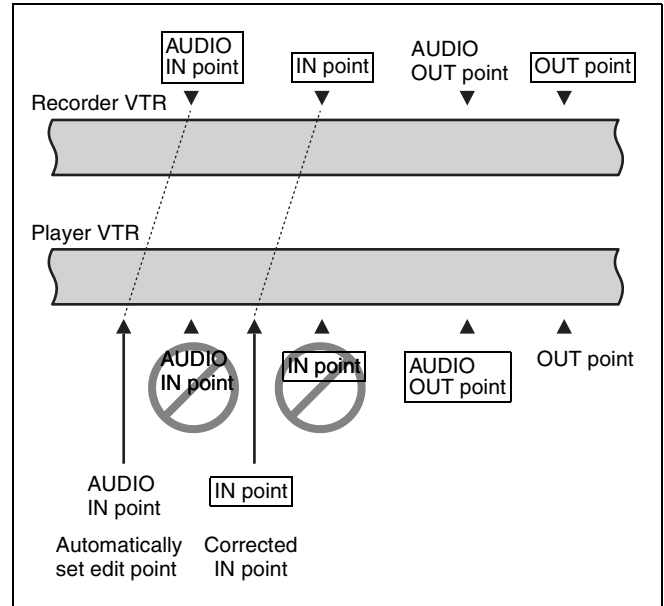

You can use the VTR SETUP menu to select an audio edit mode from among cut, cross-fade, and fade-in/out, and set the duration of the selected edit.

For details, see the menu items in the 300 range in the VTR SETUP menu.

Using a VTR without the split editing function

If the player VTR does not support the separate setting of edit points for video and audio, you can set AUDIO IN and AUDIO OUT points on the recorder and three video edit points to enable split editing.

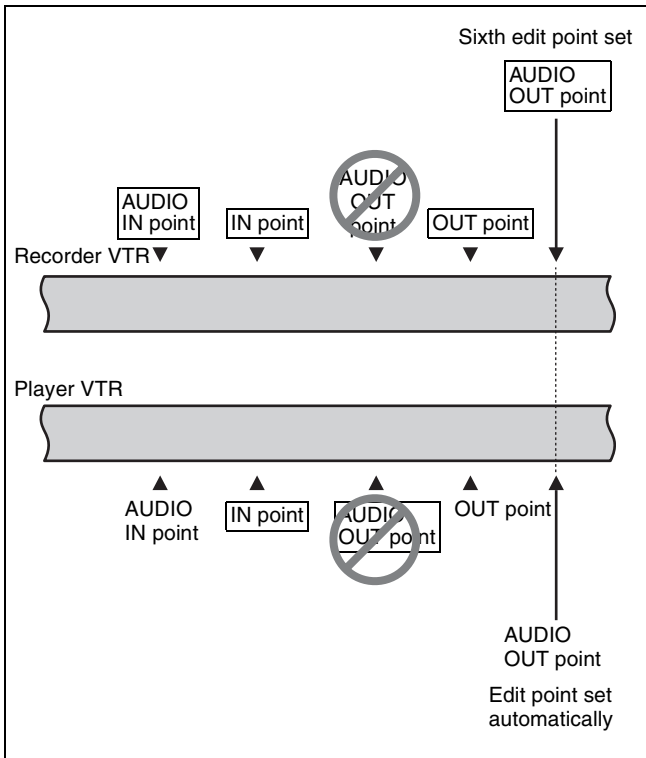

Automatic setting of edit points by correcting IN points

When IN points are corrected, the duration in the uncorrected VTR is used to automatically set OUT points and AUDIO IN/OUT points.

6-1-5 Editing Non-audio Data

Before editing non-audio data, set the VTR SETUP menu item 317 “AUDIO EDIT MODE” to “cut edit”.

Note

Noise may be produced during editing of certain non-audio data.

6-1-6 Confirming Edit Points

Displaying the duration between two edit points

The following six kinds of duration can be displayed in the time data display window:

- Between IN and OUT points
- Between IN and AUDIO OUT points
- Between IN and AUDIO IN points
- Between OUT and AUDIO OUT points
- Between OUT and AUDIO IN points

- Between AUDIO IN and AUDIO OUT points

Durations are calculated as follows.

- If both IN and OUT points are set, the duration is the time between the points.
- If one of the edit points is not set, the duration is set to 00:00:00.

1 Press the RECORDER or PLAYER button to select the VTR for which you want to confirm a duration.

The button lights up.

2 Hold down any two IN, OUT, AUDIO IN, or AUDIO OUT buttons.

The duration between the points corresponding to the two buttons is displayed. The value can be negative.

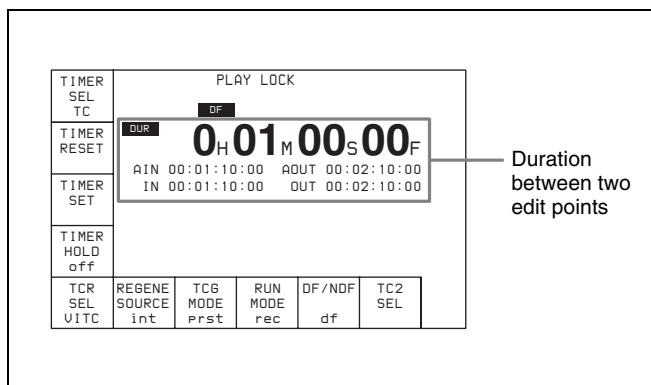

6-1-7 Cuing Up and Prerolling

You can preroll the tape to a point prior to the edit start point, or cue up the tape to any edit point. Follow the procedure below to cue up or preroll the tape.

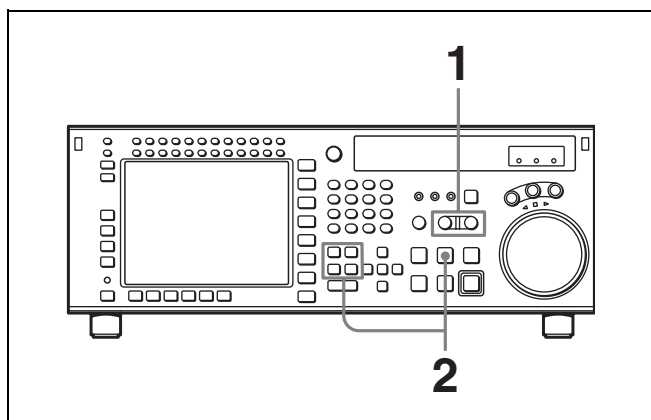

1 Press the RECORDER or PLAYER button to select the VTR which you want to operate.

The button lights up.

2 To cue up the tape to an edit point

Press one of the IN, OUT, AUDIO IN, or AUDIO OUT button while holding down the PREROLL button.

The tape moves to the edit point corresponding to the button, then stops.

To preroll the tape

Press the PREROLL button.

The tape is rewound to a point before the edit start point by the amount determined by the preroll time setting.

Note

When the [F1] (TIMER SEL) button in the TC menu is set to CTL mode, cuing up is slightly slower than in TC mode. This is to maintain the accuracy of the CTL signals. You can set up the VTR so that priority is placed on cuing accuracy or speed. Change the setting of the VTR SETUP menu item 403 "CUEUP BY TC" and menu item 404 "CUEUP BY CTL".

Changing the preroll time

The preroll time is factory set to 5 seconds, but can be set to any time between 0 and 30 seconds, in 1-second steps.

For details, see "4-2-6 Setting the Preroll Time (PREROLL TIME)" on page 53.

When changing the preroll time, set it so that the recorded section prior to the edit start point is longer than the preroll time.

The preroll time used in automatic editing is the preroll time set for the recorder.

6-1-8 Previewing

Follow the procedure below to preview the edit.

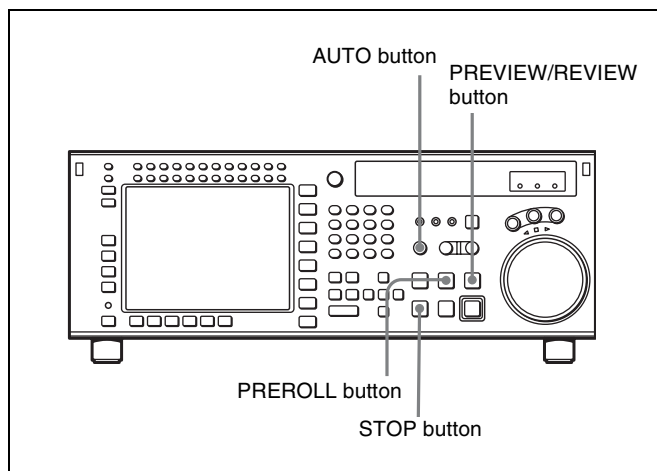

To preview the edit, press the AUTO button to switch to AUTO mode, then press the PREVIEW/REVIEW button.

During previewing, the PREVIEW/REVIEW button lights up.

After previewing, correct the edit points as required, then do the preview again.

For details on modifying edit points, see “6-1-9 Modifying Edit Points” on page 123.

To stop previewing

Press the STOP button.

The tape stops immediately.

To rewind the tape to the preroll point

Press the PREROLL button.

To rewind the tape to the edit point

Press the PREROLL button together with the button corresponding to the edit point.

Monitoring signals during previewing

During previewing, you can monitor the following video and audio signals on a monitor connected to the recorder VTR:

- Between preroll and IN points: Playback signal of the recorder VTR can be monitored.
- Between IN and OUT points: Playback signal of the player VTR can be monitored in E-E mode.
- Between OUT and post-roll points: Playback signal of the recorder VTR can be monitored.

This may be illustrated as shown below:

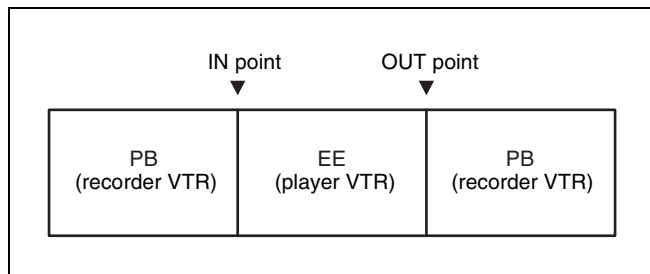

6-1-9 Modifying Edit Points

If an edit point is incorrectly set, for example, if an OUT point is located before an IN point, or the length of an edit section is different for the recorder and player VTRs, the time data for the incorrectly set edit point flash indicating that the VTR cannot perform editing or previewing. In this case, delete the edit point, then set a new one correctly. You can also move an edit point position in one-frame units.

Deleting edit points

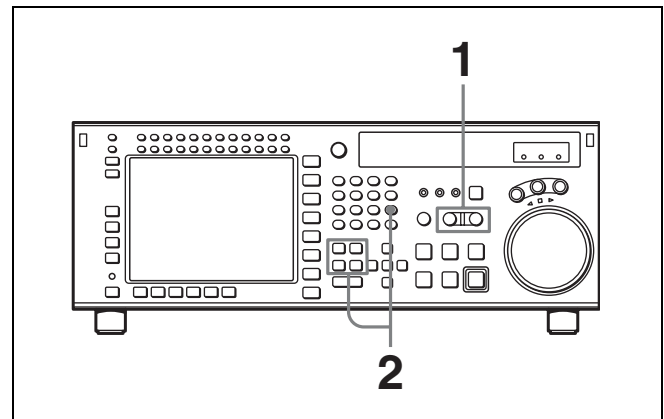

- 1 Press the RECORDER or PLAYER button to select the VTR on which to perform the edit point deletion.

The button lights up.

- 2 Press one of the IN, OUT, AUDIO IN or AUDIO OUT button while holding down the CLR button to delete the corresponding edit point.

The edit point is deleted and ---:--:--:-- appears in the time data display.

Moving an edit point position by one frame at a time

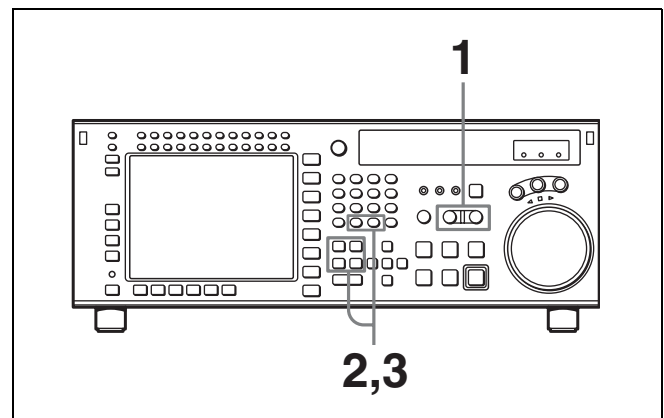

- 1 Press the RECORDER or PLAYER button to select the VTR on which to modify the edit point.

The button lights up.

- 2 Press the + or – button while holding down one of the IN, OUT, AUDIO IN or AUDIO OUT button.

Pressing the + or – button moves the edit point by one frame forward or backward, respectively.

- 3 After making the modification, release the respective edit point button that you have been holding down at step 2.

Moving an edit point position with the numeric buttons

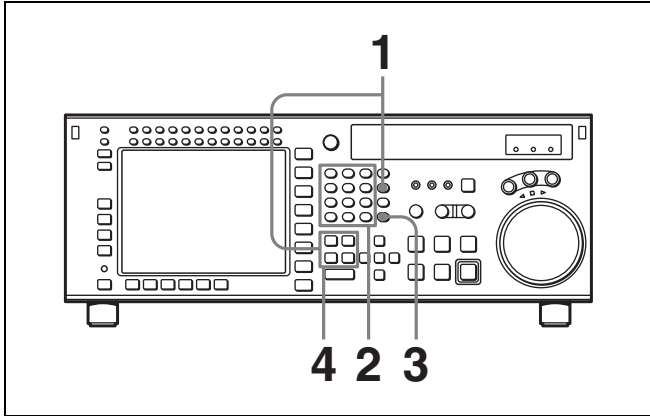

- 1 Press one of the IN, OUT, AUDIO IN, or AUDIO OUT button while holding down the RCL button.

Time data for the edit point appears in the data entry window.

- 2 Press the + or – button, then use the numeric buttons to enter the value to be added or subtracted.

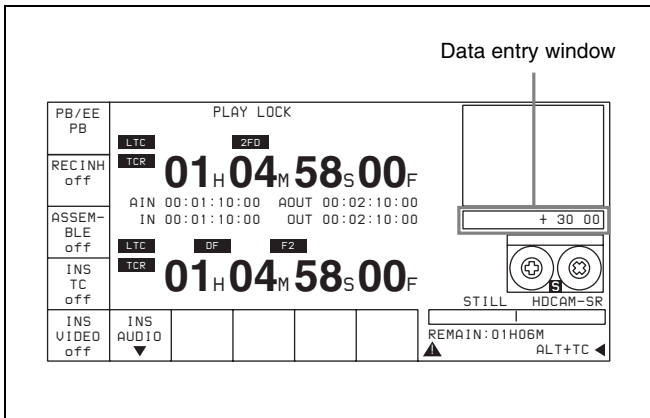

To cancel the entered value
Press the CLR button.

- 3 Press the SET button.

The result of the addition or subtraction is entered.

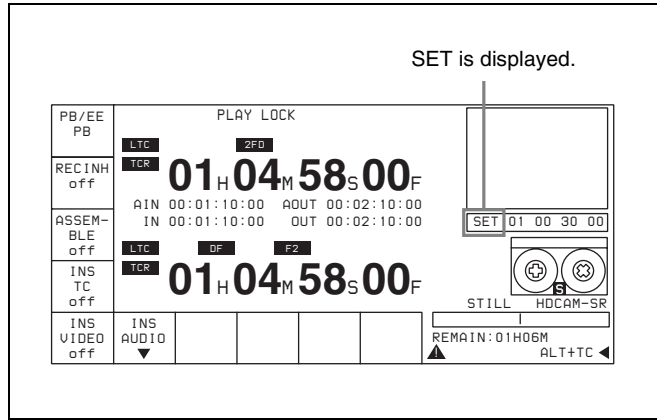

- 4 Press one of the IN, OUT, AUDIO IN, or AUDIO OUT button.

The modified time data for the edit point appears in the time data display.

6-1-10 Performing Automatic Editing

Overview

Once you have set the necessary edit points, the AUTO button lights up to show that the VTR is ready for automatic editing.

During automatic editing, the tape in the recorder VTR and the player VTR move as shown in the diagram below.

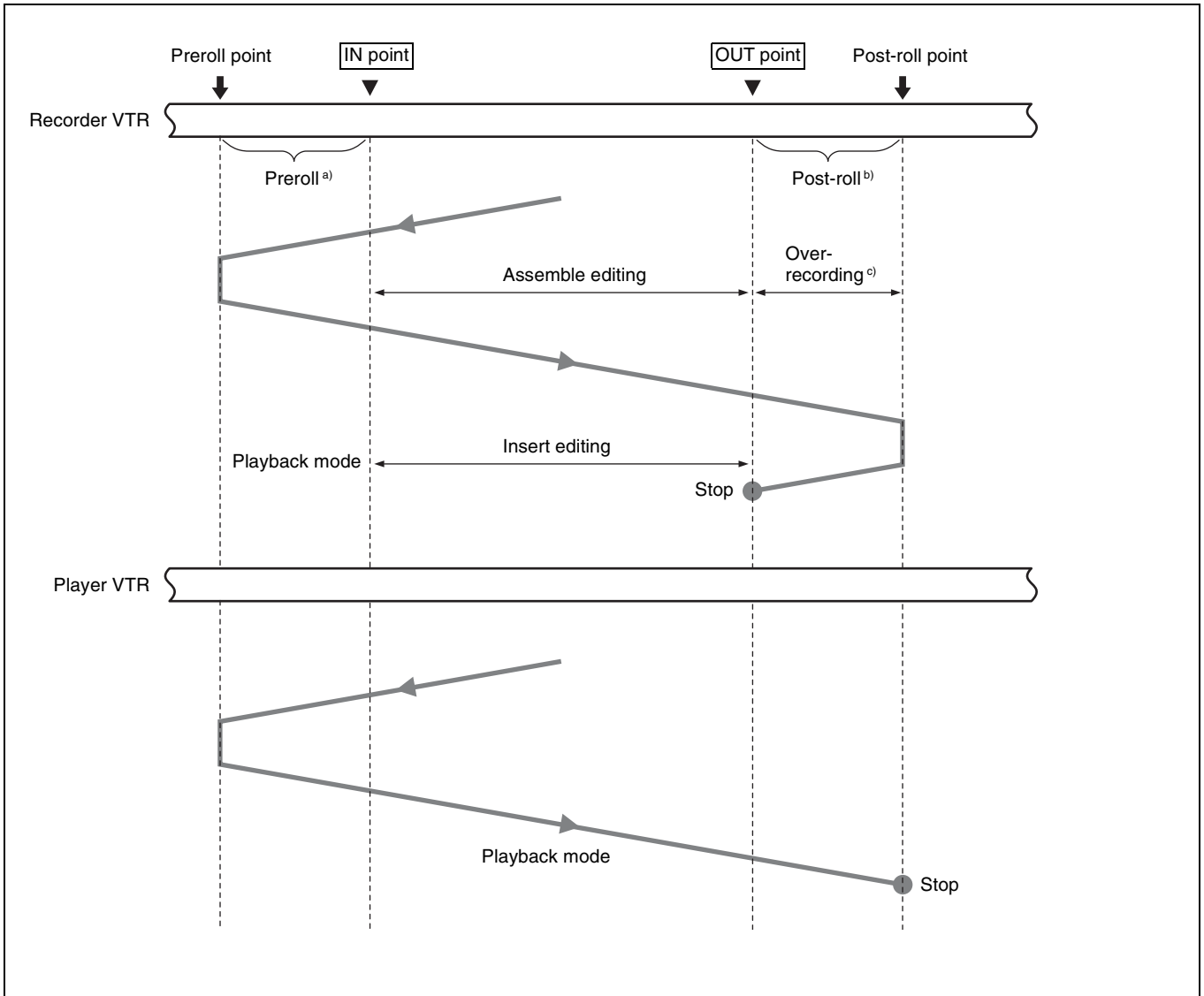

a) Preroll time: Factory-set to 5 seconds. Can be set from 0 to 30 seconds, in units of seconds, through the VTR SETUP menu.

b) The post-roll time can be set between 0 and 30 seconds in units of seconds using the VTR SETUP menu.

c) Over-recording time: 2 seconds.

Monitoring signals during editing

During editing, you can monitor signals between preroll and postroll points, including portions between IN and OUT points, through the CONF1 (confidence) heads. This allows you to monitor the video and audio signals that are just being edited.

The video and audio signals that can be monitored are shown in the diagram below.

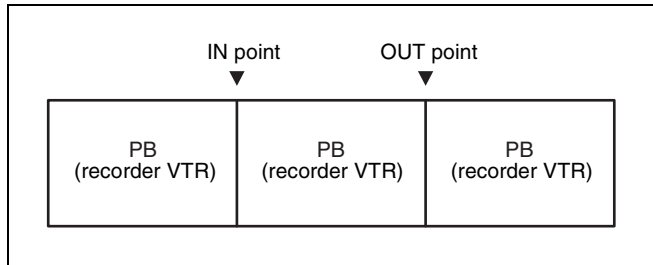

To perform automatic editing

To carry out automatic editing, press the AUTO button, turning it on, then press the REC/EDIT button. During editing the REC/EDIT button lights up, and goes off at the end.

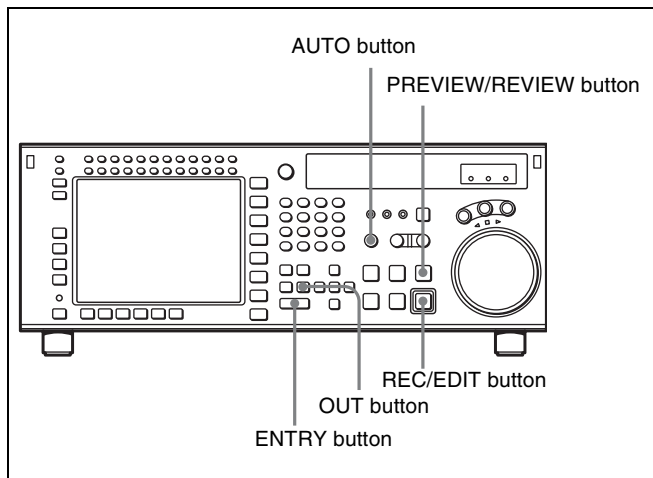

To stop automatic editing

Press the OUT button while holding down the ENTRY button. The point where the OUT button is pressed is treated as an OUT point and editing stops.

To confirm the results of the editing

Press the PREVIEW/REVIEW button to confirm the edit results. When the view ends, the tape rewinds to the OUT point, then stops.

Modifying edit points for automatic editing later

After you perform automatic editing, the time data of IN, OUT, AUDIO IN or AUDIO OUT points remain stored in

memory. The stored data can be used later to modify edit points or to execute automatic editing again. Follow the procedure below to modify edit points after executing automatic editing.

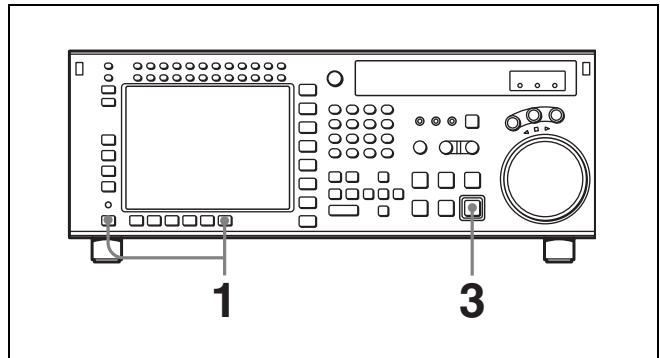

1 In the HOME menu, press the ALT/[F10] (LAST EDIT) buttons.

The edit points used in the last automatic edit are restored.

2 Modify the edit points.

For details on modifying edit points, see “6-1-9 Modifying Edit Points” on page 123.

3 Press the REC/EDIT button.

The VTR performs automatic editing.

6-2 Advanced Automatic Editing

This section describes the following advanced editing methods:

- DMC editing
- Animation editing
- Preread editing

6-2-1 DMC Editing

If your player VTR has DT[®] (Dynamic Tracking) capability, you can perform variable speed editing by controlling the playback speed from the lower control panel. This type of editing is called DMC editing.

Overview of DMC editing

Requirements for DMC editing

- DMC editing may be done during assemble or insert editing, but not during split editing.
- The player VTR must support DT playback.

Tape movement during DMC editing

During DMC editing, the tape moves as shown in the diagram below.

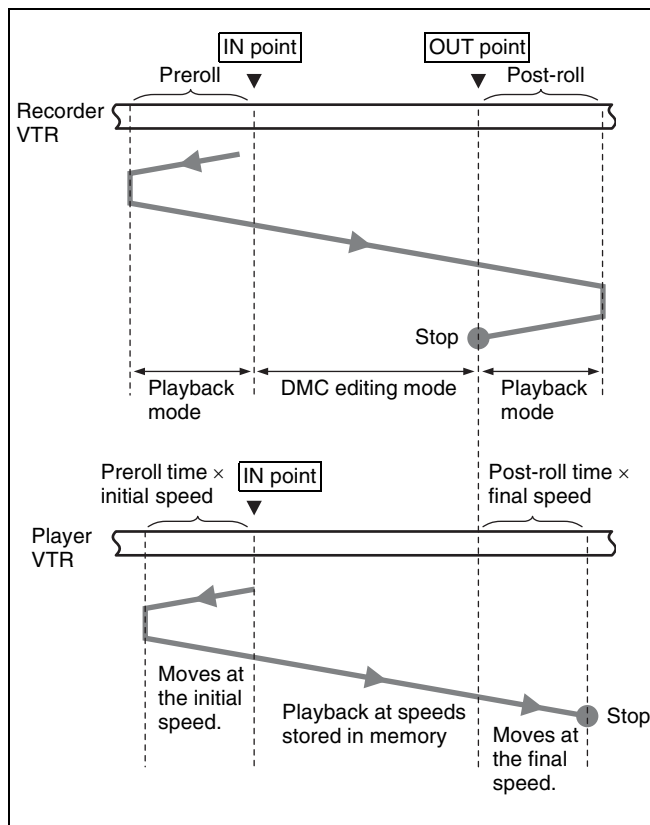

Setting edit points and playback speed

Use the procedure below to set edit points and playback speeds for DMC editing.

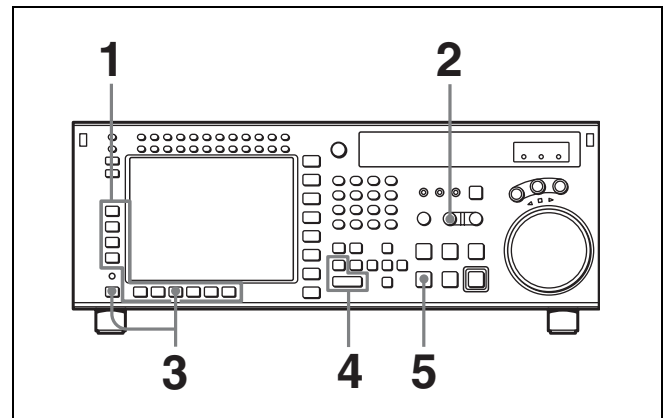

1 Press the **[F3]** (ASSEMBLE) button in the HOME menu, or press the respective INSERT button (**[F4]** (INS TC), **[F5]** (INS VIDEO), or **[F6]** (INS AUDIO) button) to select the edit mode that you want.

2 Press the **PLAYER** button to set the connected VTR to act as the player VTR.

The **PLAYER** button lights up.

3 Press the **ALT/[F7]** (DMC) buttons in the HOME menu.

The system enters DMC editing mode.

4 Press the **IN** button while holding down the **ENTRY** button to set an edit point.

Note

You cannot set an **OUT** point for the player VTR for DMC editing.

5 Press the **STOP** button to enter STOP mode.

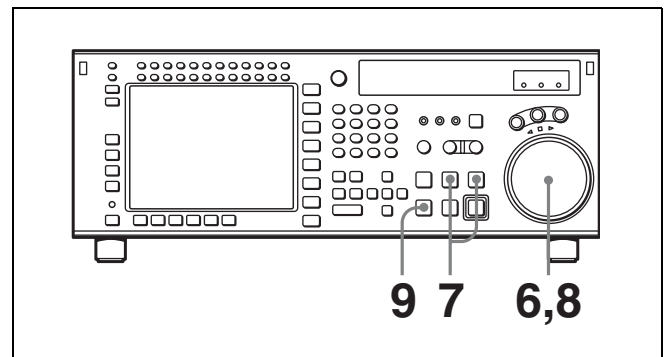

6 Turn the search dial to set the initial speed.

The selected speed is displayed in the time data display.

- Press the PREVIEW/REVIEW and PREROLL buttons at the same time.

The tape prerolls and the player VTR begins playing at the initial speed.

- When the ■ indicator appears with a beep indicating that the IN point has been passed, rotate the search dial to the desired playback speed(s).

The varying playback speeds are stored in memory while the ■ indicator appears in the display.

- Press the STOP button.

If the ■ indicator goes off before you press the STOP button

The VTR has reached its storage capacity, and cannot store any more playback speed variations.

To exit DMC editing mode

Press the ALT/[F7] (DMC) buttons in HOME menu.

Performing DMC editing

After setting the playback speeds in preview mode, press the RECORDER button and REC/EDIT button. DMC editing is performed at the playback speed(s) stored in memory.

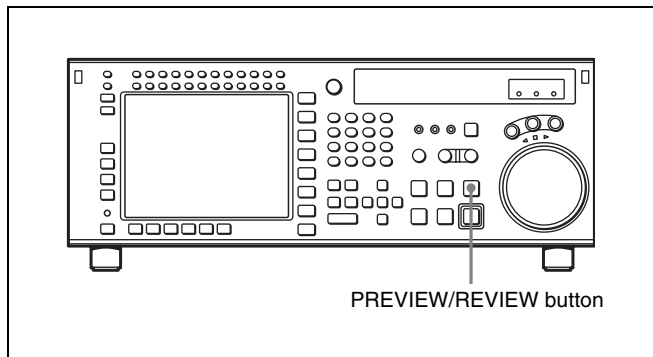

To confirm the results of DMC editing

Press the PREVIEW/REVIEW button.

6-2-2 Animation Editing

Animation editing is a form of insert editing which makes it easier to record a succession of still frames in fixed field or frame units. The procedure for editing after selecting animation editing is exactly the same as for normal insert editing.

To select animation editing, use the VTR SETUP menu item 301 "EDIT OPERATION MODE".

normal: Selects normal insert editing.

CG: Selects editing in frame units, principally for recording computer graphics (CG).

When the edit completes, the OUT point

automatically becomes the next IN point, and the next OUT point is set automatically with 1 frame added.

Follow the procedure below to perform animation editing.

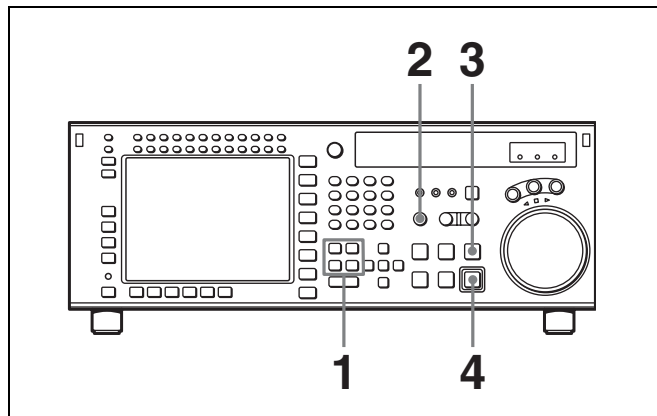

- Set the IN point.

The OUT point is set automatically.

- Press the AUTO button.

The button lights up.

- Press the PREVIEW/REVIEW button to preview.

- Press the REC/EDIT button.

Automatic editing starts.

When the edit completes, the OUT point automatically becomes the next IN point, and the next OUT point is set automatically.

Repeat steps 3 to 4 to perform animation editing.

6-2-3 Preread Editing

Video and digital audio signals already recorded on the tape can be used as an edit source for insert editing. This type of editing is called preread editing, as the VTR uses preread heads to read signals in advance. Signals that are read in advance can be sent to mixers for mixing, then recorded to the original channels or other digital audio channels.

The preread editing settings are performed with the ALT/[F1] (PRE READ) buttons in the HOME menu.

For details on the settings, see "4-2-4 Preread Settings (PRE READ)" on page 53.

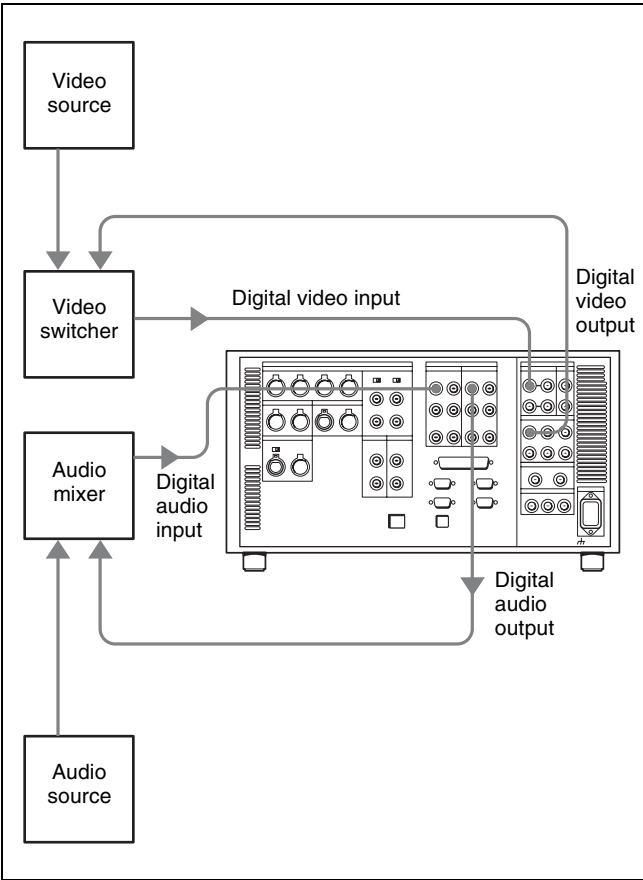

- 5 Press the ALT/[F1] (PRE READ) buttons to select “off”.
- 6 Check that no loop connections remain.

Notes

- In pre-read editing, if an input video signal is used as the reference signal for the output video signal, oscillation may occur because of loop connections. To avoid this, select the external reference signal for pre-read editing by setting the VTR SETUP menu item 005 “SERVO/AV REFERENCE select” to “external”.
- When pre-read mode is selected, no E-E signals are output in any operation modes to prevent oscillation caused by loop connections. If pre-read mode is deselected while a loop between the input and output of the same channel exists, E-E signals are output and oscillation occurs. To prevent oscillation, do the procedure below to select PB mode for both the video and digital audio channels before the start of pre-read editing.

- 1 Press the ALT/[F1] (PRE READ) buttons in the HOME menu and select “on”.
- 2 Make the required connections for pre-read editing.
- 3 Perform pre-read editing after selecting the insert editing mode.
- 4 After pre-read editing, undo all the connections used for the pre-read editing.

6-3 Manual Editing

Follow the procedure below to perform manual editing.

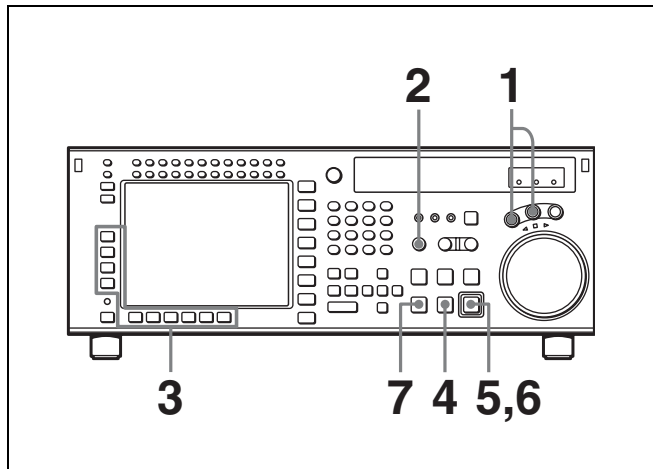

- 1** Enter jog or shuttle mode to position the tape at a place at least three seconds before the position at which you want to set an edit point.
- 2** Press the AUTO button to turn it off.
- 3** Press the **[F3]** (ASSEMBLE) button in the HOME menu or press the respective INSERT button (**[F4]** (INS TC), **[F5]** (INS VIDEO) or **[F6]** (INS AUDIO) button) to select the edit mode that you want.
- 4** Press the PLAY button.
Playback starts.
- 5** Press the REC/EDIT button at the point where you want to start editing (IN point).
The REC/EDIT button lights, and editing starts.
- 6** Press the REC/EDIT button at the point where you want to end editing (OUT point).
Editing ends, but the tape continues to run in playback mode.
- 7** Press the STOP button to stop the tape.

Note

To ensure a stable picture, start playback at least three seconds before the IN point.

Appendix

Maintenance

Head Cleaning

Use the BCT-HD12CL Cleaning Cassette to clean the video and audio heads. Read the instructions included with the cleaning cassette carefully, as improper usage can damage the heads.

If you insert the cleaning cassette, it is automatically ejected after a head cleaning operation which lasts for 10 seconds.

Note

Do not run the cleaning tape more than 6 times in succession to avoid damaging the heads.

Please refer to the Maintenance Manual Volume 1 on cleaning the video and audio heads.

Moisture Condensation

If you suddenly move the VTR from a cold location to a warm one, or use the VTR in a very humid place, moisture in the air can form on the head-drum or tape guide. This is called moisture condensation.

If you play a tape under these conditions, the tape may adhere to the drum where moisture has collected and become damaged.

If moisture condenses on the head-drum while you are operating the VTR, the error message "ERROR-10" appears in the time data display section.

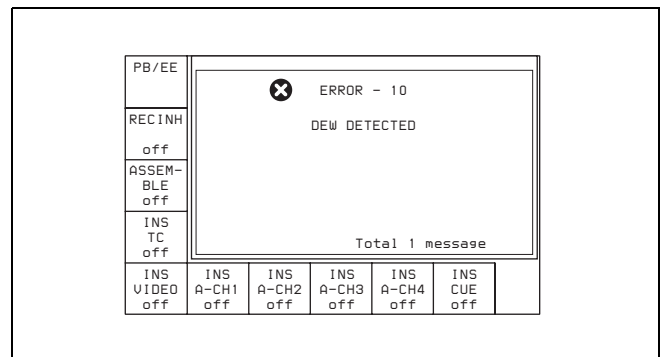

When this error message appears, the VTR enters the protection mode and certain operations become inoperable.

Once the moisture has evaporated, the error message disappears and the VTR becomes normal.

Please refer to the Maintenance Manual Volume 1 on protection mode.

If "ERROR-10" appears immediately after turning the VTR on

Leave the VTR turned on and wait until the error message goes off. Inserting a cassette is not possible while the message is on.

When the error message disappears, you can use the VTR.

If you move the VTR from a cold to a warm location

Leave the VTR turned off for about ten minutes since some time is needed for the condensation-detection mechanism to work.

Specifications

General

Record format	HDCAM-SR (SRW-5000/5500) or HDCAM (SRW-5500)
Power requirements	100 to 240 V AC, 50/60 Hz
Power consumption	320 W (with all option boards installed)
Peak inrush current	(1) Power ON, current probe method: 54 A (240 V), 17 A (100 V) (2) Hot switching inrush current, measured in accordance with European standard EN55103-1: 33 A (230 V)
Operating temperature	+5°C to +40°C (+41°F to + 104°F)
Storage temperature	-20°C to +60°C (-4°F to + 140°F)
Humidity	25% to 80% (relative humidity)
Mass	30 kg (66 lb 26 oz)
Dimensions	427 × 218 × 544 mm (w/h/d) (16 ⁷ / ₈ × 8 ⁵ / ₈ × 21 ¹ / ₂ inches)

Tape system

Tape speed	HDCAM-SR: 94.1 mm/s (with the frame frequency of 24 Hz)/98.1 mm/s (with the frame frequency of 25 Hz)/117.6 mm/s (with the frame frequency of 29.97 Hz) HDCAM: 96.7 mm/s (with the frame frequency of 29.97 Hz)/80.6 mm/s (with the frame frequency of 25 Hz)/ 77.4 mm/s (with the frame frequency of 24 Hz) Digital Betacam: 96.7 mm/s
HDCAM-SR recording and playback time (using BCT- 124SRL)	155 minutes (with the frame frequency of 24 Hz)/149 minutes (with the frame frequency of 25 Hz)/124 minutes (with the frame frequency of 29.97 Hz)
HDCAM playback time (SRW-5000; using BCT- 124HDL) / HDCAM recording and playback time (SRW-5500; using BCT-124HDL)	155 minutes (with the frame frequency of 24 Hz)/149 minutes (with the frame frequency of 25 Hz)/124 minutes (with the frame frequency of 29.97 Hz)
Digital Betacam playback time (using BCT-D124L)	124 minutes
Fast forward/rewind time	Approx. 4 minutes (using BCT-124SRL)

Search speed
Shuttle mode

HDCAM-SR playback: Still to approx.
±50 times normal playback speed
(with the frame frequency of 24 Hz)
Still to approx. ±48 times normal
playback speed (with the frame
frequency of 25 Hz)
Still to approx. ±40 times normal
playback speed (with the frame
frequency of 30 Hz)
HDCAM playback: Still to approx. ±50
time normal playback speed (with the
frame frequency of 29.97 Hz)/ Still to
approx. ±58 time normal playback
speed (with the frame frequency of 25
Hz)
Digital Betacam playback: Still to
approx. ±50 times normal playback
speed

Variable mode

HDCAM-SR playback: -1 to +2 times
normal playback speed
HDCAM playback: -1 to +2 time normal
playback speed
Digital Betacam playback: Still to
approx. -1 to +3 time normal playback
speed

Jog mode

HDCAM-SR playback: Still to ±2 times
normal playback speed
HDCAM playback: Still to ±3 times
normal playback speed
Digital Betacam playback: Still to ±3
times normal playback speed

Dynamic Tracking range

HDCAM SR playback: -1 to +2 times
normal playback speed
HDCAM playback: -1 to +2 times
normal playback speed
Digital Betacam playback: -1 to +3 times
normal playback speed

Load/unload time

7 seconds or less

Recommended tapes

HDCAM-SR cassette (S, L):
BCT-6SR/33SR/40SR
BCT-64SRL/94SRL/124SRL
HDCAM cassette (S, L):
BCT-6HD/12HD/22HD/40HD
BCT-34HDL/64HDL//94HDL/
124HDL
Digital Betacam cassettes (S, L)
(for playback only)

Digital video system

Digital video signal format

Sampling frequency	Y: 74.25 MHz P _B /P _R : 37.125 MHz RGB: 74.25 MHz
Quantization	10 bits/sample
Compression	MPEG-4 Studio Profile
Channel coding	S-NRZ
Error correction	Reed-Solomon code

Analog composite output

Bandwidth	Y: 0 to 5.75 MHz +0.5 dB/-3.0 dB
S/N ratio	56 dB or more
Y/C delay	15 ns or less
K factor (2T Pulse)	1% or less
Output SCH phase	Conforming to RS-170A/CCIR R.624-3

Digital audio system

Digital audio signal format (HDCAM-SR: CH-1 to CH-12, HDCAM: CH1 to CH4)

Sampling frequency	48 kHz (synchronized with video)
Quantization	24 bits/sample
Wow and flutter	Below measurable level
Headroom	Selectable settings: 20, 18, 16, 15, and 12 dB
De-emphasis	T1=50 μs, T2=15 μs (automatically selected in playback mode)

Analog output

D/A quantization	24 bits/sample
Frequency response	20 Hz to 20 kHz +0.5 dB/-1.0 dB (0 dB at 1 kHz)
Dynamic range	96 dB or more (at 1 kHz)
Distortion	0.05% or less (at 1 kHz, emphasis on, reference level)
Crosstalk	-80 dB or less (at 1 kHz, between any two channels)

Input connectors

HD SDI INPUT	
A/INPUT MONITOR	BNC (2) HD SDI (1.485 Gbps) (conforming to SMPTE 292M/BTA S004B)
B (OPTION)/INPUT MONITOR	BNC (2) (when the optional HKSR-5003 is installed)

REF. INPUT1, REF. INPUT2 (OPTION)	BNC (2 + 2 loop-through) Trilevel SYNC 0.6 Vp-p, 75 Ω, sync negative
HD	Black burst NTSC: 0.286 Vp-p, 75 Ω, sync negative PAL: 0.3 Vp-p, 75 Ω, sync negative Selecting HD or SD in a menu
SD	
DIGITAL I/O (AES/EBU) INPUT	BNC (6) CH1/2 to CH11/12 AES/EBU format, unbalanced
AUDIO INPUT CUE (SRW-5500 only)	XLR, 3-pin, female (1)
TIME CODE IN	XLR 3-pin, female (1) 0.5 to 18 Vp-p, 10 kΩ, balanced

Output connectors

HD SDI OUTPUT	
A	BNC (3, MONITOR with superimposed text) SDI (1.485 Gbps) (conforms to SMPTE 292M/BTA S004B)
B (OPTION)	BNC (3) (when the optional HKSR-5003 is installed)
SD SDI OUT	BNC (3, MONITOR with superimposed text)
SD OUT	
COMPOSITE (SUPER)	1.0 Vp-p, 75 Ω, sync negative
SYNC	Black burst 0.286 Vp-p, 75 Ω, sync negative
FORMAT CONV. OUT (OPTION)	(when the optional HKSR-5001 is installed) BNC (2, with superimposed text)
FC OUT B (OPTION)	(when the optional HKSR-5001 is installed) BNC (2, with superimposed text)
HD REF. OUT	BNC (2)
1125 SYNC	Tri-level SYNC 0.6 Vp-p, 75 Ω, sync negative
DIGITAL I/O OUTPUT (AES/EBU)	BNC (6) CH1/2 to CH11/12 AES/EBU format, unbalanced
AUDIO OUTPUT	XLR 3-pin, male (5) CH1, CH2, CH3, CH4 and CUE (CUE: for HDCAM or Digital Betacam playback only) +4 dBm, (with 600 Ω load), low impedance, balanced

MONITOR OUTPUT L, R	XLR, 3-pin, male (2) +4 dBm (with a 600 Ω load), low impedance, balanced
TIME CODE OUT	XLR, 3-pin, male (1) 2.2 Vp-p, low impedance, balanced
PHONES	JM-60 stereo phone jack – ∞ to –12 dBu (with an 8 Ω load), unbalanced

Remote connectors

ETHERNET	RJ-45 modular jack
REMOTE 1-IN(9P)	D-sub 9-pin, female
REMOTE 1-I/O(9P)	D-sub 9-pin, female
VIDEO CONTROL	D-sub 9-pin, female (for optional HKDV- 900)
REMOTE 2 PARALLEL I/O(50P)	D-sub 50-pin, female

Accessories supplied

Operation Manual (English version \times 1, Japanese version \times 1)
Installation Manual (English version \times 1, Japanese version \times 1)
CD-ROM (1)

Optional accessories

HKSR-5001 Format Converter Board
HKSR-5002 Digital Betacam Playback Board
HKSR-5003 RGB Record Playback Board
RMM-110 Rack Mount Adaptor
BCT-HD12CL Cleaning Cassette

Recommended accessories

For details about recommended accessories, contact your Sony service representative.

Memory card adaptor

MSAC-PC4 Memory Stick PC Card Adaptor or equivalent

Parallel/serial converters

HD-694 ASTRO DESIGN Corporation or equivalent

XLR/BNC adaptors

BCJ-XP-TRA from CANARE Corporation or equivalent

For optionally available AC power cords, refer to the supplied Installation Manual.

Design and specifications are subject to change without notice.

Notes

- Always make a test recording, and verify that it was recorded successfully.
SONY WILL NOT BE LIABLE FOR DAMAGES OF ANY KIND INCLUDING, BUT NOT LIMITED TO, COMPENSATION OR REIMBURSEMENT ON ACCOUNT OF FAILURE OF THIS UNIT OR ITS RECORDING MEDIA, EXTERNAL STORAGE SYSTEMS OR ANY OTHER MEDIA OR STORAGE SYSTEMS TO RECORD CONTENT OF ANY TYPE.
- Always verify that the unit is operating properly before use. SONY WILL NOT BE LIABLE FOR DAMAGES OF ANY KIND INCLUDING, BUT NOT LIMITED TO, COMPENSATION OR REIMBURSEMENT ON ACCOUNT OF THE LOSS OF PRESENT OR PROSPECTIVE PROFITS DUE TO FAILURE OF THIS UNIT, EITHER DURING THE WARRANTY PERIOD OR AFTER EXPIRATION OF THE WARRANTY, OR FOR ANY OTHER REASON WHATSOEVER.

Error Messages and Warning Messages

Error Messages

When the unit ceases to operate correctly due to malfunction or an internal system error, the alarm will sound and an error message will be displayed on the display.

Only one message will be displayed even when multiple errors occur, but the error log menu keeps a history of the errors.

For more information about error messages, refer to the Maintenance Manual.

After the error occurs, eliminate the cause of the error and turn the unit back on. If the error message appears again when the unit is turned on, contact your Sony representative.

For more information about eliminating errors, refer to the Maintenance Manual (Volume 1).

Protection mode

To protect the tape and the mechanical parts of the VTR, the servo control system automatically stops tape transport and the drum motor and enters protection mode when an error occurs.

Cassettes may not be inserted or ejected during protection mode.

Note

When a cassette is stuck in the unit because of protection mode, make sure to disconnect the power before removing the cassette manually.

For information about removing cassettes manually, refer to the Maintenance Manual (Volume 1).

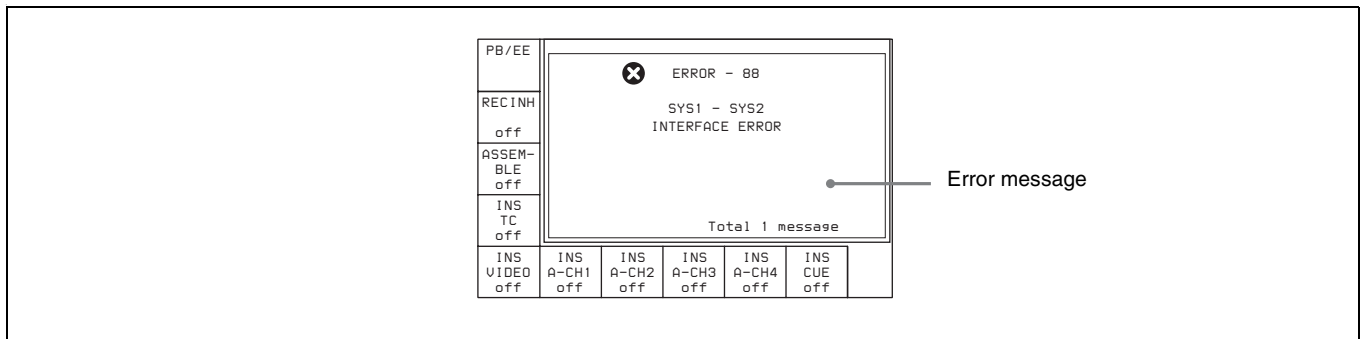

Item number	Display	Meaning
01	REEL SLACK THREAD ERROR	Tape slack was detected during threading or unthreading.
02	REEL SLACK SHTL ERROR	Tape slack or a broken tape was detected during search, fast forward, or rewind.
03	REEL SLACK VAR ERROR	Tape slack, a broken tape, or an S-side reel or T-side reel lock was detected during recording or playback.
04	REEL SPEED ERROR	Tape transport speed error was detected during forward winding or rewinding.
05	REEL FG ERROR	When a cassette was inserted, a fault in the S-side reel or T-side reel operation was detected.
06	OVER TENSION	During recording or playback, excess tension was detected.
07	CAPSTAN ERROR	A capstan motor operation fault was detected.
08	DRUM ERROR	A drum motor operation fault was detected.
09	THREAD TIME OVER	A fault was detected in a threading or unthreading operation.
0A	FULL TOP ERROR	When threading, a failure of the tape beginning processing to terminate was detected.
10	HUMID DETECT	Condensation was detected.
11	TOP END BOTH DETECT	The tape beginning and tape end were detected at the same time.

Item number	Display	Meaning
12	TAPE TOP ERROR	A tape beginning sensor fault was detected.
13	TAPE END ERROR	A tape end sensor fault was detected.
14	FAN MOTOR ERROR	A cooling fan motor operation fault was detected.
20	CC TIME OVER	A fault was detected in a cassette compartment raising or lowering operation.
21	SHIFT TIME OVER	A fault was detected movement of the reel table to adjust for cassette size.
22	POSITION BOTH DETECT	The reel table was detected in the L cassette position and S cassette position at the same time.
23	THREAD BOTH DETECT	The threading end and unthreading end were detected at the same time.
93	DR IF ERROR	A communications error between the SV CPU (board SS-95) and drum CPU (board DR-508) was detected.
97	NVRAM CHECK SUM ERROR	An operation fault was detected in the servo system NV-RAM (board DR-508).
FF	SV UNDEFINE ERROR	Undefined SV error was detected.
A0	SY UNDEFINE ERROR	Undefined SY error was detected.
A2	SY1-SY2 DPRAM ERROR	A DPRAM (board SS-95) operation fault between SYS1 and SYS2 was detected.
A5	SY-FC DPRAM ERROR	A DPRAM (board FC-91) operation fault between SYS1 and FC was detected.
A8	SY NVRAM CHECK SUM ERROR	A SYS NVRAM (board SS-95) operation fault was detected.
B8	SY1-SY2 INTERFACE ERROR	A SYS CPU communications fault was detected.
B9	SY-SV INTERFACE ERROR	An SV CPU communications fault was detected.
BA	SY-EQ INTERFACE ERROR	An EQ CPU communications fault was detected.
BB	SY-FC INTERFACE ERROR	An FC CPU communications fault was detected.
BC	SY-50PIN INTERFACE ERROR	A communications fault with the 50-pin CPU was detected.

Warning Messages

When one of the problems described below is detected, a warning mark is displayed in the upper left corner of the display. Operation can continue even when the mark is flashing.

If you press the SFT button (*see page 20*) and the DIAG button (*see page 18*) when the mark is flashing, an information display appears, showing a warning message.

Note

The warning messages can be viewed in any menu except the CUE or SET UP menu.

Only one message will be displayed even if there are multiple messages. The number of errors appears at the lower right, and you can check the messages using the ↑ and ↓ buttons.

A history of errors is kept in the error log menu.

For more information about warning messages, refer to the Maintenance Manual.

Use the displayed warning information to eliminate the cause of the warning.

For more information about eliminating the cause of warning, refer to the Maintenance Manual.

To automatically display a warning message

Whenever a warning occurs, change the setting of the VTR SETUP menu item 120 “WARNING DISPLAY” to “on”.

To clear a warning message

To cancel the display of a warning message, see “Clearing warning messages” on page 139.

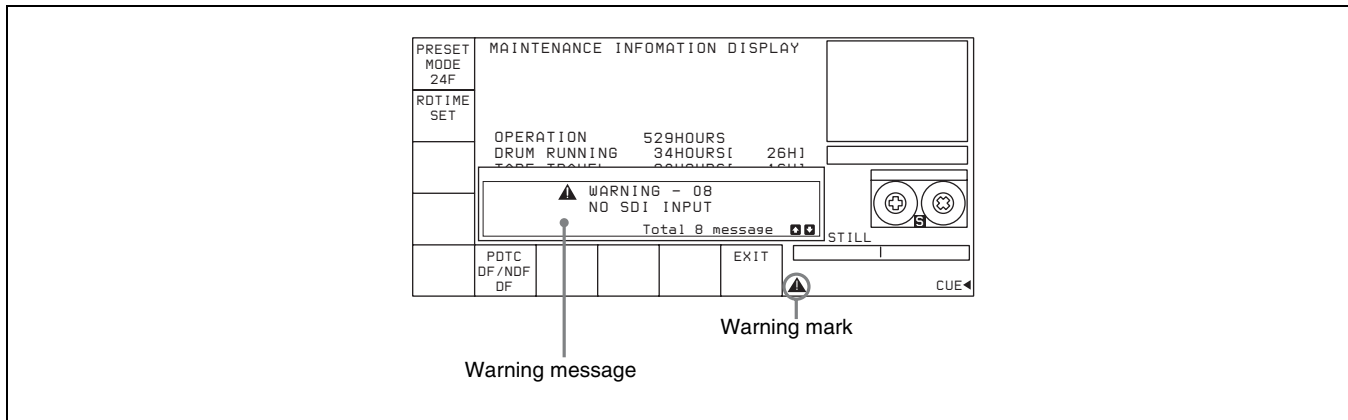

Item number	Display	Meaning
01	NO EXTERNAL REFERENCE	There is no reference signal on the selected REF. INPUT connector. The VTR is using an internal reference signal.
02	LOST LOCK	Capstan servo lock was lost during playback, recording, or editing.
03	NO EXTERNAL REFERENCE ON FC	When the VTR SETUP menu item A05 “PD EXT SD REF LOCK MODE” is set to “lock1” or “lock2”, no external SD reference signal is input.
04	HD & SD REF ASYNCHRONOUS	When the VTR SETUP menu item A05 “PD EXT SD REF LOCK MODE” in is set to “lock1” or “lock2”, HD reference signal and external SD reference signal are not synchronized.
05	PLL UNLOCK ON FC	The PLL of the HKS-5001 is not locked on the reference signal.
08	NO SDI INPUT	An SDI input signal cannot be detected.
0B	VIDEO DATA ERROR	The video data channel condition indicator is lit red.
0F	AUDIO DATA ERROR	The audio data channel condition indicator is lit red.
10	VITC NOT READ	VITC cannot be correctly read from the tape.
11	AUDIO PLL UNLOCKED	Audio lock generator PLL not locked to the video reference signal.
14	NO PB RF SIGNAL	Playback heads cannot correctly read digital data from the tape.
15	INCONSISTENT EMPHASIS	Emphasis information on the tape is inconsistent with the system emphasis status.
16	INCONSISTENT FORMAT OF META DATA	The meta data being input and the meta data recorded on the tape have different formats.
17	PB FREQUENCY IS UNSUITABLE	The cassette is ejected automatically in line with the setting of the VTR SETUP menu item 018 “AUTO EJECT LEVEL” because the system frequency of the VTR and the frequency of the signal recorded on the tape do not match.
19	NO A1/A2 INPUT	No carrier detected on digital audio input on channels 1 and 2
1A	NO A3/A4 INPUT	No carrier detected on digital audio input on channels 3 and 4
1B	NO A5/A6 INPUT	No carrier detected on digital audio input on channels 5 and 6.
1C	NO A7/A8 INPUT	No carrier detected on digital audio input on channels 7 and 8.
1D	NO A9/A10 INPUT	No carrier detected on digital audio input on channels 9 and 10.
1E	NO A11/A12 INPUT	No carrier detected on digital audio input on channels 11 and 12.
21	REC INHIBIT MODE	The menu settings are to a mode inhibiting recording, or the tape format does not allow recording.
22	CASSETTE REC INHIBIT	The cassette is set to inhibit recording.



Item number	Display	Meaning
2D	INVALID SDI DATA	SDI input signal data is invalid.
34	NO CASSETTE COMPARTMENT MODE	The cassette compartment does not operate because the VTR is in "no cassette compartment" mode.
3B	NO LTC REPRODUCED	LTC signal not detected on the tape.
52	NO SUPPORTED PB FORMAT	The recording format cannot be played back by this unit.
53	SYSTEM MISMATCH	The tape cannot be played with the current system settings.
55	VIDEO PLL UNLOCKED	Video lock generator PLL not locked to the video reference signal.
59	INPUT AUDIO DATA MISMATCH 32.000K	The input audio frequency is wrong.
5A	INPUT AUDIO DATA MISMATCH 47.056K	The input audio frequency is wrong.
61	TELEFILE MEMORY IS FULL	The remaining capacity of the Tele-File is low, and therefore the next recording will overwrite old data.
62	NO AREA FOR TELEFILE DATA ADDITION	There is no space at all in the Tele-File.
63	INVALID FORMAT TELEFILE	Parts of the Tele-File format are wrong.
64	TELEFILE DATA WRITE FAIL	A write to Tele-File error occurred.
65	NO TELEFILE LABEL	The Tele-File could not be recognized, and therefore the cassette is ejected (HDCAM-SR only).
66	TELEFILE DATA WRITE IS INHIBITED	Recording or editing was started with the Tele-File in overall write inhibit mode.
67	TELEFILE DATA READ FAIL	A Tele-File read error occurred.
71	INVALID FORMAT CONVERSION	The settings do not allow format conversion.
72	REC/EDIT DISABLE CASSETTE FORMAT	The inserted cassette cannot be recorded or edited because of system settings (recording format, system line, etc). This display applies only to HDCAM/HDCAM-SR cassettes (SRW-5500 only).
73	NO REFERENCE INFORMATION	Cannot lock because there is no 30 frames/second reference information in 720/59.94p HD SDI input signals.
74	ASYNCHRONOUS VIDEO INPUT	When external sync is selected, the external sync signal and the HD SDI INPUT signal are more than $\pm 5H$ out of phase.
77	AUTO CUEUP ABORT	Auto cue-up was aborted because the target cue-up time code is 1 second or more away from the current time code.

Error Log Menu

The time and time codes of errors and warnings occurring during operation can be displayed in a list form in the display. (Maximum listing is 99 items.)

To open the error log menu

Press the SFT button (*see page 20*) and the DIAG button (*see page 18*), then press the **[F2]** (ERR LOG) button.

PAGE TOP	ERROR LOG '03/06/02 10:27:28				
	TOTAL 99				
PAGE END	95.00:00:00:00 (W) 1B				
	NO A5/A6 INPUT				
FULL MSG	96.00:00:00:00 (W) 1C				
	NO A7/A8 INPUT				
	97.00:00:00:00 (W) 1D				
	NO A9/A10 INPUT				
ALL CLEAR	95.00:00:00:00 (W) 1E				
	NO A11/A12 INPUT				
WARN- NG on	ERROR on	CONDI- TION on		TIME TC	EXIT

Button	Display	Function	Setting
[F1]	PAGE TOP	Move to the top page	
[F2]	PAGE END	Move to the page containing the last message	
[F3]	FULL MSG	Display in full the message selected with the cursor	
[F4]	ALL CLEAR	Clear messages (LOG DATA)	
[F5]	WARNING	Display warning messages	on, off
[F6]	ERROR	Display error messages	on, off
[F7]	CONDITION	Display condition messages	on, off
[F9]	TIME	Toggle between time code and real time display	TC, REAL
[F10]	EXIT	Return to display of maintenance information	
ALT/[F8]	CANCEL EDIT	Display the CANCEL EDIT screen	
ALT/[F9]	REAL TIME	Display the REAL TIME screen	

For more information about error log menu settings, refer to the Maintenance Manual.

SUMMER: daylight saving time (one hour ahead of normal time)

Clearing warning messages

- 1 Press the ALT/[F8] (CANCEL EDIT) buttons.
- 2 Select the message to be cleared using the ↑ and ↓ buttons.
- 3 Press the [F2] (MARK) button.

An asterisk “*” will appear in front of the message. The message will not be displayed or saved.

To cancel clearing

Select the warning message you want to cancel clearing, and press the [F2] (MARK) button.

Adjusting the clock

Press the ALT/[F9] (REAL TIME) buttons in the error log menu and use the setting below.

To get current time codes

Hold down the SFT button and press the [F5] (GET TC) button.

To set the data and time

Hold down the SFT button and press the [F6] (SET) button. Use the ← and → buttons to move the bar to the location to be adjusted.

Use the numeric buttons to change the value.

To adjust minutes and second to zero

Hold down the SFT button and press [F8] (ZERO) button.

To select daylight saving time and normal time

Hold down the SFT button and press [F9] (SEASON) button.

STANDARD: normal time

Note

Changing between normal and daylight saving times changes the current time by one hour. Even if the change crosses midnight, the current date is not changed.

Glossary

AES/EBU format

A standard format for the transfer of digital audio signals. In this format, two audio signals can be input/output through one XLR-type connector.

Assemble editing

An edit mode for adding new scenes to the end of previously recorded scenes. New video signals are recorded for each control signal, but continuity with the control signal preceding the edit point is maintained electrically. Because assemble editing in the middle of a scene will cause a break in the video image at the end of the insertion, this is not a practical method for inserting new video data. This should be done with insert editing.

See also Insert editing.

Bridging connection

A connection that allows a signal input to an input terminal to pass through the unit and exit from an output terminal for input to a third piece of equipment.

Capstan

A drive mechanism that moves the tape at a specified speed. Its rotation is normally synchronized with a reference sync signal.

Color frame

A color subcarrier phase having one cycle that consists of two frames (four fields) in the NTSC format.

Color frame locking

A procedure in which the time code frame value is set to an odd number for the first and second color fields, and to an even number for the third and fourth color fields.

Color framing

A method to maintain color subcarrier phase continuity by performing editing in two-frame units in order to achieve stable video without horizontal fluctuation at the edit points when editing downconverted composite video signal.

Component video signal

A video signal that consists of a luminance signal (Y) and two chrominance (color-difference) signals (R-Y, B-Y).

Composite video signal

A signal that consists of video (luminance and color sub carrier), sync (horizontal and vertical), and color burst signals.

Condensation

Moisture that collects on the head drum of the tape transport mechanism, causing damage to the tape and malfunction of the VTR.

CTL

Abbreviation for control signal. A pulse signal that can be counted, to determine the number of frames, and therefore the tape's running time. Used mainly for adjusting the tracking position of video heads, and to achieve time code continuity during continuous recording. This signal is recorded on a longitudinal tape track.

Cue point

A point used to mark the beginning of a section of tape so that it can be located for later playback or editing.

Drop frame mode

When the field frequency of this unit is 59.94 Hz, the actual number of frames per second is approximately 29.97, while the time code value advances one second every 30 frames. In drop frame mode, the time code is advanced such a way that this difference in the value between real time and the time codes is corrected. Specifically, two frames are skipped at the beginning of each minute, except for every tenth minute, so that the frame value for time codes matches that for real time. See also Non-drop frame mode.

E-E mode

Abbreviation for Electric-to-Electric mode. In this mode, the signals are passed through the VTR's electronics before output but do not pass through the magnetic converter circuits such as the tape and head circuits. This mode is used for confirming input signals or adjusting the input level.

Effect edit mode

When editing a tape using a switcher or when editing special effects, the pixels comprising the picture are often not dubbed to the same positions as those of the original. In the case of repeated dubbings, this shifting of pixels produces an accumulation of calculation errors during the compression/expansion process; this may result in an increase in low-level noise within the signal. The effect edit mode minimizes the production of this noise. Note, however, that a slight loss in picture resolution may be observed in this mode.

Emphasis

Emphasizing the high frequencies of a signal before processing (pre-emphasis) and de-emphasizing those high frequencies before output (de-emphasis). This reduces deterioration of the signal-to-noise ratio in the high frequency range.

External synchronization

A method to maintain color subcarrier phase continuity by performing editing in two-frame units in order to achieve stable video without horizontal fluctuation at the edit points. For editing, a recorder VTR and a player VTR (or source VTR) are used, and external synchronization is commonly used to ensure that the operation timing control signals and time reference signals are synchronized.

Insert editing

An edit mode for inserting new scenes into the middle of previously recorded scenes. CTL signals previously recorded on the tape are used. Consequently, this mode cannot be used for blank tapes. This mode assumes that CTL signals have somehow be recorded to the tape already.

See also Assemble editing.

Longitudinal time code

See LTC.

LTC

Abbreviation for Longitudinal Time Code. This is the time code recorded onto a longitudinal track of the tape. During the playback of still pictures, LTC cannot be read since the tape is not moving. During slow playback, the LTC output is so small that it may not be read correctly, depending on the playback speed.

See also VITC.

Non-drop frame mode

In this mode, drop frame mode processing is not performed. Since there is no frame cutting, a discrepancy of about 86 seconds occurs each day (in the case of a field frequency of 59.94 Hz) which causes problems when editing programs in units of seconds using the number of frames as a reference.

See also Drop frame mode.

Preroll

The rewinding of a video tape in the player or recorder VTR by a certain length before an edit point, allowing the tape to attain a stable speed at the edit point and synchronization with the other video tape during editing.

Reference video signal

A video signal containing a sync signal or sync and burst signal, used as a reference for synchronizing video equipment.

Servolocking

The locking of the phase and speed of a VTR's head drum rotation and tape transport to a reference signal during recording and playback.

Standby-off mode

A mode in which head drum rotation is stopped and tape tension is released, and thus the VTR is not ready for immediate recording and playback. This mode alleviates the tape and video heads from wear or damage.

An Standby-on mode

A mode in which the head drum rotates with the tape wrapped around it, and thus the VTR is ready for immediate recording or playback. The VTR enters standby-off mode after remaining in standby-on mode for a specified length of time to prevent wear or damage to the tape and video heads.

Time code

A digital signal recorded on the video tape that supplies information such as hour, minute, second and frame number for each frame to facilitate the setting of edit points or searching for specific scenes on the tape.

There are two types of time codes: SMPTE (for the NTSC color system) and EBU (for the PAL/SECAM color system); and two time code recording formats: LTC (longitudinal time codes) which are CTL signals and audio signals simultaneously recorded longitudinally on the tape and VITC (vertical interval time codes) which are recorded on the video signal track.

Tracking

The synchronizing of the head drum rotation phase and tape transport phase during playback and recording. Tracking is adjusted to eliminate picture instability when playing back material recorded on another VTR.

User bits

A recordable 32-bit section in each time code on a video tape for recording such information as the recording year, month, and day, and the tape or program ID number.

Vertical interval time code

See VITC.

VITC

Abbreviation for Vertical Interval Time Code. This is a time code recorded on a video signal track during the vertical blanking interval. This VTR writes this time code in the AUX data area in the video signals. It can be read correctly even during slow or still picture playback.

See also LTC.

Menu List

This section describes all of the VTR SETUP menu items. The VTR SETUP menu items are divided into the following categories by the function.

- Items relating to VTR operations (Nos. 001 to ...)
- Items relating to operation panels (Nos. 101 to ...)
- Items relating to the remote interface (Nos. 201 to ...)
- Items relating to editing (Nos. 301 to ...)
- Items relating to prerolling (Nos. 401 to ...)
- Items relating to recording protection (Nos. 501 to ...)
- Items relating to the time code (Nos. 601 to ...)
- Items relating to the video control (Nos. 706 to ...)

- Items relating to the audio control (Nos. 807 to ...)
- Items relating to digital process (Nos. 902 to ...)
- Items relating to pulldown control (Nos. A01 to ...)
- Other items (Nos. T01 to ...)

For VTR SETUP menu operations, see “4-7-1 VTR SETUP Menu” on page 99.

In the “Setting” column of the table, the factory default settings are indicated by an enclosing box.

Items Relating to VTR Operations (Nos. 001 to ...)

Item number	Item	Setting	Function
001	PRE-READ	<input type="checkbox"/> off on video only	Selects the pre-read (read-before-write) mode for insert editing. off: No pre-read operation on: Pre-read operation video only: Pre-read operation for video only
002	REC INHIBIT select	<input type="checkbox"/> off all/crash REC/video CTL/audio CTL casst	Selects the record inhibit mode. off: Recording is enabled. (The REC INHIBIT indicator does not light.) all/crash REC/video CTL/audio CTL: Recording is inhibited on the set channels. The scope of inhibiting recording is determined by menu item 003. casst: When the recording protection plug on the cassette is pushed in, this setting is displayed. This setting cannot be selected.
003	REC INHIBIT AREA select	<input type="checkbox"/> all crash REC video/CTL audio/CTL casst	Selects the scope to which inhibiting recording applies. all: All recording is inhibited. (The REC INHIBIT indicator lights.) crash REC: The normal recording mode is inhibited. Use this setting when you wish to record in assemble editing or insert editing only. video/CTL: Recording of video and CTL is inhibited. audio/CTL: Recording of audio and CTL is inhibited. casst: When the recording protection plug on the cassette is pushed in, this setting is displayed. This setting cannot be selected. The REC INHIBIT indicator lights or flashes to indicate the state of the recording inhibit mechanism on the cassette. <i>For details, see item 104.</i>

Item number	Item	Setting	Function
005	SERVO/AV REFERENCE select	<input type="checkbox"/> input auto external	The servo reference is determined by the following menu. input: The reference signal is obtained from the HD SDI INPUT A/B connectors. auto: During recording and in the edit preset state, the reference signal is obtained from the HD SDI INPUT A/B connectors. When item 001 is not set to "off", the reference signal is always external. In all other cases, the servo operates using the signal selected in item 006 as the reference signal. If the signal selected in item 006 is not present, the servo operates using an internal reference signal. external: The servo reference signal is always external.
006	EXTERNAL REFERENCE select	<input type="checkbox"/> extrn HD extrn SD	When item 005 is set to "external", this selects the signal used as reference by this unit. extrn HD: The signal input to the REF. INPUT 1 connector is used as the tri-level HD reference signal for playback and audio signal recording. extrn SD: The signal input to the REF. INPUT 1 connector is used as the SD reference signal for playback and audio signal recording.
007	SYNC PLAY	<input type="checkbox"/> off on	This is the mode for automatic correction at the start of playback. In sync play mode, for example when playing back the VTR from a preroll point, the IN point is reached after exactly the preroll time has elapsed. off: Selects normal playback mode. on: Activates the sync play function for playback. Note In sync play mode, the time after the tape transport starts until the video and sound appear is longer than in the normal playback mode.
008	LOCAL FUNCTION ENABLE	all disable <input type="checkbox"/> stop&eject all enable local key map	When this unit is used in remote control mode, this selects which buttons on the control panel operate. all disable: All switches and buttons are disabled. stop & eject: Only the STOP and EJECT buttons operate. all enable: All switches and buttons except the RECORDER and PLAYER buttons are enabled. local key map: Only the buttons enabled in item 009 are operational.

Item number	Item	Setting	Function
009	LOCAL KEY MAP		Sets the LOCAL KEY MAP.
	Sub items		
	STOP	<input type="checkbox"/> disable <input type="checkbox"/> enable	disable: The STOP button is disabled in remote control mode. enable: The STOP button operates in remote control mode.
	PLAY	<input type="checkbox"/> disable <input type="checkbox"/> enable	disable: The PLAY button is disabled in remote control mode. enable: The PLAY button operates in remote control mode.
	REC/EDIT	<input type="checkbox"/> disable <input type="checkbox"/> enable	disable: The REC/EDIT button is disabled in remote control mode. enable: The REC/EDIT button operates in remote control mode.
	STANDBY	<input type="checkbox"/> disable <input type="checkbox"/> enable	disable: The STANDBY button is disabled in remote control mode. enable: The STANDBY button operates in remote control mode.
	EJECT	<input type="checkbox"/> disable <input type="checkbox"/> enable	disable: The EJECT button is disabled in remote control mode. enable: The EJECT button operates in remote control mode.
	JOG	<input type="checkbox"/> disable <input type="checkbox"/> enable	disable: The JOG button is disabled in remote control mode. enable: The JOG button operates in remote control mode.
	SHUTTLE	<input type="checkbox"/> disable <input type="checkbox"/> enable	disable: The SHUTTLE button is disabled in remote control mode. enable: The SHUTTLE button operates in remote control mode.
	VAR	<input type="checkbox"/> disable <input type="checkbox"/> enable	disable: The VAR button is disabled in remote control mode. enable: The VAR button operates in remote control mode.
	PREROLL	<input type="checkbox"/> disable <input type="checkbox"/> enable	disable: The PREROLL button is disabled in remote control mode. enable: The PREROLL button operates in remote control mode.
	PREVIEW/ REVIEW	<input type="checkbox"/> disable <input type="checkbox"/> enable	disable: The PREVIEW/REVIEW button is disabled in remote control mode. enable: The PREVIEW/REVIEW button operates in remote control mode.
	AUTO	<input type="checkbox"/> disable <input type="checkbox"/> enable	disable: The AUTO button is disabled in remote control mode. enable: The AUTO button operates in remote control mode.
	INPUT CHECK	<input type="checkbox"/> disable <input type="checkbox"/> enable	disable: The INPUT CHECK button is disabled in remote control mode. enable: The INPUT CHECK button operates in remote control mode.
	MENU&CURSOR	<input type="checkbox"/> disable <input type="checkbox"/> enable	disable: The menu buttons and the cursor control buttons are disabled in remote control mode. enable: The menu buttons and the cursor control buttons operate in remote control mode.
MONITOR	<input type="checkbox"/> disable <input type="checkbox"/> enable	disable: The MONITOR button is disabled in remote control mode. enable: The MONITOR button operates in remote control mode.	

Item number	Item	Setting	Function
017	PB/EE SELECT MENU		Selects output video and audio signals.
	Sub items		
	STAND BY OFF	PB/MU EE/EE	Selects the video and audio output signals in the “standby off” mode. PB/MU: The playback video signal is output. The audio output is muted. EE/EE: The input video and audio signals are output.
	STAND BY ON	PB/MU EE/EE EE/MU	Selects the video and audio output signals in the “standby on” mode. PB/MU: The playback video signal is output. The audio output is muted. EE/EE: The input video and audio signals are output. EE/MU: The input video signal is output. The audio output is muted.
	REC	PB/PB EE/EE	Selects the video and audio output signals during recording. PB/PB: The playback video and audio signals are output. EE/EE: The input video and audio signals are output.
	SHUTTLE	PB/MU EE/EE PB/PB	Selects the video and audio output signals during shuttle playback. PB/MU: The playback video signal is output. The audio output is muted. EE/EE: The input video and audio signals are output. PB/PB: The playback video and audio signals are output.
	JOG	PB/PB PB/MU	Selects the video and audio output signals during jog playback. PB/PB: The playback video and audio signals are output. PB/MU: The playback video signal is output. The audio output is muted.
	VAR	PB/PB PB/MU	Selects the video and audio output signals during “variable” playback. PB/PB: The playback video and audio signals are output. PB/MU: The playback video signal is output. The audio output is muted.
018	AUTO EJECT LEVEL1 (HDCAM-SR)	off LEVEL1 LEVEL2	Selects the condition under which the cassette is automatically ejected after being played back for a few seconds. When the cassette is ejected in accordance with this setting, the warning message “17 PB FREQUENCY IS UNSUITABLE” appears in the display. off: The cassette is not ejected. LEVEL1: When a tape without video playback compatibility is played back, the cassette is automatically ejected. There is no playback compatibility between 4:2:2 format, 4:4:4 format, and 720P format. LEVEL2: The cassette is ejected when the field frequency, PsF mode, or interlace mode of the tape differs from that of the VTR.

Item number	Item	Setting	Function
019	AUTO EJECT LEVEL2 (HDCAM)	<input type="checkbox"/> off LEVEL1 LEVEL2 LEVEL3	Selects the tape conditions under which a cassette is automatically ejected in playback (after approx. 3 seconds playback). When the cassette is automatically ejected, a warning message "17 PB FREQUENCY IS UNSUITABLE" appears. off: The cassette is not ejected. LEVEL1: When a tape without audio playback compatibility is played back, the cassette is automatically ejected. There is no playback compatibility between playback frame rates of 24, 25 fps and 30 fps. (There is compatibility for PsF, interlacing, or 0.1% discrepancy.) LEVEL2: Excluding a tape with compatibility for a frequency discrepancy of 0.1%, when a tape without compatibility is played back, the cassette is automatically ejected. LEVEL3: When a tape other than in the mode selected as the system is played back, the cassette is automatically ejected. (This includes PsF, and interlace mode differences.)
020	P PLAY	<input type="checkbox"/> off on	Selects the mode for output of program play video and audio from the FC OUT connectors. off: Use the normal mode. on: Program play video and audio is output.

Items Relating to Operation Panels (Nos. 101 to ...)

Item number	Item	Setting	Function
101	SELECTION FOR SEARCH DIAL ENABLE	dial direct <input type="checkbox"/> via search key	Determines how the unit is set to search mode. dial direct: The unit enters search mode when you rotate the search dial in all modes except recording and edit modes. via search key: The unit enters search mode when you press the SHUTTLE, JOG or VAR button.
102	REFERENCE SYSTEM ALARM	off <input type="checkbox"/> on	Specifies where or not to display a warning when audio/video reference signal selected in item 005 is not present or out of phase with the input video signal. off: No warning is displayed. on: Warning is displayed by flashing STOP button.
104	REC INHIBIT LAMP FLASHING	off <input type="checkbox"/> on	Specifies whether the REC INHIBIT indicator lights or flashes, when record-protect plug on the back side of the inserted cassette tape is pressed down. off: The REC INHIBIT indicator lights up. on: The REC INHIBIT indicator flashes.

Item number	Item	Setting	Function
107	JOG DIAL RESPONSE	type1: -1 to +1 type2: -2 to +2 type3: -2 to +2	<p>Selects the tape speed (VTR command) characteristics for search dial rotation.</p> <p>TYPE1: Tape speed changes linearly in a range of -1 to +1 times normal tape speed.</p> <p>TYPE2: Tape speed changes in a range of -2 to +2 times normal tape speed as shown below in TYPE2. (Tape speed does not change when the search dial is within a range of ± 1 times normal tape speed.)</p> <p>TYPE3: Tape speed changes linearly in a range of -2 to +2 times normal tape speed as shown below in TYPE3.</p>
109	KEY INHIBIT	off on	When this is set to ON, the "KEYINH" indicator in the information display appears, and the editing control block, tape transport control block, search control block, and REMOTE button are disabled.
111	VARIABLE SPEED LIMIT IN KEY PANEL CONTROL	off (-1 to +2) on (0 to +1)	<p>Sets the tape speed range during variable-speed (VAR) playback on the control panel of this unit.</p> <p>off (-1 to +2): The range of the tape speed is -1 to +2 times normal speed.</p> <p>on (0 to +1): The range of the tape speed is 0 to +1 time normal speed.</p>
112	CTL LOCK IN VAR/ SHTL	off -1/-0.5/0.5/1.0/2.0	<p>CTL locks the tape transport during variable-speed playback or shuttle playback.</p> <p>off: CTL does not lock.</p> <p>-1/-0.5/0.5/1.0/2.0: CTL locks the tape transport at speeds of -1, -0.5, 0.5, 1.0, and 2.0 times normal speed.</p>
113	DT MODE	field (-1 to +1) frame	<p>Sets the DT operation mode.</p> <p>field (-1 to +1): Enters the field playback mode (Field DT mode) when the tape speed is -1 to +1 times normal speed.</p> <p>frame: Enters the frame playback mode (Frame DT mode) when the tape speed is +1 to +2 times normal speed.</p> <p>frame: Enters the frame playback mode (Frame DT mode).</p>
114	POWER-ON MENU select	HOME menu TC menu VIDEO menu AUDIO menu CUE menu PF1 menu PF2 menu ALT+PF1 menu ALT+PF2 menu	Selects the menu displayed when the unit is powered on.
115	KEY BEEP	high mid low off	Selects the volume of the key click sound.
116	ALARM BEEP	high mid low off	Selects the volume of the alarm sound.

Item number	Item	Setting	Function
117	SCREEN SAVER	3 min 10 min 60 min <input type="checkbox"/> off	Selects the time after which the screen saver function operates for the color display.
118	SCREEN SAVER S	<input type="checkbox"/> off on	Set the screen-saver for the information display. off: Do not use screen-saver. on: Use screen-saver. The information display reverses at regular intervals.
120	WARNING DISPLAY	<input type="checkbox"/> off on	Selects whether warning messages should be displayed in the lower part of the time code display for the HOME menu, the TC menu, the PF1 menu, and the PF2 menu. off: Do not display warning messages. on: Display warning messages. Notes <ul style="list-style-type: none"> No warning messages are displayed for the CUE menu, so check by viewing a menu other than the CUE menu. If LOST LOCK occurs during playback or recording, a LOST LOCK warning message is always displayed.
121	INFO DISPLAY MODE	rotation latch <input type="checkbox"/> momentary	Sets the display mode for the information display. rotation: The display automatically changes in sequence, at regular intervals. latch: Hold down the MULTI CONTROL knob and turn it to change the display, which remains unchanged when you release the knob. momentary: Hold down the MULTI CONTROL knob and turn it to change the display; after a set time interval, the display reverts to the first page.
122	MULTI CUE CLEAR by inject	<input type="checkbox"/> on off	Selects whether to erase cue point data in multi-cue mode when a cassette is inserted. on: Erase cue point data. off: Do not erase cue point data.
124	Tele-File MENU auto popup	<input type="checkbox"/> off on	Specifies whether or not the TELE FILE menu appears automatically when a cassette with a memory label is inserted. off: The TELE FILE menu does not appear. on: The TELE FILE menu appears.
125	Tele-File THREAD COUNTER clear mode	<input type="checkbox"/> not clear when format	Specifies whether or not the thread counter is reset when a memory label is formatted. not clear: The thread counter is not reset. when format: The thread counter is reset.
126	Tele-File ENTRY POINT	IN/OUT Point <input type="checkbox"/> CUE Point	Specifies whether or not to display the log data (IN and OUT points) in the TELE FILE menu. IN/OUT Point: The log data (IN and OUT points) is displayed. CUE Point: The log data (IN and OUT points) is not displayed.
127	Tele-File IN OUT Input Continue	on <input type="checkbox"/> off	Specifies whether or not to input the log data (IN and OUT points) continuously in the TELE FILE menu. on: The log data (IN and OUT points) can be input continuously. off: The log data (IN and OUT points) cannot be input continuously.
128	Tele-File Real Date/Real Time Mode	<input type="checkbox"/> without with	When recording Tele-File data, select whether to record the real date/time. without: Do not record real date/time. with: Record real date/time.

Item number	Item	Setting	Function
129	STOP CODE FUNCTION		Stop code detection mode and adjustment of stop position when a stop code is detected.
	Sub items		
	DETECT BEEP	on <input type="checkbox"/> off	on: When a stop code is detected, sound a beeper. off: When a stop code is detected, do not sound a beeper.
	DETECT STOP	on <input type="checkbox"/> off	on: When a stop code is detected, stop the tape. ("D-STOP" appears in the information display.) off: When a stop code is detected, do not stop the tape.
	STOP ADJUST	150 fr <input type="checkbox"/> 0 fr	When a stop code is detected, adjust the tape stop position from the normal stop position in the direction of the SOM point (program start point), in the range 0 to 150 frames.
	REC ADJUST	5sec 4sec <input type="checkbox"/> 3sec 2sec 1sec	Specifies how many seconds before the SOM point to start recording a stop code.
130	S-LCD DIMMER	16 to <input type="checkbox"/> 11 to 0	Adjusts the information display luminance.
131	CHANGED MENU HIGHLIGHT		Changes the display color of items whose setting has been changed.
	Sub items		
	ITEM SETTING	<input type="checkbox"/> off on	off: Changed menu setting values do not change display color. on: Changed menu setting values are displayed in yellow.
	DEFAULT SETTING	<input type="checkbox"/> off on	off: Menu numbers with changed DEFAULT values do not change display color. on: Menu numbers with changed DEFAULT values are displayed in yellow.
132	KNOB MODE	<input type="checkbox"/> set default move window	Selects the behavior of the unit when the MULTI CONTROL knob is pressed during VTR SETUP menu operations. set default: When a setting value is being selected, selects the default value. move window: Move between the item window and the window for changing values.

Items Relating to Remote Interface (Nos. 201 to ...)

Item number	Item	Setting	Function
201	REMOTE 9-PIN	<input type="checkbox"/> off on	When this is set to "on", this unit is controlled from the device connected to the REMOTE 1-IN(9P) or REMOTE 1-I/O(9P) connectors.
			<p>Note</p> <p>When this unit is controlled by a device connected to the REMOTE 1-IN(9P) or REMOTE 2 PARALLEL I/O(50P) connector, the editing control buttons and all of the tape transport buttons except STOP and EJECT are disabled. It is also possible to make a setting so that all of the buttons are disabled.</p> <p><i>For details, see item 008.</i></p>
202	REMOTE 50-PIN	<input type="checkbox"/> off on	When this is set to "on", this unit is controlled from the device connected to the REMOTE 2 PARALLEL I/O(50P) connector.

Item number	Item	Setting	Function
203	PARALLEL RUNNING	<input type="checkbox"/> disable enable	Selects whether two or more VTRs can be operated synchronized. disable: Synchronized operation is not carried out. enable: Synchronized operation is enabled. Note For synchronized operation to be possible, this item must be set to "enable" on all of the connected VTRs.
204	VIDEO REMOTE CONTROL SELECT		Make settings for control from HKDV-900/503 via the VIDEO CONTROL (9P) connector.
	Sub item		
	1 IMAGE ENHANCER	U&D UP <input type="checkbox"/> DOWN	Select whether to control the up-converter or down-converter whether controlling the image enhancer. U&D: Control both the up-converter and down-converter. UP: Control the up-converter. DOWN: Control the down-converter.
2 D2 SETUP	BLACK <input type="checkbox"/> SETUP	Select the menu item to be controlled by the SETUP dial on the HKDV-900/503 with the D2 button pressed. BLACK: Control menu item 743. SETUP: Control menu item 762. <i>For details, see items 743 and 762.</i> Note After changing the setting for this item, power off this unit or HKDV-900/503 and power it on again.	
205	REMOTE NETWORK	on <input type="checkbox"/> off	Specifies whether or not control from a network is possible. on: Allows control from a network. off: Does not allow remote control from a network.
211	REMOTE 1 PORT	<input type="checkbox"/> I & I/O IN I/O	Specifies whether to use one or both of the REMOTE 1-IN(9P) and REMOTE 1-I/O(9P) connectors on the connector panel. I & I/O: Use both the REMOTE 1-IN(9P) connector and the REMOTE 1-I/O(9P) connector. IN: Use only the REMOTE 1-IN(9P) connector. I/O: Use only the REMOTE 1-I/O(9P) connector.
212	MONITOR SELECTION FOR VTR TO VTR EDIT	<input type="checkbox"/> MAN AUTO	For editing with two SRW-5000/5500 units, specifies whether the recorder is forcibly switched to E-E mode when the PLAYER button is pressed. MAN: The recorder is not forcibly switched to E-E mode. AUTO: The recorder is forcibly switched to E-E mode, allowing you to monitor the player-side video.

Items Relating to Editing (Nos. 301 to ...)

Item number	Item	Setting	Function
301	EDIT OPERATION MODE	CG <input type="checkbox"/> normal	Selects the animation edit mode. For normal editing, use the "normal" setting. CG: Primarily for recording computer graphics, this setting allows editing by individual frames. When the edit is completed, the OUT point automatically becomes the next IN point. The next OUT point is automatically set one frame ahead of the IN point. normal: Use this setting for normal editing.
302	PREROLL TIME	0 sec : <input type="checkbox"/> 5 sec : 30 sec	This sets the preroll time. The range is from 0 to 30 seconds, in steps of 1 second. The preroll time should generally be set to at least 3 seconds, and for phase adjustment with an editing controller it is recommended to set the preroll time to at least 5 seconds.

Item number	Item	Setting	Function
303	POSTROLL TIME	0 sec : 5 sec : 30 sec	This sets the tape running time after passing the OUT point (postroll time) in automatic editing. The range is from 0 to 30 seconds, in steps of 1 second.
304	VAR SPEED RANGE FOR SYNCHRONIZATION	-1 to +2 -1.15 to +2.45	Specifies the variable tape speed range when the variable speed playback is executed by a remote control unit connected to the REMOTE 1-IN(9P) connector. -1 to +2: -1 to +2 times normal tape speed -1.15 to +2.45: -1.15 to +2.45 times normal tape speed Note When an editing control unit such as BVE-9100 is connected for DT editing, select “-1.15 to +2.45”.
305	EDIT FIELD select	1F 2F 1F/2F	Selects the start timing for editing when performing tape editing. 1F: Start editing from field 1 and end on field 2. 2F: Start editing from field 2 and end on field 1. 1F/2F: Following received timing commands. Note When the system frequency of this unit is PsF mode, the unit always operates with the 1F setting.
306	SYNCHRONIZE	accurate rough off	When this unit is used as a controller for editing control of another VTR connected through a 9-pin remote cable, this selects whether or not to carry out phase synchronization of the two VTRs, and also the editing accuracy when carrying out synchronization. accurate: Editing is carried out with an accuracy of ±0 frames. rough: Editing is carried out with an accuracy of ±1 frame. off: Synchronization is not carried out.
310	EDIT PRESET REPLACE CHANNEL SELECT		Specifies the channel of the edit preset command to be assigned with the edit preset settings for each channel.
	Sub item		
	REPLCE CH SEL	disable enable	disable: The setting in this menu is disabled and the settings in the REPLACE MODE menu and the ANALOG REPLACE menu are used. enable: The setting in this menu is enabled.
	REPLCE TR1	CH1 to [CH1] to CH12	The edit preset setting of this track turns on or off according to CH12 to the specified channel of the edit preset command.
	REPLCE TR2	CH1 to [CH2] to CH12	
	REPLCE TR3	CH1 to [CH3] to CH12	
	REPLCE TR4	CH1 to [CH4] to CH12	
	REPLCE TR5	CH1 to [CH5] to CH12	
	REPLCE TR6	CH1 to [CH6] to CH12	
	REPLCE TR7	CH1 to [CH7] to CH12	
	REPLCE TR8	CH1 to [CH8] to CH12	
	REPLCE TR9	CH1 to [CH9] to CH12	
	REPLCE TR10	CH1 to [CH10] to CH12	
REPLCE TR11	CH1 to [CH11] to CH12		
REPLCE TR12	CH1 to [CH12]		

Item number	Item	Setting	Function
311	EDIT PRESET REPLACE MODE SELECT	<input type="checkbox"/> normal <input type="checkbox"/> parallel <input type="checkbox"/> reverse <input type="checkbox"/> stereo	normal: Assigns edit preset command channels 1 to 8, to track channels 1 to 8. parallel: Assigns edit preset command channels 1 to 4, to channel pairs 1/5 to 4/8. reverse: Assigns edit preset command channels 1 to 4 to channels 5 to 8, and channels 5 to 8 to channels 1 to 4. stereo: Assigns edit preset command channels 1 to 4 to track channel pairs 1/2 to 7/8.
312	ANALOG AUDIO EDIT PRESET REPLACE Sub items ANALOG AUDIO EDIT PRESET REPLACE FOR CH9 ANALOG AUDIO EDIT PRESET REPLACE FOR CH10 ANALOG AUDIO EDIT PRESET REPLACE FOR CH11 ANALOG AUDIO EDIT PRESET REPLACE FOR CH12	<input type="checkbox"/> no def ch1 ch2 ch1+2	When the edit presets for VTR channels 9 to 12 are specified by an editor or remote controller, these are set on or off according to the analog audio edit presets. no def: Not set. ch1: Follows analog channel 1 edit preset. ch2: Follows analog channel 2 edit preset. ch1+2: Follows the edit preset for analog channel 1 or analog channel 2.
317	AUDIO EDIT MODE	<input type="checkbox"/> cut edit <input type="checkbox"/> cross fade <input type="checkbox"/> fade in/out	Specifies the type of editing for digital audio signals. cut edit: Cut editing (discontinuity in audio signal may result at the join, causing noise.) cross fade: Cross-fade (<i>see figure below.</i>) fade in/out: Fade-out and fade-in (<i>see figure below.</i>) CROSS FADE FADE IN/OUT Notes <ul style="list-style-type: none">• The “t” in the figures above is the time set by item 811.• When editing non-audio data, be sure to select “cut edit”.• Noise may be produced during the editing of certain non-audio data.
318	EDIT RETRY	<input type="checkbox"/> off <input type="checkbox"/> on	Set this item when the VTR is used as a recorder during VTR-to-VTR editing. Specifies the action taken when the recorder fails to synchronize with the player VTR. off: Editing is not executed and the VTR enters STOP mode. on: The VTR automatically repeats the editing (not more than twice).

Item number	Item	Setting	Function
320	PLAY COMMAND DELAY START TIME	-30 frame : 0 frame : +30 frame	This adjusts the time in frames required between the issue of a playback command and this unit actually beginning the execution of the command. This adjustment is useful for synchronization between VTRs with widely differing start-up timing.
321	VIDEO PREVIEW MODE	VVV VBV	During a preview operation, this selects the video signals that can be monitored on the monitor output and line output connectors. VVV(VIDEO-VIDEO-VIDEO): In the editing interval the monitored signal is the player video signal or video input (EE) signal. VBV(VIDEO-BLACK-VIDEO): In the editing interval the monitored signal is a black signal.
322	AUDIO PREVIEW MODE	SSS SMS	During a preview operation, this selects the audio signals that can be monitored on the monitor output and line output connectors. SSS: SOUND-SOUND-SOUND: In the editing interval the monitored signal is the player audio signal or audio input (EE) signal. SMS: SOUND-MUTING-SOUND: In the editing interval the audio signal is muted.

Items Relating to Prerolling (Nos. 401 to ...)

Item number	Item	Setting	Function
401	FUNCTION MODE AFTER CUE-UP	stop still	Selects the operation mode that the VTR changes to after completing a cue up operation. stop: Enters stop mode. still: Enters still-picture mode (search mode). Note When setting the standard constant on the editor and control the unit, set to "stop".
403	CUEUP BY TC	capstan only reel/capstan	This setting is only active when item 602 is set to "TC" or "UBIT". capstan only: The tape runs with the pinch ON state during cue up. (The maximum tape speed is ten times normal tape speed.) reel/capstan: The tape runs with the pinch OFF state during cue up. When the tape nears the cue up point and tape speed drops to slow, the pinch turns ON.
404	CUEUP BY CTL	capstan only reel/capstan	This setting is only active when item 602 is set to "CTL". capstan only: The tape runs with the pinch ON state during cue up. (The maximum tape speed is ten times normal tape speed.) reel/capstan: The tape runs with the pinch OFF state during cue up. When the tape nears the cue up point and tape speed drops to slow, the pinch turns ON. When this unit is controlled by an editor (BVE-2000/BVE-9100, etc), and the setting is "reel/capstan", cue up operations are done at high speed. Select "capstan only" when editing precision has priority.
405	CUE MENU DEFAULT MODE select	page mode extend mode	Selects the default mode when the CUE menu is opened. page mode: PAGE mode extend mode: EXTEND mode

Item number	Item	Setting	Function
406	CUE MENU PREROLL OFFSET	<input type="text" value="0 sec"/> : 30 sec	Sets the preroll time for a cueing up operation from the CUE menu.
407	AUTO REWIND	<input type="text" value="off"/> on	Selects the rewind mode for the end of the tape. off: The tape transport stops at the end of the tape. on: The tape is automatically rewound from the end of the tape.
408	AUTO CUE UP	<input type="text" value="off"/> on	Selects whether or not to cue up when switching from standby-off to standby-on. off: No cue-up. on: Cue up to the time code immediately before switching to standby-off.

Items Relating to Recording Protection (Nos. 501 to ...)

Item number	Item	Setting	Function
501	STILL TIMER	0.5 sec 5 sec 10 sec 20 sec 30 sec 40 sec 50 sec 1 min 2 min 3 min 4 min 5 min 6 min 7 min <input type="text" value="8 min"/> 30 min	Select the amount of time after which the VTR to automatically enters tape-protect mode, for the purpose of protecting the video head and tape. This is the time between stopping of the tape (stop mode or still-picture mode in search mode) and the change to tape-protection mode. The selectable range of time is from 0.5 second to 30 minutes.
502	TAPE PROTECTION MODE FROM SEARCH	<input type="text" value="step fwd"/> standby off tension release	Specifies the tape-protect mode to which the VTR changes from still-picture mode while searching (JOG/SHUTTLE/VAR). The unit enters automatically the specified tape-protect mode after the time specified in item 501 has elapsed. step fwd: A two-second step advance is repeated in forward direction at 1/30 times normal tape speed. standby off: The VTR enters standby off mode (standby is canceled). tension release: The VTR enters tension release mode (tape tension is released).
503	TAPE PROTECTION MODE FROM STOP	<input type="text" value="standby off"/> tension release	Specifies the tape-protect mode to which the VTR changes to from the stop mode. The unit automatically enters the specified tape-protect mode after the elapse of time specified by item 501. standby off: The VTR enters standby off mode (standby is canceled). tension release: The VTR enters tension release mode (tape tension is released).
504	DRUM ROTATION IN STANDBY OFF	<input type="text" value="off"/> on	Sets the drum rotation to "on" or "off" during standby-off mode. off: Drum rotation is stopped. on: Drum rotation continues.

Item number	Item	Setting	Function
505	STILL TENSION	normal loose	Sets the tape tension control in still-picture mode. normal: Maintains the tape tension that ensures unaffected playback even in still-picture mode. (This is the normal setting for VTR operations.) loose: Sets the tape tension lower than that of the "normal" setting after the VTR enters still-picture mode. In this case, picture playback is not ensured. (For long standbys (e.g., LMS) in still-picture mode, this setting is recommended.)
506	DRUM ROTATION TIMER	1min 2min 3min 4min 5min 10min 15min 30min 1H 2H 3H 4H 8H	When menu item 502 or 503 set to "tension release", or when menu item 504 is set to "on", the drum motor of this unit continues to rotate after tension release mode is entered. This menu item sets the time until the unit enters standby off mode and the drum motor stops rotating after entering tension release mode. The selectable time ranges from one minute to eight hours.



Items Relating to the Time Code (Nos. 601 to ...)

Item number	Item	Setting	Function
601	DF/NDF MODE select	<input type="checkbox"/> drop frame non-drop frame auto	<p>Selects the timing mode for the time code generator and the CTL counter.</p> <p>drop frame: drop frame mode (“DF” indication)</p> <p>non-drop frame: non-drop frame mode (“NDF” indication)</p> <p>auto: Drop frame / non-drop frame mode is selected automatically on the basis of the frame frequency of the unit. For 29.97 Hz drop frame mode is selected, and for 30 Hz non-drop frame mode is selected. The setting of the frame frequency mode is carried out with the <input type="checkbox"/> (OTHERS CHECK)/ <input type="checkbox"/> (SYSTEM) button in MAINTENANCE menu.</p> <p>Notes</p> <ul style="list-style-type: none"> • This setting is only active when the frame frequency of the unit is 29.97 Hz or 30 Hz. • When the <input type="checkbox"/> (TCG MODE) key is set to “regene” in TC menu, the time code generator is synchronized to the playback time code, and therefore this setting is disabled.
602	TIMER MODE select	CTL <input type="checkbox"/> TC UBIT	<p>Selects the mode for displaying time data.</p> <p>CTL: During playback the CTL signal recorded on the tape, or during recording the CTL signal being recorded on the tape, is counted, and the tape running time is displayed in hours, minutes, seconds, and frames.</p> <p>TC: The time code value read by the time code reader, or the time code value generated by the time code generator is displayed. Use item 603 to toggle between VITC and LTC.</p> <p>UBIT: The user bits inserted in the playback time code, or the user bits inserted in the time code being recorded are displayed. Use item 603 to toggle between VITC and LTC.</p>
603	TCR MODE select	<input type="checkbox"/> LTC auto VITC	<p>Selects the time code read by the time code reader during playback.</p> <p>LTC: LTC is read.</p> <p>auto: If the playback speed is in the range $\pm 1/2$ normal speed, VITC is read, and if outside this range LTC is read.</p> <p>VITC: VITC is read.</p>
604	TC2 MODE SEL	UBG TCG UBV UBR CTL VITC auto LTC <input type="checkbox"/> off	<p>Selects the time data appearing in the second line.</p> <p>UBG: Displays UBG.</p> <p>TCG: Displays TCG.</p> <p>UBV: Displays UBV.</p> <p>UBR: Displays UBR.</p> <p>CTL: Displays CTL.</p> <p>VITC: Displays VITC.</p> <p>auto: Displays VITC when the playback speed is in the range $\pm 1/2$ normal speed, and LTC if outside this range.</p> <p>LTC: Displays LTC.</p> <p>off: Does not display time data in the second line.</p>

Item number	Item	Setting	Function
605	TAPE TIMER DISPLAY	+/- 12H <u>24H</u>	Selects whether the CTL counter operates in 12-hour display mode or 24-hour display mode. +/-12H: 12-hour display mode 24H: 24-hour display mode Note In the ±12-hour display, the tens digit of the hours value is dropped.
606	TCG MODE select	<u>preset</u> regene auto	Selects the time code to which the internal time code generator synchronizes. preset: By an operation on the front panel or by remote control from a device connected to the REMOTE 1-IN(9P) connector, the initial value of the time code generated by the internal time code generator can be preset. regene: The internal time code generator is synchronized (“regene”) to the time code values read by the internal time code generator. auto: Operates in regene mode when either assemble or insert mode is selected and operates in preset mode when any other mode is selected.
607	TCG REGENE SOURCE select	SDI-LTC SDI-VITC ext-LTC int-VITC <u>int-LTC</u>	If item 606 is set to “regene”, this selects the source of the synchronization of the time code generated internally. int-LTC: When the time code played back from the time code track on the tape is used. int-VITC: When the time code played back from the “AUX data” in the video signal on the tape is used. ext-LTC: When the external time code input to the TIME CODE IN connector is used. SDI-VITC: When the VITC input to the HD SDI INPUT connector is used. SDI-LTC: When the LTC input to the HD SDI INPUT connector is used.
608	TCG/UBG REGENE MODE	<u>TC & UB</u> TC UB	Selects the regenerate signal when the time code generator is in regenerate mode (when item 606 is set to “regene”) or during auto edit mode. TC & UB: The time code signal and user bits signal are both regenerated. TC: The time code signal is regenerated. UB: The user bits signal is regenerated.
609	REC RUN/FREE RUN select	<u>free run</u> rec run	This selects the way in which the time code advances. free run: Regardless of the operation mode of this unit, the time code advances all the time that the power is on. rec run: The time code advances only during recording. Note When using this setting, set item 606 to “preset”.
610	DOWNCONVERTER VICT output	<u>on</u> off	Selects whether or not to insert VITC data in the HD-SD converter output. on: VITC data is inserted. off: VITC data is not inserted.
611	VITC POSITION-1 select (NTSC)	12,281 line : <u>16,279 line</u> : 20,283 line	When 29.97PsF/59.94i mode is selected on the VTR, this setting specifies the lines in which the VITC signal is inserted. It can be inserted in any lines from 12,281 to 20,283. Note Items 611 and 612 allow VITC to be inserted in two lines.

Item number	Item	Setting	Function
612	VITC POSITION-2 select (NTSC)	12,281 line : <input type="text" value="16,279 line"/> : 20,283 line	When 29.97PsF/59.94i mode is selected on the VTR, this setting specifies the lines in which the VITC signal is inserted. It can be inserted in any lines from 12,281 to 20,283. Note Items 611 and 612 allow VITC to be inserted in two lines.
613	TC OUTPUT SIGNAL IN REGENE MODE	<input type="text" value="off tape"/> regene through	Specifies the signal output to the TIME CODE OUT connector when the internal time code generator is in a mode for regenerating the playback time code (i.e. during auto edit mode or when item 607 is set to "int-LTC" and item 606 is set to "regene"). off tape: The playback time code signal is output to the TIME CODE OUT connector without regeneration. regene: The playback time code signal is output to the TIME CODE OUT connector after regeneration only when the VTR is in playback mode. through: The time code signal input to the TIME CODE IN connector is output as it is.
614	PHASE CORRECTION	<input type="text" value="off"/> on	Specifies whether the phase correction control of the LTC signal generated by the time code generator is applied or not. off: The phase correction control is not applied. on: The phase correction control is applied.
616	VITC POSITION-1 select (PAL)	9,322 line : <input type="text" value="19,332 line"/> : 22,335 line	When 25PsF/50i mode is selected on the VTR, this setting specifies the lines in which the VITC signal is inserted. It can be inserted in any lines from 9,322 to 22,335. Note Items 616 and 617 allow VITC to be inserted in two lines.
617	VITC POSITION-2 select (PAL)	9,322 line : <input type="text" value="21,334 line"/> : 22,335 line	When 25PsF/50i mode is selected on the VTR, this setting specifies the lines in which the VITC signal is inserted. It can be inserted in any lines from 9,322 to 22,335. Note Items 616 and 617 allow VITC to be inserted in two lines.
618	LTC OUTPUT PHASE select	input auto <input type="text" value="output"/>	Selects the LTC output phase. input: Same phase as input video. auto: When editing, same phase as input video; otherwise (playback, recording, etc.), same phase as output video. output: Same phase as output video.
619	EXT LTC MODE	direct <input type="text" value="regene"/>	Selects the recording mode when the internal time code generator is set to regenerate the input from the TIME CODE IN connector (menu item 607 is set to "ext-LTC", and menu item 606 is set to "regene"). direct: Records the time code input from the TIME CODE IN connector unaltered on the tape. regene: Regenerates the time code input from the TIME CODE IN connector with the internal time code generator.
620	SUPERIMPOSED CHARACTER	<input type="text" value="off"/> on	Specifies whether or not to superimpose time data and operating status information on the signal output from the MONITOR connector of SD SDI OUT, the SD OUT COMPOSITE connector and HD SDI OUTPUT connector. off: No information is superimposed. on: Information is superimposed.

Item number	Item	Setting	Function
622	CHARACTER H-POSITION	0 : <input type="text" value="8"/> : 15	Sets the horizontal position of text information superimposed on the signal output from the MONITOR connector of SD SDI OUT, the SD OUT COMPOSITE connector and HD SDI OUTPUT connector. A setting of 0 displays the information at the left edge of the screen, and the position moves to the right as the setting is increased. There are 16 possible settings, from 0 to 15.
623	CHARACTER V-POSITION	0 : <input type="text" value="22"/> 23	Sets the vertical position of text information superimposed on the signal output from the MONITOR connector of SD SDI OUT, the SD OUT COMPOSITE connector and HD SDI OUTPUT connector. A setting of 0 displays the information at the bottom of the screen, and the position moves up as the setting is increased. There are 24 possible settings, from 0 to 23. Note If two-line display is selected in item 626, sometimes the second line will disappear in the middle of the screen.
624	CHARACTER TYPE	without BG outlined translucent <input type="text" value="with BG"/>	Sets the style of text information such as time codes output from the MONITOR connector of SD SDI OUT, the SD OUT COMPOSITE connector and HD SDI OUTPUT connector. without BG: White characters, with no background. outlined: White characters outlined in black. translucent: White characters on a gray screen background. with BG: White characters on a black background. Note For the SD SDI OUT connector and SD OUT COMPOSITE (MONITOR) connector, the “translucent” setting is automatically changed to “with BG”.
625	CHARACTER SIZE	× 1 <input type="text" value="× 2"/>	Sets the size of text information such as time codes output from the MONITOR of SD SDI OUT, the SD OUT COMPOSITE connector and HD SDI OUTPUT connectors. × 1: Normal size. × 2: Twice normal size.
626	DISPLAY INFORMATION select	time data & status time data & UB time data & CTL time data & VITC <input type="text" value="time data only"/>	When item 620 is set to “on”, this setting specifies the content of text information output from the MONITOR connector of SD SDI OUT, the SD OUT COMPOSITE connector and FORMAT CONV. OUT (OPTION) connector. time data & status: Timer counter display and status information. time data & UB: Timer counter display and user bits. time data & CTL: Timer counter display and CTL. time data & VITC: Timer counter display and VITC. time data only: Timer counter display only.
627	CHAR WARNING DISPLAY at dual line mode	<input type="text" value="off"/> on	When item 626 is set to anything other than “time data only”, this item specifies whether warning messages flash on the second line or not. off: Warning messages do not flash. on: If a warning message exists, it flashes. Notes • Messages that have been cleared are not displayed. For more information about clearing warning messages, see “Clearing warning messages” on page 139. • When there are multiple warning messages, each message flashes twice before it is replaced by the next message.

Item number	Item	Setting	Function
628	REMAIN TIME DISPLAY	<input type="checkbox"/> off 10min <input type="checkbox"/> on	Sets whether to display remaining time on the tape in superimposed character position. off: Do not display remaining time. 10min: Display remaining time when it is 10 minutes or less. on: Always display remaining time. Note The remaining time on the tape is not displayed when no cassette is inserted. The remaining time is not also displayed until the VTR finishes detecting the diameter of the wound tape and estimating the remaining time immediately after the cassette is inserted.
629	CONDITION DISPLAY VIDEO MONITOR	<input type="checkbox"/> enable <input type="checkbox"/> disable	Sets whether or not to display playback signal status in superimposed character position. enable: Displays playback signal status. disable: Does not display playback signal status.
630	TC CONVERT	<input type="checkbox"/> off <input type="checkbox"/> on	Selects whether to convert the playback time code to the operating frequency time code when tapes recorded with different frame rates are used for off-speed playback. off: Does not convert the time code. on: Converts the time code.
631	ORIGINAL TC display	<input type="checkbox"/> off <input type="checkbox"/> on	When item 630 is set to "on," this setting specifies whether the 24-frame time code is displayed or not on the control panel of the VTR before conversion. off: The 24-frame time code is not displayed before conversion. on: The 24-frame time code is displayed before conversion. The type of time code displayed is specified by item 603.
632	JUMPING TC select	<input type="checkbox"/> -3H -2H -1H +1H +2H +3H 0H	Sets the loopback point (JUMPING TC) for converting time code with respect to the reference time code (STARTING TC) for conversion. -3H: The JUMPING TC is set 3 hours before STARTING TC. -2H: The JUMPING TC is set 2 hours before STARTING TC. -1H: The JUMPING TC is set 1 hour before STARTING TC. +1H: The JUMPING TC is set 1 hour after STARTING TC. +2H: The JUMPING TC is set 2 hours after STARTING TC. +3H: The JUMPING TC is set 3 hours after STARTING TC. 0H: The JUMPING TC is set 1 frame before STARTING TC.
633	CHARA ORG TC DISPLAY at dual line mode	<input type="checkbox"/> off <input type="checkbox"/> on	Selects whether to display the time code of the playback tape (original time code) in addition to the converted time code, when time code has been converted and menu item 626 is set to anything other than "time data only". off: The original time code is not displayed. on: The original time code is displayed. The original time code appears in the second line when you set this item set to "on".
634	LAST ERROR LOG NUMBER DISPLAY	<input type="checkbox"/> off <input type="checkbox"/> on blink	Sets whether or not the number of error messages appears in a superimposed character display. off: The number of error messages is not displayed. on: The number of error messages is displayed. blink: The number of error messages is displayed. When a new error is detected, the number flashes.



Items Relating to the Video Control (Nos. 706 to ...)

Item number	Item	Setting	Function
706	FORCED VERTICAL INTERPOLATION OFF	<input type="checkbox"/> auto forced YADD off	Specifies whether or not Y-add operation mode is automatically turned on during DT playback. auto: Y-add operation mode is automatically turned on. forced YADD off: Y-add operation mode is off all the time.
707	ROUNDING (SRW-5500 only)	<input type="checkbox"/> simple adaptive	Selects whether to perform A-ROUNDING™ ¹⁾ processing. simple: Do not perform A-ROUNDING™ processing. 10-bit input signals are simply rounded to 8 bits. adaptive: Perform A-ROUNDING™ processing. 10-bit input signals are adaptively rounded to 8 bits.
708	MASTER LEVEL (HD) preset: 100% (4000H)	0.0% (0H) ⋮ <input type="checkbox"/> 100% (4000H) ⋮ 141.3% (5A70H)	Adjusts the level of the HD video signal output from the HD SDI OUTPUT connectors. Simultaneously adjusts the Y, P _B , and P _R levels.
709	Y LEVEL (HD) preset: 100% (4000H)	0.0% (0H) ⋮ <input type="checkbox"/> 100% (4000H) ⋮ 141.3% (5A70H)	Adjusts the level of the HD video signal output from the HD SDI OUTPUT connectors. Adjusts the Y level of the video signal.
710	P _B LEVEL (HD) preset: 100% (4000H)	0.0% (0H) ⋮ <input type="checkbox"/> 100% (4000H) ⋮ 141.3% (5A70H)	Adjusts the level of the HD video signal output from the HD SDI OUTPUT connectors. Adjusts the P _B level of the video signal.
711	P _R LEVEL (HD) preset: 100% (4000H)	0.0% (0H) ⋮ <input type="checkbox"/> 100% (4000H) ⋮ 141.3% (5A70H)	Adjusts the level of the HD video signal output from the HD SDI OUTPUT connectors. Adjusts the P _R level of the video signal.
712	SETUP LEVEL (HD) preset: 0	-10.0 ⋮ <input type="checkbox"/> 0.0 ⋮ 10.0	Adjusts the level of the HD video signal output from the HD SDI OUTPUT connectors. Adjusts the setup level of the video signal.
713	SYNC PHASE (HD) preset: 0	-128 ⋮ <input type="checkbox"/> 0 ⋮ 127	Controls the H sync phase of the HD video signal output from the HD SDI OUTPUT connectors, according to the menu.
714	FINE (HD) preset: 0	<input type="checkbox"/> 0 ⋮ 1024	Controls the H sync phase of the HD video signal output from the HD SDI OUTPUT connectors, according to the menu.
720	HD OUT BLANK	<input type="checkbox"/> through blank	Turns on and off vertical interval blanking processing of the HD video signals output from the HD SDI OUTPUT connectors and the FORMAT CONV. OUT (OPTION) connectors. through: Do not perform blanking processing. on: Perform blanking processing.
740	VIDEO GAIN (ALL) (HD/UC/SD/DC) preset: 100% (4000H)	0.0% (0H) ⋮ <input type="checkbox"/> 100% (4000H) ⋮ 141.3% (5A70H)	Adjusts the video gain of HD, UC, SD, and DC output. The video level increases with larger setting values of this item.

Item number	Item	Setting	Function
741	CHROMA GAIN (ALL) (HD/UC/SD/DC) preset: 100% (4000H)	0.0% (0H) : 100%(4000H) : 141.3% (5A70H)	Adjusts the chroma gain of HD, UC, SD, and DC output. The chroma level increases with larger setting values of this item.
742	CHROMA PHASE (ALL) (HD/UC/SD/DC) preset: 0	-127 : 0 : 127	Adjusts the chroma phase (HUE) of HD, UC, SD, and DC output.
743	BLACK LEVEL (ALL) (HD/UC/SD/DC) preset: 100% (4000H)	-31.0% (0H) : 0(110H) : 31.0% (220H)	Adjusts the black level of HD, UC, SD, and DC output. Note The range of control possible from the HKDV-900/503 is -8.0% to 8.0%.
755	MASTER LEVEL (D1) preset: 100% (4000H)	0.0% (0H) : 100%(4000H) : 141.3% (5A70H)	Adjusts the level of the D1 video signal output from SD SDI OUT. Simultaneously adjusts the Y, B-Y, and R-Y level.
756	Y LEVEL (D1) preset: 100% (4000H)	0.0% (0H) : 100%(4000H) : 141.3% (5A70H)	Adjusts the level of the D1 video signal output from SD SDI OUT. Adjusts the Y level of the video signal.
757	B-Y LEVEL (D1) preset: 100% (4000H)	0.0% (0H) : 100%(4000H) : 141.3% (5A70H)	Adjusts the level of the D1 video signal output from SD SDI OUT. Adjusts the B-Y level of the video signal.
758	R-Y LEVEL (D1) preset: 100% (4000H)	0.0% (0H) : 100%(4000H) : 141.3% (5A70H)	Adjusts the level of the D1 video signal output from SD SDI OUT. Adjusts the R-Y level of the video signal.
762	SETUP LEVEL (CST) preset: 7.5 IRE	0.0 : 7.5 : 10.0	Adjusts the setup level of the analog composite video signal output from SD OUT COMPOSITE (MONITOR) connector.
763	SYNC PHASE (SD) preset: 0	-128 : 0 : 127	Adjusts the sync phase of the D1 video signal output from SD SDI OUT and analog composite video signal output from SD OUT COMPOSITE (MONITOR) connector.
764	FINE (SD) preset: 0	0 : 1024	Makes fine adjustments to the sync phase of the D1 video signal output from SD SDI OUT and analog composite video signal output from SD OUT COMPOSITE (MONITOR) connector.

Item number	Item	Setting	Function
775	VIDEO OUTPUT DATA	8bit 10bit	Sets the bit size of the output data from the HD-SD converter. 8bit: When connected to an 8-bit system 10bit: When connected to a 10-bit system Notes <ul style="list-style-type: none"> Make sure the bit length matches the destination device. This setting is only active when the HD-SD converter output is set to D1.
776	DOWNCONVERTER INPUT CHECK ENABLE	disable enable	Selects the HD-SD converter mode when the INPUT CHECK button on the control panel is pressed. disable: The INPUT CHECK button is not linked to HD-SD converter output. enable: The INPUT CHECK button is linked to HD-SD converter output. Note The INPUT CHECK button works for all of the HD-SD converter output connectors.
777	DOWNCONVERTER ACTIVE LINE	486 line 485 line 484 line	Sets the number of active lines in the down converter output (NTSC). 486 line: 486 lines (Line 283 is active.) 485 line: 485 lines (Line 283 is blank.) 484 line: 484 lines (Line 21 and line 283 are blank.)
778	BLANK LINE NTSC Sub items all line 12, 275 line 13, 276 line 14, 277 line 15, 278 line 16, 279 line 17, 280 line 18, 281 line 19, 282 line 20, 283 line 21, 284 line	blank through	For Digital Betacam (NTSC) playback, this selects whether or not to apply blanking to the vertical blanking interval of the SD video signal. This selection can be made for each line separately, and the Y/C signals and odd/even fields are blanked simultaneously. blank: Blank line. through: Do not blank line. all line (sub item): When this item is selected, the other items all take the same values.

Item number	Item	Setting	Function
779	BLANK LINE PAL	<input type="checkbox"/> blank	<p>For Digital Betacam (PAL) playback, this selects whether or not to apply blanking to the vertical blanking interval of the SD video signal.</p> <p>This selection can be made for each line separately, and the Y/C signals and odd/even fields are blanked simultaneously.</p> <p>blank: Blank line. through: Do not blank line.</p> <p>all line (sub item): When this item is selected, the other items all take the same values.</p>
	Sub items	through	
	all line		
	9, 322 line		
	10, 323 line		
	11, 324 line		
	12, 325 line		
	13, 326 line		
	14, 327 line		
	15, 328 line		
	16, 329 line		
	17, 330 line		
	18, 331 line		
	19, 332 line		
	20, 333 line		
21, 334 line			
22, 335 line			
790	4:2:2 DUAL STREAM select	<input type="checkbox"/> Stream-A <input type="checkbox"/> Stream-B	<p>When playing back 4:2:2 DUAL format tapes recorded with the SRW-1 or SRW-5800 on the SRW-5000/5500, selects whether to play back Stream-A or Stream-B.</p> <p>Stream-A: Play back the video of Stream-A. Stream-B: Play back the video of Stream-B.</p>
791	DOUBLE SPEED PLAYBACK	<input type="checkbox"/> Normal <input type="checkbox"/> Dual stream	<p>When playing back a double-speed tape (1080/4:2:2/59.94P, 1080/4:2:2/50P) recorded with the SRW-1 or SRW-5800 on the SRW-5000/5500, selects the playback mode.</p> <p>Normal: Play back at normal speed. In this case, the video is played back at 0.5 times normal speed and time code advances at 0.5 times normal speed with respect to playback on the SRW-1 or SRW-5800. It is possible to reassign time code values by time code conversion.</p> <p>Dual stream: Play back at double speed using the Dual stream playback function of this unit.</p> <p>You can select whether to play back frame 1 or frame 2 by using menu item 790 (Stream-A: Frame 1, Stream-B: Frame 2).</p> <p>Note Audio is silent during playback of double-speed tapes.</p>

1) A-ROUNDING™

A method for rounding a 10 bit signal to 8 bits. This process suppresses step noise that occurs when lines which differ slightly from the horizontal are displayed.

A-ROUNDING is a trademark of Sony Corporation.



Items Relating to the Audio Control (Nos. 807 to ...)

Item number	Item	Setting	Function
807	AUDIO MONITOR-L select		Selects the audio channel output from the MONITOR OUTPUT L connector.
	Sub items		
	A-MON CH1	disable <input type="checkbox"/> enable	
	A-MON CH2	<input type="checkbox"/> disable enable	
	A-MON CH3	<input type="checkbox"/> disable enable	
	A-MON CH4	<input type="checkbox"/> disable enable	
	A-MON CH5	<input type="checkbox"/> disable enable	
	A-MON CH6	<input type="checkbox"/> disable enable	
	A-MON CH7	<input type="checkbox"/> disable enable	
	A-MON CH8	<input type="checkbox"/> disable enable	
	A-MON CH9	<input type="checkbox"/> disable enable	
	A-MON CH10	<input type="checkbox"/> disable enable	
	A-MON CH11	<input type="checkbox"/> disable enable	
A-MON CH12	<input type="checkbox"/> disable enable		



Item number	Item	Setting	Function
808	AUDIO MONITOR-R select		Selects the audio channel output from the MONITOR OUTPUT R connector.
	Sub items		
	A-MON CH1	<input type="checkbox"/> disable <input type="checkbox"/> enable	
	A-MON CH2	disable <input type="checkbox"/> enable	
	A-MON CH3	<input type="checkbox"/> disable <input type="checkbox"/> enable	
	A-MON CH4	<input type="checkbox"/> disable <input type="checkbox"/> enable	
	A-MON CH5	<input type="checkbox"/> disable <input type="checkbox"/> enable	
	A-MON CH6	<input type="checkbox"/> disable <input type="checkbox"/> enable	
	A-MON CH7	<input type="checkbox"/> disable <input type="checkbox"/> enable	
	A-MON CH8	<input type="checkbox"/> disable <input type="checkbox"/> enable	
	A-MON CH9	<input type="checkbox"/> disable <input type="checkbox"/> enable	
	A-MON CH10	<input type="checkbox"/> disable <input type="checkbox"/> enable	
	A-MON CH11	<input type="checkbox"/> disable <input type="checkbox"/> enable	
A-MON CH12	<input type="checkbox"/> disable <input type="checkbox"/> enable		
809	DIGITAL JOG SOUND	<input type="checkbox"/> on off	Switches digital jog sound on or off. off: Digital jog sound is off. In this case, the audio from the digital channels is output, even in STILL mode, without speed correction processing on: Digital jog sound is on.
811	DIGITAL AUDIO FADE TIME	5 ms <input type="checkbox"/> 10 ms 15 ms 20 ms 25 ms ^{a)} 50 ms ^{b)} 85 ms 115 ms ^{c)}	Specifies the fade processing time during cross-fading or fading-in/out of digital audio signals. Note Processing for cross fading, fading-in, and fading-out starts after an IN or OUT point. This item specifies rewriting during recording following the OUT point. Rewriting of one field occurs even when the minimum setting (5 ms) is selected. When “cut edit” is selected in item 317 to prevent this from happening, a discontinuity in the audio signal occurs. There is, however, no effect on the recording of the video signal. a) The cross-fade time is 24 ms. b) The actual fade time is 49 ms. c) The actual fade time is 114 ms.
813	AUDIO MONITOR OUTPUT MIXING	add <input type="checkbox"/> rms average	Specifies the type of audio mixing to be conducted on the digital audio signal output to the MONITOR OUTPUT L/R connector. add: Simple addition rms: Multiplied average average: Simple average Note When the CUE channel signal is output to the monitor, signals are mixed by simple addition.



Item number	Item	Setting	Function
814	LEVEL METER SCALE	<input type="text" value="peak 0 dB"/> reference 0 dB	Specifies the mode in which the digital audio level is displayed. peak 0 dB: Displays minus audio levels with the maximum level set at 0 dB. reference 0 dB: Displays plus and minus audio levels with the reference level set at 0 dB. Note The CUE channel level is always displayed with the reference level set at 0 dB.
815	AUDIO OUTPUT PHASE preset: 128	0 : <input type="text" value="128"/> : 255	Sets the output timing for the digital audio playback signal (SDI and AES/EBU only). The 128 setting specifies the reference position. A setting lower than 128 advances the output timing, and a setting higher than 128 delays the output timing. (128 samples, or approx. 2.7 ms, with 1 sample = approx. 20 µs)
816	PITCH CORRECTION	<input type="text" value="off"/> on	Selects whether or not to perform pitch correction during program play and play at a different frequency (23.98 frame ↔ 24 frame, 23.98/24 frame ↔ 25 frame, 29.97 frame ↔ 30 frame). off: Output audio with no pitch correction. on: Output audio with pitch correction.

Item number	Item	Setting	Function
817	PITCH CORRECTION GROUP select		When pitch correction is performed during program play and play at a different frequency (23.98 frame ↔ 24 frame, 23.98/24 frame ↔ 25 frame, 29.97 frame ↔ 30 frame), selects the group relationship between audio channels.
	Sub items		
	PITCH CORRECTION GROUP select CH1	<input type="checkbox"/> Grp-A Grp-B Grp-C Grp-D Grp-E Grp-F OFF	Grp-A: Performs pitch correction according to the mutual relationships between the channels selected for group A.
	PITCH CORRECTION GROUP select CH2	<input type="checkbox"/> Grp-A Grp-B Grp-C Grp-D Grp-E Grp-F OFF	Grp-B: Performs pitch correction according to the mutual relationships between the channels selected for group B.
	PITCH CORRECTION GROUP select CH3	Grp-A <input type="checkbox"/> Grp-B Grp-C Grp-D Grp-E Grp-F OFF	Grp-C: Performs pitch correction according to the mutual relationships between the channels selected for group C.
	PITCH CORRECTION GROUP select CH4	Grp-A <input type="checkbox"/> Grp-B Grp-C Grp-D Grp-E Grp-F OFF	Grp-D: Performs pitch correction according to the mutual relationships between the channels selected for group D.
	PITCH CORRECTION GROUP select CH5	Grp-A Grp-B <input type="checkbox"/> Grp-C Grp-D Grp-E Grp-F OFF	Grp-E: Performs pitch correction according to the mutual relationships between the channels selected for group E.
	PITCH CORRECTION GROUP select CH6	Grp-A Grp-B <input type="checkbox"/> Grp-C Grp-D Grp-E Grp-F OFF	Grp-F: Performs pitch correction according to the mutual relationships between the channels selected for group F.
	PITCH CORRECTION GROUP select CH7	Grp-A Grp-B Grp-C <input type="checkbox"/> Grp-D Grp-E Grp-F OFF	OFF: Does not perform pitch correction for the channels selected for group OFF.
	PITCH CORRECTION GROUP select CH8	Grp-A Grp-B Grp-C <input type="checkbox"/> Grp-D Grp-E Grp-F OFF	
	PITCH CORRECTION GROUP select CH9	Grp-A Grp-B Grp-C Grp-D <input type="checkbox"/> Grp-E Grp-F OFF	
	PITCH CORRECTION GROUP select CH10	Grp-A Grp-B Grp-C Grp-D <input type="checkbox"/> Grp-E Grp-F OFF	
	PITCH CORRECTION GROUP select CH11	Grp-A Grp-B Grp-C Grp-D Grp-E <input type="checkbox"/> Grp-F OFF	
PITCH CORRECTION GROUP select CH12	Grp-A Grp-B Grp-C Grp-D Grp-E <input type="checkbox"/> Grp-F OFF		

Item number	Item	Setting	Function
818	PITCH CORRECTION DETECT MODE select	<u>Mode1</u> Mode2 Mode3 OFF	When pitch correction is performed during program play and play at a different frequency (23.98 frame ↔ 24 frame, 23.98/24 frame ↔ 25 frame, 29.97 frame ↔ 30 frame), selects the pitch correction method for each group. Mode1: Perform pitch correction using zero-cross jump. Mode2: Perform pitch correction using zero-cross jump after low-level detection. Mode3: Perform pitch correction using cross fade. OFF: Do not perform pitch correction.
	Sub items		
	PITCH CORRECTION DETECT MODE select Group-A		
	PITCH CORRECTION DETECT MODE select Group-B		
	PITCH CORRECTION DETECT MODE select Group-C		
	PITCH CORRECTION DETECT MODE select Group-D		
	PITCH CORRECTION DETECT MODE select Group-E		
	PITCH CORRECTION DETECT MODE select Group-F		
830	AUDIO INPUT SELECT	AES/EBU <u>SDI</u>	Selects the input signals for audio channels 1 to 12. This is only valid when item 831 is set to "off". AES/EBU: Selects signal input to DIGITAL I/O (AES/EBU) INPUT connector. SDI: Selects signal input to HD SDI INPUT A connector. A-IN ALL (sub item): Sets the items A-IN CH1 to CH12 to the same value.
	Sub items		
	A-IN ALL		
	A-IN CH1		
	A-IN CH2		
	A-IN CH3		
	A-IN CH4		
	A-IN CH5		
	A-IN CH6		
	A-IN CH7		
	A-IN CH8		
	A-IN CH9		
	A-IN CH10		
	A-IN CH11		
A-IN CH12			

Item number	Item	Setting	Function	
831	NON AUDIO SELECT	AES/EBU SDI	Selects a non-audio input signal. The setting is in units of stereo pairs. When this is set to other than "off", the setting of item 830 is invalid. AES/EBU: Selects signal input to DIGITAL I/O (AES/EBU) INPUT connector as a data input. SDI: Selects signal input to HD SDI INPUT A connector as a data input. off: Treats input as audio. Select the input signal with item 830.	
	Sub items	off		
	CH1/2			
	CH3/4			
	CH5/6			
	CH7/8			
	CH9/10			
	CH11/12			
	HDCAM REC MODE(SRW-5500 only)	BURST DATA MODE CONTINUOS MODE		Selects the format when non-audio data is to be recorded on an HDCAM tape. BURST DATA MODE: Select this to record data compressed in video frame units (Dolby E, etc.). CONTINUOS MODE: Select this to record data compressed without reference to video frames (Dolby Digital (AC-3), etc.).
	832	AUDIO REC LEVEL		FFFF (HEX)
Sub items		:		
A-REC LEVEL CH1		4000 (HEX)		
A-REC LEVEL CH2		:		
A-REC LEVEL CH3		0 (HEX)		
A-REC LEVEL CH4				
A-REC LEVEL CH5				
A-REC LEVEL CH6				
A-REC LEVEL CH7				
A-REC LEVEL CH8				
A-REC LEVEL CH9				
A-REC LEVEL CH10				
A-REC LEVEL CH11				
A-REC LEVEL CH12				
A-REC LEVEL CUE (SRW-5500 only)				

Item number	Item	Setting	Function
833	AUDIO PB LEVEL	FFFF (HEX)	Sets the audio playback level.
	Sub items	⋮	
	A-PB LEVEL CH1	4000 (HEX)	
	A-PB LEVEL CH2	⋮	
	A-PB LEVEL CH3	0 (HEX)	
	A-PB LEVEL CH4		
	A-PB LEVEL CH5		
	A-PB LEVEL CH6		
	A-PB LEVEL CH7		
	A-PB LEVEL CH8		
	A-PB LEVEL CH9		
	A-PB LEVEL CH10		
	A-PB LEVEL CH11		
	A-PB LEVEL CH12		
	A-PB LEVEL CUE		



Item number	Item	Setting	Function
834	DIGITAL AUDIO OUTPUT EXCHANGE		Specifies the audio multiplexed with HD SDI output, and the signal tracks to be output to AES/EBU format audio output channels 1 to 12. Note that SD SDI also follows these settings when SDOUT EXCHNG is set to dis (disable).
	Sub items		
	DIGITAL OUT CH1	TR1 ⋮ TR12	
	DIGITAL OUT CH2	TR1 TR2 ⋮ TR12	
	DIGITAL OUT CH3	TR1 ⋮ TR3 ⋮ TR12	
	DIGITAL OUT CH4	TR1 ⋮ TR4 ⋮ TR12	
	DIGITAL OUT CH5	TR1 ⋮ TR5 ⋮ TR12	
	DIGITAL OUT CH6	TR1 ⋮ TR6 ⋮ TR12	
	DIGITAL OUT CH7	TR1 ⋮ TR7 ⋮ TR12	
	DIGITAL OUT CH8	TR1 ⋮ TR8 ⋮ TR12	
	DIGITAL OUT CH9	TR1 ⋮ TR9 ⋮ TR12	
	DIGITAL OUT CH10	TR1 ⋮ TR10 ⋮ TR12	
DIGITAL OUT CH11	TR1 ⋮ TR11 TR12		

Item number	Item	Setting	Function
	DIGITAL OUT CH12	TR1 ⋮ TR12	
835	ANALOG AUDIO OUTPUT EXCHANGE		Sets the signal track to be superimposed on the analog audio signal output channels 1 to 4.
	Sub items		
	ANALOG OUT CH1	TR1 ⋮ TR12	
	ANALOG OUT CH2	TR1 TR2 ⋮ TR12	
	ANALOG OUT CH3	TR1 ⋮ TR3 ⋮ TR12	
	ANALOG OUT CH4	TR1 ⋮ TR4 ⋮ TR12	





Item number	Item	Setting	Function
836	SD AUDIO OUTPUT EXCHANGE		Makes independent track selections for the audio (channels 1 to 8) to be multiplexed into SD SDI.
	Sub items		
	SDOUT EXCG	<input type="checkbox"/> disable <input type="checkbox"/> enable	disable: Follow the settings of DIGOUT EXCHNG menu CH1 to CH8. enable: Enable the settings of this menu.
	SD OUT CH1	<input type="checkbox"/> TR1 ⋮ TR12	Specifies the signal tracks to assign to audio channels 1 to 8 for multiplexing with SD SDI output.
	SD OUT CH2	TR1 <input type="checkbox"/> TR2 ⋮ TR12	
	SD OUT CH3	TR1 ⋮ <input type="checkbox"/> TR3 ⋮ TR12	
	SD OUT CH4	TR1 ⋮ <input type="checkbox"/> TR4 ⋮ TR12	
	SD OUT CH5	TR1 ⋮ <input type="checkbox"/> TR5 ⋮ TR12	
	SD OUT CH6	TR1 ⋮ <input type="checkbox"/> TR6 ⋮ TR12	
	SD OUT CH7	TR1 ⋮ <input type="checkbox"/> TR7 ⋮ TR12	
SD OUT CH8	TR1 ⋮ <input type="checkbox"/> TR8 ⋮ TR12		
840	AES/EBU INPUT MODE	<input type="checkbox"/> AUTO 48K VLOCK	

Items Relating to Digital Processing (Nos. 902 to ...)

Item number	Item	Setting	Function
902	FREEZE MODE	<input type="checkbox"/> field field1 field2 frame1+2 frame2+1	<p>Specifies the freeze (still-picture) mode and freeze timing during manual freezing (by REMOTE 1-IN(9P) or REMOTE 2 PARALLEL I/O(50P) connector or on the control panel) or automatic freezing.</p> <p>field: Freezes the odd or even field, depending on the timing in freeze mode.</p> <p>field1: Freezes the first (odd) field</p> <p>field2: Freezes the second (even) field</p> <p>frame1+2: Freezes the first and the subsequent second field</p> <p>frame2+1: Freezes the second field and the subsequent first field</p> <p>In the case of freezing in playback modes other than normal playback, the picture is frozen in frame mode only when dynamic tracking is performing a frame operation. The picture is frozen in field mode when dynamic tracking is not operating.</p> <p>The frozen picture does not change even if you change this setting during freeze mode. The change to this setting becomes effective the next time the VTR outputs a still picture.</p> <p>When the stop freeze function is enabled, regardless of the setting of this item, the picture is frozen in frame mode only when dynamic tracking is performing a frame operation, or is frozen in field mode when dynamic tracking is performing a field operation or when it is not operating.</p>
903	FREEZE CONTROL FROM KEY PANEL	<input type="checkbox"/> momentary <input type="checkbox"/> latch	<p>Determines the freeze operation control by button operations.</p> <p>momentary: The picture is frozen only while the button is held down.</p> <p>latch: The picture is frozen when the button is pressed, and remains frozen when the button is released.</p> <p>The frozen picture is cancelled when the button is pressed again.</p> <p>Button operations Freezing in odd or even (first or second) field is specified by item 902. Distinction between the first or second field, follows the distinction in the reference signal.</p>
905	STOP FREEZE CONTROL	<input type="checkbox"/> disable <input type="checkbox"/> enable	Enable or disables the stop freeze function.
910	ACTIVE LINE 1035 CONVERT MODE	<input type="checkbox"/> 1080⇒1035 (CONV) <input type="checkbox"/> 1080⇒1035(CROP)	<p>Selects the conversion mode of the effective scanning line number.</p> <p>1080⇒1035(CONV): Convert the effective scanning line number from 1080 to 1035 preserving the aspect ratio of the image.</p> <p>1080⇒1035(CROP): Convert the effective scanning line number from 1080 to 1035. The four sides of the image are cropped, then it is horizontally expanded.</p>
911	ACTIVE LINE 1080 CONVERT MODE	<input type="checkbox"/> 1080⇒1035 (CONV) <input type="checkbox"/> 1035⇒1080(PANEL)	<p>Selects the conversion mode of the effective scanning line number.</p> <p>1035⇒1080(CONV): Convert the effective scanning line number from 1035 to 1080 preserving the aspect ratio of the image.</p> <p>1035⇒1080(PANEL): Convert the effective scanning line number from 1035 to 1080. The 1035 lines of the image are inserted into the 1035 lines of 1080 lines, then it is horizontally compressed.</p>

Item number	Item	Setting	Function
912	SLOW PROCESS MODE	on <input type="checkbox"/> off	Selects whether or not to activate the function to improve the vertical resolution during slow-motion playback. on: Activate the function to improve the vertical resolution during slow-motion playback. off: Do not activate the function to improve the vertical resolution during slow-motion playback. Note This setting has no effect when the VTR is operated in PsF mode.
913	SOFT BLANKING	<input type="checkbox"/> off on	This process applies a graduation to the first two and last two samples of each horizontal scan line of the video signal, thus making the join in the horizontal blanking interval smoother. on: The first two samples in the video data region are increased gradually, and the last two samples are decreased gradually. off: The values of the entire video data region are displayed unaltered.
921	ASPECT FLAG OFF	<input type="checkbox"/> off on	Adds 16:9/Squeeze identification signal specified by ARIB TR-B17 to down-converted SD output. on: Add 16:9/Squeeze identification signal to down-converted SD output. off: Do not add 16:9/Squeeze identification signal to down-converted SD output.
930	DOWNCONVERTER MODE (DC)	<input type="checkbox"/> EDGE-CROP <input type="checkbox"/> LETTER BOX <input type="checkbox"/> SQUEEZE	Selects the down converter mode. EDGE-CROP: Selects edge crop mode. LETTER BOX: Selects letter box mode. SQUEEZE: Selects squeeze mode.
931	LETTER BOX MODE (DC)	<input type="checkbox"/> 16:9 <input type="checkbox"/> 14:9 <input type="checkbox"/> 13:9	When item 930 is set to "LETTER BOX", this setting specifies the aspect ratio of the HD-SD converter output. 16:9: The aspect ratio of the HD-SD converter output is 16:9. 14:9: The aspect ratio of the HD-SD converter output is 14:9. 13:9: The aspect ratio of the HD-SD converter output is 13:9.
932	H CROP POSITION (DC) preset: 0	-120 : <input type="checkbox"/> 0 : 120	When item 930 is set to "EDGE-CROP," adjusts the down-converted output H crop (horizontal direction of portion cut out in edge crop mode). When item 930 is set to "LETTER BOX" and item 931 is set to "14:9" or "13:9," adjusts the downconverted output in the horizontal direction.
934	CROSS COLOR (DC) preset: 8	0 : <input type="checkbox"/> 8 : 15	Cross color adjustment.
935	DETAIL GAIN (DC) preset: 64	0 : <input type="checkbox"/> 64 (0 dB) : 127	Adjustment of the down converter image enhancer, adjusting the sharpness of enhanced contours.
936	LIMITER (DC) preset: 32	0 : <input type="checkbox"/> 32 : 63	Adjustment of the down converter image enhancer, adjusting the maximum detail level to be added to enhance the previous signal.

Item number	Item	Setting	Function
937	CRISP THRESHOLD (DC) preset: 0	<input type="text" value="0"/> : 15	Adjustment of the down converter image enhancer, and setting an amplitude so that low amplitude signals are not enhanced.
938	LEVEL DEPEND THRESHOLD (DC)		Adjustment of the down converter image enhancer, and setting the brightness range of enhanced contours.
	Sub items		
	DEPEND BLACK (DC)	0 : <input type="text" value="8"/> : 15	
	DEPEND WHITE (DC)	<input type="text" value="0"/> : 15	
939	H DETAIL FREQUENCY select (DC)	2.6 MHz 3.4 MHz <input type="text" value="4.3 MHz"/> 6.7 MHz	Adjustment of the down converter image enhancer, and setting the central frequency for enhanced contours.
940	H/V RATIO (DC) preset: 3	0 : <input type="text" value="3"/> : 7	Adjustment of the down converter image enhancer, and setting the horizontal to vertical ratio for enhanced contours.
941	GAMMA (DC)	<input type="checkbox"/> on off	Activates or deactivates the GAMMA LEVEL setting by the item 941.
942	GAMMA LEVEL (DC) preset: 0	128 : <input type="text" value="0"/> : -128	Adjustment of the down converter image enhancer, and setting the slope of the correction curve. Valid only when the GAMMA LEVEL setting is activated by the menu item 941.
943	CROSS COLOR CRISP (DC) preset: 4	0 <input type="text" value="4"/> 15	Sets the crisp level for down converter output cross color.
944	V-FILTER SELECT	<input type="text" value="mode 0"/> mode 1 mode 2 mode 3	Sets the vertical interpolation filter coefficient for HD-SD converter output.
945	D/C LEGALIZE (DC)	<input type="checkbox"/> OFF ON	For down converter output, selects whether to suppress signals with levels that are lower than the pedestal level. OFF: Do not suppress signals lower than the pedestal level. ON: Suppress signals lower than the pedestal level.
946	D/C COLOR MODE	<input type="text" value="mode 1"/> mode 2	Sets the hue of the down-converter output. mode1: Sets the hue of the conventional SRW-series videocassette recorder. mode2: Sets the hue of the conventional HDW-2000 series/ HDW-F500 videocassette recorder.
950	CONVERTER MODE (UC)	<input type="text" value="EDGE-CROP"/> LETTER BOX SQUEEZE	Selects the mode for up conversion. EDGE-CROP: Select edge crop mode. LETTER BOX: Select letterbox mode. SQUEEZE: Select squeeze mode.
951	H CROP POSITION (UC) preset: 0	-120 : <input type="text" value="0"/> : 120	When "EDGE-CROP" is selected in menu item 950, adjusts the H crop (the frame in the horizontal direction inserted in edge crop mode) in up-conversion output.

Item number	Item	Setting	Function
952	LETTER BOX POSITION (UC) preset: 0	-120 : 0 : 120	When "LETTER BOX" is selected in menu item 950, adjusts the position in the vertical direction of the "letterbox" in up-conversion output.
953	UP CONVERTER PROCESS	FIELD FRAME ADAPTIVE ADAPTIVE-2 ADAPTIVE-3	Selects the original image used for conversion from SD to HD. FIELD: Selects field images. FRAME: Selects frame images. ADAPTIVE (standard mode): For up-conversion, the mode in which the ratio of carrying out conversion from frames or fields is set to the standard value. ADAPTIVE-2 (still image priority mode): For up-conversion, the mode in which the ratio of carrying out conversion from frames is increased. ADAPTIVE-3 (movie priority mode): For up-conversion, the mode in which the ratio of carrying out conversion from fields is increased.
954	DETAIL GAIN (UC) preset: 64	0 : 64 : 127	Adjusts the up converter image enhancer. Adjusts the sharpness of outlines.
955	LIMITTER (UC) preset: 32	0 : 32 : 63	Adjusts the up converter image enhancer. Adjusts the detail maximum level added to emphasize the original signal.
956	CRISP THRESHOLD (UC) preset: 8	0 : 8 : 15	Adjusts the up converter image enhancer. Sets the amplitude value for which small amplitude signals are not emphasized.
957	LEVEL DEPEND THRESHOLD (UC) preset: 8	0 : 8 : 15	Adjusts the up converter image enhancer. Sets the luminance range for edge enhancement.
958	H DETAIL FREQUENCY (UC)	3.2MHz 4.5MHz 5.0MHz 4.0MHz	Adjusts the up converter image enhancer. Sets the central frequency and frequency characteristics for edge enhancement. 3.2MHz: 3.2 MHz \pm 1.1 MHz 4.5MHz: 4.5 MHz \pm 1.4 MHz 5.0MHz: 5.0 MHz \pm 0.7 MHz 4.0MHz: 4.0 MHz \pm 2.0 MHz
959	H/V RATIO (UC) preset: 3	0 : 3 : 7	Adjusts the up converter image enhancer. Sets the vertical to horizontal ratio for edge enhancement.
960	GAMMA LEVEL (UC) preset: 0	128 : 0 : -120	Adjusts the up converter image enhancer. Adjusts the gradient of the correction curve.

Item number	Item	Setting	Function
961	BACKGROUND COLOR (UC)	BACKGROUND COLOR [0] to FFH	Sets the background color for blank areas in up conversion. BACKGROUND COLOR: Sets the color. BG COLOR: Selects TABLE/GRAY/BLUE/BLACK. Y, R-Y, B-Y: Valid only when BG COLOR is set to "TABLE". Adjustable within the range from 0 to FFH.
	Sub items	0 to [80] to FFH	
	BG COLOR	0 to [80] to FFH	
	Y TABLE		
	R-Y TABLE		
	B-Y TABLE		
980	ALPHA CHANNEL LEVEL	white [black]	For 4:4:4 DUAL LINK output, sets the output level of the ALPHA CHANNEL of LINK B output. white: Output white level. black: Output black level.

Stop freeze operation

MODE (Before) \ MODE (After)	STOP	TENSION OFF	STDBY OFF
STILL (dynamic tracking on)	DT picture	DT picture	DT picture
CAPSTAN drive (includes shuttling up to ×10 normal tape speed)	non-DT picture	non-DT picture	non-DT picture
Reel drive (includes shuttling over ×10 normal tape speed)	non-DT picture	non-DT picture	non-DT picture

- A "DT picture" is a frozen picture in noiseless DT playback mode. The picture freezes in frame mode when the dynamic tracking is performing a frame operation. It freezes in field mode when dynamic tracking is not performing a frame operation.
- A "non-DT picture" is a frozen picture in shuttle mode. A block pattern may appear in a non-DT picture, depending on the circumstances.

Items Relating to the Pulldown Control (Nos. A01 to ...)

Item number	Item	Setting	Function
A01	PD TIME CODE DISPLAY	[off] on	Sets whether or not to display the pulldown time code on the time code display area. off: Does not display the pulldown time code. on: Displays the pulldown time code.
A02	PD PRESET FRAME MODE	[24F FRAME MODE] 30F FRAME MODE	Selects the time code to be preset. The A frame of the pulldown sequence can be preset. 24F FRAME MODE: The 24 frames time code is preset. 30F FRAME MODE: The 30 frames time code is preset.
A03	FC SUPERIMPOSED CHARACTER	[off] on	Specifies whether or not to superimpose time data and operating status information on the signal output from the FORMAT CONV. OUT connector. off: No information is superimposed. on: Information is superimposed.
A04	PD DF/NDF SELECT	[drop frame] non-drop frame auto	Selects the running mode for the pulldown time code to be preset. drop frame: Drop frame mode non-drop frame: Non-drop frame mode auto: The unit switches the running mode (DF/NDF) automatically according to the frame frequency of the unit. When the frame frequency is 23.98 Hz, the unit switches to the drop frame mode and switches to the non-drop frame mode when it is 24 Hz.

Item number	Item	Setting	Function
A05	PD EXT SD REF LOCK MODE	<input type="checkbox"/> off lock1 lock2	<p>When the operating frequency is set to 23.98PsF, specifies whether or not the pulldown output signal and down-converted output signal are synchronized with the reference signal by the REF. INPUT 2 connector.</p> <p>off: The pulldown output signal and down-converted output signal are not synchronized with the reference signal by the REF. INPUT. 2 connector.</p> <p>lock1: The pulldown output signal and down-converted output signal are synchronized with the reference signal by the REF. INPUT 2 connector.</p> <p>lock2: The pulldown output signal and down-converted output signal are synchronized with the reference signal by the REF. INPUT 2 connector. When the PB/E-E mode is selected, the amount of delay on the A frame of the pulldown output signal for the A frame of the main video signal is fixed to 2 frames (59.94i).</p> <p>Notes</p> <ul style="list-style-type: none"> • A warning message appears when the HD reference signal and REF. INPUT 2 reference signal are not input or not synchronized. • “lock1” and “lock2” are effective only when the operation mode of this unit is set to 23.98/24PsF. • When editing in 23.98/24PsF mode, with this unit as the recorder and with “lock2” selected, phase synchronization may not be achieved within 5 seconds. Also, edit In points may be out of alignment. In these cases, select “off”.
A06	PD SUPERIMPOSED TIME CODE ID	<input type="checkbox"/> off on	<p>When item 620 and A03 is set to “on”, specifies whether or not the ID (24F/30F) is displayed to the right of superimposed time code.</p> <p>off: No ID is displayed.</p> <p>on: ID (“24F” or “30F”) is displayed.</p> <p>Note</p> <p>The setting of this item is effective only when the operation mode of this unit is set to 23.98PsF or 24PsF.</p>
A07	PD CHARACTER 24F TIME CODE MODE	<input type="checkbox"/> off on	<p>When item 620 and A03 is set to “on”, specifies whether or not the 2 : 3 pulldown 24-frame time data is inserted to the first line instead of 30-frame time data.</p> <p>off: 30-frame time data is displayed.</p> <p>on: 24-frame time data is displayed.</p> <p>Note</p> <p>The setting of this item is effective only when the operation mode of this unit is set to 23.98PsF or 24PsF.</p>
A08	FC REFERENCE select	extrn HD <input type="checkbox"/> extrn SD	<p>Selects the signal to be the reference for the FORMAT CONV. OUT input to the REF. INPUT 2 connector.</p> <p>extrn HD: Use the HD tri-level reference signal input to the REF. INPUT 2 connector as the FORMAT CONV. OUT reference signal.</p> <p>extrn SD: Use the SD reference signal input to the REF. INPUT 2 connector as the FORMAT CONV. OUT reference signal.</p>

Item number	Item	Setting	Function
A10	9-Pin TC sense select	<input type="checkbox"/> LINE FC	<p>Specifies whether or not the time code information of FC output signal is returned when time code sense command is input through the 9-pin connector.</p> <p>LINE: Time code information of main output signal is returned. In pulldown conversion mode, 24-frame/sec time code information is returned.</p> <p>FC: Time code information of FC output signal is returned. In pulldown conversion mode, 30-frame/sec time code is returned.</p> <p>Notes</p> <ul style="list-style-type: none"> • Pulldown output signal and 30-frame/sec time code are synchronized only when this unit is set to PLAY LOCK mode. To synchronize the signals, set item A05 "PD EXT SD REF LOCK MODE" to "lock2". • When editing pulldown output signals with a VTR operating in 30F mode, it may not be possible to achieve sync within 5 seconds. If this occurs, set the preroll time to 7 seconds. <p>Also, normal operation is not possible with devices engaged in player sync.</p>
A20	Black Clip for 444 to 422 Conversion	<input type="checkbox"/> on off	<p>When a 4:4:4 signal is converted to a 4:2:2 signal, this item specifies whether the signal that goes below the black level (040H) is suppressed or not.</p> <p>on: Signals that drop below the black level are suppressed.</p> <p>off: Signals that drop below the black level are not suppressed.</p>

Other Items (Nos. T01 to ...)

Item number	Item	Setting	Function
T01	AUTO REPEAT MODE	<input type="checkbox"/> off on	<p>Selects the repeating operation of PREVIEW in automatic editing.</p> <p>off: PREVIEW in automatic editing is not repeated.</p> <p>on: PREVIEW in automatic editing is repeated. To stop, press the STOP button.</p>
T02	INTERNAL VIDEO SIGNAL GENERATOR (HD)	<input type="checkbox"/> off COLOR BARS(100%) COLOR BARS(75%) MULTI BURST 1 MULTI BURST 2 10 STEPS PULSE & BAR RAMP BLACK	<p>Selects the test signal output by the signal generator built into the VTR.</p> <p>off: The test signal is not generated, and the VTR operates normally.</p> <p>all other settings: The test signal is output from the VTR. At this time it is also possible to record the signal.</p>
T04	INTERNAL AUDIO SIGNAL GENERATOR	<input type="checkbox"/> off silence 1 kHz sine	<p>Selects the operation of audio test signal output.</p> <p>off: The audio test signal is not output.</p> <p>silence: Muted signal.</p> <p>1 kHz sine: 1 kHz (In this case, a 1 kHz -20 dB FS sine wave is supplied to all audio inputs.)</p> <p>Notes</p> <ul style="list-style-type: none"> • When "silence" or "1 kHz sine" is selected, the AUDIO IN and AUDIO MONITOR L/R buttons light up. • When the unit is operated in the 23.98 PsF or 24 PsF mode with "1 kHz sine" selected, the output signal is 960 Hz.

Note

Items T01, T02, and T04 are reset to their factory default settings whenever the power is turned off.

Recording and playback formats**Recording and playback formats:**

Cassette type	Recording/playback mode	System frequency
HDCAM-SR	1920 × 1080/4:2:2	23.98PsF
		24PsF
		25PsF
		29.97PsF
		30PsF
		50i
		59.94i ^{a)}
		60i ^{a)}
	1920 × 1080/4:4:4 (optional HKSR-5003 required)	23.98PsF
		24PsF
		25PsF
		29.97PsF
		30PsF
		50i
		59.94i
1280 × 720/4:2:2	50P	
	59.94P	
HDCAM (playback only on SRW-5000)	1920 × 1080/4:2:2	23.98PsF
		24PsF
		25PsF
		29.97PsF
		30PsF
		50i
		59.94i ^{a)}
		60i ^{a)}

Recording formats:

Cassette type	Playback mode	System frequency
Digital Betacam (optional HKSR-5002 required)	625/4:2:2	50i
	525/4:2:2	59.94i

a) When the number of valid input signal lines is 1035, the system detects this and automatically selects 1035 recording mode.

Recording tape format conversion outputs

System frequency Recording tape format		1080							720		
		23.98PsF	24PsF	25PsF	29.97PsF	30PsF	50i	59.94i	60i	50P ^{c)}	59.94P ^{c)}
1080	23.98PsF	○	●	△	▲	▲	△ ^{a)}	▲ ^{a)}	▲ ^{a)}		
	24PsF	●	○	△	▲	▲	△ ^{a)}	▲ ^{a)}	▲ ^{a)}		
	25PsF	△	△	○	▲	▲	○ ^{a)}	▲ ^{a)}	▲ ^{a)}		
	29.97PsF	▲	▲	▲	○	●	▲ ^{a)}	○ ^{a)}	● ^{a)}		
	30PsF	▲	▲	▲	●	○	▲ ^{a)}	● ^{a)}	○ ^{a)}		
	50i	△ ^{b)}	△ ^{b)}	○ ^{b)}	▲ ^{b)}	▲	○	▲	▲		
	59.94i	▲ ^{b)}	▲ ^{b)}	▲ ^{b)}	○ ^{b)}	●	▲	○	●		
	60i	▲ ^{b)}	▲ ^{b)}	▲ ^{b)}	● ^{b)}	○	▲	●	○		
720	50P ^{c)}									○	
	59.94P ^{c)}										○

○: Normal playback of video, audio, and time code possible.

●: 0.1% off-speed playback of video, audio, and time code possible.

△: Off-speed playback of video and audio possible. Time code playback and time code conversion possible (differs depending on menu settings).

▲: HDCAM-SR: Off-speed playback of video and audio possible. Time code conversion possible (differs depending on menu settings. *For details, see menu item 630 on page 160.*)

HDCAM: Off-speed playback of video possible. Audio is muted, and time code conversion possible (differs depending on menu settings. *For details, see menu item 630 on page 160.*)

a) Output as PsF to HD SDI OUTPUT connectors.

b) Output as Interlaced to HD SDI OUTPUT connectors.

c) 720/59.94P or 720/50P is enabled only for HDCAM-SR.

Note

Tapes with different sampling methods cannot be played back (4:4:4/4:2:2).



Recording and playback tape formats and conversion output

Cassette type	Recording/playback mode	HD SDI output	SD output	FC output ^{a)}
		System frequency	System frequency	System frequency
HDCAM or HDCAM-SR	1080/4:2:2	23.98PsF	525/59.94i ^{a)}	1080/4:2:2/59.94i
				720/4:2:2/59.94P
				1080/4:4:4/23.98PsF
		24PsF		1080/4:2:2/60i
				1080/4:4:4/24PsF
		25PsF	625/50i	720/4:2:2/50P
				1080/4:4:4/25PsF
		29.97PsF	525/59.94i	720/4:2:2/59.94P
				1080/4:4:4/29.97PsF
		30PsF		1080/4:4:4/30PsF
		50i	625/50i	720/4:2:2/50P
	1080/4:4:4/50i			
	59.94i	525/59.94i	720/4:2:2/59.94P	
1080/4:4:4/59.94i				
60i		1080/4:4:4/60i		
1035/4:2:2	59.94i	525/59.94i		
		60i		
HDCAM-SR	720/4:2:2	50P	625/50i	1080/4:2:2/50i
		59.94P	525/59.94i	1080/4:2:2/59.94i
Digital Betacam ^{b)}	1080/4:2:2 ^{d)}	50i	625/50i	720/4:2:2/50P
	720/4:2:2 ^{e)}	50P	625/50i	1080/4:2:2/50i
	1080/4:2:2 ^{d)}	59.94i	525/59.94i	720/4:2:2/59.94P
	720/4:2:2 ^{e)}	59.94P	525/59.94i	1080/4:2:2/59.94i
HDCAM-SR	1080/4:4:4 ^{c)}	23.98PsF	525/59.94i ^{a)}	1080/4:2:2/23.98PsF
				1080/4:2:2/59.94i
				720/4:2:2/59.94P
		24PsF		1080/4:2:2/24PsF
				1080/4:2:2/60i
		25PsF	625/50i ^{a)}	1080/4:2:2/25PsF
				720/4:2:2/50P
		29.97PsF	525/59.94i ^{a)}	1080/4:2:2/29.97PsF
		30PsF		1080/4:2:2/30PsF
		50i	625/50i ^{a)}	1080/4:2:2/50i
720/4:2:2/50P				
59.94i	525/59.94i ^{a)}	1080/4:2:2/59.94i		
		720/4:2:2/59.94P		
60i		1080/4:2:2/60i		

a) Optional HKSR-5001 required.

b) Optional HKSR-5002 required.

c) Optional HKSR-5003 required.

d) When the system setting is 1080, only playback is possible.

e) When the system setting is 720, only playback is possible.

Relation between HKDV-900/503 setting items and setup menu items of this unit

In the cells of the “Setup menu items of this unit” column, the brackets indicate available outputs.

HKDV-900/503 setting items	Setup menu items of this unit
HD Master	708: MASTER LEVEL (HD) [HD/UC]
HD Y	709: Y LEVEL (HD) [HD/UC]
HD P _B	710: P _B LEVEL (HD) [HD/UC]
HD P _R	711: P _R LEVEL (HD) [HD/UC]
HD Setup	712: SETUP LEVEL (HD) [HD/UC]
HD Sync Phase	713: SYNC PHASE (HD) [HD/UC]
HD Fine	714: FINE (HD) [HD/UC]
D1 Master	755: MASTER LEVEL (D1) [DC/SD] ^{b)}
D1 Y	756: Y LEVEL (D1) [DC/SD] ^{b)}
D1 B–Y	757: B–Y LEVEL (D1) [DC/SD] ^{b)}
D1 R–Y	758: R–Y LEVEL (D1) [DC/SD] ^{b)}
D2 VIDEO	740: VIDEO GAIN (ALL) [HD/UC/SD/DC] ^{e)}
D2 CHROMA	741: CHROMA GAIN (ALL) [HD/UC/SD/DC] ^{e)}
D2 HUE	742: CHROMA PHASE (ALL) [HD/UC/SD/DC] ^{e)}
D2 SETUP	762: SETUP LEVEL (CST) [DC/SD] ^{c)}
	743: BLACK LEVEL (ALL) [HD/UC/SD/DC] ^{e), f)}
SD Sync Phase	763: SYNC PHASE (SD) [DC/SD]
SD Fine	764: FINE (SD) [DC/SD]
CROSS COLOR	934: CROSS COLOR (DC) [DC]
H CROP POSITION	932: H CROP POSITION (DC) [DC] / 951: H CROP POSITION (UC) [UC/FC] ^{a)} / 952: LETTER BOX POSITION (UC) [UC/FC] ^{d)}
DETAIL GAIN	935: DETAIL GAIN (DC) [DC] / 954: DETAIL GAIN (UC) [UC/FC] ^{a)}
LIMITER	936: LIMITTER (DC) [DC] / 955: LIMITTER (UC) [UC/FC] ^{a)}
CRISP	937: CRISP THRESHOLD (DC) [DC] / 956: CRISP THRESHOLD (UC) [UC/FC] ^{a)}
DEPEND	938: LEVEL DEPEND THRESHOLD (DC) [DC] / 957: LEVEL DEPEND THRESHOLD (UC) [UC/FC] ^{a)}
FREQUENCY	939: H DETAIL FREQUENCY select (DC) [DC] / 958: H DETAIL FREQUENCY (UC) [UC/FC] ^{a)}
H/V RATIO	940: H/V RATIO (DC) [DC] / 959: H/V RATIO (UC) [UC/FC] ^{a)}
GAMMA	942: GAMMA LEVEL (DC) [DC] / 960: GAMMA LEVEL (UC) [UC/FC] ^{a)}
CROP	930: DOWNCONVERTER MODE (DC) [DC] / 950: CONVERTER MODE (UC) [UC/FC] ^{a)}
LETTER BOX	930: DOWNCONVERTER MODE (DC) [DC] / 950: CONVERTER MODE (UC) [UC/FC] ^{a)}
SQUEEZE	930: DOWNCONVERTER MODE (DC) [DC] / 950: CONVERTER MODE (UC) [UC/FC] ^{a)}

a) Select whether to set DC or UC with sub item “IMAGE ENHANCER” of menu item 204 (VIDEO REMOTE CONTROL SELECT). When both are selected (menu item 204 is U&D), both of the corresponding menu settings are made, but this unit's answer values and unity values are the DC values.

b) With the exception of composite output.

c) Use sub item “D2 SETUP” of menu item 204 “VIDEO REMOTE CONTROL SELECT” to determine whether to control menu item 762 “SETUP LEVEL (CST)” or 743 “BLACK LEVEL (ALL)”.

d) When operating on the UC side, the setting of menu item 950 “CONVERTER MODE (UC)” automatically determines whether menu

item 951 “H CROP POSITION (UC)” or menu item 952 “LETTER BOX POSITION (UC)” is used.

e) Supported by Sys1/Sys2/CP Ver. 2.70 or higher.

f) Supported by Sys1/Sys2/CP Ver. 3.00 or higher.

HD: HD SDI output during HDCAM-SR/HDCAM playback

DC: Down-converted SD (SD SDI/COMPOSITE) output during HDCAM-SR/HDCAM format playback

SD: SD (D1 (SD SDI/COMPOSITE) output during Digital Betacam format playback

UC: Upconverted HD SDI output during Digital Betacam format playback

MPEG-4 Visual Patent Portfolio License

THIS PRODUCT IS LICENSED UNDER THE MPEG-4 VISUAL PATENT PORTFOLIO LICENSE FOR THE PERSONAL AND NON-COMMERCIAL USE OF A CONSUMER FOR

- (i) ENCODING VIDEO IN COMPLIANCE WITH THE MPEG-4 VISUAL STANDARD (“MPEG-4 VIDEO”) AND/OR
- (ii) DECODING MPEG-4 VIDEO THAT WAS ENCODED BY A CONSUMER ENGAGED IN A PERSONAL AND NON-COMMERCIAL ACTIVITY AND/OR WAS OBTAINED FROM A VIDEO PROVIDER LICENSED BY MPEG LA TO PROVIDE MPEG-4 VIDEO.

NO LICENSE IS GRANTED OR SHALL BE IMPLIED FOR ANY OTHER USE. ADDITIONAL INFORMATION INCLUDING THAT RELATING TO PROMOTIONAL, INTERNAL AND COMMERCIAL USES AND LICENSING MAY BE OBTAINED FROM MPEG LA, LLC. SEE [HTTP://WWW.MPEGLA.COM](http://www.mpegla.com)

MPEG LA is offering licenses for (i) manufacturing/sales of any storage media storing MPEG-4 Visual video information (ii) distribution/broadcasting of MPEG-4 Visual video information in any manner (such as online video distribution service, internet broadcasting, TV broadcasting). Other usage of this product may be required to obtain license from MPEG LA. Please contact MPEG LA for any further information. MPEG LA, L.L.C., 250 STEELE STREET, SUITE 300, DENVER, COLORADO 80206, <http://www.mpegla.com>

Index

A

- AC IN connector 29
- Adjusting
 - audio playback level 108
 - output video signal 89
- Advanced Automatic Editing 127
- ALT button 19
- Assemble mode 116
- AUDIO IN/OUT buttons 21
- AUDIO Menu 92
- AUDIO OUTPUT CH1 to CH4
 - connectors 26
- AUTO button 20
- Automatic edit modes 116
- Automatic editing 116
 - animation editing 128
 - confirming edit points 121
 - cuing up and prerolling 122
 - DMC editing 127
 - Modifying edit points 123
 - Non-audio data 121
 - Overview 116
 - Preread editing 128
 - Previewing 122
 - Selecting the edit mode 118
 - Setting edit points 118
 - Setting switches and menus 117
 - Steps 116

B

- Basic Automatic Editing 116

C

- Capstan override playback 112
- Cassettes
 - handling cassettes 35
 - inserting and ejecting cassettes 35
 - preventing accidental erasure 36
 - recommended cassettes 35
- Changing
 - menu settings 38
 - preroll time 122
- CHANNEL CONDITION indicators 17
- CLR button 20
- Color display 19
- Confirming edit points 121
- Connecting external equipment 30
 - cascade connection 32
 - making HD digital connections 30

- making NTSC/PAL Digital Connections 31
- Connector panel 25
 - ANALOG I/O section 26
 - DIGITAL I/O section 28
 - power supply 29
 - remote input/output section 29
- Control panel 16
 - lower control panel (Display section) 21
 - lower control panel (Editing control section) 20
 - lower control panel (Menu control section) 18
 - lower control panel (Search control section) 23
 - lower control panel (System Set-Up Panel) 24
 - lower control panel (Tape transport control section) 21
 - upper control panel 17
- CONTROL PANEL connector 24
- CTL timer 60
- CUE IN connector 27
- CUE menu 69
- CUE OUT connector 27
- Cue point
 - erasing 72
 - prerolling 72
 - registering 70
- Cursor buttons 20
- Cut editing 152

D

- Deleting edit points 123
- DF (drop frame) mode 156
- DIAG button 19
- DIGITAL I/O INPUT connectors 28
- DIGITAL I/O OUTPUT connectors 28
- DISPLAY button 19
- Display section 21
- Displaying the duration 121
- DMC editing 127
 - overview 127
 - performing 128
 - setting edit points and playback speed 127
- DMC playback 53
 - overview 112

E

- Editing control section 20
- Editing point
 - confirming 121

- deleting 123
- modifying 123
- moving 123
- setting 118, 120
- Editing precautions 116
- Effective scanning line number 175
- EJECT button 17
- Ejecting the cassette 36
- Emphasis 140
- ENTRY button 20
- ERROR indicator 17
- Error Log Menu
 - adjusting the clock 139
 - clearing warning messages 139
- Error log menu 138
- Error Messages 135
- ETHERNET connector 29
- EXTEND mode 153

F

- Fade-in/out 121, 152
- FC OUT B connectors 28
- FORMAT CONV. OUT (OPTION)
 - connectors 28
- Format indicators 17
- FULL/FINE button 19
- Function buttons 19

H

- HD REF. OUT connectors 27
- HD SDI INPUT A/B connectors 28
- HD SDI OUTPUT connectors 28
- HD-SD conversion mode
 - edge crop mode 109
 - letter box mode 109
 - squeeze mode 109
- Head cleaning 131
- HOME menu 51

I

- IN/OUT buttons 21
- Information display 21
- INPUT CHECK button 20
- Insert mode 116

J

- JOG button 23
- Jog mode playback 110

L

- Lower control panel 18

M

- Maintenance 131

Manual editing 130
 Memory label 12, 13, 74
 “Memory Stick”
 adding titles 47
 data compatibility 48
 formatting 42
 operations 42
 recalling 45
 storing 43
 storing cue point lists 44
 Menu
 changing a CUE point into an edit
 point 73
 configuration 38
 control section 18
 list 142
 PANEL SETUP menu 101
 PF1 menu 38
 PF2 menu 38
 registering items to the VTR
 SETUP menu 39
 selection buttons 18
 Moisture condensation 131
 MONITOR L buttons 18
 MONITOR OUTPUT L/R connectors
 26
 MONITOR R buttons 18
 Monitoring video and audio signals
 being recorded 106
 MULTI CONTROL knob 18

N

NDF (Non-drop frame) mode 156
 Normal-speed playback 110
 Numeric buttons and +/- buttons 20

O

Overview
 automatic editing 116
 DMC editing 127
 DMC playback 112

P

PAGE mode 153
 PANEL SETUP menu 101
 Pausing the current time 61
 PB LEVEL button 19
 PCM CIA card slot 24
 PF1 menu 13, 148
 PF2 menu 13, 148
 PHONES jack 18
 PHONES level control 18
 Pitch correction function 12
 PLAY button 21
 Playback 110
 capstan override playback 112

DMC playback 112
 jog mode playback 110
 non-audio data 113
 normal-speed playback 110
 shuttle mode playback 111
 variable mode playback 111
 variable speed playback 110
 PLAYER/RECORDER buttons 20
 POWER switch 17
 Preparing for playback 108
 adjusting the audio playback level
 108
 improve the vertical resolution
 176
 selecting the HD-SD conversion
 mode 109
 selects the conversion mode of the
 effective scanning line
 number 175
 setting switches and menus 108
 Preparing for recording 103
 adjusting the recording level 105
 selecting audio signals 104
 setting switches and menus 103
 Preread editing 128
 PREREAD indicator 23
 PREROLL button 21
 Preroll time setting 53
 PREVIEW/REVIEW button 21
 Program play function 12
 Pulldown output 180
 Pulldown time code
 displaying 65
 presetting 62

R

RCL button 20
 REC INHIBIT indicator 23
 REC LEVEL button 20
 REC/EDIT button 21
 Recording 107
 inhibit mode 52
 REF SYNC indicators 22
 REF. INPUT 1 connectors 26
 REF. INPUT 2 connectors 26
 Reference signal connections 34
 REMOTE 1-I/O connector 29
 REMOTE 1-IN connector 29
 REMOTE 2 PARALLEL I/O
 connector 29
 REMOTE buttons 17
 RS232C connector 29

S

SD OUT COMPOSITE (MONITOR)
 connector 27

SD OUT SYNC connector 26
 SD SDI OUT connectors 28
 Search control section 23
 Search dial 23
 Selecting
 audio input signals 104
 audio signals to be monitored 104
 Conversion mode of the effective
 scanning line number
 175
 CTL display mode 62
 DMC playback 53
 edit mode 52
 HD-SD conversion mode 109
 multi-cue mode 70
 non-audio data as the audio input
 signal 105
 output signals 52
 reference signal 33
 remote operation mode 98
 time code and the user bits to be
 recorded 59
 SERVO indicator 23
 SET button 20
 SET UP menu 98
 SFT button 20
 SHUTTLE button 23
 Shuttle mode playback 111
 Slow-motion playback
 improve the vertical resolution
 176
 Specifications 132
 Split editing 119
 STANDBY button 21
 STOP button 21
 Superimposition of character
 information 65
 System set-up panel 24

T

Tape transport control section 21
 TC menu 57
 TELE FILE menu 73
 Tele-File 12
 Time code
 presetting for conversion from
 Frame time code 63
 running mode 61
 setting 61
 time code generator (TCG
 SOURCE/MODE) 61
 TIME CODE IN connector 27
 TIME CODE OUT connector 27
 Time code reader (TCR) 61
 Time data
 resetting 60
 selecting the time data display 58

setting 58

U

Upper control panel 17

USB connector 29

User bits setting 60

Using a “Memory Stick” 36

Using the CD-ROM manual 15

V

VAR button 23

Variable speed playback 110

VIDEO CONTROL connector 29

VIDEO Menu 88

VTR memory banks 40

adding titles 47

recalling 41

storing 40

VTR SETUP menu 99

items related to digital processing
175

items related to editing 150

items related to operation panels
146

items related to prerolling 153

items related to recording
protection 154

items related to remote interface
149

items related to the audio control
165

items related to the pulldown
control 179

items related to the time code 156

items related to the video control
161

items related to VTR operations
142

Other items 181

W

WARNING indicator 17

Warning messages 136



Index

The material contained in this manual consists of information that is the property of Sony Corporation and is intended solely for use by the purchasers of the equipment described in this manual.

Sony Corporation expressly prohibits the duplication of any portion of this manual or the use thereof for any purpose other than the operation or maintenance of the equipment described in this manual without the express written permission of Sony Corporation.

Trademarks

- Intel and Pentium are registered trademarks of Intel Corporation or its subsidiaries in the United States and other countries.
- Microsoft and Windows are registered trademarks of Microsoft Corporation in the United States and/or other countries.
- Adobe, Acrobat, and Adobe Reader are trademarks of Adobe Systems Incorporated in the United States and/or other countries.

For Customer in China

根据中华人民共和国信息产业部第39号令《电子信息产品污染控制管理办法》及标准中要求的“有毒有害物质或元素名称及含量”等信息，本产品相关信息请参考以下链接：

<http://pro.sony.com.cn>

制造商：索尼公司

地址：日本国东京都港区港南1-7-1

原产地：日本

总经销商：索尼（中国）有限公司

进口商地址：北京市朝阳区东三环北路霞光里18号佳程大厦A座25层

出版日期：2008年10月

Sony Corporation

SRW-5000/5500
(SY)
4-118-418-02 (1)



<http://www.sony.net/>

Printed on recycled paper.

Printed in Japan
2008.10.13
© 2003