

**Panasonic**

# The AG-UX180, UX90 Book



**For AG-UX90**

**System frequency and output format (frame rate) differ by available country/region. This document explains the model supports 59.94Hz system.**

# Table of contents

1. Image sensor & record formats .....	4
1-1. Image size comparison between 4K/UHD and HD formats.....	5
1-2. Key features.....	6
1-3. Record modes.....	7
1-4. Recording in different codecs with 2 memory cards.....	8
2. Preparation before Shooting.....	9
2-1. Major IN/OUT connectors (AG-UX180).....	10
2-1. Major IN/OUT connectors (AG-UX90).....	11
2-2. Record mode settings .....	12
2-3. Audio input settings.....	12
2-4. Record modes and required speed class of SD memory cards .....	13
2-5. Mounting to Tripod .....	13
3. MENU settings .....	14
SCENE FILE .....	16
SYSTEM MODE.....	18
USER SW .....	20
SW SETUP .....	23
AUTO SW .....	26
RECORD SETUP.....	27
AUDIO SETUP.....	28
OUTPUT SETUP.....	29
DISP SETUP .....	30
OTHER FUNCTIONS.....	32
NETWORK SETUP.....	33
MAINTENANCE .....	33
4. Understanding advanced features.....	34
4-1. Monitoring 4K & UHD image .....	35
4-2. Understanding Focus assist features .....	36
4-3. Understanding Dual memory card slots .....	37
4-4. Synchronizing timecode for multi-cam operation .....	38
4-5. Understanding user customizable image stabilizer .....	39
4-6. Understanding user customizable auto focus .....	40
4-7. Understanding Focus transition feature .....	41
4-8. Understanding Remote operation via AG ROP iPad app.....	42

5. Understanding scene file operations .....	44
5-1. SCENE FILE presets .....	45
5-2. Factory default settings .....	45
5-3. Expressing the texture of objects (detail enhancement).....	46
5-4. Basic settings for Detail.....	47
Detail control .....	47
5-5. Expressing the gradation of a picture (Knee, Gamma) .....	50
Gamma settings.....	52
Black gamma control.....	58
6.After recording.....	59
6-1. Connecting to PC/Mac .....	60
6-2. File structure of SD memory card.....	60
6-3. Folder name structure for MOV/MP4 folders.....	61
7. Appendix.....	62
7-1. Recording time in each video setting .....	63
7-2. Output signal formats .....	66
1. AG-UX180 System frequency: 59.94Hz .....	66
2. AG-UX180 System frequency: 50.00Hz .....	67
3. AG-UX90 System frequency: 59.94Hz .....	68
7-3. Genuine accessories.....	69
Revision history.....	71

# 1. Image sensor & record formats



# 1. Image sensor & record formats

## 1-1. Image size comparison between 4K/UHD and HD formats

The UHD (3840x2160) image is four times sharper than an FHD 1080p image (nine times that of 720p). And the 4096x2160 resolution (referred to as “4K” on AG-UX180), which is often used for cinema shooting, has a slightly wider image aspect ratio of 17:9. In comparison to a UHD image, this is an extra 256 pixels in the horizontal direction.

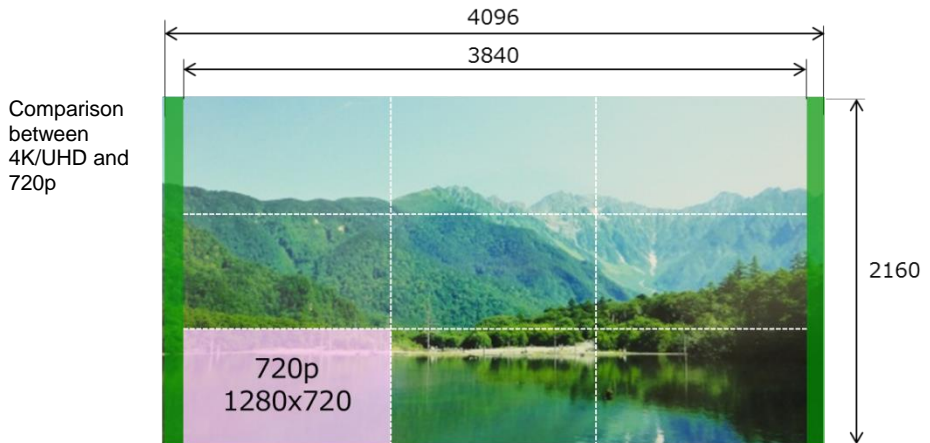

Record format	Resolution	Aspect ratio
4K	4096 x 2160	17:9
UHD (Ultra HD)	3840 x 2160	16:9
FHD (Full HD)	1920 x 1080	16:9

# 1. Image sensor & record formats

## 1-2. Key features

	<b>AG-UX180</b>	<b>AG-UX90</b> (for 59.94Hz region)
Optical zoom (i.Zoom)	20x (30x)	15x (25x)
4K(4096x2160) record	24p	-
UHD(3840x2160) record	59.94p, 50p, 29.97p, 25p, 23.98p	23.98p, 29.97p
FHD(1920x1080) record	59.94p, 50p, 29.97p, 25p, 23.98p, 59.94i, 50i	59.94p, 29.97p, 23.98p, 59.94i
Variable Frame rate *1 recording	50.00Hz: 2-50fps + 100fps 59.94Hz: 2-60fps + 120fps	2-60fps
Simul record (P.37)	✓	✓
Relay record (P.37) *2	✓	✓
Dual codec record (P.37)	✓	-
Background record (P.37)	✓	-
Infrared (IR) record	✓	-
TC Synchronization (P.38)	✓	-
SDI OUT	✓ (Support 3G-SDI)	-
HDMI OUT	✓ (Support UHD 59.94p & 50p)	✓ (Support UHD 29.97p)

\*1: Variable Frame Rate recording mode is available in FHD mode only.

\*2: Memory cards are exchangeable without stopping recording.

# 1. Image sensor & record formats

## 1-3. Record modes

A 4K, Ultra High Definition (UHD), and FHD images in MP4/MOV formats can be selected. And also possible to select lower bitrate HD/SD images in AVCHD format.

### For AG-UX180

	Resolution	Frame rate	Bit rate	Compression	Audio
4K/UHD	4096x2160	24.00p	100Mbps	Long GOP	LPCM
	3840x2160	59.94p, 50p	150Mbps		
		29.97p, 25p, 23.98p	100Mbps		
FHD	1920x1080	59.94p, 50p	200Mbps	ALL-Intra	LPCM
		29.97p, 25p, 23.98p			
		59.94p, 50p	100/50Mbps	Long GOP	
		29.97p, 25p, 23.98p			
		59.94i, 50i			
AVCHD	1920x1080	59.94p, 50p	25Mbps	Long GOP	Dolby Digital
		59.94i, 50i	21/17Mbps		
		23.98p	21Mbps		
	1440x1080	59.94i, 50i	5Mbps		
	1280x720	59.94p, 50p	8Mbps		
	720x480	59.94i	9Mbps		
720x576	50i				

### For AG-UX90

	Resolution	Frame rate	Bit rate	Compression	Audio
UHD	3840x2160	29.97p, 23.98p	100Mbps	Long GOP	LPCM
FHD	1920x1080	59.94p	50Mbps	Long GOP	LPCM
		29.97p, 23.98p			
		59.94i			
AVCHD	1920x1080	59.94p	25Mbps	Long GOP	Dolby Digital
		59.94i	21/17Mbps		
		23.98p	21Mbps		
	1440x1080	59.94i	5Mbps		
	1280x720	59.94p	8Mbps		
720x480	59.94i	9Mbps			

# 1. Image sensor & record formats

## 1-4. Recording in different codecs with 2 memory cards

UX180

UX90

Simultaneous recording with two different codecs is possible. It allows users to record high quality UHD image for main recording while capturing light-weight FHD images for scenario checks etc.

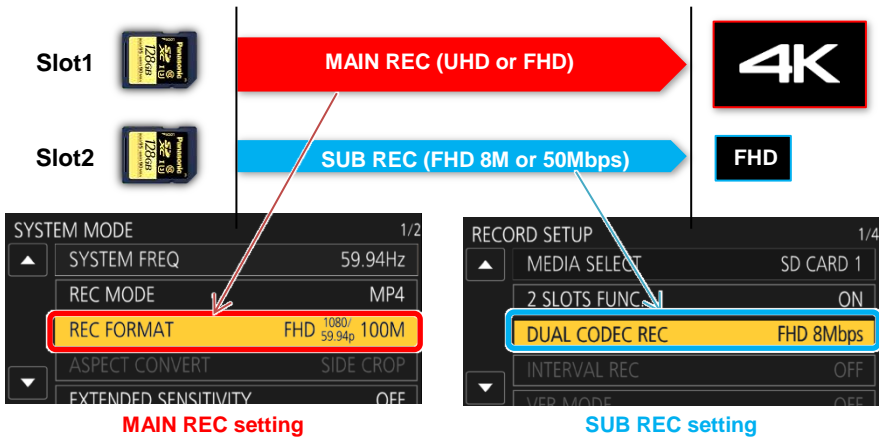

### MAIN + SUB record combinations

MAIN REC		+	SUB REC (50Mbps)		OR	SUB REC (8Mbps)	
Format	Bitrate (bps)		Format	Codec		Format	Codec
UHD@29.97p	100M	+	FHD@29.97p	MP4, MOV	OR	FHD@29.97p	MOV
UHD@25p	100M	+	FHD@25p	MP4, MOV	OR	FHD@25p	MOV
UHD@23.98p	100M	+	FHD@23.98p	MP4, MOV	OR	FHD@23.98p	MOV
FHD@59.94p	200M			+		FHD@59.94p	MOV
FHD@59.94p	100M			+		FHD@59.94p	MOV
FHD@50p	200M			+		FHD@50p	MOV
FHD@50p	100M			+		FHD@50p	MOV
FHD@29.97p	200M			+		FHD@29.97p	MOV
FHD@25p	200M			+		FHD@25p	MOV
FHD@23.98p	200M			+		FHD@23.98p	MOV

NOTE: DUAL CODEC feature does not function under the following conditions.

- Variable frame rate record mode (VFR) is ON.
- Interval recording mode is ON.
- Super slow mode is ON.



## 2. Preparation before Shooting



# 2. Preparation before shooting

## 2-1. Major IN/OUT connectors (AG-UX180)

UX180 UX90

Image resolution of HDMI, SDI and AV OUT signals vary and will depend on the system settings. See 7-2. Output signal (P.66) for the details.

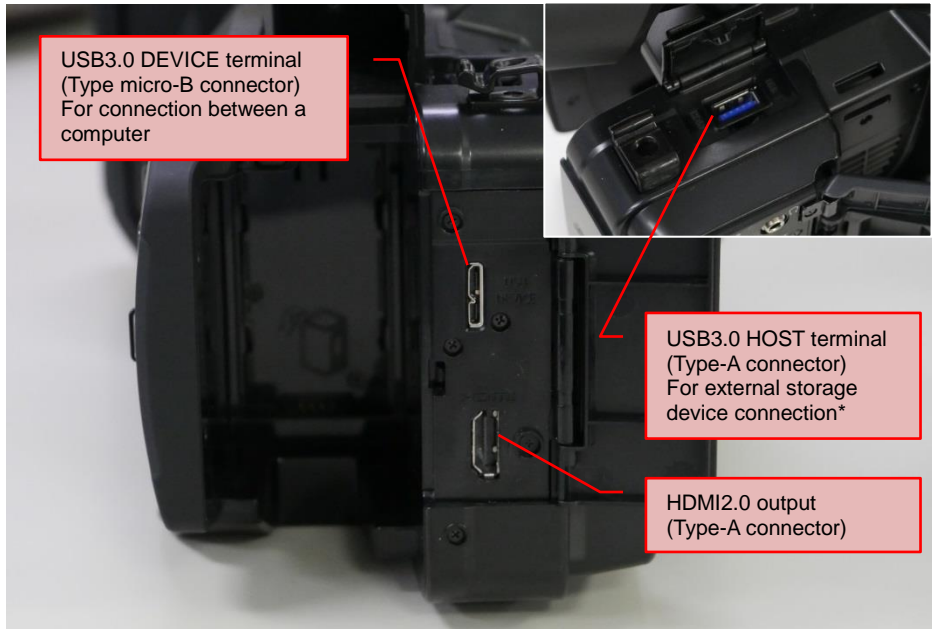
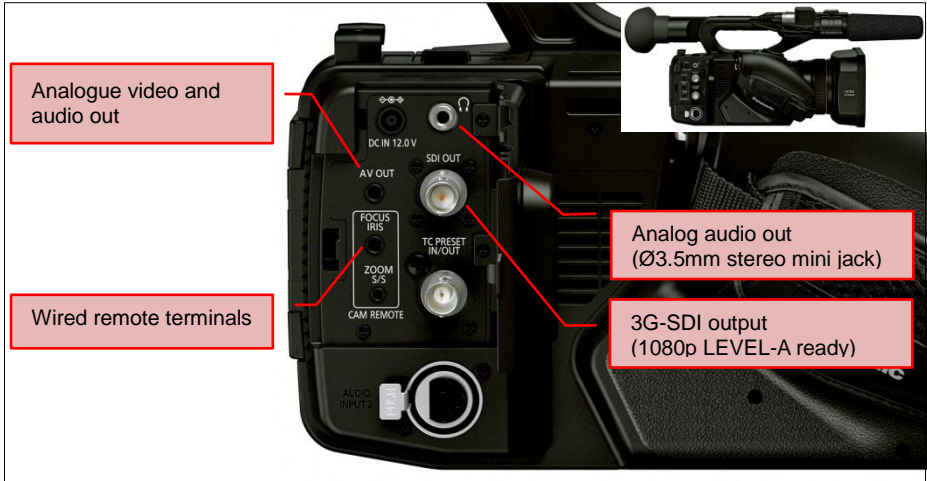

# 2. Preparation before shooting

UX180 UX90

## 2-1. Major IN/OUT connectors (AG-UX90)

Image resolution of HDMI and VIDEO OUT signals vary and will depend on the system settings. See 7-2. Output signal (P.66) for the details.

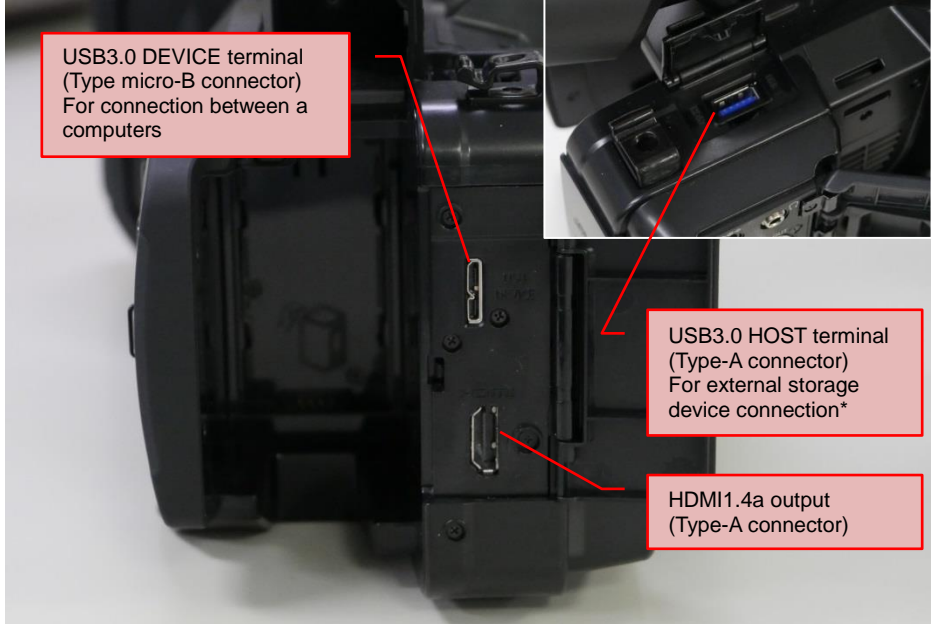
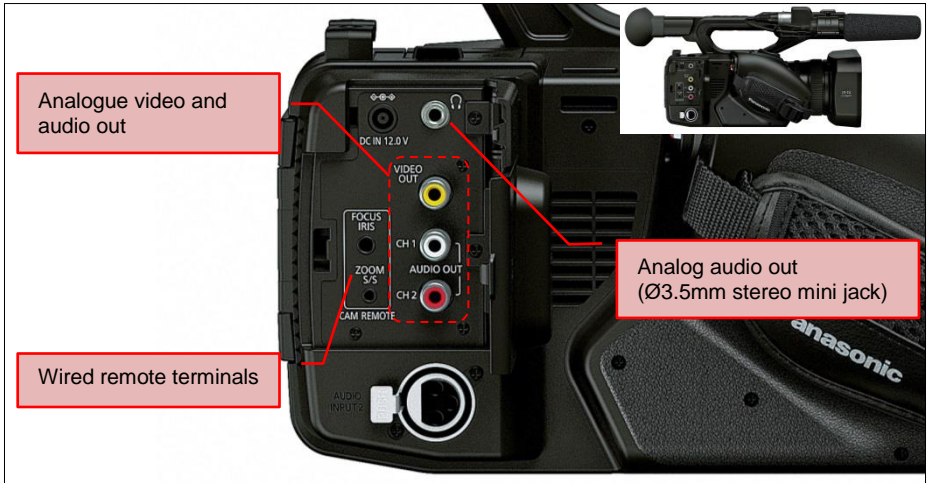

# 2. Preparation before shooting

## 2-2. Record mode settings

Set the record file format type, frequency, etc. with MENU > "SYSTEM MODE" where the following menu items are available.

### MENU > SYSTEM MODE

- SYSTEM FREQ : 59.94Hz or 50.00Hz (AG-UX180 only)
- REC MODE : MOV, MP4 or AVCHD
- REC FORMAT : Choose a combination of the number of pixels and bitrate (see P.66)

## 2-3. Audio input settings

The AG-UX series can handle up to 2 channels of audio and record them.

1. Set **CH SELECT switches (A)** for audio source selection (built-in MIC / external)
2. When external input is chosen, set attenuation type (LINE, MIC) and phantom powering option with **INPUT1/2 switches (B)**. Input levels for LINE and MIC inputs can be set with MENU > AUDIO SETUP.
3. Set record level adjustment mode (AUTO / MANUAL) with MENU > AUDIO LEVEL CH1/CH2.

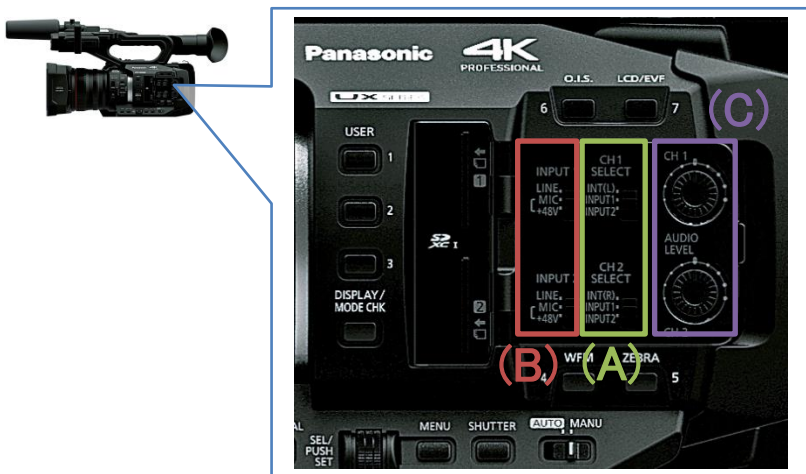

Audio record level can be set with the **AUDIO LEVEL knob (c)** when set to MANUAL.

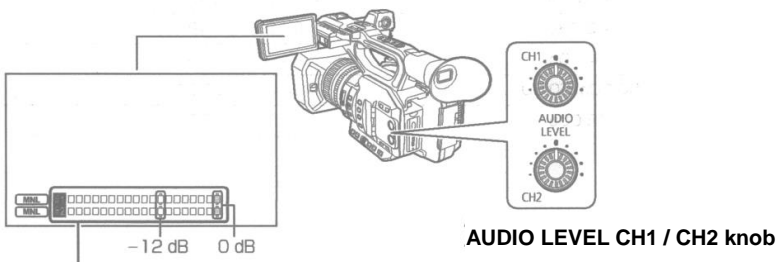

Audio level meter

## 2. Preparation before shooting

### 2-4. Record modes and required speed class of SD memory cards

SD memory cards require a higher writing speed when recording at high bitrates. The following table shows the minimum speed class necessary for each bitrate.

Record mode	Record bit rate	Minimum required speed class	Speed class symbols
MOV/MP4	100Mbps or higher (Incl. VFR and Super slow modes)	UHS Speed Class3 (*1)	<b>U3</b>
	50Mbps	UHS Speed Class1	<b>U1</b>
		Class10	<b>CLASS10</b>
AVCHD	5 to 28Mbps	Class4	<b>CLASS4</b>

\*1: For AG-UX180 only, if “UHD 2160/59.94p 150M” or “UHD 2160/50.00p 150M” record mode is selected, your chosen SD memory card needs to meet or exceed 64GB SDXC, UHS Speed Class3 specifications. Only cards of this type can be used.

\* UHS-II SD memory cards are not supported.

### 2-5. Mounting to Tripod

The AG-UX series has two different standard screw sizes, industrial standard **1/4-20UNC** size and broadcast equipment standard **3/8-16UNC** size.

Use screws shorter than 5.5mm in length, otherwise damage may occur to internal parts.



# 3. MENU settings



# 3. MENU settings

## 3-1. MENU items overview

### MENU

— SCENE FILE (Image related settings)	[P.16]
— SYSTEM MODE (Fundamental settings such as CODEC etc.)	[P.18]
— USER SW (Assign functions to USER buttons)	[P.19]
— SW SETUP (Gain, WB and other operation related settings)	[P.21]
— AUTO SW (Function assignment for full auto mode)	[P.26]
— RECORD SETUP (Recording related such as Pre-REC, TC set)	[P.27]
— AUDIO SETUP (Input gain and other audio related settings)	[P.28]
— OUTPUT SETUP (HDMI, SDI, EVF/LCD output related settings)	[P.29]
— DISP SETUP (Selection of items to be shown on EVF etc.)	[P.30]
— OTHER FUNCTIONS (Media format, calendar setting etc.)	[P.32]
— NETWORK SETUP (Wi-Fi related settings)	[P.33]
— MAINTENANCE (Firmware version display etc.)	[P.33]

### 3. MENU settings

#### SCENE FILE

Menu item	Description	Value (Factory default setting underlined)
<b>FILE SELECT</b>	Recall scene files.	F1: / F2:FLUO / F3:SPARK / F4:STILL / F5:CINE V / F6:CINE D
<b>LOAD/SAVE</b>	Load / Save custom scene files to/from SD memory cards.	LOAD / SAVE
<b>MASTER DETAIL</b>	Adjust image contour correction level for entire image.	-31 - <u>0</u> - +31
<b>DETAIL CORING</b>	Adjust threshold level of image contour correction.	0 - <u>1</u> - 60
<b>SKIN TONE DETAIL</b>	Adjust level of softness effect for a certain color tone (flesh tone).	ON / <u>OFF</u>
<b>V DETAIL LEVEL</b>	Adjust image contour correction level for vertical direction.	-7 - <u>0</u> - +7
<b>RB GAIN CONTROL SETTING</b>	Adjust color balance for each white balance memory position (A, B and PRST).  This item does not function when white balance mode is set to ATW, P3200K, P5600K, or VAR.	R GAIN: -30 - <u>0</u> - +30 B GAIN: -30 - <u>0</u> - +30 GAIN OFFSET: ON / <u>OFF</u>
<b>CHROMA LEVEL</b>	Adjust saturation of color.	-70 - <u>0</u> - +30
<b>CHROMA PHASE</b>	Adjust tone of color.	-31 - <u>0</u> - +31
<b>MATRIX</b>	Recall color presets.	NORM1: Suitable for shooting outdoors or indoors under halogen lighting. NORM2: Color is slightly more vivid than "NORM1". FLUO: Suitable for shooting indoors under fluorescent lighting. CINE-LIKE: Suitable for shooting with cinema-like image. STILL-LIKE: Suitable for shooting with digital camera-like image.
<b>COLOR CORRECTION SETTING (AG-UX180 only)</b>	Adjust color tone and saturation. This has an effect on 16 different individual color phases.	-63 - <u>0</u> - +63
<b>MASTER PED</b>	Adjust master black level	-150 - <u>0</u> - +150



### 3. MENU settings

#### SCENE FILE <continued>

Menu item	Description	Value (Factory default setting underlined)
<b>GAMMA MODE</b>	Choose image contrast and gradation according to the scene.	<u>HD</u> / SD / FILMLIKE1 / FILMLIKE2 / FILMLIKE3 / CINE-LIKE V / CINE-LIKE D / STILL-LIKE  See P.52 for details about differences among the effects of these gamma modes.
<b>BLACK GAMMA</b>	Adjusts gamma characteristics in darker signal areas.	-8 - <u>0</u> - +8
<b>KNEE MODE</b>	Set operation mode of knee function (compress bright areas to avoid an overexposed image).	<u>AUTO</u> / MANUAL / OFF
<b>KNEE MASTER POINT</b>	Sets the signal level where video image compression begins.	80.0 - <u>93.0</u> - 107.0
<b>KNEE MASTER SLOPE</b>	Adjusts slope angle when in MANUAL KNEE mode.	0 - <u>85</u> - 99
<b>DRS</b>	Turn ON/OFF Dynamic Range Stretcher (DRS) function.	ON / <u>OFF</u>
<b>DRS EFFECT</b>	Set effect level of DRS	<u>1</u> / 2 / 3  Better results of dynamic range stretcher can be expected when a higher number is chosen. However, noise level will also become higher.
<b>AUTO IRIS LEVEL</b>	Turn ON/OFF automatic aperture level control.	<u>ON</u> / OFF
<b>AUTO IRIS LEVEL EFFECT</b>	Set the target brightness level in auto iris mode.	-50 - <u>0</u> - +50
<b>NR CONTROL</b>	Sets noise reduction level. Effect becomes stronger when value is increased, and image aliasing could be seen in exchange for that.	-7 - <u>0</u> - +7

# 3. MENU settings

## SYSTEM MODE

Menu item	Description	Value (Factory default setting underlined)
<b>SYSTEM FREQ (AG-UX180 only)</b>	Set system frequency	<u>59.94Hz</u> / 50.00Hz
<b>REC MODE</b>	Set record file format.	MOV / <u>MP4</u> / AVCHD
<b>REC FORMAT</b>	Set image quality of video to be recorded. (resolution, frame rate, and bit-rate)	Available formats vary depending on the system frequency and REC mode settings. See P.66 for the details.
<b>ASPECT CONVERT</b>	Set image aspect ratio when REC FORMAT is set to SA 480/59.94i.	<u>SIDE CROP</u> / SQUEEZE
<b>EXTENDED SENSITIVITY</b>	Expand adjustable range of gain While this function is ON: -3dB to 24dB While this function is OFF: 0dB to 24dB	ON / <u>OFF</u> "EX.SENS" is indicated on the EVF while this items is set to ON.
<b>HIGH SENS MODE * (AG-UX180 only)</b>	Set camera sensitivity mode. HIGH SENS mode is suitable for shooting in dark environments.	<u>NORMAL</u> / HIGH SNES "H.SENS" is indicated on the viewfinder while this mode is activated.
<b>LOW LIGHT MODE (AG-UX90 only)</b>	Set camera sensitivity mode. LOW LIGHT mode is suitable for shooting in dark environments.	<u>OFF</u> / ON It can be turned ON when AUTO/MANUAL selector is set to "AUTO".
<b>FLASH BAND COMPENSATION</b>	Turn ON/OFF the image compensation function, which allows removing flash-band effects from an image.	ON / <u>OFF</u>
<b>CAMERA NUMBER SET</b>	Set camera identification number. This number is used as a part of footage folder's title when MOV or MP4 file format is selected.  See P.61 for the footage folder name structure.	<u>0</u> - 16

\* HIGH SENS mode does not function when one of following features is enabled

- Super slow record mode
- Variable Frame Rate (VFR) mode
- Freeze frame

# 3. MENU settings

## USER SW feature

Features can quickly be recalled from 13 user assignable buttons. (9 of them are physical buttons and 4 are available as a part of the touch screen.)

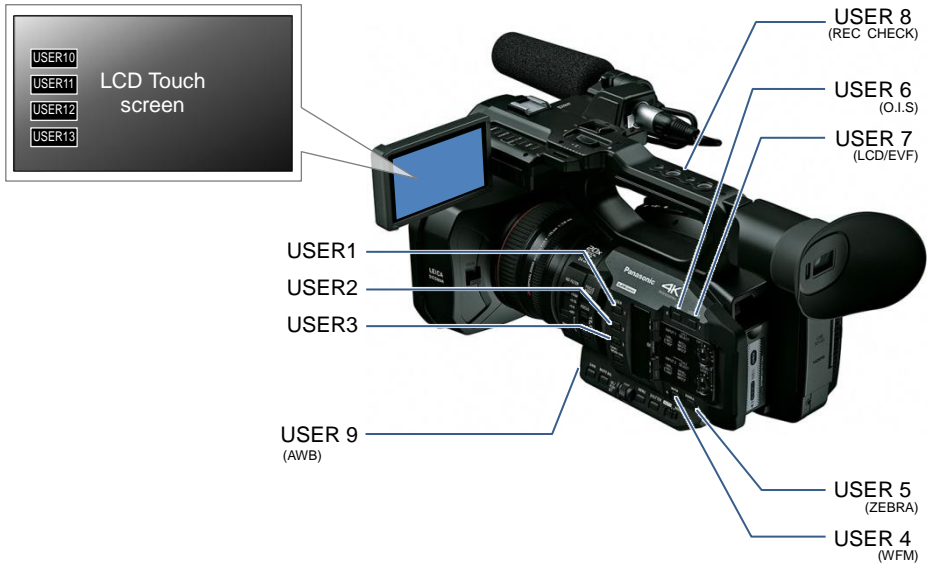

**How to assign?** MENU > USER SW > Assign any function to any button.

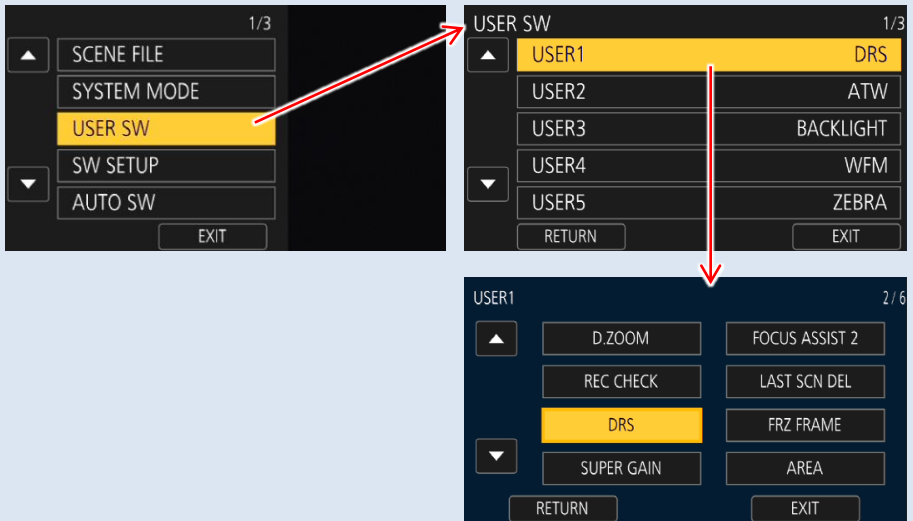

\* See next page for assignable functions including their details.

### 3. MENU settings

#### USER SW

The following table shows all functions that can be assigned to the USER buttons.

Menu item	Description
<b>INHIBIT</b>	The USER button is disabled (nothing is assigned).
<b>FOCUS ASSIST1,2</b>	Turn ON/OFF the FOCUS ASSIST function. See 4-2. Understanding Focus assist features (P.36) for further details of this function.
<b>BACKLIGHT</b>	Switch auto iris mode to backlight mode. The backlight mode can prevent underexposure when the lighting is illuminating from behind the subject.
<b>SPOTLIGHT</b>	Switch auto iris mode to Spotlight mode. The spotlight mode optimizes iris control behavior when the contrast around the subject is high (example: the subject is a spot light etc.)
<b>BLACK FADE</b>	Apply fade-in/out effect to video (black) and audio.
<b>WHITE FADE</b>	Apply fade-in/out effect to video (white) and audio.
<b>ATW</b>	Switch white balance mode to ATW (Auto Tracking White).
<b>ATW LOCK</b>	Fix the white balance aligned by ATW mode.
<b>D.ZOOM</b>	Use Digital Zoom (electronic image magnification) feature. The magnification ratio can be chosen from x2, x5, x10, or can be toggled through them.
<b>REC CHECK</b>	Plays last 2 seconds of the last recorded clip on the SD memory card.
<b>LAST SCN DEL</b>	Delete the last clip from the SD memory card.
<b>DRS</b>	Turn ON/OFF the dynamic range stretcher function. The DRS works to minimize saturated blacks and overexposure. Its effect level can be adjusted using the "DRS EFFECT" item of the SCENE FILE menu.
<b>FRZ FRAME</b>	Turn ON/OFF freeze frame feature. A still image is on the screen while this feature is working.
<b>SUPER GAIN</b>	Turn ON/OFF the Super Gain control. The gain value to be boosted can be set using the "SUPER GAIN" item of the SW SETUP menu. [SUPER GAIN values that can be set] - 30dB or 36dB
<b>AREA</b>	The following features can be enabled by touching (pointing) the subjects on the built-in LCD screen.  [Selectable items for AREA mode] INH: No function is assigned. FOCUS: Adjust the focus so that the pointed subject is in focus. IRIS: Adjust the iris so that aperture level is appropriate for the pointed subject. Y GET: Indicate Y level of the pointed subject. FOCUS/IRIS: Adjust both focus and iris for the pointed subject. FOCUS/YGET: Adjust focus and indicate Y level of the pointed subject.
<b>HISTOGRAM (AG-UX90 only)</b>	Display distribution of brightness of the image for a quick check of exposure. The histogram chart consists of "brightness" on the horizontal axis, and "frequency of appearance" on the vertical axis.
<b>FOCUS TRANS (AG-UX180 only)</b>	Execute FOCUS TRANSITION (recalling focus position presets) function. See 4-7. Understanding Focus transition (P.41) for the details.
<b>PUSH AUTO</b>	Focus mode becomes AUTO while keep pressing the button in MANUAL focus mode.

### 3. MENU settings

#### USER SW <continued>

The following table shows all functions that can be assigned to the USER buttons.

Menu item	Description
<b>EVF/LCD DETAIL</b>	Make focusing easier by enhancing the subject's edge on the viewfinder and built-in LCD monitor. The level of this enhancement and the frequency can be set using the "EVF/LCD PEAK LEVEL" and "EVF/LCD PEAK FREQ." items of the DISP menu.
<b>IR REC (AG-UX180 only)</b>	Turn ON/OFF the Infrared shooting mode.
<b>LOW LIGHT (AG-UX90 only)</b>	Set camera sensitivity mode. LOW LIGHT mode is suitable for shooting in dark environments.
<b>LEVEL GAUGE</b>	Display a level gauge on the viewfinder for the horizontal and vertical axis'. Inclinations can be indicated up to approx. 45 degrees in the horizontal, and up to approx. 10 degrees in the vertical directions.
<b>BACK GROUND (AG-UX180 only)</b>	Start or pause the recording in slot No.2 when the "Background record function" is enabled.
<b>FLASH BAND</b>	Turn ON/OFF the image compensation function, which allows removing flash-bands from the image.
<b>PRE-REC</b>	Turn ON/OFF the pre-record mode. This mode allows the camera to start recording video and audio approx. 4 sec (in MOV/MP4 mode, 3 sec in the AVCHD mode) before the REC/PAUSE button is pressed.
<b>WFM (AG-UX180 only)</b>	Display the Waveform or Vector scope on the built-in LCD monitor. Open the "WFM TYPE" item of the SW SETUP menu to select the item (Waveform or Vector scope).
<b>FAST ZOOM</b>	Increase servo zoom speed. <i>Note: When this feature is turned ON, motor's operation sound becomes louder, and may be audible and recorded.</i>
<b>EVF ON/OFF (AG-UX180 only)</b>	Turn ON/OFF the EVF display.
<b>A.IRIS LEVEL</b>	Turn ON/OFF the level adjustment mode for auto iris.
<b>ZEBRA</b>	Turn ON/OFF the ZEBRA indicator.
<b>O.I.S</b>	Turn ON/OFF the optical image stabilizer.
<b>SCENE FILE</b>	Save or load scene file data between an SD memory card and the camera.
<b>AUTO REC</b>	Turn ON/OFF sending the embedded REC-Start/-Stop signal to external recorders connected via SDI OUT.
<b>AF AREA</b>	Adjust the size of window where auto focus (AF) is enabled via jog dial.
<b>VFR</b>	Turn ON/OFF variable frame rate mode.
<b>FOCUS MACRO</b>	Turn ON/OFF the macro mode. With macro mode ON, focus adjustable range at Wide-end is from 10cm to infinity. (With macro mode OFF, from 1meter to infinity.)
<b>i. ZOOM</b>	Turn ON/OFF the "i.Zoom" mode which allows the camera to magnify the image (electronically) up to x30 (x25 for AG-UX90) at the Tele-end. This mode can only be enabled when resolution setting is 1920x1080 or lower.
<b>USB MODE</b>	Enable/disable the USB connection mode.
<b>AWB</b>	Perform auto white balance adjustment.

### 3. MENU settings

#### USER SW <continued>

The following table shows all functions that can be assigned to the USER buttons.

Menu item	Description
<b>SUPER SLOW (AG-UX180 only)</b>	Turn ON/OFF super slow record mode
<b>SLOT SEL</b>	Select card slot to be recorded or playback.
<b>LCD/EVF OUTPUT</b>	Select the display device. (Always displayed on either Built-in LCD monitor or EVF, or automatically switched by the eyepiece sensor)
<b>LOW GAIN</b>	Set gain value for LOW gain position
<b>MID GAIN</b>	Set gain value for MID gain position
<b>HIGH GAIN</b>	Set gain value for HIGH gain position
<b>MENU</b>	Open MENU.

### 3. MENU settings

#### SW SETUP

Menu item	Description	Value (Factory default setting underlined)	
IRIS RING	Set the IRIS control direction of the IRIS ring.	<u>DOWN OPEN</u> / UP OPEN	
LOW GAIN	Set GAIN value when the gain selector is set to "L".	AG-UX180 AG-UX90	AUTO - <u>0dB</u> – 24dB AUTO - <u>0dB</u> – 30dB
MID GAIN	Set GAIN value when the gain selector is set to "M".	AG-UX180 AG-UX90	AUTO - <u>6dB</u> – 24dB AUTO - <u>6dB</u> – 30dB
HIGH GAIN	Set GAIN value when the gain selector is set to "H".	AG-UX180 AG-UX90	AUTO - <u>12dB</u> – 24dB AUTO - <u>12dB</u> – 30dB
SUPER GAIN	Set GAIN value in the SUPER GAIN mode, which is available as one of the user assignable functions.	AG-UX180 AG-UX90	<u>30dB</u> / 36dB <u>33dB</u> / 36dB
O.I.S	Turn ON/OFF optical image stabilizer.	<u>ON</u> / OFF	
HYBRID O.I.S	Turn ON/OFF electrical image stabilizer which works in addition to the optical one.	<u>ON</u> / OFF	
CUSTOM O.I.S	OIS characteristic customization (Blur Amplitude and Frequency) can be used when this item is set to ON.	ON / <u>OFF</u>	
BLUR AMPLITUDE	Customize characteristic of amplitude swing for OIS.	1 / 2 / <u>3</u> / 4 / 5	
BLUR FREQ	Customize characteristic of frequency swing for OIS.	1 / <u>2</u> / 3	
ATW SET	Assign Auto Tracking White (ATW) to any position of WHITE BAL selector.	<u>OFF</u> / Ach / Bch / PRST	
ATW TARGET R	Fine-tune the ATW adjustment result (to make it more/less Reddish).	-10 - <u>0</u> - +10	
ATW TARGET B	Fine-tune the ATW adjustment result (to make it more/less Blueish).	-10 - <u>0</u> - +10	
WB PRESET	Set white balance mode when WHITE BAL selector is set to PRST.	<u>3200K</u> / 5600K / VAR* *VAR : Variable	
WB VAR	Adjust color temperature of the image when WB PRESET is set to VAR (variable) mode.	2000K – <u>3200K</u> – 15000K	
MF ASSIST (AG-UX180 only)	Focus mode is momentarily set to "AUTO" immediately after manual focusing.	ON / <u>OFF</u>	
FOCUS ASSIST1	Set focus assist type	EXPAND / PEAKING / <u>BOTH</u>	
FOCUS ASSIST2	Set focus assist type	<u>EXPAND</u> / PEAKING	

# 3. MENU settings



## SW SETUP <continued>

Menu item	Description	Value (Factory default setting underlined)
<b>PEAKING COLOR</b>	Set highlighting color for the peaking focus assist.	<u>Red</u> / Blue / Yellow / White
<b>PEAKING LEVEL</b>	Set highlighting level of the peaking focus assist.	-7 - <u>0</u> - +7
<b>FOCUS RING DRIVE</b>	Set the type of focus control by the focus ring.	<u>SPEED(*)</u> / COARSE / FINE * Focus control speed varies in response to rotation speed of the focus ring.
<b>FOCUS MACRO</b>	Turn ON/OFF macro mode.	ON / <u>OFF</u> Focus adjustable range at wide-end is from 10cm to infinity with MACRO: ON. (from 1meter to infinity with MACRO: OFF).
<b>AREA MODE</b>	Choose the feature that works when tapping the subject on the built-in LCD.	INH, FOCUS, IRIS, YGET, <u>FOCUS/IRIS</u> , FOCUS/YGET  INH: No function is assigned. FOCUS: Adjust the focus so that the pointed subject is in focus. IRIS: Adjust the iris so that aperture level is appropriate for the pointed subject. Y GET: Indicate Y level of the pointed subject. FOCUS/IRIS: Adjust both focus and iris for the pointed subject. FOCUS/YGET: Adjust focus and indicate Y level of the pointed subject.
<b>CUSTOM AF</b>	AF characteristic customization (AF Speed and sensitivity) can be used when this item is set to ON.	ON / <u>OFF</u>
<b>AF SPEED</b>	Set speed of auto focus control.	-5 - <u>0</u> - +5
<b>AF SENSITIVITY</b>	Set sensitivity of auto focus control.	0 - <u>5</u> - 10
<b>AF AREA WIDTH</b>	Set the size of window where auto focus is enabled.	Use the jog-dial to adjust window size.
<b>WFM (AG-UX180 only)</b>	Display the Waveform or Vector scope.	ON / <u>OFF</u>
<b>WFM TYPE (AG-UX180 only)</b>	Choose WFM display type.	<u>WAVE</u> , VECTOR, WAVE/VECTOR
<b>WFM POSITION (AG-UX180 only)</b>	Set WFM display position.	<u>TOP/LEFT</u> / TOP/RIGHT / BOTTOM/LEFT / BOTTOM/RIGHT
<b>ZEBRA</b>	Set type of light indication (Zebra or Spot meter).	ZEBRA1 / ZEBRA2 / MARKER / <u>OFF</u>



# 3. MENU settings

## SW SETUP <continued>

Menu item	Description	Value (Factory default setting underlined)
ZEBRA MODE	Set the display period of ZEBRA.	<u>CONTINUE</u> / MOMENT (5sec)
BARS TYPE	Set the type of color bars.	<p>TYPE 1</p>  <p>TYPE 2</p>  <p>TYPE 3</p> 
SUB REC BUTTON	Use one of the REC buttons on the carrying handle.	<u>ACTIVE</u> / INHIBIT
FAST ZOOM	Increase servo zoom speed.	ON / <u>OFF</u> <i>Note: When this feature is turned ON, motor operation sound becomes louder, and could be audible and recorded.</i>
SUB ZOOM	Use one of the zoom levers on the carrying handle.	OFF / 1 / 2 / 3 / 4 / <u>5</u> / 6 / 7  * Zoom speed becomes faster as the number increases.
DIGITAL ZOOM	Set magnification ratio of the digital zoom.	x2 / x5 / x10 / <u>TOGGLE</u>
i. ZOOM	Activate electronic image zoom feature, which can extend zoom ratio up to x30 (x25 for AG-UX90) while maintaining a certain image quality.	ON / <u>OFF</u>  * Enabled when resolution setting is 1920x1080 or lower.
ZOOM/FOCUS	Set a way to operate ZOOM and FOCUS while under controlled from the AG ROP app. (see P.42)	<u>IP REMOTE</u> / CAMERA

# 3. MENU settings

## AUTO SW

Whether to use the following features or not can be individually selected while in the automatic mode.



**A** symbol is indicated on the viewfinder / built-in LCD screen while this mode is set to AUTO.



Menu item	Description	Value (Factory default setting underlined)
<b>A.IRIS</b>	Auto iris	<u>ON</u> / OFF
<b>AGC</b>	Auto gain control	<u>ON</u> / OFF
<b>AGC LIMIT</b>	Set the upper limit of the amplifier while in AUTO mode.	3 / 6 / 9 / <u>12</u> / 15 / 18 / 21 / 24 / 27 / 30dB
<b>AUTO SHUTTER</b>	Auto shutter	<u>ON</u> / OFF
<b>AUTO SLOW SHTR</b>	Set auto slow shutter mode (ON or OFF) while in AUTO mode. The auto slow shutter mode adjusts shutter speed (to make it slower) when light intensity is not sufficient.	ON / <u>OFF</u>
<b>ATW</b>	Auto Tracking White	<u>ON</u> / OFF
<b>AF</b>	Auto Focus	<u>ON</u> / OFF

# 3. MENU settings

## RECORD SETUP

Menu item	Description	Value (Factory default setting underlined)
<b>MEDIA SELECT</b>	Select media slot for recording.	<u>SD CARD1</u> / <u>SD CARD2</u>
<b>2SLOT FUNC.</b>	Set the record mode, which uses dual memory card slots.	<u>OFF</u> / <u>RELAY</u> / <u>SIMULTANEOUS</u> / <u>BACKGROUND(*1)</u> / <u>DUAL CODEC(*1)</u> See P.37 for the details. *1: AG-UX180 only
<b>DUAL CODEC REC (AG-UX180 only)</b>	Select the codec for sub recording. Available in DUAL CODEC mode only.	FHD 50Mbps / <u>FHD 8Mbps</u>
<b>INTERVAL REC</b>	Set record interval time (pause time) of time-lapse recording.	<u>OFF</u> / <u>1SEC</u> / <u>10SEC</u> / <u>30SEC</u> / <u>1MIN</u> / <u>2MIN</u>
<b>VFR MODE</b>	Turn ON/OFF variable frame record mode.	ON / <u>OFF</u>
<b>FRAME RATE</b>	Adjust frame rate. Adjustable range is from 2fps to 60fps	30fps
<b>SUPER SLOW (AG-UX180 only)</b>	Record at 120fps (59.94Hz mode) or 100fps (50Hz mode)	ON / <u>OFF</u>
<b>PRE-REC</b>	Turn ON/OFF the pre-record mode. This mode allows the camera to start recording the video and audio (approx. 4 sec in the MOV/MP4 mode, 3 sec in the AVCHD modes) before the REC button is pressed.	ON / <u>OFF</u>
<b>INFRARED REC (AG-UX180 only)</b>	Turn ON/OFF the infrared record mode, allowing image capture in dark locations.	ON / <u>OFF</u>
<b>IR REC COLOR (AG-UX180 only)</b>	Set color of video image in INFRARED REC mode	<u>Green</u> / <u>White</u>
<b>FOCUS TRANSITION (AG-UX180 only)</b>	Register positions for focus transition function. (See P.41)	SET / <u>OFF</u>
<b>FOCUS TRANSITION TIME (AG-UX180 only)</b>	Set transition time from one position to another.	Direct/ Fastest / <u>2</u> – 15sec / 20sec / 30sec / 45sec / 60sec / 90sec
<b>FOCUS TRANSITION REC (AG-UX180 only)</b>	Execute the focus transition function as soon as REC button is pressed. This menu item selects which position to start with.	1 / 2 / 3 / <u>OFF</u>
<b>FOCUS TRANSITION WAIT (AG-UX180 only)</b>	Set pause time until focus transition starts.	<u>0sec</u> / 5sec / 10sec
<b>TIME STAMP</b>	Allows recording of superimposed date and time on the image.	ON / <u>OFF</u>
<b>DF MODE</b>	Set timecode drop frame mode.	<u>DF</u> / <u>NDF</u>
<b>TCG</b>	Set timecode count mode.	FREE RUN / <u>REC RUN</u>
<b>TC PRESET</b>	Set initial value of timecode.	--
<b>UB PRESET</b>	Set value of users bit	Available in AVCHD mode only.
<b>EXT TC LINK (AG-UX180 only)</b>	This item is for timecode synchronization for multi camera recording purpose. (See P.38)	MASTER / SLAVE

# 3. MENU settings

## AUDIO SETUP

Menu item	Description	Value (Factory default setting underlined)
AUDIO LOW CUT CH1	Reduce the level of low frequency sound on audio channel 1.	ON / <u>OFF</u>
AUDIO LOW CUT CH2	Reduce the level of low frequency sound on audio channel 2.	ON / <u>OFF</u>
AUDIO LEVEL CH1	Set audio level adjustment mode for audio channel1.	<u>AUTO</u> / MANUAL
AUDIO LEVEL CH2	Set audio level adjustment mode for audio channel2.	<u>AUTO</u> / MANUAL
AUDIO ALC LINK	Auto Level Control (ALC) effect links audio CH1 and CH2. When this item is set to "ON", ALC works on both CH1 audio and CH2 audio.	ON / <u>OFF</u>  Set the following switch and menu to use this feature. - Set CH1 and CH2 to MANU - Set both AUDIO ALC CH1 and CH2 menu items to "ON".
AUDIO ALC CH1	Use Auto Level Control on audio channel 1.	<u>ON</u> / OFF
AUDIO ALC CH2	Use Auto Level Control on audio channel 2.	<u>ON</u> / OFF
INPUT1 LINE LEVEL	Set audio level of audio channel 1. (LINE level)	+4dBu / <u>0dBu</u>
INPUT2 LINE LEVEL	Set audio level of audio channel 2. (LINE level)	+4dBu / <u>0dBu</u>
INPUT1 MIC LEVEL	Set audio level of audio channel 1. (MIC level)	-40dB / <u>-50dB</u> / -60dB
INPUT2 MIC LEVEL	Set audio level of audio channel 2. (MIC level)	-40dB / <u>-50dB</u> / -60dB





# 3. MENU settings

## OUTPUT SETUP

Menu item	Description	Value (Factory default setting underlined)
<b>OUTPUT SEL</b> (AG-UX180 only)	Select video and audio output.	<u>HDMI</u> / SDI / AV
<b>RESOLUTION</b>	Set resolution of output video signal.	<u>SYSTEM</u> / 1080p / 1080i / DOWN CONV. The type of signal available on the output varies and will depend on REC format setting. See P.66 for the details.
<b>REMOTE REC</b>	Inserts the REC/PAUSE trigger signal on SDI (AG-UX180) or HDMI OUT. This allows the camera to control REC/PAUSE functions of an external recorder.	ON / <u>OFF</u>
<b>REMOTE REC LINK</b>	Set the way to control the remote REC/PAUSE of an external recorder.	ON: Remote REC/PAUSE can be performed with the REC button. <u>OFF</u> : Remote REC/PAUSE can be performed with the user assignable buttons (AUTO REC function).
<b>SDI EDH</b> (AG-UX180 only)	EDH signal is embedded in the SDI stream. Enabled in 480i mode only.	<u>ON</u> / OFF
<b>SDI AUDIO GAIN CHG</b> (AG-UX180 only)	Set the audio gain of SDI embedded audio signal.	<u>0dB</u> / -6dB / -12dB
<b>DOWN CONV.</b>	Set the display mode of a down converted image.	SIDE CROP / LETTERBOX / <u>SQUEEZE</u>
<b>HDMI UHD OUTPUT LIMIT</b> (AG-UX180 only)	Set the frame rate limit of HDMI OUT while in UHD 2160/59.94p 150M and UHD 2160/50.00p 150M record modes.	System freq = 59.94Hz <u>59.94p</u> : Output in 2160/59.94p 29.97p: Output in 2160/29.97p System freq = 50.00Hz 50.00p: Output in 2160/50.00p 25.00p: Output in 2160/25.00p
<b>HDMI TC OUTPUT</b>	Insert timecode signal on HDMI OUT.	ON / <u>OFF</u>
<b>AV OUT</b> (AG-UX90 only)	Select video and audio output. HDMI OUT works when set to OFF.	<u>OFF</u> / ON
<b>H/PHONE MODE</b>	Select audio output mode on headphones out and AV out. Choose "LIVE" when delay is audible between audio and actual sound.	LIVE / <u>RECORDING</u>  Fixed to "RECORDING" when an HDMI cable connected.
<b>VOLUME</b>	Headphone volume adjustments can be made with the built-in jog dial.	<u>ON</u> / OFF
<b>TEST TONE</b>	Set the test tone level.	<u>OFF</u> / LEVEL1 (loud) / LEVEL2 (low)
<b>LCD/EVF OUTPUT</b>	Set the way to use the LCD and EVF monitors.	AG-UX180 <u>AUTO</u> /LCD AG-UX90 <u>LCD</u> / EVF

# 3. MENU settings

## DISP SETUP

Menu item	Description	Value (Factory default setting underlined)
ZEBRA DETECT1	Set the zebra pattern (right downward). 	50% - <u>80%</u> - 105%
ZEBRA DETECT2	Set the zebra pattern (right upward). 	50% - <u>100%</u> - 105%
MARKER	Display the spot meter marker.	<u>ON</u> / OFF
GUIDE LINES	Select and show the guide line pattern.	 /  /  / OFF
SAFETY ZONE	Select and show the safety zone marker.	16:9 <u>90%</u> / 4:3 / 14:9 / 1.85:1 / 2:1 / 2.35:1 / 2.39:1 / OFF *The following items can be selected when SA 480i mode is selected and "SIDE CROP" is selected for the ASPECT CONV menu item. ➔ 4:3 <u>90%</u> / 4:3 / OFF
CENTER MARKER	Show the center marker.	<u>ON</u> / OFF
REC COUNTER	Set the counting method of record counter.	TOTAL / <u>SCENE</u>
FOCUS DISPLAY	Set the unit of focus position to be displayed.	<u>NUMBER</u> / feet / m / OFF
ZOOM DISPLAY	Set the unit of zoom position to be displayed.	<u>NUMBER</u> / mm / OFF
VIDEO OUT OSD	Show the EVF characters on an external video monitor.	ON / <u>OFF</u>
DATE/TIME	Set the display format of date and time.	<u>OFF</u> / TIME / DATE / DATE&TIME
DATE FORMAT	Set the display format of calendar.	Y/M/D, M/D/Y, D/M/Y
LEVEL GAUGE	Show a level gauge to check the pitch and roll levels.	ON / <u>OFF</u>
HISTOGRAM (AG-UX90 only)	Display distribution of brightness of the image for a quick check of exposure. The histogram chart consists of "brightness" on the horizontal axis, and "frequency of appearance" on the vertical axis.	ON / <u>OFF</u>
AUDIO LEVEL METER	Show audio level meter.	<u>ON</u> / OFF
LENS STATUS	Show the following item information. Zoom, OIS, Iris, Gain, ND filter position, focus position, white balance, shutter speed etc.	<u>ON</u> / OFF
CARD&BATTERY	Show remaining time of SD card and battery.	<u>ON</u> / OFF

### 3. MENU settings

#### DISP SETUP <continued>

Menu item	Description	Value (Factory default setting underlined)
<b>OTHER DISPLAY</b>	Show the information other than the following.  USER buttons, Guide lines, Safety zone, Center marker, Date&time, Audio level meter, Lens status, remaining time (SD card and battery)	<u>ON</u> / OFF
<b>POWER LCD</b>	Boost up brightness of LCD panel for outdoor use.	-1 / <u>0</u> / +1
<b>LCD BACKLIGHT (AG-UX180 only)</b>	Set brightness of the built-in LCD monitor.	HIGH / LOW
<b>LCD SET</b>	Adjust image characteristics of the built-in LCD monitor.	COLOR, BRIGHTNESS, CONTRAST
<b>EVF SETTING</b>	Adjust image characteristics of the viewfinder.	COLOR, BRIGHTNESS, CONTRAST
<b>EYE SENSOR (AG-UX180 only)</b>	Set sensitivity of the proximity sensor on the viewfinder.	-4 - <u>2</u> - +4
<b>SELF SHOOT</b>	Set display mode of the built-in LCD monitor. Choose "MIRROR" when performing self-portrait recording. (Image can be inverted horizontally.)	<u>MIRROR</u> / NORMAL
<b>EVF COLOR</b>	Turn OFF color image display on the Viewfinder.	<u>ON</u> / OFF
<b>EVF/LCD DETAIL</b>	Turn ON edge enhancement feature on the viewfinder and the built-in LCD monitor for easy focusing.	ON / <u>OFF</u>
<b>EVF/LCD PEAK LEVEL</b>	Set enhancement level in the EVF/LCD DETAIL setting.	-3 - <u>0</u> - +3
<b>EVF/LCD PEAK FREQ.</b>	Set enhancement frequency in the EVF/LCD DETAIL setting.	HIGH / <u>LOW</u>

### 3. MENU settings

#### OTHER FUNCTIONS

Menu item	Description	Value (Factory default setting underlined)
FORMAT MEDIA	SD cards and external drives can be formatted.	---
MEDIA STATUS	Show remaining record time of SD cards.	---
PICTURE MEDIASELECT (AG-UX180 only)	Select card slot to store still pictures.	<u>CARD1</u> / CARD2
REC LAMP	Set the tally lamp to be used during the recording.	FRONT / REAR / <u>BOTH</u> / OFF
CLOCK SET	Set the clock.	---
TIME ZONE	Set the time difference between the current location and Greenwich Mean Time (GMT).	---
ALERT SOUND	Set the beep alert volume, which occurs when touching the screen or starting/stopping recording.	[OFF] /  (Volume low) /  (Volume high)
ECONOMY (BATTERY)	Turn ON/OFF the economy mode, which automatically turns power OFF when no operation is detected for five minutes while the camera is battery-powered.	ON / <u>OFF</u> *It does not function under the following conditions. -PRE-REC is activated -While in USB connection mode
ECONOMY (AC)	Turn ON/OFF the economy mode, which automatically turns power OFF when no operation is detected for 15 minutes while AC-powered.	ON / <u>OFF</u> *It does not function under the following conditions. -PRE-REC is activated -While in USB connection mode
SYSTEM FREQ (AG-UX180 only)	Set system frequency.	<u>59.94Hz</u> / 50.00Hz
USB MODE	Enable/disable the USB connection mode	ON / <u>OFF</u>
USB MODE SELECT	Set USB connection mode.	HOST / <u>DEVICE</u> HOST: When connect to external storages. DEVICE: When connect to PC/Mac.
INITIAL SET	Restore the product to factory settings.	ALL / <u>SCENE</u> / NETWORK / <u>NO</u> SCENE: Initializes customized scene files only.
NUMBER RESET	Return the clip number to "0001" when MOV/MP4 files or still pictures are recorded next time.	---
SOFTWARE INFO	Show license information on a PC connected via USB interface.	License information can be viewed on the PC with "LICENSE.txt" generated from the camera.
LANGUAGE	Set the MENU language.	---



# 3. MENU settings

## NETWORK SETUP

Menu item	Description	Value (Factory default setting underlined)
<b>USER ACCOUNT</b>	Set a user account information for the AG ROP iPad app. (See P.42)	SET / <u>OFF</u>
<b>WIRELESS SETUP</b>	Set a connection method.	<u>DIRECT</u> / SSID(SELECT) / SSID(MANUAL)
	Sub settings when "DIRECT" is chosen. (Choose it when connect an iPad to AG-UX camera directly)  <ul style="list-style-type: none"> <li>- SSID: Network ID of the camera.</li> <li>- BAND: Frequency band to be used (<u>2.4GHz</u> / 5GHz)</li> <li>- CHANNEL (2.4GHz): Channel when a Wi-Fi adaptor (2.4GHz) is used.</li> <li>- CHANNEL (5GHz): Channel when a Wi-Fi adaptor (2.4GHz) is used.</li> <li>- Password: Password to be entered at iPad to access the camera. (Factory default: 01234567890123456789abcdef)</li> </ul>	
	Choose "SSID (SELECT)" when connect between an iPad and the camera via a Wi-Fi access point.	
	Choose "SSID (MANUAL)" when connect between an iPad and the camera via a Wi-Fi access point while configuring settings manually.  <ul style="list-style-type: none"> <li>-SSID: Network ID of the camera.</li> <li>-SECURITY TYPE: Security protocol and certification program (<u>WPA2-AES</u> / WPA-AES / WPA2-TKIP / WPA-TKIP / NONE)</li> <li>- Password: Password to be entered to access the access point.</li> </ul>	
<b>Wireless LAN setup</b>	Set network connection related items.	IP Address / Subnet Mask / Gateway / DHCP / MAC Address
<b>CONNECTION HISTORY</b>	Display access log with Wi-Fi access points.	---
<b>NETWORK INITIAL SETTING</b>	Initialize menu items under NETWORK SETUP to factory default.	---
<b>NETWORK SETUP PASSWORD</b>	Set password to allow / ban on changing NETWORK SETUP menu items.	Setup / <u>Delete</u>

## MAINTENANCE

Menu item	Description	Value (Factory default setting underlined)
<b>VERSION</b>	Show the current firmware version.	---
<b>UPDATE</b>	Executes the firmware update.	---
<b>HOURLY METER</b>	Show the following operation hours and times (cumulative)	---

# 4. Understanding advanced features



# 4. Understanding advanced features

## 4-1. Monitoring 4K & UHD image

UX180

UX90

The AG-UX180 is equipped with an **HDMI 2.0** output port (HDMI1.4a for AG-UX90). It allows the camera to output stunning UHD/59.94p or 50.00p images (UHD/29.97p for AG-UX90) in playback mode and camera through mode.

**Note:** Output image is down-converted to 1080p from UHD/59.94p or 50p once recording starts.

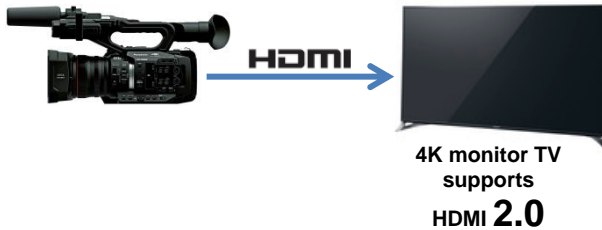

Acceptable video formats\*

4K/24.00p \*

UHD/59.94p \*\*

UHD/50.00p \*\*

UHD/29.97p

UHD/25.00p \*

UHD/23.98p

\* AG-UX180 only

\*\* In playback or camera through mode only.  
(i.e. not recording mode).

When monitor TV and/or receiver devices are not **HDMI 2.0** compliant, acceptable frame rate in the devices will usually be limited up to 29.97p at UHD. See user's guide of your device for performance specifications.

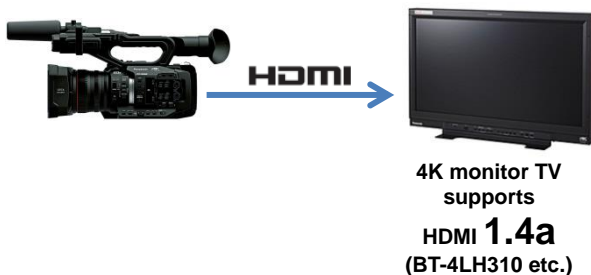

Acceptable video formats

4K/24.00p \*

UHD/29.97p

UHD/25.00p \*

UHD/23.98p

\* AG-UX180 only

When viewing UHD/59.94p and 50.00p images from AG-UX180 with a device that does not support HDMI 2.0, but equipped with Four SDI input for UHD (like the Panasonic BT-4LH310), use HDMI2.0 to HD-SDI converter such as AJA HA5-4K.

### Setting HDMI output

1. MENU > OUTPUT SETUP > OUTPUT SEL: HDMI
2. MENU > OUTPUT SETUP > RESOLUTION: SYSTEM (output signal resolution follows the system setting)

\* See 7-2. Output signal for more details.

# 4. Understanding advanced features

## 4-2. Understanding Focus assist features

UX180 UX90

The AG-UX series is equipped with following two focus assist features to make focusing easier when recording 4K/UHD higher resolution formats. Two different assist modes (EXPAND and PEAKING) can be individually recalled with USER assignable buttons.

### How to use

1. Set the FOCUS mode to MANUAL.
2. Press the FOCUS ASSIST button located at the left side of the unit or assign the FOCUS ASSIST function to any assignable USER buttons. (MENU > USER SW > any USER button number : FOCUS ASSIST1 or FOCUS ASSIST2)



3. Choose assist type to be recalled with the USER button.  
(MENU > SW SETUP > FOCUS ASSIST1 or 2: EXPAND / PEAKING / BOTH)

<p><b>EXPAND</b></p>	<p>Part of image can be magnified from 3 to 10 times. The position to be magnified can be specified by tapping the touch screen).</p> <p>Image magnification turns OFF when the REC button is hit.</p>
<p><b>PEAKING</b></p>	<p>Adding colored highlights to in-focus edges. Highlighting level can be adjusted and its color can also be selected from four different colors:</p> <p><b>MENU</b></p> <ul style="list-style-type: none"><li>&gt; SW SETUP &gt; PEAKING COLOR (Parameter: Red, Blue, Yellow, White)</li><li>&gt; SW SETUP &gt; PEAKING LEVEL: (Parameter: -7 - 0 - +7)</li></ul>

# 4. Understanding advanced features

## 4-3. Understanding Dual memory card slots

Various recording modes are available with dual SD memory card slots.

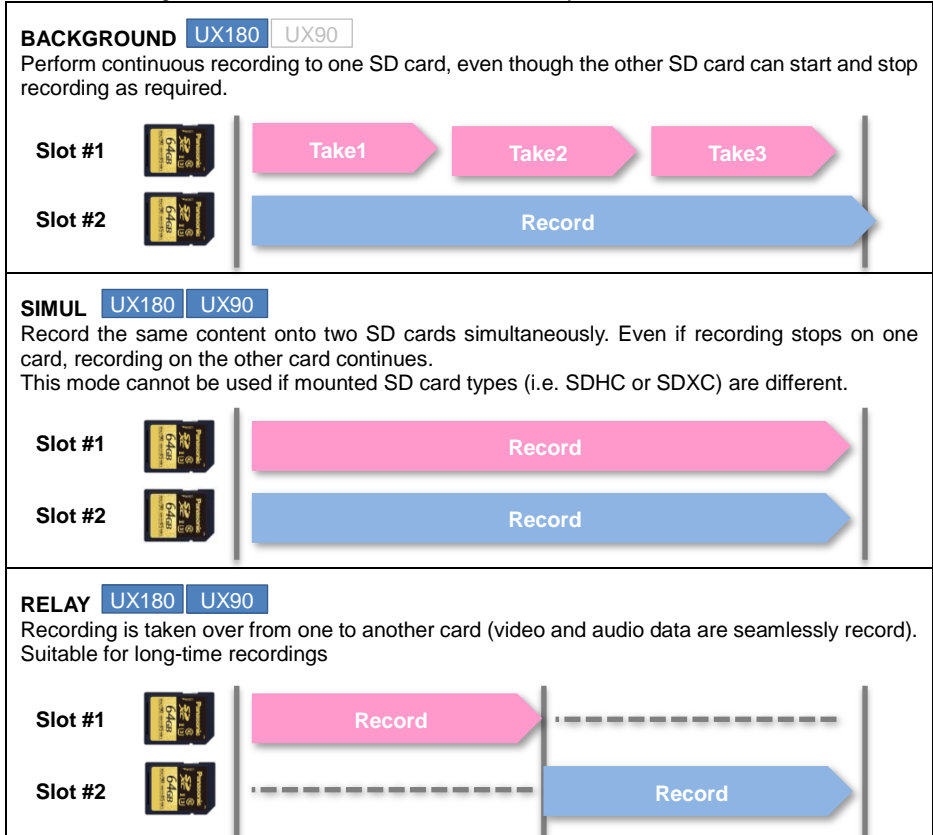

### Using the 2Slot features

MENU > RECORD SETUP > 2SLOT FUNC: OFF / RELAY / SIMUL / BACKGROUND

NOTE: RELAY and BACKGROUND modes do not function under the following conditions.

- Variable frame rate record mode (VFR) is ON.
- Interval recording mode is ON.
- Super slow mode is ON (AG-UX180)

# 4. Understanding advanced features

## 4-4. Synchronizing timecode for multi-cam operation

UX180 UX90

The AG-UX180 is equipped with a timecode IN/OUT terminal (common use for IN and OUT).

The following describes workflow know-how when using time code synchronization feature with two AG-UX180 units.



### Preparation

1. Connect TC PRESET IN/OUT terminals on both master and slave units with a BNC cable.
2. Make sure that the settings of following menu items are the same for both units.

MENU > SYSTEM MODE > REC FORMAT  
MENU > SYSTEM MODE > REC MODE  
MENU > RECORD SETUP > DF MODE (59.94Hz system mode only)

### Settings for master unit

3. Set MENU > RECORD SETUP > TCG to “FREE RUN”.
4. Set MENU > RECORD SETUP > EXT TC LINK to “MASTER” (now timecode signal is output from the TC PRESET IN/OUT terminal).

### Settings for slave unit

5. Set MENU > RECORD SETUP > EXT TC LINK to “SLAVE” (now the TC PRESET IN/OUT terminal switches to input mode, and TCG setting changes to FREE RUN automatically).
6. Press the RESET/TC SET button near the built-in LCD panel to synchronize timecode.



Note “EXT TC LINK” setting cannot set to SLAVE when following recording modes are in use.

- Variable frame rate, Interval record, Super slow modes

# 4. Understanding advanced features

## 4-5. Understanding user customizable image stabilizer

UX180 UX90

Much higher performance is required of image stabilizers for 4K/UHD cameras because even a small amount of shake can easily be seen when working in these resolutions. The AG-UX series is equipped with nine times higher stabilization performance achieved through an expanded stabilization range. The stabilization characteristics can also be customized to meet professional requirements.

Detectable and Stabilizable range comparison

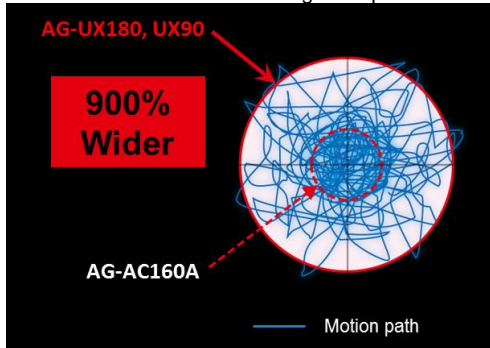

\* Except 4K 24p mode(AG-UX180)

### Customizing image stabilization characteristic

1. MENU > SW SETUP > CUSTOM O.I.S : ON
2. MENU > SW SETUP > Set "BLUR AMPLITUDE" and "BLUR FREQ" as explained below.

### BLUR AMPLITUDE adjustment

- Factory default setting = 3 (adjustable range: 1 - - - 3 - - - 5)
- Choose smaller values when motion of camera work is not so large (suitable for steady shots).
- Choose larger values when recording while moving.
- When increasing this value, OIS can compensate small to large shake levels but is not suitable for steady shots.

### BLUR FREQUENCY adjustment

- Factory default setting = 2 (adjustable range: 1, 2, 3)
- 1: Image stabilizer actively responds from rapid camera shaking to slow shaking. This mode is suitable for steady shots.
  - 2: Image stabilizer actively responds for relatively rapid shaking.
  - 3: Image stabilizer effect weakens or strengthens dynamically. Effect level becomes stronger for rapid shaking, and becomes weaker for slow shaking making it suitable for scenes that frequently use panning.

# 4. Understanding advanced features

## 4-6. Understanding user customizable auto focus

UX180 UX90

The AG-UX series is equipped with customizable auto focus to meet professional requirements.

### Customizing image stabilization characteristic

1. MENU > SW SETUP > CUSTOM AF : ON
2. MENU > SW SETUP > Set "AF SPEED" and "AF SENSITIVITY" as explained below.

### AF SPEED (focusing speed) adjustment

- Factory default setting = 0 (adjustable range: -5 - - 0 - - +5)
- Focusing speed increase as the value increases.

Note: When increasing the value of AF SPEED control, the motor operation sound becomes louder and may be recorded.

### AF SENSITIVITY (focusing response) adjustment

- Factory default setting = 5 (adjustable range: 0 - - - 5 - - - 10)
- Focusing response becomes faster as the value increases. This makes it suitable to follow fast moving objects.



# 4. Understanding advanced features

## 4-7. Understanding Focus transition feature

UX180 UX90

A new focus transition feature allows users to easily adopt impressive camera work with racking focus (changing focus of the lens during a shot). This is even available in 4K/UHD mode, where this would normally be a challenging focus operation if performed manually.



How to operate focus transition

1. Set focus mode to **MANUAL**.
2. Assign "FOCUS TRANS" to one of the USER assignable buttons (MENU > USER SW).
3. MENU > RECORDING SET UP > FOCUS TRANSITION > SET

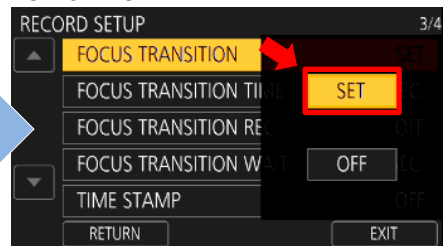

4. Choose a preset number and adjust the focus ring. In following figures, focus is set to foreground and stored in preset 1, and set focus to the plant and stored in preset 2.

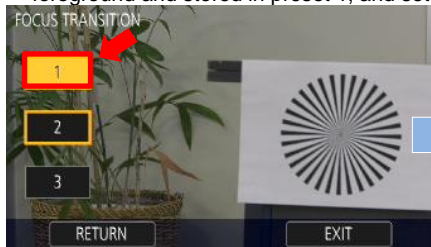

5. Press the USER button ("FOCUS TRANS" is assigned) and press preset number buttons (1 to 3) to recall the presets.

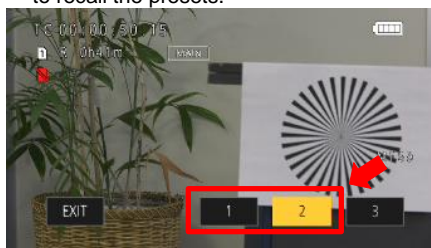

Focus transition feature will be canceled with following operations.

- Power OFF
- Switched to thumbnail mode
- Zooming

# 4. Understanding advanced features

## 4-8. Understanding Remote operation via AG ROP iPad app UX180 UX90

Remote control via Wi-Fi network is available by using an application for iPad.



### Necessary equipment

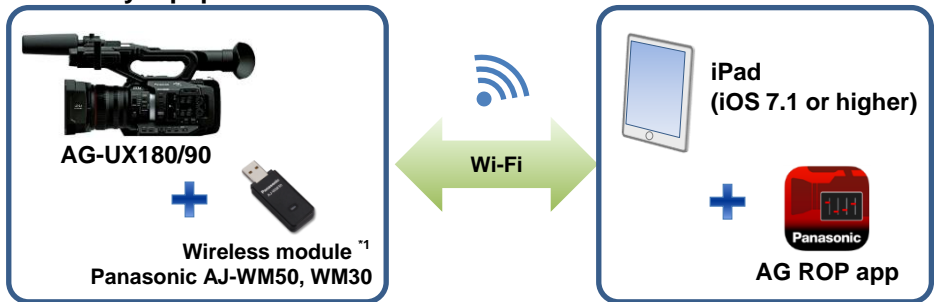

\*1 Contact your dealer for availability of the wireless modules.

### Setting up equipment (overview)

1. Install the Panasonic AG ROP app from App Store to the iPad.
2. Connect the Wi-Fi adaptor to an USB3.0 HOST port of the camera.
3. Set Wi-Fi related settings on the camera and the iPad. *See next page for the details.*
4. Connect the iPad to the camera.
5. Open Panasonic AG ROP.

# 4. Understanding advanced features

## Setup example:

### Settings on the Camera side



1. Set following USB related menu items to enable the USB3.0 port for AG ROP connection.

MENU > OTHER FUNCTIONS > USB MODE SELECT > **HOST**  
MENU > OTHER FUNCTIONS > USB MODE > **ON**



2. Set network related menu items (MENU > NETWORK SETUP > ) below.

Menu		Value
WIRELESS SETUP		Choose " <b>DIRECT</b> " and set followings SSID: Enter SSID name (Default: UX180, UX90) BAND: Choose " <b>2.4GHz</b> " or " <b>5GHz</b> " depends on Wi-Fi adaptor type. CHANNEL(2.4GH): Choose " <b>AUTO</b> " CHANNEL(5GH): Choose " <b>AUTO</b> " Password: (Default: <b>01234567890123456789abcdef</b> )
Wireless LAN Setup	IP address	(Default: <b>192.168.0.1</b> )
	Subnet mask	(Default: <b>255.255.255.0</b> )
	Gateway	(Default: <b>192.168.0.254</b> )
	DHCP	Choose " <b>SERVER</b> "

### Settings on iPad

1. Install the Panasonic AG ROP app from App Store.
2. Open "Settings  > Wi-Fi > ", and choose an SSID of the camera (example: UX180) to be connected.
3. Enter connection password (factory default: 01234567890123456789abcdef) to connect to the camera via Wi-Fi network.
4. Open the AG ROP app and confirm that the connection status on the camera is shown as  (ready to be controlled from the app).
5. Operate the camera from the AG ROP app.

### Connection status on the camera

	No connection
	Connected to a wireless LAN device (iPad, router etc.)
	Connected to a wireless LAN device and under controlled from AG ROP app

\* App Store is a service mark of Apple Inc.

\* Apple, the Apple logo, and iPad are trademarks of Apple Inc., registered in the U.S. and other countries.

# 5. Understanding scene file operations



# 5. Understanding scene file operations

The following six different scene presets come standard with the camera, and can be user customized if required.

## 5-1. SCENE FILE presets

F1:	Basic setting
F2: FLUO	Suitable for recording where the characteristics of fluorescent lamps are taken into consideration (example: shooting indoors). Most of the parameters are equal to "F1:" but the MATRIX is adjusted for fluorescent lighting. This is not particularly necessary under the fluorescent lighting close to natural light color temperature. But it is suitable for recording conditions where the color reproduction is poor due to blue-intense fluorescent lamps.
F3: SPARK	Suitable for recording with richer color level and sharper contrast. The picture will be showy with vivid colors and give a bright impression.
F4: STILL	Suitable for digital still camera-like recording.
F5: CINE V	Suitable for movie-like recording where importance is placed on contrast. This has a Gamma curve that makes a movie-like picture using a video camera.
F6: CINE D	Suitable for movie-like recording where importance is placed on the Dynamic Range. This Gamma gives priority to the Dynamic (D) Range and maintains the gradation that ranges evenly from low to high level. If the post-production editing or a kinescope is planned, this can be selected because recording in this mode will make such post-processing easier and smoother. Also, it will create a unique atmosphere which can sometimes be used as an effect.

## 5-2. Factory default settings

Item	F1:	F2: FLUO	F3: SPARK	F4: STILL	F5: CINE V	F6: CINE D
MASTER DETAIL	0	0	+6	+6	-8	-8
DETAIL CORING	1	1	1	1	1	1
SKIN TONE DETAIL	OFF	OFF	OFF	OFF	OFF	OFF
V DETAIL LEVEL	0	0	0	0	0	0
CHROMA LEVEL	0	0	+4	+4	-10	-10
CHROMA PHASE	0	0	+5	+5	0	0
MATRIX	NORM1	FLUO	NORM2	STILL-LIKE	CINELIKE	CINELIKE
MASTER PED	0	0	0	0	0	0
GAMMA MODE	HD	HD	HD	STILL-LIKE	C.LIKE V	C.LIKE D
BLACK GAMMA	0	0	-3	-3	0	0
KNEEMASTER POINT	93.0	93.0	93.0	93.0	93.0	93.0
KNEEMASTER SLOPE	85	85	85	85	85	85
DRS EFFECT	1	1	1	1	1	1

\* Setting values of each scene file can be overwritten as you like and saved.

# 5. Understanding scene file operations

## 5-3. Expressing the texture of objects (detail enhancement)

When expressing the outline or surface texture of an object, faint reflection of light may be intensified or, to the contrary, the picture may look blurred. This is a phenomenon caused by the strength / weakness of Detail signal to intensify the video signal for the object's outline. Adjustment of Detail signal can make the object's luster or texture look more natural.

MASTER DETAIL : +31 (UHD 3840x2160)



MASTER DETAIL : -31 (UHD 3840x2160)



# 5. Understanding scene file operations

## 5-4. Basic settings for Detail

MENU > SCENE FILE > (Factory default settings underlined)

**[MASTER DETAIL]** -31 - - - 0 - - - +31

Adjusts the level of overall Detail effect.

**[DETAIL CORING]** 0 - - - +1 - - - +60

Sets the level of signal (including noise) that suppresses the Detail effect.

**[SKIN TONE DTL]** ON / OFF

Sets the level of detail effect for a certain color (skin) tone.

**[V DETAIL LEVEL]** -7 - - - 0 - - - +7

Sets the intensity of Detail level in the vertical direction.

### Detail control

This is an outline signal which is added to a video signal.

If the Detail level is increased, the edges of video signal will be intensified and outlines in the picture will look sharper. If the Detail level is decreased, the edges of video signal will be weakened and the picture will look softer with its outline enhancement suppressed.

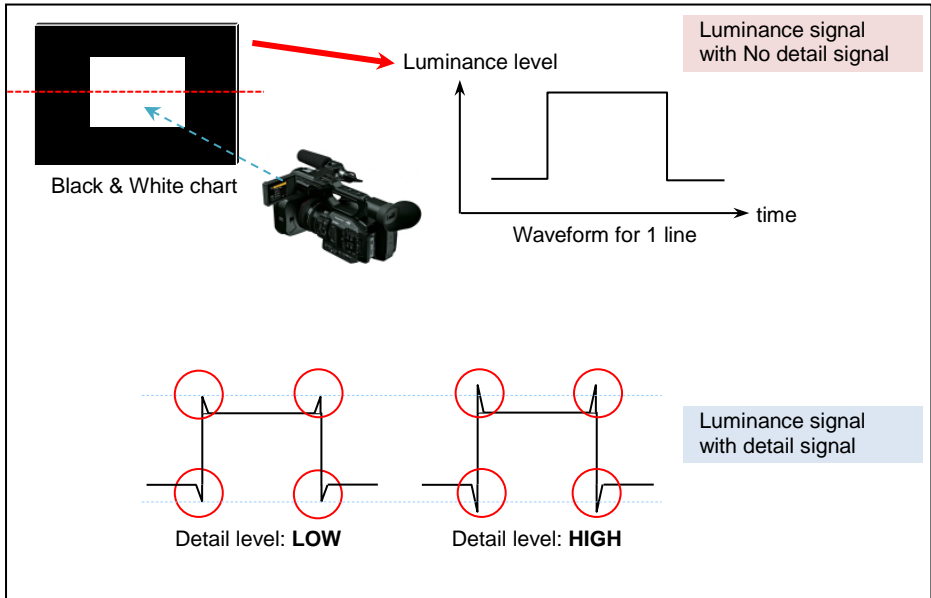

# 5. Understanding scene file operations

Effect comparison of detail control by changing MASTER DETAIL

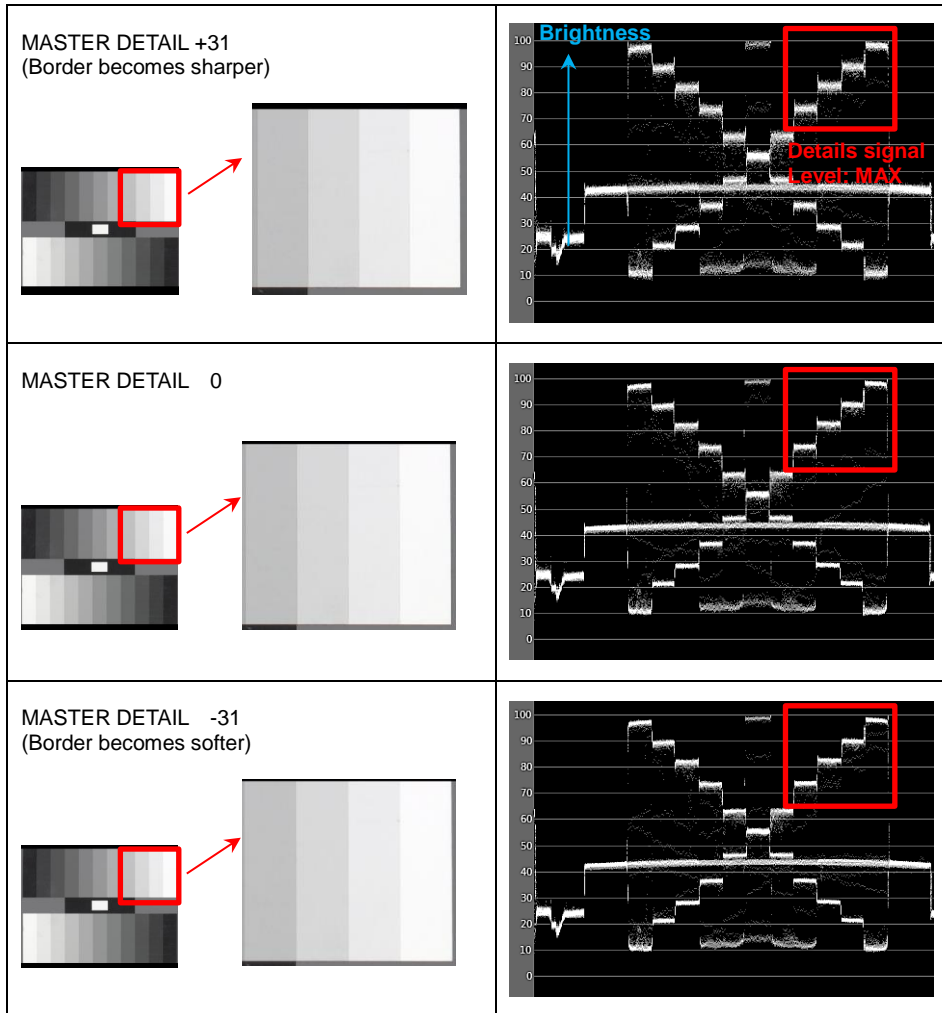



# 5. Understanding scene file operations

## Detail coring control

Outline compensation can be performed by adjusting the Detail, and enhanced outlines enable clear representation of images. But at the same time it may make the picture look coarse. This occurs because added Detail will also work on low-level signals which include noise.

Detail coring function can adjust the range of added Detail signal but also helps to reduce the noise introduced by the Detail circuits.

Noise is a low-level signal. So, when Detail coring is set to a higher level than noise signals, the Detail signal will work only on higher-brightness signals, and not on the noise.

By using this control, the outline of an object can be enhanced and its texture will look the same while the effects of increased image coarseness are suppressed.

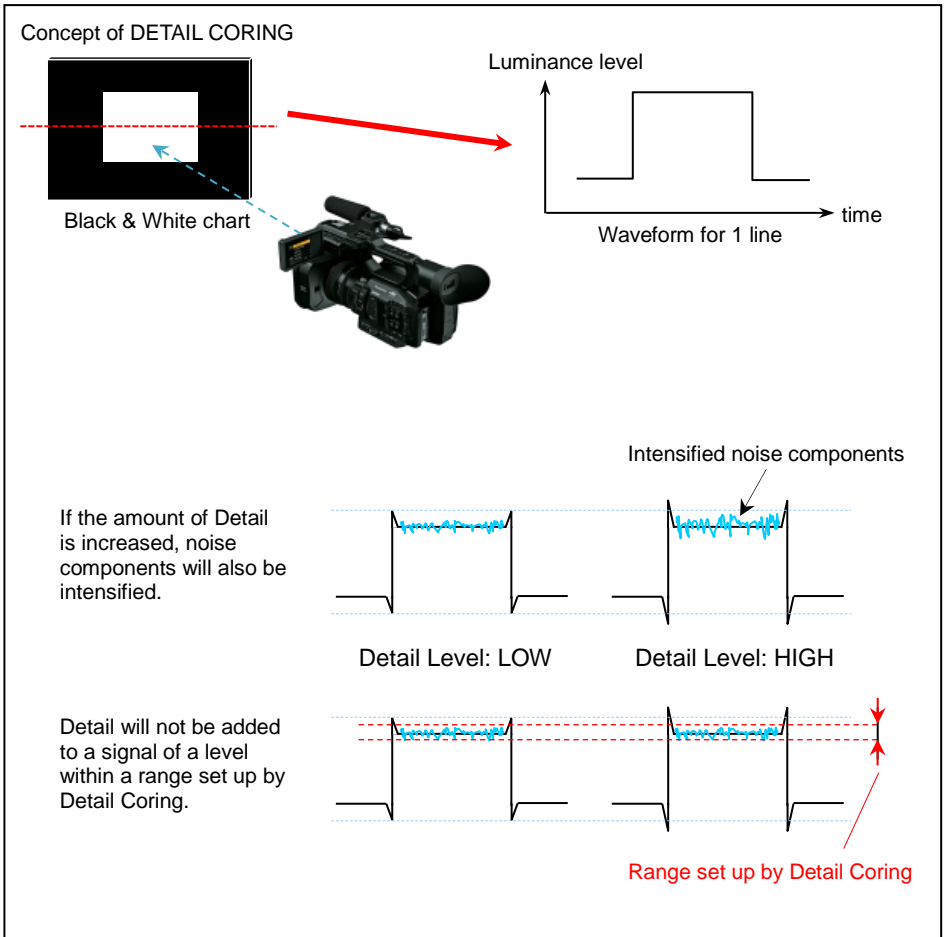

# 5. Understanding scene file operations

## 5-5. Expressing the gradation of a picture (Knee, Gamma)

Due to bright sunny weather or lighting, "blown-out highlights" can sometimes occur, where bright areas look completely white. This is a phenomenon caused by the luminance signals that are out of the camera's Dynamic Range (processing range). In order to put such high-brightness input signals within the Dynamic Range, Knee function can be used to compress the gradation.

MENU > SCENE FILE > (Factory default settings underlined)

**[KNEE MODE]** AUTO / MANUAL / OFF

AUTO: Adjusts master point and slope automatically.

MANUAL: Knee master point and slope can be adjusted manually.

OFF: Do not use Knee controls.

**[KNEE MASTER POINT]** 80.0 --- 93.0 --- 107.0

Sets the position of Knee Point. (\* Enabled when KNEE MODE is MANUAL)

**[KNEE MASTER SLOPE]** 0 --- 85 --- 99

Sets the slope of Knee. (\* Enabled when KNEE MODE is MANUAL)

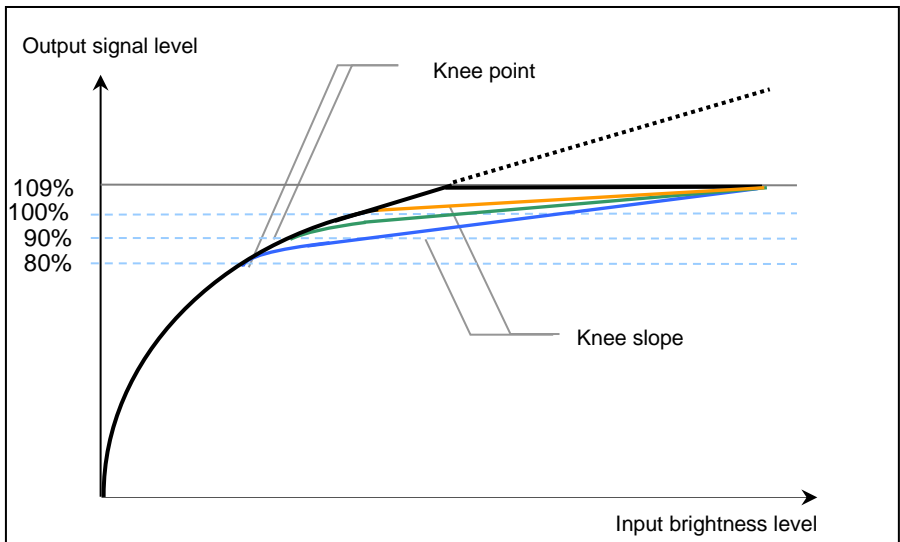

This is for explanation purposes only and may be different from actual measurements.

# 5. Understanding scene file operations

KNEE MASTER POINT: 107%

Highlight areas tend to be overexposed (no gradations visible) when value is increased.



KNEE MASTER POINT: 93.0%



KNEE MASTER POINT: 80.0%

Gradations in the highlight areas become visible when value is decreased.



# 5. Understanding scene file operations

## Gamma settings

There are cases where the color and contrast, which look natural to the eye, are not fully reproduced in the captured image. An effective way to improve the gradation of the output signal is to select a suitable Gamma curve according to the scene conditions. The AG-UX series offers eight types of different Gamma curves.

**HD:**

This is a video Gamma characteristic for HD (High Definition).

This Gamma complies with the standards defined by ARIB, EBU, SMPTE, etc. Use this for the purpose of normal HD shooting.

**SD:**

Gain is increased for dark areas more than HD Gamma.

This Gamma curve can be used for shooting in SD mode, or for HD shooting that needs the same Gamma as used in SD shooting.

**FILMLIKE 1:**

Compared with HD Gamma, this has the characteristics by which the gradation of the highlights can be reproduced better. Using this Gamma curve which gently slopes for the low-brightness area makes the picture look calm. Contrast becomes sharper and the gradation expression of the middle- and high-brightness areas (face, etc.) is extended.

**FILMLIKE 2:**

Compared with FILM LIKE 1, this has the characteristics by which the gradation of the highlights can be reproduced better.

**FILMLIKE 3:**

Compared with FILM LIKE 2, this has the characteristics by which the gradation of the highlights can be reproduced better.

**CINE-LIKE V:**

Video-use cine Gamma characteristics.

This is a Gamma curve to make a movie-like picture using a video camera. It creates a picture where more importance is placed on contrast than in normal video mode recording.

**CINE-LIKE D:**

Film-use cine Gamma characteristics.

This Gamma gives priority to the Dynamic Range and maintains the gradation that ranges evenly from low to high level. It creates a unique look which is sometimes used as an artistic effect.

**STILL-LIKE:**

This is a Gamma curve to make digital still camera-like picture using a video camera.

# 5. Understanding scene file operations

HD



SD



FILMLIKE1



FILMLIKE2



FILMLIKE3



STILL-LIKE



CINELIKE-V



CINELIKE-D



## 5. Understanding scene file operations

### Image comparison with different Gamma curves 1/4

HD



SD



## 5. Understanding scene file operations

### Image comparison with different Gamma curves 2/4

FILMLIKE1



FILMLIKE2



## 5. Understanding scene file operations

### Image comparison with different Gamma curves 3/4

FILMLIKE3



STILL-LIKE





## 5. Understanding scene file operations

### Image comparison with different Gamma curves 4/4

CINE-LIKE V



CINE-LIKE D



# 5. Understanding scene file operations

## Black gamma control

Dark parts of the image can be lifted or suppressed with this control.

MENU > SCENE FILE > (Factory default settings underlined)

**[BLACK GAMMA] -8 - - - 0 - - - +8**

Sets gamma characteristic for dark part of the image.

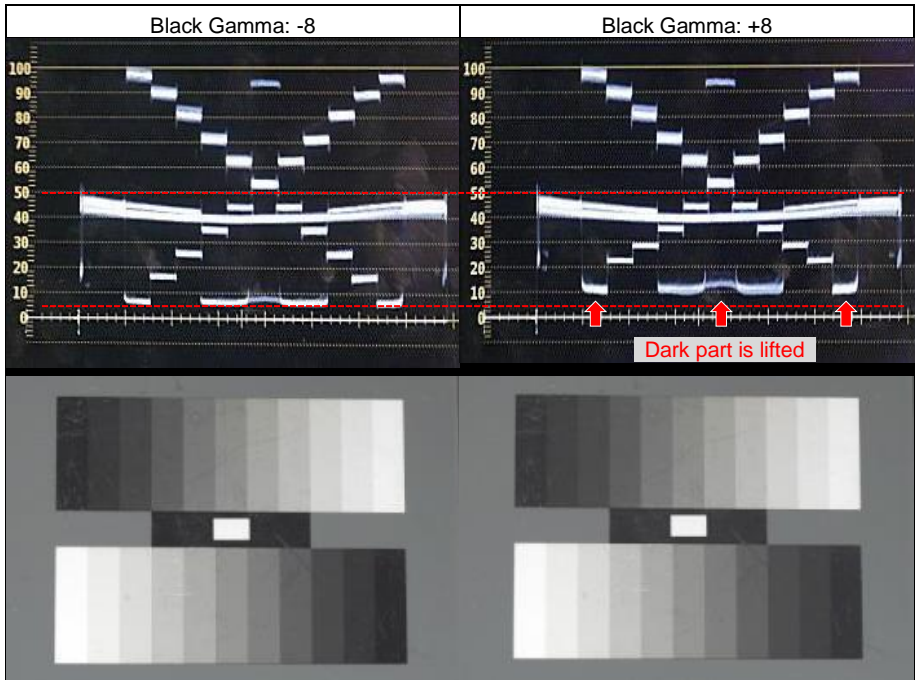

# 6. After recording



# 6. After recording

## 6-1. Connecting to PC/Mac

Recorded clips can be transferred rapidly between PC/Mac over USB3.0 interface.

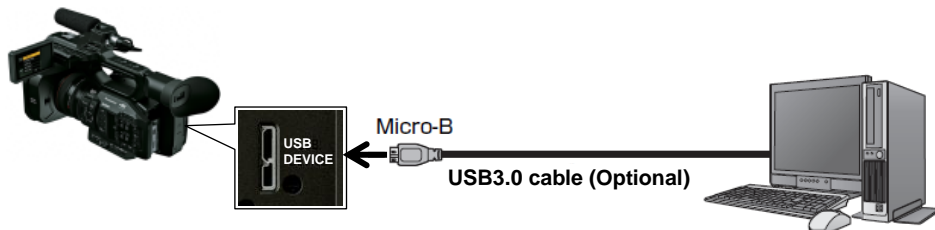

How to connect

1. Turn ON the power of the AG-UX camera.
2. Set MENU > OTHER FUNCTIONS > USB MODE : ON
3. Set MENU > OTHER FUNCTIONS > USB MODE SELECT: DEVICE
4. Connect a USB3.0 cable between the camera (USB DEVICE terminal) and PC/Mac.
5. Tap "PC" on the touch screen to connect.

- \* The built-in LCD panel will turn OFF for 5 seconds straight after connection is established when battery powered (the LCD panel works again when tapped).
- \* Data cannot be written from PC/Mac to the mounted SD card.

## 6-2. File structure of SD memory card

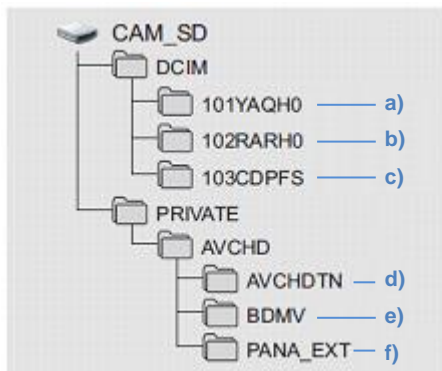

Files stored:

- a) Video clips in MOV format.
- b) Video clips in MP4 format.
- c) Still pictures captured from videos with the AG-UX series
- d) Thumbnails (AVCHD clips)
- e) AVCHD video clips (.MTS format)
- f) For file management only

\* Several kind of different files are stored under PRIVATE folder for AVCHD clips. Always copy the PRIVATE folder as a file set. Copying \*.MTS files only may cause clip to be unplayable.

# 6. After recording

## 6-3. Folder name structure for MOV/MP4 folders

Following information determines the folder names that stores clips in MOV/MP4 formats.

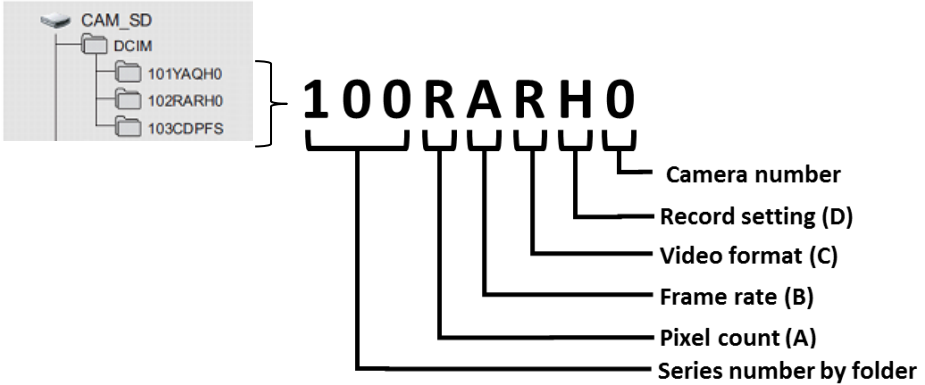

### Example: When a folder is named as "100RARH0"

The folder contains following video clips.

- Pixel count: "3840x2160"
- Frame rate: "59.94fps"
- Record format: MP4 LPCM progressive

(A) Pixel count	(B) Framerate (fps)	(C) Video format	(D) Record setting	Camera number
Y: 1920 x 1080 R: 3840 x 2160 Q: 4096 x 2160	A: 59.94 B: 50 C: 29.97 D: 25 E: 24.00 F: 23.98	J:Interlace (MOV, LPCM) K:Interlace (MP4, LPCM) Q:Progressive (MOV, LPCM) R:Progressive (MP4, LPCM)	D:Sub recording at 50Mbps E:Sub recording at 8Mbps P:Main recording H:Others	0 to 9:Camera No. is set from 0 to 9 A to G:Camera No. is set from 10 to 16

### What is the camera number?

This is to allow users to identify the camera by looking at recorded folders. Any number from **0** to **16** can be set with the following menu item.

MENU > SYSTEM MODE > CAMERA NUMBER SET: **0** to **16**

# 7. Appendix



# 7. Appendix

## 7-1. Recording time in each video setting

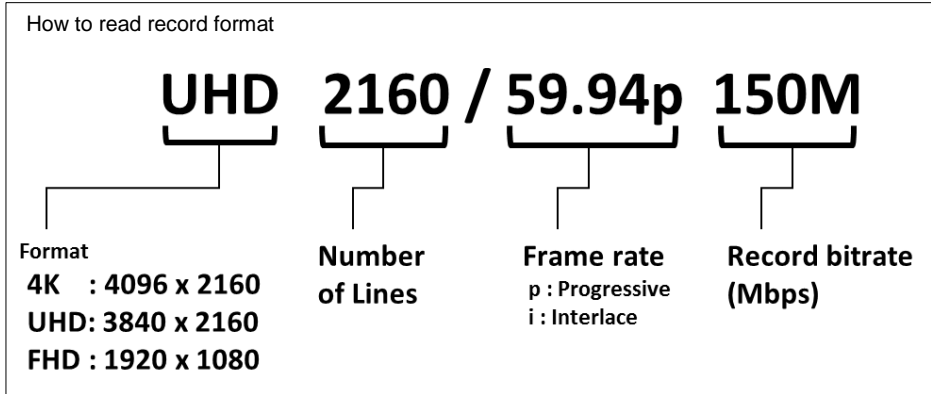

### MP4, MOV format (AG-UX180)

Record format	System frequency	Memory card capacity	
		16GB	64GB
4K 2160/24.00p 100Mbps	59.94Hz	20min	1h 20m
UHD 2160/59.94p 150Mbps		----	55min
UHD 2160/29.97p 100Mbps		20min	1h 20m
UHD 2160/23.98p 100Mbps		20min	1h 20m
FHD 1080/59.94p All-I 200Mbps		10min	40min
FHD 1080/59.94p 100Mbps		20min	1h 20m
FHD 1080/59.94p 50Mbps		40min	2h 40m
FHD 1080/29.97p All-I 200Mbps		10min	40min
FHD 1080/23.98p All-I 200Mbps		10min	40min
FHD 1080/29.97p 50Mbps		40min	2h 40m
FHD 1080/23.98p 50Mbps		40min	2h 40m
FHD 1080/59.94i 50Mbps		40min	2h 40m
UHD 2160/50.00p 150Mbps	50.00Hz	----	55min
UHD 2160/25.00p 100Mbps		20min	1h 20m
FHD 1080/50.00p All-I 200Mbps		10min	40min
FHD 1080/50.00p 100Mbps		20min	1h 20m
FHD 1080/50.00p 50Mbps		40min	2h 40m
FHD 1080/25.00p All-I 200Mbps		10min	40min
FHD 1080/25.00p 50Mbps		40min	2h 40m
FHD 1080/50.00i 50Mbps		40min	2h 40m

# 7. Appendix

## 7-1. Recording time in each video setting (continued)

### AVCHD (AG-UX180)

Record format	System frequency	Memory card capacity	
		16GB	64GB
PS 1080/59.94p	59.94Hz	1h 20m	5h 20m
PH 1080/59.94i		1h 30m	6h 00m
PH 1080/23.98p		1h 30m	6h 00m
HA 1080/59.94i		2h 00m	8h 30m
HE 1080/59.94i		6h 40m	27h 30m
PM 720/59.94p		4h 15m	17h 10m
SA 480/59.94i		4h 00m	16h 30m
PS 1080/50.00p	50.00Hz	1h 20m	5h 20m
PH 1080/50.00i		1h 30m	6h 00m
HA 1080/50.00i		2h 00m	8h 30m
HE 1080/50.00i		6h 40m	27h 30m
PM 720/50.00p		4h 15m	17h 10m
SA 576/50.00i		4h 00m	16h 30m



# 7. Appendix

## 7-1. Recording time in each video setting (continued)

### MP4, MOV format (AG-UX90: 59.94Hz model)

Record format			Memory card capacity	
			16GB	64GB
UHD	2160/59.94p	150Mbps	----	55min
UHD	2160/29.97p	100Mbps	20min	1h 20m
UHD	2160/23.98p	100Mbps	20min	1h 20m
FHD	1080/59.94p	All-I 200Mbps	10min	40min
FHD	1080/59.94p	100Mbps	20min	1h 20m
FHD	1080/59.94p	50Mbps	40min	2h 40m
FHD	1080/29.97p	All-I 200Mbps	10min	40min
FHD	1080/23.98p	All-I 200Mbps	10min	40min
FHD	1080/29.97p	50Mbps	40min	2h 40m
FHD	1080/23.98p	50Mbps	40min	2h 40m
FHD	1080/59.94i	50Mbps	40min	2h 40m

### AVCHD (AG-UX90: 59.94Hz model)

Record format			Memory card capacity	
			16GB	64GB
PS	1080/59.94p		1h 20m	5h 20m
PH	1080/59.94i		1h 30m	6h 00m
PH	1080/23.98p		1h 30m	6h 00m
HA	1080/59.94i		2h 00m	8h 30m
HE	1080/59.94i		6h 40m	27h 30m
PM	720/59.94p		4h 15m	17h 10m
SA	480/59.94i		4h 00m	16h 30m

# 7. Appendix

## 7-2. Output signal formats

<b>1. AG-UX180 System frequency: 59.94Hz</b>				
REC format	Resolution setting	HDMI OUT	SDI OUT	AV OUT
<b>4K 24.00p</b>	SYSTEM	2160/24.00p	--	--
	1080p	1080/24.00p	1080/24.00PsF	--
<b>UHD 59.94p</b>	SYSTEM	2160/59.94p <sup>*1</sup>	1080/59.94p	--
	1080p	1080/59.94p	1080/59.94p	--
	1080i	1080/59.94i	1080/59.94i	--
	DOWN CONVERT	480/59.94p	480/59.94i	480/59.94i
<b>UHD 29.97p</b>	SYSTEM	2160/29.97p	1080/29.97PsF	--
	1080p	1080/59.94p	1080/59.94p	--
	1080i	1080/59.94i	1080/59.94i	--
	DOWN CONVERT	480/59.94p	480/59.94i	480/59.94i
<b>UHD 23.98p</b>	SYSTEM	2160/23.98p	1080/23.98PsF	--
	1080p	1080/59.94p	1080/59.94p	--
	1080i	1080/59.94i	1080/59.94i	--
	DOWN CONVERT	480/59.94p	480/59.94i	480/59.94i
<b>FHD 59.94p PS 59.94p</b>	SYSTEM	1080/59.94p	1080/59.94p	--
	1080p	1080/59.94p	1080/59.94p	--
	1080i	1080/59.94i	1080/59.94i	--
	DOWN CONVERT	480/59.94p	480/59.94i	480/59.94i
<b>FHD 59.94i PH 59.94i HA 59.94i HE 59.94i</b>	SYSTEM	1080/59.94i	1080/59.94i	--
	1080p	1080/59.94p	1080/59.94p	--
	1080i	1080/59.94i	1080/59.94i	--
	DOWN CONVERT	480/59.94p	480/59.94i	480/59.94i
<b>FHD 29.97p</b>	SYSTEM	1080/29.97p	1080/29.97PsF	--
	1080p	1080/59.94p	1080/59.94p	--
	1080i	1080/59.94i	1080/59.94i	--
	DOWN CONVERT	480/59.94p	480/59.94i	480/59.94i
<b>FHD 23.98p PH 23.98p</b>	SYSTEM	1080/23.98p	1080/23.98PsF	--
	1080p	1080/59.94p	1080/59.94p	--
	1080i	1080/59.94i	1080/59.94i	--
	DOWN CONVERT	480/59.94p	480/59.94i	480/59.94i
<b>PM 720p</b>	SYSTEM	720/59.94p	720/59.94p	--
	1080p	1080/59.94p	1080/59.94p	--
	1080i	1080/59.94i	1080/59.94i	--
	DOWN CONVERT	480/59.94p	480/59.94i	480/59.94i
<b>SA 480i</b>	SYSTEM	480/59.94p	480/59.94i	480/59.94i

\*1. Output format 4:2:0 8bit, 2160/59.94p and becomes 4:2:2 8bit, 1080/59.94p while in record mode.

# 7. Appendix

## 7-2. Output signal formats (continued)

<b>2. AG-UX180 System frequency: 50.00Hz</b>				
REC format	Resolution setting	HDMI OUT	SDI OUT	AV OUT
<b>4K 24.00p</b>	SYSTEM	2160/24.00p	--	--
	1080p	1080/24.00p	1080/24.00PsF	--
<b>UHD 50.00p</b>	SYSTEM	2160/50.00p <sup>*2</sup>	1080/50.00p	--
	1080p	1080/50.00p	1080/50.00p	--
	1080i	1080/50.00i	1080/50.00i	--
	DOWN CONVERT	576/50.00p	576/50.00i	576/50.00i
<b>UHD 25.00p</b>	SYSTEM	2160/25.00p	1080/25.00PsF	--
	1080p	1080/50.00p	1080/50.00p	--
	1080i	1080/50.00i	1080/50.00i	--
	DOWN CONVERT	576/50.00p	576/50.00i	576/50.00i
<b>FHD 50.00p PS 50.00p</b>	SYSTEM	1080/50.00p	1080/50.00p	--
	1080p	1080/50.00p	1080/50.00p	--
	1080i	1080/50.00i	1080/50.00i	--
	DOWN CONVERT	576/50.00p	576/50.00i	576/50.00i
<b>FHD 50.00i PH 50.00i HA 50.00i HE 50.00i</b>	SYSTEM	1080/50.00i	1080/50.00i	--
	1080p	1080/50.00p	1080/50.00p	--
	1080i	1080/50.00i	1080/50.00i	--
	DOWN CONVERT	576/50.00p	576/50.00i	576/50.00i
<b>FHD 25.00p</b>	SYSTEM	1080/25.00p	1080/25.00PsF	--
	1080p	1080/50.00p	1080/50.00p	--
	1080i	1080/50.00i	1080/50.00i	--
	DOWN CONVERT	576/50.00p	576/50.00i	576/50.00i
<b>PM 25.00p</b>	SYSTEM	720/50.00p	720/50.00p	--
	1080p	1080/50.00p	1080/50.00p	--
	1080i	1080/50.00i	1080/50.00i	--
	DOWN CONVERT	576/50.00p	576/50.00i	576/50.00i
<b>SA 576i</b>	SYSTEM	576/50.00p	576/50.00i	576/50.00i

\*2. Output format 4:2:0 8bit, 2160/50.00p and becomes 4:2:2 8bit, 1080/50.00p while in record mode.

# 7. Appendix

## 7-2. Output signal formats (continued)





<b>3. AG-UX90 System frequency: 59.94Hz</b>			
<b>REC format</b>	<b>Resolution setting</b>	<b>HDMI OUT</b>	<b>VIDEO OUT</b>
<b>UHD 29.97p</b>	SYSTEM	2160/29.97p	--
	1080p	1080/59.94p	--
	1080i	1080/59.94i	--
	DOWN CONVERT	480/59.94p	480/59.94i
<b>UHD 23.98p</b>	SYSTEM	2160/23.98p	--
	1080p	1080/59.94p	--
	1080i	1080/59.94i	--
	DOWN CONVERT	480/59.94p	480/59.94i
<b>FHD 59.94p PS 59.94p</b>	SYSTEM	1080/59.94p	--
	1080p	1080/59.94p	--
	1080i	1080/59.94i	--
	DOWN CONVERT	480/59.94p	480/59.94i
<b>FHD 59.94i PH 59.94i HA 59.94i HE 59.94i</b>	SYSTEM	1080/59.94i	--
	1080p	1080/59.94p	--
	1080i	1080/59.94i	--
	DOWN CONVERT	480/59.94p	480/59.94i
<b>FHD 29.97p</b>	SYSTEM	1080/29.97p	--
	1080p	1080/59.94p	--
	1080i	1080/59.94i	--
	DOWN CONVERT	480/59.94p	480/59.94i
<b>FHD 23.98p PH 23.98p</b>	SYSTEM	1080/23.98p	--
	1080p	1080/59.94p	--
	1080i	1080/59.94i	--
	DOWN CONVERT	480/59.94p	480/59.94i
<b>PM 720p</b>	SYSTEM	720/59.94p	--
	1080p	1080/59.94p	--
	1080i	1080/59.94i	--
	DOWN CONVERT	480/59.94p	480/59.94i
<b>SA 480i</b>	SYSTEM	480/59.94p	480/59.94i

# 7. Appendix

## 7-3. Genuine accessories

This page introduces accessories come standard with AG-UX180 and AG-UX90



Battery pack (5,900mAh)	AC adaptor	XLR connector cover
 <p>Part No. AG-VBR59</p>	 <p>Part No. SAE0011AE</p>	 <p>Part No. VJF1468 (1pc.)</p>
Battery charger		
 <p>Part No. SAB0002BA (for AG-UX180MC, UX90MC) Part No. SAB0002AB (for all AG-UX180/90 models except for MC models)</p>		



\* Part number and design are subject to change without notice.

# 7. Appendix

## Optional accessory

Battery pack (AG-VBR batteries support quick charging with AG-BRD50 quick charger)

			
<p><b>AG-VBR118G</b> (11,800mAh)</p>	<p><b>AG-VBR89G</b> (8,850mAh)</p>	<p><b>AG-VBR59</b> (5,900mAh)</p>	<p><b>VW-VBD58</b> (5,800mAh)</p>

Battery charger	Microphone	LED light
		
<p><b>AG-BRD50</b> (Support quick charging with AG-VBR batteries)</p>	<p><b>AG-B23</b> (AC cord comes standard)</p>	<p><b>VW-LED1</b> (Work with 4x AA batteries)</p>

Wi-Fi module		SD memory card	
		 <p><b>UHS-I</b>  <b>CLASS 10</b></p> <p>128GB   </p> <p>Read max.95MB/s Write max.90MB/s</p>	 <p><b>UHS-I</b>  <b>CLASS 10</b></p> <p>64GB   </p> <p>Read max.95MB/s Write max.90MB/s</p>
<p><b>AJ-WM50 *</b> (5G/2.4GHz bands)</p>	<p><b>AJ-WM30 *</b> (2.4GHz band)</p>	<p><b>RP-SDUE12DVX</b> (128GB)</p>	<p><b>RP-SDUE64DVX</b> (64GB)</p>

Part number and design are subject to change without notice.

\* May Not be available in some countries/regions..

## Revision history

Issued	Revision history	Document ver.
Dec.2016	First edition issued	v1.00E

# Panasonic

Panasonic Corporation

Download firmware, check frequently asked questions at  
[https://panasonic.biz/cns/sav/pass\\_e](https://panasonic.biz/cns/sav/pass_e)