

Canon

LENS ACCESSORY

镜头配件

FPD-400D

FOCUS DEMAND

电动聚焦控制器

FPM-420D

FOCUS POSITIONAL SERVO MODULE

电动聚焦位置伺服模块

取 扱 説 明 書

OPERATION MANUAL

使 用 説 明 書

ご使用の前に必ずこの取扱説明書をお読みください。

なお、取扱説明書は必要に応じてご覧になれるように大切に保管してください。

Read this operation manual before using the product.

Keep the manual in place for future reference.

在使用本产品之前，请务必先仔细阅读本使用说明书。

请务必妥善保管好本书，以便日后能随时查阅。

请在充分理解内容的基础上，正确使用。

J/E/C



ENGLISH VERSION



FCC REGULATIONS

This device complies with Part 15B of the FCC Rules. Operation is subject to the following two conditions: (1) This device may not cause harmful interference, and (2) this device must accept any interference received, including interference that may cause undesired operation.

Note: This equipment has been tested and found to comply with the limits for a Class A digital device, pursuant to Part 15B of the FCC Rules.

These limits are designed to provide reasonable protection against harmful interference when the equipment is operated in a commercial environment. This equipment generates, uses, and can radiate radio frequency energy and, if not installed and used in accordance with the instruction manual, may cause harmful interference to radio communications. Operation of this equipment in a residential area is likely to cause harmful interference in which case the user will be required to correct the interference at his own expense.

Do not make any changes or modifications to the equipment unless otherwise specified in the manual. If such changes or modifications should be made, you could be required to stop operation of the equipment.

Canadian Radio Interference Regulations

This Class A digital apparatus meets all requirements of the Canadian Interference-Causing Equipment Regulations.

Cet appareil numérique de la classe A respecte toutes les exigences du Règlement sur le matériel brouilleur du Canada.



We, Canon Inc., in Japan and Canon Europa N. V., in The Netherlands, confirm that the BCTV zoom lens accessory is conformity with the essential requirements of EC Directive(s) by applying the following standards:

EN55103-1, and EN55103-2

Note:

- a) Applicable Electromagnetic Environments:
E1 (residential), E2 (commercial and light industrial),
E3 (urban outdoors) and E4 (controlled EMC environment, ex. TV studio).
- b) Use of shielded cable is required to comply with limits specified by above standards.

Dieses Produkt ist zum Gebrauch im Wohnbereich, Geschäfts- und Gewerbebereich sowie in Kleinbetrieben vorgesehen.

INTRODUCTION

Thank you for purchasing Canon's TV Zoom Lens Accessories. These instructions explain the functions and operation of these accessories, and they outline the precautions to be heeded during the unit's operation. Before use, please read through and familiarize yourself with the instructions, and then keep them in a safe place for future reference.

GENERAL DESCRIPTION

These accessories are used to perform remote focus operations.

CONTENTS



	GENERAL SAFETY INFORMATION	20
§1.	CONFIGURATION.....	25
§2.	MOUNTING and CONNECTING.....	26
2-1.	For digital “R” type and “R” type lenses only.....	26
2-2.	For digital “A” type and “A” type lenses only	29
§3.	OPERATION.....	31
TECHNICAL DOCUMENTS: EXTERNAL VIEW AND GENERAL CIRCUIT DIAGRAM.....		
		51
INDEX		56

- MAJOR LENS TYPES EXPLAINED IN THIS MANUAL -

○ The classifications for the lens types explained in this manual are shown below.

The “R” type lenses require conversion cable CC-1220, and the “A” type lenses require conversion cable CC-0620 (both sold separately).

Lens models			
Type digital “R”	Type digital “A”	Type “R”	Type “A”
KRSD	KASD	KRS	KAS
IRSD	IASD	IRS	IAS
WRSD	WASD	WRS	WAS
VRSD	VASD	VRS	VAS





GENERAL SAFETY INFORMATION

The safety warnings and cautions provided on the product or in this operation manual must be observed. Failure to observe warnings and cautions provided to guard against hazards may result in injury or accident.

Read this operation manual carefully to familiarize yourself with its contents and ensure that you can operate the product properly.

Also, store this manual in a safe place where it can easily be referenced whenever required.

This operation manual uses the following symbols and terms to identify hazards to protect you and others by aiming to prevent the occurrence of accidents.

 WARNING	Indicates hazardous situations which, if not heeded, may result in death or serious injury to you or other persons.
 CAUTION	Indicates hazardous situations which, if not heeded, may result in minor or moderate injury to you or other persons, or damages to your property.
※ (NOTE)	Emphasizes essential information which, if not heeded, may render the product unworkable or cause it to function improperly. Also, provides helpful information for you operation.

HANDLING THE PRODUCT



CAUTION

1. Do not drop the product when transporting it or when attaching or detaching it to or from the camera head.
The product may fall, possibly causing injury.
2. Make sure all mountings are tightened securely. If any of these mountings becomes loose, the product may fall, possibly causing injury.
3. Inspect all mountings periodically (about every 6 months to 1 year) to make sure they are securely tightened, and tighten any loose portions.
Otherwise, the product may fall, possibly causing injury.
4. If it becomes necessary to repair this product, or to perform any operations or adjustments not mentioned in this operation manual, contact Canon's representative or the dealer who originally supplied the lens.

※ (NOTE)

1. Protect the product from strong impacts or shocks. Striking or dropping the lens may result in a malfunction.
2. This product is not completely waterproof, so avoid exposing it directly to rain or snow.
When the product must be used in rain or snow, provisions should be made to prevent the product from getting wet.
3. If the product is to be used in adverse environments, such as in a chemical laden atmosphere, consult with Canon's representative beforehand.

DEALING WITH ABNORMALITIES



WARNING

1. Should any of the abnormalities described below occur, immediately unplug the lens cable from the camera, and then contact Canon's representative or the dealer from whom you purchased the product.
 - Smoke, unusual smells or unusual noise
 - Entry of foreign objects (metals, liquids, etc.) inside the product

MAINTENANCE AND INSPECTION



WARNING

1. Unplug the lens cable and remove the lens from the camera, before attempting to clean the lens.
Never use flammable substances such as benzene or thinner for cleaning, as this may present a serious fire or electric shock hazard.

※ (NOTE)

1. Periodic inspection
A periodic inspection about once a year is recommended.
The inspection and maintenance interval depends on the operating conditions, the frequency of use, and the environment. If required, overhaul the lens.

STORAGE

※ (NOTE)

1. Moisture inside the product
If the product becomes damp because of use in fog, mist or drizzle, wipe off the moisture with a soft dry cloth and seal the product together with an efficient desiccant in a vinyl bag to remove moisture which has entered into the interior.

TO THE CUSTOMER

1. Canon shall bear no responsibility for damage resulting from improper operation of this product by the customer.
2. Canon shall make no guarantees about the product quality, functions, or operation manual and its marketability and suitability for the customer's purpose.
3. Canon shall make no guarantees about the results obtained using this product.
4. The product specifications, configuration, and appearance are subject to change without prior notice.
5. For further information on repairs, maintenance, or adjustments not mentioned in this operational manual, contact your Canon dealer or your Canon sales representative.
6. Note that Canon may be unable to undertake servicing or repair of a product if it is modified without consulting Canon or your Canon sales representative.

CANON INC.

30-2, Shimomaruko 3-chome, Ohta-ku, Tokyo 146-8501, Japan

CANON EUROPA N.V.

Bovenkerkerweg 59-61, 1185 XB Amstelveen, The Netherlands

All rights reserved. No part of this operation manual may be reproduced or copied in any form or by any means without the written permission of Canon Inc.

§1. CONFIGURATION

Make sure all of the following items are included in the packing box.

(If you find any item missing, please contact the dealer from whom you purchased this product.)

※ (NOTE) : This operation manual describes the operation of both the servo focus demand and focus positional servo module. The focus positional servo module is required when the servo focus demand is used with the digital “R” type and “R” type lenses. (The focus positional servo module is not necessary with the digital “A” type and “A” type lenses since a focus servo module is already built in.) Note that the focus characteristics curve selection function cannot be used with the built-in focus module of the “A” type lenses. Also, the product components below are grouped according to the respective mechanism. If you find any components missing, please contact the store where you purchased the product.

○ FPD-400D product components

UNIT	Q'TY
SERVO FOCUS DEMAND <FPD-400D>	1
CLAMPER <CR-10>	1
OPERATION MANUAL	1

○ FPM-420D product components

UNIT	Q'TY
FOCUS POSITIONAL SERVO MODULE <FPM-420D>	1
OPERATION MANUAL	1

※ (NOTE): Storing environment

Check the following points, and make sure the place where the lens is stored satisfies the following conditions.

1. Store the lens only under the following ambient conditions.
 Ambient temperature : -30°C to +60°C
 Ambient humidity : up to 60%RH (no condensation)
2. Do not subject the product to strong physical shock or vibration.

§2. MOUNTING and CONNECTING

2-1. For digital “R” type and “R” type lenses only

(A) Lens side preparation

Remove the zoom lever.

※(NOTE) : Be sure to keep the zoom lever in a safe place so as not to lose it.

(B) Mount the necessary accessories

1. To mount the clamber

Loosen the large and small fastening knobs of the clamber provided with the flexible zoom control unit.

Mount this unit onto panning rod of the tripod, and tighten both fastening knobs to secure the clamber.

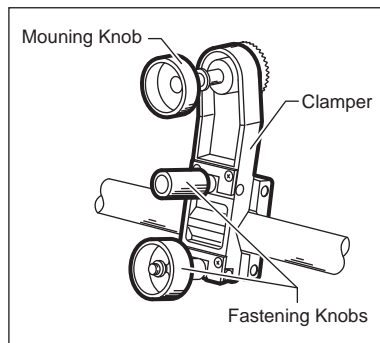

2. To mount the focus demand

Mate the rose joint of the focus demand with the rose joint of the clamber.

Then tighten them with the mounting knob of the clamber by turning clockwise.

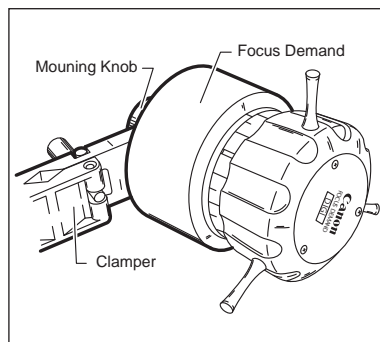

3. To mount the focus positional servo module

Attach the focus positional servo module on the lens by aligning the guide pin and screw of the mounting knob of the module to the guide hole and thread hole on the lens barrel respectively.

Tighten securely the module by turning the mounting knob clockwise.

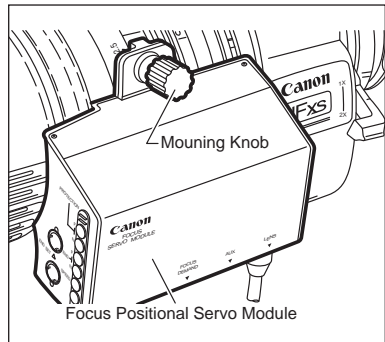

4. To connect the cables from the focus demand and focus positional servo module

Plug the cable from the focus demand to the preset box connector (20-pin focus demand) at the bottom of the focus positional servo module.

- Digital "R" type lens

Plug the cable from the focus servo module to the zoom remote and focus remote connector (20-pin) at the bottom of the lens drive unit.

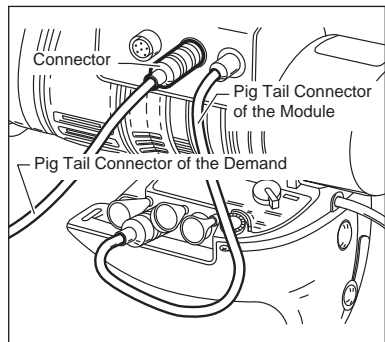

Digital "R" type

- "R" type lens

Plug the cable (20-pin) from the focus servo module to the preset box connector (12-pin) at the bottom of the lens drive unit by attaching a conversion connector CC-1220 (sold separately).

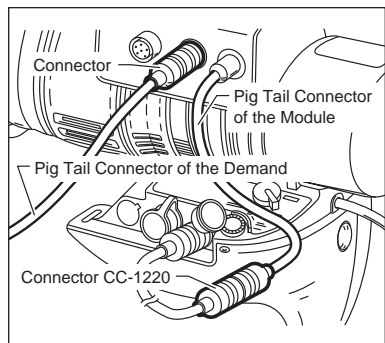

"R" type

(C) Focus servo module initial adjustment

Before put in use, the focus servo module must be adjusted according to the following procedure.

1. Potentiometer positional adjustment

The module contains a potentiometer which detects the focus position. After mounting the module on the lens, it is necessary to adjust the pot to determine the travel range by the following procedure.

By pressing button (1) end set switch, the focus ring rotates and stops at the mechanical end. But keep pressing another 2 to 3 seconds.

And then by pressing button (2) end set switch, the focus ring rotates and stops at the other mechanical end. But keep pressing another 2 to 3 seconds.

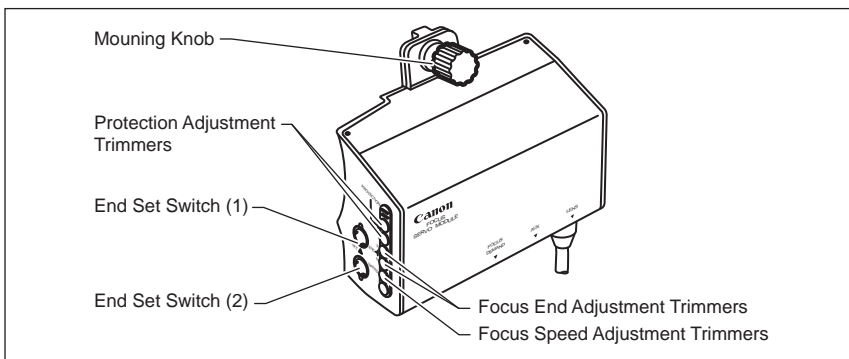

Now adjustment work is done.

※(NOTE) : In addition to the adjustment points described above, the focus servo module has following adjustment points: Protection adjustment trimmer, focus end adjustment trimmer, and focus speed adjustment trimmer. These points have been factory-adjusted properly. Any untrained person should not touch these trimmers. Unskilled workers may damage the equipment.

After the focus demand has been mounted, turn the operation knob of the focus demand, and make sure that the focus ring the lens barrel rotates smoothly.

2-2. For digital “A” type and “A” type lenses only

(A) Lens side preparation

Set the focus operation change-over knob at the bottom of the lens drive unit to “SERVO” position.

※ (NOTE) : For smooth change, turn the change-over knob while rotating the focus ring slightly.

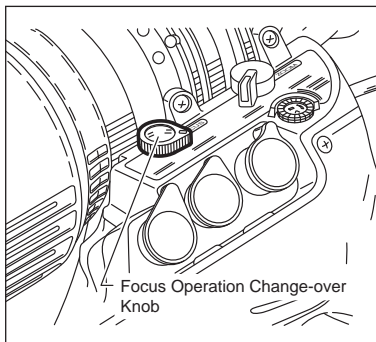

(B) Mount the necessary accessories

1. To mount the clamber

Loosen the large and small fastening knobs of the clamber provided with the flexible zoom control unit.

Mount this unit onto panning rod of the tripod, and tighten both fastening knobs to secure the clamber.

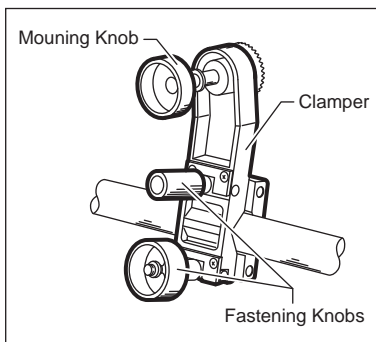

2. To mount the focus demand

Mate the rose joint of the focus demand with the rose joint of the clamber.

Then tighten them with the mounting knob of the clamber by turning clockwise.

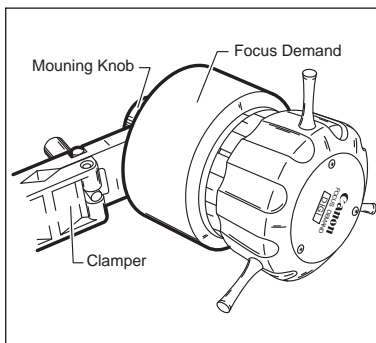

3. To connect the cable from the focus demand

• Digital “A” type lens

Plug the cable from the focus demand to the zoom remote and focus remote connector (20-pin) at the bottom of the lens drive unit.

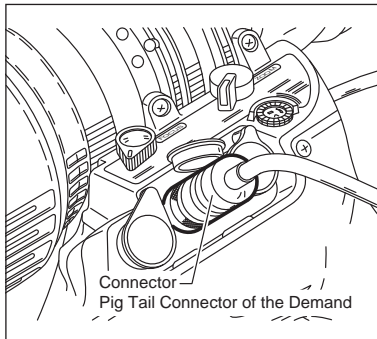

Digital “A” type

• “A” type lens

Plug the cable (20-pin) from the focus demand to the focus remote connector (6-pin) at the bottom of the lens drive unit by attaching a conversion connector CC-0620 (sold separately).

However, note that the focus characteristics curve selection function (described later) cannot be used.

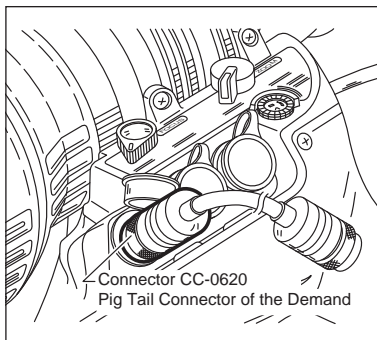

“A” type

※ (NOTE) : The focus characteristics curve selection function (described later) can be used for the “A” type lens if the lens is used in combination with the focus servo module FPM-420D and focus demand FPD-400D. Follow the connection procedure for the “R” type lens.

§3. OPERATION

The focus can be operated by turning the operation knob of the servo focus demand.

Turn the operation knob clockwise, as viewed from the operation knob, to focus the lens on a farther object.

Turn the operation knob counterclockwise, as viewed from the operation knob, to focus the lens on a closer object.

Full range from min. Object distance to infinity is covered by one turn (approx. 330 degrees) of the operation knob.

- To change the focus direction

The operation knob of the servo focus demand is factory set to focus the lens on farther object, by turning it clockwise.

However, this focus direction may be changed by switching the position of the reverse switch, located back plate of the servo focus demand.

- Focus characteristics curve selection

The focus characteristics curve selection switch on the focus demand can be used to select either line or curve modes for the focus movement characteristics.

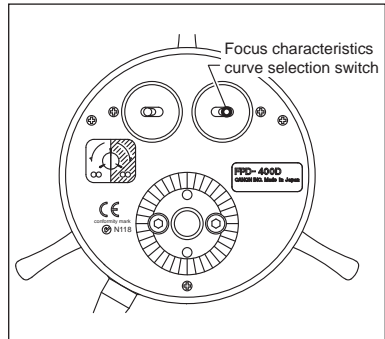
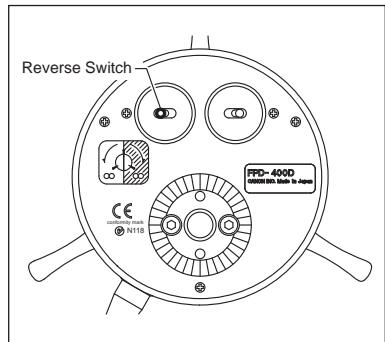
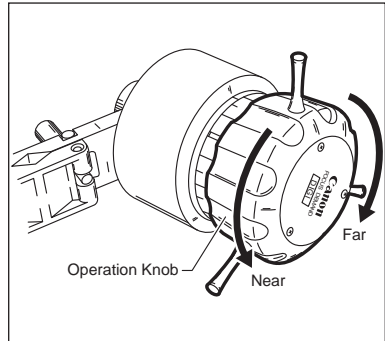

※(NOTE) : This operation cannot be used for “A” type lens when the focus demand FPD-400D is connected. (See §2. MOUNTING and CONNECTING.)
However, this operation can be used when the focus positional servo module is connected. Follow the connection procedure for the “R” type lens.

STANDARD Mode (switch at left side) : Standard characteristics where the focus lens group moves linearly when the knob is rotated.

FAR Mode (switch at right side) : Curve characteristics where the focus lens group exhibits less movement as it approaches the FAR end when the knob is rotated. This mode makes it easy to perform fine adjustment at the FAR end.

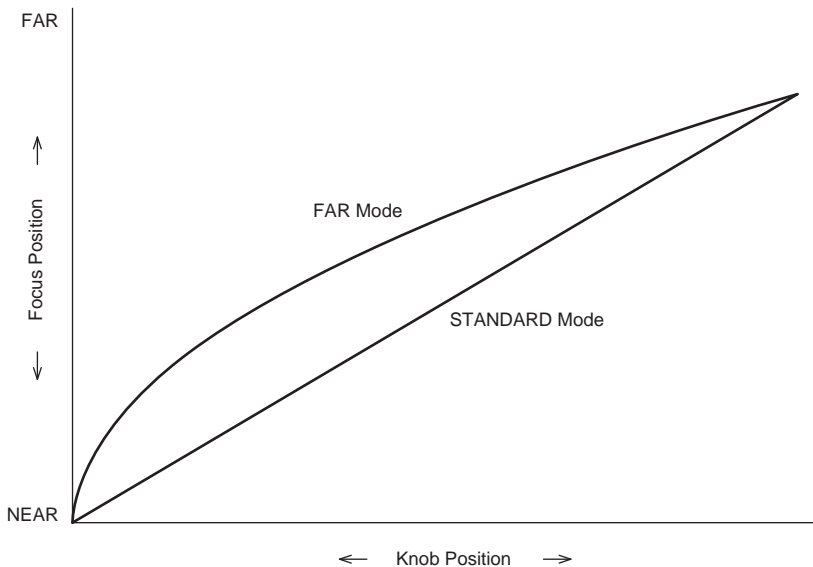

資料集



TECHNICAL DOCUMENTS



资料集

– 資料集の目次 –

§1. FPD-400D

(1) 外観図..... 52

(2) 総合結線図 53

§2. FPM-420D

(1) 外観図..... 54

(2) 総合結線図 55

– TABLE OF CONTENTS FOR
THE TECHNICAL DOCUMENTS –

§1. FPD-400D

(1) EXTERNAL VIEW 52

(2) GENERAL CIRCUIT DIAGRAM..... 53

§2. FPM-420D

(1) EXTERNAL VIEW 54

(2) GENERAL CIRCUIT DIAGRAM..... 55

– 资料集目录 –

§1. FPD-400D

(1) 外观图..... 52

(2) 综合接线图 53

§2. FPM-420D

(1) 外观图..... 54

(2) 综合接线图 55

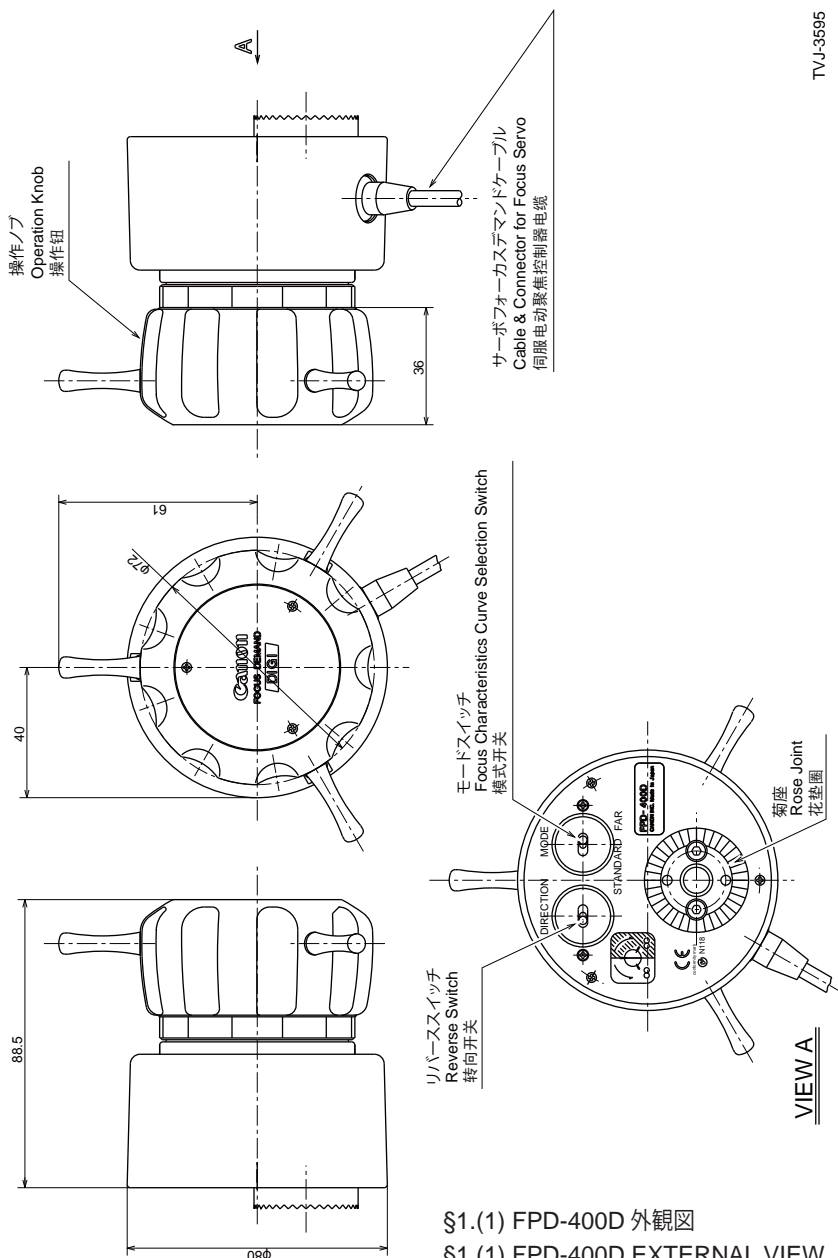

TVJ-3585

§1.(1) FPD-400D 外觀圖
 §1.(1) FPD-400D EXTERNAL VIEW
 §1.(1) FPD-400D 外观圖

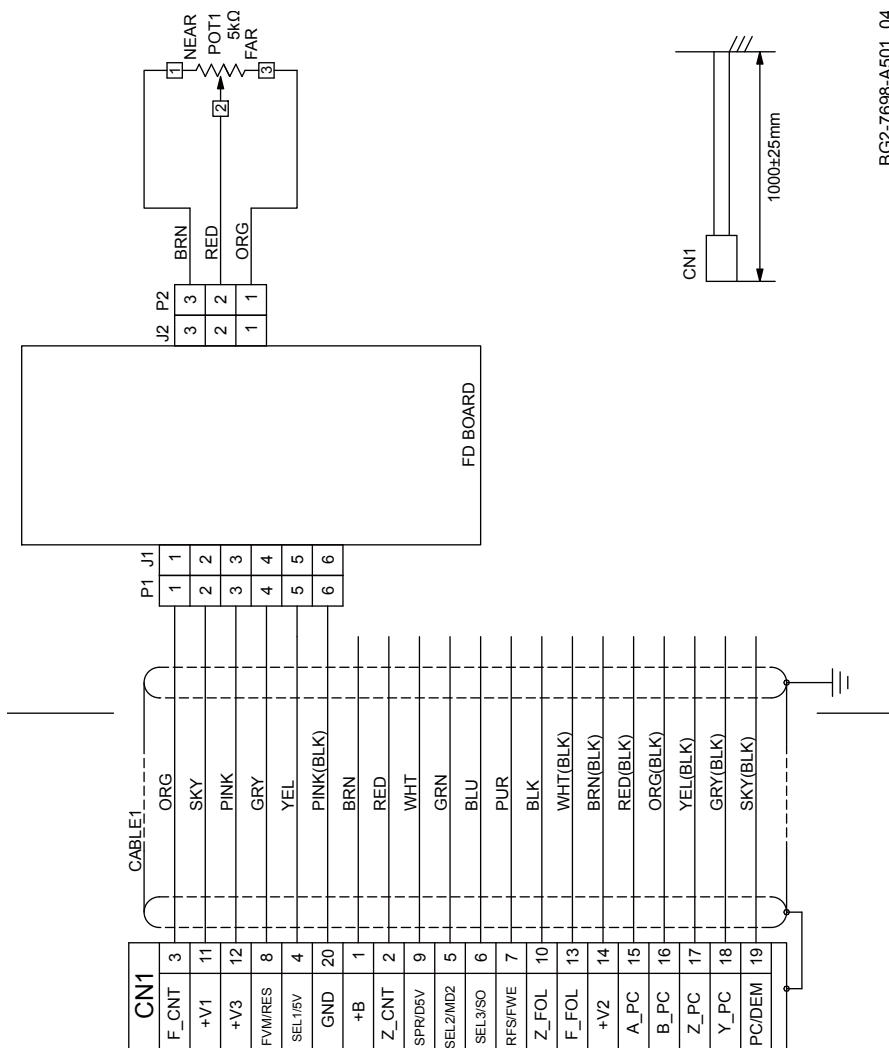

§1.(2) FPD-400D 綜合結線圖

§1.(2) FPD-400D GENERAL CIRCUIT DIAGRAM

§1.(2) FPD-400D 綜合接線圖

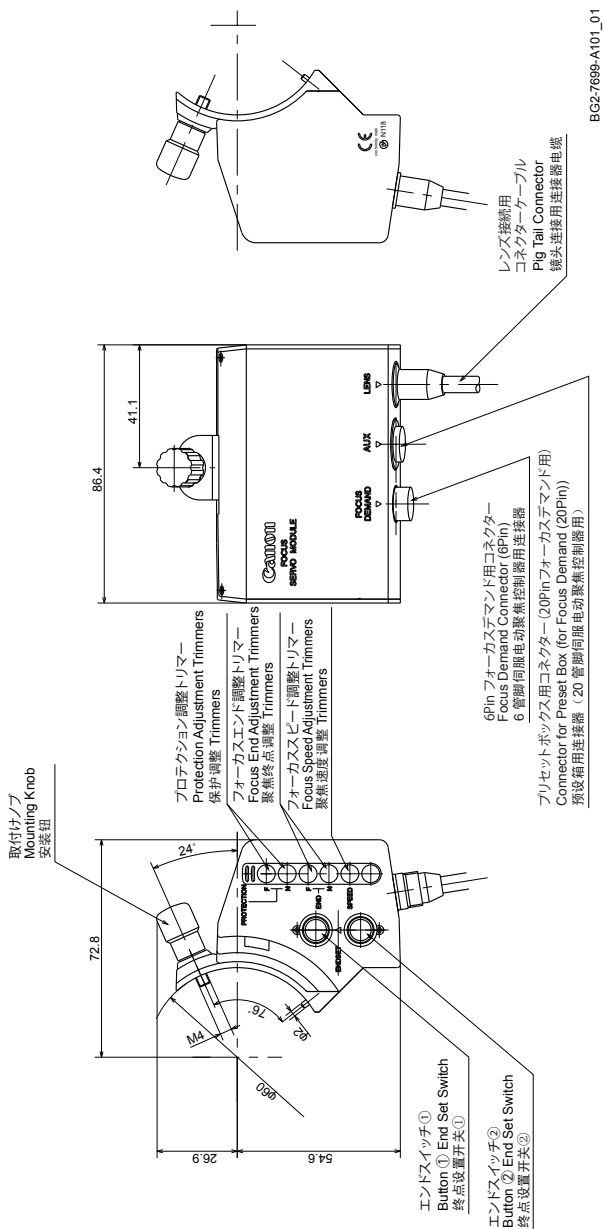

§2.(1) FPM-420D 外觀圖
 §2.(1) FPM-420D EXTERNAL VIEW
 §2.(1) FPM-420D 外观圖

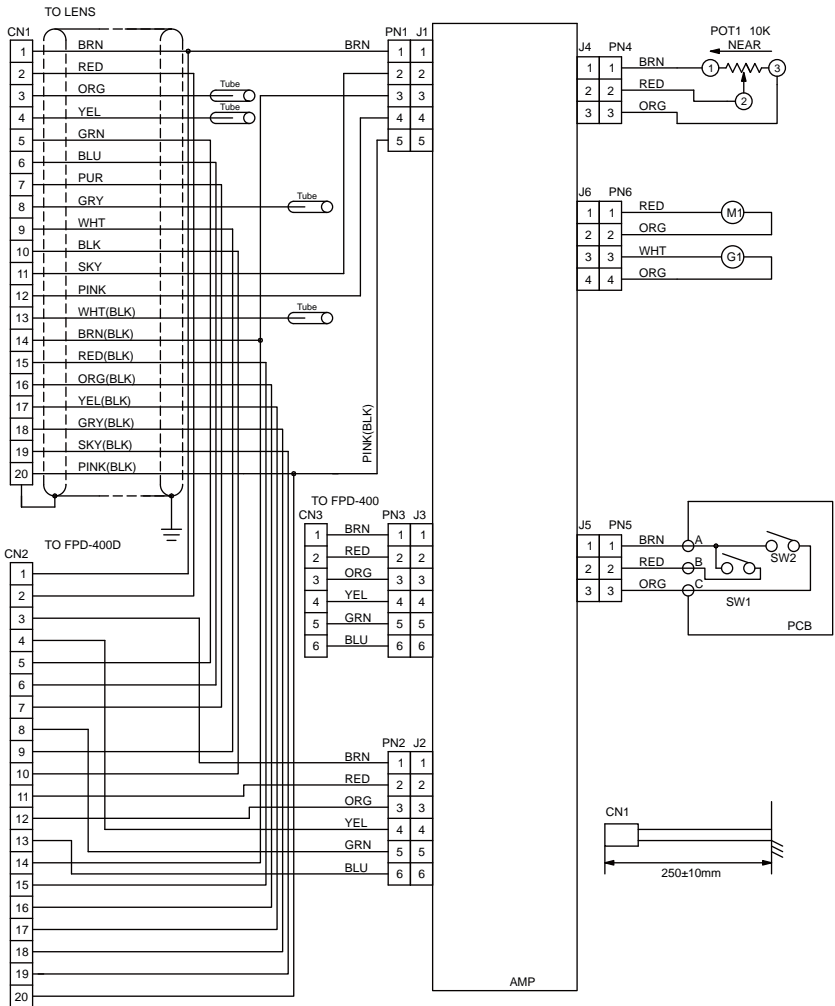

BG2-7699-A501_02

§2.(2) FPM-420D 総合結線図

§2.(2) FPM-420D GENERAL CIRCUIT DIAGRAM

§2.(2) FPM-420D 综合接线图

索引

"A" タイプ	13
"R" タイプ	10
エンドセットスイッチ	12
クランパー	10
初期調整	12
デジタル "A" タイプ	13
モードスイッチ	15
リバーススイッチ	15

INDEX

"A" TYPE	29
CLAMPER	26
DIGITAL "A" TYPE	29
END SET SWITCH	28
FOCUS CHARACTERISTICS CURVE SELECTION SWITCH	31
INITIAL ADJUSTMENT	28
REVERSE SWITCH	31
"R" TYPE	26

索引

"A" 型	45
初始調整	44
夹具	42
模式开关	47
"R" 型	42
数字 "A" 型	45
终点设置开关	44
转向开关	47



キヤノン株式会社

放送機器事業部

〒 321-3298

栃木県宇都宮市清原工業団地 23-10

Telephone: (028)667-5711

仕様・外觀・商品構成等はお断りなく変更することがあります。

CANON INC.

Broadcast Equipment Group

23-10, Kiyohara-kogyo-danchi, Utsunomiya-shi, Tochigi-ken, 321-3298, Japan

Telephone: +81(0)28-667-5711

Subject to change without notice.

佳能公司

放送机器事业部

〒 321-3298

栃木县宇都宫市清原工业团地 23-10

TEL +81(0)28-667-5711

规格・外觀・商品构成等进行变更，恕不事先一一通知。

修订日记

2010.08

原产地：日本

Pub No. B-IM-30092A

0810S10

© 2010.08 CANON INC

PRINTED IN JAPAN